

TIG INVERTER WELDER

Model 98233

SET UP AND OPERATING INSTRUCTIONS



Visit our website at: <http://www.harborfreight.com>



**Read this material before using this product.
Failure to do so can result in serious injury.
SAVE THIS MANUAL.**

Copyright© 2008 by Harbor Freight Tools®. All rights reserved. No portion of this manual or any artwork contained herein may be reproduced in any shape or form without the express written consent of Harbor Freight Tools. Diagrams within this manual may not be drawn proportionally. Due to continuing improvements, actual product may differ slightly from the product described herein. Tools required for assembly and service may not be included.

For technical questions or replacement parts, please call 1-800-444-3353.

Revised Manual 09j

| CONTENTS | | | |
|--|-----------|---|-----------|
| IMPORTANT SAFETY INFORMATION | 3 | GENERAL OPERATING INSTRUCTIONS | 13 |
| GENERAL POWER TOOL SAFETY WARNINGS..... | 3 | MAINTENANCE AND SERVICING | 15 |
| TIG WELDER SAFETY WARNINGS.. | 5 | CLEANING, MAINTENANCE, AND LUBRICATION | 15 |
| GROUNDING | 9 | TROUBLESHOOTING..... | 16 |
| GROUNDING TOOLS..... | 9 | MAIN UNIT PARTS LIST | 17 |
| EXTENSION CORDS | 9 | MAIN UNIT DIAGRAM..... | 17 |
| SYMBOLS..... | 10 | TORCH PARTS LIST | 18 |
| SPECIFICATIONS..... | 11 | TORCH PARTS DIAGRAM..... | 18 |
| UNPACKING | 11 | ELECTRICAL DIAGRAM..... | 19 |
| LIST OF CONTENTS..... | 11 | LIMITED 1 YEAR / 90 DAY WARRANTY | 20 |
| OPERATING INSTRUCTIONS | 11 | | |
| TOOL SET UP | 11 | | |
| WORK PIECE AND WORK AREA SET UP | 11 | | |

SAVE THIS MANUAL

Keep this manual for the safety warnings and precautions, assembly, operating, inspection, maintenance and cleaning procedures. Write the product's serial number in the back of the manual near the assembly diagram (or month and year of purchase if product has no number). Keep this manual and the receipt in a safe and dry place for future reference.

IMPORTANT SAFETY INFORMATION

In this manual, on the labeling, and all other information provided with this product:



This is the safety alert symbol. It is used to alert you to potential personal injury hazards. Obey all safety messages that follow this symbol to avoid possible injury or death.

DANGER

DANGER indicates a hazardous situation which, if not avoided, will result in death or serious injury.

WARNING

WARNING indicates a hazardous situation which, if not avoided, could result in death or serious injury.

CAUTION

CAUTION, used with the safety alert symbol, indicates a hazardous situation which, if not avoided, could result in minor or moderate injury.

NOTICE

NOTICE is used to address practices not related to personal injury.

CAUTION

CAUTION, without the safety alert symbol, is used to address practices not related to personal injury.

General Power Tool Safety Warnings



WARNING Read all safety warnings and instructions. Failure to follow the warnings and instructions may result in electric shock, fire and/or serious injury. Save all warnings and instructions for future reference. The term "power tool" in the warnings refers to your mains-operated (corded) power tool.

1. **Work area safety**
 - a. **Keep work area clean and well lit.** Cluttered or dark areas invite accidents.
 - b. **Do not operate power tools in explosive atmospheres, such as in the presence of flammable liquids, gases or dust.** Power tools create sparks which may ignite the dust or fumes.
 - c. **Keep children and bystanders away while operating a power tool.** Distractions can cause you to lose control.
2. **Electrical safety**
 - a. **Power tool plugs must match the outlet. Never modify the plug in any way. Do not use any adapter plugs with grounded power tools.**

Unmodified plugs and matching outlets will reduce risk of electric shock.

- b. **Avoid body contact with grounded surfaces such as pipes, radiators, ranges and refrigerators.** *There is an increased risk of electric shock if your body is grounded.*
 - c. **Do not expose power tools to rain or wet conditions.** *Water entering a power tool will increase the risk of electric shock.*
 - d. **Do not abuse the cord. Never use the cord for carrying, pulling or unplugging the power tool. Keep cord away from heat, oil, sharp edges or moving parts.** *Damaged or entangled cords increase the risk of electric shock.*
 - e. **When operating a power tool outdoors, use an extension cord suitable for outdoor use.** *Use of a cord suitable for outdoor use reduces the risk of electric shock.*
 - f. **If operating a power tool in a damp location is unavoidable, use a Ground Fault Circuit Interrupter (GFCI) protected supply.** *Use of a GFCI reduces the risk of electric shock.*
3. **Personal safety**
- a. **Stay alert, watch what you are doing and use common sense when operating a power tool. Do not use a power tool while you are tired or under the influence of drugs, alcohol or medication.** *A moment of inattention while operating power tools may result in serious personal injury.*
 - b. **Use safety equipment.** *Always wear ANSI-approved safety glasses and arc shaded, impact safety full face shield. Safety equipment such as NIOSH-approved respirator, heavy-duty work gloves, non-skid safety shoes, or hearing protection used for appropriate conditions will reduce personal injuries.*
- c. **Prevent unintentional starting.** **Ensure the switch is in the off-position before connecting to power source or moving the tool.** *Carrying power tools with your finger on the switch or energizing power tools that have the switch on invites accidents.*
 - d. **Remove any adjusting key or wrench before turning the power tool on.** *A wrench or a key left attached to a rotating part of the power tool may result in personal injury.*
 - e. **Do not overreach. Keep proper footing and balance at all times.** *This enables better control of the power tool in unexpected situations.*
 - f. **Dress properly. Do not wear loose clothing or jewelry. Keep your hair, clothing and gloves away from moving parts.** *Loose clothes, jewelry or long hair can be caught in moving parts.*
 - g. **If devices are provided for the connection of dust extraction and collection facilities, ensure these are connected and properly used.** *Use of these devices can reduce dust-related hazards.*
 - h. **Only use safety equipment that has been approved by an appropriate standards agency.** *Unapproved safety equipment may not provide adequate protection. Eye protection must be ANSI-approved and breathing protection must be NIOSH-ap-*

proved for the specific hazards in the work area.

4. **Power tool use and care**

- a. **Do not force the power tool. Use the correct power tool for your application.** *The correct power tool will do the job better and safer at the rate for which it was designed.*
- b. **Do not use the power tool if the switch does not turn it on and off.** *Any power tool that cannot be controlled with the switch is dangerous and must be repaired.*
- c. **Disconnect the plug from the power source from the power tool before making any adjustments, changing accessories, or storing power tools.** *Such preventive safety measures reduce the risk of starting the power tool accidentally.*
- d. **Store idle power tools out of the reach of children and do not allow persons unfamiliar with the power tool or these instructions to operate the power tool.** *Power tools are dangerous in the hands of untrained users.*
- e. **Maintain power tools. Check for misalignment or binding of moving parts, breakage of parts and any other condition that may affect the power tool's operation. If damaged, have the power tool repaired before use.** *Many accidents are caused by poorly maintained power tools.*
- f. **Keep cutting tools sharp and clean.** *Properly maintained cutting tools with sharp cutting edges are less likely to bind and are easier to control.*



- g. **Use the power tool, accessories and tool bits etc. in accordance with these instructions, taking into account the working conditions and the work to be performed.** *Use of the power tool for operations different from those intended could result in a hazardous situation.*

5. **Service**

- a. **Have your power tool serviced by a qualified repair person using only identical replacement parts.** *This will ensure that the safety of the power tool is maintained.*



TIG Welder Safety Warnings

- 1. **Connection of a plug to this unit must only be performed by a certified electrician.**
- 2. Do not exceed 20 PSI for shielding gas; 10 PSI is recommended.
- 3. Avoid electrical shock. Do not permit electrically live parts, cables, or electrodes to contact skin, clothing, or gloves. Wear ANSI-approved protective clothing. This unit draws enough current to cause serious injury or death. Before turning the welder on, check the electrode holder to be sure that there are no protruding screws, and that all insulation is secure. Do not weld unless you are insulated from ground and the work piece.
- 4. Avoid eye and body damage. Arc rays and infrared radiation can injure eyes and burn skin. Wear ANSI approved eye and body protection. Do not allow viewing by visitors without proper eye and body protection. Use a Face Shield with arc shaded filter plate.

5. Move flammable and explosive material at least 35 feet from the welding arc to prevent welding sparks or molten metal from starting a fire. Keep a type ABC fire extinguisher within easy reach. Thoroughly clean the object being welded of any paint, grease, or other foreign material.
6. If working on a wall or ceiling prevent ignition of combustibles on the other side by moving them to a safe location.
7. Industrial applications must follow OSHA guidelines.
8.  Prevent eye injury and burns. Wearing and using ANSI-approved personal safety clothing and safety devices reduce the risk for injury.
9. Leather leggings, fire resistant shoes or boots should be worn when using this product. Do not wear pants with cuffs, shirts with open pockets, or any clothing that can catch and hold molten metal or sparks.
10. Keep clothing and work surfaces free of grease, oil, solvents, or any flammable substances. Wear dry, insulating gloves and protective clothing.
11. Wear an approved head covering to protect the head and neck. Use aprons, cape, sleeves, shoulder covers, and bibs designed and approved for welding and cutting procedures.
12. When welding/cutting overhead or in confined spaces, wear flame resistant ear plugs or ear muffs to keep sparks out of ears.
13.  Prevent accidental fires. Remove any combustible material from the work area.
14. When possible, move the work to a location well away from combustible materials. If relocation is not possible, protect the combustibles with a cover made of fire resistant material.
15. Do not use near degreasing or painting operations.
16. Enclose the work area with portable fire resistant screens. Protect combustible walls, ceilings, floors, etc., from sparks and heat with fire resistant covers.
17. Do not weld or cut on materials having a combustible coating or combustible internal structure, as in walls or ceilings, without an approved method for eliminating the hazard.
18. After spot welding, make a thorough examination for evidence of fire. Be aware that easily-visible smoke or flame may not be present for some time after the fire has started. Provide adequate ventilation in work areas to prevent accumulation of flammable gases, vapors, and dust. Do not apply heat to a container that has held an unknown substance or a combustible material whose contents, when heated, can produce flammable or explosive vapors. Clean and purge containers before applying heat. Vent closed containers, including castings, before preheating, welding, or cutting.
19. Do not touch live electrical parts. Wear dry, insulating gloves. Do not touch electrode or conductor tong

with bare hand. Do not wear wet or damaged gloves.

20. Ensure that the unit is placed on a stable location before use. If this unit falls while plugged in, severe injury, electric shock, or fire may result.

| ⚠ WARNING | |
|---|---|
|  |  |
| INHALATION HAZARD: Welding and Plasma Cutting Produce TOXIC FUMES. | |
| Exposure to welding or cutting exhaust fumes can increase the risk of developing certain cancers, such as cancer of the larynx and lung cancer. Also, some diseases that may be linked to exposure to welding or plasma cutting exhaust fumes are: | |
| <ul style="list-style-type: none">• Early onset of Parkinson's Disease• Heart disease• Damage to the reproductive organs• Inflammation of the small intestine or stomach• Respiratory diseases such as emphysema, bronchitis, or pneumonia• Ulcers• Kidney damage | |
| Use natural or forced air ventilation and wear a respirator approved by NIOSH to protect against the fumes produced to reduce the risk of developing the above illnesses. | |

21. Avoid overexposure to fumes and gases. Always keep your head out of the fumes. Do not breathe the fumes. Use enough ventilation or exhaust, or both, to keep fumes and gases from your breathing zone and general area.

22. Where ventilation is questionable, have a qualified technician take an air sampling to determine the need for corrective measures. Use mechanical ventilation to improve air quality. If engineering controls are not feasible, use an approved respirator.

23. Follow OSHA guidelines for Permissible Exposure Limits (PEL's) for various fumes and gases.

24. Follow the American Conference of Governmental Industrial Hygienists recommendations for Threshold Limit Values (TLV's) for fumes and gases.

25. Have a recognized specialist in Industrial Hygiene or Environmental Services check the operation and air quality and make recommendations for the specific welding or cutting situation.

26. Maintain labels and nameplates on the tool. These carry important safety information. If unreadable or missing, contact Harbor Freight Tools for a replacement.

27. Avoid unintentional starting. Prepare to begin work before turning on the tool.

28. Do not leave the tool unattended when it is plugged into an electrical outlet. Turn off the tool, and unplug it from its electrical outlet before leaving.

29. Do not splice welding cables.

30. Do not weld sealed containers. All containers should be considered unsafe unless they have been rendered safe or declared safe by a qualified person.

31. This product is not a toy. Keep it out of reach of children.
32. People with pacemakers should consult their physician(s) before use. Electromagnetic fields in close proximity to heart pacemaker could cause pacemaker interference or pacemaker failure. In addition, people with pacemakers should:
 - Avoid operating alone.
 - Do not use with power switch locked on.
 - Properly maintain and inspect to avoid electrical shock.
 - Any power cord must be properly grounded. Ground Fault Circuit Interrupter (GFCI) should also be implemented – it prevents sustained electrical shock.
33. A GFCI may provide protection from the “wall to the welder”, but a GFCI will not protect you from faults between the “welder and the work”. Because a GFCI cannot protect you from faults between the “welder and the work” using proper welding technique and personal protection equipment while welding is crucial. Ground the workpiece as well as the welder.
34. Use a non-conductive safety mat on the work surface to insulate the operator from the work surface.
35. Turn off, unplug, and discharge electrodes after use and before service.
36. Do not attempt to cool the welding tip with fluids. Allow the tip to cool down gradually.
37. Secure cylinders upright to prevent them from falling. All cylinders should be used and stored in an upright position. Never drop or strike a cylinder. Do not use cylinders that have been dented. Cylinder caps should be used when moving or storing cylinders. Empty cylinders should be kept in specified areas and clearly marked “empty.”
38. Some dust created by power sanding, sawing, grinding, drilling, and other construction activities, contains chemicals known [to the State of California] to cause cancer, birth defects or other reproductive harm. Some examples of these chemicals are:
 - Lead from lead-based paints
 - Crystalline silica from bricks and cement or other masonry products
 - Arsenic and chromium from chemically treated lumber
 Your risk from these exposures varies, depending on how often you do this type of work. To reduce your exposure to these chemicals: work in a well ventilated area, and work with approved safety equipment, such as those dust masks that are specially designed to filter out microscopic particles. (California Health & Safety Code § 25249.5, *et seq.*)
39. WARNING: Handling the cord on this product will expose you to lead, a chemical known to the State of California to cause cancer, and birth defects or other reproductive harm. Wash hands after handling. (California Health & Safety Code § 25249.5, *et seq.*)
40. The warnings, precautions, and instructions discussed in this instruction manual cannot cover all possible conditions and situations that may occur. It must be understood by the operator that common sense and caution are

factors which cannot be built into this product, but must be supplied by the operator.



SAVE THESE INSTRUCTIONS.

GROUNDING



WARNING TO PREVENT ELECTRIC SHOCK



AND DEATH FROM INCORRECT GROUNDING WIRE CONNECTION:

Check with a qualified electrician if you are in doubt as to whether the outlet is properly grounded. Have a plug installed by a certified electrician. Do not use the tool if the power cord or plug is damaged. If damaged, have it repaired by a service facility before use. If the plug will not fit the outlet, have a proper outlet installed by a qualified electrician.

Grounded Tools

1. The grounding prong in the plug is connected through the green wire inside the cord to the grounding system in the tool. The green wire in the cord must be the only wire connected to the tool's grounding system and must never be attached to an electrically "live" terminal.
2. The tool must be plugged into an appropriate outlet, properly installed and grounded in accordance with all codes and ordinances.







Extension Cords

1. As the distance from the supply outlet increases, you must use a heavier gauge extension cord. Using extension cords with inadequately sized wire causes a serious drop in voltage, resulting in loss of power and possible tool damage. **(See Table A.)**
2. The smaller the gauge number of the wire, the greater the capacity of the cord. For example, a 14 gauge cord can carry a higher current than a 16 gauge cord. **(See Table A.)**
3. When using more than one extension cord to make up the total length, make sure each cord contains at least the minimum wire size required. **(See Table A.)**
4. If you are using one extension cord for more than one tool, add the nameplate amperes and use the sum to determine the required minimum cord size. **(See Table A.)**
5. If you are using an extension cord outdoors, make sure it is marked with the suffix "W-A" ("W" in Canada) to indicate it is acceptable for outdoor use.
6. Make sure the extension cord is properly wired and in good electrical condition. Always replace a damaged extension cord or have it repaired by a qualified electrician before using it.
7. Protect the extension cords from sharp objects, excessive heat, and damp or wet areas.

| RECOMMENDED MINIMUM WIRE GAUGE FOR EXTENSION CORDS* (120/240 VOLT) | | | | | |
|---|-----------------------|-----|-----|------|------|
| NAMEPLATE AMPERES (at full load) | EXTENSION CORD LENGTH | | | | |
| | 25' | 50' | 75' | 100' | 150' |
| 0 – 2.0 | 18 | 18 | 18 | 18 | 16 |
| 2.1 – 3.4 | 18 | 18 | 18 | 16 | 14 |
| 3.5 – 5.0 | 18 | 18 | 16 | 14 | 12 |
| 5.1 – 7.0 | 18 | 16 | 14 | 12 | 12 |
| 7.1 – 12.0 | 18 | 14 | 12 | 10 | - |
| 12.1 – 16.0 | 14 | 12 | 10 | - | - |
| 16.1 – 20.0 | 12 | 10 | - | - | - |

TABLE A * Based on limiting the line voltage drop to five volts at 150% of the rated amperes.

Symbology

| | |
|---|--------------------------------------|
|  | Double Insulated |
|  | Canadian Standards Association |
|  | Underwriters Laboratories, Inc. |
|  | Volts Alternating Current |
|  | Amperes |
|  | No Load Revolutions per Minute (RPM) |

SPECIFICATIONS

| | |
|-------------------------|--|
| Electrical Requirements | 230 V~ / 60 Hz 19.8 Amp |
| Welding Current Range | 10 to 165 A |
| Duty Cycle | 60% @ 165 Amps 80% @ 126 Amps 100% @ 98 Amps |
| Gas Fittings | Intake: 9/16" 18 TPI Outlet: 3/8" 24 TPI |
| Gas Input | 10 PSI |
| Tungsten Electrode Size | 5/32" |
| Capacity | up to 1/4" Steel Plate |

UNPACKING

When unpacking, check to make sure that the item is intact and undamaged. If any parts are missing or broken, please call Harbor Freight Tools at the number shown on the cover of this manual as soon as possible.

List of contents

| Description | Qty |
|-------------------------|-----|
| Electrode Holder | 1 |
| TIG Torch | 1 |
| Ceramic Gas Nozzle | 4 |
| 1/8" Copper Collet Body | 1 |
| Copper Collet | 4 |
| Black Cap | 1 |
| Ground Clamp | 1 |

SET UP INSTRUCTIONS



Read the **ENTIRE IMPORTANT SAFETY INFORMATION** section at the beginning of this manual including all text under subheadings therein before set up or use of this product.

Tool Set Up

⚠ WARNING TO PREVENT SERIOUS INJURY FROM ACCIDENTAL OPERATION:
Turn the Power Switch of the tool to its "OFF" position and unplug the tool from its electrical outlet before performing any inspection, maintenance, or cleaning procedures.

Connection of a 230V UL listed plug rated to at least 20 Amps to this unit must only be performed by a certified electrician. The plug installed for the Welder must match the receptacle.

Work Piece and Work Area Set Up

1. Designate a work area that is clean and well-lit. The work area must not allow access by children or pets to prevent injury and distraction.
2. Route the power cord along a safe route to reach the work area without creating a tripping hazard or exposing the power cord to possible damage. The power cord must reach the work area with enough extra length to allow free movement while working.
3. Secure loose work pieces using a vise or clamps (not included) to prevent movement while working. For greater safety; ground the workpiece.
4. There must not be hazardous objects, such as utility lines or foreign objects, nearby that will present a hazard while working.

Front of Welder



Back of Welder



Proper TIG Connection



Proper Arc (stick) Welding Connection



OPERATING INSTRUCTIONS

⚠ WARNING Wear protective gear during use; ANSI-approved, shade number level 14 eye protection, a full face shield (or welding mask), ear protection, welding gloves and apron, NIOSH-approved respirator, and fire resistant work clothes without pockets should be worn when welding. Light from the arc can cause permanent damage to the eyes and skin. Do not breathe arc fumes.

1. Place the Welder on a level surface that can bear its weight near the work area.
2. Connect a 12 AWG ground wire (not included) to the Ground Post on the rear of the Welder (see page 12) and route it to ground. If possible, ground the workpiece independent of the welder.
2. Plug the cable of the Grounding Clamp (34) into the welder and secure the clamp to a clean, exposed metal part of the workpiece.
3. Assemble the desired accessories and rod inside the tip of the TIG Torch handle.
 - a. Unscrew the Ceramic Nozzle (6A) on the Torch Handle (4A).
 - b. Unscrew the Collet Housing (5A).
 - c. Place a 5/32" prepared tungsten welding rod (not included) into the torch.
 - d. Screw the Collet Housing and Ceramic Nozzle back onto the Torch.
4. Connect a hose and coupling from the gas regulator on an Argon gas tank (none included) to the Argon Gas Inlet on the back of the unit. Follow the gas cylinder manufacturer's instructions for set-up and use.
5. The Gas Flow Delay Switch allows control of how long the shielding gas flows. To conserve shielding gas switch it to "short". If the welded surface is being tarnished, change the switch to "long".

TIG Connection

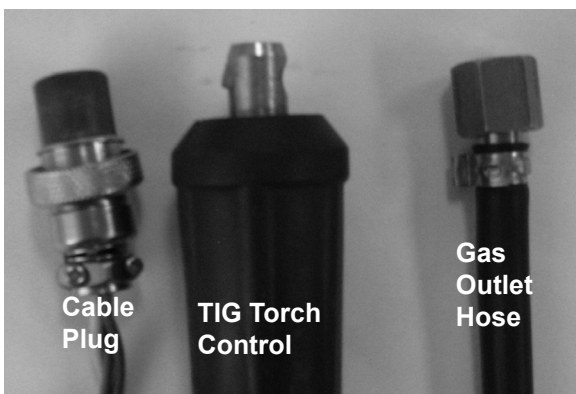

1. Connect the TIG torch control, cable plug, and gas outlet hose as shown on page 12. Twist to lock in place.

TIG Welding

6. Turn the Current Adjustment Knob to meet the needs of the job.
7. Move the Stick or TIG Switch to "TIG" (bottom position).
8. Plug the power cord into a grounded 230V electric socket and turn the Welder on.

⚠ DANGER! To prevent serious injury and death: The TIG Welder will immediately turn on when the

trigger is held down. When the operator is not holding the Torch, it must be sitting on a nonconductive, nonflammable surface.

9. Hold the Trigger down and tilt the torch forward. Keep a constant distance between the torch and the workpiece but do not contact it.

⚠ DANGER! To prevent serious injury and death: Feed the filler metal being used into the arc with a properly insulated holder (not included).

10. If too much current is drawn from the welder; the Thermal Overload protector will activate, the Overload indicator will light, and the welder will turn off until it cools down. It will automatically reset.

Arc (stick) Connection

1. Connect the Electrode Clamp and Cable (33) to the Arc Welder, as shown on page 12 and twist to lock in place.
2. Plug the cable of the Grounding Clamp (34) into the welder and secure the clamp to a clean, exposed metal part of the workpiece.
3. Place the metal portion of the welding rod inside the jaws of the Electrode Clamp. Welding rod types vary for welding different metals.

Arc Welding

4. Move the Stick or TIG Switch to "Arc" (top position).
5. Turn the Current Adjustment Knob to meet the needs of the job.

6. Plug the power cord into a grounded 230V electric socket and turn the Welder on.

⚠ DANGER! To prevent serious injury and death: If the operator is not holding the Torch, it must be sitting on a nonconductive, nonflammable surface. The Stick Welder will immediately turn on when the power button is turned on.

7. Stroke the workpiece lightly to ignite the arc. Do not strike like a match. Never tap the electrode wire to ignite the arc; it will damage the electrode.
8. When the arc ignites, tilt the electrode forward and hold it near the workpiece.
9. If too much current is drawn from the welder; the Thermal Overload protector will activate, the Overload indicator will light, and the welder will turn off until it cools down. It will automatically reset.
10. When finished welding; lift the electrode from the workpiece, discharge the electrode to ground and turn the Welder off.
11. Place the handle down on a nonflammable, nonconductive surface.
12. To prevent accidents disconnect the tool from its power supply after use. Allow the tool to cool down, clean, then store the tool indoors out of children's reach.

MAINTENANCE AND SERVICING



Procedures not specifically explained in this manual must be performed only by a qualified technician.

⚠️ WARNING

TO PREVENT SERIOUS INJURY

FROM ACCIDENTAL OPERATION:

Turn the Power Switch of the tool to its “OFF” position and unplug the tool from its electrical outlet before performing any inspection, maintenance, or cleaning procedures.

TO PREVENT SERIOUS INJURY FROM TOOL FAILURE:

Do not use damaged equipment. If abnormal noise or vibration occurs, have the problem corrected before further use.

Cleaning, Maintenance, and Lubrication

- BEFORE EACH USE**, inspect the general condition of the tool. Check for loose screws, misalignment or binding of moving parts, cracked or broken parts, damaged electrical wiring, and any other condition that may affect its safe operation.
- AFTER USE**, clean external surfaces of the tool with clean cloth.
- Periodically clear out the cooling vent and fan with compressed air.
- The Ceramic Nozzle (6A)** will occasionally need to be cleaned of spatter from welding. Clean it with a metal brush. When the nozzle deteriorates or can no longer be cleaned, it will need to be replaced. Unscrew the nozzle and replace it with a new one.
- ⚠️ WARNING!** If the supply cord of this power tool is damaged, it must be replaced only by a qualified service technician.

PLEASE READ THE FOLLOWING CAREFULLY

THE MANUFACTURER AND/OR DISTRIBUTOR HAS PROVIDED THE PARTS LIST AND ASSEMBLY DIAGRAM IN THIS MANUAL AS A REFERENCE TOOL ONLY. NEITHER THE MANUFACTURER OR DISTRIBUTOR MAKES ANY REPRESENTATION OR WARRANTY OF ANY KIND TO THE BUYER THAT HE OR SHE IS QUALIFIED TO MAKE ANY REPAIRS TO THE PRODUCT, OR THAT HE OR SHE IS QUALIFIED TO REPLACE ANY PARTS OF THE PRODUCT. IN FACT, THE MANUFACTURER AND/OR DISTRIBUTOR EXPRESSLY STATES THAT ALL REPAIRS AND PARTS REPLACEMENTS SHOULD BE UNDERTAKEN BY CERTIFIED AND LICENSED TECHNICIANS, AND NOT BY THE BUYER. THE BUYER ASSUMES ALL RISK AND LIABILITY ARISING OUT OF HIS OR HER REPAIRS TO THE ORIGINAL PRODUCT OR REPLACEMENT PARTS THERETO, OR ARISING OUT OF HIS OR HER INSTALLATION OF REPLACEMENT PARTS THERETO.

Troubleshooting

| Problem | Possible Causes | Likely Solutions |
|---|--|--|
| Tool will not start | <ol style="list-style-type: none"> 1. No power at outlet. 2. Cord not connected. 3. Line voltage incorrect. | <ol style="list-style-type: none"> 1. Check power at outlet. 2. Check that cord is plugged in. 3. Make sure the welder is plugged into a 230V electrical outlet. |
| No weld output with ready light on | <ol style="list-style-type: none"> 1. Weld cable loose. 2. Bad work clamp to workpiece connection. | <ol style="list-style-type: none"> 1. Tighten weld cable connection at welder. 2. Make sure the area where the clamp is attached is clean, exposed metal; free of dirt, paint and oil. |
| No weld output; high temperature light on | <ol style="list-style-type: none"> 1. Welder overheated. 2. Duty cycle or amps too high. 3. Airflow is blocked. | <ol style="list-style-type: none"> 1. Allow unit to cool with the fan on. 2. Reduce duty cycle or amps. 3. Clean vents and fan out with compressed air. |
| Erratic or improper arc or welding output | <ol style="list-style-type: none"> 1. Bad weld connections. 2. Polarity incorrect. 3. Workpiece painted or dirty. 4. Ceramic Nozzle obstructed by welding spatter. | <ol style="list-style-type: none"> 1. Clean and tighten weld connections. 2. Connect polarity correctly. 3. Clean workpiece thoroughly. 4. Clean or replace nozzle. |
| Fan not operating | <ol style="list-style-type: none"> 1. Fan blocked/dirty. 2. Fan broken. | <ol style="list-style-type: none"> 1. Remove obstruction and clean with compressed air. 2. Have the fan replaced by a qualified service technician. |
| Main Supply Fuse shuts off frequently | Circuit Breaker rating is too low. | Install a circuit breaker rated for greater than 20 Amps. |



Follow all safety precautions whenever diagnosing or servicing the tool. Disconnect power supply before service.

MAIN UNIT PARTS LIST

| Part | Description | Qty |
|------|---------------|-----|
| 1 | Handle | 1 |
| 2 | Cover | 1 |
| 3 | Back Cover | 1 |
| 4 | Divider | 1 |
| 5 | PCB | 1 |
| 6 | Transformer | 1 |
| 7 | Drive PCB | 1 |
| 8 | Control PCB | 1 |
| 9 | Display | 1 |
| 10 | Light | 1 |
| 11 | Light | 1 |
| 12 | Toggle Switch | 1 |
| 13 | Toggle Switch | 1 |
| 14 | Socket | 1 |
| 15 | Gas Inlet | 1 |
| 16 | Socket | 1 |
| 17 | Coupling Coil | 1 |
| 18 | Transformer | 1 |

MAIN UNIT PARTS LIST

| Part | Description | Qty |
|------|---------------------------------------|-----|
| 19 | Reactance | 1 |
| 20 | Resister | 1 |
| 21 | Inductor | 1 |
| 22 | Radiator | 1 |
| 23 | Inductor | 1 |
| 24 | Rectifier | 1 |
| 25 | Fan | 1 |
| 26 | Fan Guard | 1 |
| 27 | Inverter PCB | 1 |
| 28 | Electromagnet | 1 |
| 29 | High Pressure PCB | 1 |
| 30 | Splitter | 1 |
| 31 | Torch Switch Mounting | 1 |
| 32 | TIG Torch and Cable (not shown) | 1 |
| 33 | Electrode Clamp and Cable (not shown) | 1 |
| 34 | Ground Clamp and Cable (not shown) | 1 |

MAIN UNIT DIAGRAM

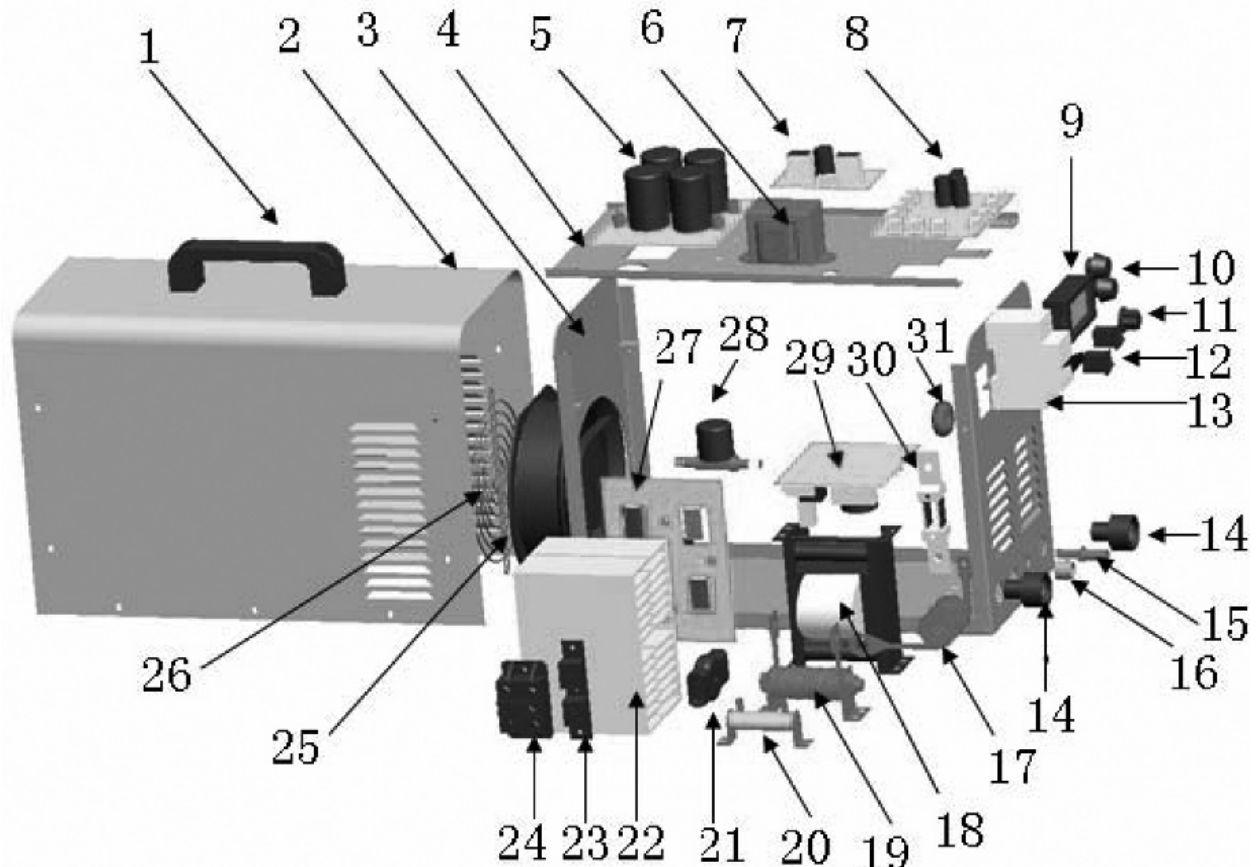

TORCH PARTS LIST

| Part | Description | Qty |
|------|----------------------|-----|
| 1A | Long Back Cap | 1 |
| 2A | Short Back Cap | 1 |
| 3A1 | Collet 1/16" (1.6mm) | 1 |
| 3A2 | Collet 2/25" (2.0mm) | 1 |
| 3A3 | Collet 3/32" (2.4mm) | 1 |
| 3A4 | Collet 1/8" (3.2mm) | 1 |

TORCH PARTS LIST

| Part | Description | Qty |
|------|------------------------------|-----|
| 4A | Torch Handle | 1 |
| 5A | Collet Housing | 1 |
| 6A1 | Ceramic Nozzle size 4; 10N50 | 1 |
| 6A2 | Ceramic Nozzle size 5; 10N49 | 1 |
| 6A3 | Ceramic Nozzle size 6; 10N48 | 1 |
| 6A4 | Ceramic Nozzle size 7; 10N47 | 1 |

TORCH PARTS DIAGRAM

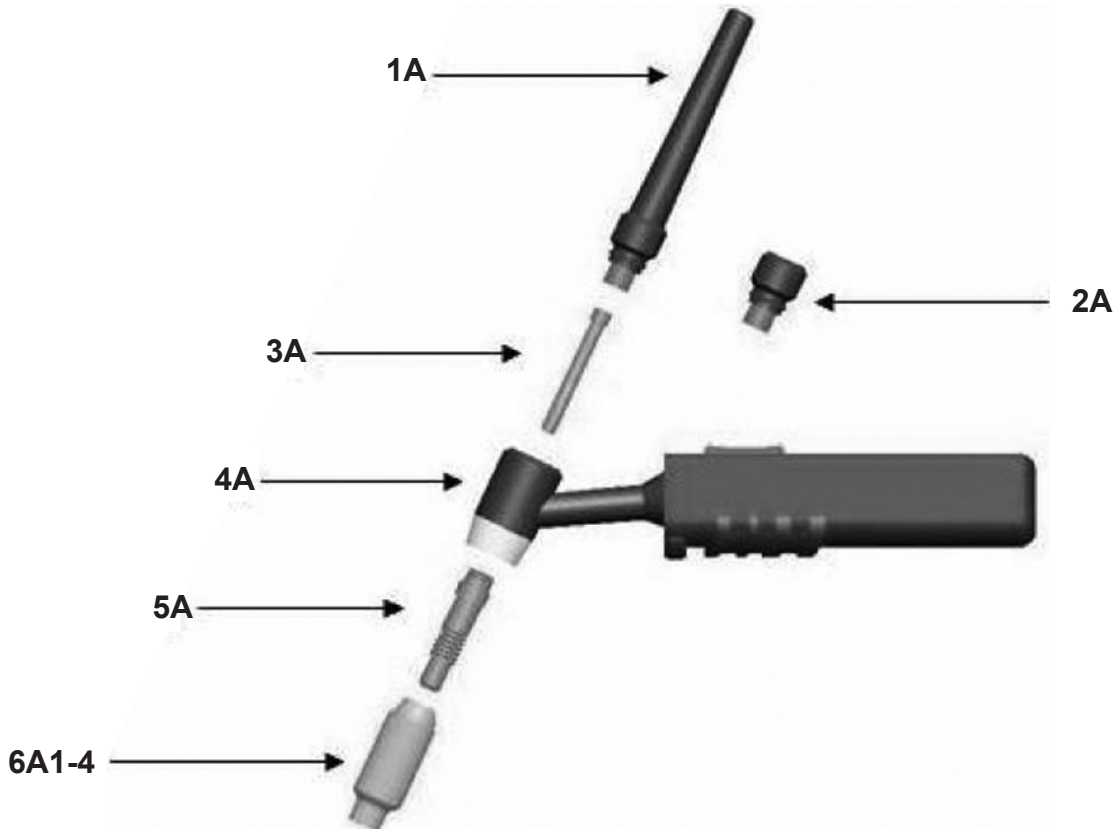

Record Product's Serial Number Here: _____

Note: If product has no serial number, record month and year of purchase instead.

Note: Some parts are listed and shown for illustration purposes only, and are not available individually as replacement parts.

ELECTRICAL DIAGRAM

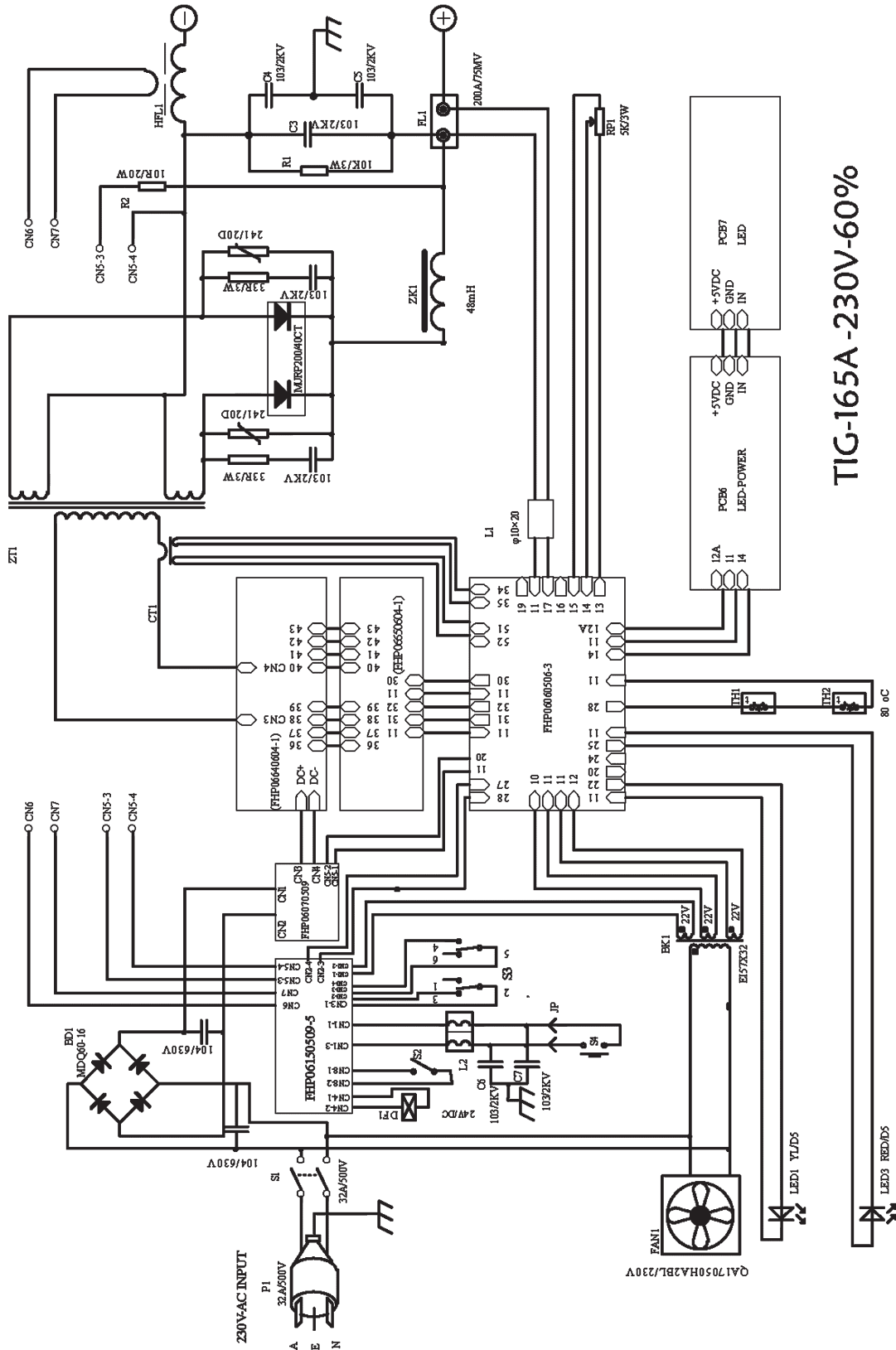

LIMITED 1 YEAR / 90 DAY WARRANTY

Harbor Freight Tools Co. makes every effort to assure that its products meet high quality and durability standards, and warrants to the original purchaser that for a period of ninety days from date of purchase that the torch, liner, wire feed mechanism (if applicable), welding clamps, electrode holders, cables and accessories packed with the welder are free of defects in materials and workmanship. **This Limited 90 Day/1 Year Warranty shall not apply to consumable parts such as tips, welding wire, and gas nozzles.** Harbor Freight Tools also warrants to the original purchaser, for a period of one year from date of purchase, that the transformer and rectifier are free from defects in materials and workmanship (90 days if used by a professional contractor or if used as rental equipment). This warranty does not apply to damage due directly or indirectly to misuse, abuse, negligence or accidents, repairs or alterations outside our facilities, normal wear and tear, or to lack of maintenance. We shall in no event be liable for death, injuries to persons or property, or for incidental, contingent, special or consequential damages arising from the use of our product. Some states do not allow the exclusion or limitation of incidental or consequential damages, so the above limitation of exclusion may not apply to you. THIS WARRANTY IS EXPRESSLY IN LIEU OF ALL OTHER WARRANTIES, EXPRESS OR IMPLIED, INCLUDING THE WARRANTIES OF MERCHANTABILITY AND FITNESS.

To take advantage of this warranty, the product or part must be returned to us with transportation charges prepaid. Proof of purchase date and an explanation of the complaint must accompany the merchandise. If our inspection verifies the defect, we will either repair or replace the product at our election or we may elect to refund the purchase price if we cannot readily and quickly provide you with a replacement. We will return repaired products at our expense, but if we determine there is no defect, or that the defect resulted from causes not within the scope of our warranty, then you must bear the cost of returning the product.

This warranty gives you specific legal rights and you may also have other rights which vary from state to state.

3491 Mission Oaks Blvd. • PO Box 6009 • Camarillo, CA 93011 • (800) 444-3353

Free Manuals Download Website

<http://myh66.com>

<http://usermanuals.us>

<http://www.somanuals.com>

<http://www.4manuals.cc>

<http://www.manual-lib.com>

<http://www.404manual.com>

<http://www.luxmanual.com>

<http://aubethermostatmanual.com>

Golf course search by state

<http://golfingnear.com>

Email search by domain

<http://emailbydomain.com>

Auto manuals search

<http://auto.somanuals.com>

TV manuals search

<http://tv.somanuals.com>