



10" HEAVY-DUTY 15 AMP TABLE SAW

Model 66630

SET UP AND OPERATING INSTRUCTIONS



Distributed exclusively by Harbor Freight Tools®.

3491 Mission Oaks Blvd., Camarillo, CA 93011

Visit our website at: <http://www.harborfreight.com>



**Read this material before using this product.
Failure to do so can result in serious injury.
SAVE THIS MANUAL.**

Copyright© 2008 by Harbor Freight Tools®. All rights reserved. No portion of this manual or any artwork contained herein may be reproduced in any shape or form without the express written consent of Harbor Freight Tools. Diagrams within this manual may not be drawn proportionally. Due to continuing improvements, actual product may differ slightly from the product described herein. Tools required for assembly and service may not be included.

For technical questions or replacement parts, please call 1-800-444-3353.

SAVE THIS MANUAL

Keep this manual for the safety warnings and precautions, assembly, operating, inspection, maintenance and cleaning procedures. Write the product's serial number in the back of the manual near the assembly diagram (or month and year of purchase if product has no number). Keep this manual and the receipt in a safe and dry place for future reference.

IMPORTANT SAFETY INFORMATION

In this manual, on the labeling, and all other information provided with this product:



This is the safety alert symbol. It is used to alert you to potential personal injury hazards. Obey all safety messages that follow this symbol to avoid possible injury or death.

DANGER

DANGER indicates a hazardous situation which, if not avoided, will result in death or serious injury.

WARNING

WARNING indicates a hazardous situation which, if not avoided, could result in death or serious injury.

CAUTION

CAUTION, used with the safety alert symbol, indicates a hazardous situation which, if not avoided, could result in minor or moderate injury.

NOTICE

NOTICE is used to address practices not related to personal injury.

CAUTION

CAUTION, without the safety alert symbol, is used to address practices not related to personal injury.

General Tool Safety Warnings



WARNING Read all safety warnings and instructions. Failure to follow the warnings and instructions may result in electric shock, fire and/or serious injury. Save all warnings and instructions for future reference.

1. KEEP GUARDS IN PLACE and in working order.
2. REMOVE ADJUSTING KEYS AND WRENCHES. Form habit of checking to see that keys and adjusting wrenches are removed from tool before turning it on.
3. KEEP WORK AREA CLEAN. Cluttered areas and benches invite accidents.
4. DON'T USE IN DANGEROUS ENVIRONMENT. Don't use power tools in damp or wet locations, or expose them to rain. Keep work area well lighted.
5. KEEP CHILDREN AWAY. All visitors should be kept safe distance from work area.
6. MAKE WORKSHOP KID PROOF with padlocks, master switches, or by removing starter keys.

7. **DON'T FORCE TOOL.** It will do the job better and safer at the rate for which it was designed.
8. **USE RIGHT TOOL.** Don't force tool or attachment to do a job for which it was not designed.

RECOMMENDED MINIMUM WIRE GAUGE FOR EXTENSION CORDS (120 VOLT)				
NAMEPLATE AMPERES (at full load)	EXTENSION CORD LENGTH			
	25'	50'	100'	150'
0 – 6	18	16	16	14
6.1 – 10	18	16	14	12
10.1 – 12	16	16	14	12
12.1 – 16	14	12	Do not use.	

TABLE A

9. **USE PROPER EXTENSION CORD.** Make sure your extension cord is in good condition. When using an extension cord, be sure to use one heavy enough to carry the current your product will draw. An undersized cord will cause a drop in line voltage resulting in loss of power and overheating. Table A shows the correct size to use depending on cord length and nameplate ampere rating. If in doubt, use the next heavier gage. The smaller the gage number, the heavier the cord.
10. **WEAR PROPER APPAREL.** Do not wear loose clothing, gloves, neckties, rings, bracelets, or other jewelry which may get caught in moving parts. Nonslip footwear is recommended. Wear protective hair covering to contain long hair.
11. **ALWAYS USE SAFETY GLASSES.** Also use face or dust mask if cutting operation is dusty. Everyday eye-

- glasses only have impact resistant lenses, they are NOT safety glasses.
12. **SECURE WORK.** Use clamps or a vise to hold work when practical. It's safer than using your hand and it frees both hands to operate tool.
13. **DON'T OVERREACH.** Keep proper footing and balance at all times.
14. **MAINTAIN TOOLS WITH CARE.** Keep tools sharp and clean for best and safest performance. Follow instructions for lubricating and changing accessories.
15. **DISCONNECT TOOLS** before servicing; when changing accessories, such as blades, bits, cutters, and the like.
16. **REDUCE THE RISK OF UNINTENTIONAL STARTING.** Make sure switch is in off position before plugging in.
17. **USE RECOMMENDED ACCESSORIES.** Consult the owner's manual for recommended accessories. The use of improper accessories may cause risk of injury to persons.
18. **NEVER STAND ON TOOL.** Serious injury could occur if the tool is tipped or if the cutting tool is unintentionally contacted.
19. **CHECK DAMAGED PARTS.** Before further use of the tool, a guard or other part that is damaged should be carefully checked to determine that it will operate properly and perform its intended function – check for alignment of moving parts, binding of moving parts, breakage of parts, mounting, and any other conditions that may affect its operation. A guard

or other part that is damaged should be properly repaired or replaced.

20. DIRECTION OF FEED. Feed work into a blade or cutter against the direction of rotation of the blade or cutter only.
21. NEVER LEAVE TOOL RUNNING UNATTENDED. TURN POWER OFF. Don't leave tool until it comes to a complete stop.

Table Saw Safety Warnings

For Your Own Safety Read Instruction Manual Before Operating Saw

1. Wear eye protection.
2. Use saw-blade guard and spreader for every operation for which it can be used, including all through sawing.
3. Keep hands out of the line of saw blade.
4. Use a push-stick when required.
5. Know how to reduce risk of kickback.
6. Do not perform any operation free-hand.
7. Never reach around or over saw blade.
8. Make sure the workpiece is supported at all times while sawing. Use a roller stand (not provided) with larger workpieces if necessary.
9. To properly understand all safety warnings, be familiar with the following safety terms and equipment:
 - a. Featherboard – A block with “fingers” that hold the workpiece against the fence while sawing.
 - b. Through-sawing – A cut made from one side of a board to the opposite side, without stopping.
 - c. Ripcut or Ripping - A cut made parallel to (along with) the grain of the wood.
 - d. Crosscut or Crosscutting - A cut made perpendicular (at a 90° angle) to the grain of the wood.
 - e. Push-stick – A narrow strip of wood or other soft material with a notch cut into one end and which is used to push short pieces of material through saws. It provides a safe distance between the hands and the cutting tool. Must be narrower than the cut width to prevent contact with the blade.
 - f. Freehand – Feeding a workpiece through the saw without using a fence or guided support to guide it. **NOT A SAFE METHOD.**
 - g. Kerf – The gap made by the saw in the workpiece.
 - h. Kickback – A sudden reaction to a pinched, bound, or misaligned blade, causing an uncontrolled workpiece to lift up and out of the saw toward the operator.
 - i. Spreader – A metal plate that follows the saw blade to keep the kerf (gap) from closing on the saw blade. Spreaders, except riving knives, must be aligned to the blade after blade adjustment to prevent binding.
 - j. Riving Knife – A spreader mounted on the same mechanism as the blade. Generally more effective than simple spreaders.
10. As noted previously, **Kickback** is a sudden reaction to a pinched, bound, or misaligned blade, causing an un-

controlled workpiece to lift up and out of the saw toward the operator.

Kickback is usually a result of tool misuse and can be limited or avoided by following the precautions below:

- Fence must be completely parallel to the saw blade.
 - Workpiece must be free from flaws (such as loose knots) and from foreign objects (such as nails and screws).
 - Support large workpieces along their entire length. Large workpieces tend to bend, grabbing the blade.
 - Do not use a dull, damaged, or pitch-covered blade.
 - Do not use fence as a guide when crosscutting.
 - Do not ripcut a twisted or warped workpiece, or workpiece without straight edge to guide along fence.
 - Maintain control of the workpiece. Do not allow the workpiece to rest against the moving blade without holding onto it.
 - If the blade binds or a cut is interrupted, turn off the power switch and hold the workpiece still until the blade stops. Correct the cause of blade binding before proceeding.
 - Before continuing an unfinished cut, center the blade in the pre-cut kerf and check that the saw teeth are not engaged into the workpiece before turning on the saw.
 - Push the wood stock past the blade prior to release.
11. Check guards for proper operation with saw disconnected from power before each use. Do not disable any guard. Do not operate saw if any
 - movable guard does not move freely and close instantly. Make sure any movable guard does not touch the blade in all angles, depths of cut, and positions.
 12. Keep the guard in place while through-sawing. Verify that the spreader lines up with the blade to prevent binding.
 13. Construct a Push Stick out of Wood according to the guidelines on the following page The use of accessories or attachments not recommended by the manufacturer may result in a risk of injury to persons. See next page for Push Stick Features and Functions.

Essential Straight Push-stick Features and Functions

Note: Straight style (traditional) stick shown. A different stick design may be used if it properly protects against all hazards.

Diagram not to scale.

- Push sticks must be made from sturdy, defect-free, plywood or normal wood to prevent unexpected breakage. Material must be at least 1/4" thick, but no thicker than the finished wood.
- Inspect push stick before use and do not use a damaged or deteriorated push stick.
- Push stick dimensions will vary depending on the application and user.

Handle Notch

- Must be far enough down the stick to allow a comfortable and firm grip.
- Must be deep enough to prevent hand from slipping down the stick.
- Do not cut more than halfway into the stick to prevent weakening.
- Corners may be rounded to increase comfort.

Stick Length

- Must be long enough to prevent accidental blade contact.
- At least 6" from end of handle to closest part of notch.

Notch

- Must be right angle cut 30°-40° from the angle of the stick to keep hands out of the line of the blade.
- The lower lip of the notch must be no longer than the workpiece is thick.

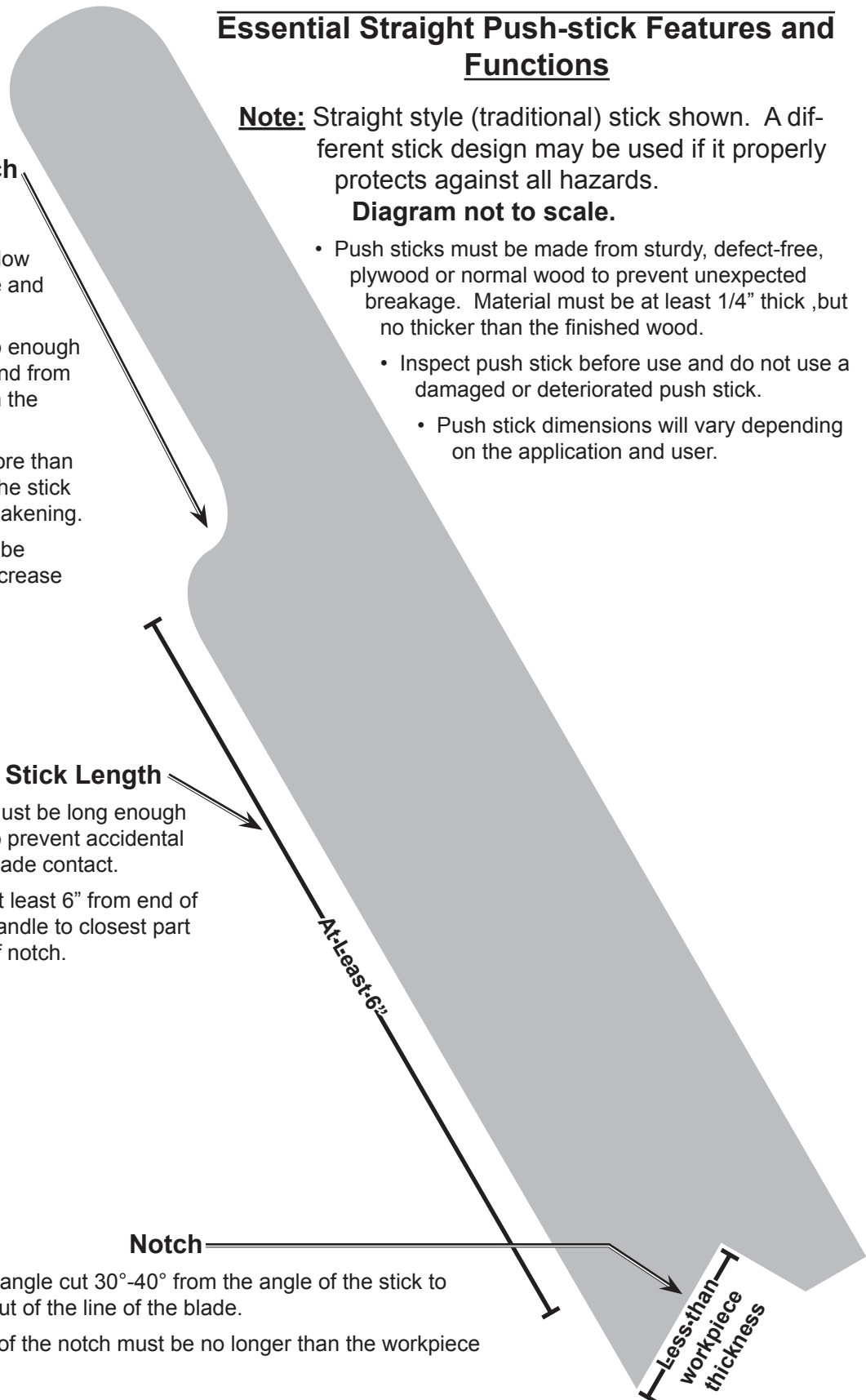

14. When servicing use only identical replacement parts.
15. Only use safety equipment that has been approved by an appropriate standards agency. Unapproved safety equipment may not provide adequate protection. Eye protection must be ANSI-approved and breathing protection must be NIOSH-approved for the specific hazards in the work area.
16. Industrial applications must follow OSHA guidelines.
17. Maintain labels and nameplates on the tool. These carry important safety information. If unreadable or missing, contact Harbor Freight Tools for a replacement.
18. Avoid unintentional starting. Prepare to begin work before turning on the tool.
19. People with pacemakers should consult their physician(s) before use. Electromagnetic fields in close proximity to heart pacemaker could cause pacemaker interference or pacemaker failure. In addition, people with pacemakers should:
 - Avoid operating alone.
 - Do not use with power switch locked on.
 - Properly maintain and inspect to avoid electrical shock.
 - Any power cord must be properly grounded. Ground Fault Circuit Interrupter (GFCI) should also be implemented – it prevents sustained electrical shock.
20. Some dust created by power sanding, sawing, grinding, drilling, and other construction activities, contains

chemicals known [to the State of California] to cause cancer, birth defects or other reproductive harm. Some examples of these chemicals are:

- Lead from lead-based paints
- Crystalline silica from bricks and cement or other masonry products
- Arsenic and chromium from chemically treated lumber

Your risk from these exposures varies, depending on how often you do this type of work. To reduce your exposure to these chemicals: work in a well ventilated area, and work with approved safety equipment, such as those dust masks that are specially designed to filter out microscopic particles. (California Health & Safety Code § 25249.5, *et seq.*)

21. **WARNING:** Handling the cord on this product will expose you to lead, a chemical known to the State of California to cause cancer, and birth defects or other reproductive harm. Wash hands after handling. (California Health & Safety Code § 25249.5, *et seq.*)
22. The warnings, precautions, and instructions discussed in this instruction manual cannot cover all possible conditions and situations that may occur. It must be understood by the operator that common sense and caution are factors which cannot be built into this product, but must be supplied by the operator.

Vibration Safety

This tool vibrates during use. Repeated or long-term exposure to vibration may cause temporary or permanent physical injury, particularly to the hands, arms and shoulders. To

reduce the risk of vibration-related injury:

1. Anyone using vibrating tools regularly or for an extended period should first be examined by a doctor and then have regular medical check-ups to ensure medical problems are not being caused or worsened from use. Pregnant women or people who have impaired blood circulation to the hand, past hand injuries, nervous system disorders, diabetes, or Raynaud's Disease should not use this tool. If you feel any medical or physical symptoms related to vibration (such as tingling, numbness, and white or blue fingers), seek medical advice as soon as possible.
2. Do not smoke during use. Nicotine reduces the blood supply to the hands and fingers, increasing the risk of vibration-related injury.
3. Wear suitable gloves to reduce the vibration effects on the user.
4. Use tools with the lowest vibration when there is a choice between different processes.
5. Include vibration-free periods each day of work.
6. Grip tool as lightly as possible (while still keeping safe control of it). Let the tool do the work.
7. To reduce vibration, maintain the tool as explained in this manual. If any abnormal vibration occurs, stop use immediately.



**SAVE THESE
INSTRUCTIONS.**

GROUNDING INSTRUCTIONS

⚠ WARNING



**TO PREVENT
ELECTRIC SHOCK**

**AND DEATH FROM
INCORRECT GROUNDING
WIRE CONNECTION
READ AND FOLLOW THESE
INSTRUCTIONS:**

Grounded Tools: Tools with Three Prong Plugs

1. In the event of a malfunction or breakdown, grounding provides a path of least resistance for electric current to reduce the risk of electric shock. This tool is equipped with an electric cord having an equipment-grounding conductor and a grounding plug. The plug must be plugged into a matching outlet that is properly installed and grounded in accordance with all local codes and ordinances.
2. Do not modify the plug provided – if it will not fit the outlet, have the proper outlet installed by a qualified electrician.
3. Improper connection of the equipment-grounding conductor can result in a risk of electric shock. The conductor with insulation having an outer surface that is green with or without yellow stripes is the equipment-grounding conductor. If repair or replacement of the electric cord or plug is necessary, do not connect the equipment-grounding conductor to a live terminal.
4. Check with a qualified electrician or service personnel if the grounding instructions are not completely under-

stood, or if in doubt as to whether the tool is properly grounded.

5. Use only 3-wire extension cords that have 3-prong grounding plugs and 3-pole receptacles that accept the tool's plug.
6. Repair or replace damaged or worn cord immediately.

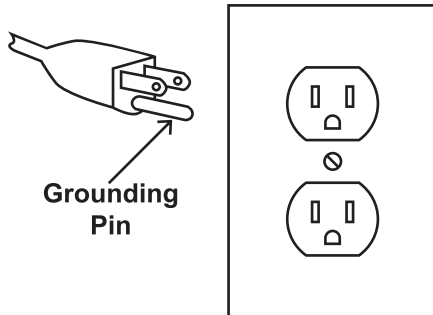

125 V~ 3-Prong Plug and Outlet
(for up to 125 V~ and up to 15 A)

7. This tool is intended for use on a circuit that has an outlet that looks like the one illustrated above in **125 V~ 3-Prong Plug and Outlet**. The tool has a grounding plug that looks like the plug illustrated above in **125 V~ 3-Prong Plug and Outlet**.
8. The outlet must be properly installed and grounded in accordance with all codes and ordinances.
9. Do not use an adapter to connect this tool to a different outlet.

Double Insulated Tools: Tools with Two Prong Plugs

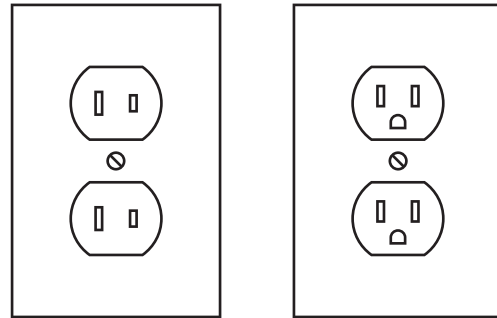

Outlets for 2-Prong Plug

1. To reduce the risk of electric shock, double insulated equipment has a polarized plug (one blade is wider than the other). This plug will fit in a polarized outlet only one way. If the plug does not fit fully in the outlet, reverse the plug. If it still does not fit, contact a qualified electrician to install the proper outlet. Do not change the plug in any way.
2. Double insulated tools may be used in either of the 120 volt outlets shown in the preceding illustration. **(See Outlets for 2-Prong Plug.)**

SPECIFICATIONS

Electrical Requirements	120 V~ / 60 Hz / 15 A
Motor No Load Speed	4800 RPM
Blade Diameter	10"
Arbor Diameter	5/8"
Table Surface	16"x 26"
Cutting Depth at 0°	3"
Cutting Depth at 45°	2-3/8"
Overload Protection	Breaker Switch



UNPACKING

When unpacking, make sure that the item is intact and undamaged. If any parts are missing or broken, please call Harbor Freight Tools at the number shown on the cover of this manual as soon as possible.

INSTRUCTIONS FOR PUTTING INTO USE



Read the **ENTIRE IMPORTANT SAFETY INFORMATION** section at the beginning of this manual including all text under subheadings therein before set up or use of this product.

WARNING

TO PREVENT SERIOUS INJURY FROM ACCIDENTAL OPERATION:

Turn the Power Switch of the tool to its "OFF" position, remove key, and unplug the tool from its electrical outlet before assembling or making any adjustments to the tool.

Note: For additional information regarding the parts listed in the following pages, refer to the Assembly Diagram near the end of this manual.

Assembly

To Install Handwheel (29)

1. Remove the Bolt (27) from the Screw Rod (54).
2. Place the Handwheel onto the Screw Rod. Fasten into place by using the Bolt.

To Assemble Blade Guard (113)

1. Unplug the Saw and remove the Switch Key (16).
2. Position the Blade (96) 90° to the table and lock in place.
3. Position the recessed end of the Splitter Bracket (119) against the end of the Pivot Plate (117) and fasten in place using the Spring Washer (3), Mat Washer (4) and Bolt (116).

Please note: Do not fully tighten the Bolt at this time.

4. Remove the Wing Nut (121), Flat Washer (50) and Spring Washer (3) from Splitter Bracket.
5. Position the Splitter (131) against the Splitter Bracket. Make sure the tabs on the Splitter Bracket are **INSIDE** the slot of the Splitter.
6. Replace the Wing Nut (121), Flat Washer (50) and Spring Washer (3).
7. Make sure there is at least a 1/8" gap between the bottom edge of the Splitter and the top surface of the Table

(109) and that the tabs are on the INSIDE slot of the Splitter.

8. Use a framing square (not included) to make sure the Saw Blade and Splitter assembly are square. If not square, loosen the Splitter Bracket and adjust until the Splitter is properly aligned with the Saw Blade. Then tighten all screws and bolts.

Mounting

1. The Saw MUST be properly secured to the supporting surface using the four mounting holes at each corner of the Base (5).
2. If mounting Table Saw to a leg stand (not included), insert screws through the holes in each corner and into the pre-drilled holes in the leg stand. Tighten together using washers, flat washers and nuts (hardware not included.)
3. If placing Table Saw on support surface, insert the Rubber Feet (1) into each corner of the Base to dampen the vibration.

Please note: Before the Table Saw is placed on supporting surface, please verify that supporting surface has a 11"-12" square hole to allow for sawdust to fall through and be removed.

4. If the supporting surface does not have the hole, square the Table Saw on the supporting surface and mark the location of the four 5/16" holes to be drilled.
5. Locate and mark an 11"-12" square that is centered between the four mounting holes. Once marked, cut out and remove the square. This

will allow sawdust to fall through the Table Saw's Base.

6. Securely fasten the Table Saw to the supporting surface using washers, flat washers and nuts (hardware not included.)
7. **WARNING!** Failure to provide this sawdust removal hole will allow sawdust to build up around the motor, which can potentially lead to a fire hazard and/or damage the motor assembly.

OPERATING INSTRUCTIONS



Read the **ENTIRE IMPORTANT SAFETY INFORMATION** section at the beginning of this manual including all text under subheadings therein before set up or use of this product.

Table Saw Adjustments



TO PREVENT SERIOUS INJURY

FROM ACCIDENTAL OPERATION:

Turn the Power Switch of the tool to its "OFF" position, remove key, and unplug the tool from its electrical outlet before performing any inspection, maintenance, or cleaning procedures.

WARNING! Check the Blade Guard assembly before and after every use.

Blade Depth and Angle Adjustment

1. The Blade (96) depth should be set so that outer points of the Blade are 1/8" to 1/4" higher than the workpiece while the lowest points are below the workpiece.
2. To raise the Blade, turn the Handwheel (29) counterclockwise.
3. To lower the Blade, turn the Handwheel clockwise.
4. To adjust the Blade's angle, loosen the Bevel Lock Knob (62) and then turn the Handwheel until the Blade reaches the desired angle. Then tighten the Bevel Lock Knob. See **Figure A**, below.

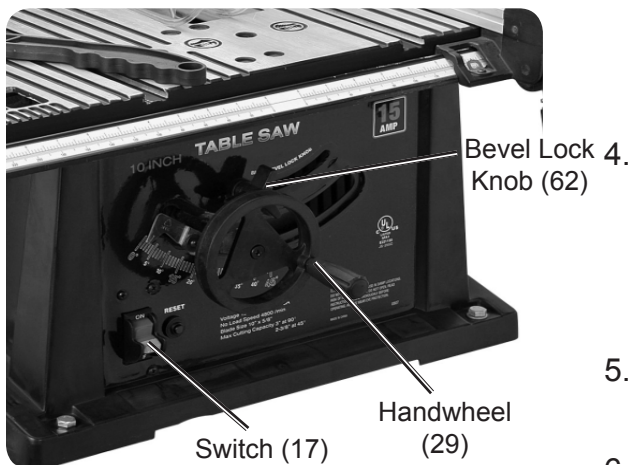

FIGURE A

5. When the Blade is tilted to the left as far as it will go, the Blade should be at a 45° angle to the Saw Table and the Bevel Indicator on the Ruler (13) should point to 45°.
6. When the Blade is tilted to the right as far as it will go, the Blade should be at a 90° angle to the Saw Table and the Bevel Indicator on the Ruler should point to 0°.

7. Please note: When the Blade is at 90° to the Table Saw, the Blade should be square with the Saw Table.
8. **WARNING!** The Bevel Lock Knob must be tightened during all cutting operations.

45° and 90° Positive Stop Adjustment

1. The Table Saw is equipped with positive stops for rapid and accurate positioning of the Blade at 45° and 90° to the table.
2. Before making ANY adjustments, make sure the Table Saw is unplugged and the Switch is removed.
3. To adjust the positive stop at 90°, loosen the Bevel Lock Knob and move as far to the left as possible. Then tighten the Knob.
4. Place a level or square (not included) on the Table (109) with one end blade to make sure Blade is at 90°. If not, loosen the Bolt (110) a few turns and tilt Blade until at the correct angle.
5. Tighten the Bevel Lock Knob and then tighten the Bolt (110).
6. To adjust the positive stop at 45°, loosen the Bevel Lock Knob and move as far to the right as possible. Then tighten the Knob.
7. Place a level or square on the Table with one end blade to make sure Blade is at 45°. If not, loosen the Bolt (111) a few turns and tilt Blade until at the correct angle.
8. Tighten the Bevel Lock Knob and then tighten the Bolt (111).

Aligning and Adjusting the Rip Fence (146)

1. **WARNING!** A misaligned Fence can cause kickbacks and jams. To reduce risk of injury, always maintain proper Fence alignment. The Rip Fence must be parallel with the Blade and Table grooves.
2. Lift up the Fence Handle (26) and move the Fence along the gauge slot until sliding it to the desired location.
3. Verify that Fence is parallel, then push down on the Handle to lock the Fence in place.
4. A Draw Pole (132) locks the Fence in place. To adjust the Draw Pole, loosen the Bolt (20) that connects the Draw Pole to the Fence.
5. **WARNING!** The Fence must be properly aligned to the gauge slot to prevent kickback during ripping.
6. To check for proper alignment, position the Fence next to the gauge slot and clamp Fence to the Table by pushing down on Fence Handle. Once locked, the edge of the Fence should be parallel to the gauge slot.

Adjusting Table Insert (112)

1. Lower the Blade by turning the Hand-wheel clockwise.
2. Loosen the two Table Insert Bolts (12).
3. Adjust the Table Insert and retighten, making sure to not overtighten. Doing so can cause the Table Insert to bow or bend.
4. If the Table Insert is slightly above the Table, tighten the two Table Insert Bolts until the Table Insert is flush

with or slightly below the Table surface.

Miter Gauge (100) Operation and Adjustment

1. When straight cross-cutting (the Blade is set at 90° to the Table) the Miter Gauge can be used in either table slot.
2. When bevel cross-cutting (the Blade is tilted away) only use the Miter Gauge in the right table slot where the Blade is titled away from the Miter Gauge and your hands.
3. To operate the Miter Gauge, loosen the Gauge's Lock Knob (101) and move the Gauge to the desired angle, then tighten Knob.

Adjusting Blade Parallel To Miter Gauge Slots

1. **WARNING!** Make sure to unplug Table Saw before making any adjustments to Blade.
2. To prevent kickback and ensure accurate cuts when cutting, the Blade's angle in relation to the Miter Gauge should be regularly checked. If any adjustments are needed:
3. Remove the Blade Guard (113).
4. Raise the Blade to its highest position and adjust to Blade so that it is 90° to the Table.
5. Mark a Blade tooth at the front of the Table Saw with a marker.
6. Using a square or ruler (not included), place the square against the Miter Gauge slot and adjust the flat

edge of the square until it touches the marked tooth.

7. Rotate the Blade and check the same marked tooth at the rear of the Table Saw.
8. If the front and rear measurements are not identical, have a qualified service technician repair the Table Saw.

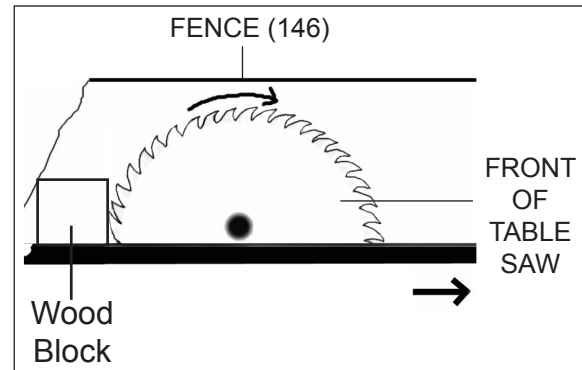

FIGURE B

Installing/Replacing Saw Blade

1. **WARNING!** Make sure to unplug Table Saw before making any installing or replacing Blade.
2. **WARNING!** Use only a 10" diameter saw blade rated at 4800 RPM and with a 5/8" arbor hole.
3. Remove the Blade Guard, raise the Saw Blade to its maximum height and remove the Table Insert.
4. Use the Wrench (145) to keep the Saw arbor from rotating while using the Pin Wrench (147) to remove the Arbor Nut. Turn the nut counterclockwise to remove. Then remove the Outer Flange (97) and the Blade.
5. Place new 10" Blade onto the Arbor Shaft (94), making sure the teeth point DOWN at the front of the Table Saw.
6. **WARNING!** The teeth MUST point down toward the front of the Table Saw for proper operation. See **Figure B**, above. Incorrect blade installation can damage the Saw Blade, Table Saw and/or workpiece.
7. Place the Outer Flange onto the Arbor Shaft. Be sure the hollow side of the Flange is against the Blade and that all pieces are snug against the arbor housing.
8. Thread the Arbor Nut back onto the Arbor. Tighten with the Wrench (145), turning the nut clockwise and holding the Arbor steady with the Pin Wrench.
9. Rotate the Blade to make sure it turns freely. Then lower the Blade.
10. Replace the Table Insert and retighten the Table Insert screw.
11. **WARNING!** Do not overtighten screw. Doing so can cause the Table to bow or bend, leading to serious injury.

Work Piece and Work Area Set Up

1. Designate a work area that is clean and well-lit. The work area must not allow access by children or pets to prevent injury and distraction.
2. Route the power cord along a safe route to reach the work area without creating a tripping hazard or exposing the power cord to possible damage. The power cord must reach the work area with enough extra length to allow free movement while working.
3. Secure loose work pieces using a vise or clamps (not included) to prevent movement while working.
4. There must not be hazardous objects, such as utility lines or foreign objects, nearby that will present a hazard while working.

General Operating Instructions

1. The ON/OFF Switch (17) is located on the Table Saw's front panel. To activate the Table Saw, turn the switch to "ON". To turn off the Table Saw, turn the switch to "OFF."
2. When the Table Saw is "OFF," keep the Switch locked in the OFF position. Do this by grasping the Switch and pulling it out of the Switch Box (21). The Table Saw will not operate with the Switch removed.
3. Please note: The Switch can be removed while the Table Saw is running. But it cannot be restarted without inserting the Switch back into the Switch Box.
4. The Table Saw is also equipped with a manual reset overload protector. If the motor shuts off or fails to start

because of overloading (such as cutting stock too fast or when using a dull blade), first turn the Switch to the "OFF" position.

5. Remove the stock and check Blade condition.
6. Let the motor cool for 3-5 minutes and push the Reset Button (16), which will reset the overload device. Turn the motor on by turning the Switch to "ON."
7. **WARNING!** Be sure to immediately turn off the Table Saw if the overload protector stops the motor.

Avoiding Kickback

1. The Table Saw can be used for straight-line cutting, such as cross cutting, ripping, mitering, beveling and compound cutting. However, kickback can occur when the Blade stalls, a cut is made at an incorrect depth, or you saw into a knot or nail. To avoid kickback, do the following:
2. Use the correct blade depth setting. The top blade teeth should clear the workpiece by 1/8" to 1/4".
3. Inspect the workpiece for knots or nails before beginning a cut. Knock out any loose knots with a hammer and do not saw into loose knot or nail.
4. Use the Fence when rip cutting and the Miter Gauge when cross-cutting.
5. Use clean, sharp and properly-set blades. Do not use dull blades.
6. Support the workpiece properly to avoid pinching.

7. When making a cut, use steady and even pressure. Do not force cuts.
8. Do not cut wet or warped lumber.
9. Hold the workpiece firmly with both hands or use the included Push Stick (53). Make sure the Push Stick is narrower than the workpiece and has 90° notch on one end and shaping for a grip on the other end.
10. A push block (not included) can be used with non-through cuts. **CAUTION:** Make sure the push block's screws are recessed before using on Table Saw.

Making a Cross-cut

1. **WARNING!** Using the Fence as a cutoff gauge when cross-cutting will result in kickback, which can lead to serious injury and property damage.
2. Remove the Fence.
3. Turn the Handwheel counterclockwise until the Blade is set at the correct depth for the workpiece.
4. Set the Miter Gauge at the desired angle and lock into place using the Adjusting Knob.
5. Place a support (not included) that is the same height as the Table Saw behind the Saw.
6. Turn the Switch to "ON."
7. Let the Blade build up to full speed before moving the workpiece into the Blade from the front of the Saw.
8. **WARNING!** To prevent injury, place hand closest to Blade on the Miter Gauge Adjusting Knob and keep

Hand furthest from Blade on the workpiece.

9. Once cut is made, turn off Table Saw. Wait for Blade to come to complete stop before removing any part of workpiece.

Making a Rip-cut

1. Turn the Handwheel counterclockwise until Blade is set to correct depth of workpiece.
2. Set the Blade to 0° and position Fence at desired distance from Blade for cut. Lock Fence in place.
3. Place a support (not included) that is the same height as the Table Saw behind the Saw.
4. Make sure wood is clear of Blade before turning on Table Saw.
5. Use Push Stick or push block to move the wood through the cut and past the Blade. **WARNING!** Do not push a small piece of wood into the Blade with your hand. Always use Push Stick or push block. See **Figure C**, below.

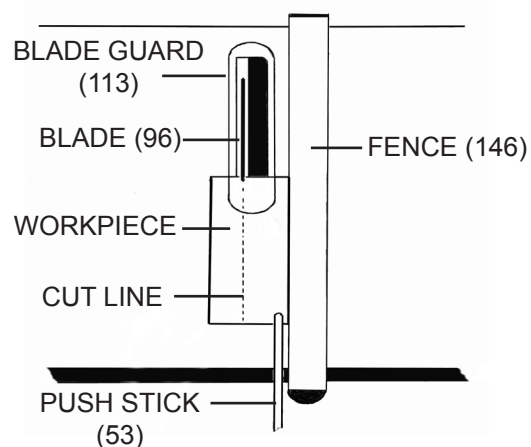

FIGURE C
(VIEW FROM ABOVE)

To reduce possible injury should kickback occur, stand to side of the workpiece as it contacts the Blade.

WARNING! Do not stand in the line of cut.

6. Once cut is made, turn off Table Saw. Wait for Blade to come to complete stop before removing any part of workpiece.

Making a Bevel Rip-cut

1. **WARNING!** The Fence must be on the right side of the Blade to avoid trapping the wood and causing kickback. Placing the Fence to the left of the Blade with result in kickback and lead to potential injury and property damage.
2. If ripping a piece larger than 36" long, place a support that is the same height as the table behind the saw to support the workpiece.
3. Keep wood clear of Blade before turning on Table Saw.
4. Position workpiece flat on Table with the edge flush against the Fence. Let Blade build up to full speed before feeding workpiece into Blade.
5. Use Push Stick or push block to slowly feed workpiece toward the Blade from the front.
6. **WARNING!** Stand slightly to the side of the wood to reduce chance of injury.
7. Once Blade has made contact with the workpiece, use the hand closer to Fence to guide it.
8. Make sure edge of workpiece remains in solid contact with both

Fence and surface of Blade. If ripping a narrow workpiece, use Push Stick to move piece through cut and past the Blade.

9. Once cut is made, turn off Table Saw. Wait for Blade to come to complete stop before removing any part of workpiece.
10. After the Blade has fully stopped, remove the cutoff stock.

MAINTENANCE AND SERVICING



Procedures not specifically explained in this manual must be performed only by a qualified technician.

⚠️ WARNING

TO PREVENT SERIOUS INJURY

FROM ACCIDENTAL OPERATION:

Turn the Power Switch of the tool to its “OFF” position and unplug the tool from its electrical outlet before performing any inspection, maintenance, or cleaning procedures.

TO PREVENT SERIOUS INJURY FROM TOOL FAILURE:

Do not use damaged equipment. If abnormal noise or vibration occurs, have the problem corrected before further use.

4. To maintain the surface of the Table, periodically apply paste wax and buff to keep Table surface smooth. **WARNING!** Do not wax the working face of Miter Gauge. Doing so may cause a workpiece to slip during cutting, leading to possible injury.
5. **AFTER USE**, clean out sawdust from underneath Table Saw and in Blade teeth. Use a resin solvent on the blade teeth. Dry with soft cloth.
6. Use soft, damp cloth to clean plastic parts. **WARNING!** Do not use any aerosol or petroleum-based solvents. Doing so can weaken or destroy plastic, causing property damage and leading to potential personal injury.
7. **⚠️ WARNING!** If the supply cord of this power tool is damaged, it must be replaced only by a qualified service technician.

Cleaning, Maintenance, and Lubrication

1. **BEFORE EACH USE**, inspect the general condition of the tool. Check for loose screws, misalignment or binding of moving parts, cracked or broken parts, damaged electrical wiring, and any other condition that may affect its safe operation.
2. Check the Blade Guard assembly before and after every use.
3. **AFTER USE**, clean external surfaces of the tool with clean cloth. .

PARTS LIST

Part	Description	Qty.
1	Rubber feet	4
2	Bolt M6×25	5
3	Spring washer	8
4	Mat washer	13
5	Base	1
7	Bolt ST4.2×14	5
8	Sheathing	2
9	Cable press plate	1
10	Bolt M4×16	9
11	Strengthen plank	1
12	Bolt M4×8	11
13	Ruler	1
14	Nut M4	4
15	Washer	3
16	Switch Key	1
17	Switch	1
19	Bolt ST4.8X20	2
20	Bolt	1
21	Switch box	1
22	Bolt	1
23	Power cord	1
24	Handle cover	2
25	Bolt M6×45	2
26	Handle	2
27	Bolt M6×16	1
28	Nut M6	3
29	Handwheel	1
30	Spring washer	3
31	Mat washer	2
32	Block plank	1
33	Bolt M6×85	1
34	Steel pipe	1
35	Lock nut M6	4
36	Front stand	1
37	Rear stand	1
38	Column pin	1
39	Steel pipe C	1
40	Column pin	2
41	Bolt	4
42	Mat washer	12
43	Spring washer	7
44	Bolt M5×14	4
45	Mat plate	1
46	Bolt M6×18	3
47	Big washer	3
48	Pin	1
49	Nut M10	4
50	Flat washer	1
51	Pointer	1
52	Steel pipe B	1
53	Push Stick	1
54	Screw rod	1

PARTS LIST

Part	Description	Qty.
55	Pointer	1
56	Pointer base	1
57	Lock nut M6	3
58	Bolt M6×16	1
59	Lock nut M8	2
60	Switch box mat	1
61	Line button	2
62	Bevel lock knob	1
63	Axis cover	1
64	Bolt M6×30	1
65	Turn axis	1
66	Mat piece	1
67	Support iron	1
68	Bolt M5×20	1
69	Bolt	2
70	Bolt	2
71	Linkage plate	1
72	Down-load	1
73	Brush cover	2
74	Carbon brush	4
75	Brush hold	2
76	Bolt	2
77	Input wind cover	1
78	Motor cover	1
79	Stator	1
80	Block wind circle	1
81	Bearing	1
82	Rotor	1
83	Bearing	1
84	Middle cover	1
85	Bearing	1
86	Spring block circle	1
87	Gear	1
88	Half circle key	1
89	Output axis	1
90	Spring block circle	1
91	Bearing	1
92	Front cover	1
93	Bolt M5×20	3
94	Arbor Shaft	1
96	Blade	1
97	Outer flange	1
98	Nut M14X1.5	1
99	Dial pointer	1
100	Miter Gauge	1
101	Miter Gauge Lock Knob	1
102	Mat plate	1
103	Column pin	1
104	Angle ruler button	1
105	Axis flange	6
106	Ruler	1
108	Bolt M6×20	6

PARTS LIST

Part	Description	Qty.
109	Table	1
110	Bolt M6×25	1
111	Bolt M6×35	1
112	Table insert	1
113	Blade Guard	1
114	Bolt M6×12	2
115	Nut M6	2
116	Pivot Bolt M6×50	1
117	Pivot Plate	1
118	Bolt M6X16	1
119	Splitter Bracket	1
120	Bolt M6×12	4
121	Wing Nut M6	1
122	Twist spring	1
123	Axis cover2	2
124	Block plate	1
125	Quakeproof mat	1
126	Bolt M6×40	1
127	Armature	2
128	Axis cover3	2
129	Column pin	1
130	Spring column pin	1

PARTS LIST

Part	Description	Qty.
131	Splitter	1
132	Draw pole	1
133	Clamp plate	1
134	Press spring	1
135	Ruler mat	1
136	Clamp plate	1
137	Spring piece	1
138	Wheel	1
140	Pin1	1
141	Pin2	1
142	Ruler stand	1
143	Bolt M6X12	2
144	Lock mat	2
145	Spanner	1
146	Rip Fence	1
147	Pin Wheel	1
148	Mat washer	2
149	Bolt M5X10	2
150	Nut M6	1
151	Bolt M4×10	1
152	Bolt M4×10	3
153	Bolt M5X10	8

PLEASE READ THE FOLLOWING CAREFULLY

THE MANUFACTURER AND/OR DISTRIBUTOR HAS PROVIDED THE PARTS LIST AND ASSEMBLY DIAGRAM IN THIS MANUAL AS A REFERENCE TOOL ONLY. NEITHER THE MANUFACTURER OR DISTRIBUTOR MAKES ANY REPRESENTATION OR WARRANTY OF ANY KIND TO THE BUYER THAT HE OR SHE IS QUALIFIED TO MAKE ANY REPAIRS TO THE PRODUCT, OR THAT HE OR SHE IS QUALIFIED TO REPLACE ANY PARTS OF THE PRODUCT. IN FACT, THE MANUFACTURER AND/OR DISTRIBUTOR EXPRESSLY STATES THAT ALL REPAIRS AND PARTS REPLACEMENTS SHOULD BE UNDERTAKEN BY CERTIFIED AND LICENSED TECHNICIANS, AND NOT BY THE BUYER. THE BUYER ASSUMES ALL RISK AND LIABILITY ARISING OUT OF HIS OR HER REPAIRS TO THE ORIGINAL PRODUCT OR REPLACEMENT PARTS THERETO, OR ARISING OUT OF HIS OR HER INSTALLATION OF REPLACEMENT PARTS THERETO.

Record Product's Serial Number Here: _____

Note: If product has no serial number, record month and year of purchase instead.

Note: Some parts are listed and shown for illustration purposes only, and are not available individually as replacement parts.

ASSEMBLY DIAGRAM

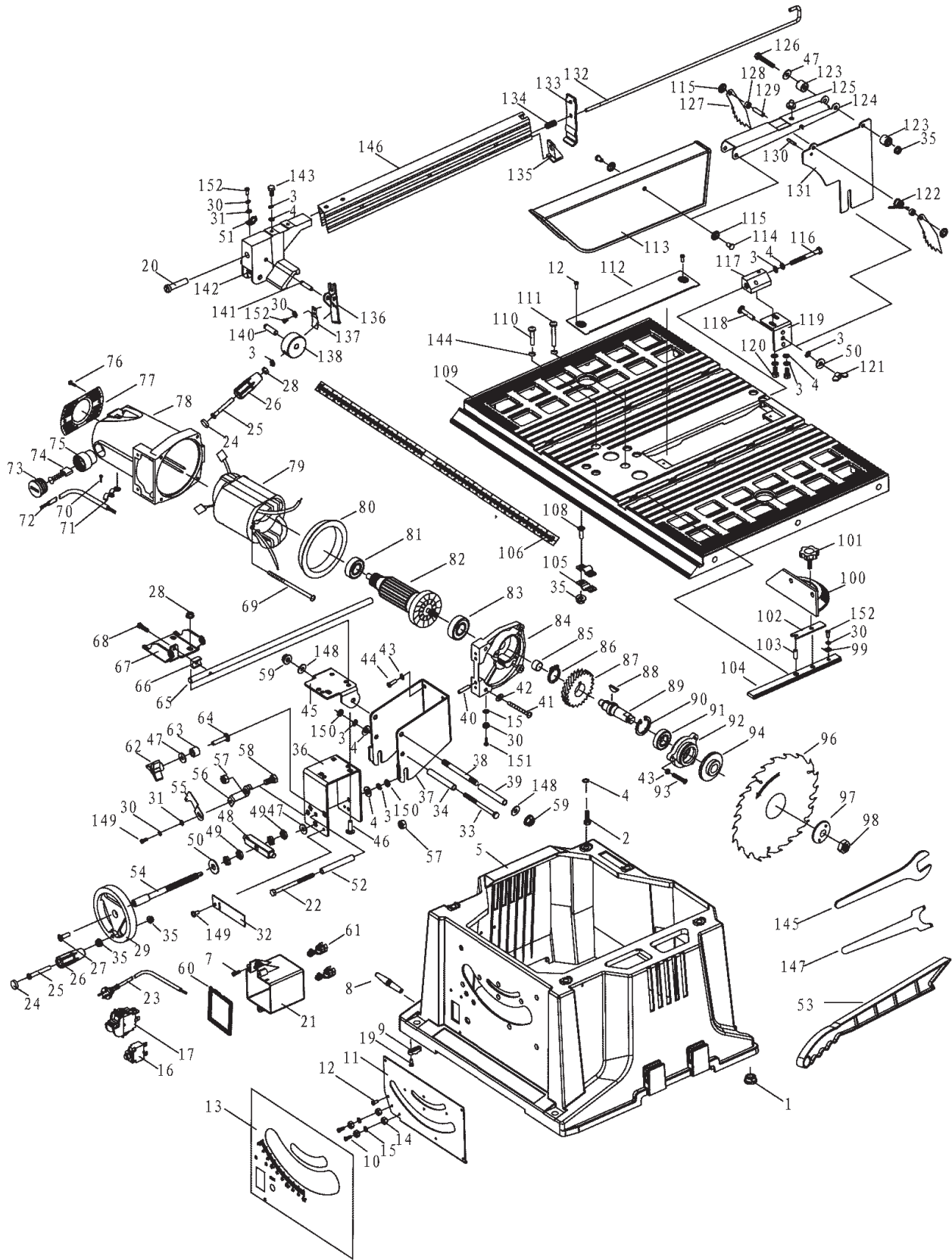

LIMITED 1 YEAR / 90 DAY WARRANTY

Harbor Freight Tools Co. makes every effort to assure that its products meet high quality and durability standards, and warrants to the original purchaser that for a period of ninety days from date of purchase that the engine/motor, the belts (if so equipped), and the blades (if so equipped) are free of defects in materials and workmanship. Harbor Freight Tools also warrants to the original purchaser, for a period of one year from date of purchase, that all other parts and components of the product are free from defects in materials and workmanship (90 days if used by a professional contractor or if used as rental equipment). This warranty does not apply to damage due directly or indirectly, to misuse, abuse, negligence or accidents, repairs or alterations outside our facilities, normal wear and tear, or to lack of maintenance. We shall in no event be liable for death, injuries to persons or property, or for incidental, contingent, special or consequential damages arising from the use of our product. Some states do not allow the exclusion or limitation of incidental or consequential damages, so the above limitation of exclusion may not apply to you. THIS WARRANTY IS EXPRESSLY IN LIEU OF ALL OTHER WARRANTIES, EXPRESS OR IMPLIED, INCLUDING THE WARRANTIES OF MERCHANTABILITY AND FITNESS.

To take advantage of this warranty, the product or part must be returned to us with transportation charges prepaid. Proof of purchase date and an explanation of the complaint must accompany the merchandise. If our inspection verifies the defect, we will either repair or replace the product at our election or we may elect to refund the purchase price if we cannot readily and quickly provide you with a replacement. We will return repaired products at our expense, but if we determine there is no defect, or that the defect resulted from causes not within the scope of our warranty, then you must bear the cost of returning the product.

This warranty gives you specific legal rights and you may also have other rights which vary from state to state.

3491 Mission Oaks Blvd. • PO Box 6009 • Camarillo, CA 93011 • (800) 444-3353

Free Manuals Download Website

<http://myh66.com>

<http://usermanuals.us>

<http://www.somanuals.com>

<http://www.4manuals.cc>

<http://www.manual-lib.com>

<http://www.404manual.com>

<http://www.luxmanual.com>

<http://aubethermostatmanual.com>

Golf course search by state

<http://golfingnear.com>

Email search by domain

<http://emailbydomain.com>

Auto manuals search

<http://auto.somanuals.com>

TV manuals search

<http://tv.somanuals.com>