



SANDER - 4" BELT & 6" DISC

Model 05154

ASSEMBLY AND OPERATING INSTRUCTIONS



3491 Mission Oaks Blvd., Camarillo, CA 93011
Visit our Web site at: <http://www.harborfreight.com>

Copyright© 2004 by Harbor Freight Tools®. All rights reserved. No portion of this manual or any artwork contained herein may be reproduced in any shape or form without the express written consent of Harbor Freight Tools.

For technical questions, please call 1-800-444-3353.

PRODUCT SPECIFICATIONS

Item	Description
Electrical Requirements	110V / 60 Hz / 1/2 HP / 1720 RPM / Single Phase.
Sanding Belt Size	4" x 36".
Sanding Disc Size	6" Diameter.
Sanding Belt Speed	1125 FPM (Feet Per Minute).
Sanding Disc Speed	1720 RPM (Revolutions Per Minute).
Table Surface Dimensions	7-1/2" x 5".
Table Tilt Capability	0° - 45°.
Additional Features	Miter Gauge / Adjustable Backstop.
Accessories	Hex Key.

SAVE THIS MANUAL

You will need this manual for the safety warnings and precautions, assembly, operating, inspection, maintenance and cleaning procedures, parts list and assembly diagram. Keep your invoice with this manual. Write the invoice number on the inside of the front cover. Keep this manual and invoice in a safe and dry place for future reference.

UNPACKING

When unpacking, check to make sure all the parts shown on the **Parts List on page 19** are included. If any parts are missing or broken, please call Harbor Freight Tools at the number shown on the cover of this manual as soon as possible.

GENERAL SAFETY RULES

 **WARNING!**
READ AND UNDERSTAND ALL INSTRUCTIONS
Failure to follow all instructions listed below may result in electric shock, fire, and/or serious injury.
SAVE THESE INSTRUCTIONS

WORK AREA

1. **Keep your work area clean and well lit.** Cluttered benches and dark areas invite accidents.
2. **Do not operate power tools in explosive atmospheres, such as in the presence of flammable liquids, gases, or dust.** Power tools create sparks

which may ignite the dust or fumes.

3. **Keep bystanders, children, and visitors away while operating a power tool.** Distractions can cause you to lose control. Protect others in the work area from debris such as chips and sparks. Provide barriers or shields as needed.

ELECTRICAL SAFETY

4. **Grounded tools must be plugged into an outlet properly installed and grounded in accordance with all codes and ordinances. Never remove the grounding prong or modify the plug in any way. Do not use any adapter plugs. Check with a qualified electrician if you are in doubt as to whether the outlet is properly grounded.** If the tools should electrically malfunction or break down, grounding provides a low resistance path to carry electricity away from the user.
5. **Double insulated tools are equipped with a polarized plug (one blade is wider than the other). This plug will fit in a polarized outlet only one way. If the plug does not fit fully in the outlet, reverse the plug. If it still does not fit, contact a qualified electrician to install a polarized outlet. Do not change the plug in any way.** Double insulation eliminates the need for the three wire grounded power cord and grounded power supply system.
6. **Avoid body contact with grounded surfaces such as pipes, radiators, ranges, and refrigerators.** There is an increased risk of electric shock if your body is grounded.
7. **Do not expose power tools to rain or wet conditions.** Water entering a power tool will increase the risk of electric shock.
8. **Do not abuse the Power Cord. Never use the Power Cord to carry the tools or pull the Plug from an outlet. Keep the Power Cord away from heat, oil, sharp edges, or moving parts. Replace damaged Power Cords immediately.** Damaged Power Cords increase the risk of electric shock.
9. **When operating a power tool outside, use an outdoor extension cord marked “W-A” or “W”.** These extension cords are rated for outdoor use, and reduce the risk of electric shock.

PERSONAL SAFETY

10. **Stay alert. Watch what you are doing, and use common sense when operating a power tool. Do not use a power tool while tired or under the influence of drugs, alcohol, or medication.** A moment of inattention while operating power tools may result in serious personal injury.

11. **Dress properly. Do not wear loose clothing or jewelry. Contain long hair. Keep your hair, clothing, and gloves away from moving parts.** Loose clothes, jewelry, or long hair can be caught in moving parts.
12. **Avoid accidental starting. Be sure the Power Switch is off before plugging in.** Carrying power tools with your finger on the Power Switch, or plugging in power tools with the Power Switch on, invites accidents.
13. **Remove adjusting keys or wrenches before turning the power tool on.** A wrench or a key that is left attached to a rotating part of the power tool may result in personal injury.
14. **Do not overreach. Keep proper footing and balance at all times.** Proper footing and balance enables better control of the power tool in unexpected situations.
15. **Use safety equipment.** Dust mask, non-skid safety shoes, hard hat, or hearing protection must be used for appropriate conditions.

TOOL USE AND CARE

16. **When using the Sanding Disc (12), firmly hold the workpiece with one hand and hold the Miter Guide (21) with the other hand. When using the Sanding Belt (45), firmly hold the workpiece with both hands.**
17. **Do not force the tool. Use the correct tool for your application.** The correct tool will do the job better and safer at the rate for which it is designed.
18. **Do not use the power tool if the Power Switch does not turn it on or off.** Any tool that cannot be controlled with the Power Switch is dangerous and must be replaced.
19. **Disconnect the Power Cord Plug from the power source before making any adjustments, changing accessories, or storing the tool.** Such preventive safety measures reduce the risk of starting the tool accidentally.
20. **Store idle tools out of reach of children and other untrained persons.** Tools are dangerous in the hands of untrained users.
21. **Maintain tools with care. Keep cutting tools sharp and clean.** Properly maintained tools with a sharp cutting edge are less likely to bind and are easier to control. Do not use a damaged tool. Tag damaged tools "Do not use" until repaired.

22. **Check for misalignment or binding of moving parts, breakage of parts, and any other condition that may affect the tool's operation. If damaged, have the tool serviced before using.** Many accidents are caused by poorly maintained tools.
23. **Use only accessories that are recommended by the manufacturer for your model.** Accessories that may be suitable for one tool may become hazardous when used on another tool.

SERVICE

24. **Tool service must be performed only by qualified repair personnel.** Service or maintenance performed by unqualified personnel could result in a risk of injury.
25. **When servicing a tool, use only identical replacement parts. Follow instructions in the “*Inspection, Maintenance, And Cleaning*” section of this manual.** Use of unauthorized parts or failure to follow maintenance instructions may create a risk of electric shock or injury.

GROUNDING



Improperly connecting the grounding wire can result in the risk of electric shock. Check with a qualified electrician if you are in doubt as to whether the outlet is properly grounded. Do not modify the power cord plug provided with the tool. Never remove the grounding prong from the plug. Do not use the tool if the power cord or plug is damaged. If damaged, have it repaired by a service facility before use. If the plug will not fit the outlet, have a proper outlet installed by a qualified electrician.

GROUNDED TOOLS: TOOLS WITH THREE PRONG PLUGS

1. Tools marked with “Grounding Required” have a three wire cord and three prong grounding plug. The plug must be connected to a properly grounded outlet. If the tool should electrically malfunction or break down, grounding provides a low resistance path to carry electricity away from the user, reducing the risk of electric shock. **(See Figure A, next page.)**
2. The grounding prong in the plug is connected through the green wire inside the cord to the grounding system in the tool. The green wire in the cord must be the only wire connected to the tool's grounding system and must never be attached to an electrically “live” terminal. **(See Figure A.)**

3. Your tool must be plugged into an appropriate outlet, properly installed and grounded in accordance with all codes and ordinances. The plug and outlet should look like those in the following illustration. **(See Figure A.)**

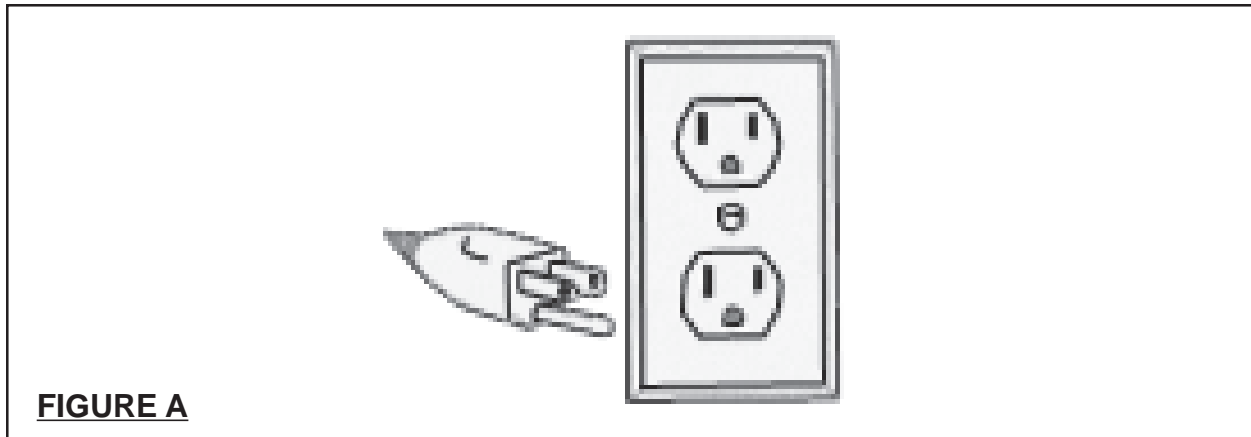

FIGURE A

DOUBLE INSULATED TOOLS: TOOLS WITH TWO PRONG PLUGS

1. Tools marked “Double Insulated” do not require grounding. They have a special double insulation system which satisfies OSHA requirements and complies with the applicable standards of Underwriters Laboratories, Inc., the Canadian Standard Association, and the National Electrical Code. **(See Figure B.)**
2. Double insulated tools may be used in either of the 120 volt outlets shown in the following illustration. **(See Figure B.)**

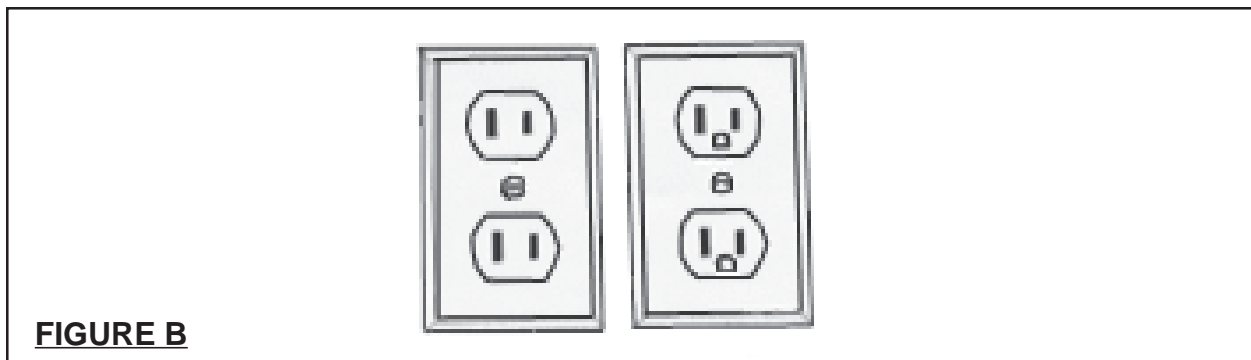

FIGURE B

EXTENSION CORDS

1. **Grounded** tools require a three wire extension cord. **Double Insulated** tools can use either a two or three wire extension cord.
2. As the distance from the supply outlet increases, you must use a heavier gauge extension cord. Using extension cords with inadequately sized wire causes a

serious drop in voltage, resulting in loss of power and possible tool damage.
(See Figure C.)

3. The smaller the gauge number of the wire, the greater the capacity of the cord. For example, a 14 gauge cord can carry a higher current than a 16 gauge cord.
(See Figure C.)
4. When using more than one extension cord to make up the total length, make sure each cord contains at least the minimum wire size required.
(See Figure C.)
5. If you are using one extension cord for more than one tool, add the nameplate amperes and use the sum to determine the required minimum cord size.
(See Figure C.)
6. If you are using an extension cord outdoors, make sure it is marked with the suffix "W-A" ("W" in Canada) to indicate it is acceptable for outdoor use.
7. Make sure your extension cord is properly wired and in good electrical condition. Always replace a damaged extension cord or have it repaired by a qualified electrician before using it.
8. Protect your extension cords from sharp objects, excessive heat, and damp or wet areas.

RECOMMENDED MINIMUM WIRE GAUGE FOR EXTENSION CORDS* (120 VOLT)					
NAMEPLATE AMPERES (At Full Load)	EXTENSION CORD LENGTH				
	25 Feet	50 Feet	75 Feet	100 Feet	150 Feet
0 – 2.0	18	18	18	18	16
2.1 – 3.4	18	18	18	16	14
3.5 – 5.0	18	18	16	14	12
5.1 – 7.0	18	16	14	12	12
7.1 – 12.0	18	14	12	10	-
12.1 – 16.0	14	12	10	-	-
16.1 – 20.0	12	10	-	-	-

* Based on limiting the line voltage drop to five volts at 150% of the rated amperes.

FIGURE C

SYMBOLOLOGY









	Double Insulated
	Canadian Standards Association
	Underwriters Laboratories, Inc.
	Volts Alternating Current
	Amperes
	No Load Revolutions per Minute (RPM)

FIGURE D

SPECIFIC SAFETY RULES

1. **Maintain a safe working environment.** Keep the work area well lit. Make sure there is adequate surrounding workspace. Always keep the work area free of obstructions, grease, oil, trash, and other debris. Do not use the Sander in areas near flammable chemicals, dusts, and vapors.
2. **Maintain labels and nameplates on the Sander.** These carry important information. If unreadable or missing, contact Harbor Freight Tools for a replacement.
3. **Never plug the Power Cord of this product into an electrical outlet while standing on a wet or damp surface.**
4. **Do not unplug the Sander by pulling on the Power Cord. Keep the Power Cord away from heated surfaces.**
5. **Use eye and breathing protection.** Always wear ANSI approved safety impact eye goggles and dust masks or an approved respirator.
6. **Always turn off the Sander and unplug the unit from its electrical outlet before performing any inspection, maintenance, or cleaning procedures.**
7. **Never leave the Sander unattended when it is plugged into an electrical outlet.** Make sure to unplug it from its electrical outlet before leaving the area.
8. **Do not allow children to handle or play with this product.**

9. **Store idle equipment.** When not in use, tools and equipment should be stored in a dry location to inhibit rust. Always lock up tools and equipment, and keep out of reach of children.
10. **Do not use this product if under the influence of alcohol or drugs.** Read warning labels on prescriptions to determine if your judgement or reflexes are impaired while taking drugs. If there is any doubt, do not attempt to use this product.
11. **Industrial applications must follow OSHA requirements.**
12. **Maintain this product with care.** Keep this product clean and dry for better and safer performance.
13. **Maintenance:** For your safety, service and maintenance should be performed regularly by a qualified technician.
14. **Check for damaged parts.** Before using this product, carefully check that it will operate properly and perform its intended function. Check for damaged parts and any other conditions that may affect the operation of this product. Replace or repair damaged or worn parts immediately.
15. **Use the right tool for the job.** Do not attempt to force a small tool or attachment to do the work of a larger industrial tool or attachment. There are certain applications for which this tool was designed. It will do the job better and more safely at the rate for which it was intended. Do not modify this tool, and do not use this tool for a purpose for which it was not intended.
16. **Reduce the risk of accidental starting.** Make sure the Power Switch (30) is in the "OFF" position before plugging the Power Cord (29) into a 110 volt, grounded, electrical outlet.
17. **Never stand on the Sander.** Serious personal injury can result if the machine is tipped or if a spinning Sanding Belt or Disc is contacted.
18. **Prior to starting the Sander, make sure all adjusting keys and wrenches are removed from the machine.**
19. **Before sanding, turn on the Sander and check for excessively loose Sanding Disc (12) or Belt (45).** If necessary, turn off the Sander and correct the problem before using.
20. **Always keep hands and fingers as far away as possible from the moving parts of the Sander.**

21. **Allow the Sanding Disc (11) and Sanding Belt (45) to spin up to full speed before feeding a workpiece into them.** When turning off the Sander, allow the Sanding Disc and Sanding Belt to slow down and stop on their own. Do not press against the Disc or Belt to stop them.
22. **Feed the workpiece into the Sanding Disc (12) and Sanding Belt (45) gradually and into the direction of rotation.** Do not attempt to force the Sander to remove material faster than it was designed to cut.
23. **To avoid damage to the machine, allow approximately 1/16" clearance between the Sanding Belt (45) and Work Support (33). Also allow approximately 1/16" clearance between the Sanding Disc (12) and the Work Table (13).**
24. **When sanding a large workpiece, make sure its entire length is properly supported.**
25. **Never attempt to remove material stuck in the moving parts of the Sander while it is plugged in and running.**
26. **Always turn the Power Switch (30) to its "OFF" position and unplug the Power Cord (29) from its electrical outlet before performing any inspection, maintenance, or cleaning procedures.**
25.  **WARNING!** Some dust created by power sanding, sawing, grinding, drilling and other construction activities, contain chemicals known (to the State of California) to cause cancer, birth defects or other reproductive harm. Some examples of these chemicals are: lead from lead-based paints, crystalline silica from bricks and cement or other masonry products, arsenic and chromium from chemically treated lumber. Your risk from these exposures varies, depending on how often you do this type of work. To reduce your exposure to these chemicals: work in a well ventilated area, and work with approved safety equipment, such as those dust masks that are specially designed to filter out microscopic particles. *(California Health & Safety Code 25249.5, et seq.)*
47.  **WARNING!** People with pacemakers should consult their physician(s) before using this product. Electromagnetic fields in close proximity to a heart pacemaker could cause interference to or failure of the pacemaker. In addition, people with pacemakers should adhere to the following:
 - A. Avoid operating this product alone.
 - B. Do not use this product with the Power Switch locked on.
 - C. Be certain that this product is properly grounded. A ground fault interrupt (GFCI) system is also a good precaution. This inexpensive device is a good safety measure because it prevents a sustained electrical shock.
 - D. Properly maintain and inspect this product before use to avoid electric shock.

27. **WARNING!** The warnings, precautions, and instructions discussed in this manual cannot cover all possible conditions and situations that may occur. The operator must understand that common sense and caution are factors which cannot be built into this product, but must be supplied by the operator.

ASSEMBLY AND OPERATING INSTRUCTIONS

NOTE: For additional references to the parts listed in the following pages, refer to the **Assembly Diagram on page 20.**

To Install A Sanding Belt:

1. **WARNING!** Prior to performing any assembly procedures, make sure the **Power Switch (30)** is in its “OFF” position and the **Power Cord (29)** of the **Sander** is unplugged from its electrical outlet.
2. Push the **Handle (36)** forward, and slide the **Sanding Belt (45)** onto the **Drive Roller (5)** and **Idler Roller (41)**. Make sure the **Sanding Belt** is centered on both **Rollers**. Then, slide the **Handle** back to its original position. **IMPORTANT:** To avoid damage to the machine, make sure there is a 1/16” gap between the **Sanding Belt** and the **Work Support (33)** (**See Figures E and F.**)
3. With the **Sanding Belt (45)** installed, rotate the **Sanding Belt** a few revolutions by hand. If the tracking of the **Sanding Belt** needs adjusting, turn the **Adjusting Knob (39)** *clockwise* to make the **Sanding Belt** track more to the *right*. To make the **Sanding Belt** track more to the *left*, turn the **Adjusting Knob** *counterclockwise*. (**See Figures E and F.**)

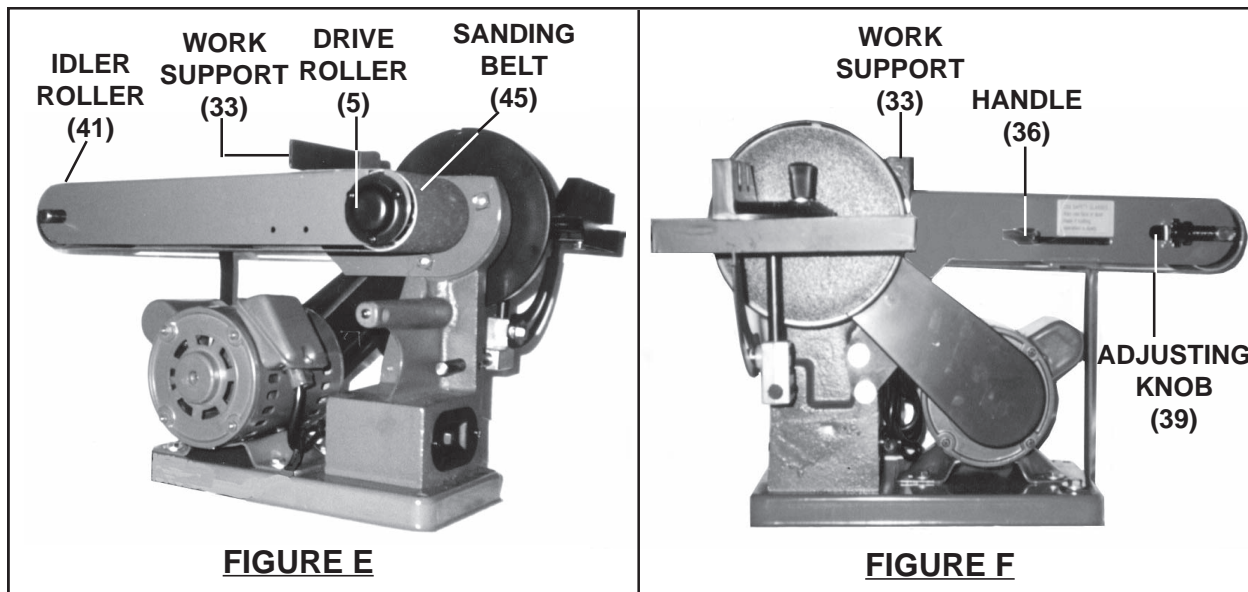

To Install A Sanding Disc:

1.  **WARNING!** Prior to performing any assembly procedures, make sure the Power Switch (30) is in its “OFF” position and the Power Cord (29) of the Sander is unplugged from its electrical outlet.
2. Check to make sure the Disc (11) is free of dirt, oil, and other debris. **(See Figure G.)**
3. Remove the paper backing on the adhesive Sanding Disc (12), and stick the Sanding Disc firmly and evenly on the Disc (11). **IMPORTANT:** To avoid damage to the machine, make sure there is a **1/16”** gap between the Sanding Disc and the Work Table (13). **(See Figure G.)**

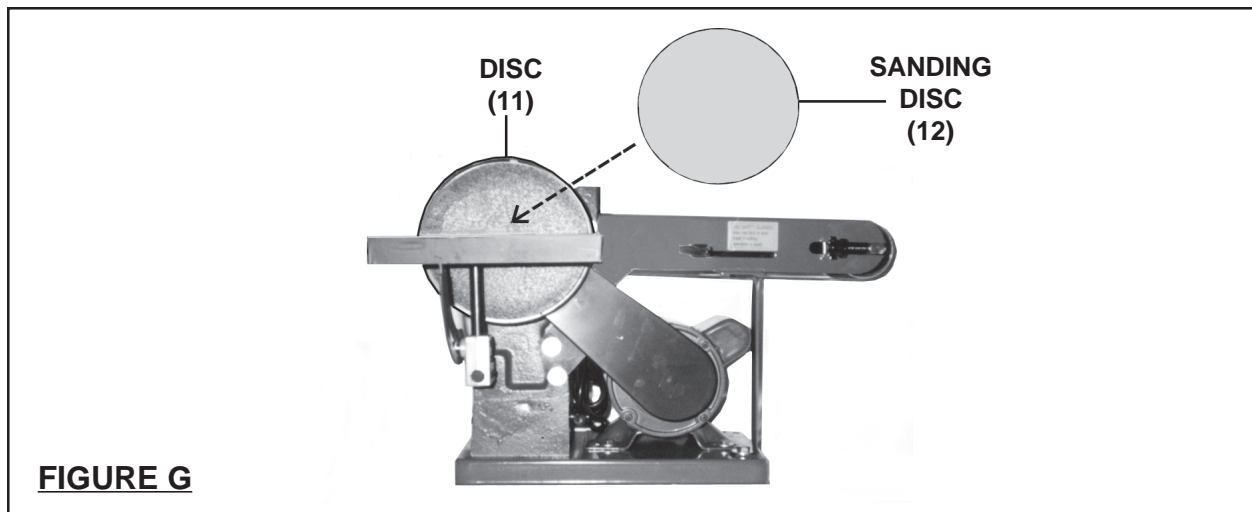

To Adjust The Angle Of The Work Table:

1.  **WARNING!** Prior to performing any assembly procedures, make sure the Power Switch (30) is in its “OFF” position and the Power Cord (29) of the Sander is unplugged from its electrical outlet.
2. The angle of the Work Table (13) may be adjusted from 0 to 45 degrees to allow for bevel sanding. **(See Figure H, next page.)**
3. To adjust the angle, slightly loosen the Lock Screw (15). **(See Figure H.)**
4. Observe the gauge on the Angle Plate (14). Raise or lower the Work Table (13) to set the Work Table to the desired angle. Then, retighten the Lock Screw (15) to lock the Work Table in place. **(See Figure H.)**

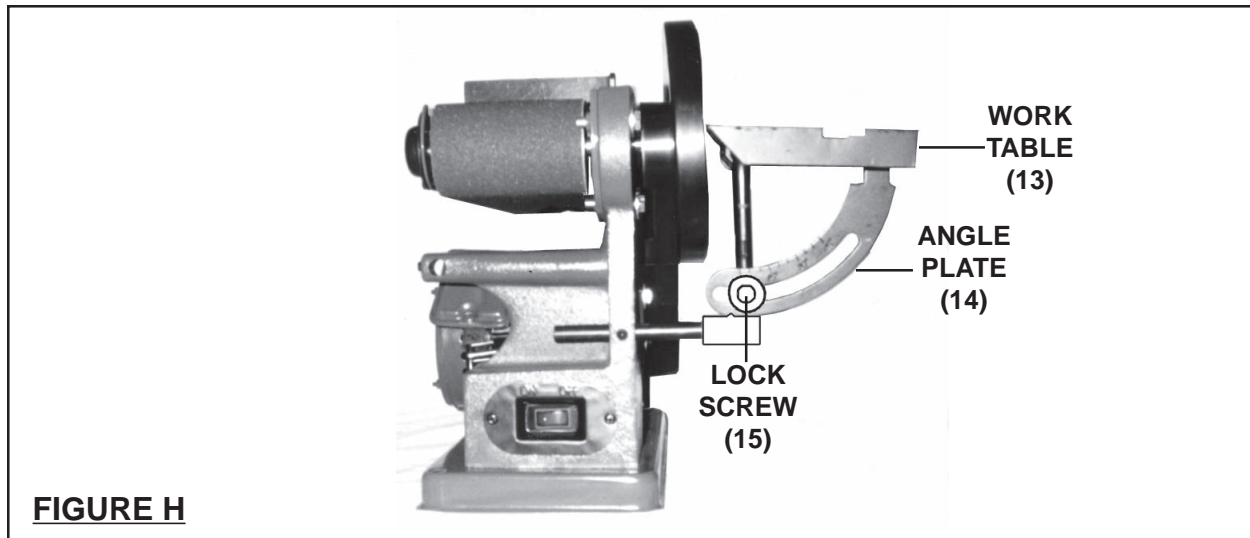

To Adjust The Angle Of The Miter Guide:

1. The angle of the Miter Guide (21) may be adjusted to the right 0 to 45 degrees and to the left 0 to 45 degrees. **(See Figure I.)**
2. To adjust the angle of the Miter Guide (21), slightly loosen the Miter Guide Knob (22). **(See Figure I.)**
3. Observe the gauge on the Miter Guide (21). Move the Miter Guide to the right or left until the desired angle is indicated on the gauge. Then, retighten the Miter Guide Knob (22) to lock the Miter Guide in place. **(See Figure I.)**

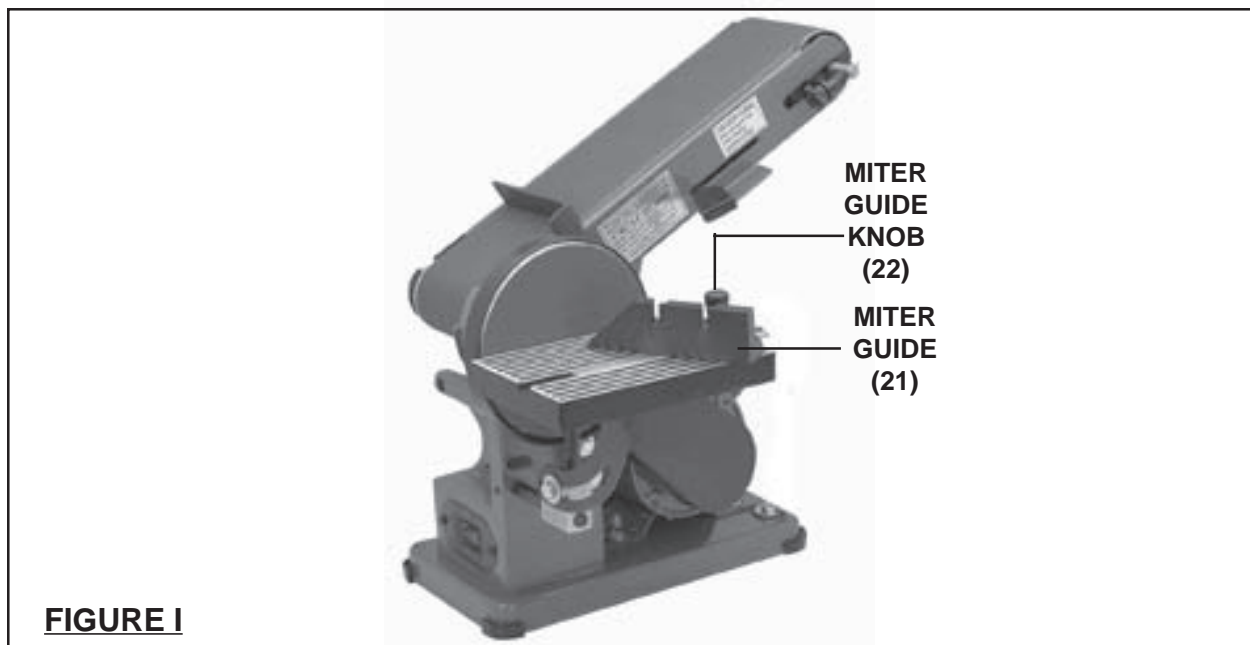

To Adjust For Vertical Sanding:

1. Slightly loosen the Lock Screw (20). **(See Figure J.)**
2. Raise the Belt Frame vertically to the desired position. Then, retighten the Lock Screw (20) to lock the Belt Frame in place. **(See Figure J.)**

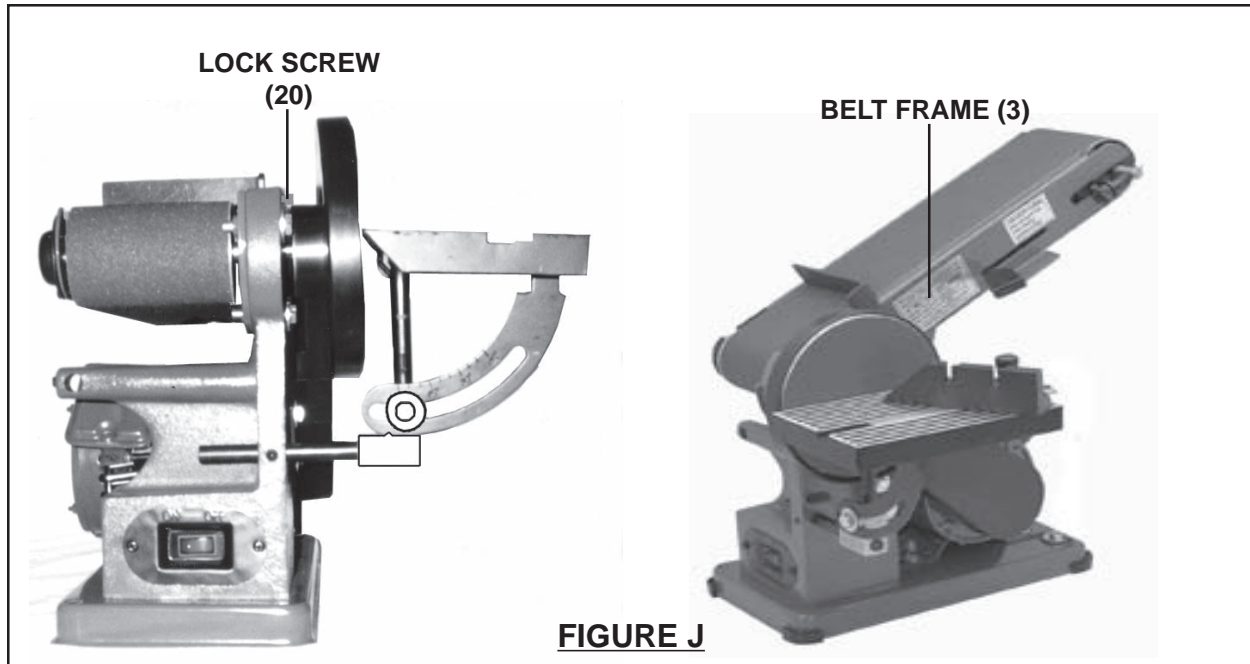

To Perform Horizontal Sanding With The Sanding Belt:

1. **⚠ CAUTION!** Before each use, inspect the condition of the Sanding Belt (45). Look for tearing, excessive wear, or other damage to the Sanding Belt. Never use a Sanding Belt that is damaged.
2. Plug the Power Cord (29) into the nearest 110 volt, grounded, electrical outlet.
3. Turn the Power Switch (30) to its “ON” position, and allow the Sanding Belt (45) to spin at full speed before feeding the workpiece into the Belt. **(See Figure K, next page.)**
4. Hold the workpiece firmly with both hands, and carefully set the workpiece flat and level upon the spinning Sanding Belt (45) and against the Work Support (33). **(See Figure K.)**
5. Apply moderate downward pressure on the workpiece, allowing the Sanding Belt (45) to cut without being forced. **(See Figure K.)**

6. Once the sanding procedure is completed, remove the workpiece from the Sanding Belt (45). Turn the Power Switch (30) to its "OFF" position, and unplug the machine from its electrical outlet. **(See Figure K.)**

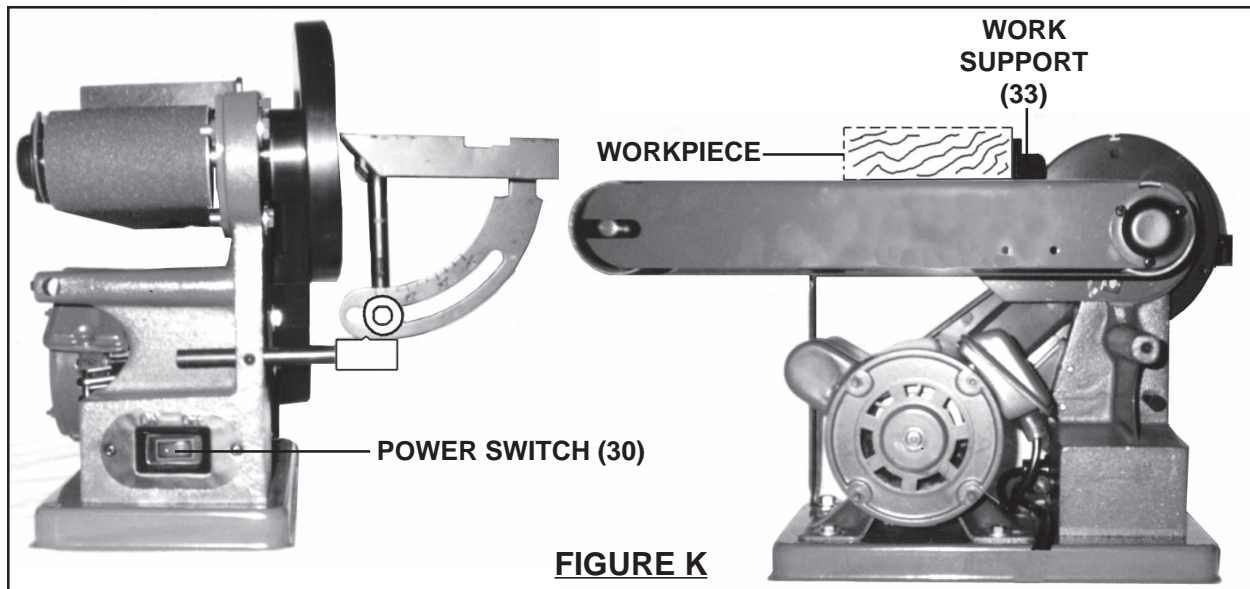

To Perform Vertical Sanding With The Sanding Belt:

1. **CAUTION!** Before each use, inspect the condition of the Sanding Belt (45). Look for tearing, excessive wear, or other damage to the Sanding Belt. Never use a Sanding Belt that is damaged.
2. Slightly loosen the Lock Screw (20). **(See Figure J.)**
3. Raise the Belt Frame vertically to the desired position. Then, retighten the Lock Screw (20) to lock the Belt Frame in place. **(See Figure J.)**
4. Plug the Power Cord (29) into the nearest 110 volt, grounded, electrical outlet.
5. Turn the Power Switch (30) to its "ON" position, and allow the Sanding Belt (45) to spin at full speed before feeding the workpiece into the Belt. **(See Figure L, next page.)**
6. Hold the workpiece firmly with both hands, and carefully set the workpiece flat and level upon the spinning Sanding Belt (45) and against the Work Support (33). **(See Figure L.)**
7. Apply moderate downward pressure on the workpiece, allowing the Sanding Belt (45) to cut without being forced. **(See Figure L.)**

8. Once the sanding procedure is completed, remove the workpiece from the Sanding Belt (45). Turn the Power Switch (30) to its "OFF" position, and unplug the machine from its electrical outlet. **(See Figure L.)**

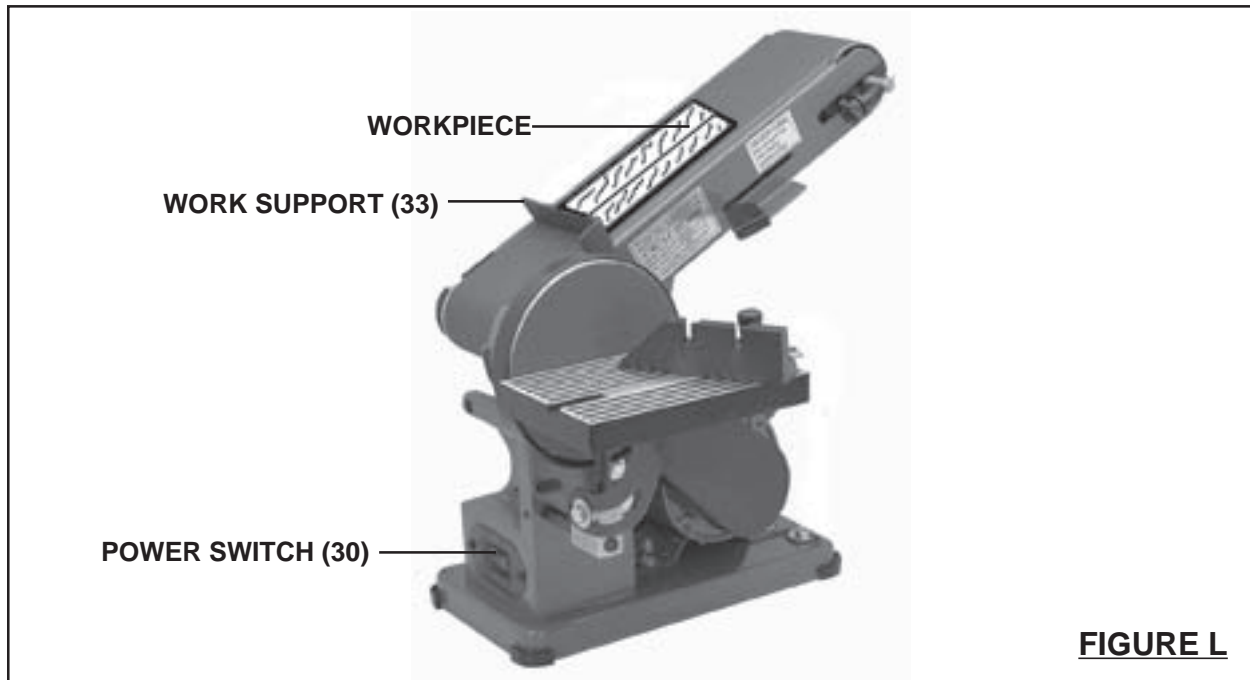

To Perform Horizontal Sanding With The Sanding Disc:

1.  **CAUTION!** Before each use, inspect the condition of the Sanding Disc (12). Look for tearing, excessive wear, or other damage to the Sanding Disc. Never use a Sanding Disc that is damaged.
2. **NOTE:** The Sanding Disc (12) is typically used for *smaller* workpieces. **(See Figure M, next page.)**
3. If necessary, adjust the angle of the Miter Guide (21). Make sure to retighten the Miter Guide Knob (22) to lock the Miter Guide in place. **(See Figure I.)**
4. Plug the Power Cord (29) into the nearest 110 volt, grounded, electrical outlet.
5. Turn the Power Switch (30) to its "ON" position, and allow the Sanding Disc (12) to spin at full speed before feeding the workpiece into the Disc. **(See Figure M.)**
6. Carefully set the workpiece flat and level upon the spinning Work Table (13) and against the Miter Guide (21). **(See Figure M.)**

7. Hold the workpiece firmly with one hand and the Miter Guide (21) with the other hand. Gradually push the workpiece into the Sanding Disc (12), allowing the Sanding Disc to cut without being forced. **(See Figure M.)**
8. Once the sanding procedure is completed, remove the workpiece from the Sanding Disc (12). Turn the Power Switch (30) to its "OFF" position, and unplug the machine from its electrical outlet. **(See Figure M.)**

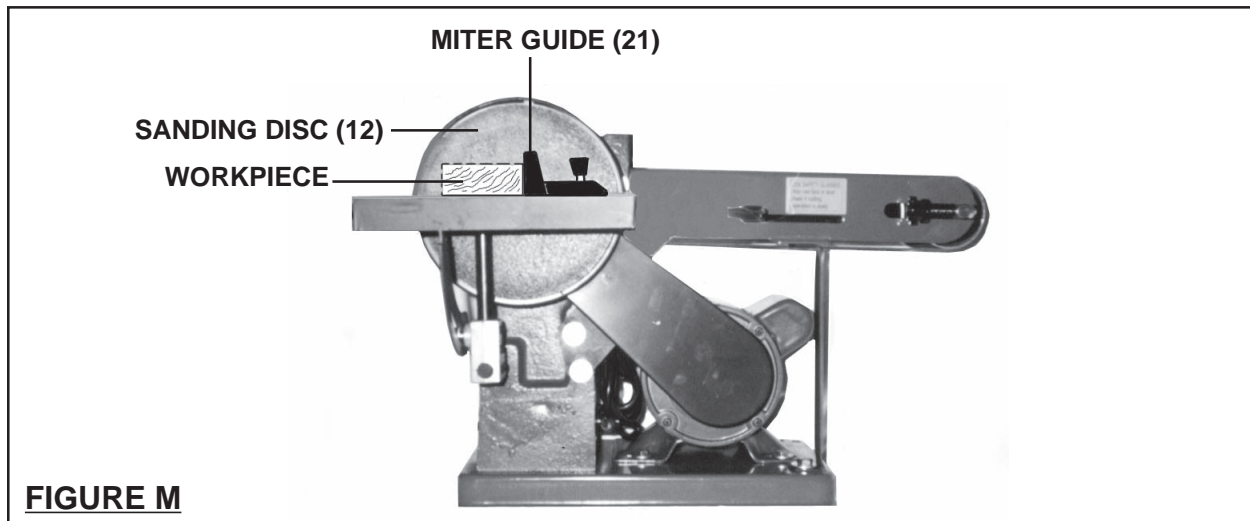



FIGURE M

INSPECTION, MAINTENANCE, AND CLEANING

1.  **WARNING!** Make sure the Power Switch (30) is in its "OFF" position and the Power Cord (29) is unplugged from its electrical outlet before performing any inspection, maintenance, or cleaning procedures.
2. **Before each use**, inspect the general condition of the Sander. Check for damaged electrical wiring, loose connections, broken parts, loose Sanding Disc (12) and Sanding Belt (45), and any other condition that may affect its safe operation. If abnormal noise or vibration occurs, have the problem corrected before further use. **Do not use damaged equipment.**
3. **Daily:** Sanding Discs (12) and Sanding Belts (45) must be sharp and clean to perform properly. Depending on materials sanded and frequency of use, Sanding Discs and Sanding Belts become clogged with wood particles and dull. Dull Sanding Discs and Sanding Belts rub the workpiece rather than cut, which results in increase friction, higher temperatures, and burned workpieces. As often as possible, check the condition of the Sanding Disc and, if necessary, replace a worn Sanding Disc with a new 6" diameter Sanding Disc. If necessary, replace a worn Sanding Belt with a new 4" x 36" Sanding Belt.

4. **Daily:** With a soft brush, vacuum, or compressed air remove all sawdust and debris from the Sander. Do not immerse any part of the Sander in liquid. Then, use a premium quality machine oil to lubricate all moving parts.
5. **When storing,** make sure to store the Sander in a safe, clean, and dry location.

<p style="text-align: center;">PLEASE READ THE FOLLOWING CAREFULLY</p>

THE MANUFACTURER AND/OR DISTRIBUTOR HAS PROVIDED THE PARTS LIST AND ASSEMBLY DIAGRAM IN THIS MANUAL AS A REFERENCE TOOL ONLY. NEITHER THE MANUFACTURER OR DISTRIBUTOR MAKES ANY REPRESENTATION OR WARRANTY OF ANY KIND TO THE BUYER THAT HE OR SHE IS QUALIFIED TO MAKE ANY REPAIRS TO THE PRODUCT, OR THAT HE OR SHE IS QUALIFIED TO REPLACE ANY PARTS OF THE PRODUCT. IN FACT, THE MANUFACTURER AND/OR DISTRIBUTOR EXPRESSLY STATES THAT ALL REPAIRS AND PARTS REPLACEMENTS SHOULD BE UNDERTAKEN BY CERTIFIED AND LICENSED TECHNICIANS, AND NOT BY THE BUYER. THE BUYER ASSUMES ALL RISK AND LIABILITY ARISING OUT OF HIS OR HER REPAIRS TO THE ORIGINAL PRODUCT OR REPLACEMENT PARTS THERETO, OR ARISING OUT OF HIS OR HER INSTALLATION OF REPLACEMENT PARTS THERETO.

PARTS LIST

Part #	Description	Qty.	Part #	Description	Qty.
1	Base	1	33	Work Support	1
2	Pivot Bracket	1	34	Pull Rod	1
3	Belt Frame	1	35	Push Back Spring	1
4	Main Shaft	1	36	Handle	1
5	Drive Roller	1	37	Handle Socket	1
6	Ball Bearing	2	38	Block Plate	1
7	Bearing Cover	1	39	Adjusting Knob	1
8	Bearing Cover (Steel)	1	40	Adjusting Spring	1
9	Drive Pulley	1	41	Idler Roller	1
10	Belt Cover	1	42	Idler Shaft	1
11	Disc (6")	1	43	Ball Bearing	2
12	Sanding Disc (6")	1	44	"C" Ring	2
13	Work Table	1	45	Sanding Belt (4" x 36")	1
14	Angle Plate	1	46	Round Head Set Screw	2
15	Lock Screw	1	47	Round Head Set Screw	9
16	Table Bracket	1	48	Round Head Set Screw	1
17	Point	1	49	Hex Head Screw	2
18	Set Block	1	50	Hex Head Screw	4
19	Rod	1	51	Hex Head Screw	5
20	Lock Screw	1	52	Hex Head Screw	2
21	Miter Guide	1	53	Socket Cap Head Screw	2
22	Miter Guide Knob	1	54	Socket Set Screw	2
23	Pin	1	55	Socket Set Screw	1
24	Miter Bar	1	56	Socket Set Screw	2
25	Motor	1	57	Hex Nut	2
26	Motor Pulley	1	58	Hex Nut	8
27	Belt	1	59	Hex Nut	2
28	Plane Stop	1	60	Spring Washer	8
29	Power Cord	1	61	Washer	11
30	Power Switch	1	62	Washer	3
-----	-----	-----	63	Hex Key	1
32	Plastic Joint				

NOTE: Some parts are listed and shown for illustration purposes only, and are not available individually as replacement parts.

RAM ATIC

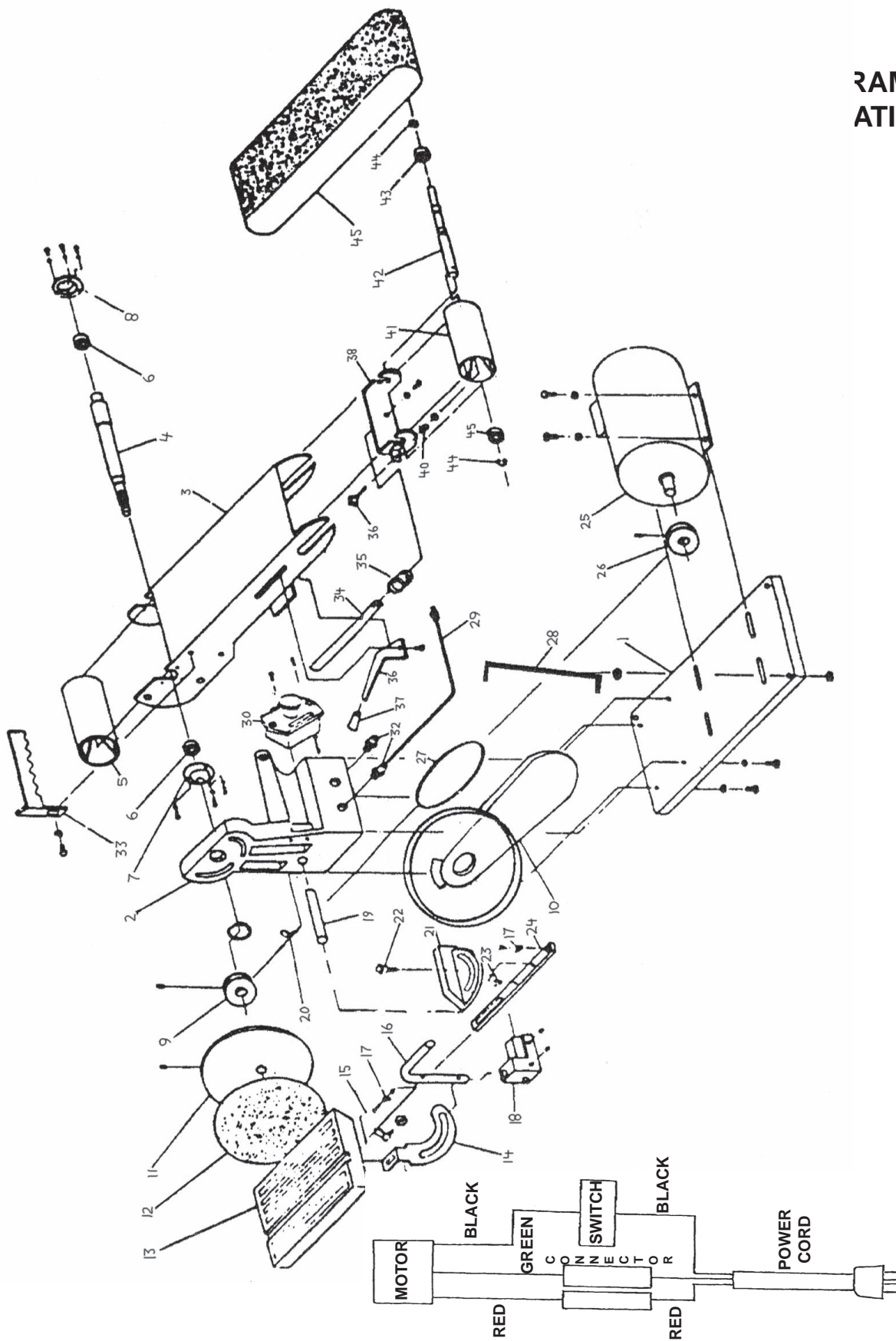

NOTE: Some parts are listed and shown for illustration purposes only, and are not available individually as replacement parts.

Free Manuals Download Website

<http://myh66.com>

<http://usermanuals.us>

<http://www.somanuals.com>

<http://www.4manuals.cc>

<http://www.manual-lib.com>

<http://www.404manual.com>

<http://www.luxmanual.com>

<http://aubethermostatmanual.com>

Golf course search by state

<http://golfingnear.com>

Email search by domain

<http://emailbydomain.com>

Auto manuals search

<http://auto.somanuals.com>

TV manuals search

<http://tv.somanuals.com>