

# BUCK HORN WAGON WOODEN MODEL

**Model**09141

## ASSEMBLY INSTRUCTIONS

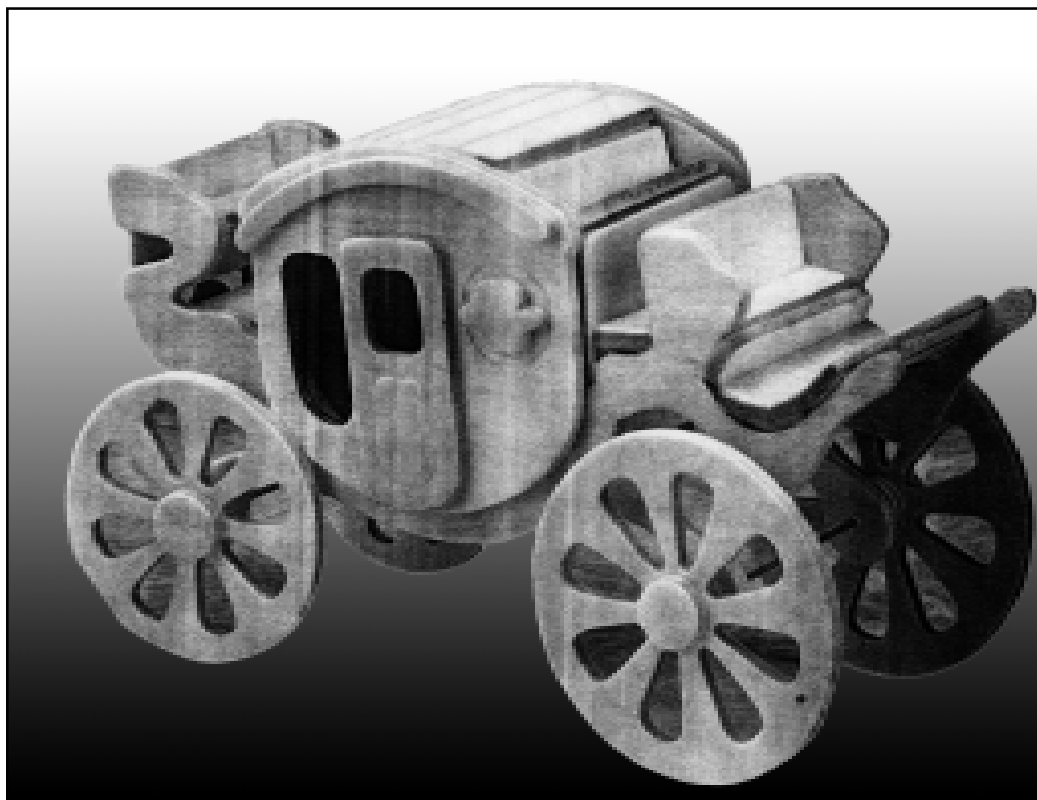

3491 Mission Oaks Blvd., Camarillo, CA 93011  
Visit our Web site at <http://www.harborfreight.com>

Copyright © 2003 by Harbor Freight Tools®. All rights reserved. No portion of this manual or any artwork contained herein may be reproduced in any shape or form without the express written consent of Harbor Freight Tools.

**For technical questions please call 1-800-444-3353**

## SPECIFICATIONS

ITEM	DESCRIPTION
Overall Dimensions	6-1/2" Long X 4" Wide X 2-7/8" High
Templates Dimension	9" Long X 7-1/4" Wide (2X)
Finish	Natural Pressed Core-Wood
Materials	Pressed/Template Scored Core-Wood
Net Weight	5.2 Ounces
Age Appropriate	6 years and older

## SAVE THIS MANUAL

You will need the manual for the safety warnings and precautions, assembly instructions, operating and maintenance procedures, parts list and diagram. Keep your invoice with this manual. Write the invoice number on the inside of the front cover. Keep the manual and invoice in a safe and dry place for future reference.

## SAFETY WARNINGS AND PRECAUTIONS

1. **KEEP PRODUCT USAGE AREA CLEAN.** Cluttered areas invite injuries.
2. **KEEP YOUNG CHILDREN AWAY FROM PRODUCT USAGE AREA.** This product has small parts that could pose a choking hazard. Allow children to handle this product only with supervision. Be aware of the dangers of glue sniffing or swallowing small parts.
3. **CHECK FOR DAMAGED PARTS.** Check for damaged parts and any other conditions that may affect it's construction.
4. **DETACH PARTS FROM BASE PLATE CAREFULLY.** Pieces are to be pushed out with thumb. These are delicate pieces. If handled too roughly, they will be damaged and construction of model impossible to complete.
5. **AVOID SHARP EDGES WHEN ASSEMBLING.** If not careful, splinters may lodge under fingernails when assembling.
6. **THIS IS NOT A TOY** but a model to be constructed according to these directions. Putting the model together will help develop coordination and problem-solving skills for children ages six and older. Children should be supervised when model is being built.

# ASSEMBLY INSTRUCTIONS

1. Check the part numbers on the templates below to the drawing on Page 4. Mark each with the corresponding number with a pencil to help organize. Lay out in numeric order on a smooth surface after pressing out each piece with your thumb. (See Figure A-B)

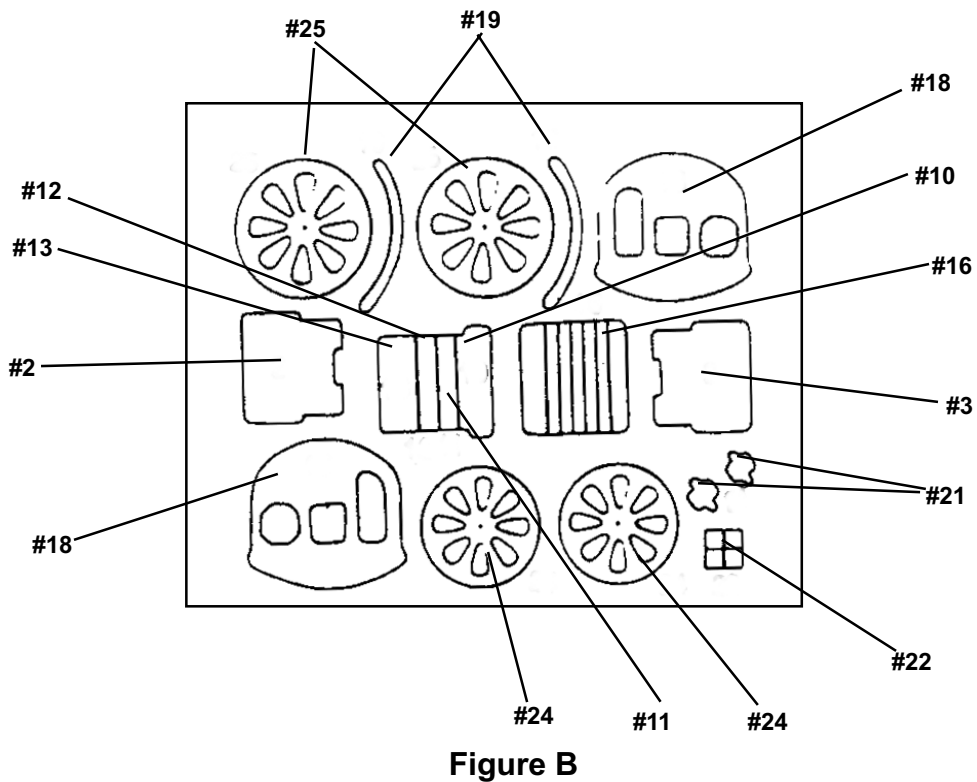
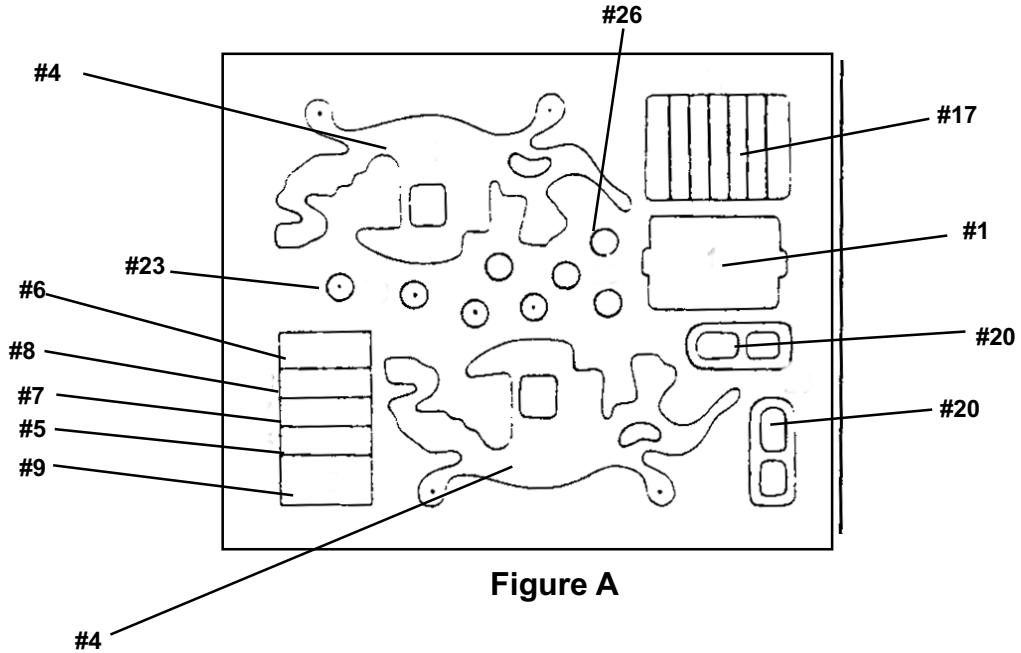

2. Smooth the edges of the punched out pieces with sand paper. Begin putting together by using the drawing below as a guide. Use glue on the portions shown in "black". See arrows in Figure D.
3. Use Scotch Tape® on the backside to hold round or non-flat pieces together.
4. A rubber band can be used to hold assembled pieces until glue has dried. Clean the edges or surfaces of the Wagon with a wet cloth to remove wet glue or unsightly smudges.
5. Rod "A" passes through Wheels (#23, #24, #26 & #4) front and rear of wagon.
6. When assembly is completed, you can finish the Wagon with paint, colored markers or crayons using your creativity.

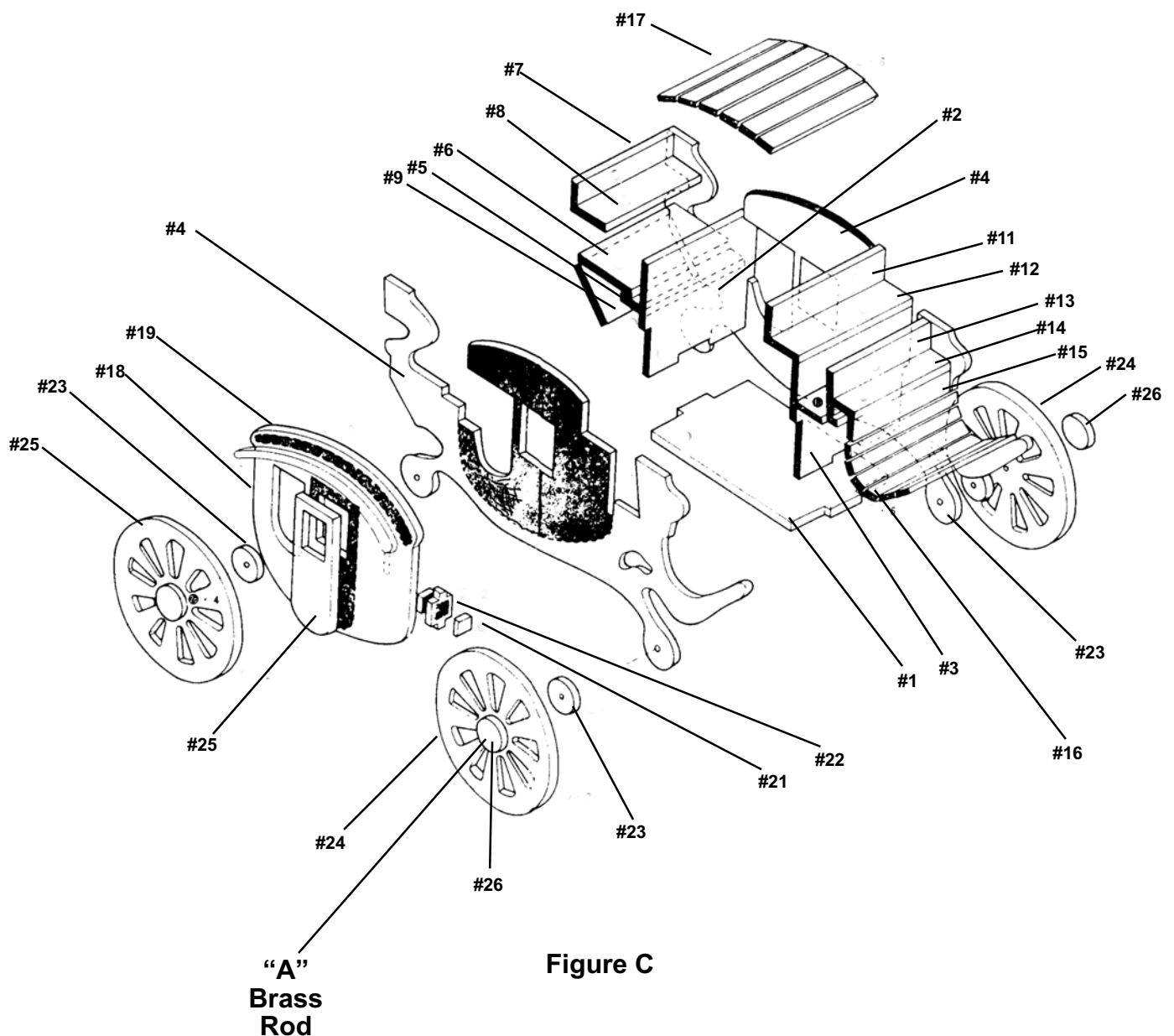

**Figure C**

## PARTS LIST

PART #	DESCRIPTION	QTY
1	Templates-Scored Core-Wood	2
2	Glue (White)	1
3	Sand Paper (2" X 2")	1
A	Axle Rod (not shown)	2

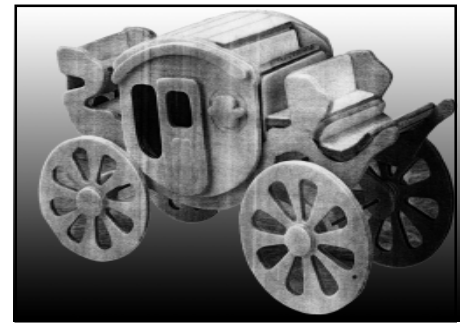
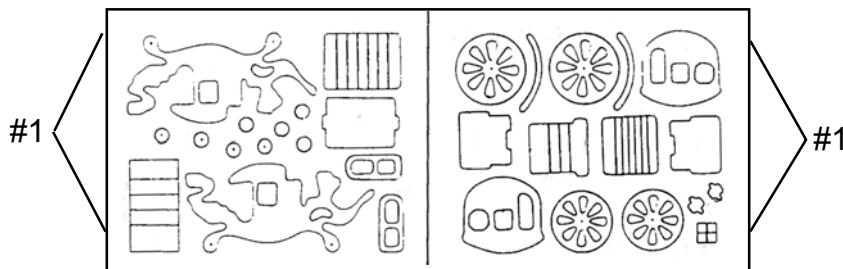

## MAINTENANCE

1. For better and safer performance, keep all parts of this product clean and dry.
2. Periodically check to see that all hardware is in place.

### **PLEASE READ THE FOLLOWING CAREFULLY**

THE MANUFACTURER AND/OR DISTRIBUTOR HAS PROVIDED THE PARTS DIAGRAM IN THIS MANUAL AS A REFERENCE TOOL ONLY. NEITHER THE MANUFACTURER NOR DISTRIBUTOR MAKES ANY REPRESENTATION OR WARRANTY OF ANY KIND TO THE BUYER THAT HE OR SHE IS QUALIFIED TO MAKE ANY REPAIRS TO THE PRODUCT OR THAT HE OR SHE IS QUALIFIED TO REPLACE ANY PARTS OF THE PRODUCT. IN FACT, THE MANUFACTURER AND/OR DISTRIBUTOR EXPRESSLY STATES THAT ALL REPAIRS AND PARTS REPLACEMENTS SHOULD BE UNDERTAKEN BY CERTIFIED AND LICENSED TECHNICIANS AND NOT BY THE BUYER. THE BUYER ASSUMES ALL RISK AND LIABILITY ARISING OUT OF HIS OR HER REPAIRS TO THE ORIGINAL PRODUCT OR REPLACEMENT PARTS THERETO, OR ARISING OUT OF HIS OR HER INSTALLATION OF REPLACEMENT PARTS THERETO.

## Free Manuals Download Website

<http://myh66.com>

<http://usermanuals.us>

<http://www.somanuals.com>

<http://www.4manuals.cc>

<http://www.manual-lib.com>

<http://www.404manual.com>

<http://www.luxmanual.com>

<http://aubethermostatmanual.com>

Golf course search by state

<http://golfingnear.com>

Email search by domain

<http://emailbydomain.com>

Auto manuals search

<http://auto.somanuals.com>

TV manuals search

<http://tv.somanuals.com>