

CENTRAL PNEUMATIC®

AIR PIN NAILER

Model 93656

ASSEMBLY and OPERATING INSTRUCTIONS



3491 Mission Oaks Blvd., Camarillo, CA 93011

Visit our Web site at <http://www.harborfreight.com>

**TO PREVENT SERIOUS INJURY,
READ AND UNDERSTAND ALL WARNINGS
AND INSTRUCTIONS BEFORE USE.**

Copyright© 2005 by Harbor Freight Tools®. All rights reserved. No portion of this manual or any artwork contained herein may be reproduced in any shape or form without the express written consent of Harbor Freight Tools.

For technical questions and replacement parts, please call 1-800-444-3353

Specifications

Pin Size	23 Gauge, 1/2" to 1" long, Headless pins
Magazine Capacity	100
Operating PSI	60-100 PSI
Air Inlet Size	1/4" NPT Male
Safety Feature	Single Sequential Safety Trip Mechanism
Accessories	Two Hex Wrenches, Lubricating Oil, 1,500 Fasteners: 500 each - 5/8", 3/4", & 1" Pins

Save This Manual

You will need the manual for the safety warnings and precautions, assembly instructions, operating and maintenance procedures, parts list and diagram. Keep your invoice with this manual. Write the invoice number on the inside of the front cover. Keep the manual and invoice in a safe and dry place for future reference.

Safety Warnings and Precautions



WARNING: When using tool, basic safety precautions should always be followed to reduce the risk of personal injury and damage to equipment.

Read all instructions before using this tool!

1. **Keep work area clean.** Cluttered areas invite injuries.
2. **Observe work area conditions.** Do not use machines or power tools in damp or wet locations. Do not expose to rain. Keep work area well lit. Do not use electrically powered tools in the presence of flammable gases or liquids.
3. **Keep children away.** Children must never be allowed in the work area. Do not let them handle machines, tools, extension cords, or air hoses.
4. **Store idle equipment.** When not in use, tools must be stored in a dry location to inhibit rust. Always lock up tools and keep out of reach of children.
5. **Use the right tool for the job.** Do not attempt to force a small tool or attachment to do the work of a larger industrial tool. There are certain applications for which this tool was designed. It will do the job better and more safely at the rate for which it was intended. Do not modify this tool and do not use this tool for a purpose for which it was not intended.
6. **Dress properly.** Do not wear loose clothing or jewelry as they can be caught in moving parts. Protective, electrically nonconductive clothes and nonskid footwear are recommended when working. Wear restrictive hair covering to contain long hair.
7. **Do not overreach.** Keep proper footing and balance at all times. Do not reach over or across running machines or air hoses.
8. **Stay within air pressure capacity.** Never operate the Nailer above 90 PSI.
9. **Hold tool away from head and body.** During operation the Nailer may kick back causing injury.

10.  **Use eye and ear protection.** Always wear ANSI approved impact safety goggles and appropriate hearing protection. Wear a full face shield if you are producing metal filings or wood chips. Wear an ANSI approved dust mask or respirator when working around metal, wood, and chemical dusts and mists. Other people in the work area must also wear ANSI approved impact safety goggles.
11. **Maintain tools with care.** Keep tools clean for better and safer performance. Follow instructions for lubricating and changing accessories. Inspect tool cords and air hoses periodically and, if damaged, have them repaired by an authorized technician. The handle must be kept clean, dry, and free from oil and grease at all times. Do not operate a tool if any portion of the tool's operating controls are inoperable, disconnected, altered or not working properly.
12. **Disconnect Air Hose and release any built-up air pressure.** Never service the Nailer, clear jams, or disassemble with the air hose attached. Always release any built-up air even after disconnecting hose. Disconnect the Nailer when not in use.
13. **Remove adjusting keys and wrenches.** Check that keys and adjusting wrenches are removed from the tool or machine work surface before attaching to an air source.
14. **Avoid unintentional starting.** Be sure the trigger is in the Off position when not in use and before plugging in. Do not carry any tool with your finger on the trigger, whether it is attached to an air source or not. Do not point the tool towards yourself or anyone whether it contains fasteners or not.
15. **Stay alert.** Watch what you are doing, use common sense. Do not operate any tool when you are tired.
16. **Check for damaged parts.** Before using any tool, any part that appears damaged should be carefully checked to determine that it will operate properly and perform its intended function. Check for alignment and binding of moving parts; any broken parts or mounting fixtures; and any other condition that may affect proper operation. Any part that is damaged should be properly repaired or replaced by a qualified technician. Do not use the tool if the trigger does not operate properly.
17. **Guard against electric shock.** Prevent body contact with grounded surfaces such as pipes, radiators, ranges, and refrigerator enclosures.
18. **Replacement parts and accessories.** This product is to be repaired and serviced only by a qualified technician. When this product is serviced, only identical replacement parts should be used. Use of any other parts will void the warranty. Only use accessories intended for use with this tool. Approved accessories are available from Harbor Freight Tools.
19. **Do not operate tool if under the influence of alcohol or drugs.** Read warning labels if taking prescription medicine to determine if your judgement or reflexes are impaired while taking drugs. If there is any doubt, do not operate the tool.
20. **Use proper size and type extension cord.** If an extension cord is required, it must be of the proper size and type to supply the correct current to the compressor without heating up. Otherwise, the extension cord could melt and catch fire, or cause electrical damage to the tool. Check your air compressor's manual for the appropriate size cord. It is also possible that the use of an extension cord may cause your circuit breaker to trip or your

panel fuse to break. If this happens, either use the compressor without an extension cord or find a larger amperage circuit to use.

21. **Maintenance.** The maintenance outlined in the maintenance section should be performed regularly. For your safety, this product should be serviced or repaired regularly only by a qualified technician.
22. **Compressed air only.** Use clean, dry regulated, compressed air at 90 PSI. Never use oxygen, carbon dioxide, combustible gases, or any other bottled gas as a power source for this tool.
23.  **Do not load pins with the trigger or safety depressed.** Unintentional firing may occur. Do not load nails when the air hose is connected to the tool. Always assume that the tool contains fasteners.
24. **Disconnect air supply before loading Nailer.** Before reloading (or making any adjustments to) the Nailer make sure that the compressed air is disconnected.
25. **Fire fasteners into an appropriate work surface only.** Do not attempt to fire fasteners into surfaces too hard to penetrate. Do not drive fasteners on top of other fasteners, or at too steep of an angle. Fasteners can ricochet causing personal injury. Never fire the Nailer into the air, or point it toward yourself or another person. Always wear ANSI approved safety goggles during use, maintenance, and reloading.
26. **Do not fire fasteners too close to the edge of a workpiece.** They may split the workpiece and fly free, causing personal injury.
27. **Take caution as some woods contain preservatives such as copper chromium arsenate (CCA) which can be toxic.** When stapling or nailing these materials extra care should be taken to avoid inhalation and minimize skin contact.

WARNING: Some dust created by power sanding, sawing, grinding, drilling, and other construction activities, contain chemicals known [to the State of California] to cause cancer, birth defects or other reproductive harm.

Some examples of these chemicals are:

- **Lead from lead-based paints**
- **Crystalline silica from bricks and cement or other masonry products**
- **Arsenic and chromium from chemically treated lumber**

(California Health & Safety Code § 25249.5, et seq.)

28. **Transport Nailer safely.** Always disconnect air supply when moving the tool in the workplace. Carry the tool by the handle and avoid contact with the trigger.

Note: Performance of the compressor (if powered by line voltage) may vary depending on variations in local line voltage. Extension cord usage may also affect tool performance.

Warning: The warnings, cautions, and instructions discussed in this instruction manual cannot cover all possible conditions and situations that may occur. It must be understood by the operator that common sense and caution are factors which cannot be built into this product, but must be supplied by the operator.

Unpacking

When unpacking, check to make sure the parts listed on page 9 are included. If any parts are missing or broken, please call Harbor Freight Tools at the number on the cover of this manual as soon as possible.

Operation

For best service, you should incorporate an oiler, regulator, and inline filter, as shown in the diagram below. Hoses, couplers, oilers, regulators, and filters are all available at Harbor Freight Tools.

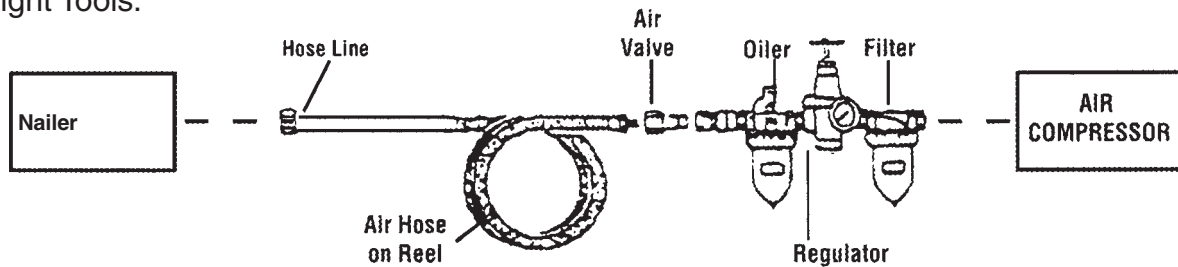

Recommended Air Line Components

Note: To connect this tool, we recommend a quick coupler/adaptor (not included). Coupler/adapters are available at Harbor Freight Tools. If an automatic oiler is not used, put 3-5 drops of pneumatic tool oil in the **Air Inlet (22)** before each use.

Testing the Single Sequential Safety Trip Mechanism

Warning: Even though the nailer should be empty during this procedure, **ALWAYS** point the nailer at a piece of scrap wood when testing.

1. Make sure the tool is disconnected from the power supply.
2. Completely empty the magazine of pins.
3. The Nailer should not fire if the nose is not depressed against the workpiece.
4. Check that the **Trigger (42)** and the **Safety (48)** move freely, without sticking - see *Figure 1*, next page.
5. Connect the air supply to the tool at the **Air Inlet (22)** set at the recommended 60-100 PSI, and not to go over the maximum 100 PSI.
6. Test the tool by depressing the **Safety (48)** against the workpiece without pulling the **Trigger (42)**. **The tool must not cycle (fire)**. If it cycles (fires), stop immediately and take the tool to an authorized service technician.
7. Hold the tool away or off of the workpiece. The **Safety (48)** of the tool should return to its original position. Squeeze the **Trigger (42)**. **The tool should not cycle (fire)**. If it cycles (fires), stop immediately and take the tool to an authorized service technician.
8. Depress the **Safety (48)** against the workpiece and squeeze the **Trigger (42)**. **The tool must cycle (fire)**. Release the trigger and squeeze it again. **The tool must cycle (fire)**. With the Trigger held, carefully lift the nailer and press it against the workpiece again. **The tool must not cycle (fire)**. If it fails to act in the manner described in bold, have it repaired by a qualified service technician.

Operation (continued)

FIGURE 1

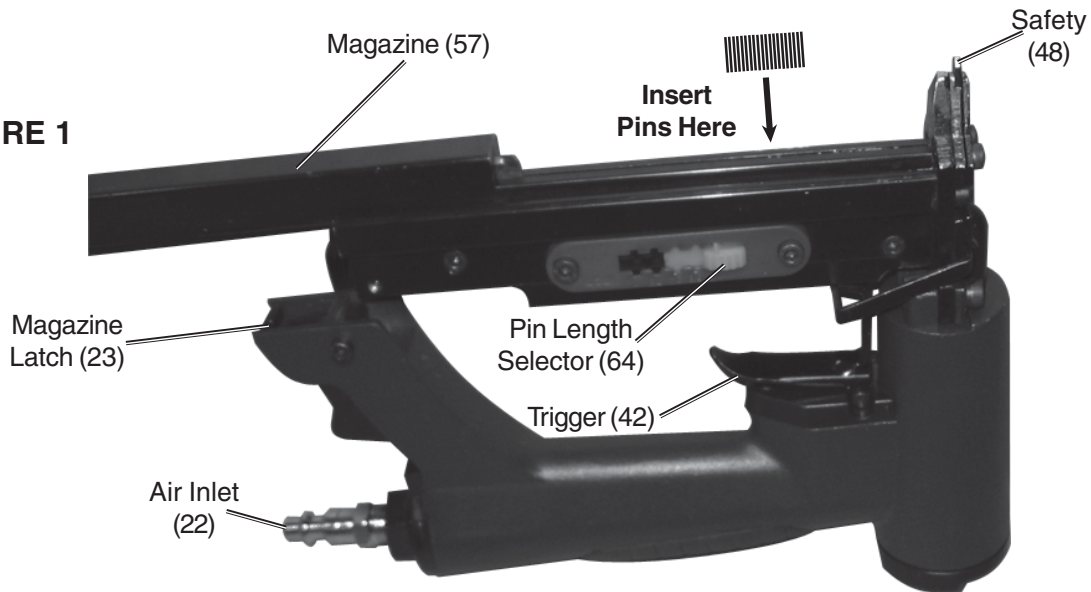

Loading Pin Nails

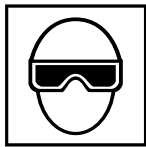

ALWAYS WEAR ANSI APPROVED IMPACT SAFETY GOGGLES WHEN RELOADING OR DOING ANY OTHER MAINTENANCE ON THIS TOOL. Other people in the work area must also wear ANSI approved impact safety goggles.

Warning! Make sure the Nailer is not attached to the air hose whenever loading the tool.

1. Press the **Magazine Latch (23)** up and slide the **Magazine (57)** back.
2. If you are using a different pin length than previously:
 - a. Remove all pins from inside the nailer.
 - b. Slide the **Pin Length Selector (64)** to the appropriate length setting. See *Figure 1*.
3. Holding the nailer upside-down, insert the pin nails into the slot noted above.
4. Close the **Magazine (57)** making sure the **Magazine Latch (23)** clicks shut. See *Figure 1*.

Operating the Nailer

1. Attach the Nailer to the air supply at the **Air Inlet (22)**. Start your compressor and check the pressure making sure it is set at the recommended 90 PSI and not to go over the maximum 90 PSI.
2. To fire, place the nose of the Nailer on the workpiece. The Nailer should not fire if the nose is not depressed. Once depressed, gently and briefly squeeze the **Trigger (42)** once. **Do not fire repeatedly.** Pins could bounce off of one another, damaging the work piece or causing PERSONAL INJURY.

Anytime *any* maintenance or repairs are done (including clearing jams), FIRST:

1. Disconnect the Nailer from the air hose.
2. Empty the **Magazine (57)** completely.
3. Attempt to fire the Nailer into a piece of scrap wood to ensure that it is disconnected and is incapable of firing any pins.
4. **Always leave the Magazine (57) open during maintenance. The Magazine is spring-loaded and may cause parts or a nail to fly out of the Nailer.**

Clearing Jams

1. Disconnect tool from air hose, empty the **Magazine (57)** of pins, release any built-up air pressure, and leave the magazine open, as explained above.
2. Hold the Nailer pointed away from you and any other people or fragile objects. Remove the **Short Cap Screw (47)** and the two longer **Cap Screws (46)** - see *Figure 2*. Remove the **Safety Cover (45)** and **Safety Spring (49)** and set them aside.
3. Remove the **Safety Guide (50)** carefully to avoid bending the **Safety (48)** - see *Figure 3*.
4. Remove the jammed pin. Pliers may be necessary to remove a stuck pin.
5. Inspect the **Driver (11)** for bends or breakage - see location in *Figure 4*. If it is damaged, do not use the tool until it is repaired by a qualified technician.
6. Lightly oil the **Driver (11)**. Replace the **Safety Guide (50)** underneath the **Safety (48)**. The **Safety (48)** should fit perfectly into the groove in the **Safety Guide (50)**. See *Figure 3*.
7. Replace the **Safety Spring (49)** onto the **Safety (48)** as in *Figure 3*. Carefully place the **Safety Cover (45)** over the **Safety** and **Spring** and attach using the **Cap Screws (46)** and the **Short Cap Screw (47)** - see *Figure 2*. Make sure that the **Short Cap Screw (47)** goes in the correct position. Make sure that the **Safety (48)** is spring loaded and moves freely, without sticking.
8. Reload the Nailer and reconnect it to the air hose.
9. Press the **Safety (48)** of the Nailer against an appropriate piece of scrap wood.
10. Test fire the Nailer several times, checking for proper operation.
11. Disconnect the Nailer, remove the pins and store it in a location out of children's reach.

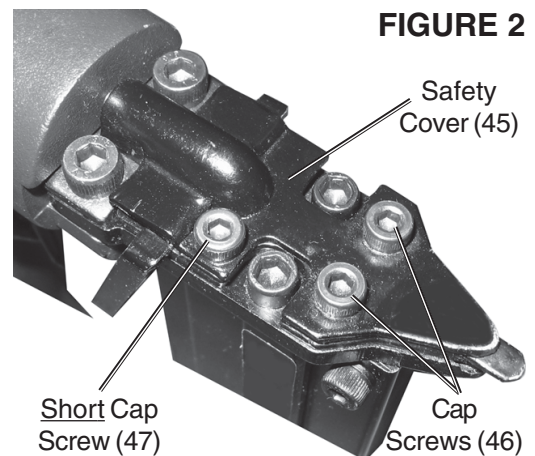

FIGURE 2

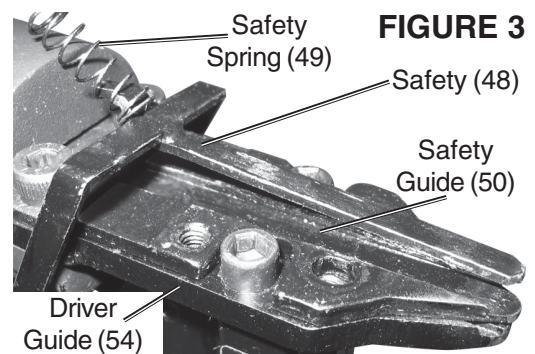

FIGURE 3

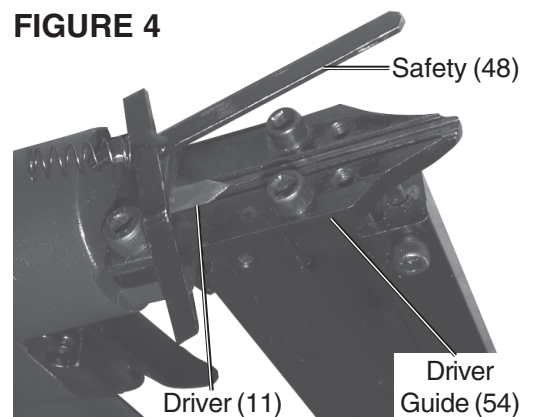

FIGURE 4

Anytime any maintenance or repairs are done, FIRST:

1. Disconnect the Nailer from the air hose.
2. Empty the **Magazine (57)** completely.
3. Attempt to fire the Nailer into a piece of scrap wood to ensure that it is disconnected and is incapable of firing any pins.
4. **Always leave the Magazine (57) open during maintenance. The Magazine is spring-loaded and may cause parts or a nail to fly out of the Nailer.**

Troubleshooting Guide

**Stop using the Brad Nailer immediately if any of the following problems occur.
Repairs and part replacements must be done only by a qualified technician.
All procedures in bold on this chart are to be attempted only by a qualified technician.**

Problem	Likely Cause	Solution
Air leaking at Trigger area.	O-Rings in Trigger Valve housing are damaged.	Replace O-Rings and check safety trip operation.
Air leaking between Housing and Nose.	Loose screws in Housing. Damaged O-Rings/Bumper (12).	Tighten screws. Replace O-Rings or Bumper (12).
Air leaking at Trigger Valve Stem.	O-Rings or Seals are damaged.	Replace O-Rings or Seals.
Air leaking between Housing and Cap.	Loose Cylinder Cap (1).	Tighten Cylinder Cap (1).
Runs slowly or has power loss.	Insufficient oil. Exhaust (18) is blocked.	Lubricate as instructed. Replace damaged parts.
Nailer skips a nail.	Worn Bumper (12) or damaged Pusher Spring. Dirt in Driver Guide (54). Inadequate airflow to Nailer. Worn or dry O-Ring on Piston. Damaged O-Ring on Trigger Valve.	Replace Bumper (12) or Pusher Spring. Clean Channels in Driver Guide (54). Check hose and compressor fittings. Replace or lubricate O-Rings. Replace O-Rings.
Nails are jammed.	Guide on driver is worn. Nails are wrong size or damaged. Magazine or Nose screws are loose. Driver (11) is damaged.	Replace Guide. Use correct, undamaged nails. Tighten screws. Replace Driver (11).
Nailer will not drive down tight.	Rounded Driver (11) slipping off nail crown. Lack of air pressure. Slow cycling and loss of power.	Replace Driver (11). Supply correct pressure (55-95 PSI). Make sure Exhaust (18) is clear.
Blade driving nail too deeply.	Worn Bumper (12) and/or Piston Spacer.	Replace either or both parts.

All procedures in bold on this chart are to be attempted only by a qualified technician.

Parts List

Part	Description
1	Cylinder Cap
2	O-ring
3	Piston Valve
4	Collar
5	O-ring
6	Lining Ring
7	O-ring
8	O-ring
9	Cylinder
10	O-ring
11	Driver
12	Bumper
13	Nozzle Washer
14	Body
15	Cap Screw
16	Nut
17	Mounting Bracket
18	Exhaust Deflector
19	E-clip
20	Filter
21	End Cap
22	Air Inlet
23	Magazine Latch

Part	Description
24	Latch Spring
25	Retaining Pin
26	Handle
27	O-ring
28	O-ring
29	O-ring
30	Lower Trigger Valve
31	Spring
32	Seal
33	O-ring
34	O-ring
35	Trigger Valve Piston
36	Seal
37	O-ring
38	Upper Trigger Valve
39	O-ring
40	Trigger Plunger
41	Trigger Bracket
42	Trigger
43	Cap Screw
44	Pin
45	Safety Cover
46	Cap Screw

Part	Description
47	Short Cap Screw
48	Safety
49	Safety Spring
50	Safety Guide
51	Cap Screw
52	Cap Screw
53	Spacer
54	Driver Guide
55	Cap Screw
56	Lock Washer
57	Lower Magazine
58	Roll Pin
59	Rear Magazine Cover
60	Pusher
61	Spring Holder
62	Pusher Spring
63	Length Scale
64	Pin Length Selector
65	Upper Right Magazine
66	Nail Guide
67	Nail Guide Bar
68	Pin
69	Upper Left Magazine

PLEASE READ THE FOLLOWING CAREFULLY

THE MANUFACTURER AND/OR DISTRIBUTOR HAS PROVIDED THE PARTS DIAGRAM AND TROUBLESHOOTING GUIDE IN THIS MANUAL AS A REFERENCE TOOL ONLY. NEITHER THE MANUFACTURER NOR DISTRIBUTOR MAKES ANY REPRESENTATION OR WARRANTY OF ANY KIND TO THE BUYER THAT HE OR SHE IS QUALIFIED TO MAKE ANY REPAIRS TO THE PRODUCT OR THAT HE OR SHE IS QUALIFIED TO REPLACE ANY PARTS OF THE PRODUCT. IN FACT, THE MANUFACTURER AND/OR DISTRIBUTOR EXPRESSLY STATES THAT ALL REPAIRS AND PARTS REPLACEMENTS SHOULD BE UNDERTAKEN BY CERTIFIED AND LICENSED TECHNICIANS AND NOT BY THE BUYER. THE BUYER ASSUMES ALL RISK AND LIABILITY ARISING OUT OF HIS OR HER REPAIRS TO THE ORIGINAL PRODUCT OR REPLACEMENT PARTS THERETO, OR ARISING OUT OF HIS OR HER INSTALLATION OF REPLACEMENT PARTS THERETO.

NOTE: Some parts are listed and shown for illustration purposes only and are not available individually as replacement parts.

Assembly Drawing

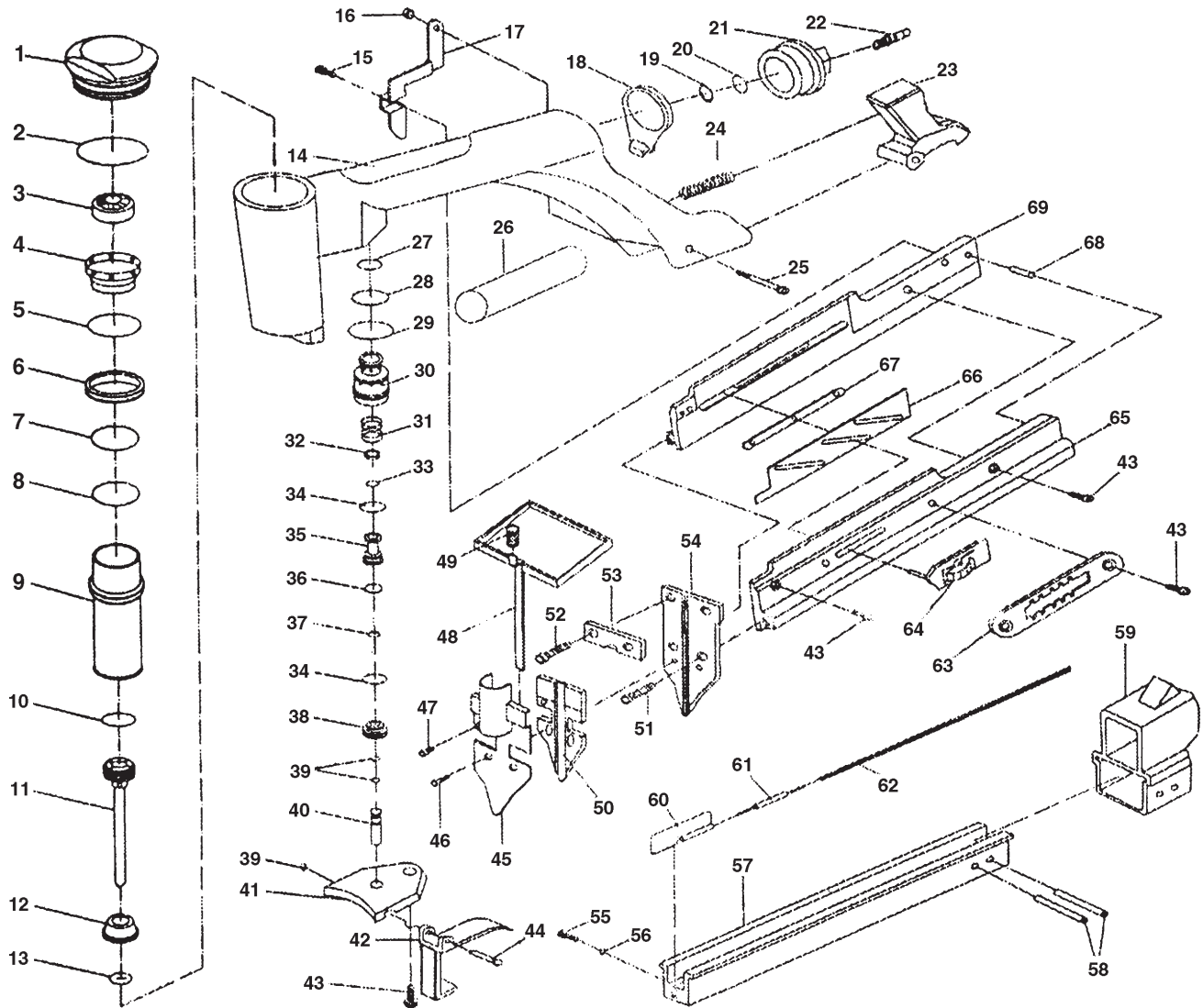

Maintenance

Warning! Always disconnect the tool from the air compressor and then empty the magazine of pins before attempting to inspect or perform maintenance to the Nailer.

1. Inspect all of the nuts and screws and make sure they are securely fastened.
2. Periodically lubricate the driving mechanism and magazine with a light oil. Wipe down with a clean cloth. Never use gasoline or flammable solvents to clean the tool.
3. Inspect your air compressor according to manufacturer's instructions.

Free Manuals Download Website

<http://myh66.com>

<http://usermanuals.us>

<http://www.somanuals.com>

<http://www.4manuals.cc>

<http://www.manual-lib.com>

<http://www.404manual.com>

<http://www.luxmanual.com>

<http://aubethermostatmanual.com>

Golf course search by state

<http://golfingnear.com>

Email search by domain

<http://emailbydomain.com>

Auto manuals search

<http://auto.somanuals.com>

TV manuals search

<http://tv.somanuals.com>