

CENTRAL PNEUMATIC®

CONTRACTOR SERIES

AIR BRAD NAILER

Model 46309

ASSEMBLY and OPERATING INSTRUCTIONS



3491 Mission Oaks Blvd., Camarillo, CA 93011

Visit our Web site at <http://www.harborfreight.com>

**TO PREVENT SERIOUS INJURY,
READ AND UNDERSTAND ALL WARNINGS
AND INSTRUCTIONS BEFORE USE.**

Copyright© 2001, 2004 by Harbor Freight Tools®. All rights reserved.
No portion of this manual or any artwork contained herein may be reproduced
in any shape or form without the express written consent of Harbor Freight Tools.

For technical questions and replacement parts, please call 1-800-444-3353

Specifications

Brad Size	.039-.042" Shank (18 Gauge), 3/8" to 2" long
Magazine Capacity	100
Operating PSI	55-95 PSI
Air Inlet Size	1/4" NPT Male
Safety Feature	Full Sequential Safety Trip Mechanism
Dimensions	9-3/4" L x 8-5/8" H x 2-1/4" W
Accessories	Two Hex Wrenches, Lubricating Oil
Fasteners available from Harbor Freight Tools: SKU 43213 - 18 gauge brad nails, 1000 pieces.	

Save This Manual

You will need the manual for the safety warnings and precautions, assembly instructions, operating and maintenance procedures, parts list and diagram. Keep your invoice with this manual. Write the invoice number on the inside of the front cover. Keep the manual and invoice in a safe and dry place for future reference.

Safety Warnings and Precautions



WARNING: When using tool, basic safety precautions should always be followed to reduce the risk of personal injury and damage to equipment.

Read all instructions before using this tool!

1. **Keep work area clean.** Cluttered areas invite injuries.
2. **Observe work area conditions.** Do not use machines or power tools in damp or wet locations. Do not expose to rain. Keep work area well lit. Do not use electrically powered tools in the presence of flammable gases or liquids.
3. **Keep children away.** Children must never be allowed in the work area. Do not let them handle machines, tools, extension cords, or air hoses.
4. **Store idle equipment.** When not in use, tools must be stored in a dry location to inhibit rust. Always lock up tools and keep out of reach of children.
5. **Use the right tool for the job.** Do not attempt to force a small tool or attachment to do the work of a larger industrial tool. There are certain applications for which this tool was designed. It will do the job better and more safely at the rate for which it was intended. Do not modify this tool and do not use this tool for a purpose for which it was not intended.
6. **Dress properly.** Do not wear loose clothing or jewelry as they can be caught in moving parts. Protective, electrically nonconductive clothes and nonskid footwear are recommended when working. Wear restrictive hair covering to contain long hair.
7. **Do not overreach.** Keep proper footing and balance at all times. Do not reach over or across running machines or air hoses.

8.



Use eye and ear protection. Always wear ANSI approved impact safety goggles and appropriate hearing protection. Wear a full face shield if you are producing metal filings or wood chips. Wear an ANSI approved dust mask or respirator when working around metal, wood, and chemical dusts and mists. Other people in the work area must also wear ANSI approved impact safety goggles.

9. **Maintain tools with care.** Keep tools clean for better and safer performance. Follow instructions for lubricating and changing accessories. Inspect tool cords and air hoses periodically and, if damaged, have them repaired by an authorized technician. The handle must be kept clean, dry, and free from oil and grease at all times. Do not operate a tool if any portion of the tool's operating controls are inoperable, disconnected, altered or not working properly.
10. **Disconnect Air Hose and release any built-up air pressure.** Never service the Nailer, clear jams, or disassemble with the air hose attached. Always release any built-up air even after disconnecting hose. Disconnect the Nailer when not in use.
11. **Remove adjusting keys and wrenches.** Check that keys and adjusting wrenches are removed from the tool or machine work surface before attaching to an air source.
12. **Avoid unintentional starting.** Be sure the trigger is in the Off position when not in use and before plugging in. Do not carry any tool with your finger on the trigger, whether it is attached to an air source or not. Do not point the tool towards yourself or anyone whether it contains fasteners or not.
13. **Stay alert.** Watch what you are doing, use common sense. Do not operate any tool when you are tired.
14. **Check for damaged parts.** Before using any tool, any part that appears damaged should be carefully checked to determine that it will operate properly and perform its intended function. Check for alignment and binding of moving parts; any broken parts or mounting fixtures; and any other condition that may affect proper operation. Any part that is damaged should be properly repaired or replaced by a qualified technician. Do not use the tool if the trigger does not operate properly.
15. **Guard against electric shock.** Prevent body contact with grounded surfaces such as pipes, radiators, ranges, and refrigerator enclosures.
16. **Replacement parts and accessories.** This product is to be repaired and serviced only by a qualified technician. When this product is serviced, only identical replacement parts should be used. Use of any other parts will void the warranty. Only use accessories intended for use with this tool. Approved accessories are available from Harbor Freight Tools.
17. **Do not operate tool if under the influence of alcohol or drugs.** Read warning labels if taking prescription medicine to determine if your judgement or reflexes are impaired while taking drugs. If there is any doubt, do not operate the tool.
18. **Use proper size and type extension cord.** If an extension cord is required, it must be of the proper size and type to supply the correct current to the compressor without heating up. Otherwise, the extension cord could melt and catch fire, or cause electrical damage to the tool. Check your air compressor's manual for the appropriate size cord. It is also possible that the use of an extension cord may cause your circuit breaker to trip or your

panel fuse to break. If this happens, either use the compressor without an extension cord or find a larger amperage circuit to use.

19. **Maintenance.** The maintenance outlined in the maintenance section should be performed regularly. For your safety, this product should be serviced or repaired regularly only by a qualified technician.

20. **Compressed air only.** Never use combustible gas as a power source.

21.  **Do not load nails with the trigger or safety depressed.** Unintentional firing may occur. Do not load nails when the air hose is connected to the tool. Always assume that the tool contains fasteners.

22. **Disconnect air supply before loading Nailer.** Before reloading (or making any adjustments to) the Nailer make sure that the compressed air is disconnected.

23. **Fire fasteners into an appropriate work surface only.** Do not attempt to fire fasteners into surfaces too hard to penetrate. Do not drive fasteners on top of other fasteners, or at too steep of an angle. Fasteners can ricochet causing personal injury. Never fire the Nailer into the air, or point it toward yourself or another person. Always wear ANSI approved safety goggles during use, maintenance, and reloading.

24. **Do not fire fasteners too close to the edge of a workpiece.** They may split the workpiece and fly free, causing personal injury.

25. **Take caution as some woods contain preservatives such as copper chromium arsenate (CCA) which can be toxic.** When stapling or nailing these materials extra care should be taken to avoid inhalation and minimize skin contact.

WARNING: Some dust created by power sanding, sawing, grinding, drilling, and other construction activities, contain chemicals known [to the State of California] to cause cancer, birth defects or other reproductive harm.

Some examples of these chemicals are:

- **Lead from lead-based paints**
- **Crystalline silica from bricks and cement or other masonry products**
- **Arsenic and chromium from chemically treated lumber**

(California Health & Safety Code § 25249.5, *et seq.*)

26. **Stay within air pressure capacity.** Never operate the Nailer above 95 PSI.

27. **Hold tool away from head and body.** During operation the Nailer may kick back causing injury.

28. **Transport Nailer safely.** Always disconnect air supply when moving the tool in the workplace. Carry the tool by the handle and avoid contact with the trigger.

Note: Performance of the compressor (if powered by line voltage) may vary depending on variations in local line voltage. Extension cord usage may also affect tool performance.

Warning: The warnings, cautions, and instructions discussed in this instruction manual cannot cover all possible conditions and situations that may occur. It must be understood by the operator that common sense and caution are factors which cannot be built into this product, but must be supplied by the operator.

Unpacking

When unpacking, check to make sure the parts listed on page 8 are included. If any parts are missing or broken, please call Harbor Freight Tools at the number on the cover of this manual as soon as possible.

NOTE: Although a spare **Drive Pin (46)**, **Step Pin (45)**, **Piston Head (44)**, **O-ring (43)**, and assorted O-rings are included, these parts are for installation by a qualified technician only.

Operation

For best service, you should incorporate an oiler, regulator, and inline filter, as shown in the diagram below. Hoses, couplers, oilers, regulators, and filters are all available at Harbor Freight Tools.

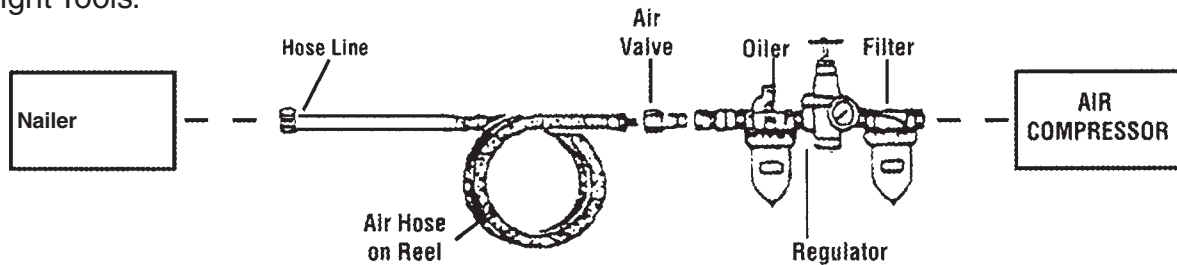

Recommended Air Line Components

Note: To connect this tool, we recommend a quick coupler/adaptor (not included). Coupler/adapters are available at Harbor Freight Tools. If an automatic oiler is not used, put 3-5 drops of pneumatic tool oil in the **Air Inlet (38)** before each use.

Testing the Full Sequential Safety Trip Mechanism

Warning: Even though the nailer should be empty during this procedure, **ALWAYS** point the nailer at a piece of scrap wood when testing.

1. Make sure the tool is disconnected from the power supply.
2. Completely empty the magazine of nails.
3. The Nailer should not fire if the nose is not depressed against the workpiece.
4. Check that the **Trigger (29)** and the **Safety (56)** move freely, without sticking - see *Figure 1*, next page.
5. Connect the air supply to the tool at the **Air Inlet (38)** set at the recommended 55-95 PSI, and not to go over the maximum 95 PSI.
6. Test the tool by depressing the **Safety (56)** against the workpiece without pulling the **Trigger (29)**. **The tool must not cycle (fire)**. If it cycles (fires), stop immediately and take the tool to an authorized service technician.
7. Hold the tool away or off of the workpiece. The **Safety (56)** of the tool should return to its original position. Squeeze the **Trigger (29)**. **The tool should not cycle (fire)**. If it cycles (fires), stop immediately and take the tool to an authorized service technician.
8. Depress the **Safety (56)** against the workpiece and squeeze the **Trigger (29)**. **The tool must cycle (fire) once only**. Release the trigger and squeeze it again. **The tool must not cycle (fire)**. With the Trigger held, carefully lift the nailer and press it against the workpiece again. **The tool must not cycle (fire)**. If it fails to act in the manner described in bold, have it repaired by a qualified service technician.

REV 04/05

Operation (continued)

FIGURE 1

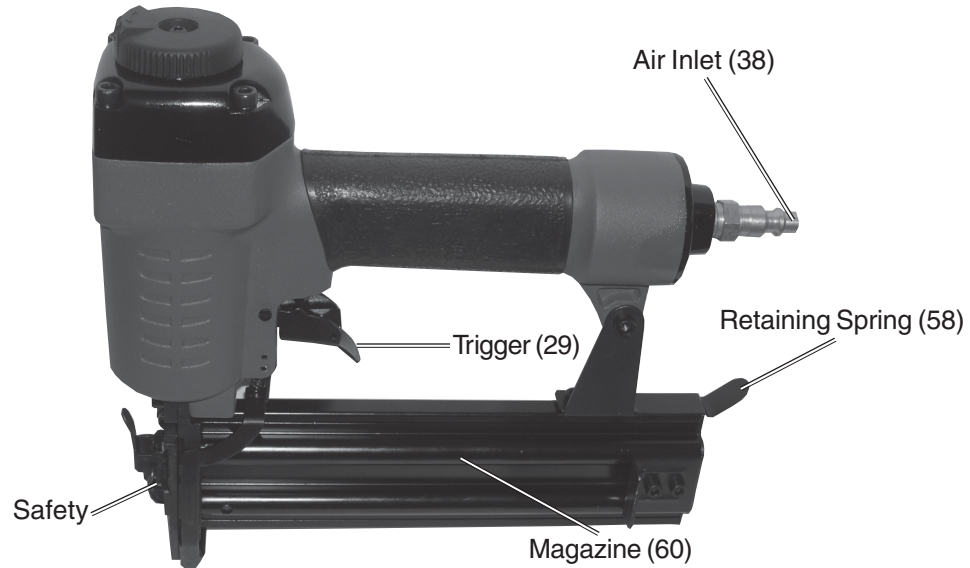

Loading Brad Nails



ALWAYS WEAR ANSI APPROVED IMPACT SAFETY GOGGLES WHEN RELOADING OR DOING ANY OTHER MAINTENANCE ON THIS TOOL. Other people in the work area must also wear ANSI approved impact safety goggles.

Warning! Make sure the Nailer is not attached to the air hose whenever loading the tool.

1. Press the **Retaining Spring (58)** up and slide the **Magazine (60)** back.
2. Holding the nailer with the nose pointing slightly down, insert the brad nails into the **Magazine (60)**, letting the pointed end ride on the rail of the **Magazine (60)**.
3. After the Nails reach the nose of the tool, close the **Magazine (60)** making sure the **Retaining Spring (58)** clicks shut. See *Figure 1*.

Operating the Nailer

1. Attach the Nailer to the air supply at the **Air Inlet (38)**. Start your compressor and check the pressure making sure it is set at the recommended 55-95 PSI and not to go over the maximum 95 PSI.
2. To fire, place the nose of the Nailer on the workpiece. The Nailer should not fire if the nose is not depressed. Once depressed, gently and briefly squeeze the **Trigger (29)** once. **Do not fire repeatedly.** Nails could bounce off of one another, damaging the work piece or causing PERSONAL INJURY.

Anytime *any* maintenance or repairs are done (including clearing jams), FIRST:

1. Disconnect the Nailer from the air hose.
2. Empty the **Magazine (60)** completely.
3. Attempt to fire the Nailer into a piece of scrap wood to ensure that it is disconnected and is incapable of firing any brads.
4. **Always leave the Magazine (60) open during maintenance. The Magazine is spring-loaded and may cause parts or a nail to fly out of the Nailer.**

Clearing Jams

1. Disconnect tool from air hose, empty the **Magazine (60)** of nails, release any built-up air pressure, and leave the magazine open, as explained above.
2. While doing this step and the next, hold the Nailer pointed away from you and any other people or fragile objects. Pull the **Quick Release Lever (49)** forward to the position shown in *Figure 2*. Remove the **Driver Guide Cover (51)**.
3. Remove the jammed nail. Pliers may be necessary to remove a stuck nail.
4. Inspect the **Drive Pin (46)** for bends or breakage - see location in *Figure 3*. If it is damaged, do not use the tool until it is repaired by a qualified technician.
5. Lightly oil the **Drive Pin (46)**. Replace the **Driver Guide Cover (51)** and latch the **Quick Release Spring (50)** up against **both** hooks, making sure it is securely in place and the **Quick Release Lever (49)** is pressed down - see *Figure 4*.
6. Reload the Nailer.
7. Reconnect the Nailer to the air hose.
8. Press the **Safety (56)** of the Nailer against an appropriate piece of scrap wood.
9. Test fire the Nailer several times, checking for proper operation.
10. Disconnect the Nailer, remove the nails and store it in a location out of children's reach.

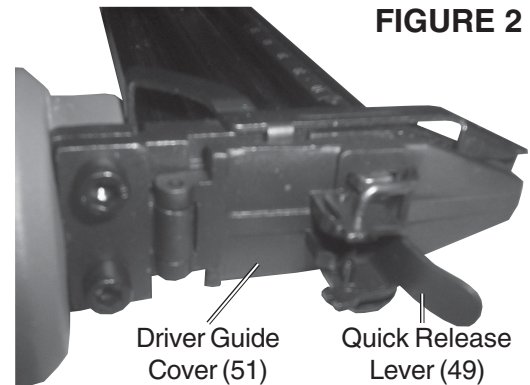

FIGURE 2

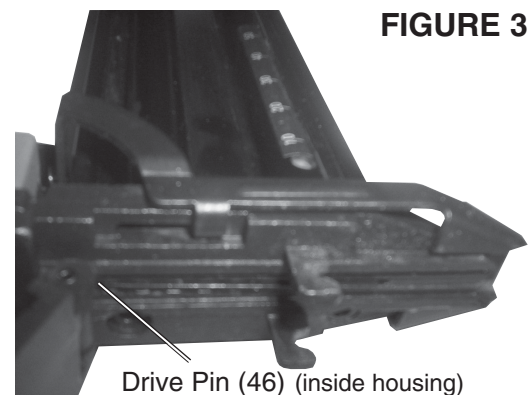

FIGURE 3

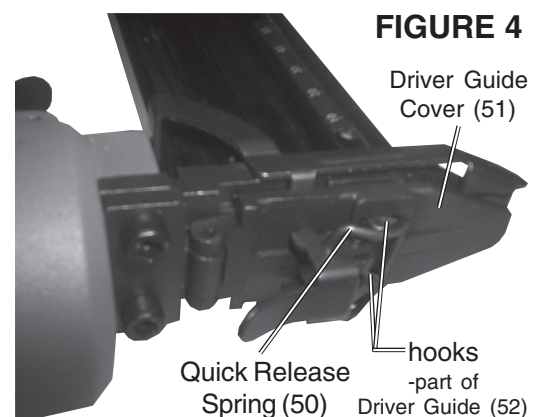

FIGURE 4

Anytime any maintenance or repairs are done, FIRST:

1. Disconnect the Nailer from the air hose.
2. Empty the **Magazine (60)** completely.
3. Attempt to fire the Nailer into a piece of scrap wood to ensure that it is disconnected and is incapable of firing any brads.
4. **Always leave the Magazine (60) open during maintenance. The Magazine is spring-loaded and may cause parts or a nail to fly out of the Nailer.**

Troubleshooting Guide

**Stop using the Brad Nailer immediately if any of the following problems occur.
Repairs and part replacements must be done only by a qualified technician.
All procedures in bold on this chart are to be attempted only by a qualified technician.**

Problem	Likely Cause	Solution
Air leaking at Trigger area.	O-Rings in Trigger Valve housing are damaged.	Replace O-Rings and check contact trip operation.
Air leaking between Housing and Nose.	Loose screws in Housing. Damaged O-Rings/Bumper (17).	Tighten screws. Replace O-Rings or Bumper (17).
Air leaking at Trigger Valve Stem.	O-Rings or Seals are damaged.	Replace O-Rings or Seals.
Air leaking between Housing and Cap.	Loose screws. Damaged Gasket (7).	Tighten Screws. Replace Gasket (7).
Runs slowly or has power loss.	Insufficient oil. Broken Spring in Cylinder Cap. Exhaust (1) is blocked.	Lubricate as instructed. Replace Compression Spring (6). Replace damaged parts.
Nailer skips a nail.	Worn Bumper (17) or damaged Pusher Spring. Dirt in Driver Guide (52). Inadequate airflow to Nailer. Worn or dry O-Ring on Piston. Damaged O-Ring on Trigger Valve. Cap Gasket (7) leaking.	Replace Bumper (17) or Pusher Spring. Clean Channels in Driver Guide (52). Check hose and compressor fittings. Replace or lubricate O-Rings. Replace O-Rings. Replace Gasket (7).
Nails are jammed.	Guide on driver is worn. Nails are wrong size or damaged. Magazine or Nose screws are loose. Drive Pin (46) is damaged.	Replace Guide. Use correct, undamaged nails. Tighten screws. Replace Drive Pin (46).
Nailer will not drive down tight.	Rounded Drive Pin (46) slipping off nail crown. Lack of air pressure. Slow cycling and loss of power.	Replace Drive Pin (46). Supply correct pressure (55-95 PSI). Check Compression Spring (6) for broken coils or reduced length. Make sure Exhaust (1) is clear.
Blade driving nail too deeply.	Worn Bumper (17) and/or Piston Spacer.	Replace either or both parts.

All procedures in bold on this chart are to be attempted only by a qualified technician.

Parts List

Part	Description	Part	Description	Part	Description
1	Exhaust	24	Trigger Valve Stem	47	Screw
2	Screw	25	O-Ring	48	Cover II
3	Washer	26	Valve Guide	49	Quick Release Lever
4	Cylinder Cap Assembly	27	Releasing Blade	50	Spring
5	Seal Air	28	E-ring	51	Driver Guide Cover
6	Compression Spring	29	Trigger	52	Driver Guide
7	Gasket	30	Spring Pin	53	Screw
8	O-ring	31	Step Pin	54	Spring Pin
9	O-ring	32	Frame	55	Spring
10	Head Valve Piston	33	Spring Pin	56	Safety
11	O-Ring	34	Stopper	57	Screw
12	Stopper	35	Filter Net	58	Retaining Spring
13	Collar	36	O-ring	59	Support
14	O-ring	37	Bottom Cap	60	Magazine
15	O-ring	38	Air Inlet	61	Steel Bar
16	Cylinder	39	Screw	62	Magazine Side Cover
17	Bumper	40	Washer	63	Cover
18	Body	41	Pin	64	Spring
19	Nozzle	42	Spring	65	Spring Pin
20	Cover	43	O-ring	66	Pusher Guide
21	Trigger Axle Head	44	Piston Head	67	Pusher
22	Spring	45	Step Pin	68	Screw
23	O-Ring	46	Drive Pin	69	Hex Nut

PLEASE READ THE FOLLOWING CAREFULLY

THE MANUFACTURER AND/OR DISTRIBUTOR HAS PROVIDED THE PARTS DIAGRAM AND TROUBLESHOOTING GUIDE IN THIS MANUAL AS A REFERENCE TOOL ONLY. NEITHER THE MANUFACTURER NOR DISTRIBUTOR MAKES ANY REPRESENTATION OR WARRANTY OF ANY KIND TO THE BUYER THAT HE OR SHE IS QUALIFIED TO MAKE ANY REPAIRS TO THE PRODUCT OR THAT HE OR SHE IS QUALIFIED TO REPLACE ANY PARTS OF THE PRODUCT. IN FACT, THE MANUFACTURER AND/OR DISTRIBUTOR EXPRESSLY STATES THAT ALL REPAIRS AND PARTS REPLACEMENTS SHOULD BE UNDERTAKEN BY CERTIFIED AND LICENSED TECHNICIANS AND NOT BY THE BUYER. THE BUYER ASSUMES ALL RISK AND LIABILITY ARISING OUT OF HIS OR HER REPAIRS TO THE ORIGINAL PRODUCT OR REPLACEMENT PARTS THERETO, OR ARISING OUT OF HIS OR HER INSTALLATION OF REPLACEMENT PARTS THERETO.

NOTE: Some parts are listed and shown for illustration purposes only and are not available individually as replacement parts.

Assembly Drawing

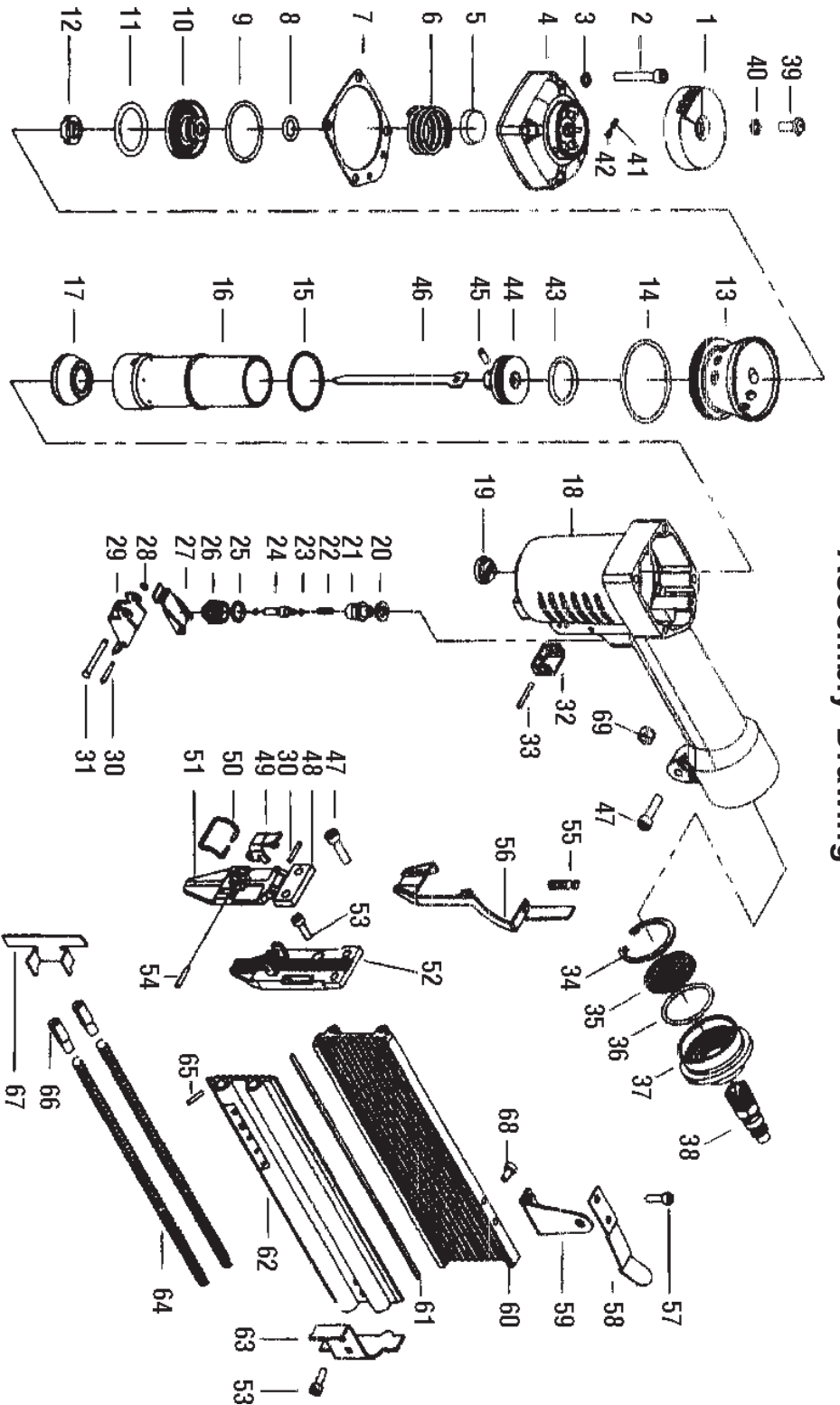

Maintenance

Warning! Always disconnect the tool from the air compressor and then empty the magazine of nails before attempting to inspect or perform maintenance to the Nailer.

1. Inspect all of the nuts and screws and make sure they are securely fastened.
2. Periodically lubricate the driving mechanism and magazine with a light oil. Wipe down with a clean cloth. Never use gasoline or flammable solvents to clean the tool.
3. Inspect your air compressor according to manufacturer's instructions.

Free Manuals Download Website

<http://myh66.com>

<http://usermanuals.us>

<http://www.somanuals.com>

<http://www.4manuals.cc>

<http://www.manual-lib.com>

<http://www.404manual.com>

<http://www.luxmanual.com>

<http://aubethermostatmanual.com>

Golf course search by state

<http://golfingnear.com>

Email search by domain

<http://emailbydomain.com>

Auto manuals search

<http://auto.somanuals.com>

TV manuals search

<http://tv.somanuals.com>