

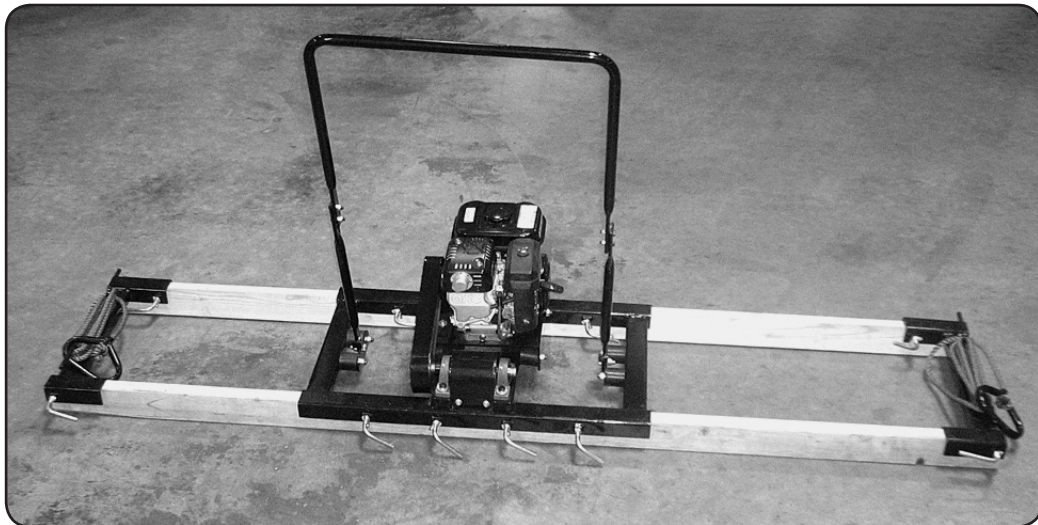

4.5 HP VIBRATORY SCREED

Model 96126

ASSEMBLY AND OPERATION INSTRUCTIONS



Due to continuing improvements, actual product may differ slightly from the product described herein.

Distributed Exclusively by Harbor Freight Tools®.

3491 Mission Oaks Blvd., Camarillo, CA 93011

Visit our website at: <http://www.harborfreight.com>

**TO PREVENT SERIOUS INJURY, READ AND UNDERSTAND
ALL WARNINGS AND INSTRUCTIONS BEFORE USE.**

Copyright© 2007 by Harbor Freight Tools®. All rights reserved. No portion of this manual or any artwork contained herein may be reproduced in any shape or form without the express written consent of Harbor Freight Tools.

For technical questions or replacement parts, please call 1-800-444-3353.

SPECIFICATIONS

Gasoline Engine	Robin®/5FJXS.1271GA/Model#: EX130D500216711 127 cc 4.5 HP 4-cycle engine
Clutch Design	Centrifugal Clutch
Drive Type	A-710 V-Belt Drive
Engine Approvals	2006 EPA Phase II; 2006 CA Emissions Regulations
Maximum Beam Length	15' with Spreaders
Screed Spreaders	(2) 7-1/8"L x 21-1/8"W
Overall Dimensions	21-1/8"W x 34-7/8"L x 44-5/8"H
Net Weight	116 Lbs.

Save This Manual

You will need this manual for the safety warnings and precautions, assembly, operating, inspection, maintenance and cleaning procedures, parts list and assembly diagram. Keep your invoice with this manual. Write the invoice number on the inside of the front cover. Write the product's serial number in the back of the manual near the assembly diagram, or write month and year of purchase if product has no number. Keep this manual and invoice in a safe and dry place for future reference.

SAFETY RULES

 **WARNING!**

READ AND UNDERSTAND ALL INSTRUCTIONS
Failure to follow all instructions listed below may result in
electric shock, fire, and/or serious injury.
SAVE THESE INSTRUCTIONS

WARNING: When using tool, basic safety precautions should always be followed to reduce the risk of personal injury and damage to equipment.

Read all instructions before using this tool!

1. **Keep work area clean.** Cluttered areas invite injuries.
2. **Observe work area conditions.** Do not use machines or tools in damp or wet locations. Don't expose to rain. Keep work area well lit.
3. **Keep children away.** Children must never be allowed in the work area. Do not let them handle machines, or tools. Never allow children to play with or climb on Screed.
4. **Store idle equipment.** When not in use, tools must be stored in a dry location to inhibit rust. Always lock up tools and keep out of reach of children.
5. **Use the right tool for the job.** Do not attempt to force a small tool or attachment to do the work of a larger industrial tool. There are certain applications for which this tool was designed. It will do the job better and more safely at the rate for which it was

intended. Do not modify this tool and do not use this tool for a purpose for which it was not intended.

6. **Dress properly.** Do not wear loose clothing or jewelry as they can be caught in moving parts. Protective, electrically nonconductive clothes and nonskid footwear are recommended when working. Wear restrictive hair covering to contain long hair.
7. **Use eye protection.** Always wear ANSI approved impact safety goggles.
8. **Do not overreach.** Keep proper footing and balance at all times. Do not reach over or across an engine, Screed or other machines while in use.
9. **Maintain tools with care.** Keep tools clean and maintained for better and safer performance. Follow instructions for lubricating and changing accessories. The handle must be kept clean, dry, and free from oil and grease at all times.
10. **Stay alert.** Watch what you are doing, use common sense. Do not operate any tool when you are tired.
11. **Check for damaged parts.** Before using any tool, any part that appears damaged should be carefully checked to determine that it will operate properly and perform its intended function. Check for alignment and binding of moving parts; any broken parts or mounting fixtures; and any other condition that may affect proper operation. Any part that is damaged should be properly repaired or replaced by a qualified technician. Do not use the tool if any switch does not turn On and Off properly.
12. **Replacement parts and accessories.** When servicing, use only identical replacement parts. Use of any other parts will void the warranty. Only use accessories intended for use with this tool. Approved accessories are available from Harbor Freight Tools.
13. **Do not operate tool if under the influence of alcohol or drugs.** Read warning labels if taking prescription medicine to determine if your judgment or reflexes are impaired while taking drugs. If there is any doubt, do not operate the tool.
14. **Be aware that prolonged exposure to vibration can lead to personal injury (which may include hand, wrist and arm injury).** If you experience discomfort or pain after using this tool, you should contact your physician prior to further use of the tool.
15. **Maintenance.** For your safety, service and maintenance should be performed regularly by a qualified technician.
16. **WARNING!** Stand clear of the Screed when it is in operation. Keep unnecessary spectators away from this machine while in operation. Never ride on Screed.
17. **WARNING! Fire Hazard.** Do not fill gas tank when engine is running or hot. Do not operate engine near spilled gasoline. Clean spilled gasoline before starting engine. Do not store or handle gasoline near pilot light, electrical equipment or open flame. Do not smoke near gasoline.
18. **WARNING! Carbon Monoxide Hazard.** Operate Vibratory Screed in well ventilated area only. Carbon Monoxide is created when engine is running and is a DEADLY gas when inhaled. Carbon Monoxide is a colorless, odorless gas. Early signs of Carbon Monoxide

poisoning resemble Flu symptoms such as headache, dizziness or nausea. If you notice these signs, turn off engine and immediately move to a well ventilated area.

19. **WARNING! Burn Hazard.** The engine becomes hot during operation. Do not touch the engine until it has cooled down after use.
20. **Warning: The warnings, cautions, and instructions discussed in this instruction manual cannot cover all possible conditions and situations that may occur.** It must be understood by the operator that common sense and caution are factors which cannot be built into this product, but must be supplied by the operator.

UNPACKING

When unpacking, check to make sure the item is intact and undamaged. If any parts are missing or broken, please call Harbor Freight Tools at the number on the cover of this manual as soon as possible.

VIBRATION HAZARD

This tool vibrates during use. Repeated or long-term exposure to vibration may cause temporary or permanent physical injury, particularly to the hands, arms and shoulders. To reduce the risk of vibration-related injury:

1. Anyone using vibrating tools regularly or for an extended period should first be examined by a doctor and then have regular medical check-ups to ensure medical problems are not being caused or worsened from use. Pregnant women or people who have impaired blood circulation to the hand, past hand injuries, nervous system disorders, diabetes, or Raynaud's Disease should not use this tool. If you feel any medical or physical symptoms related to vibration (such as tingling, numbness, and white or blue fingers), seek medical advice as soon as possible.
2. Do not smoke during use. Nicotine reduces the blood supply to the hands and fingers, increasing the risk of vibration-related injury.
3. Wear suitable gloves to reduce the vibration effects on the user.
4. Use tools with the lowest vibration when there is a choice between different processes.
5. Include vibration-free periods each day of work.
6. Grip tool as lightly as possible (while still keeping safe control of it). Let the tool do the work.
7. To reduce vibration, maintain the tool as explained in this manual. If any abnormal vibration occurs, stop use immediately.

ASSEMBLY

Your Vibratory Screed is shipped assembled, except for attachment of the handle.

Assemble the Handle and Spreaders

1. Attach the (2) Lower Handles (31) to the Upper Handle (27) using Hex Bolts (30) and Locking Hex Nuts (17). Tighten securely.
2. Attach the Handle Assembly to the Handle Brackets (34), using Hex Bolts (32), Hex Washers (33) and Hex Lock Nuts (20).
3. Install Spreader Boards (not included) into the Frame (1). For most applications, use standard 2x4 or 2x6 boards of equal length. Specially shaped boards or spreaders of other material can be fabricated and used as required for special circumstances. The Spreader Boards should be installed in the U Channels of the Frame (1), and centered overall in the Vibratory Screed tool. Tighten the boards into place using the L Bolts (3) and Wing Nuts (2) installed on the Frame (1).
4. Check the installation of the Screed Boards on a flat surface to be sure they are level. You may have to adjust them before beginning work.
5. Recheck all bolts and fasteners periodically during work to ensure the assembly remains stable, safe and level.

Check the Engine

1. **CAUTION: To prevent accidental starting, remove the spark plug wire before working on the engine.**
2. **WARNING: Only operate the engine in a well ventilated area.** When running, gasoline engines produce Carbon Monoxide, a deadly, odorless and colorless gas which is highly toxic. Please review safety warnings on page 3 for more information.
3. **WARNING: Do not add gasoline while engine is running or is hot.** Gasoline is extremely flammable. Spilling gasoline on a hot engine may cause fire or explosion.
4. Every time before starting engine, remove Oil Cap and check Oil Level. You can read the oil level on the dip stick. If the oil level is low, add oil until the level is in the correct range on the dip stick. **DO NOT OVERFILL.** In warm weather, use SAE 30 weight oil. In cold weather, use SAE 5-20 multigrade oil. Follow instructions in engine manufacturer's owner's manual for specific oil maintenance.

Starting the Engine

1. The engine supplied with your Vibratory Screed is the Robin EX13 model. This engine has a manual choke, manual throttle control and centrifugal clutch. This is a 4-cycle engine which runs on “regular” gasoline and does not require oil to be mixed in the gas. In addition to the recommendations below, follow the instructions for starting and operating the engine as well as all safety instructions provided by the engine manufacturer.
2. Before starting, check to see that there is gasoline in the fuel tank. If the fuel level is low, fill with fresh, clean “regular” gasoline. Do not add oil to the gasoline.
3. Close the manual choke all the way.
4. Pull the starting cord 3 or 4 times to introduce gasoline vapor into the cylinder.
5. Move the manual choke to its 1/2 closed position.
6. Gently pull on the starting cord until tension is felt. Ease on the cord to allow it to retreat fully. Pull hard on starting cord. The engine should start with the first or second pull.
7. Once the engine is started, let it warm up. As it warms, gradually open the choke until it is fully open. You may then begin to use the tool.
8. If the engine does not start or run properly following these procedures, check the troubleshooting section in the engine manufacturer’s owners manual.

OPERATION

1. This Vibratory Screed tool is designed for leveling and settling freshly poured cement in a form. This Owner’s Manual assumes that the operator has an understanding of the use of concrete and cement products.
2. The site must be properly designed and prepared according to the intended use, local building codes, and characteristics of the site.
3. The ground must be dug out, leveled or sloped appropriately, and the form created with 2x4 or 2x6 material. The form must be level or slightly sloped as desired. The screed will ride along the upper surface of the form. The form must be sturdy and properly staked into position.
4. If the Screed Boards exceed a length of 15’, use the Spreaders (37 and 38) to keep the Screed Boards apart.
5. Pour in and spread the underlayment, which may be sand or gravel. If needed, position rebar or mesh reinforcement. Expansion bars may also be positioned if needed.
6. Pour in the cement mixture, and spread it with shovels to fill the form and roughly smooth the concrete.
7. Place the Screed on one end of the form and start the engine. To do this, turn the engine switch to **ON**. Then pull on the engine throttle.

8. Once the engine has warmed up, increase engine speed to engage the Clutch (25) and start vibrating the tool.
9. The Screed may be pulled or pushed along the form using the Handle (27). It may also be pulled along the form using Ropes and Grips (35, 36).
10. The Screed will level the concrete mixture even with the top of the form. During the Screed operation, use a shovel to fill in any gaps in the concrete. It may be necessary to make more than one pass along the form to create a smooth and level surface.
11. In addition to leveling the concrete, the vibration of the Screed improves the characteristics of the concrete mixture. The vibration causes heavier aggregate elements to sink lower in the mixture, and smaller elements to come to the top. This results in a smoother surface which is easier to properly finish .
12. Once the concrete mixture is properly leveled and the desired surface is achieved, shut the engine off by turning engine switch to **OFF**. Remove the Screed from the form and proceed with standard concrete finishing operations.
13. Allow the Engine to cool.
14. After each use of the Screed, rinse it thoroughly with water to remove cement from Wing Nuts (2) L Bolts (3), and any other parts that may be damaged by cement accumulation. Wipe down the machine and store it properly. Avoid splashing water on the engine and the gasoline refill cap.

MAINTENANCE

1. Keep the Screed clean and dry.
2. Periodically lubricate the Wing Nuts (2) and L Bolts (3).
3. Periodically check the Drive Belt (4). Be sure it is tight and in good condition. Replace the belt if it is cracked or damaged. To replace the belt, remove the four Engine Mount Bolts (24). Rotate the engine on the Eccentric (11). Pull off the Drive Belt (4). Replace the belt, rotate the engine back on the eccentric, and replace the engine mount bolts. Tighten securely.
4. Check the oil level every time before using the engine. Fill oil if necessary. If oil leaks are detected, or the engine is using excessive oil, contact a qualified service technician.
5. Drive Belt Adjustment: Tighten or loosen the Drive Belt by loosening the four Engine Mount Bolts (24), adjusting the position of the Engine and retightening the bolts. Never operate the engine while the Engine Mount Bolts are loose.
6. Have a qualified service technician periodically service the Gasoline Engine (23).

TROUBLESHOOTING

1. Engine does not start or runs rough: Check fuel and oil levels to be sure they are within range. Check spark plug wire to be sure there is a good connection. Check spark plug gap to be sure it is clean and within range as listed in engine manufacturer's owners's manual. Review the instructions given on page 5 for starting and operating the engine. If engine trouble persists, take the machine to a qualified service technician for service.

PARTS LIST - VIBRATORY SCREED

Part	Description	Q'ty
1	Frame	1
2	Wing Nut m12	10
3	L Bolt	10
4	Drive Belt A710	1
5	Sheave	1
6	Hex Lock Screw m8x10	1
7	Hex Bolt m8x20	4
8	Eccentric Guard	1
9	Pillow Block with Bearing UEL205	2
10	Pin	1
11	Eccentric	1
12	Flat Washer m10	4
13	Lock Washer m10	4
14	Hex Bolt m10x40	4
15	Nut Plate	2
16	Shock Mount	8
17	Hex Lock Nut m8	9
18	Washer	4
19	Motor Base	1

Part	Description	Q'ty
20	Hex Lock Nut m12	20
21	Pin	1
22	O Ring m8	8
23	Gasoline Engine Robin EX13	1
24	Engine Mount Bolts m8x45	4
25	Clutch	1
26	Bracket	1
27	Upper Handle	1
28	Hex Bolt m8x25	4
29	Belt Guard	1
30	Hex Bolt m8x30	4
31	Lower Handle	2
32	Hex Bolt m12x35	2
33	Washer m12	6
34	Handle Bracket	2
35	Grip	2
36	Rope	2
37	Left Spreader	1
38	Right Spreader	1

PLEASE READ THE FOLLOWING CAREFULLY

THE MANUFACTURER AND/OR DISTRIBUTOR HAS PROVIDED THE PARTS LIST AND ASSEMBLY DIAGRAM IN THIS MANUAL AS A REFERENCE TOOL ONLY. NEITHER THE MANUFACTURER OR DISTRIBUTOR MAKES ANY REPRESENTATION OR WARRANTY OF ANY KIND TO THE BUYER THAT HE OR SHE IS QUALIFIED TO MAKE ANY REPAIRS TO THE PRODUCT, OR THAT HE OR SHE IS QUALIFIED TO REPLACE ANY PARTS OF THE PRODUCT. IN FACT, THE MANUFACTURER AND/OR DISTRIBUTOR EXPRESSLY STATES THAT ALL REPAIRS AND PARTS REPLACEMENTS SHOULD BE UNDERTAKEN BY CERTIFIED AND LICENSED TECHNICIANS, AND NOT BY THE BUYER. THE BUYER ASSUMES ALL RISK AND LIABILITY ARISING OUT OF HIS OR HER REPAIRS TO THE ORIGINAL PRODUCT OR REPLACEMENT PARTS THERETO, OR ARISING OUT OF HIS OR HER INSTALLATION OF REPLACEMENT PARTS THERETO.

LIMITED 90 DAY WARRANTY

Harbor Freight Tools Co. makes every effort to assure that its products meet high quality and durability standards, and warrants to the original purchaser that this product is free from defects in materials and workmanship for the period of 90 days from the date of purchase. This warranty does not apply to damage due directly or indirectly, to misuse, abuse, negligence or accidents, repairs or alterations outside our facilities, criminal activity, improper installation, normal wear and tear, or to lack of maintenance. We shall in no event be liable for death, injuries to persons or property, or for incidental, contingent, special or consequential damages arising from the use of our product. Some states do not allow the exclusion or limitation of incidental or consequential damages, so the above limitation of exclusion may not apply to you. THIS WARRANTY IS EXPRESSLY IN LIEU OF ALL OTHER WARRANTIES, EXPRESS OR IMPLIED, INCLUDING THE WARRANTIES OF MERCHANTABILITY AND FITNESS.

To take advantage of this warranty, the product or part must be returned to us with transportation charges prepaid. Proof of purchase date and an explanation of the complaint must accompany the merchandise. If our inspection verifies the defect, we will either repair or replace the product at our election or we may elect to refund the purchase price if we cannot readily and quickly provide you with a replacement. We will return repaired products at our expense, but if we determine there is no defect, or that the defect resulted from causes not within the scope of our warranty, then you must bear the cost of returning the product.

This warranty gives you specific legal rights and you may also have other rights which vary from state to state.

3491 Mission Oaks Blvd. • PO Box 6009 • Camarillo, CA 93011 • (800) 444-3353

ASSEMBLY DIAGRAM - VIBRATORY SCREED

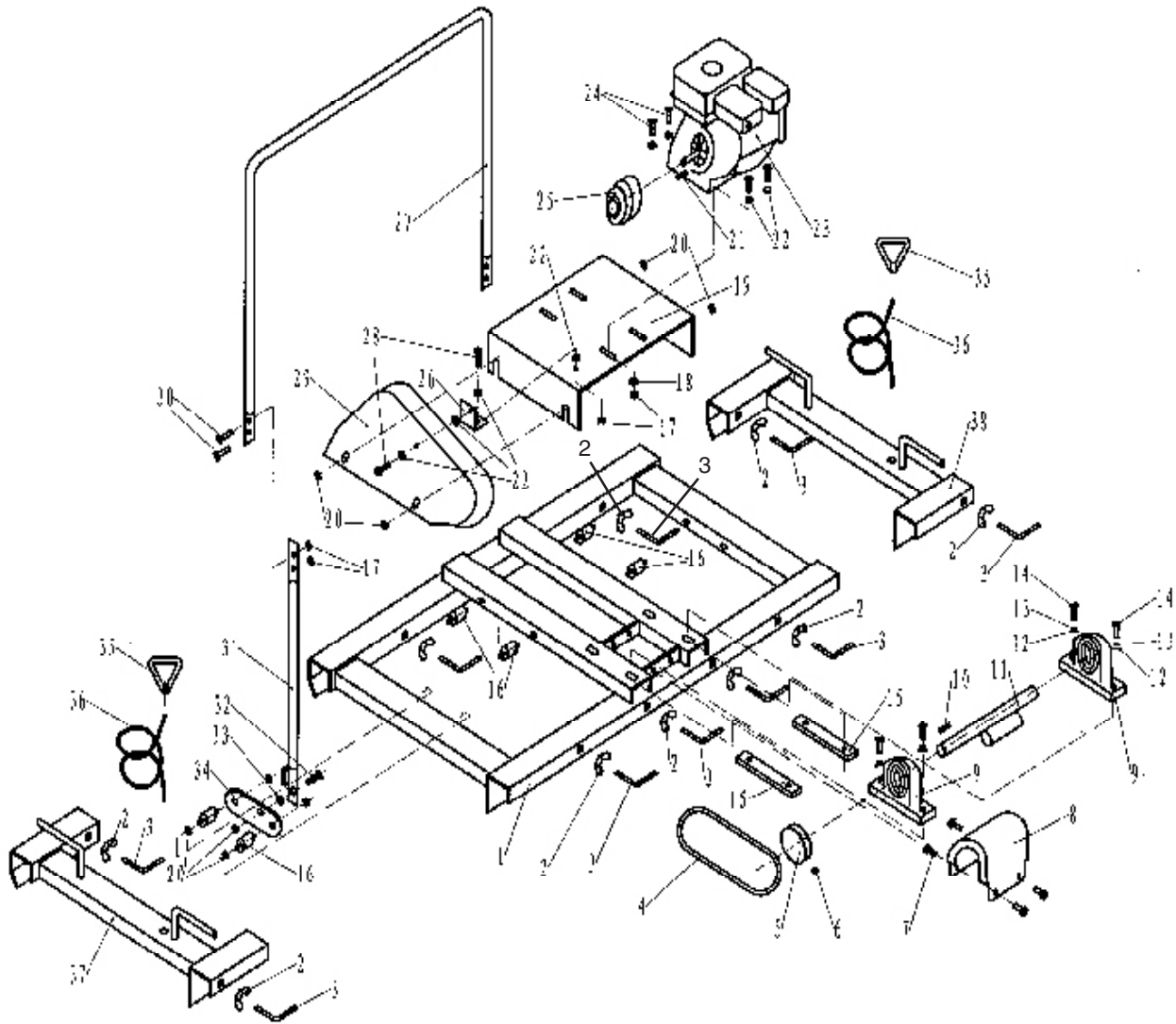

Record Product's Serial Number Here: _____

Note: If product has no serial number, record month and year of purchase instead.

Note: Some parts are listed and shown for illustration purposes only, and are not available individually as replacement parts.

Free Manuals Download Website

<http://myh66.com>

<http://usermanuals.us>

<http://www.somanuals.com>

<http://www.4manuals.cc>

<http://www.manual-lib.com>

<http://www.404manual.com>

<http://www.luxmanual.com>

<http://aubethermostatmanual.com>

Golf course search by state

<http://golfingnear.com>

Email search by domain

<http://emailbydomain.com>

Auto manuals search

<http://auto.somanuals.com>

TV manuals search

<http://tv.somanuals.com>