

CENTRAL MACHINERY[®]
INDUSTRIAL

10 IN 1 METAL & WOODWORKING MACHINE

Model 96067

ASSEMBLY AND OPERATING INSTRUCTIONS

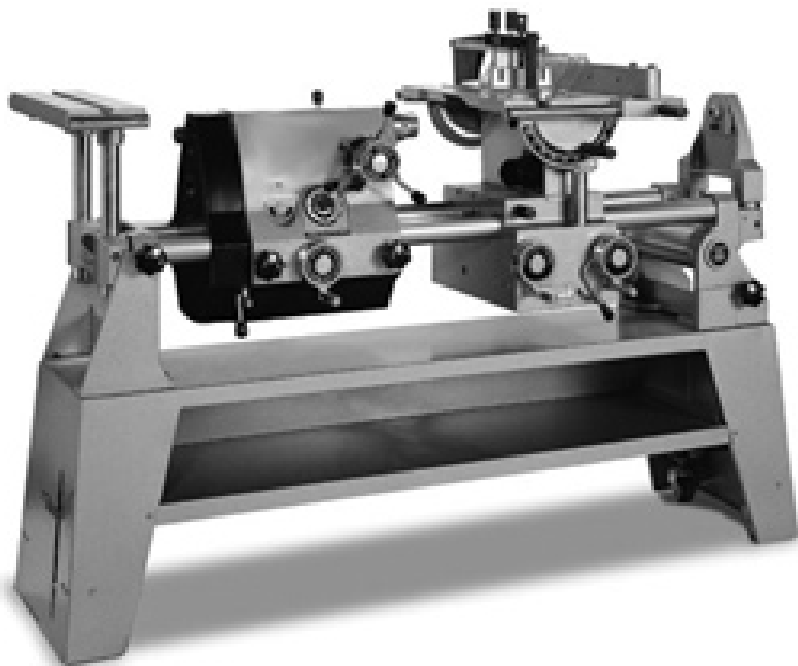

Due to continuing improvements, actual product may differ slightly from the product described herein.



3491 Mission Oaks Blvd., Camarillo, CA 93011

Visit our website at: <http://www.harborfreight.com>

**TO PREVENT SERIOUS INJURY, READ AND UNDERSTAND
ALL WARNINGS AND INSTRUCTIONS BEFORE USE.**

Copyright© 2007 by Harbor Freight Tools[®]. All rights reserved. No portion of this manual or any artwork contained herein may be reproduced in any shape or form without the express written consent of Harbor Freight Tools.

For technical questions or replacement parts, please call 1-800-444-3353.

CONTENTS

SPECIFICATIONS	4
GENERAL SAFETY RULES	5
WORK AREA	5
PERSONAL SAFETY.....	5
TOOL USE AND CARE	6
SERVICE.....	6
SPECIFIC SAFETY RULES	7
MECHANICAL PRECAUTIONS	7
NOISE PRECAUTION.....	8
TABLE SAW SAFETY RULES	8
DRILL PRESS SAFETY RULES.....	11
LATHE SAFETY RULES.....	12
ROUTER/SHAPER SAFETY RULES	13
HORIZONTAL BORING SAFETY RULES.....	13
DISC SANDER SAFETY RULES	14
GROUNDING	15
MISC. SAFETY RULES	15
EXTENSION CORDS.....	16
SYMBOLOLOGY	17
UNPACKING.....	17
PRODUCT FEATURES	18
THE POWER KEY	19
TO MOVE THE POWERHEAD	19
TO MOVE THE QUILL FEED.....	19
TO ADJUST SPEED BELTS AND PULLEYS	19
TO MOUNT COLLETS WITH THE DRAWBAR.....	20
TO MOVE THE CARRIAGE.....	20
ASSEMBLY INSTRUCTIONS.....	21
TO ATTACH THE SHELF TO THE STAND	21
TO INSTALL THE CASTERS	21
TO MOUNT THE MACHINE ONTO THE STAND.....	22
TO ATTACH A SAW BLADE TO THE ARBOR	23
TO INSTALL THE LOWER BLADE GUARD.....	24
TO ASSEMBLE THE MAIN TABLE.....	25
TO INSTALL THE EXTENSION TABLE	26
TO INSTALL THE RIP FENCE AND TOP GUARD	27
TO INSTALL THE MITER GAUGE	27
TO INSTALL THE DISC SANDER.....	28
TO SET UP THE VERTICAL DRILL PRESS.....	28
TO SET UP THE HORIZONTAL BORING TOOL.....	29
TO SET UP THE SHAPER.....	30
TO SET UP THE ROUTER	30
TO SET UP THE LATHE.....	31
MACHINE ADJUSTMENT INSTRUCTIONS	32
TO ADJUST THE TORSION SPRING TENSION	32
TO ALIGN THE SAW TABLE TO THE SAW BLADE.....	34
TO ALIGN THE SAW TABLE 90 DEGREES TO THE SAW BLADE	34

CONTENTS (continued)

TO ADJUST THE SAW TABLE'S 45 DEGREE STOP	35
TO ALIGN THE MITER GAUGE	35
TO ALIGN THE EXTENSION TABLE 90 DEGREES TO THE SAW BLADE.....	35
TO SET THE CARRIAGE BUMPER BOLT	36
TO ALIGN THE SAW TABLE 90 DEGREES TO THE POWERHEAD	36
TO ALIGN THE LATHE TAILSTOCK WITH THE POWERHEAD	37
PARTS LISTS AND DIAGRAMS	38
PARTS LIST - CABINET & CASTERS.....	38
ASSEMBLY DIAGRAM - CABINET & CASTERS.....	39
PARTS LIST - MAIN BED	40
ASSEMBLY DIAGRAM - MAIN BED	41
PARTS LIST -HEAD ASSY.	42
ASSEMBLY DIAGRAM - HEAD ASSY.	44
PARTS LIST - CARRIAGE ASSY.	45
ASSEMBLY DIAGRAM - CARRIAGE ASSY.	46
PARTS LIST - SAW TABLE ASSY.	47
ASSEMBLY DIAGRAM - SAW TABLE ASSY.	48
PARTS LIST - SAW GUARD ASSY.	49
ASSEMBLY DIAGRAM - SAW GUARD ASSY.	50
PARTS LIST - RIP FENCE ASSEMBLY DIAGRAM.....	51
PARTS LIST & ASSY. DIAGRAM - LATHE TAILSTOCK ASSY.	52
PARTS LIST & ASSY. DIAGRAM - EXT. TABLE ASSY.	53
PARTS LIST & ASSY. DIAGRAM - SANDING DISC ASSY.	54
PARTS LIST & ASSY. DIAGRAM - TOOL MOUNTING ASSEMBLIES	55
PARTS LIST & ASSY. DIAGRAM - TOOL REST	56
PARTS LIST & ASSY. DIAGRAM - MITER GAUGE ASSY.....	57
PARTS LIST - ELECTRICAL SYSTEM	58
ASSEMBLY DIAGRAM - ELECTRICAL SYSTEM	59
LIMITED 1 YEAR / 90 DAY WARRANTY	60

SPECIFICATIONS

Electrical Requirements	120 VAC / 7.5 A / Single Phase/15 Amps at full load 1.5 HP Motor Power Cord Type: 14 AWG x 3 C / 8' Long Power Switch Type: 2-Position Key Switch
Machine Features	Table Saw / Disc Sander / Boring Machine Lathe / Drill Press / Router & Shaper / Mill Machine
Accessories	Sanding Disc Assy. (Qty. 1) / Drill Press Insert (Qty. 1) / Router (Qty. 1) Air Breather Mask (Qty. 1) Earplug Set (Qty. 1) / R8 Collet (Qty. 1) Drawbar Handle (Qty. 1) / Wood Turning Faceplate (Qty. 1) / Dead Center (Qty. 1) Center Cup (Qty. 1) / Tension Wrench (Qty. 1) / Wrench Nut (Qty. 1) Saw Arbor (Qty. 1) Lathe Tool Rest & Post (Qty. 1) / Shaper Arbor (Qty. 1) Rip Fence (Qty. 1) / Miter Gauge Assy. (Qty. 1) / Upper Saw Guard Assy. (Qty. 1) Extension Table Assy. (Qty. 1) / Spindle Guard (Qty. 1) 11-7/8" Disc Grinding Pads (Qty. 2)
Lathe Swing/Taper	17-5/16" (440mm) / #2 Morse Taper
Quill Travel	4-15/16" (125mm)
Distance Between Centers	33-7/8" (860mm)
Vertical Mill	20-7/8" (530mm)
Maximum Depth of Cut	3-15/16" (100mm)
Taper of Spindle Bore A	M.T. #5
Drilling Capacity	5/8" (16mm)
Disc Sander	12" Diameter
Wooding Cutting Blade Size	10" or 12"
Speed Range	Variable 32 to 7200 RPM
Table Size	23" L x 17" W x 2" H
Hole Through Spindle Bore B	29/32" (23mm)
Overall Size	68.5" x 21.6" x 40.7"
Net Weight	456 Pounds

Note: This tool is pre-wired with a 120 V power cord and plug. This tool is dual voltage (120V/220V). Converting this tool to 220V should only be done by a certified electrician.

Save This Manual

You will need this manual for the safety warnings and precautions, assembly, operating, inspection, maintenance and cleaning procedures, parts list and assembly diagram. Keep your invoice with this manual. Write the invoice number on the inside of the front cover. Write the product's serial number in the back of the manual near the assembly diagram, or write month and year of purchase if product has no number. Keep this manual and invoice in a safe and dry place for future reference.

GENERAL SAFETY RULES

 **WARNING!**



READ AND UNDERSTAND ALL INSTRUCTIONS
Failure to follow all instructions listed below may result in
electric shock, fire, and/or serious injury.
SAVE THESE INSTRUCTIONS

WORK AREA

1. **Keep your work area clean and well lit.** Cluttered and dark areas invite accidents.
2. **Do not operate power tools in explosive atmospheres, such as in the presence of flammable liquids, gases, or dust.** Power tools create sparks which may ignite the dust or fumes.
3. **Keep bystanders, children, and visitors away while operating a power tool.** Distractions can cause you to lose control. Protect others in the work area from debris such as chips and sparks. Provide barriers or shields as needed. Children should never be allowed in the work area.

PERSONAL SAFETY

1. **Stay alert. Watch what you are doing, and use common sense when operating a power tool. Do not use a power tool while tired or under the influence of drugs, alcohol, or medication.** A moment of inattention while operating power tools may result in serious personal injury.
2. **Dress properly. Do not wear loose clothing or jewelry. Contain long hair. Keep your hair, clothing, and gloves away from moving parts.** Loose clothes, jewelry, or long hair can be caught in moving parts.
3. **Remove adjusting keys or wrenches before turning the power tool on.** A wrench or a key that is left attached to a rotating part of the power tool may result in personal injury.

4. **Do not overreach. Keep proper footing and balance at all times.** Proper footing and balance enables better control of the power tool in unexpected situations.
5.  **Use safety equipment. Always wear ANSI-approved safety impact goggles when using this product.** Dust mask or respirator, nonskid safety shoes, hard hat, or hearing protection must be used for appropriate conditions.  Always wear ANSI-approved safety goggles and a dust mask/respirator when using or performing maintenance on this tool.

TOOL USE AND CARE

1. **Do not force the tool. Use the correct tool for your application.** The correct tool will do the job better and safer at the rate for which it is designed. Do not force the tool and do not use the tool for a purpose for which it is not intended.
2. **Do not use the Metal/Woodworking Machine if its Power Switch does not turn it on or off.** Any equipment that cannot be controlled with the Power Switch is dangerous and must be replaced.
3. **Turn off the Power Switch and disconnect the Power Cord before making any adjustments, changing accessories, or storing the Metal/Woodworking Machine.** Such preventive safety measures reduce the risk of starting the tool accidentally. **Always turn off the Power Switch and disconnect the Power Cord before performing any inspection, maintenance, or cleaning procedures.**
4. **Store idle tools out of reach of children and other untrained persons.** Tools are dangerous in the hands of untrained users.
5. **Maintain tools with care. Keep the Metal/Woodworking Machine clean.** Properly maintained tools are less likely to malfunction and are easier to control. Do not use a damaged tool. Tag damaged tools “Do not use” until repaired.
6. **Check for misalignment or binding of moving parts, breakage of parts, and any other condition that may affect the tool’s operation. If damaged, have the tool serviced before using.** Many accidents are caused by poorly maintained tools.
7. **Use only accessories that are recommended by the manufacturer for your model.** Accessories that may be suitable for one tool may become hazardous when used on another tool.

SERVICE

1. **Tool service must be performed only by qualified repair personnel.** Service or maintenance performed by unqualified personnel could result in a risk of injury.

2. **When servicing a tool, use only identical replacement parts. Follow instructions in the “Inspection, Maintenance, And Cleaning” section of this manual.** Use of unauthorized parts or failure to follow maintenance instructions may create a risk of injury.

SPECIFIC SAFETY RULES

1. **Maintain labels and nameplates on the Metal/Woodworking Machine.** These carry important information. If unreadable or missing, contact Harbor Freight Tools for a replacement.
2. **Always consult the Speed Chart in this manual before operating any tool of the Metal/Woodworking Machine.**
3. **Maintain a safe working environment.** Make sure there is adequate surrounding workspace.
4. **Avoid unintentional starting.** Make sure you are prepared to begin work before turning on the Metal/Woodworking Machine.
5. **People with pacemakers should consult their physician(s) before use.** Electromagnetic fields in close proximity to a heart pacemaker could cause pacemaker interference or pacemaker failure.
6. **Never leave the Metal/Woodworking Machine unattended when it is running.** Turn off the Machine before leaving the work area.
7. **Keep all safety guards of the Metal/Woodworking Machine in place and in proper working order.**
8. **Never stand on the Metal/Woodworking Machine.** Serious injury could occur if the unit is tipped or the Cutter is accidentally touched.
9. **Make sure the workpiece is free from nails and any other foreign object which could break or otherwise damage the Metal/Woodworking Machine.**
10. **Never start the Metal/Woodworking Machine under a load.** Allow the Machine to reach full speed before feeding a workpiece into the Machine.
11. **Maintain control of the workpiece at all times.** Never allow a workpiece to rest on the running Machine without holding on to it or using appropriate clamps

MECHANICAL PRECAUTIONS

1. **Prior to performing service, maintenance, or cleaning procedures, always make sure the Metal/Woodworking Machine’s Power Switch is in its “OFF” position and the Power Cord is disconnected from its electrical outlet.**

2. **Do not alter or adjust any part of the Metal/Woodworking Machine or its internal mechanisms that are assembled and supplied by the manufacturer or distributor.**
3. **Always follow and complete scheduled maintenance.**

NOISE PRECAUTION

Prolonged exposure to high noise levels is hazardous to hearing. Always wear ANSI-approved hearing protection when operating or working around the Metal/Woodworking Machine when it is running.

TABLE SAW SAFETY RULES

1. **Avoid unintentional starting.** Make sure you are prepared to begin work before turning on the Table Saw.
2. **Do not force the Table Saw.** This tool will do the work better and safer at the speed and capacity for which it was designed. Do not force the Saw Blade into the workpiece being cut.
3.  **WARNING!** Keep hands and fingers away from cutting area and Saw Blade. Use a “push stick” (not included) if necessary.
4. **Never leave the Table Saw unattended when it is plugged into an electrical outlet.** Turn off the tool, and unplug it from its electrical outlet before leaving.
5. **Always use Saw Blades with a 7” to 12” diameter, 5/8” round arbor hole, and rated at 7200 RPM or greater.** Saw Blades that do not match the mounting hardware of the Table Saw or that are rated less than the required minimum RPM will run eccentrically causing loss of control or may fly off the Saw, resulting in severe personal injury and/or property damage.
6. **Do not use the Table Saw for cutting metals or for cutting curves.** This will cause the Saw Blade to break and/or reduce its service life.
7. **Make sure the Table of the Table Saw and surrounding area are clear with the exception of the workpiece to be cut.**
8. **Before using the Table Saw, check to make sure the Saw Blade is properly mounted on the Saw Spindle.** Always adhere to safety warnings and instructions provided by saw blade manufacturer. Make sure the Saw Blade is

balanced, and is not cracked or bent.

9. **Never attempt to cut more than one workpiece at a time.**
10. **Never attempt to cut freehand.** Make sure the workpiece to be cut is pressed firmly against the Table.
11. **When cutting a large workpiece, make sure its entire length is properly supported.** If necessary, use a roller stand (not included).
12. **Always feed the workpiece against the rotation of the Saw Blade.**
13. **Allow the Saw Blade to spin up to full speed before feeding it into a workpiece.** When turning off the Table Saw, allow the Saw Blade to spin down and stop on its own. Do not press against the Saw Blade to stop it.
14. **To avoid accidental injury, always wear heavy duty work gloves when changing the Saw Blade.**
15. **The Saw Blade will become hot while cutting.** Allow the Saw Blade to completely cool before handling.
16. **Do not force the workpiece into the Saw Blade when cutting.** Apply moderate pressure, allowing the Saw Blade to cut without being forced.
17. **Turn off the Table Saw and allow the Saw Blade to completely stop if the Saw Blade is to be backed out of an uncompleted cut.**
18. **Never attempt to remove material stuck in the moving parts of the Table Saw while it is plugged in and running.**
19. **Make sure the woodstock to be cut has sufficient room to move sideways.** Failure to do so may result in off-cut binding against the Saw Blade.
20. **Always unplug the Table Saw from its electrical outlet before performing inspection, maintenance, cleaning procedures, or changing accessories.**
21. **Before trying new or complicated techniques practice with scrap wood.**
22. **Make sure the woodstock is free from loose knots, flaws, nails, and any other foreign objects that could damage the Saw Blade or cause “kickback”.**
23. **Causes and operator prevention of “kickback”:** Kickback is a sudden reaction

to a pinched, bound, or misaligned Saw Blade, causing an uncontrolled woodstock to lift up and out from the Table Saw toward the operator. When the Saw Blade is pinched or bound tightly by the kerf closing down, the Saw Blade stalls and the motor reaction drives the woodstock rapidly back toward the operator. If the Saw Blade becomes twisted or misaligned in the cut, the teeth at the back edge of the Saw Blade can raise the woodstock (walk up), and eject it toward the operator. Kickback is a result of tool misuse and/or incorrect operating procedures or conditions and can be avoided by taking proper precautions as given below:

- * Maintain control of the woodstock at all times. Never allow the woodstock to rest on the moving Saw Blade without holding on to the woodstock.
- * When the Saw Blade is binding, or when interrupting a cut for any reason, turn off the Power Switch and hold the woodstock motionless on the Table Saw until the Saw Blade comes to a complete stop. Never attempt to remove the woodstock from the Table Saw or pull the woodstock backward while the Saw Blade is in motion or kickback may occur. Investigate and take corrective actions to eliminate the cause of Saw Blade binding.
- * When restarting a woodstock on the Table Saw, center the Saw Blade in the pre-cut kerf and check that the Saw Teeth are not engaged into the woodstock. If the Saw Blade is binding, the woodstock may walk up or kick back as the Table Saw is restarted.
- * Support large panels with roller stands (not included) to minimize the risk of Saw Blade pinching and kickback. Large panels tend to sag under their own weight. Supports must be placed under the panel and near the outer edge of the panel.
- * Do not use a dull or damaged Saw Blade. Dull or improperly set Saw Blades produce a narrow kerf causing excessive friction, Saw Blade binding or kickback.
- * Never use the Fence assembly as a guide when crosscutting.
- * Never rip a wood stock that is twisted or warped, or does not have a straight edge to guide along the Rip Fence.
- * Push the woodstock past the Saw Blade prior to release.

24. **Check all guards for proper operation before each use. Never disable guards.** Do not operate the Table Saw if the guard assembly does not move freely and close instantly. Before each use, raise the guard assembly and make sure it moves freely and does not touch the Saw Blade or any other part, in all angles and depths of cut.
25. **Never perform layout, assembly, or setup work on the Table of the Table Saw when the machine is running.**
26. **Make sure to remove all adjusting wrenches from the Table Saw before turning it on.**
27. **Use a “push stick” or “auxiliary handle” (neither included) only when ripping widths of 2” to 6”.** Use a “push block” and “auxiliary fence” (neither included) when ripping widths under 2”.
28. **Keep the Table of the Table Saw clean and clear of debris.** Remove cut-off pieces and scraps of wood from the Table before starting the Table Saw.

DRILL PRESS SAFETY RULES

1. **Avoid unintentional starting.** Make sure you are prepared to begin work before turning on the Drill Press.
2. **Do not force the Drill Press.** This tool will do the work better and safer at the speed and capacity for which it was designed.
3.  **WARNING!** Keep hands and fingers safety away from the cutting area.
4. **Never leave the Drill Press unattended when it is plugged into an electrical outlet.** Turn off the tool, and unplug it from its electrical outlet before leaving.
5. **Make sure the Table of the Drill Press and surrounding area are clear with the exception of the workpiece to be drilled.**
6. **Before using the Drill Press, check to make sure the bit is properly mounted in the Chuck.** Make sure the Bit is sharp, and is not cracked or bent.
7. **Never attempt to drill more than one workpiece at a time.**
8. **Never attempt to drill freehand.** Make sure the workpiece to be drilled is secured in a vise or is clamped to the table.

9. **When drilling a large workpiece, make sure its entire length is properly supported.** If necessary, use a roller stand (not included).
10. **Keep all guards in place, in proper adjustment, and in proper alignment.**
11. **Do not use rotary planers, wire wheels, or router bits on the Drill Press.**
12. **Always feed the workpiece into and against the rotational direction of a bit or cutter.**
13. **When drilling softer materials or small holes, use the higher speed settings. When drilling harder materials or holes, use the slower speed settings.**
14. **Allow the bit to spin up to full speed before feeding it into a workpiece.** When turning off the Drill Press, allow the bit to spin down and stop on its own. Do not press against the bit to stop it.
15. **The bit will become hot while drilling.** Allow the bit to completely cool before handling.
16. **Do not force the bit into the workpiece when drilling.** Apply moderate pressure, allowing the bit to cut without being forced.
17. **Turn off the Drill Press and allow the machine to completely stop if the bit is to be backed out of an uncompleted cut.**
18. **Never attempt to remove material stuck in the moving parts of the Drill Press while it is plugged in and running.**

LATHE SAFETY RULES

1. **Make sure all adjusting wrenches are removed from the Lathe prior to turning on the machine.**
2. **Keep all safety guards in proper working order, proper adjustment, and proper alignment.**
3. **Make sure the workpiece is securely mounted in the Lathe before turning on the machine.** A loose workpiece can fly off the Lathe, causing severe personal injury and/or property damage.
4. **Always keep hands and fingers as far away as possible from the moving parts of the Lathe.** Do not reach over or across the Lathe when it is running.

5. **Allow the workpiece to turn up to full speed before feeding a tool bit (not included) into the workpiece.** When turning off the Lathe, allow the workpiece to slow down and stop on its own. Do not press against the workpiece to stop it.
6. **Feed the tool bit into the workpiece gradually.** Do not force a tool bit to remove material faster than it is designed to cut.
7. **Never attempt to remove material stuck in the moving parts of the Lathe while it is plugged in and/or running.**

ROUTER/SHAPER SAFETY RULES

1. **Avoid unintentional starting.** Make sure you are prepared to begin work before turning on the Router/Shaper.
2. **Never leave the Router/Shaper unattended when it is running.** Turn off the Router/Shaper before leaving the work area.
3. **Always feed the workpiece against the rotation of the Cutter.**
4. **In addition to the Fence Jig, always use the Disc Guard unless the Cutter is too short.** When routing, use the Fence Jig for piloted router bits, edging, and facing procedures.
5. **Always make multiple, shallow passes instead of one deep pass.**
6. **Make sure to keep hands and fingers away from the Cutter.** Whenever possible, use “pushsticks” and “pushblocks” (neither included) to feed the workpiece into the Cutter.
7. **Keep all safety guards of the Router/Shaper in place and in proper working order.**
8. **Make sure the workpiece is free from nails and any other foreign object which could break or otherwise damage the Cutter.**
9. **Never start the Router/Shaper under a load.** Allow the Router/Shaper to reach full speed before feeding a workpiece into the Cutter.
10. **Maintain control of the workpiece at all times.** Never allow a workpiece to rest on the moving Cutter without holding on to it.

HORIZONTAL BORING SAFETY RULES



1. **Avoid unintentional starting.** Make sure you are prepared to begin work before turning on the Router/Shaper.
2. **Never leave the Router/Shaper unattended when it is running.** Turn off the Router/Shaper before leaving the work area.
3. **Always place scrap wood behind the workpiece to prevent damage to the drill bit and to avoid splintering.**
4. **Always firmly support and guide the wood before and during drilling.**
5. **Use only the speeds listed in the Speed Chart.**
6. **Make sure the bit never touches the Table, Rip Fence, or Miter Gauge.**
7. **Keep your body away from the drill bit when it is exposed and rotating.**
8. **Keep all safety guards in place and in proper working order.**
9. **Make sure the workpiece is free from nails and any other foreign object which could break or otherwise damage the drill bit.**
10. **Never start the the machine under a load.** Allow the machine to reach full speed before feeding a drill bit into the workpiece.

DISC SANDER SAFETY RULES

1. **Always stand on the left of the Sanding Disc's center.** Never stand on the right side of center.
2. **Keep hands and fingers away from the Sanding Disc and the nearest edge of the Table.**
3. **Use only the speeds listed in the Speed Chart.**
4. **Hold the workpiece firmly when feeding it into the Sanding Disc.**
5. **Use only enough pressure to touch the workpiece lightly against the Sandpaper on the Disc.**
6. **Before sanding, turn on the Disc Sander and check for excessively loose Sanding Disc.**
7. **Allow the Sanding Disc to spin up to full speed before feeding a workpiece into it.** Do not ever feed a workpiece past the center line of the disc. When turning off the Disc Sander, allow the Sanding Disc to slow down and stop on its own. Do not press against the Sanding Disc to stop it.

8. **Feed the workpiece into the Sanding Disc gradually and into the direction of rotation.** Do not attempt to force the Disc Sander to remove material faster than it is designed to cut.
9. **When replacing the Sanding Disc, make sure the Disc has a minimum 900 RPM rating, and has a 12" diameter.**
10. **When sanding a large workpiece, make sure its entire length is properly supported.**
11. **Never attempt to remove material stuck into the moving parts of the Disc Sander when it is plugged in and running.**

MISC. SAFETY RULES

1.  **WARNING!** Some dust created by power sanding, sawing, grinding, drilling, and other construction activities, contains chemicals known [to the State of California] to cause cancer, birth defects or other reproductive harm. Some examples of these chemicals are:
Lead from lead-based paints
Crystalline silica from bricks and cement or other masonry products
Arsenic and chromium from chemically treated lumber
Your risk from these exposures varies, depending on how often you do this type of work. To reduce your exposure to these chemicals: work in a well ventilated area, and work with approved safety equipment, such as those dust masks that are specially designed to filter out microscopic particles. (California Health & Safety Code § 25249.5, et seq.)
2.  **WARNING!** The warnings and precautions discussed in this manual cannot cover all possible conditions and situations that may occur. It must be understood by the operator that common sense and caution are factors which cannot be built into this product, but must be supplied by the operator.

GROUNDING

WARNING!

Improperly connecting the grounding wire can result in the risk of electric shock. Check with a qualified electrician if you are in doubt as to whether the outlet is properly grounded. Do not modify the power cord plug provided with the tool. Never remove the grounding prong from the plug. Do not use the tool if the power cord or plug is damaged. If damaged, have it repaired by a service facility before use. If the plug will not fit the outlet, have a proper outlet installed by a qualified electrician.

Your tool must be plugged into an appropriate outlet, properly installed and grounded in accordance with all codes and ordinances.



EXTENSION CORDS

1. As the distance from the supply outlet increases, you must use a heavier gauge extension cord. Using extension cords with inadequately sized wire causes a serious drop in voltage, resulting in loss of power and possible tool damage.
(See Figure B, next page.)
2. The smaller the gauge number of the wire, the greater the capacity of the cord. For example, a 14 gauge cord can carry a higher current than a 16 gauge cord.
(See Figure B, next page.)
3. When using more than one extension cord to make up the total length, make sure each cord contains at least the minimum wire size required.
(See Figure B, next page.)
4. If you are using one extension cord for more than one tool, add the nameplate amperes and use the sum to determine the required minimum cord size.
(See Figure B, next page.)
5. If you are using an extension cord outdoors, make sure it is marked with the suffix "W-A" ("W" in Canada) to indicate it is acceptable for outdoor use.
6. Make sure your extension cord is properly wired and in good electrical condition. Always replace a damaged extension cord or have it repaired by a qualified electrician before using it.
7. Protect your extension cords from sharp objects, excessive heat, and damp or wet areas.

RECOMMENDED MINIMUM WIRE GAUGE FOR EXTENSION CORDS*					
NAMEPLATE AMPERES (at full load)	EXTENSION CORD LENGTH				
	25 Feet	50 Feet	75 Feet	100 Feet	150 Feet
0 – 2.0	18	18	18	18	16
2.1 – 3.4	18	18	18	16	14
3.5 – 5.0	18	18	16	14	12
5.1 – 7.0	18	16	14	12	12
7.1 – 12.0	18	14	12	10	-
12.1 – 16.0	14	12	10	-	-
16.1 – 20.0	12	10	-	-	-

FIGURE B * Based on limiting the line voltage drop to five volts at 150% of the rated amperes.

Symbology

	Double Insulated	$V\sim$	Volts Alternating Current
	Canadian Standards Association	A	Amperes
	Underwriters Laboratories, Inc.	n_0 xxxx/min.	No Load Revolutions per Minute (RPM)

UNPACKING

When unpacking, check to make sure all of the parts shown on the Parts List in this manual are included. If any parts are missing or broken, please call Harbor Freight Tools at the number shown on the cover (and at the bottom of each page) of this manual as soon as possible.

PRODUCT FEATURES

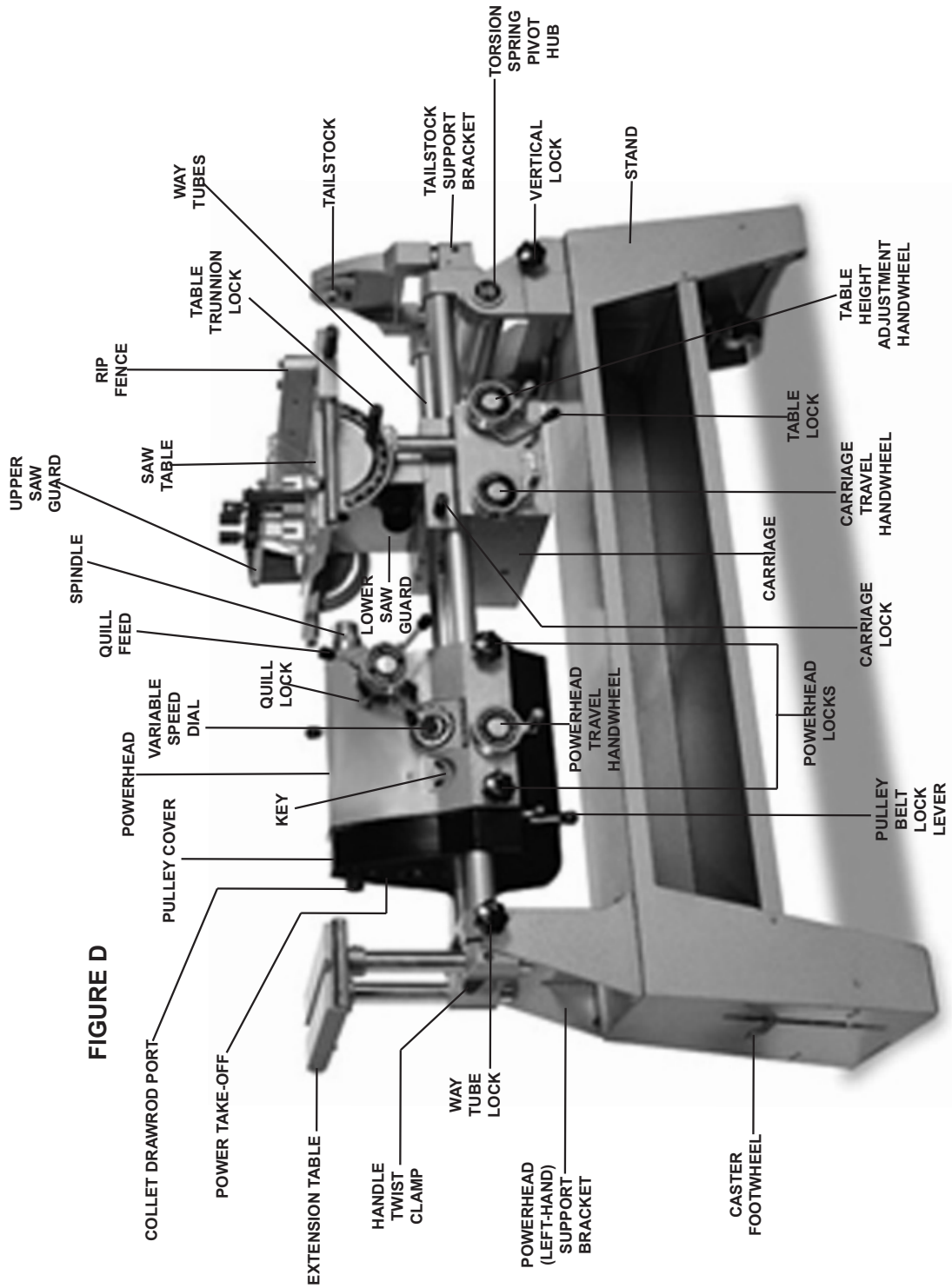

FIGURE D

THE POWER KEY

The Power Key is used to turn the Metal/Woodworking Machine on and off. Always keep the Power Key out of reach of children and other unauthorized people. Before turning the Key to its "ON" position, make sure the Variable Speed Control Dial is set at its lowest setting. **(See page 16 and 17.)**

TO MOVE THE POWERHEAD

To slide the Powerhead on the way tubes loosen the two Lock Knobs. Then crank the Travel Hand Wheel. The Powerhead and Carriage travel on Way Tubes. The Way Tubes allow for more precise movement of the Powerhead in horizontal or vertical positions. Always retighten both Lock Knobs after positioning the Powerhead. **(See page 16 and 27.)**

TO MOVE THE QUILL FEED

The Quill Feed Handles located on the front and back of the Powerhead extend 5" from the Quill. Behind the front Quill Feed Handle is the Quill Feed Lock. Make sure to engage the Lock once the Quill has been extended.

TO ADJUST SPEED BELTS AND PULLEYS

1. The Powerhead features a lower and upper Pulley located under the Pulley Cover. A decal on top of the Pulley Cover refers to the V-Belt location on the Upper Pulley. The V-Belt for all three Pulley configurations must be straight. Never attempt to cross a Lower Pulley with one that is not directly above it. The decal illustrates pulley selection to corresponding RPM:
 - a. Position #1 = 32 to 900 RPM
 - b. Position #2 = 1200 to 3600 RPM
 - c. Position #3 = 4000 to 7200 RPM
2. To change speeds with different Pulley positions:
 - a. Loosen the Pulley Cover Lock on the back of the Woodworking Machine.
 - b. Slide the Pulley Cover away from the Powerhead.
 - c. Lift the Belt Tension Lock Lever up.
 - d. Lift the Motor Mount Bracket up to release tension on the V-Belts.
 - e. While slowly rotating the Upper Pulley, pull the V-Belt off its Pulley.
 - f. Reposition the V-Belt on the new, matched, Pulley setting.
 - g. Push the Motor Mount Bracket down to tighten the V-Belt tension. Then push the Belt Tension Lock Lever down to keep the desired tension on the V-Belt.
 - h. Set the Pulley Cover back in place and tighten the Cover Lock. **(See page 16.)**

TO MOUNT COLLETS WITH THE DRAWBAR

The Drawbar/R-8 Collet combination is used with all of the tools of the Metal/Woodworking Machine. To attach R-8 Collets, pass the Drawbar through the Spindle from the left. Align the keyway in the exterior of the Collet with the Key in the Spindle and slide the R-8 Collet into the Spindle from the right. Insert the Drawbar into the left end of the Spindle in the place marked "Drawbar." Turn the Drawbar and thread it into the Collet until the Collet is tight in the Spindle. **(See page 16.)**

TO MOVE THE CARRIAGE

1. The Carriage has three functions:
 - a. To adjust the height of the saw Table.
 - b. To support the Tool Rest.
 - c. To provide left/right and up/down movement for adjustments in horizontal boring and milling projects.
2. The height adjustment is geared for the saw Table's Way Tubes. Pull up on the Table Lock to tighten it.
3. Before moving the Carriage to the left or right you must release the Carriage Lock with a clockwise turn. Then turn the Carriage Travel Hand Wheel in the opposite way of the direction you want to go.
4. **WARNING!** Always check all Locks before operating the Metal/Woodworking Machine. Always ensure the Carriage and any installed Table or Lathe Tool Rest are locked down (unless they are being moved). Failure to completely lock the Table, the Carriage, or the Powerhead can result in personal injury and/or damage to the Machine. **(See page 16.)**

ASSEMBLY INSTRUCTIONS

TO ATTACH THE SHELF TO THE STAND

NOTE: Always wear ANSI approved safety goggles and work gloves during assembly.

NOTE: The assembly procedures will require the help of additional manpower and a proper lifting device.

1. Set the Stand upside-down on a dry, flat, level floor surface.
(See Figure E.)
2. Slide the Shelf between the Stand Legs, making sure the holes in the middle of the Shelf face the rear of the Stand. (The slot in each Stand end is located toward the front.) **(See Figure E and Assy. Diagram, page 37.)**
3. Align each Bolt hole in the ends and back of the Shelf with the hole located in the middle of each end of the Cabinet.
(See Figure E and Assy. Diagram, page 37.)
4. Insert a Screw through each hole, and secure with a Washer and a Nut.
(See Figure E and Assy. Diagram, page 37.)

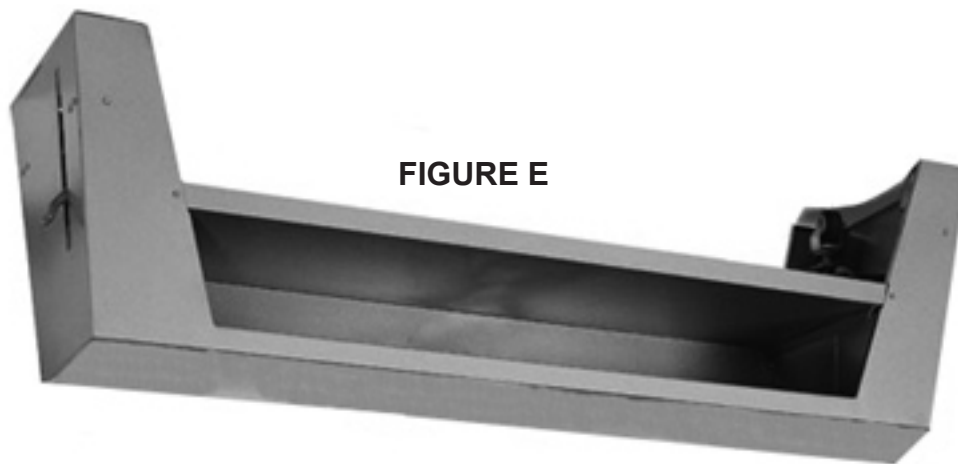

FIGURE E

TO INSTALL THE CASTERS

1. Position the left Caster with its Foot Wheel (109), used to raise the Stand, oriented outward from the Cabinet. Then secure the Caster to the Cabinet, using the Hex Head Screws.
(See Figure F, next page and Assy. Diagram, page 37.)
2. Position the right Caster with its foot lever oriented outward from the Cabinet. Then secure the Caster to the Cabinet, using the Hex Head Screws.
(See Figure F, next page and Assy. Diagram, page 37.)
3. Place the Stand into the upright position.

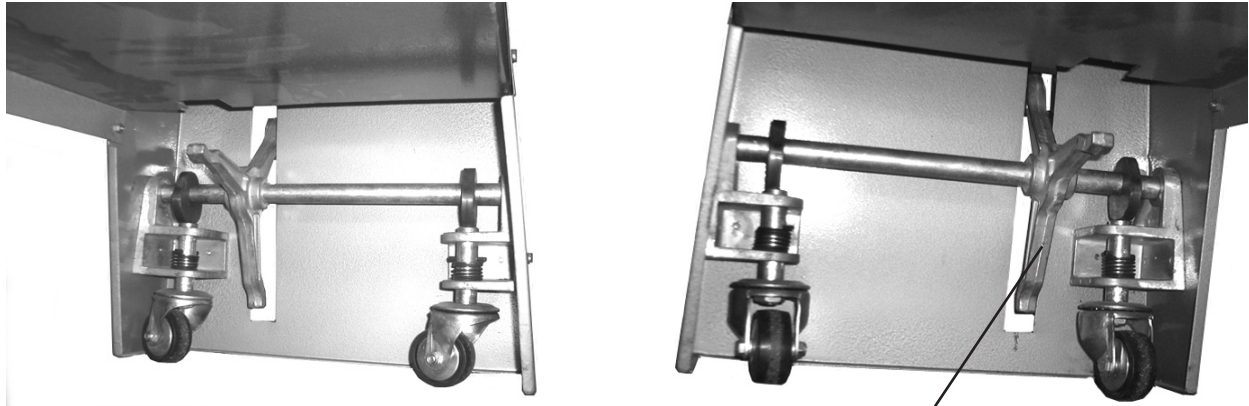

FIGURE F

Foot Wheel (109)

TO MOUNT THE MACHINE ONTO THE STAND

1. Attach the Support Bracket to the Stand, using four Hex Head Bolts, four Spring Lock Washers, and four Hex Nuts. **(See Figure D and Assy. Diagrams, pages 37, 39.)**
2. Step on the Footwheels to lower the Casters. Then move the Stand parallel to the Machine. Step on the Footwheels twice more to raise the Casters to keep the Stand from moving. **(See Figure G and Assy. Diagrams, pages 37, 39.)**
3. With assistance and a proper lifting device, lift the Machine onto the Stand.
4. Attach the Tailstock Support Bracket to the Stand. **(See Figure G and Assy. Diagrams, pages 37, 39.)**
5. Remove the two shipping Bolts, and install the two Lock Knobs on the Powerhead Support Bracket. **(See Figure G and Assy. Diagrams, pages 37, 39.)**
6. Install the Lock Knob on the Tailstock Support Bracket. **(See Figure G and Assy. Diagrams, pages 37, 39.)**

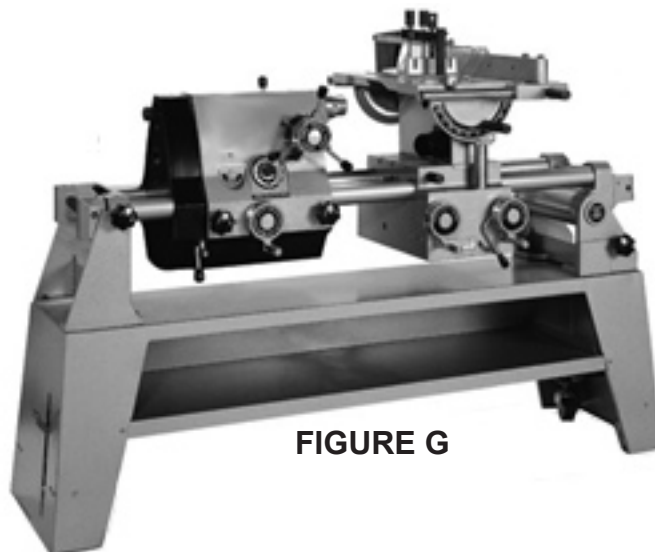
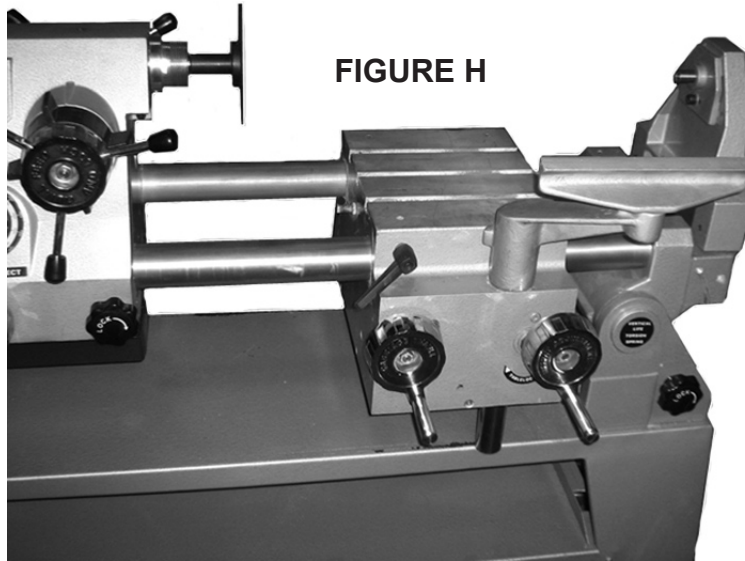

FIGURE G

TO ASSEMBLE THE LATHE TOOL REST

Insert the Tool Rest Post into the Arm. Then tighten the Socket Setscrew using an Allen Wrench (not included). (See Figure H and Assy. Diagrams, pages 44, 55.)



TO ATTACH A SAW BLADE TO THE ARBOR

1. Insert the 3/4" Collet into the Spindle. Rotate the Collet until you feel its Keyway slot engages the Spindle Key.
(See Figure I, next page and Assy. Diagram, page 42.)
2. Insert the Drawrod into the Powerhead, and rotate the Drawrod until it catches the threads of the Collet. **(See Figure I, next page and Assy. Diagram, page 42.)**
3. Insert the Saw Arbor into the Collet, and tighten the Drawbar to secure the Arbor in the Collet. **(See Figure I, next page and Assy. Diagram, page 42.)**
4. With the Saw Teeth pointing toward the front of the Powerhead (toward the operator), place the Saw Blade on the Arbor. Then place the Spacer on the Arbor.
(See Figure I, next page and Assy. Diagram, page 42.)
5. Install the Nut on the Arbor, and firmly tighten with a wrench.
(See Figure I, next page and Assy. Diagram, page 42.)

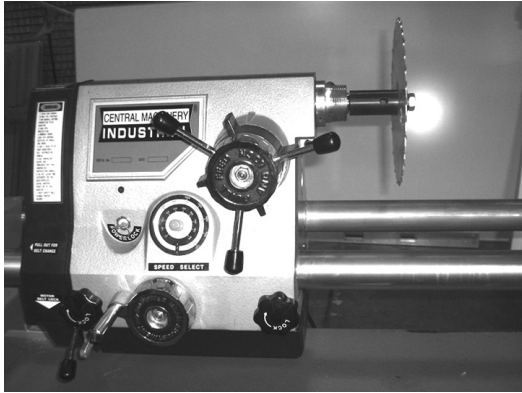
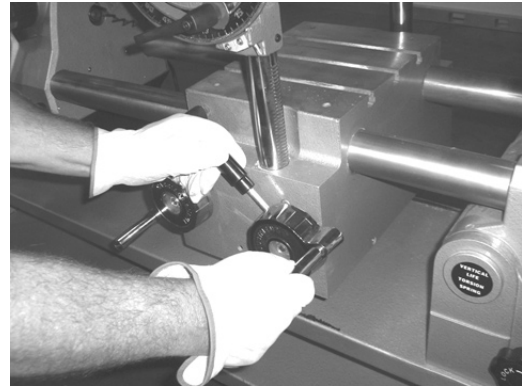

FIGURE I



TO INSTALL THE LOWER BLADE GUARD

1. Position the opening of the Lower Blade Guard under the Saw Blade.
(See Figure J and Assy. Diagram, page 48.)
2. Secure the Lower Blade Guard in place, using the T-Bolt and Wing Nut.
(See Figure J and Assy. Diagram, page 48.)

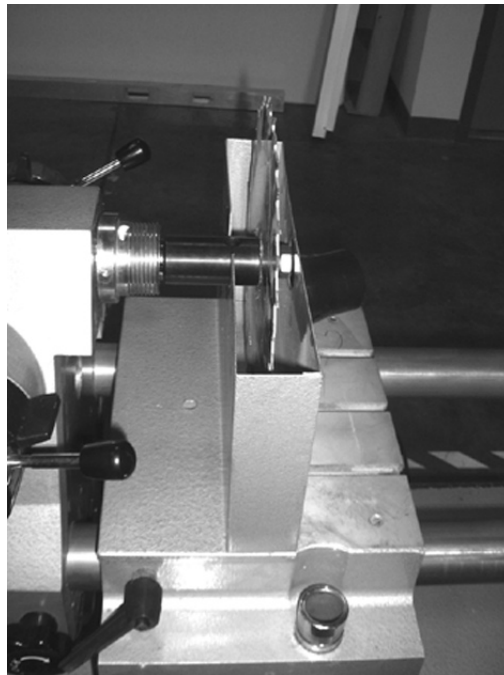

FIGURE J

TO ASSEMBLE THE MAIN TABLE

1. Set the Table upside down with the Trunnion and its degree scale toward you. (See Figure K and Assy. Diagram, page 46.)
2. Install the second Trunnion Lock and Washers from the provided Accessory Pack. (See Figure K and Assy. Diagram, page 46.)
3. Loosen the Table Setscrews and insert the Legs into the Saw Table with the rack teeth facing left. (See Figure K and Assy. Diagram, page 46.)
4. Finger-tighten the Setscrews. The Screws will hold the Legs in the casting, but will be loose enough for final adjusting. (See Figure K and Assy. Diagram, page 46.)

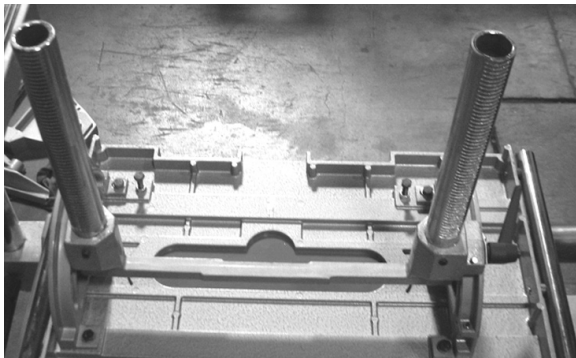
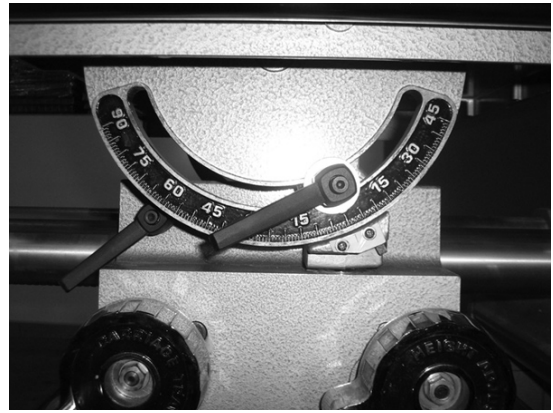
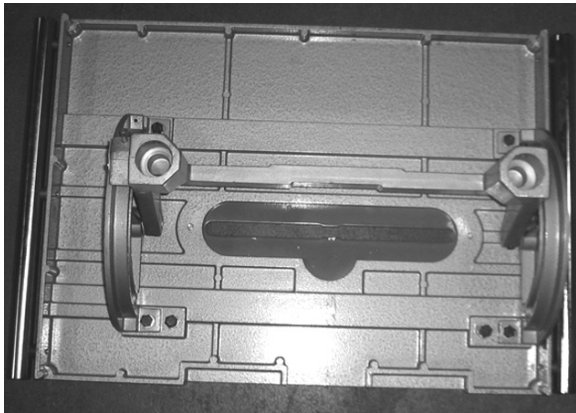
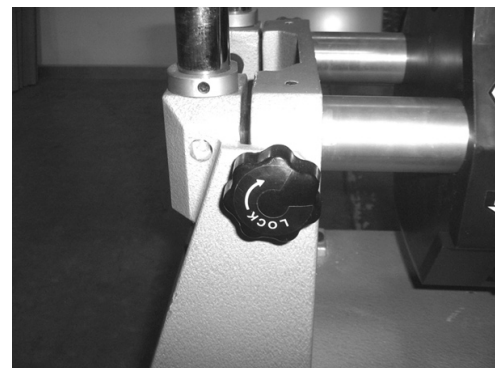

FIGURE K



5. Insert the assembled Table into the Carriage.
(See Figure K and Assy. Diagram, page 46.)
6. Hold the Table Lock Lever up and rotate the Table height Adjustment Hand Wheel counterclockwise to position the Table. Then lock the Table at the desired height by pushing the Table Lock Lever down. **NOTE:** Always use the Table Lock Lever to secure the Table. **(See Figure K and Assy. Diagram, page 46.)**
7. Firmly tighten the Setscrews.
(See Figure K and Assy. Diagram, page 46.)

TO INSTALL THE EXTENSION TABLE

1. Set the Extension Table upside down.
2. Loosen the Setscrews and insert the Legs into the Extension Table. Then, retighten the Setscrews.
3. Loosen the Hand Twist Lock, and insert the Legs of the Extension Table into the mounting holes in the Machine. **(See Figure L and Assy. Diagram, page 52.)**
4. Set the Extension Table to the desired height. Then tighten the Hand Twist Lock to secure the Extension Table in place.
(See Figure L and Assy. Diagram, page 52.)

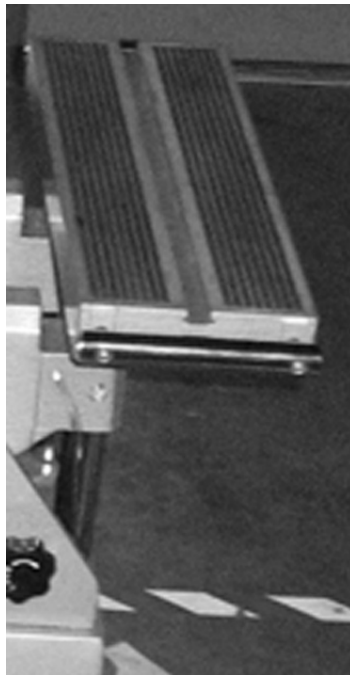

FIGURE L

TO INSTALL THE RIP FENCE AND TOP GUARD

1. Slide the Rip Fence onto the front and back Tubular Guides, and align the Rip Fence with the edge of a table slot. Then tighten the front Lock. **(See Figure M and Assy. Diagram, page 50.)**
2. Align the mounting hole at the rear of the Top Guard with the threaded mounting hole at the rear of the Table. Then tighten the Handle to secure the Top Guard in place. **(See Figure M and Assy. Diagram, page 50.)**

FIGURE M



TO INSTALL THE MITER GAUGE

Remove the Knurled Knob from the mounting post on the Miter Gauge. Slip the Clamp into the slot on the Miter Gauge Handle. Then, reinstall the knurled Knob. Make sure to screw the knurled Knob down through the Clamp to hold it in place. **(See Figure N and Assy. Diagram, page 56.)**

FIGURE N

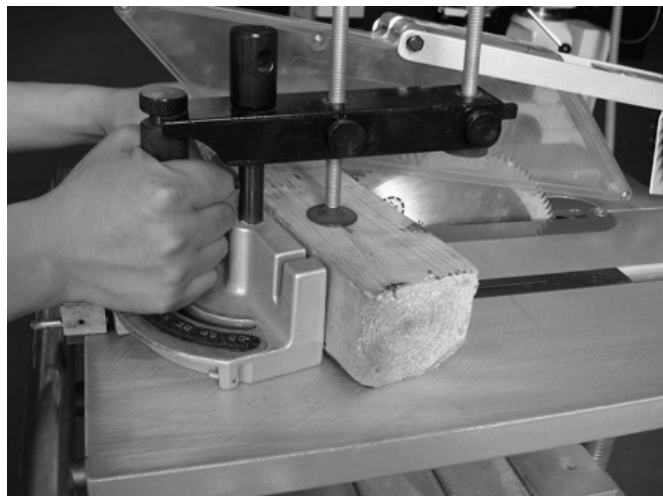

TO INSTALL THE DISC SANDER

1. Insert the Sanding Disc Arbor into the Collet, and insert the Collet into the Quill. Then tighten the Drawrod. Move the saw Table to about 1/16" from the sanding surface. Adjust the height of the Table to about 1" below the centerline of the Disc Sander. **(See Figure O and Assy. Diagram, page 53.)**
2. **NOTE:** If your workpiece requires beveled sanding, tilt the Table to the desired angle. Then adjust the Table's inside edge height so that it is still about 1" below the centerline of the Disc Sander. **(See Figure O and Assy. Diagram, page 53.)**

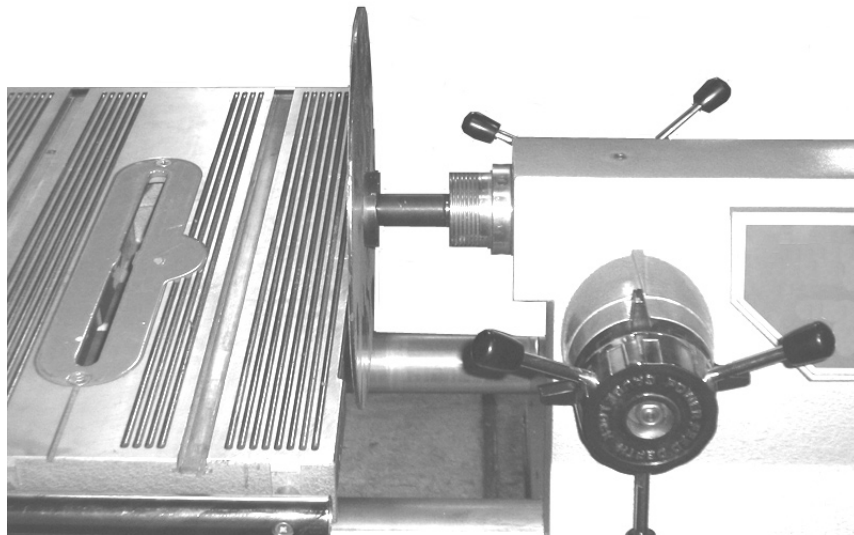

FIGURE O

TO SET UP THE VERTICAL DRILL PRESS

1. Mount the saw Table and tilt it 90 degrees. Move the Powerhead and Carriage into the approximate positions you will need for the drilling task at hand. Then lock the Powerhead and Carriage in place. **(See Figure P, next page.)**
2. Loosen the two Locking Knobs on the Powerhead Support Bracket. Lift the machine into the vertical Drill Press position. Firmly tighten the Vertical Locking Knob on the Tailstock Support Bracket. **(See Figure P, next page.)**
3. Remove the saw blade table Insert and install the drill Insert. Adjust the Powerhead and/or Carriage to the exact position you need. Then, make sure to retighten all Locking Knobs. **(See Figure P, next page.)**
4. **CAUTION!** When moving the Powerhead or Carriage while the machine is in the vertical position, make sure to hold the Travel Knob while loosening the Locking

Knobs. Failure to do so could cause the Powerhead and/or Carriage to drop down along the Way Tubes, causing possible personal injury and/or damage to the machine.

5. Mount the Drill Chuck by inserting it into the 3/4" Collet. Then tighten the Drawrod.
6. **IMPORTANT:** Never allow the Drill Bit to drop, plunge or cut more than 2" below the drill Insert hole. There is a Support Bar just under the Table surface.

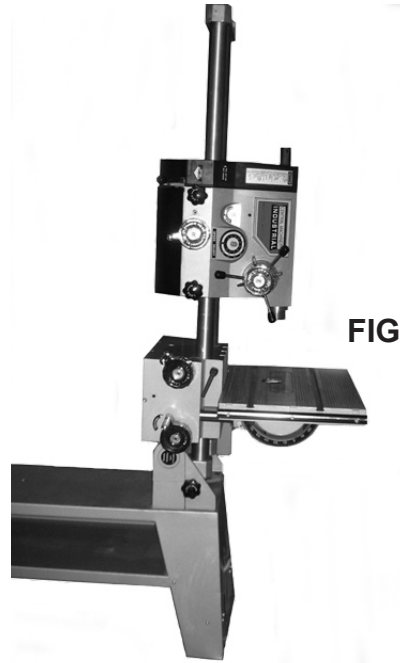

FIGURE P

TO SET UP THE HORIZONTAL BORING TOOL

1. Insert the Drill Chuck (mounted on its Arbor) into the Quill and tighten the Drawrod. Then position the Table below the drill center and move the Table and Carriage toward the Powerhead. (See Figure Q.)

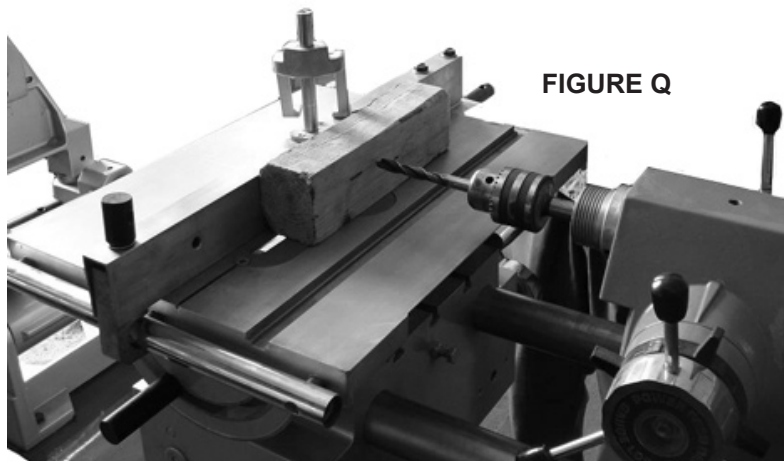

FIGURE Q

2. Use the Rip Fence and/or the Miter Gauge to support and guide the workpiece.
NOTE: Make sure to lock the Miter Gauge in place by tightening the Setscrew in the Guide Bar. **(See Figure Q.)**
3. Set the boring depth by adjusting the Depth Gauge on the Quill Feed.
(See page 16.)

TO SET UP THE SHAPER

1. Install the R8 Collet (653) and draw it in using the Draw bar (SS742). Insert the Shaper Arbor (661) into the R8 Collet. Attach a shaper cutter (not included) using the assembly shown below, making sure to use the Round Guard (665). **(See Figure R below and page 54 parts list and diagram)**
2. Tighten the end Nut (664) and the Rod (647) to secure the assembly. **(See Figure R and page 53)**
3. Raise the Table or extend the Quill until you have the desired depth then tighten the Quill Feed Lock.

Figure R

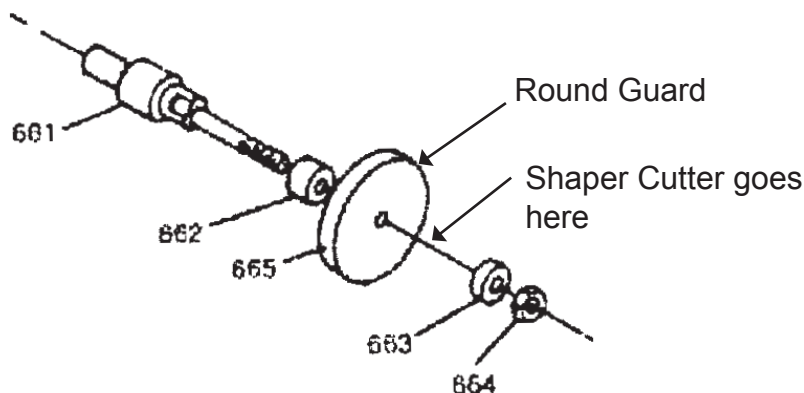

TO SET UP THE ROUTER

1. The Router setup is the same as the Shaper except that you will need a different Collet and Guard.
2. Use the appropriate size Collet (normally 1/2") and Guard. Insert the Collet in the Spindle. Tighten the Collet with the Drawbar a few threads. Then insert the Router Bit in the Collet and tighten.
3. Extend the Quill and lock it in place. Slide the Router Guard over the Quill. Once you have adjusted the cutting depths lock the Guard in place. **(See page 29)**
4. Always feed the workpiece into the Router Bit's rotation (left to right).

INSTALLING AND USING THE CUTTER GUARD

1. This machine comes with a Cutter Guard (800) that can be used with the router, shaper or drilling operations. To attach the guard lower and lock the quill to the desired height. Press the Cutter Guard (800) up onto the quill. Tighten it in place using the nut and bolt pre-installed into the guard. (See Figure 1 below)
2. The guard can be pulled up out of the way when needed. (See Figure 2 below)

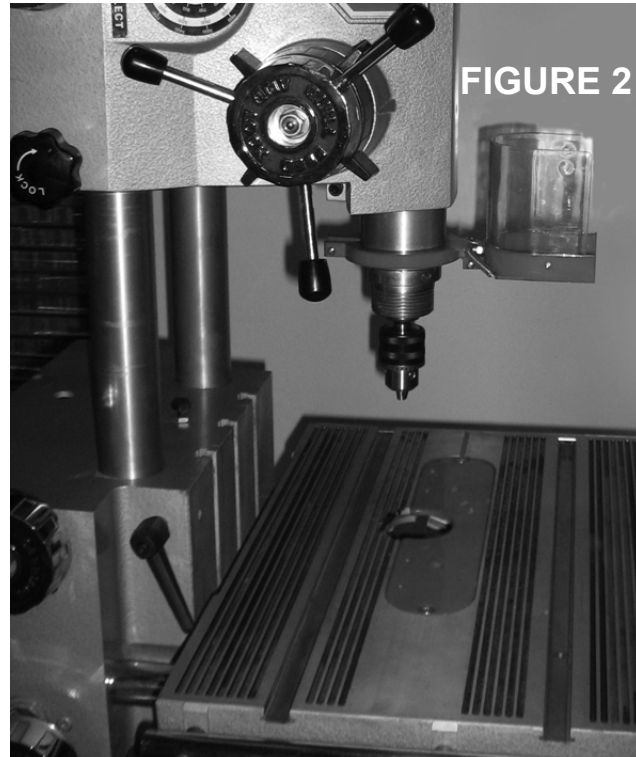
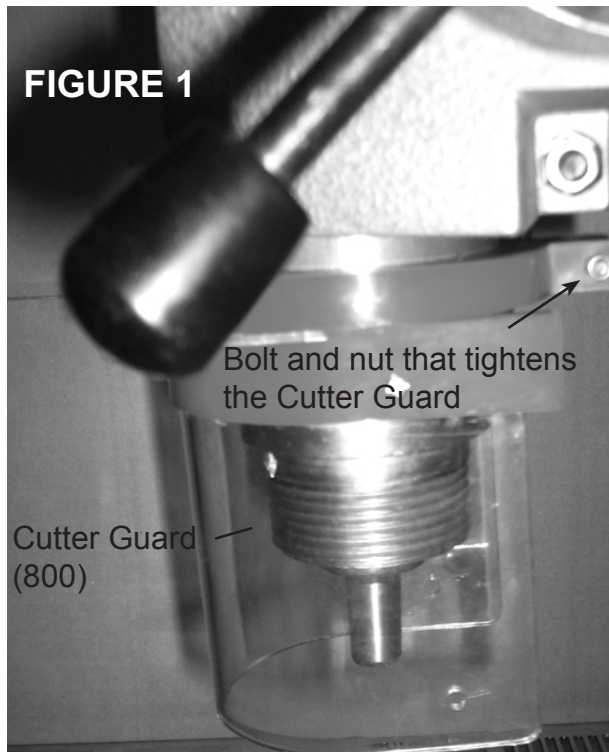

TO SET UP THE LATHE

1. Insert the Lathe Spur Drive Center in the 3/4" R-8 Collet. Insert the Collet into the Quill, and tighten the Drawrod.
2. Insert the Tailstock into the mounting holes on the right of the machine. Lower the Tailstock to its lowest position until the Tailstock Collars touch the Support Bracket. Tighten the Hand-Twist Lock between the posts to secure the Tailstock. Then place the Morse Taper #2 Cup Center in the Tailstock to support the workpiece at the Tailstock end.
3. To mount the workpiece, lock the Powerhead and advance the Quill Feed to engage the workpiece between the Lathe Spur Drive Center and Cup Center. After firmly seating the workpiece between the Spur Drive and Cup Center, relax the Quill slightly and lock the Quill Feed.

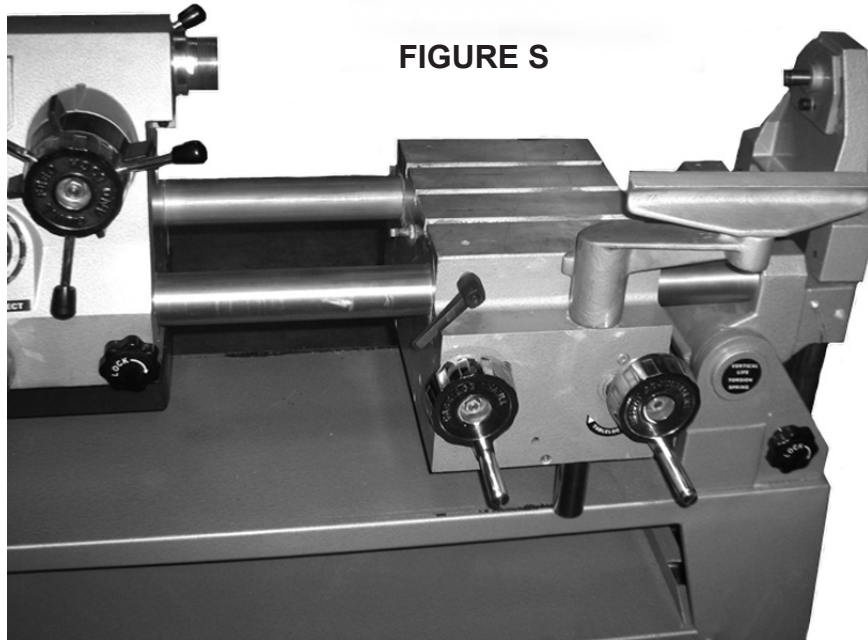

MACHINE ADJUSTMENT INSTRUCTIONS

TO ADJUST THE TORSION SPRING TENSION

1. Move the Carriage and Powerhead all the way to the right end of the Way Tubes and lock them in place.
2. Loosen the Way Tube's Locking Knobs. Make sure the Way Locks on the Carriage and Powerhead are securely tightened.
3. Lift the Way Tubes, Carriage, and Powerhead to the vertical Drill Press position. Then lock the vertical Locking Knob.
4. Locate the Pivot Hub on the back of the Metal/Woodworking Machine opposite the Vertical Lock Knob. Look into the holes in the Pivot Hub. You should observe part of the holes drilled in the base showing through.
5. Use the Spanner Wrench provided to rotate the Pivot Hub counterclockwise until the slack is taken up. Continue turning the Wrench counterclockwise until a set of holes in the Pivot Hub line up. Install all three Socket Head Capscrews and tighten. (The numbers shown in Figure T are for your reference and do not appear on the Metal/Woodworking Machine.)
6. Make sure to first tension the Spring at one hole in the Pivot Hub, install and tighten the Bolts, and then test by lowering and lifting the Powerhead. If you desire still more tension for easier lifting, rotate the Pivot Hub one more set of holes counterclockwise.

7. Only tension two holes if necessary. Overtensioning the Spring can cause personal injury and/or damage to the Machine.
8. **CAUTION!** Once the Torsion Spring has been tensioned, DO NOT remove the Torsion Spring Base from the Stand without first relieving tension on the Spring. Failure to do so can result in personal injury and/or damage to the Machine. (See Figure T.)

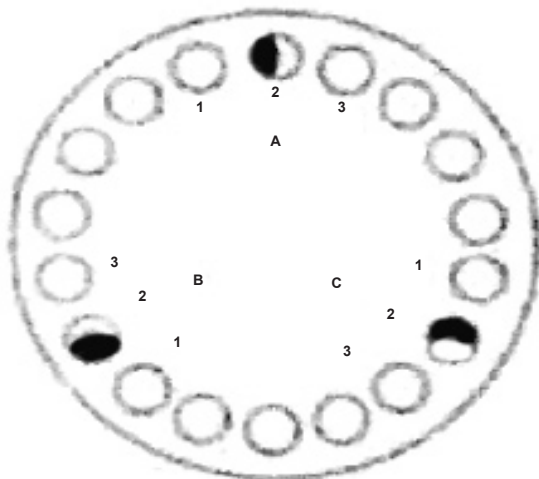

Torsion Spring with slack removed

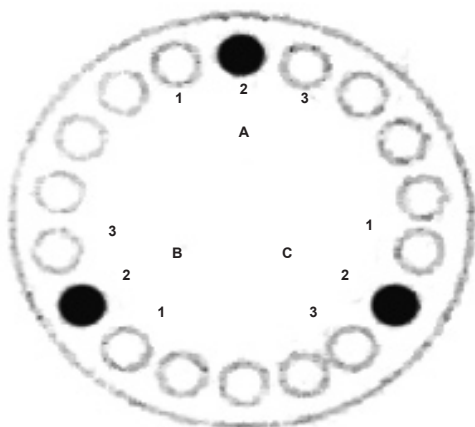

Less Torsion

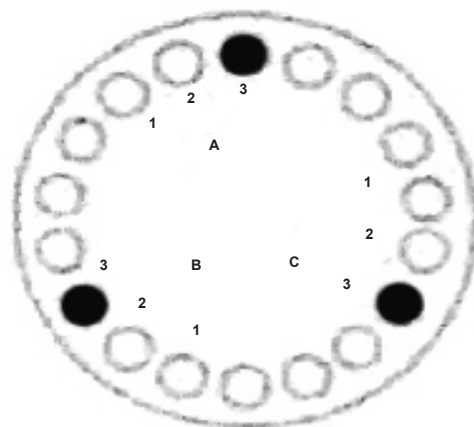

More Torsion

TO ALIGN THE SAW TABLE TO THE SAW BLADE

1. Set up the machine with the Table in place and the Saw Blade/Arbor installed.
2. Set the Table Trunnion to zero.
3. Place the Miter Gauge in the Table Slot closest to the Saw Blade.
4. Hold a pencil against the face of the Miter Gauge while touching the face of the Saw Blade. As you rotate the Saw Blade, the high spot on the Blade will push the pencil away. Mark the high spot with chalk or a felt marker.
5. Reposition the pencil, the Miter Gauge, and the high spot on the Saw Blade together at the infeed end of the Table.
6. Rotate the Saw Blade, and bring the Miter Gauge and the high spot together at the infeed end of the Table. Make sure to keep the pencil in the same spot against the Miter Gauge.
7. The Table is aligned if the pencil tip touches the Saw Blade with the same touch and in the same place all the way around the Blade. The Table is not aligned if the Saw Blade pushes the pencil or there is a gap between the pencil tip and Blade. If the Table is not aligned, loosen all four Capscrews attaching the Table to the Trunnions. Adjust the Table. Then repeat Steps #2, #3, #4, #5, #6. Once alignment is achieved, tighten all four Capscrews.

TO ALIGN THE SAW TABLE 90 DEGREES TO THE SAW BLADE

1. Hold a T-Square on the Table and against the Saw Blade with the high spot 90 degrees from the T-Square. Make sure the T-Square does not touch the Saw Blade teeth.
2. If the Table is not 90 degrees to the Saw Blade loosen the front and back Trunnion Handles.
3. Move the Table enough so the T-Square's two edges are flush with both the Table and Saw Blade.
4. Use Phillips screwdriver to reset the Trunnion's 0 Degree Indicator to zero.
5. Loosen the Trunnion Locks and slightly move the Table. If the Table does not automatically stop at 0 degrees use a small screwdriver to adjust the Setscrew stop. The Table should stop at 0 degrees each time.

TO ADJUST THE SAW TABLE'S 45 DEGREE STOP

1. Loosen the Trunnion Handle and move the Table toward 45 degrees.
2. Push on the Auto Stop Pin. If the Table does not stop at 45 degrees, move the Table back toward 0 to allow room to adjust the 45 Degree Stop Pin.
3. Make a slight adjustment to the Stopscrew and recheck the Stop. Repeat this procedure until it stops at exactly 45 degrees.

TO ALIGN THE MITER GAUGE

1. Place the Miter Gauge in the Table Slot closest to the Saw Blade.
2. Place a T-Square against the face of the Miter Gauge and the Saw Blade with the high spot at the top of the Blade.
3. Loosen the Miter Gauge Handle. Then move the face of the Miter Gauge so the T-Square's edges are flush against the Miter Gauge and Saw Blade.
4. Use a screwdriver to reset the pointer to 0 degrees.
5. Pull the Stop Rod out and use a screwdriver to adjust the Stop Rod to 0 degrees.
6. To set the Miter Gauge at 45 degrees, pull out the Stop Rod and rotate the Miter Gauge face 45 degrees. Then place the 45 degree angle between the Miter Gauge face and Saw Blade.
7. When both angle edges are flush with the Miter Gauge face and Saw Blade adjust the 45 Degree Setscrew.
8. Place the Miter Gauge in the channel facing the opposite direction. To set another 45 degree stop, repeat Steps #6 and #7.

TO ALIGN THE EXTENSION TABLE 90 DEGREES TO THE SAW BLADE

1. Remove the saw Table from the Carriage. Move the Carriage and Powerhead all the way to the right.
2. Install the Extension Table with the top just above the Saw Blade Arbor. Then tighten the Handle Clamp.
3. Place the Miter Gauge in the Table Slot. Hold a pencil against the face of the Miter Gauge while touching the face of the Saw Blade. As you rotate the Saw Blade, the high spot will push the pencil away. Mark the high spot with chalk or a felt marker.

4. Place the pencil back in the Miter Gauge and align the pencil point and the high spot together at the infeed end of the Table. Rotate the Saw Blade, and bring the Miter Gauge and the high spot together at the outfeed of the Table.
5. The Extension Table is aligned if the pencil tip touches the Saw Blade just the same touch and place. Make sure all four Hex Head Capscrews attaching the Table are tight.
6. The Extension Table is not aligned if the pencil tip pushes the Saw Blade or there is a gap between the pencil tip and Blade. If the Table is not aligned, loosen all four Capscrews attaching the Table. Once alignment is achieved, tighten all four Capscrews.
7. The Extension Table will now be aligned each time you mount it in the right-hand end of the machine. **NOTE:** The Table may be used on the left-hand end of the machine but will not be aligned with the Saw Blade. Mounting the Extension Table on the left-hand side of the machine is for extra support only.

TO SET THE CARRIAGE BUMPER BOLT

1. With the Saw Blade mounted and the Quill fully retracted, bring the Powerhead and Carriage together until they touch.
2. Install the saw Table on the Carriage.
3. Lower the Table, and look down through the Saw Blade Insert and move the Carriage left or right as needed to center the Blade in the Saw Insert Slot.
4. Once the Table is centered over the Saw Blade, lock the Powerhead and Carriage onto the Way Tubes.
5. Adjust the Carriage Bumper Bolt on the Carriage so that it just touches the side of the Powerhead. Then tighten the Locking Nut against the Carriage Casing.
6. Now each time the Table Saw is set up, the Saw Blade will be centered in the saw Table Insert Slot.

TO ALIGN THE SAW TABLE 90 DEGREES TO THE POWERHEAD

1. Move the Powerhead about 10" from the Carriage.
2. Install the saw Table and Drill Chuck/Drill Bit in the Horizontal Boring Tool.
3. Loosen the Table Trunnion Locks. Then tilt the Table 90 degrees and tighten the Locks.
4. Place a T-Square against the Drill Bit and Table surface.

5. If the Table is not perfectly squared with the Drill Bit, adjust the Table Stops with a wrench.
6. Recheck the Table's 90 degree setting, and correct as needed.

TO ALIGN THE LATHE TAILSTOCK WITH THE POWERHEAD

1. Install the Drill Chuck/Drill Bit in the Horizontal Boring Tool. Make sure the Drill Bit is straight and long.
2. Remove the saw Table and Extension Table from the machine. Then mount the Tailstock with the Tail Center installed.
3. With the Drill Bit tip and Tail Center almost touching, check their alignment.
4. To vertically align the Drill Bit and Tail Center, raise or lower the Tailstock. Once aligned, loosen, position, and tighten the Collar.
5. To horizontally align, use an allen wrench to loosen the Socket Head Capscrew. Move sideways for alignment. Then retighten.

SPEED CHART

	HARDWOOD	SOFTWOOD	
TABLE SAWING	3200-3600 RPM	3200-3600 RPM	
DISC SANDING Use Lowest Pulley Range			
Course	800-900 RPM	800-900 RPM	
Medium	700-800 RPM	700-800 RPM	
Fine	600-700 RPM	600-700 RPM	
DRILLING & HORIZONTAL BORING			
Size of Hole:			
Under 0.236"	2700-3000 RPM	3300-3600 RPM	
0.236"-0.472"	2400-2700 RPM	3000-3300 RPM	
0.472"-0.708"	2100-2400 RPM	2500-3000 RPM	
0.708"-0.984"	1700-2100 RPM	2000-2500 RPM	
Over 0.984"	Under 900 RPM	Under 900 RPM	
ROUTER/SHAPER	7200 RPM	7200 RPM	
LATHE TURNING			
Size of Stock:	Rough	Finish	
Under 1.968" Diameter	800-900 RPM	2000-2400 RPM	
1.968"-3.937"	700-800 RPM	1800-2000 RPM	
3.937"-5.905"	600-700 RPM	1600-1800 RPM	
Over 5.905"	500-600 RPM	800-900 RPM	
METAL			
Metal Cutting Speed Formula: $N=12V/\pi D$ N = Spindle Speed (RPM) V = Max. Cutting Speed from Chart at Right D = Diameter in Inches For turning, use outside diameter. For milling/drilling or reaming, use Cutter Diameter $\pi = 3.14$	Material	HSS Cutters	Carbide Cutters
	Aluminum	700	1000
	Brass	200	700
	Bronze & Copper	120	300
	Magnesium	700	1200
	Soft Steel	90	400
	Medium Steel	70	250
	Hard Steel	40	150
	Stainless Steel	70	250
	Gray Iron	50	150
Malleable Iron	100	250	

PARTS LISTS AND DIAGRAMS

PARTS LIST - CABINET & CASTERS

Part	Description	Q'ty	Part	Description	Q'ty
101	Cabinet	1	107	Cam Rod	2
102	Caster Fitting, Left	2	108	Cam	4
103	Caster Fitting, Right	2	109	Foot Wheel	2
104	Caster	4	110	Truss-Head Screw (S11304)	12
105	Caster Spring	4	111	Roll Pin (S22275)	4
106	Roll Pin (S22260)	6	736	Shelf	1

ASSEMBLY DIAGRAM - CABINET & CASTERS

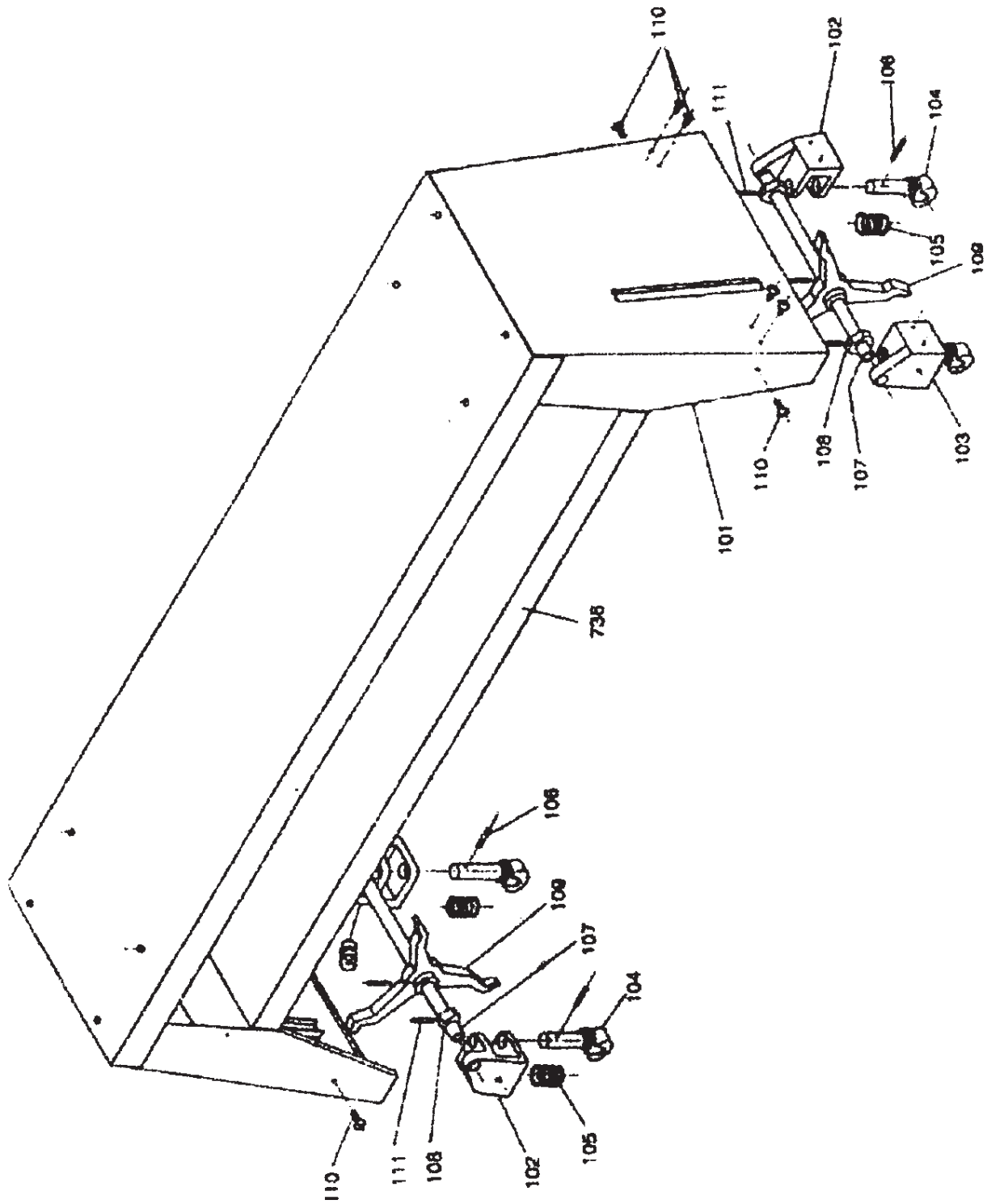

PARTS LIST - MAIN BED

Part	Description	Q'ty	Part	Description	Q'ty
201	Rack	1	213	Lock Knob Assy.	1
202	Tube	1	214	Support Stand	1
203	Tube Spacer	1	215	Handle Clamp	2
204	Socket Setscrew (S12557)	6	216	Screw (Right Hand)	2
205	Tail Pivot	1	217	Screw (Left Hand)	2
206	Pin	1	218	Torsion Spring	1
207	Spacer (Hole)	1	219	Hexhead Capscrew	8
208	Spacer	1	220	Spring Lock Washer	8
209	Hub	1	221	Hex Nut	8
210	Hub (Pivot Hole)	1	222	Lock Knob Assy.	2
211	Sockethead Capscrew (S11340)	3	223	Flat Washer	8
212	Tail Base	1	739	Torsion Spring Tailbase Assy.	1

ASSEMBLY DIAGRAM - MAIN BED

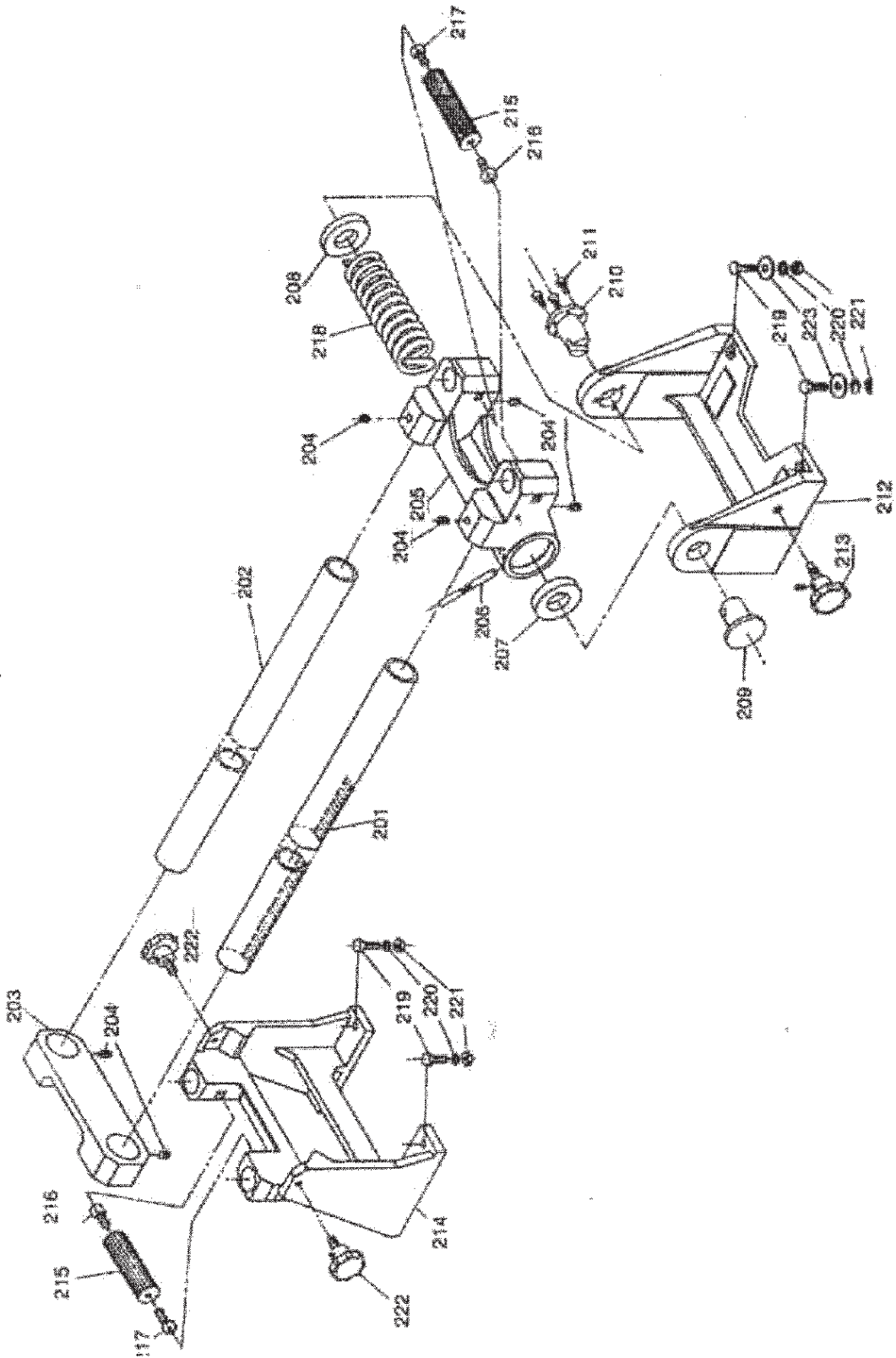

PARTS LIST -Head Assy.

Part	Description	Q'ty	Part	Description	Q'ty
301	Main Head	1	339	Dial Depth Stop	1
302	Pilot Setscrew	1	340	Knob Lock	1
303	Sockethead Capscrew	1	341	Cap Screw	1
304	Hole Plug	1	342	Tapered Knob	7
305	Quill	1	343	Rod Knob Handle	7
306	Bearing	2	344	Quill Feed Knob (Back)	1
307	Snap Ring	1	345	Hex Jam Nut (S18185)	2
308	-----	-----	346	Hole Plug	3
309	Spindle Assy.	1	347	Screw	1
310	Spindle Sleeve	1	348	Gear (20 Tooth)	1
311	Bearing	2	349	Roll Pin (S22260)	1
312	Spacer	1	350	Belleville Washer	1
313	Timing Pulley (Spindle)	1	351	Brake Block	1
314	Socket Setscrew	2	352	Spacer (Spindle Lock)	1
315	Snap Ring	1	353	Brake Block	1
316	Snap Ring	1	354	Quill Feed Knob (Front)	1
317	Timing Belt	1	355	Hex Jam Nut	1
318	Shaft (Main Idler)	1	356	Guard Bottom	1
319	Bearing	2	357	Nut	1
320	Spacer (Idler Shaft)	2	358	Drive Motor (701)	1
321	Snap Ring	1	359	Key	2
322	Socket Setscrew	1	360	Spacer	1
323	Timing Pulley	1	361	Motor Mounting Plate	1
324	Key	1	362	Socket Shoulder Screw	1
325	Key	3	363	Sockethead Capscrew (S11991)	4
326	Hex Jam Nut	1	364	Socket Setscrew	1
327	Idler Sheave	1	365	Locking Stud	1
328	Washer	1	366	Collar	1
329	Nameplate Set	1	367	Knob Assy.	1
330	V-Belt (26")	1	368	Motor Sheave	1
331	Quill Shaft	1	369	Setscrew	4
332	Snap Ring	1	370	Belt Cover	1
333	Drive Screw	1	371	Guide Pin (Short)	1
334	Key	3	372	Guide Pin (Long)	1
335	Key	4	373	-----	-----
336	Shoulder Bolt (Special)	1	374	Lock Torque Knob	2
337	Quill Spring	1	375	Roll Pin	2
338	Brake Depth Stop (Inner)	1	376	Locking Bar (Short)	1

PARTS LIST - head assy. (CONT.)

Part	Description	Q'ty	Part	Description	Q'ty
377	Locking Bar (Long)	1	391	Gear Cluster	1
378	Way Brake Pad (Front)	2	392	Drive Shaft	1
379	Way Brake Pad (Rear)	2	393	Flat Washer	1
380	-----	-----	394	Gear	1
382	Power Head Knob	1	395	-----	-----
384	Cap Screw (S11911)	1	396	Gear	1
385	Thrust Washer	3	397	Rear Gear Plate Assy.	1
386	Shaft Driver	1	398	Flat Sockethead Capscrew	3
387	Qull Assy.	1	428	Handle	1
388	Pinion	1	429	Part of SS428	1
389	Spacer	1	430	Hex Jam Nut (S18155)	1
390	Idler Shaft	1	777	Drive Motor	1
			800	Cutter Guard (not shown)	1

ASSEMBLY DIAGRAM - HEAD ASSY.

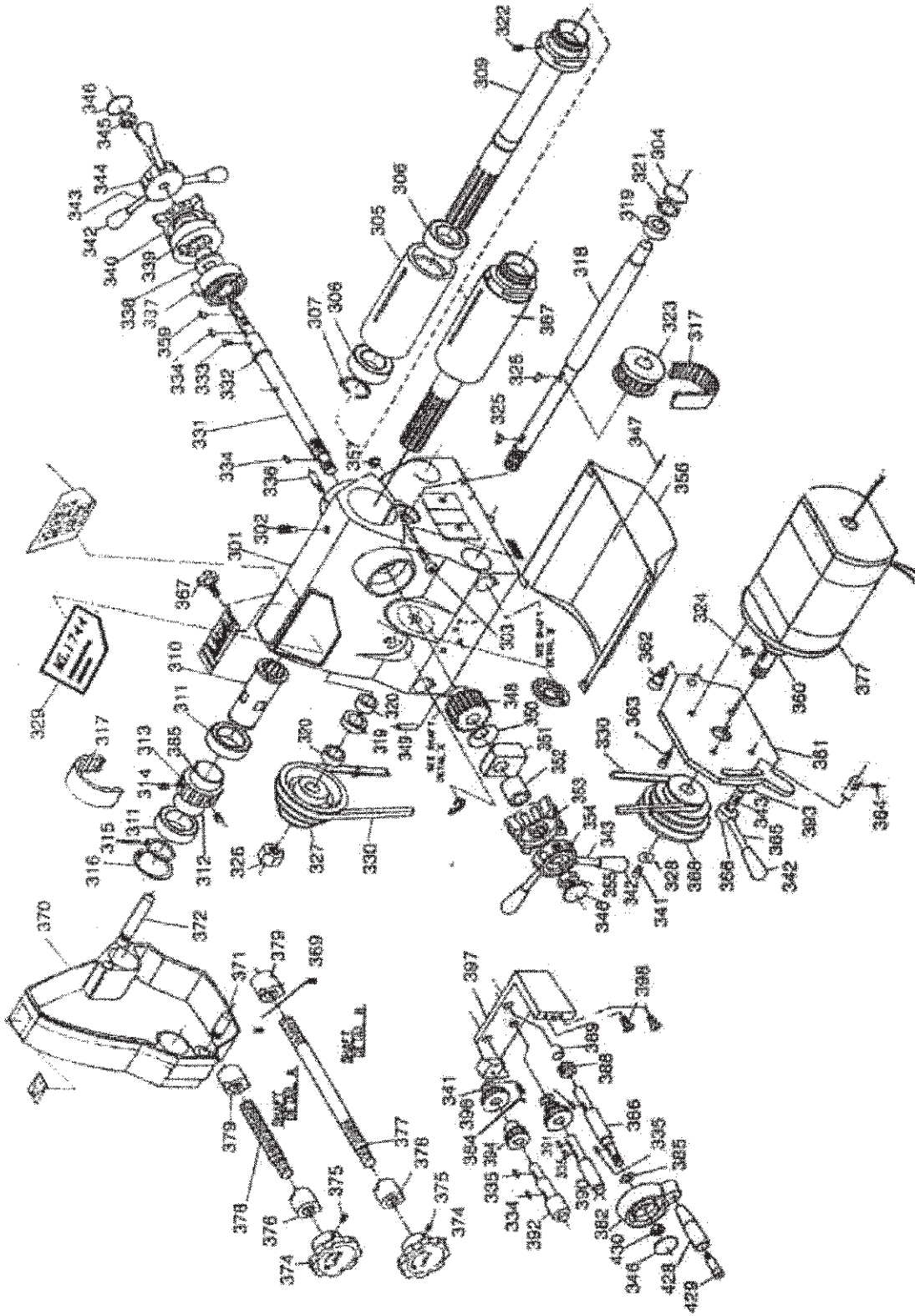

PARTS LIST - CARRIAGE ASSY.

Part	Description	Q'ty	Part	Description	Q'ty
401	Carriage	1	433	Shaft	1
402	Shim Block	1	434	Coupler	2
403	Hexhead Screw	2	435	Gear	1
404	Knob (Height Adjustment)	1	436	Gear	1
405	Carriage Guard	1	437	Snap Ring	2
406	Phillips Flathead Screw	6	438	Key	1
407	PSG Motor Gear	1	439	Shim Washer	6
408	-----	-----	440	Roll Pin (S22250)	5
409	-----	-----	441	Spacer	1
410	Spacer	2	442	Spacer (Short)	1
411	Brake Handle Assy.	1	443	Sprocket	1
412	Roll Pin (S22222)	1	444	-----	-----
413	Stud	1	445	Saw Table Lock Shaft	1
414	Hex Nut	2	446	Brake Pad (Front)	1
415	Gib Tube	2	447	Brake Pad (Rear)	1
416	Gib Collar	1	448	Carriage Lock Assy.	1
417	Gib (Threaded)	1	449	Socket Setscrew	4
418	Gib (Right & Left)	2	450	Washer	1
419	Ball Plunger	1	451	Screw (S11315)	1
420	Shaft	1	452	Shaft	1
421	Pinion	1	453	Pinion	1
422	Spacer	1	454	Roll Pin	2
423	Spacer	1	455	Washer	3
424	Roll Pin	2	456	Gear	1
425	Key	2	457	Shaft	1
426	Washer	2	458	Pinion	1
427	Knob Carriage	1	459	Motor Bracket	1
428	Handle	2	460	Bracket Screws (S11644)	4
429	Shoulder Screw	2	461	Lockwasher	3
430	Hex Nut	2	462	Sockethead Capscrew (S11658)	3
431	Hole Plug	2	463	Roller Chain (08A-1-28)	1
432	Shaft	1	723	Motor Gearhead Assy.	1

ASSEMBLY DIAGRAM - CARRIAGE ASSY.

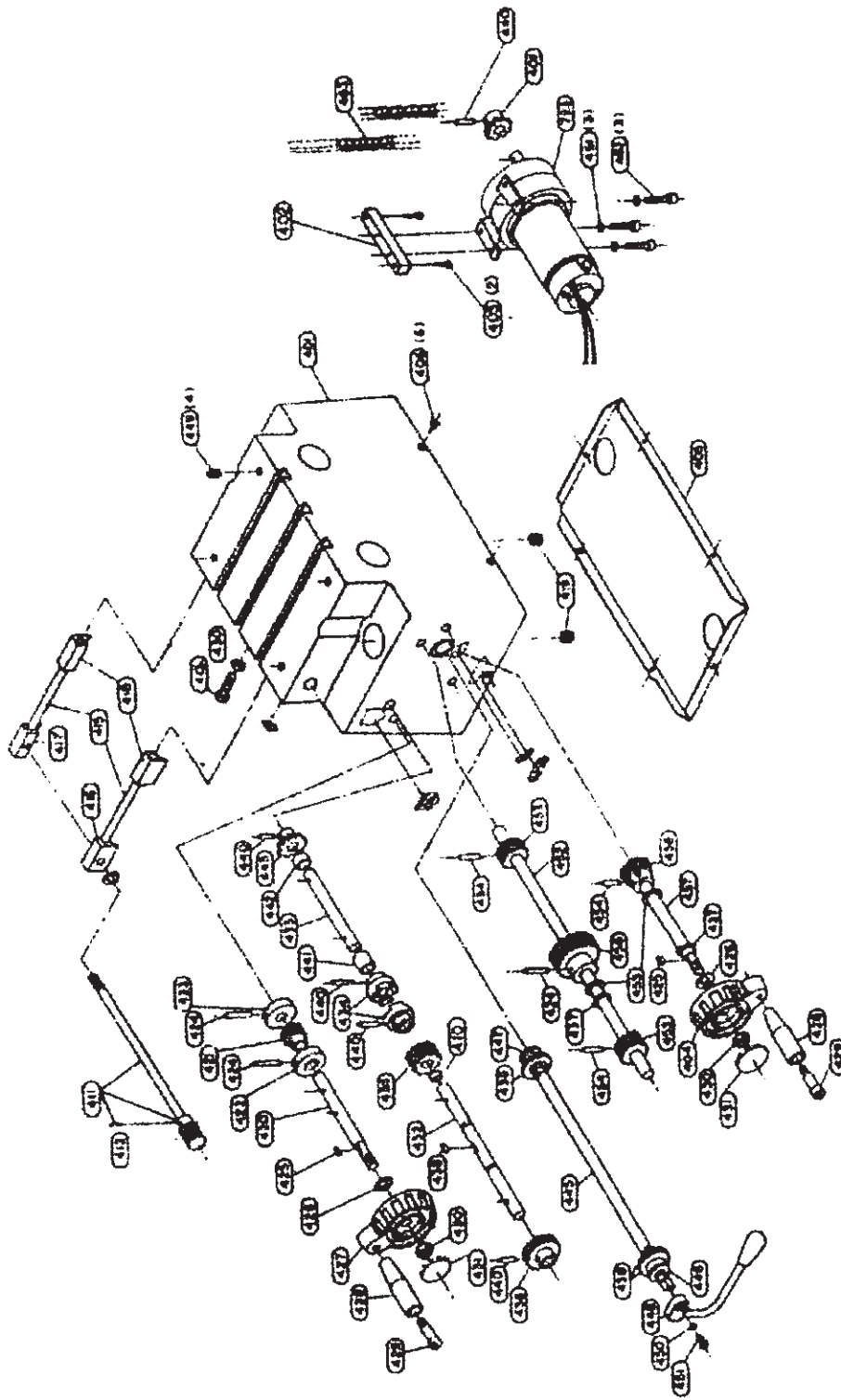

PARTS LIST - SAW TABLE ASSY.

Part	Description	Q'ty	Part	Description	Q'ty
204	Socket Setscrew (S12557)	4	514	Flat Washer	6
501	Saw Table	1	515	Pivot Pin	2
502	Rail Mount	6	516	Handle Assy.	2
503	-----	-----	517	-----	-----
504	Tube Assy. (Plain)	2	518	Saw Table Rack	2
505	-----	-----	520	Saw Table Stand	1
506	Flathead Capscrew	6	521	Saw Blade Insert	1
507	Hex Nut	2	522	Drill Press Insert	1
508	Hexhead Capscrew	2	523	Roundhead Screw	2
509	Trunnion (Front)	1	524	Pivot Indicator	1
510	Trunnion (Rear)	1	526	Stop Pin	1
511	Hexhead Capscrew	4	527	Setscrew	2
512	Spring Lockwasher	4	528	Roller	4
513	Flat Sockethead Capscrew	2			

ASSEMBLY DIAGRAM - SAW TABLE ASSY.

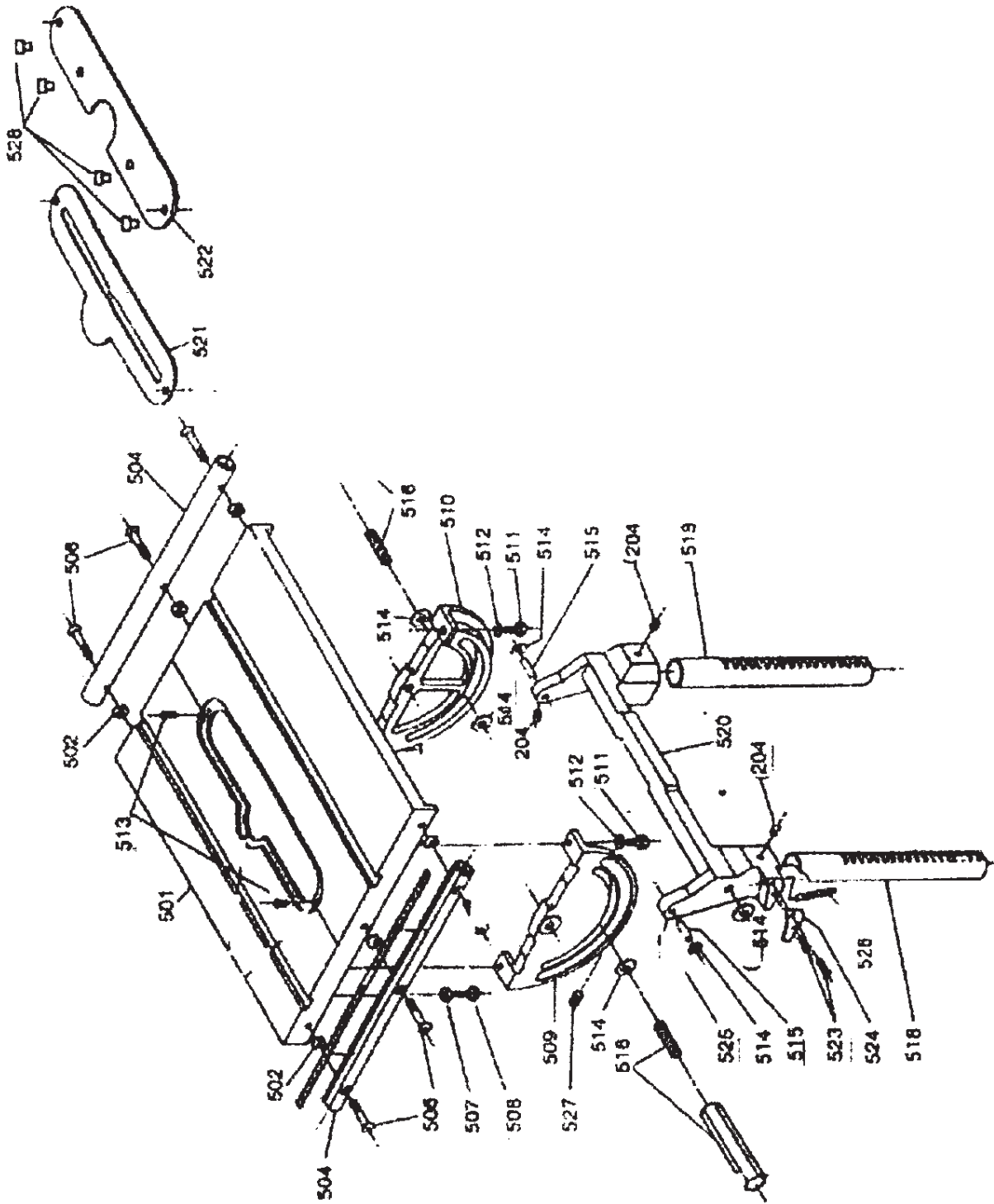

PARTS LIST - SAW GUARD ASSY.

Part	Description	Q'ty	Part	Description	Q'ty
530	Top Guard	1	541	Hex Locknut	2
531	Lower Guard	1	542	Arm Weld Assy.	1
532	T-Bolt	1	543	Flat Washer	1
533	Support	1	560	Flanged Elbow	1
534	Clamp	1	561	Screw	4
535	Roll Pin	1	562	Spacer	2
536	Handle	1	563	Spring	1
537	Knob Assy.	1	564	Finger	2
538	Wing Nut	1	655	Clevis Pin	1
539	Hexhead Capscrew	2	666	Cotter Pin	1
540	Saw Guard Pivot Tube	2			

ASSEMBLY DIAGRAM - SAW GUARD ASSY.

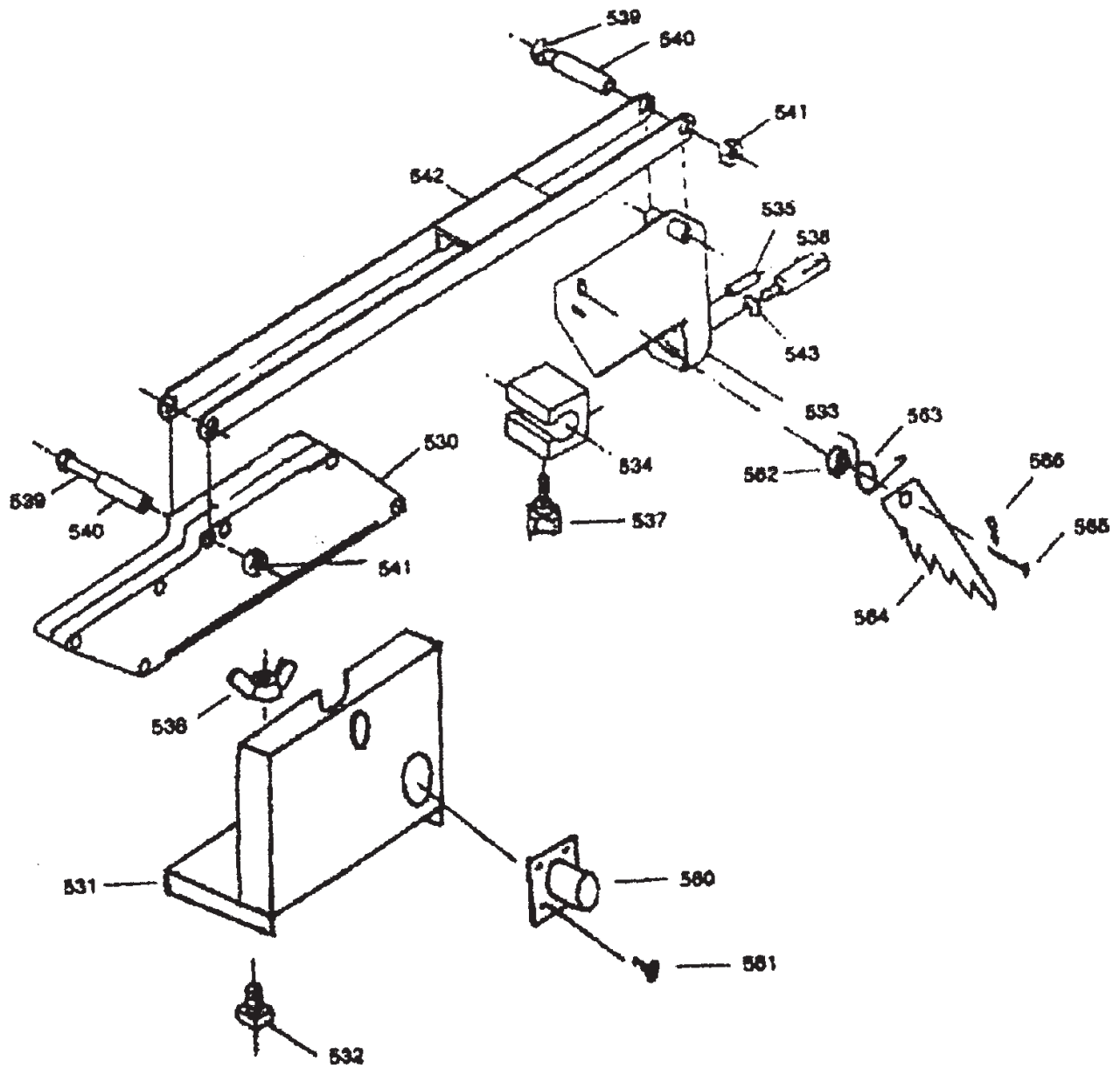

PARTS LIST - RIP FENCE ASSEMBLY DIAGRAM

Part	Description	Q'ty	Part	Description	
550-1	Guide Assy.	1	551-12	Rail Assy.	1
550-2	Guide Assy.	1	552-7	Catch Block Assy.	1
550-3	Guide Assy.	1	552-8	Catch Block Assy.	1
550-4	Guide Assy.	1	553-1	Handle Assy.	1
551-5	Rail Assy.	1	553-12	Handle Assy.	1
551-6	Rail Assy.	1	554	Whiz-Lock Hexhead Capscrew	2
551-9	Rail Assy.	1	555	-----	----
551-10	Rail Assy.	1	556	Socket Setscrew	1
551-11	Rail Assy.	1			

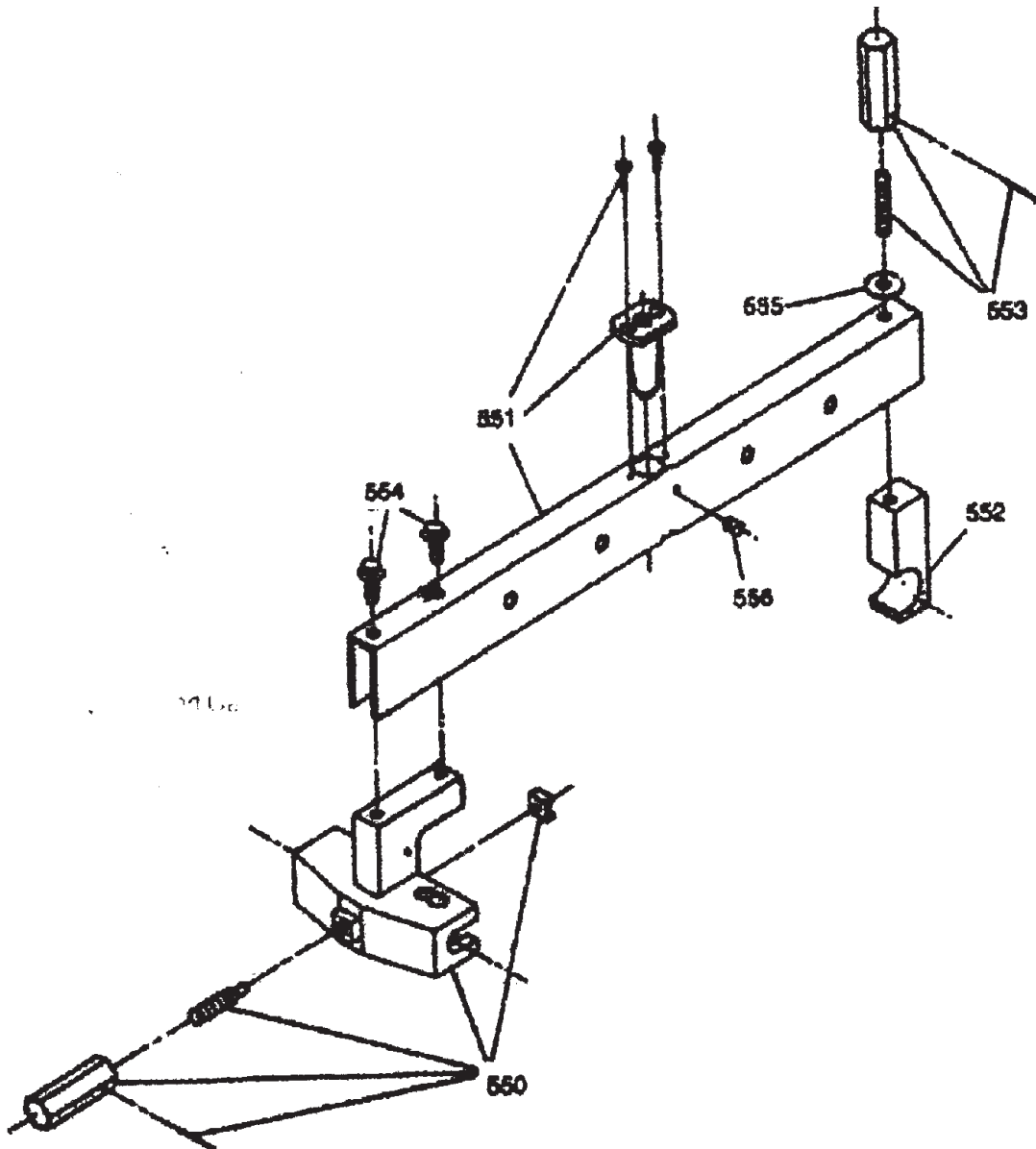

PARTS LIST & ASSY. DIAGRAM - LATHE TAILSTOCK ASSY.

Part	Description	Q'ty	Part	Description	
204	Socket Setscrew (S12557)	6	625	Collar	2
622	Tailstock	1	626	Center Cup	1
623	Post	2	628	Sockethead Capscrew	1
624	Tool Retainer	1	629	Flat Washer	1

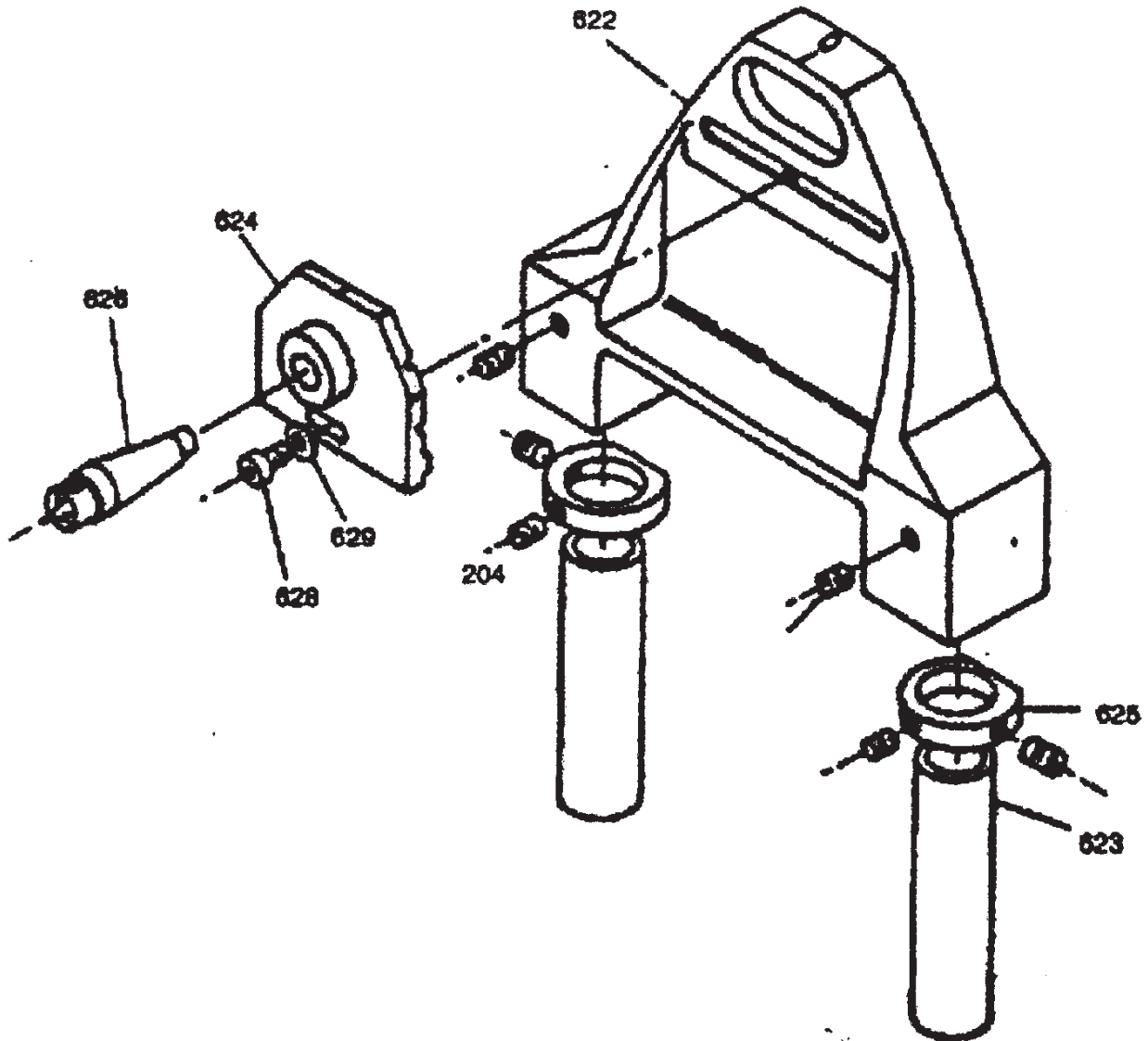

PARTS LIST & ASSY. DIAGRAM - EXT. TABLE ASSY.

Part	Description	Q'ty	Part	Description	Q'ty
601	Extension Table	1	606	Post	2
602	Extension Table Mount	1	204	Socket Setscrew (S12557)	2
603	Hexhead Capscrew	4	608	Rail Mount	4
604	Spring Lockwasher	4	609	Tube	2
605	Flat Washer	4	610	Flat Sockethead Capscrew	4

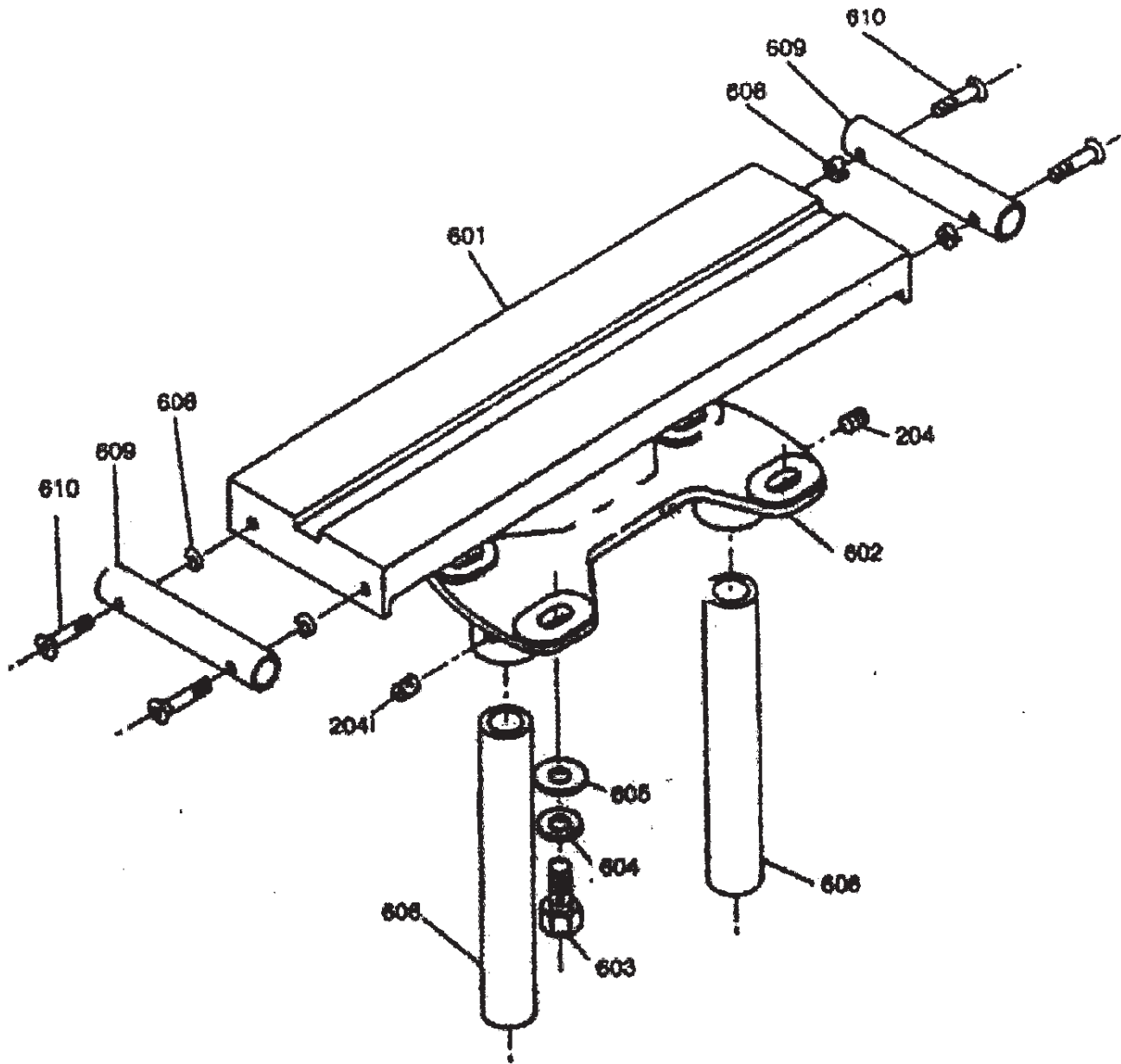

PARTS LIST & ASSY. DIAGRAM - SANDING DISC ASSY.

Part	Description	Q'ty	Part	Description	Q'ty
640-2	Disc	1	642	Sanding Paper (12")	1
641-0	Sanding Disc Hub	1			

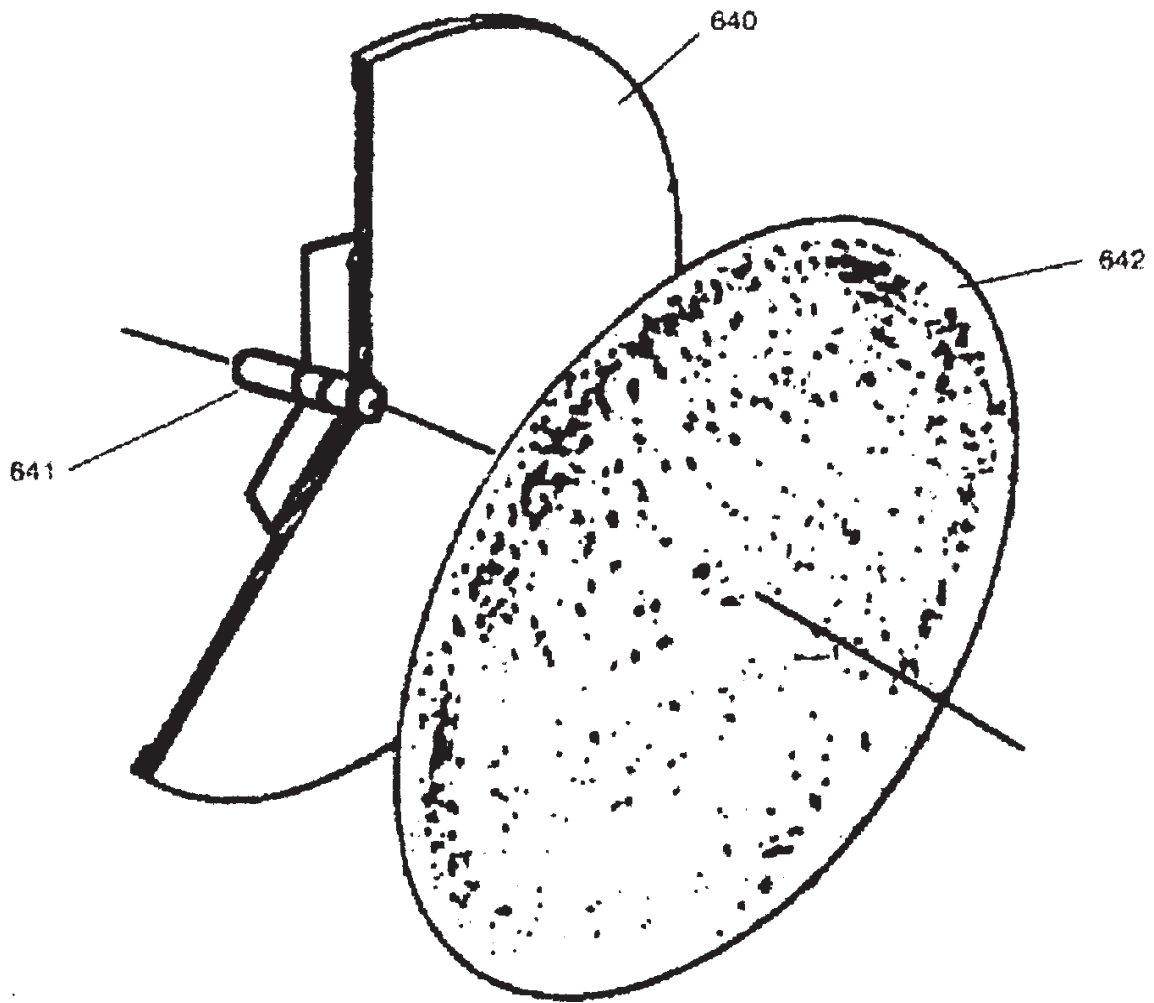

PARTS LIST & ASSY. DIAGRAM - TOOL MOUNTING ASSEMBLIES

Part	Description	Q'ty	Part	Description	Q'ty
647	Handle	1	658	Washer	2
648	Rod	1	659	Nut	1
649	Roll Pin	1	735	Shaper Arbor (Complete)	1
742	Draw Rod (Complete)	1	661	Shaper Arbor	1
650	Drill Arbor	1	662	Spacer	1
651	Drill Chuck & Key	1	663	Spacer	1
652	Spur Drive	1	664	Nut	1
653	R-8 Collet (3/4")	1	665	Shaper Guard	1
734	Saw Arbor (Complete)	1	695	Router Guard	1
656	Saw Arbor	1			

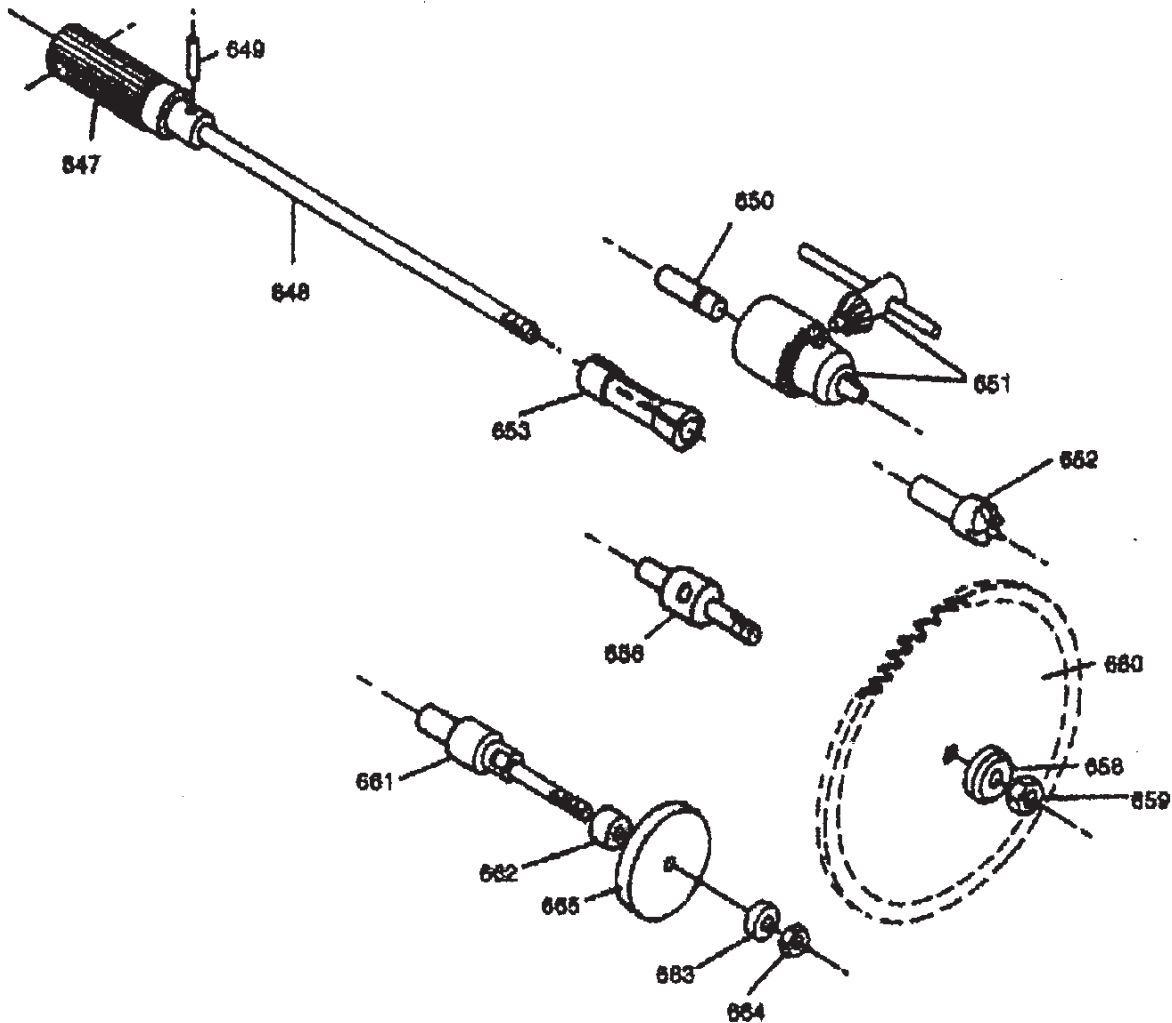

PARTS LIST & ASSY. DIAGRAM - TOOL REST

Part	Description	Q'ty	Part	Description	Q'ty
633	Tool Rest	1	635	Post	1
634	Tool Rest Mount	1	636	Socket Setscrew	2

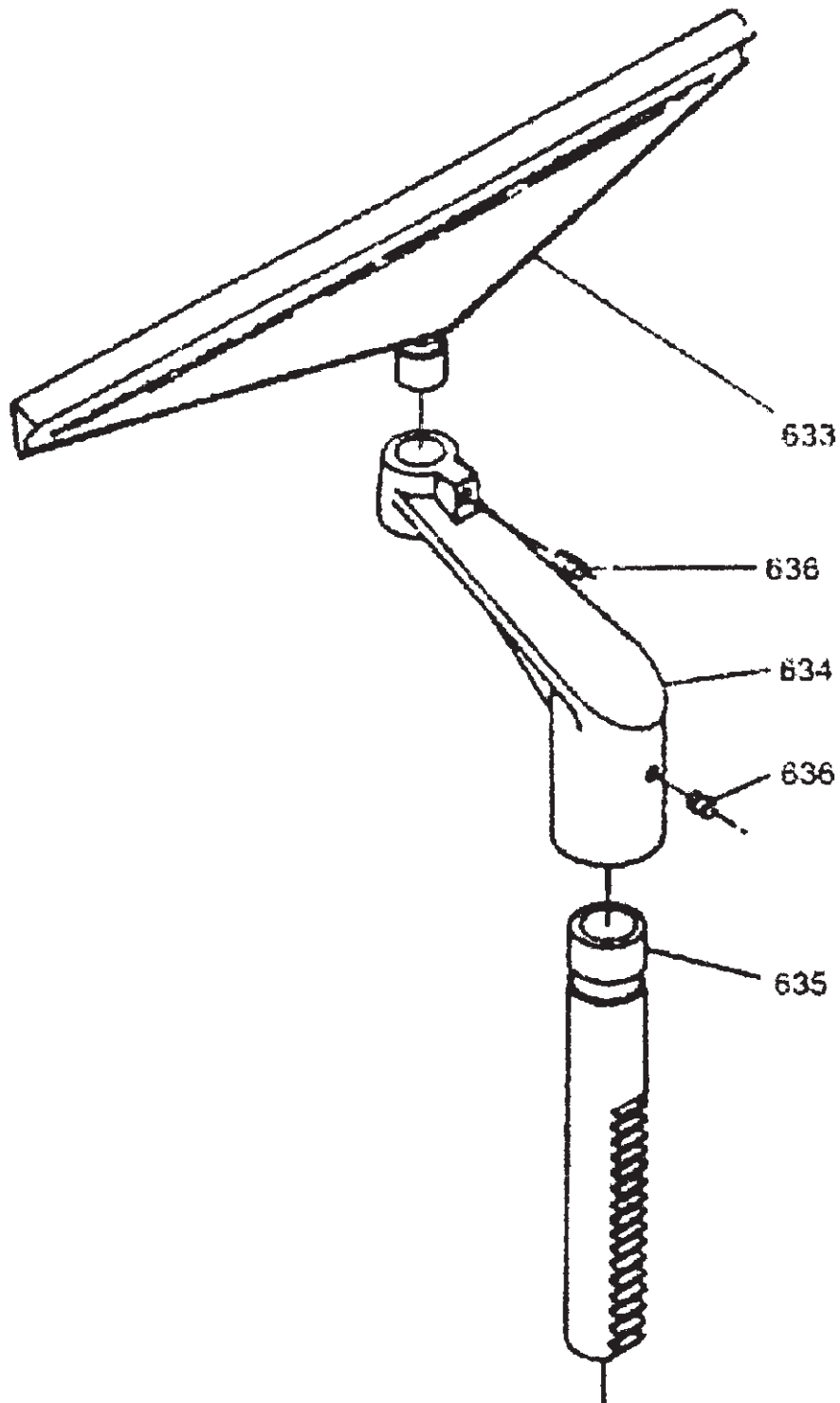

PARTS LIST & ASSY. DIAGRAM - MITER GAUGE ASSY.

Part	Description	Q'ty	Part	Description	Q'ty
612	Miter Gauge Block Assy.	1	672	Disk	2
613	Guide Assy.	1	674	Stud	2
614	Stop Block Assy.	1	675	Frame	1
615	Pointer Plate	1	676	Screw	1
616	Handle	1	677	Spring	1
617	Washer	1	679	Handle	2
618	Roundhead Screw	2	680	Half-Nut	2
619	Flat Washer	2	681	Handle	1
620	Flat Sockethead Capscrew	2	684	Stud	1
694	Setscrew	1			

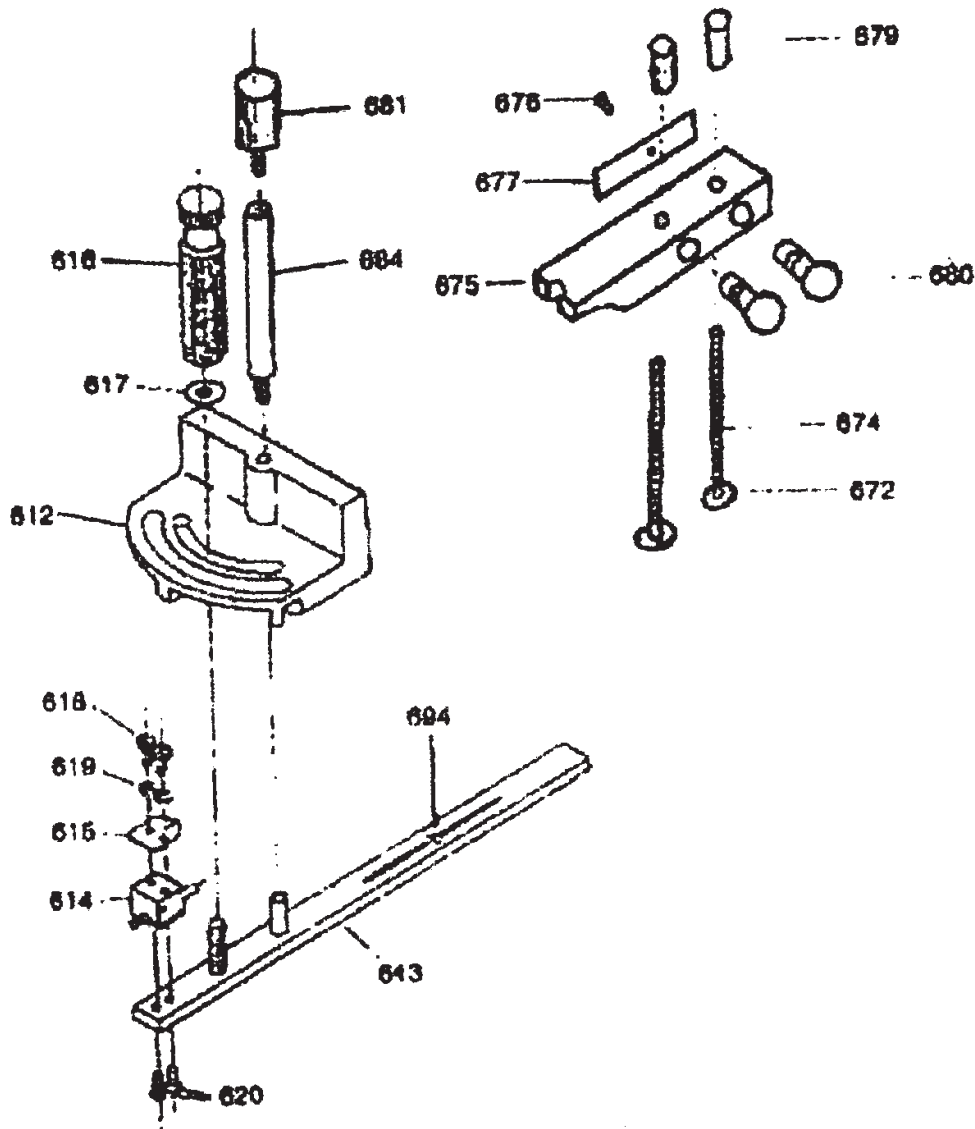

PARTS LIST - ELECTRICAL SYSTEM

Part	Description	Q'ty	Part	Description	Q'ty
701	-----	-----	715	Roundhead Screw	2
702	SCR Module (Head) (Includes SS707 & SS 708)	1	716	Terminal Block	1
703	Flat Sockethead Screw (S11643)	4	717	Coiled Cord Assy.	1
704	Lead	2	718	SCR Module (Carriage) (Includes SS703)	1
705	-----	-----	719	Lead	2
706	Knob	1	720	-----	-----
707	Potentiometer Assy.	1	721	DPDT Reverse Switch	1
708	Knob	1	722	Knob	1
709	Switch, Key, & Nut	1	723	Carriage Motor	1
710	Lead (4)	1	724	Nut	1
711	Indicator Light Assy.	1	741	Module Bracket (not shown)	1
712	Power Cord Assy.	1	777	Drive Motor	1
713	Cord Clamp	3	770	Super Controller Module	1
714	Lockwasher	2			

ASSEMBLY DIAGRAM - ELECTRICAL SYSTEM

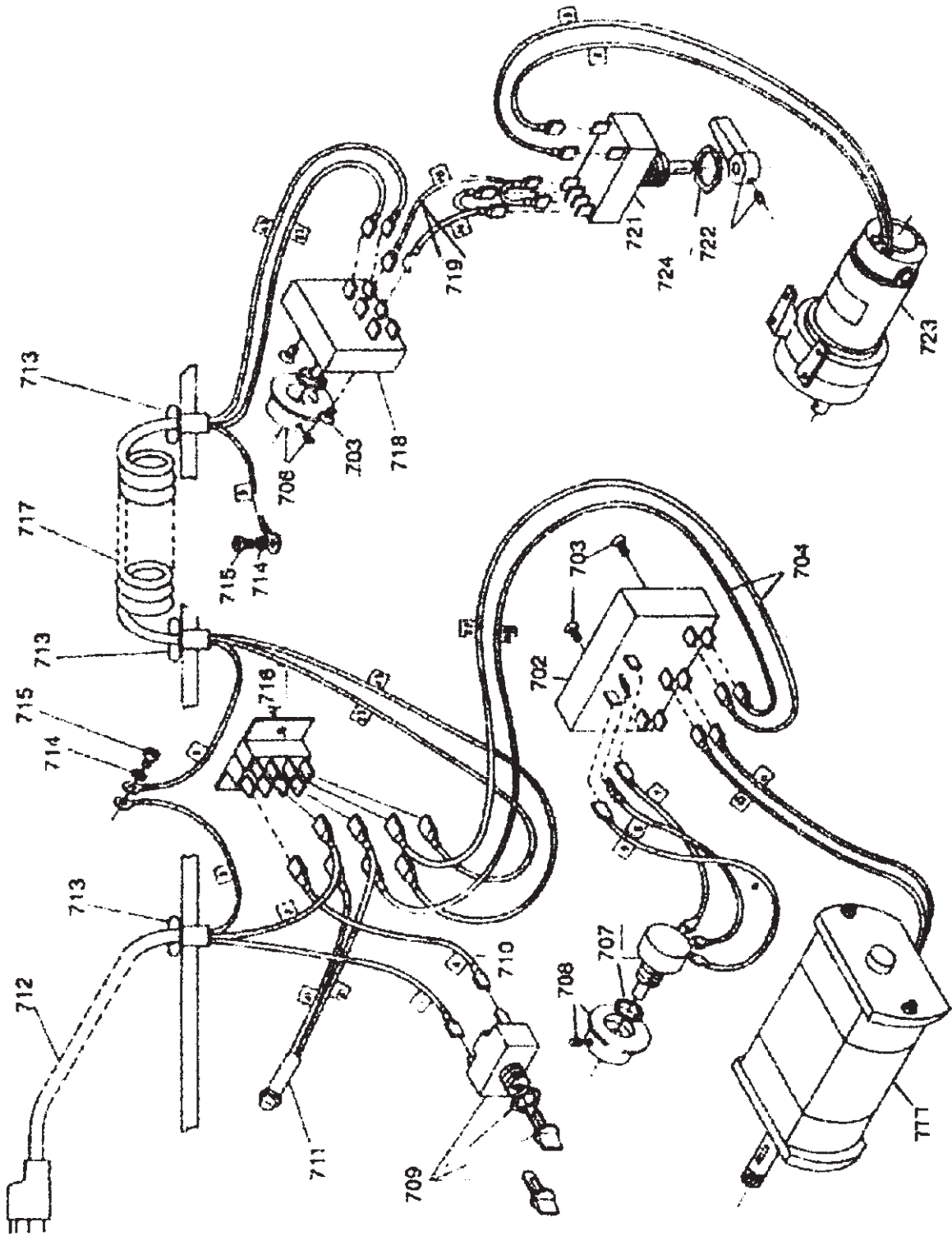

LIMITED 1 YEAR / 90 DAY WARRANTY

Harbor Freight Tools Co. makes every effort to assure that its products meet high quality and durability standards, and warrants to the original purchaser that for a period of ninety days from date of purchase that the engine/motor, the belts (if so equipped), and the blades (if so equipped) are free of defects in materials and workmanship. Harbor Freight Tools also warrants to the original purchaser, for a period of one year from date of purchase, that all other parts and components of the product are free from defects in materials and workmanship. This warranty does not apply to damage due directly or indirectly, to misuse, abuse, negligence or accidents, repairs or alterations outside our facilities, normal wear and tear, or to lack of maintenance. We shall in no event be liable for death, injuries to persons or property, or for incidental, contingent, special or consequential damages arising from the use of our product. Some states do not allow the exclusion or limitation of incidental or consequential damages, so the above limitation of exclusion may not apply to you. THIS WARRANTY IS EXPRESSLY IN LIEU OF ALL OTHER WARRANTIES, EXPRESS OR IMPLIED, INCLUDING THE WARRANTIES OF MERCHANTABILITY AND FITNESS.

To take advantage of this warranty, the product or part must be returned to us with transportation charges prepaid. Proof of purchase date and an explanation of the complaint must accompany the merchandise. If our inspection verifies the defect, we will either repair or replace the product at our election or we may elect to refund the purchase price if we cannot readily and quickly provide you with a replacement. We will return repaired products at our expense, but if we determine there is no defect, or that the defect resulted from causes not within the scope of our warranty, then you must bear the cost of returning the product.

This warranty gives you specific legal rights and you may also have other rights which vary from state to state.

3491 Mission Oaks Blvd. • PO Box 6009 • Camarillo, CA 93011 • (800) 444-3353

Note: Some parts are listed and shown for illustration purposes only, and are not available individually as replacement parts.

Record Product's Serial Number Here: _____

Note: If product has no serial number, record month and year of purchase instead.

PLEASE READ THE FOLLOWING CAREFULLY

THE MANUFACTURER AND/OR DISTRIBUTOR HAS PROVIDED THE PARTS LIST AND ASSEMBLY DIAGRAM IN THIS MANUAL AS A REFERENCE TOOL ONLY. NEITHER THE MANUFACTURER OR DISTRIBUTOR MAKES ANY REPRESENTATION OR WARRANTY OF ANY KIND TO THE BUYER THAT HE OR SHE IS QUALIFIED TO MAKE ANY REPAIRS TO THE PRODUCT, OR THAT HE OR SHE IS QUALIFIED TO REPLACE ANY PARTS OF THE PRODUCT. IN FACT, THE MANUFACTURER AND/OR DISTRIBUTOR EXPRESSLY STATES THAT ALL REPAIRS AND PARTS REPLACEMENTS SHOULD BE UNDERTAKEN BY CERTIFIED AND LICENSED TECHNICIANS, AND NOT BY THE BUYER. THE BUYER ASSUMES ALL RISK AND LIABILITY ARISING OUT OF HIS OR HER REPAIRS TO THE ORIGINAL PRODUCT OR REPLACEMENT PARTS THERETO, OR ARISING OUT OF HIS OR HER INSTALLATION OF REPLACEMENT PARTS THERETO.

Free Manuals Download Website

<http://myh66.com>

<http://usermanuals.us>

<http://www.somanuals.com>

<http://www.4manuals.cc>

<http://www.manual-lib.com>

<http://www.404manual.com>

<http://www.luxmanual.com>

<http://aubethermostatmanual.com>

Golf course search by state

<http://golfingnear.com>

Email search by domain

<http://emailbydomain.com>

Auto manuals search

<http://auto.somanuals.com>

TV manuals search

<http://tv.somanuals.com>