

CENTRAL MACHINERY®

GAS ENGINE - 6.5 HP

Model 94187

ASSEMBLY AND OPERATION INSTRUCTIONS

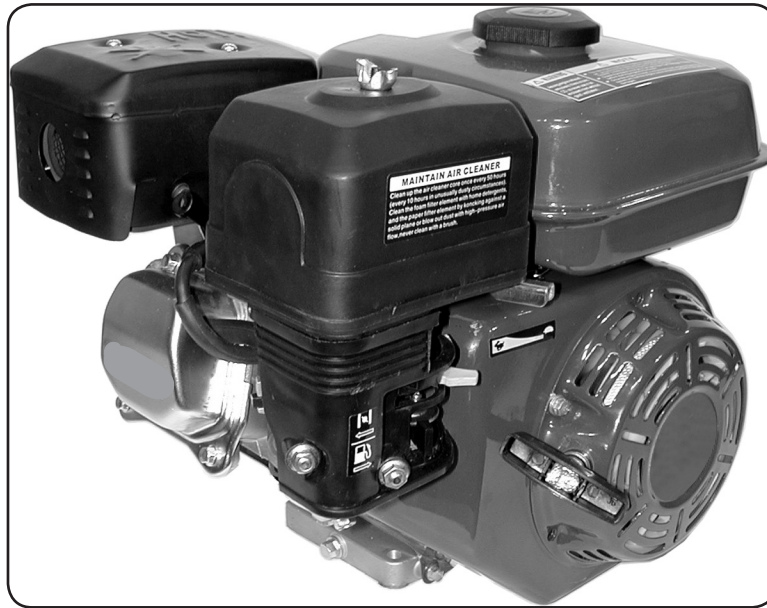

Due to continuing improvements, actual product may differ slightly from the product described herein.



3491 Mission Oaks Blvd., Camarillo, CA 93011

Visit our website at: <http://www.harborfreight.com>

TO PREVENT SERIOUS INJURY, READ AND UNDERSTAND ALL WARNINGS AND INSTRUCTIONS BEFORE USE.

Copyright© 2006, 2007 by Harbor Freight Tools®. All rights reserved. No portion of this manual or any artwork contained herein may be reproduced in any shape or form without the express written consent of Harbor Freight Tools.

For technical questions or replacement parts, please call 1-800-444-3353.

Manual revised 02/07.

Contents

SPECIFICATIONS	3
Save This Manual.....	3
SAFETY WARNINGS AND PRECAUTIONS	3
UNPACKING	5
MOUNTING	6
OPERATION	6
Controls and Indicators	6
Pre-Operation Checks.....	7
TROUBLESHOOTING	8
General/Basic Troubleshooting	8
Engine Difficult to Start	9
Low Engine Power	10
Engine not Running Smoothly.....	10
Engine Excessively Hot.....	11
Abnormal Engine Noise	12
MAINTENANCE	13
Scheduled Maintenance.....	13
Cleaning Air Filter.....	13
Cleaning and Replacing Spark Plug	13
Changing Oil	14
Cleaning the Deposit Cup	14
Torque Value for Major Engine Bolts	15
Transporting the Engine	15
Storing the Engine	15
PARTS LISTS AND ASSEMBLY DIAGRAMS	16
Crankcase	16
Crankcase Cover.....	17
Cylinder Head and Cover	18
Parts List	18
Crankshaft, Piston, and Connecting Rod	19
Camshaft and Rocker Valve	20
Carburetor	21
Fuel Tank.....	22
Air Cleaner	23
Muffler	24
Recoil Starter	25
Regulator Control	26
Flywheel.....	27
Ignition Coil	28
Wiring Diagram	29
WARRANTY	29
Emission Control System Warranty.....	30

SPECIFICATIONS

Power Output	6.5 HP Gas Engine, EPA and CARB approved
Displacement / Stroke	196 cc; 4-stroke
Ignition Type	Electronic ignition (T.C.I.)
Cooling System	Forced air cooling
Idling Carburetor Adjust	1700 +/- 150 RPM
Valve clearance	Cold engine – Intake: 0.15 +/- 0.02mm; Exhaust: 0.20 +/- 0.02 mm
Distributor Timing	Intake valve opening: BTDC10'; Intake valve closing: ABDC20'
Bore and Stroke	68 x 54 mm
Spark Plug Type	BP6ES, BPR6ES (NGK), or NHSPLD F6RTCUC; 0.7~0.8 mm clearance
Gasoline Type	Unleaded
Gasoline Tank Capacity	0.95 gallon (3.6 liters)
Drive Shaft Type	Horizontal, 3/4" straight, (3/16") keyed shaft with ball bearings. Direction: counterclockwise (facing shaft); Length: 2-1/4"; Central thread: 5/16"-24
Start Type	Recoil
Speed	3600 RPM
Oil Capacity and Type	0.528 quart (0.5 liters); SAE 10W30 (in freezing weather use 5W30)
Engine Mounting	Square pattern, 4 holes; 8.0-1.25 mm threads
Weight	33.8 lbs.
Overall Dimensions	12.3 (L) x 15.6 (W) x 13.2 (H) inches
Recommended Applications	To drive: pump, sprayer, tiller, chipper, shredder, log splitter
Features	Low oil shutdown, automatic Longer engine life with bearing supported shaft Meets 2005 EPA Phase II Cal. Emission Regs. Fuel shutoff valve

The Emission Control System for this generator's engine is warranted for standards set by the U.S. Environmental Protection Agency and by the California Air Resources Board (also known as CARB). For warranty information, refer to the back two pages of this manual.

Save This Manual

You will need the manual for the safety warnings and precautions, assembly instructions, operating and maintenance procedures, parts list and diagram. Keep your invoice with this manual. Write the invoice number on the inside of the front cover. Keep the manual and invoice in a safe and dry place for future reference.



SAFETY WARNINGS AND PRECAUTIONS

WARNING: When using this Gas Engine, basic safety precautions should always be followed to reduce the risk of personal injury and damage to equipment.

Read all instructions before using this tool!

1. **Keep work area clean.** Cluttered areas invite injuries.
2. **Observe work area conditions.** Do not use machines or power tools in damp or wet locations. Don't expose to rain. Keep work area well lighted. Do not use electrically powered tools in the presence of flammable gases or liquids.

3. **Keep children away.** Children must never be allowed in the work area. Do not let them handle machines, tools, or extension cords.
4. **Store idle equipment.** When not in use, tools must be stored in a dry location to inhibit rust. Always lock up tools and keep out of reach of children.
5. **Dress properly.** Do not wear loose clothing or jewelry as they can be caught in moving parts. Wear restrictive hair covering to contain long hair.
6. **Use the right tool for the job.** Do not attempt to force a small tool or attachment to do the work of a larger industrial tool. There are certain applications for which this tool was designed. It will do the job better and more safely at the rate for which it was intended. Do not modify this tool and do not use this tool for a purpose for which it was not intended.
7. **Use eye and ear protection.** Always wear ANSI approved impact safety goggles and ear plugs.
8. **Do not overreach.** Keep proper footing and balance at all times. Do not reach over or across running machines.
9. **Maintain tools with care.** Keep tools sharp and clean for better and safer performance. Follow instructions for lubricating and changing accessories.
10. **Remove adjusting keys and wrenches.** Check that keys and adjusting wrenches are removed from the tool or machine work surface before starting.
11. **Avoid unintentional starting.** Be sure the power switch and gas valve are in the Off position when not in use.
12. **Stay alert.** Watch what you are doing, use common sense. Do not operate any tool when you are tired.
13. **Check for damaged parts.** Before using this Gas Engine, any part that appears damaged should be carefully checked to determine that it will operate properly and perform its intended function. Check for alignment and binding of moving parts; any broken parts or mounting fixtures; and any other condition that may affect proper operation. Any part that is damaged should be properly repaired or replaced by a qualified technician. Do not use the Gas Engine if the switch does not turn On and Off properly.
14. **Do not operate this Gas Engine if under the influence of alcohol or drugs.** Read warning labels if taking prescription medicine to determine if your judgment or reflexes are impaired while taking drugs. If there is any doubt, do not operate the tool.
15. **Maintenance.** For your safety, service and maintenance should be performed regularly by a qualified technician.
16. **People with pacemakers should consult their physician(s) before use.** Electromagnetic fields in close proximity to heart pacemaker could cause pacemaker interference or pacemaker failure.
Caution is necessary when near coil, spark plug cables, or distributor of running engine. Engine should be off during distributor adjustment.

17.  **Fire Hazard!** Do not fill gas tank when the engine is running. Do not operate if gasoline has been spilled. Clean spilled gasoline before starting the engine. Do not operate near a pilot light or open flame.
18.  **Operate the engine in well ventilated areas only.** Carbon Monoxide is produced during operation and is deadly in a closed environment. Early signs of Carbon Monoxide poisoning resemble the flu, with headaches, dizziness, or nausea. If you have these signs, the engine may not be working properly, or is being used indoors. Get fresh air immediately.
19. **Avoid burns from the engine.** Certain parts of the engine become very hot during use. Do not touch the engine until it cools down after use.
20. **Install this product on a proper surface.** Locate on a flat, level, and solid surface that is capable of supporting the weight of the engine and the machinery that it is turning.
21. **Do not operate the engine with safety guards removed.** While the engine is running, do not attempt to reach around the safety guards for maintenance or any other reason.
22. **If the engine is installed indoors, exhaust fumes must be piped out of the building using leak-free, heat-resistant piping.** Pipes and silencer should not use any flammable materials, nor should they be installed near the same. Engine exhaust fumes should be within legal limits.
23. **Engine fuel and fumes are flammable, and potentially explosive. Do not smoke, or allow sparks, flames or other sources of ignition around the engine, fuel tanks, or batteries.** Use proper fuel storage and handling procedures. Always have multiple ABC class fire extinguishers nearby.
24. **Never store fuel or other flammable materials near the engine.**
25. **Keep hands, arms, long hair, loose clothing, and jewelry away from pulleys, belts, and other moving parts.** Be aware that when engine parts are moving fast they cannot be seen clearly.
26. **The engine can produce high noise levels.** Prolonged exposure to noise levels above 85 dBA is hazardous to hearing. Always wear ear protection when operating or working around the Gas Engine when it is running.

Warning: The warnings, cautions, and instructions discussed in this instruction manual cannot cover all possible conditions and situations that may occur. It must be understood by the operator that common sense and caution are factors which cannot be built into this product, but must be supplied by the operator.

UNPACKING

When unpacking, check to make sure the following parts are included. If any parts are missing or broken, please call Harbor Freight Tools at the number on the cover of this manual as soon as possible.

MOUNTING

1. Mount the Engine using its four mounting holes at the base (hardware not supplied). Select a flat, smooth location able to withstand the weight, vibration, and the load device connected to the Engine. If installed indoors, proper exhaust ventilation tubing must be installed. If installed outdoors, a weatherproof housing is recommended.
2. Install the Engine load.
The Engine load must be perfectly aligned with the Engine drive shaft to prevent undue wear on the shaft and bearings. A qualified technician should do this.

OPERATION

Controls and Indicators

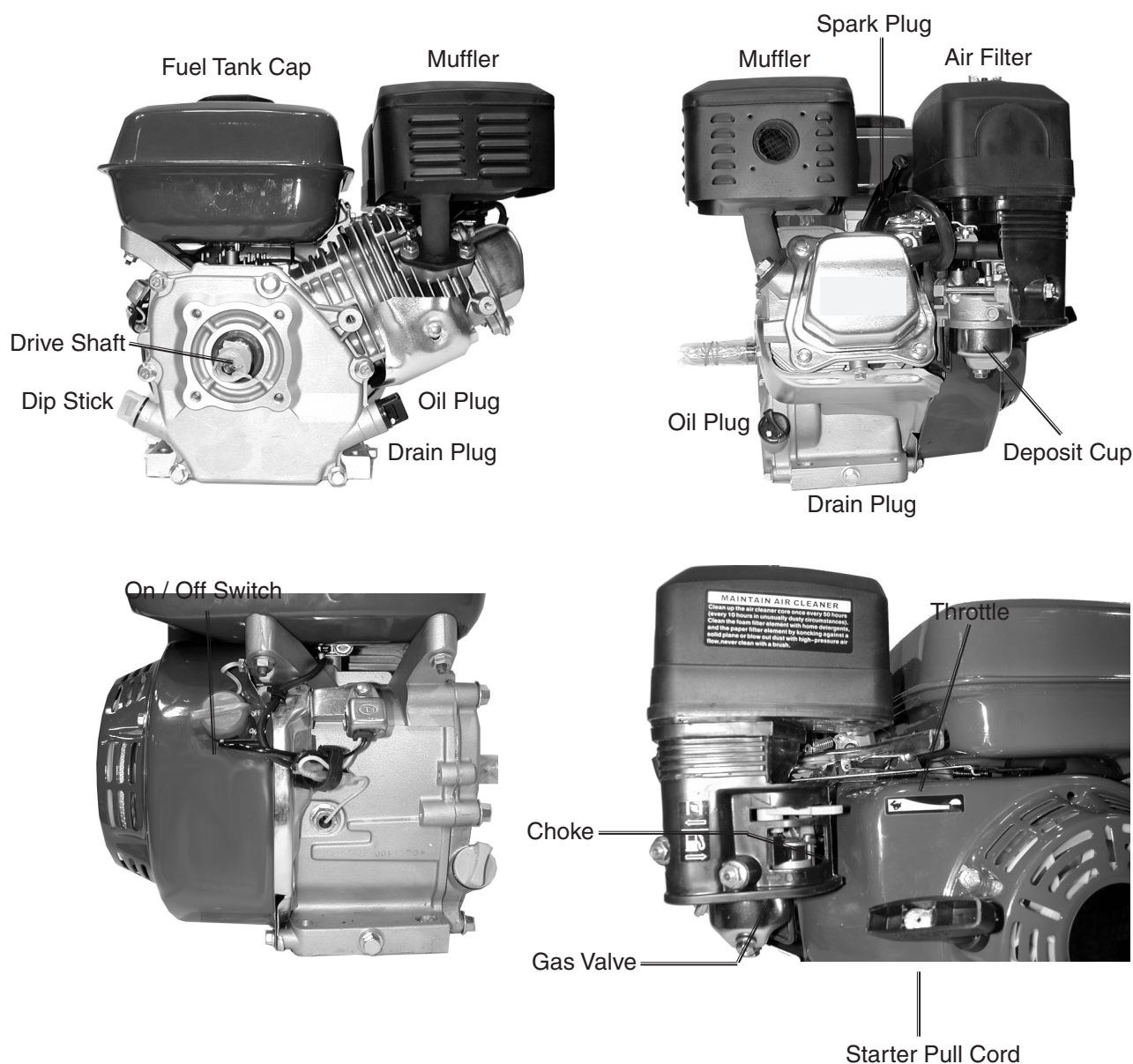

Pre-Operation Checks

Caution: Failure to add oil to the Engine before use will damage the Engine and void the factory warranty. Engine oil is the key factor in engine performance. Do not use Engine oil with additives; Do not use two-stroke gasoline-oil. Using these will shorten Engine life. See Specifications on page 2 for recommended oil type.

1. Check that all installation mounting nuts and bolts are tight.
2. Check oil level (See illustration below, left.) If needed, add oil as specified on page 2. Unscrew the oil Dip Stick and wipe clean. Insert the Dip Stick back into the hole without screwing it in. Remove it again and check the oil level. Full is indicated by oil on the Upper Level mark. Use a siphon to avoid spilling the oil. Carefully screw the plastic Dip Stick back into the metal Engine crankcase to avoid stripping the plastic threads on the Dip Stick.

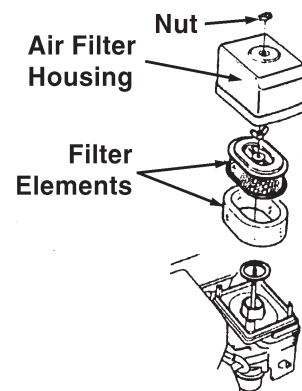
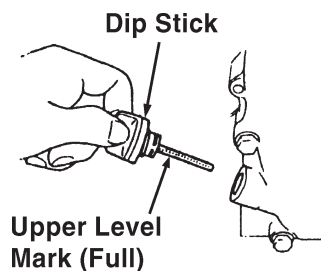

3. Check Air Filter. (See illustration above, right.) Unscrew Air Filter Housing Nut and remove the Air Filter Housing and Filter Elements. If dirty or dusty, clean (refer to the Maintenance Section).

Caution: Never run the Engine without the Air Filter assembly. Damage will occur to Engine.

4. Remove the debris filter, clean and replace it before filling. Fill the Gas Tank (outdoors) with up to 0.95 of a gallon of unleaded gasoline containing at least 86 octane. Do not top-off tank. Replace Gas Cap. Clean up any spilled gas with a dry cloth.

Fire Hazard! Do not fill Gas Tank when the Engine is running, or near a pilot light or open flame; Do not smoke. Do not operate if gasoline has been spilled. Clean spilled gasoline before starting the engine.

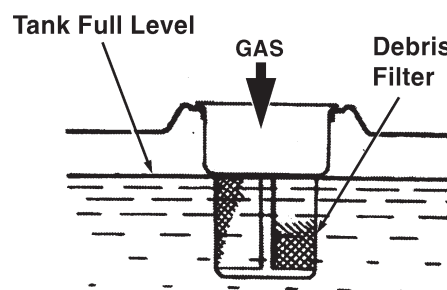
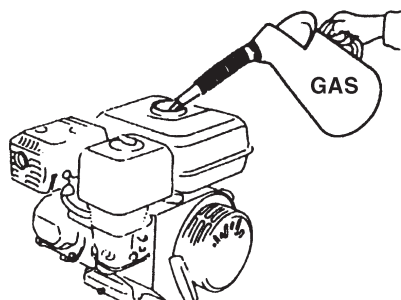

Starting the Engine

During this procedure, it may be helpful to refer to the photos of the Engine Controls on page 5.

1. Push the Gas Valve to the open (right) position. 

2. Close the Choke by pulling it to the left. 

Note: If the Engine is already hot, it is not necessary to close the Choke.

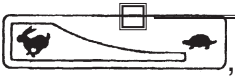
3. Push the Throttle Lever to the slow (right) position  Throttle Setting, then move it back slightly.

4. Turn the On/Off Switch to the On position.

5. Gently pull the Starter Pull Cord until it engages. Then pull it hard and all the way out. Slowly guide the Pull Cord back into the starter.

The Engine should start. Try again if it does not start. Refer to the Troubleshooting section if problems persist. Let the engine run for five minutes to warm up.

6. Push in the Choke Lever to the right/ 

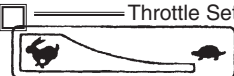
7. Push the Throttle Lever to the fast position (left).  Throttle Setting

Stopping the Engine

1. Push the Throttle Lever to the slow (right) position.
2. Turn the On/Off Switch to the Off position.
3. Push the Gas Valve to the closed (left) position.

TROUBLESHOOTING

General/Basic Troubleshooting

Symptom	Probable Cause	Possible Remedy
Engine will not start.	<ol style="list-style-type: none"> 1. On/Off Switch in Off position. 2. Gas Valve in closed position. 3. Choke set to open position. 4. Gas Tank empty. 5. Spark plug dirty. 6. Technical problem. 	<ol style="list-style-type: none"> 1. Turn to On position. 2. Push to open position. 3. Set to closed position. 4. Fill Gas Tank. 5. Remove spark plug and clean. 6. Service by qualified mechanic.
Engine runs rough, pinging noises.	<ol style="list-style-type: none"> 1. Gasoline wrong type. 2. Gasoline has water. 	<ol style="list-style-type: none"> 1. Replace with 89 octane gas. 2. Empty tank and replace gas.
Engine stops by itself, but has gas.	<ol style="list-style-type: none"> 1. Low oil level auto shut off. 2. Technical problem. 	<ol style="list-style-type: none"> 1. Check oil level; Add if needed. 2. Service by qualified mechanic.
Engine does not reach full speed.	<ol style="list-style-type: none"> 1. Choke closed. 2. Air filters clogged. 3. Technical problem. 	<ol style="list-style-type: none"> 1. Open Choke. 2. Clean air filter elements. 3. Service by qualified mechanic.

Engine Difficult to Start

Symptom	Probable Cause	Possible Remedy
Engine difficult to start – Cylinder compression OK – Spark OK	Fuel supply blocked: 1. Air vent in Gas Cap clogged. 2. Gas Valve plugged up 3. Main jet clog or misadjusted 4. Needle valve improperly closed or start hole is clogged 5. Floater in fuel tank is damaged or sticking	1. Clean Gas Cap air vent 2. Unclog Gas Valve 3. Clean and/or readjust 4. Take apart needle valve and repair, clean, and blow out 5. Repair floater
Engine difficult to start – Cylinder compression OK – Spark OK – Gas supply OK	Fuel system problem: 1. Gas dirty, has water, or is old 2. Engine cylinder flooded 3. Gas wrong type	1. Drain gas and replace 2. Drain extra gas, dry spark plug electrodes 3. Drain gas and replace
Engine difficult to start – Cylinder Compression OK – Gas supply OK – Ignition coil spark OK	1. Spark plug has carbon buildup or dirt on and around electrodes 2. Electrodes are burned 3. Improper spark gap	1. Remove spark plug and clean 2. Replace spark plug 3. Adjust spark plug electrodes
Engine difficult to start – Gas supply OK – Ignition system OK	1. Piston ring worn 2. Piston ring is sticking 3. Piston ring broken 4. Spark plug loose or without a gasket 5. Air leakage between cylinder block and cylinder 6. Air leakage in valve	1. Replace piston rings 2. Clean out carbon fouling 3. Replace piston ring 4. Tighten with a gasket 5. Check cylinder gasket and bolts 6. Check valve clearance and thickness, repair if required

Low Engine Power

Symptom	Probable Cause	Possible Remedy
When pressing Throttle for higher speed, engine responds slowly; speed is decreased; or engine stops.	Incorrect Ignition timing.	Re-adjust ignition advance angle.
	Fuel supply problem: <ol style="list-style-type: none"> 1. Fuel line is clogged or has air 2. Main jet not adjusted properly 3. Carburetor needle valve hole and main jet clogged 4. Gas valve clogged 5. Carbon buildup in combustion chamber. 6. Air filter is clogged. 7. Intake pipe leaking. 	<ol style="list-style-type: none"> 1. Clean line. Bleed line of air. 2. Readjust jet. 3. Clean needle valve hole and main jet 4. Clean or replace gas valve. 5. Clean combustion chamber. 6. Clean filter elements. 7. Repair or replace.
	Low compression: <ol style="list-style-type: none"> 1. Piston, piston ring, or cylinder worn. 2. Air leakage from surface where cylinder block contacts cylinder head. 3. Valve clearance incorrect. 4. Valve tightness poor. 	<ol style="list-style-type: none"> 1. Replace damaged part. 2. Replace cylinder gaskets. 3. Adjust valve. 4. Repair or replace valve.

Engine not Running Smoothly

Symptom	Probable Cause	Possible Remedy
Engine pinging.	<ol style="list-style-type: none"> 1. Piston, ring, or cylinder worn. 2. Piston pin and pin hole are worn excessively. 3. Tie rod small head is worn. 4. Main crankshaft roller bearing worn. 	<ol style="list-style-type: none"> 1. Replace worn part. 2. Replace piston and/or pin. 3. Replace tie rod. 4. Replace roller bearing.
Abnormal combustion.	<ol style="list-style-type: none"> 1. Engine too hot. 2. Carbon fouling in combustion chamber. 3. Wrong gasoline type. 	<ol style="list-style-type: none"> 1. Troubleshoot overheating (see page 11). 2. Clean chamber. 3. Drain gas from system and replace with correct type.
Spark plug not firing correctly	<ol style="list-style-type: none"> 1. Water in carburetor float chamber. 2. Spark plug electrode gap wrong. 3. Incorrect ignition timing. 4. Ignition coil malfunction. 	<ol style="list-style-type: none"> 1. Clean Carburetor. 2. Adjust spark plug gap. 3. Re-adjust. 4. Repair or replace coil.

Symptom	Probable Cause	Possible Remedy
Engine stops suddenly.	<ol style="list-style-type: none"> 1. Gas tank empty. 2. Carburetor clogged 3. Floater is leaking. 4. Needle valve sticks. 5. Spark plug dirty or damaged. 6. Spark plug connector wire damaged or disconnected. 7. Low oil auto-shutdown. 8. Ignition coil damaged. 9. Cylinder or valve damaged. 	<ol style="list-style-type: none"> 1. Fill gas tank. 2. Clean carburetor and check fuel line. 3. Repair or replace. 4. Disassemble floater chamber and clean. 5. Replace spark plug. 6. Check and repair spark plug wire. 7. Fill with oil. 8. Repair or replace. 9. Disassemble, check, and repair.

Engine Excessively Hot

Symptom	Probable Cause	Possible Remedy
Engine runs excessively hot.	<ol style="list-style-type: none"> 1. Ignition timing off. 2. Engine oil low. 3. Exhaust pipe or muffler clogged. 4. Flow guard is leaking. 5. Cooling fan loose, damaged, or clogged. 6. Cylinder, piston, or piston ring is worn resulting in air flow between cylinder and crankcase. 7. Engine speed maximum set too high. 8. Crankshaft main bearing burnt. 	<ol style="list-style-type: none"> 1. Adjust ignition advance angle. 2. Fill with oil. 3. Clean out exhaust pipe and muffler. 4. Repair leakage. 5. Clean, repair, or replace fan. 6. Replace damaged parts. 7. Re-adjust engine speed governor. 8. Replace main bearing.

Abnormal Engine Noise

Symptom	Probable Cause	Possible Remedy
Noise of piston banging, or other metal-on-metal	<ol style="list-style-type: none"> 1. Piston, piston ring, or cylinder worn. 2. Tie rod, piston pin and hole worn. 3. Crankshaft main bearing worn. 4. Piston ring broken. 5. Carbon deposits in combustion chamber. 6. Spark plug gap too small. 7. Using wrong gasoline. 8. Engine running too hot. 9. Incorrect valve clearance. 10. Flywheel not tightly connected to crankshaft. 	<ol style="list-style-type: none"> 1. Replace worn parts. 2. Replace worn parts. 3. Replace main bearing. 4. Replace piston ring. 5. Clean combustion chamber. 6. Adjust electrode clearance. 7. Empty gas tank and refill with proper gasoline. 8. See Troubleshooting Excessively Hot Engine. 9. Readjust valve clearance. 10. Retighten flywheel.

MAINTENANCE

Before performing maintenance procedures, it may be helpful to locate the items to be serviced in the photos on page 5. Many Engine maintenance, adjustments, and repairs must be completed by a qualified, small engine mechanic.

Scheduled Maintenance

Item	Frequency	Each Use	First month or 20 hours	Each 50 hours	Every 6 months or 100 hrs.	Each year or 300 hrs.
Engine oil		Check	Replace		Replace	
Air Filter		Check		Clean	Clean	Replace
Spark Plug					Clean & Adjust	Replace
Spark Eliminator					Clean	
Idling						Check & Adjust*
Valve Clearance						Check & Adjust**
Fuel Tank & Filter						Clean
Fuel Line						Check
Deposit Cup					Clean	

* Proper Idle: 1700 ± 150 RPM

** Valve Clearance
(cold engine)

Intake: 0.15 ± 0.02mm
Exhaust: 0.20 ± 0.02mm

Cleaning Air Filter

Using compressed air, blow the dust from both elements and the Filter Base on the Engine. If the Filter Elements cannot be cleaned, wash the foam element with mild soap and water, and dry. Purchase a new paper Filter Element if necessary. Reinstall Filter Elements, Air Filter Housing, and Nut.

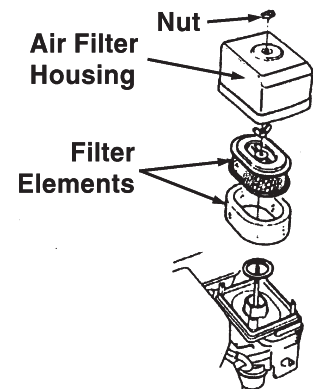

Cleaning and Replacing Spark Plug

1. Remove the Spark Plug with a socket wrench (not supplied). Wait for the Engine to cool to avoid burning hands.

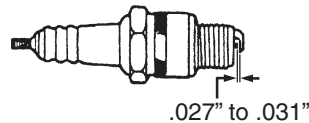
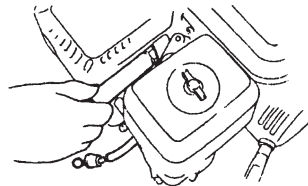

2. Clean Spark Plug with a steel brush. If the insulator is damaged, replace Spark Plug.

Caution: Using other than the recommended Spark Plug replacement type can damage the Engine (see Specifications on page 2).

3. Measure the Spark Plug electrode gap with a feeler gauge (not supplied). It should be between 0.7 to 0.8 mm. If adjustment is necessary, bend the side electrode carefully, then re-measure. If Spark Plug Gasket is damaged, replace it.

4. Replace Spark Plug by hand for the first few turns, then tighten with the socket wrench completely. Securely tighten. A Spark Plug with a new Gasket requires 1/2 more turns to tighten than the used Gasket which requires 1/8 to 1/4 turns to tighten.

Changing Oil

1. Run the Engine for five minutes to warm up the oil, then shut off the Engine.
2. Place a drain pan under the Drain Plug.
3. Remove the Dip Stick and unscrew the Drain Plug.

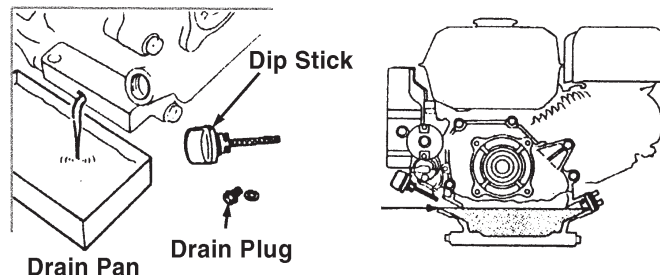

4. Allow all the oil to drain out into the pan. Pour the used oil into a container with a lid. Deliver used oil to a recycling center. Do not dump oil into the earth or storm drain. Dispose of oil properly.
5. Replace Drain Plug and securely tighten.
6. Add 1/2 quart of 10W30 motor oil through a funnel (not included) into the Dip Stick fill hole. Fill until the oil reaches the Upper Level line of the fill hole.
7. Replace the Dip Stick, being careful not to strip its plastic threads.

Cleaning the Deposit Cup

1. Push the Gas Valve to the closed (left) position.
2. Using a wrench (not supplied), loosen and remove the Bolt under the Deposit Cup. Place a pan below the Deposit Cup to catch any remaining gasoline.
3. Remove the Deposit Cup and O-ring, and wash them in cleaning solvent.
4. Reinstall the Deposit Cup.
5. Push the Gas Valve to the open (right) position and check for gas leaks from the Deposit Cup. If leaks are found, reinstall the Deposit Cup and tighten hardware.

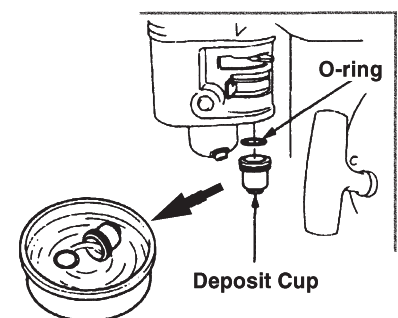

Torque Value for Major Engine Bolts

Item	Torque Value (ft-lb)
Cylinder Head Bolts	18
Flywheel Bolt	52~59
Crankcase Cover Bolts	18
Connecting Rod	9

Transporting the Engine

1. Press the Gas Valve to the left (closed) position.
2. Wait until the engine is cool before lifting and moving.
3. Keep the Engine level while carrying with another person.

Storing the Engine

1. Replace the Engine oil with new oil before storing as described on page 13.
2. Remove the Spark Plug as described on page 12. Add a spoon of new Engine oil through the Spark Plug mounting hole, into the cylinder. Rotate the driveshaft to distribute the oil evenly. Replace the Spark Plug. Wipe up any spilled oil.

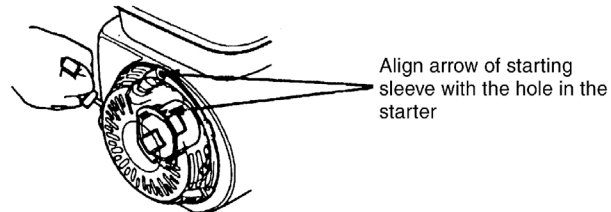
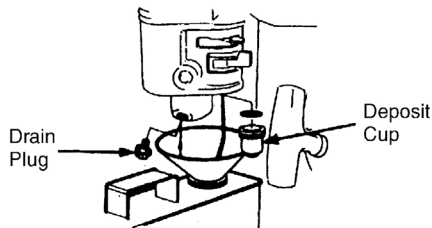

3. With a gas can (and funnel, neither included) underneath the Deposit Cup, unscrew the Drain Plug of the Deposit Cup and drain all the gasoline from the Gas Tank. The Gas Valve must be open. When drained, replace the Drain Plug. See illustration above, left.
4. Pull the Starter Pull Cord slowly, and when it engages keep pulling until the arrow on the starting sleeve aligns with the hole of the starter. See illustration above, right. This step ensures that the inlet and outlet valves are closed, preventing a buildup of moisture and rust within the engine.
5. Cover the Engine with a waterproof cover.

PARTS LISTS AND ASSEMBLY DIAGRAMS

Crankcase Assembly Diagram

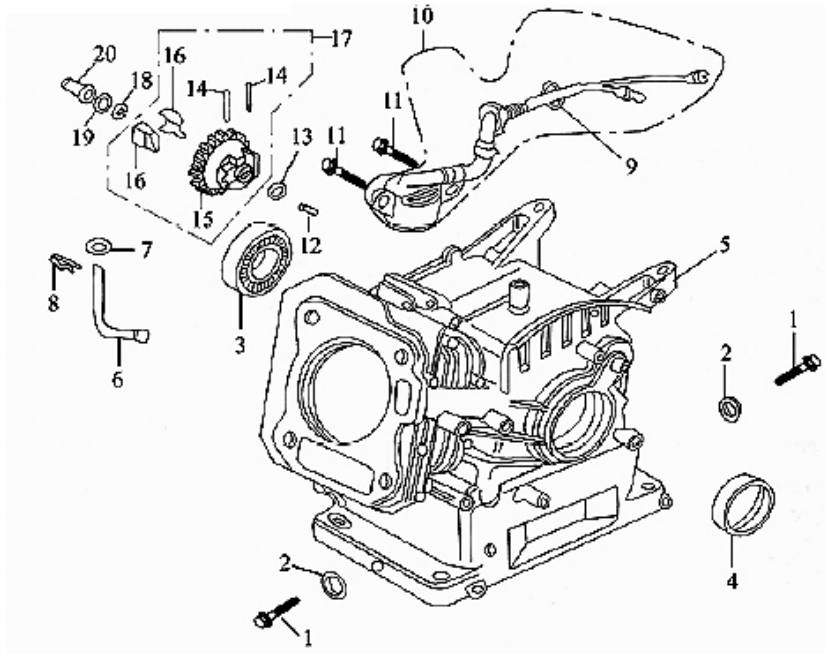

Note: When ordering parts from this list, specify: CRANKCASE ASSEMBLY and the ITEM No.

Parts List

Part	Description	Q'ty
1	Drain Plug	2
2	Washer	2
3	Bearing, 6205	1
4	Seal, Oil, Crankshaft	1
5	Crankcase	1
6	Sway Bar, Regulator	1
7	Washer	2
8	Pin, Split	1
9	Nut, M10	1
10	Sensor, Oil	1

Part	Description	Q'ty
11	Bolt, M6x14	2
12	Regulating Shaft	1
13	Washer, Drive Gear	1
14	Pin	2
15	Drive Gear, Regulator	1
16	Fly Block	2
17	Drive Gear Assy, Regulator	1
18	Snap Ring	1
19	Washer	2
20	Sliding Sleeve	1

Note: Some parts, on this Parts List and the Parts Lists that follow, are listed and shown for illustration purposes only and are not available individually as replacement parts.

Crankcase Cover Assembly Diagram

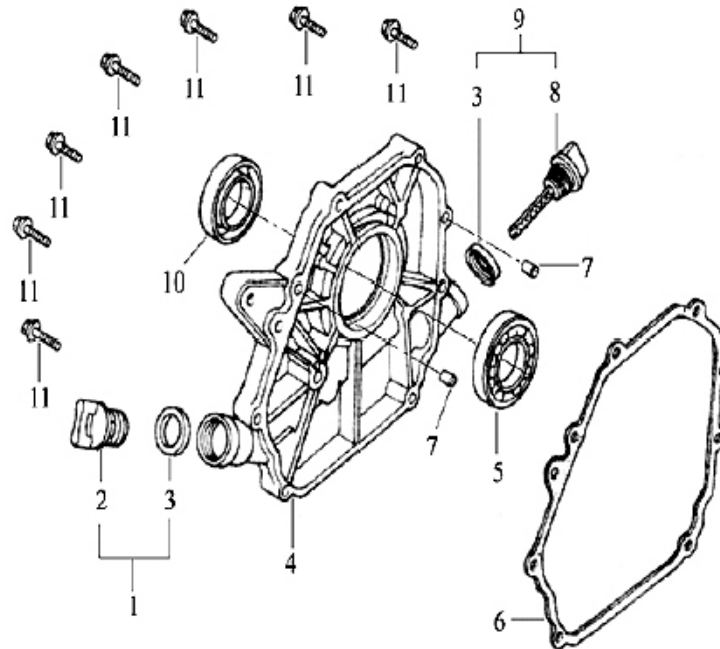

Note: When ordering parts from this list, specify: CRANKCASE COVER ASSEMBLY and the ITEM No.

Parts List

Part	Description	Q'ty
1	Oil Plug with Seal	1
2	Oil Plug	1
3	Seal	2
4	Crankcase Cover	1
5	Bearing, 6250	1
6	Gasket, Crankcase	1

Part	Description	Q'ty
7	Pin, Set	2
8	Dipstick	1
9	Dipstick with seal	1
10	Oil Seal, Crankshaft	1
11	Bolt, M8x32	7

PLEASE READ THE FOLLOWING CAREFULLY

THE MANUFACTURER AND/OR DISTRIBUTOR HAS PROVIDED THE PARTS LIST AND ASSEMBLY DIAGRAM IN THIS MANUAL AS A REFERENCE TOOL ONLY. NEITHER THE MANUFACTURER OR DISTRIBUTOR MAKES ANY REPRESENTATION OR WARRANTY OF ANY KIND TO THE BUYER THAT HE OR SHE IS QUALIFIED TO MAKE ANY REPAIRS TO THE PRODUCT, OR THAT HE OR SHE IS QUALIFIED TO REPLACE ANY PARTS OF THE PRODUCT. IN FACT, THE MANUFACTURER AND/OR DISTRIBUTOR EXPRESSLY STATES THAT ALL REPAIRS AND PARTS REPLACEMENTS SHOULD BE UNDERTAKEN BY CERTIFIED AND LICENSED TECHNICIANS, AND NOT BY THE BUYER. THE BUYER ASSUMES ALL RISK AND LIABILITY ARISING OUT OF HIS OR HER REPAIRS TO THE ORIGINAL PRODUCT OR REPLACEMENT PARTS THERETO, OR ARISING OUT OF HIS OR HER INSTALLATION OF REPLACEMENT PARTS THERETO.

Cylinder Head and Cover Assembly Diagram

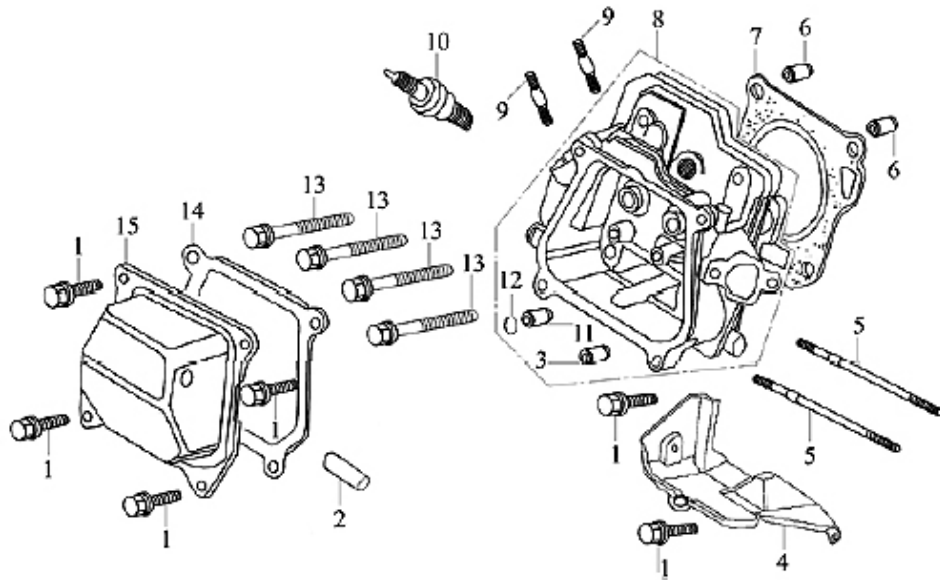

Note: When ordering parts from this list, specify: CYLINDER HEAD AND COVER ASSEMBLY and the ITEM No.

Parts List

Part	Description	Q'ty
1	Bolt, M6x12	6
2	Air duct	1
3	Intake Valve Guide	1
4	Lead Wind Cover	1
5	Stud, M6x109	2
6	Pin, Set 10x16	2
7	Gasket, Cylinder Head	1
8	Cylinder Head Assembly	1

Part	Description	Q'ty
9	Stud, M8x34	2
10	Spark Plug, F6TC	1
11	Exhaust Valve Guide	1
12	Circle Clip	1
13	Bolt	4
14	Gasket, Cylinder Head Cover	1
15	Cylinder Head Cover Assembly	1

Crankshaft, Piston, and Connecting Rod Assembly Diagram

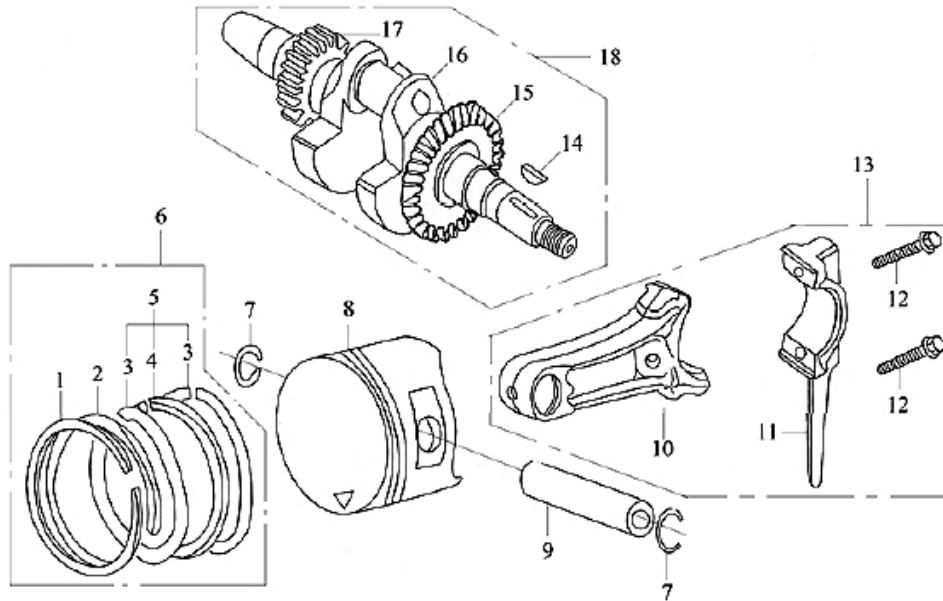

Note: When ordering parts from this list, specify: CRANKSHAFT, PISTON, AND CONNECTING ROD ASSEMBLY and the ITEM No.

Parts List

Part	Description	Q'ty
1	Piston Ring (I)	1
2	Piston Ring (II)	1
3	Side Rail	2
4	Expander	1
5	Scraper Ring Set	1
6	Piston Ring Assembly	1
7	Piston Pin Circle Clip	2
8	Piston	1
9	Piston Pin	1

Part	Description	Q'ty
10	Connecting Rod	1
11	Connecting Rod Cover	1
12	Bolt	2
13	Connecting Rod Assembly	1
14	Woodruff Key	1
15	Drive Gear	1
16	Crankshaft	1
17	Timing Drive Gear	1
18	Crankshaft Assembly	1

Camshaft and Rocker Valve Assembly Diagram

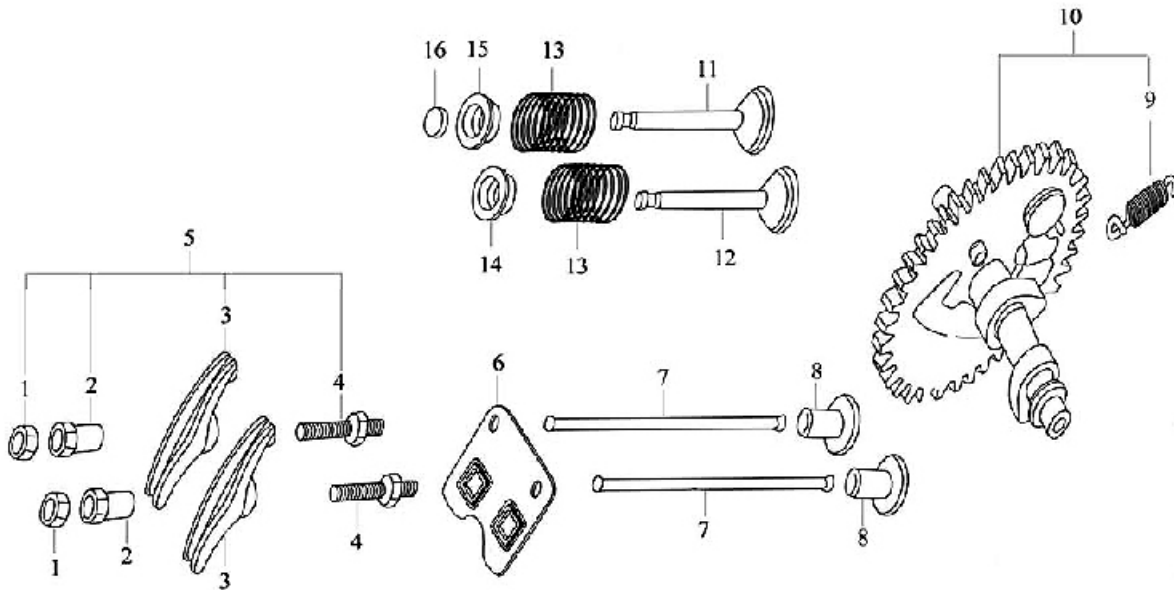

Note: When ordering parts from this list, specify: CAMSHAFT AND ROCKER VALVE ASSEMBLY and the ITEM No.

Parts List

Part	Description	Q'ty
1	Lock Nut	2
2	Sleeve	2
3	Valve, Rocker	2
4	Bolt, Adjusting, Valve Gap	2
5	Valve, Rocker, Assembly	2
6	Pusher Guide	1
7	Pusher	2
8	Tappet	2

Part	Description	Q'ty
9	Spring, Extension	1
10	Camshaft Assembly	1
11	Valve, Exhaust	1
12	Valve, Intake	1
13	Spring, Valve	2
14	Spring Seat, Intake Valve	1
15	Spring Seat, Exhaust Valve	1
16	Cap	1

Carburetor

Assembly Diagram

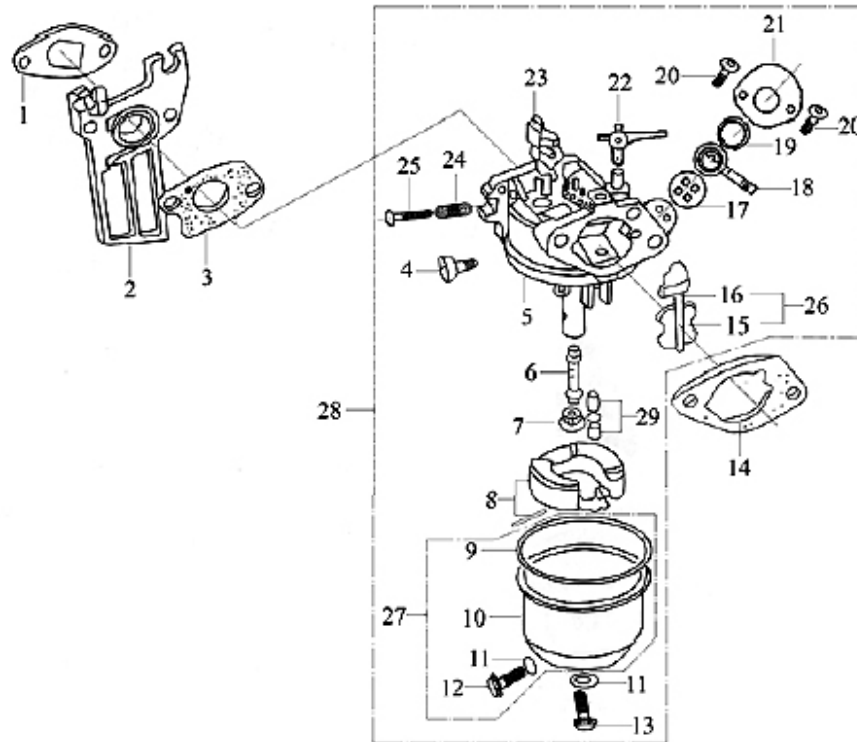

Note: When ordering parts from this list, specify: CARBURETOR ASSEMBLY and the ITEM No.

Parts List

Part	Description	Q'ty
1	Inlet Gasket	1
2	Connecting Block	1
3	Carburetor Gasket	1
4	Screw, Idle Adjustment	1
5	Chamber Bode, Mixture	1
6	Nozzle, Main	1
7	Jet, Main	1
8	Float	1
9	Float Chamber Gasket	1
10	Float Chamber	1
11	Washer	2
12	Float Chamber Drain Screw	1
13	Screw	1
14	Air Cleaner Gasket	1
15	Choke	1

Part	Description	Q'ty
16	Choke Stem	1
17	Washer, Air-proof	1
18	Throttle Lever	1
19	Washer	1
20	Screw, M4	2
21	Cover	1
22	Choke Switch	1
23	Throttle Unit	1
24	Spring, Mixture Adjustment Screw	1
25	Screw, Mixture Adjustment	1
26	Choke Unit	1
27	Float Chamber	1
28	Carburetor Assembly	1
29	Float Needle	1

Fuel Tank Assembly Diagram

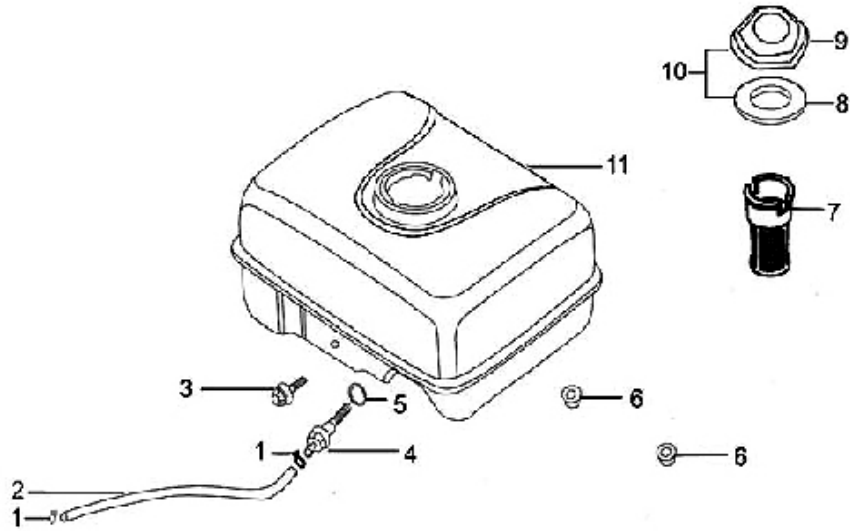

Note: When ordering parts from this list, specify: FUEL TANK ASSEMBLY and the ITEM No.

Parts List

Part	Description	Q'ty
1	Pipe Clamp	2
2	Pipe, Outlet	1
3	Bolt, M6x22	1
4	Connector	1
5	Packing Ring	1
6	Nut, M6	2
7	Filter Cup	1
8	Packing Ring	1
9	Fuel Filler Cap	1
10	Fuel Filler Cap with Packing Ring	1
11	Fuel Tank	1

Air Cleaner

Assembly Diagram

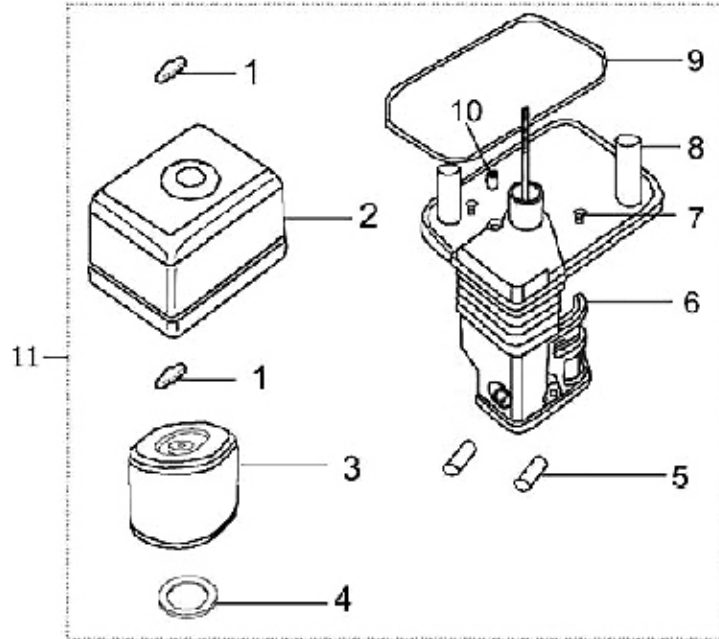

Note: When ordering parts from this list, specify: AIR CLEANER ASSEMBLY and the ITEM No.

Parts List

Part	Description	Q'ty
1	Wing Nut	2
2	Air Cleaner Cover	1
3	Filter Element	1
4	Washer	1
5	Sleeve A	2
6	Air Cleaner Housing	1
7	Screw, M5x12	2
8	Air Cleaner Base	1
9	Gasket	1
10	Sleeve B	1
11	Air Cleaner Assembly	1

Muffler

Assembly Diagram

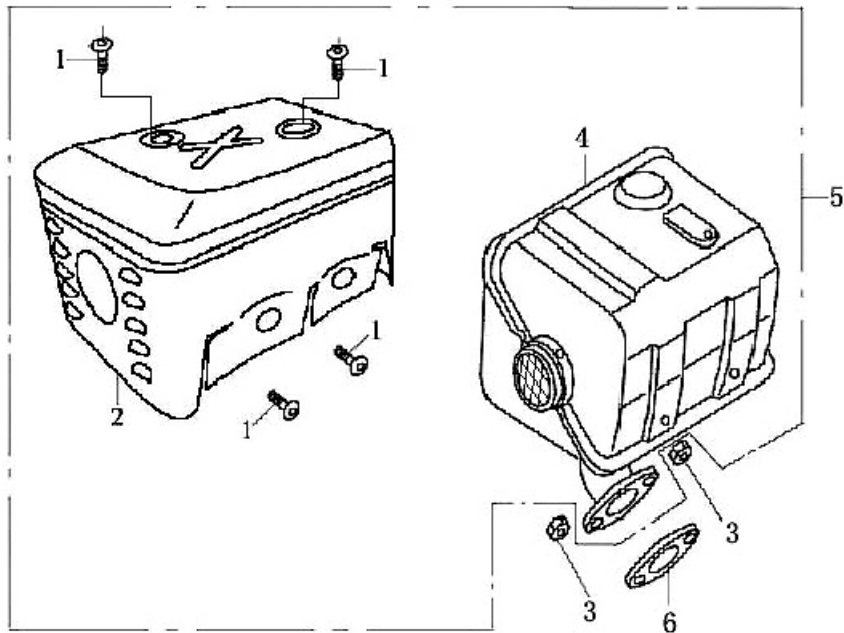

Note: When ordering parts from this list, specify: MUFFLER ASSEMBLY and the ITEM No.

Parts List

Part	Description	Q'ty
1	Screw, M5x8	4
2	Muffler Hood	1
3	Nut, M8	2
4	Muffler	1
5	Exhaust Muffler	1
6	Exhaust Gasket	1

Recoil Starter

Assembly Diagram

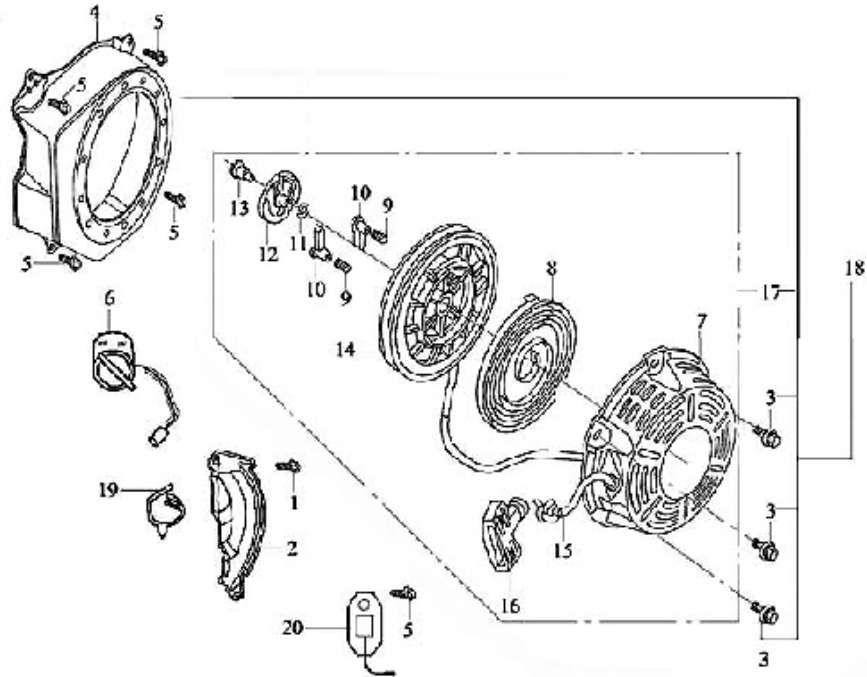

Note: When ordering parts from this list, specify: RECOIL STARTER ASSEMBLY and the ITEM No.

Parts List

Part	Description	Q'ty
1	Bolt, M6x22	1
2	Crankcase Side Plate Assy	1
3	Bolt, M6x18	3
4	Fan Hood Assy.	1
5	Bolt, M6x12	5
6	Switch, Engine	1
7	Casing	1
8	Spring, Spiral	1
9	Spring, Ratchet	2
10	Ratchet	2

Part	Description	Q'ty
11	Spring, Friction	1
12	Spring Lid	1
13	Screw, Set	1
14	Starter Wheel	1
15	Rope, Starter	1
16	Handle, Rope Pull	1
17	Recoil Starter	1
18	Recoil Starter Assembly	1
19	Clip, Plastic	1
20	Diode	1

Regulator Control Assembly Diagram

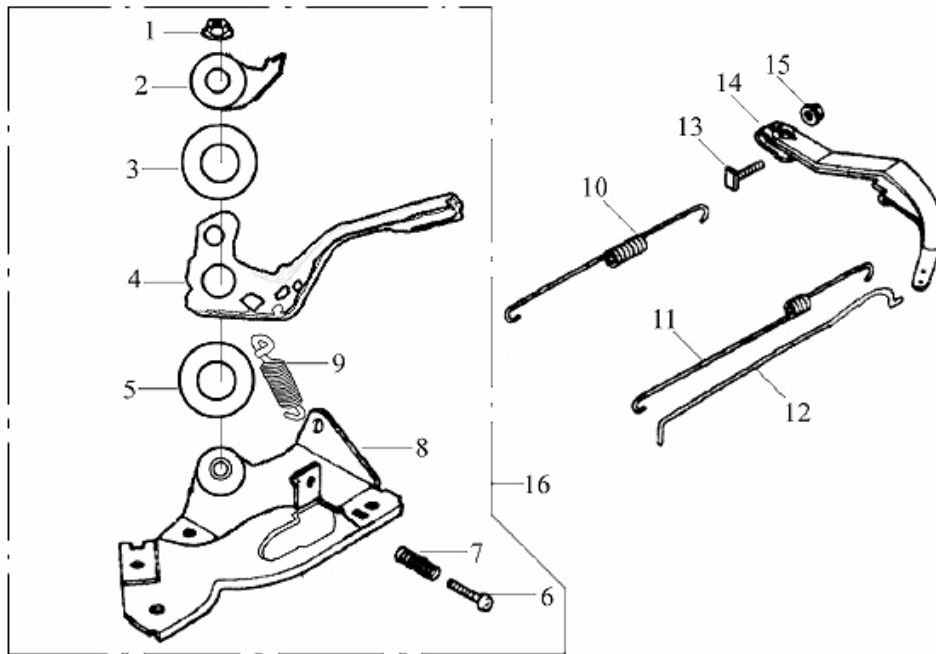

Note: When ordering parts from this list, specify: REGULATOR CONTROL ASSEMBLY and the ITEM No.

Parts List

Part	Description	Q'ty
1	Nut, M6	1
2	Panel, Setting	1
3	Spring Patch	1
4	Hand Grip	1
5	Washer	1
6	Bolt, M5x25	1
7	Spring, Regulating	1
8	Support Panel Assembly	1

Part	Description	Q'ty
9	Spring	1
10	Spring, Back	1
11	Spring, Fine Regulating	1
12	Rod, Pull	1
13	Bolt, Lock	1
14	Arm, Regulating	1
15	Nut, M6	1
16	Regulating Frame Assembly	1

Flywheel
Assembly Diagram

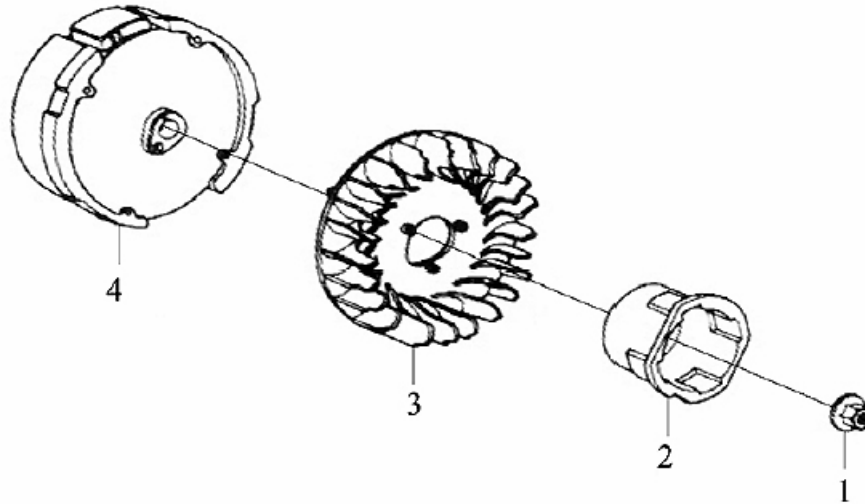

Note: When ordering parts from this list, specify: FLYWHEEL ASSEMBLY and the ITEM No.

Parts List

Part	Description	Q'ty
1	Nut, M14x1.5	1
2	Starting Flange	1
3	Flywheel Fan	1
4	Flywheel	1

Ignition Coil Assembly Diagram

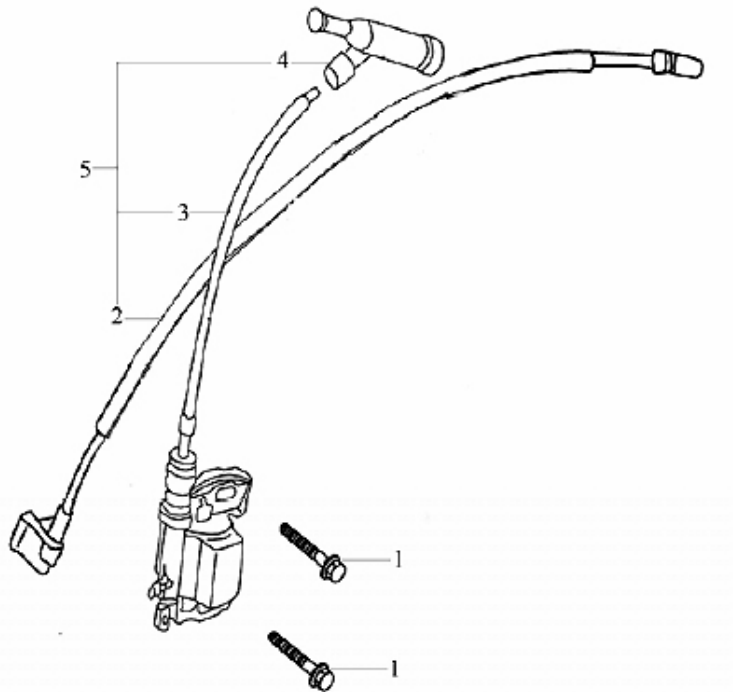

Note: When ordering parts from this list, specify: IGNITION COIL ASSEMBLY and the ITEM No.

Parts List

Part	Description	Q'ty
1	Screw, M6x22	2
2	Engine Stop Cable	1
3	Ignition Coil	1
4	Spark Plug Cap	1
5	Ignition Coil Assembly	1

Wiring Diagram

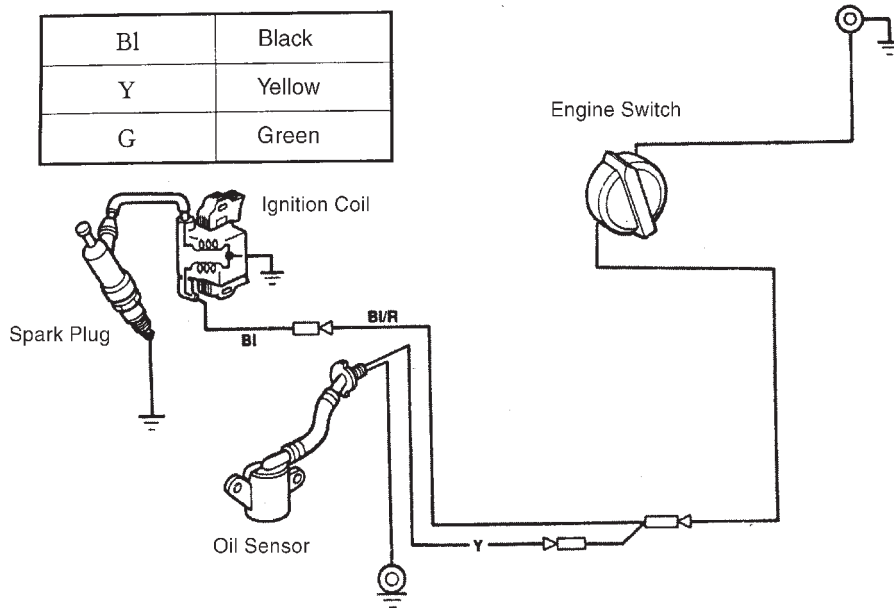

WARRANTY

CENTRAL MACHINERY®

LIMITED 90 DAY WARRANTY

Harbor Freight Tools Co. makes every effort to assure that its products meet high quality and durability standards, and warrants to the original purchaser that this product is free from defects in materials and workmanship for the period of ninety days from the date of purchase. This warranty does not apply to damage due directly or indirectly, to misuse, abuse, negligence or accidents, repairs or alterations outside our facilities, or to lack of maintenance. We shall in no event be liable for death, injuries to persons or property, or for incidental, contingent, special or consequential damages arising from the use of our product. Some states do not allow the exclusion or limitation of incidental or consequential damages, so the above limitation of exclusion may not apply to you. **THIS WARRANTY IS EXPRESSLY IN LIEU OF ALL OTHER WARRANTIES, EXPRESS OR IMPLIED, INCLUDING THE WARRANTIES OF MERCHANTABILITY AND FITNESS.**

To take advantage of this warranty, the product or part must be returned to us with transportation charges prepaid. Proof of purchase date and an explanation of the complaint must accompany the merchandise. If our inspection verifies the defect, we will either repair or replace the product at our election or we may elect to refund the purchase price if we cannot readily and quickly provide you with a replacement. We will return repaired products at our expense, but if we determine there is no defect, or that the defect resulted from causes not within the scope of our warranty, then you must bear the cost of returning the product.

This warranty gives you specific legal rights and you may also have other rights which vary from state to state.

3491 Mission Oaks Blvd. • PO Box 6009 • Camarillo, CA 93011 • (800) 444-3353

EMISSION CONTROL SYSTEM WARRANTY

California and United States Emission Control Defects Warranty Statement

The California Air Resources Board (herein CARB), the United States Environmental Protection Agency (herein EPA), and Harbor Freight Tools® (herein HFT) are pleased to explain the emission control system warranty on your 1995 and later Small Off-Road Engine (herein engine). In California, the engine must be designed, built and equipped to meet the State's stringent anti-smog standards. Elsewhere within the United States, new off-road, spark-ignition engines certified for model year 1997 and later, must meet similar standards set forth by the EPA. HFT must warrant the emission control system on your engine for the periods of time described below, provided there has been no abuse, neglect or improper maintenance of your engine.

Your emission control system may include parts such as the carburetor or fuel-injection system, and the ignition system. Also included may be hoses, belts, connectors and other emission-related assemblies.

Where a warrantable condition exists, HFT will repair your engine at no cost to you including diagnosis, parts and labor.

Manufacturer's Warranty Coverage

The 1995 and later engines are warranted for two (2) years. If any emission-related part on your engine is defective, the part will be repaired or replaced by HFT.

Harbor Freight Tools Emission Control Defects Warranty Coverage

Engines are warranted for a period of two (2) years relative to emission control parts defects, subject to the provisions set forth below. If any emission related part on your engine is defective, the part will be repaired or replaced by HFT.

Owner's Warranty Responsibilities

- As the engine owner, you are responsible for the performance of the required maintenance listed in your Owner's Manual. HFT recommends that you retain all receipts covering maintenance on your engine, but HFT cannot deny warranty solely for the lack of receipts or for your failure to ensure the performance of all scheduled maintenance.
- As the engine owner, you should, however, be aware that HFT may deny you warranty coverage if your engine or a part has failed due to abuse, neglect, improper maintenance, or unapproved modifications.
- You are responsible for shipping your engine to a HFT warranty station as soon as a problem exists. Contact the HFT Customer Service department at the number below to make shipping arrangements. The warranty repairs should be completed in a reasonable amount of time, not to exceed 30 days.

If you have any questions regarding your warranty rights and responsibilities, you should contact the Harbor Freight Tools

Customer Service Department at 1-800-444-3353.

Harbor Freight Tools Emission Control Defects Warranty Provisions

1. Length of Coverage

HFT warrants to a first retail purchaser and each subsequent purchaser that the engine is free from defects in materials and workmanship that cause the failure of warranted parts for a period of two (2) years after the date of delivery to the first retail purchaser.

2. No Charge Repair or Replacement

Repair or replacement of any warranted part will be performed at no charge to the owner if the work is performed through a warranty station authorized by HFT. For emissions warranty service, contact the HFT Customer Service Department at 1-800-444-3353.

3. Consequential Damages Coverage

Coverage under this warranty shall also extend to the failure of any engine components caused by the failure of any warranted part while it is still covered under this warranty.

Equivalent in durability and performance, may be used in performance of maintenance or repairs. The owner is responsible for commissioning a qualified technician/mechanic to perform all required maintenance, as outlined in the **Inspection, Cleaning, and Maintenance** section in this manual.

EMISSION CONTROL SYSTEM WARRANTY (CONTINUED)

4. Coverage Exclusions

Warranty claims shall be filed in accordance with the provisions of the HFT warranty policy explained in the box at the top of the previous page. HFT shall not be liable for any loss of use of the engine, for any alternative usage, for any damage to goods, loss of time, or inconvenience. Warranty coverage shall also be excluded for any part which fails, malfunctions, or is damaged due to failure to follow the maintenance and operating instructions set forth in the Owner's Manual including, but not limited to:

- (a) use of parts which are not authorized by HFT
- (b) improper installation, adjustment or repair of the engine or of any warranted part unless performed by an authorized warranty center
- (c) failure to follow recommendations on fuel use contained in the Owner's Manual
- (d) improper or inadequate maintenance of any warranted parts
- (e) repairs performed outside of the authorized warranty service dealers
- (f) alterations by changing, adding to or removing parts from the engine.

5. Service and Maintenance

Component parts which are not scheduled for replacement as required maintenance or are scheduled only for regular inspection to the effect of "repair or replace as necessary" are warranted for the warranty period. Any warranted part which is scheduled for replacement as required maintenance is warranted for the period of time up to the first scheduled replacement point for that part. Any replacement part, provided it is equivalent in durability and performance, may be used in performance of maintenance or repairs. The owner is responsible for commissioning a qualified technician/mechanic to perform all required maintenance, as outlined in the **Inspection, Cleaning, and Maintenance** section on page 17 of this manual.

6. Warranted Parts

- 1) Fuel Metering System**
 - i) Carburetor and its internal parts.
 - ii) Fuel pump (if so equipped).
 - iii) Cold start enrichment system.
- 2) Air Induction System**
 - i) Intake pipe/manifold.
 - ii) Air cleaner.
- 3) Ignition System**
 - i) Spark plug.
 - ii) Magneto ignition system.
- 4) Catalyst System (if so equipped)**
 - i) Exhaust pipe stud.
 - ii) Muffler.
 - iii) Catalytic converter (if so equipped).
- 5) Miscellaneous items Used in Above Systems**
 - i) Vacuum, temperature and time sensitive valves and switches.
 - ii) Hoses, belts, connectors, and assemblies.

Free Manuals Download Website

<http://myh66.com>

<http://usermanuals.us>

<http://www.somanuals.com>

<http://www.4manuals.cc>

<http://www.manual-lib.com>

<http://www.404manual.com>

<http://www.luxmanual.com>

<http://aubethermostatmanual.com>

Golf course search by state

<http://golfingnear.com>

Email search by domain

<http://emailbydomain.com>

Auto manuals search

<http://auto.somanuals.com>

TV manuals search

<http://tv.somanuals.com>