

CENTRAL MACHINERY®

60" FARM JACK

Model 66183

SET UP AND OPERATING INSTRUCTIONS



Distributed exclusively by Harbor Freight Tools®.

3491 Mission Oaks Blvd., Camarillo, CA 93011

Visit our website at: <http://www.harborfreight.com>



**Read this material before using this product.
Failure to do so can result in serious injury.
SAVE THIS MANUAL.**

Copyright© 2008 by Harbor Freight Tools®. All rights reserved. No portion of this manual or any artwork contained herein may be reproduced in any shape or form without the express written consent of Harbor Freight Tools. Diagrams within this manual may not be drawn proportionally. Due to continuing improvements, actual product may differ slightly from the product described herein. Tools required for assembly and service may not be included.

For technical questions or replacement parts, please call 1-800-444-3353.

SAVE THIS MANUAL

Keep this manual for the safety warnings and precautions, assembly, operating, inspection, maintenance and cleaning procedures. Write the product's serial number in the back of the manual near the assembly diagram (or month and year of purchase if product has no number). Keep this manual and the receipt in a safe and dry place for future reference.

IMPORTANT SAFETY INFORMATION

In this manual, on the labeling, and all other information provided with this product:



This is the safety alert symbol. It is used to alert you to potential personal injury hazards. Obey all safety messages that follow this symbol to avoid possible injury or death.

DANGER

DANGER indicates a hazardous situation which, if not avoided, will result in death or serious injury.

WARNING

WARNING indicates a hazardous situation which, if not avoided, could result in death or serious injury.

CAUTION

CAUTION, used with the safety alert symbol, indicates a hazardous situation which, if not avoided, could result in minor or moderate injury.

NOTICE

NOTICE is used to address practices not related to personal injury.

CAUTION

CAUTION, without the safety alert symbol, is used to address practices not related to personal injury.

General Safety Rules



WARNING Read all safety warnings and instructions.

Failure to follow the warnings and instructions may result in serious injury.

Save all warnings and instructions for future reference.

1. **Work area safety**
 - a. **Keep work area clean and well lit.** *Cluttered or dark areas invite accidents.*
 - b. **Keep children and bystanders away while operating tools.** *Distractions can cause you to lose control.*
2. **Personal safety**
 - a. **Stay alert, watch what you are doing and use common sense when using a tool. Do not use tools while you are tired or under the influence of drugs, alcohol or medication.** *A moment of inattention while operating a tool may result in serious personal injury.*
 - b. **Use personal protective equipment. Always wear eye protection.** *Safety equipment such as dust mask, non-skid safety shoes, hard hat, or hearing protection used for appropriate conditions will reduce personal injuries.*

- c. **Dress properly. Do not wear loose clothing or jewelry. Keep your hair, clothing and gloves away from moving parts.** *Loose clothes, jewelry or long hair can be caught in moving parts.*
 - d. **Only use safety equipment that has been approved by an appropriate standards agency.** *Unapproved safety equipment may not provide adequate protection. Eye protection must be ANSI-approved and breathing protection must be NIOSH-approved for the specific hazards in the work area.*
3. **Tool use and care**
- a. **Do not force the tool. Use the correct tool for your application.** *The correct tool will do the job better and safer at the rating for which it was designed.*
 - b. **Store idle tools out of the reach of children and do not allow persons unfamiliar with it or these instructions to operate the tool.** *Tools are dangerous in the hands of untrained users.*
 - c. **Maintain your tools. Check for misalignment or binding of moving parts, breakage of parts and any other condition that may affect the tool's operation. If damaged, have the tool repaired before use.** *Many accidents are caused by poorly maintained tools.*
 - d. **Use the tool in accordance with these instructions, taking into account the working conditions and the work to be performed.** *Use of the tool for operations different from those intended could result in a hazardous situation.*

Farm Jack Safety Warnings

1. **Be aware of dynamic loading!** Sudden load movement may briefly create excess load causing product failure.
2. Use the Jack on solid, level surfaces, capable of supporting the weight of the Jack, equipment being lifted, and operator.
3. Do not exceed the lifting capacity (7,000 pounds) of the Jack.
4. Maintain labels and nameplates on the tool. These carry important safety information. If unreadable or missing, contact Harbor Freight Tools for a replacement.
5. This product is not a toy. Keep it out of reach of children.
6. The warnings, precautions, and instructions discussed in this instruction manual cannot cover all possible conditions and situations that may occur. It must be understood by the operator that common sense and caution are factors which cannot be built into this product, but must be supplied by the operator.

SPECIFICATIONS

Jack Capacity	7,000 Pounds
Maximum Lift	59-1/4"
Minimum Height	6"

UNPACKING

When unpacking, make sure that the item is intact and undamaged. If any parts are missing or broken, please call Harbor Freight Tools at the number shown on the cover of this manual as soon as possible.

Note: For additional information regarding the parts listed in the following pages, refer to the Assembly Diagram near the end of this manual.

OPERATING INSTRUCTIONS



Read the **ENTIRE IMPORTANT SAFETY INFORMATION** section at the beginning of this manual including all text under subheadings therein before set up or use of this product.

1. Designate a work area that is clean and well-lit. The work area must not allow access by children or pets to prevent injury and distraction.
2. Use the Jack on solid, level surfaces, capable of supporting the weight of the Jack, equipment being lifted, and operator.
3. To increase stability, the Jack can be bolted to a thick board, metal plate, or a cement surface. Use the three mounting holes on the Base as a template to mark the location where three 1/2" diameter holes will be drilled into the surface. Drill and clean out the three holes. Align the three mounting holes with the three drilled holes and secure the Jack to the floor using

masonry expansion anchors (not included). Only use materials capable of bearing the weight of the Jack and load being lifted.

4. To raise loads, pull the Ratchet Control Lever (10) up until the mechanism clicks and the Latch engages.
5. Place the jack's lift nose completely under the object being lifted.
6. Slowly pump the handle to raise the load. Keep a firm grip on the handle while operating the jack.
7. **⚠ Caution!** To avoid injury keep hands away from the Lift Nose when raising a load. Keep bystanders and pets away when a load is raised. Do not work under a raised load.
8. After the load is raised to the desired height, insert a grade 5, 1/2 inch bolt (sold separately) through the hole in the Lift Column (2) immediately below the lifting mechanism.

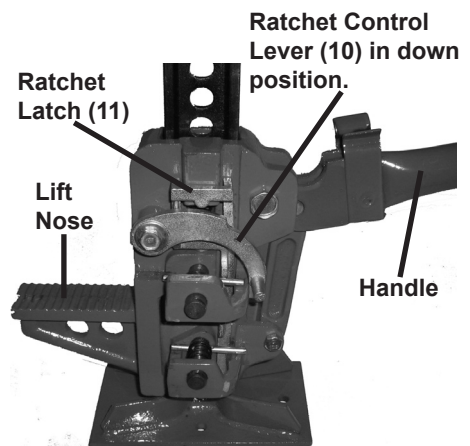

9. Insert additional supports to make sure the load is properly supported at the lift point to prevent shifting.
10. To lower the load; move the Ratchet Control Lever to the down position,

and pump the Handle up and down slowly. The latch will click as the load is lowered. Continue pumping the Handle until the load rests on the ground.

11. Clean, then store the tool indoors out of children's reach.

USER-MAINTENANCE INSTRUCTIONS



Procedures not specifically explained in this manual must be performed only by a qualified technician.



TO PREVENT SERIOUS INJURY

FROM TOOL FAILURE:

Do not use damaged equipment. If abnormal noise occurs, have the problem corrected before further use.

OR DISTRIBUTOR MAKES ANY REPRESENTATION OR WARRANTY OF ANY KIND TO THE BUYER THAT HE OR SHE IS QUALIFIED TO MAKE ANY REPAIRS TO THE PRODUCT, OR THAT HE OR SHE IS QUALIFIED TO REPLACE ANY PARTS OF THE PRODUCT. IN FACT, THE MANUFACTURER AND/OR DISTRIBUTOR EXPRESSLY STATES THAT ALL REPAIRS AND PARTS REPLACEMENTS SHOULD BE UNDERTAKEN BY CERTIFIED AND LICENSED TECHNICIANS, AND NOT BY THE BUYER. THE BUYER ASSUMES ALL RISK AND LIABILITY ARISING OUT OF HIS OR HER REPAIRS TO THE ORIGINAL PRODUCT OR REPLACEMENT PARTS THERETO, OR ARISING OUT OF HIS OR HER INSTALLATION OF REPLACEMENT PARTS THERETO.

Cleaning, Maintenance, and Lubrication

1. **BEFORE EACH USE**, inspect the general condition of the tool. Check for loose screws, misalignment or binding of moving parts, cracked or broken parts and any other condition that may affect its safe operation.
2. **PERIODICALLY**, lubricate moving parts of the Jack with lubricating oil.
3. **AFTER USE**, clean the tool with clean cloth.

PLEASE READ THE FOLLOWING CAREFULLY

THE MANUFACTURER AND/OR DISTRIBUTOR HAS PROVIDED THE PARTS LIST AND ASSEMBLY DIAGRAM IN THIS MANUAL AS A REFERENCE TOOL ONLY. NEITHER THE MANUFACTURER

PARTS LIST

Part	Description	Qty
1	Runner	1
2	Lift Column	1
3	Connecting Rod	1
4	Rocker with Handle	1
5	Washer	1
6	Nut	1
7	Pin	1
8	Screw	1
9	Washer	1
10	Ratchet Control Lever	1
11	Ratchet Latch	1
12	Bolt	1
13	Nut	1

PARTS LIST

Part	Description	Qty
14	Spring Washer	1
15	Base	1
16	Bolt	1
17	Bolt	1
18	Spring	1
19	Pin	2
20	Reverse Rod	2
21	Spring	1
22	Spring	1
23	Washer	1
24	Nut	1
25	Runner	1
26	Washer	1

Record Product's Serial Number Here: _____

Note: If product has no serial number, record month and year of purchase instead.

Note: Some parts are listed and shown for illustration purposes only, and are not available individually as replacement parts.

DIAGRAM

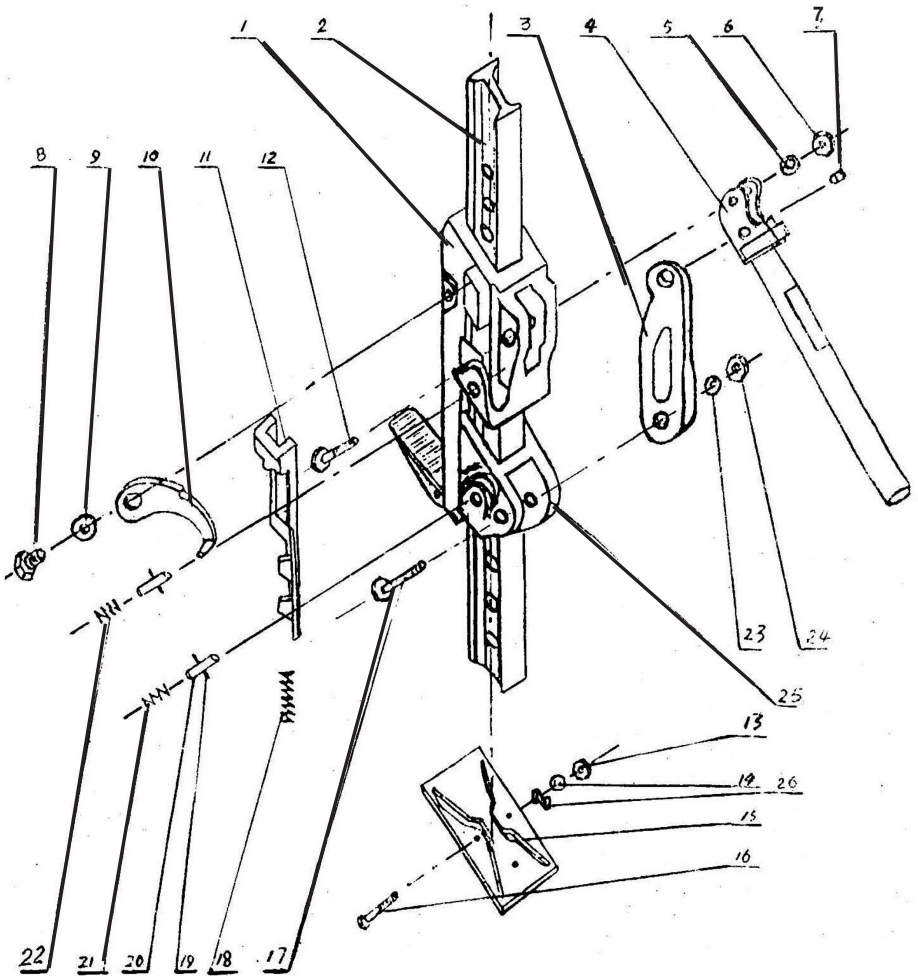

LIMITED 90 DAY WARRANTY

Harbor Freight Tools Co. makes every effort to assure that its products meet high quality and durability standards, and warrants to the original purchaser that this product is free from defects in materials and workmanship for the period of 90 days from the date of purchase. This warranty does not apply to damage due directly or indirectly, to misuse, abuse, negligence or accidents, repairs or alterations outside our facilities, criminal activity, improper installation, normal wear and tear, or to lack of maintenance. We shall in no event be liable for death, injuries to persons or property, or for incidental, contingent, special or consequential damages arising from the use of our product. Some states do not allow the exclusion or limitation of incidental or consequential damages, so the above limitation of exclusion may not apply to you. THIS WARRANTY IS EXPRESSLY IN LIEU OF ALL OTHER WARRANTIES, EXPRESS OR IMPLIED, INCLUDING THE WARRANTIES OF MERCHANTABILITY AND FITNESS.

To take advantage of this warranty, the product or part must be returned to us with transportation charges prepaid. Proof of purchase date and an explanation of the complaint must accompany the merchandise. If our inspection verifies the defect, we will either repair or replace the product at our election or we may elect to refund the purchase price if we cannot readily and quickly provide you with a replacement. We will return repaired products at our expense, but if we determine there is no defect, or that the defect resulted from causes not within the scope of our warranty, then you must bear the cost of returning the product.

This warranty gives you specific legal rights and you may also have other rights which vary from state to state.

3491 Mission Oaks Blvd. • PO Box 6009 • Camarillo, CA 93011 • (800) 444-3353

Free Manuals Download Website

<http://myh66.com>

<http://usermanuals.us>

<http://www.somanuals.com>

<http://www.4manuals.cc>

<http://www.manual-lib.com>

<http://www.404manual.com>

<http://www.luxmanual.com>

<http://aubethermostatmanual.com>

Golf course search by state

<http://golfingnear.com>

Email search by domain

<http://emailbydomain.com>

Auto manuals search

<http://auto.somanuals.com>

TV manuals search

<http://tv.somanuals.com>