

Owner's Manual & Safety Instructions

Save This Manual Keep this manual for the safety warnings and precautions, assembly, operating, inspection, maintenance and cleaning procedures. Write the product's serial number in the back of the manual near the assembly diagram (or month and year of purchase if product has no number). Keep this manual and the receipt in a safe and dry place for future reference.

PREDATORTM E N G I N E S

212cc Horizontal Engine

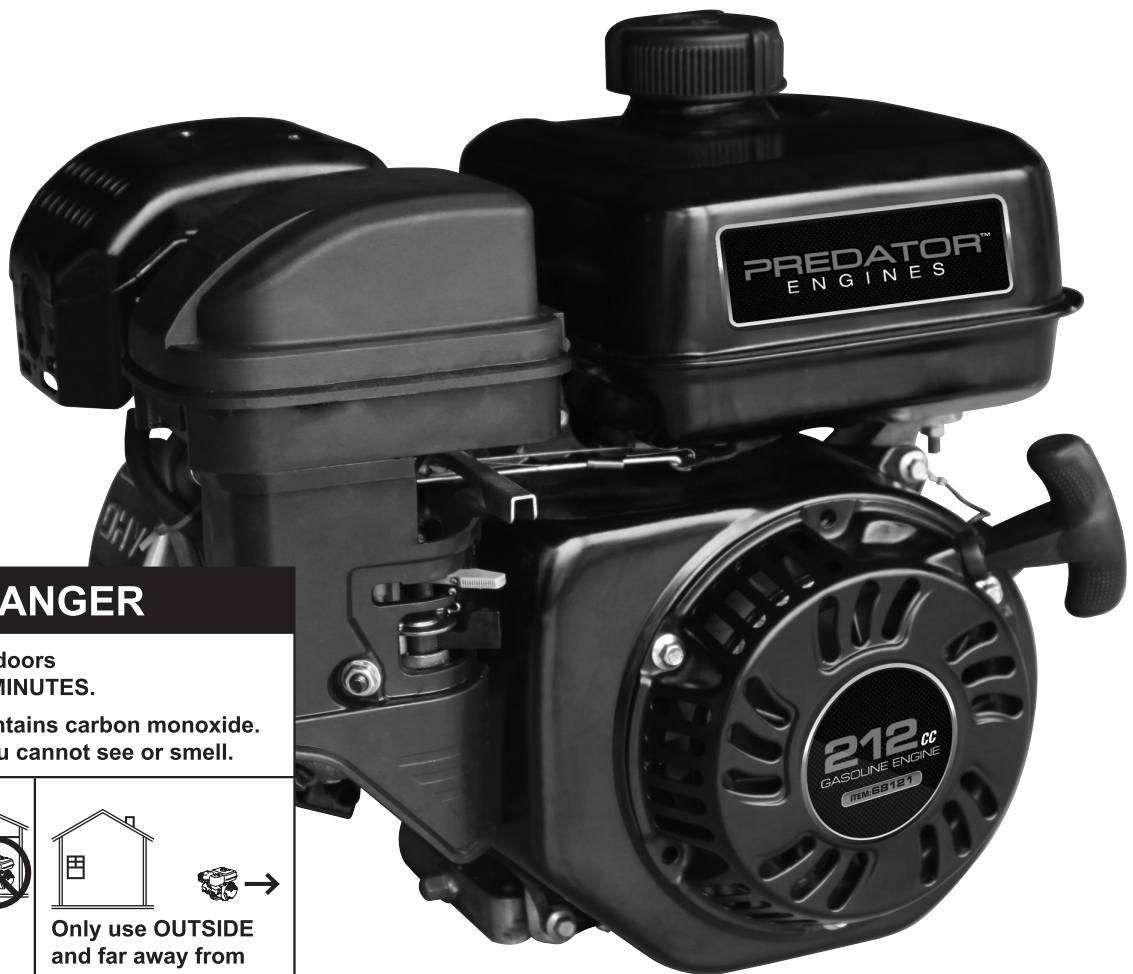

⚠ DANGER

Using an engine indoors
CAN KILL YOU IN MINUTES.

Engine exhaust contains carbon monoxide.
This is a poison you cannot see or smell.



NEVER use inside
a home or garage,
EVEN IF doors and
windows are open.

Only use **OUTSIDE**
and far away from
windows, doors,
and vents.

REV 13I

Visit our website at: <http://www.harborfreight.com>
Email our technical support at: predator@harborfreight.com

ITEMS 69727 / 69730

When unpacking, make sure that the product is intact and undamaged.
If any parts are missing or broken,
please call 1-800-520-0882 as soon as possible.

Copyright© 2012 by Harbor Freight Tools®. All rights reserved.
No portion of this manual or any artwork contained herein may be reproduced in
any shape or form without the express written consent of Harbor Freight Tools.
Diagrams within this manual may not be drawn proportionally. Due to continuing
improvements, actual product may differ slightly from the product described herein.
Tools required for assembly and service may not be included.

⚠ WARNING

**Read this material before using this product.
Failure to do so can result in serious injury.
SAVE THIS MANUAL.**

Table of Contents





| | | | |
|----------------------|---|--------------------------------|----|
| Specifications | 2 | Maintenance | 12 |
| Safety | 3 | Troubleshooting | 16 |
| Setup | 6 | Warranties | 18 |
| Operation | 8 | Parts Lists and Diagrams | 20 |

Specifications







| | | |
|--|------------|---|
| Displacement | | 212cc |
| Engine Type | | Horizontal Single Cylinder 4 stroke OHV 69727: Meets EPA phase III and CARB emissions standards 69730: Meets EPA phase III emissions standards |
| Cooling System | | Forced air cooled |
| Fuel | Type | 87+ octane unleaded gasoline |
| | Capacity | 0.9 Gallon (3.6 Liter) |
| Engine Oil | Type SAE | 10W-30 above 32° F 5W-30 at 32° F or below |
| | Capacity | 0.5 Quart |
| Run Time @ 50% Load with full tank | | 3 hr. |
| Sound Level at 22 feet | | 104 dB |
| Bore x Stroke | | 70 mm x 55 mm |
| Compression Ratio | | 8.5:1 |
| Rotation viewed from PTO (power takeoff - the output shaft) | | Counterclockwise |
| Shaft | Shaft | 3/4" x 2.43" |
| | Keyway | 3/16" (4.76 mm) |
| | End Tapped | 5/16" - 24 UNF |
| Spark Plug | Type | NGK® BP-6ES NHSP® / Torch® F6TC |
| | Gap | 0.7 - 0.8 mm |
| Valve Clearance | Intake | 0.10 - 0.15 mm |
| | Exhaust | 0.15 - 0.20 mm |
| Speed | Idle | 1,800 ±50 RPM |

PREDATOR™
E N G I N E S

WARNING SYMBOLS AND DEFINITIONS

| | |
|---|--|
|  | This is the safety alert symbol. It is used to alert you to potential personal injury hazards. Obey all safety messages that follow this symbol to avoid possible injury or death. |
|  | Indicates a hazardous situation which, if not avoided, will result in death or serious injury. |
|  | Indicates a hazardous situation which, if not avoided, could result in death or serious injury. |
|  | Indicates a hazardous situation which, if not avoided, could result in minor or moderate injury. |
|  | Addresses practices not related to personal injury. |

Symbol Definitions

| Symbol | Property or Statement | Symbol | Property or Statement |
|---|---|---|--|
| RPM | Revolutions Per Minute |  | WARNING marking concerning Risk of Respiratory Injury. Operate engine OUTSIDE and far away from windows, doors, and vents. |
| HP | Horsepower |  | WARNING marking concerning Risk of Fire while handling fuel. Do not smoke while handling fuel. |
|  | WARNING marking concerning Risk of Eye Injury. Wear ANSI-approved safety goggles with side shields. |  | WARNING marking concerning Risk of Fire. Do not refuel while operating. Keep flammable objects away from engine. |
|  | Read the manual before set-up and/or use. | | |
|  | WARNING marking concerning Risk of Hearing Loss. Wear hearing protection. | | |

Safety Warnings



WARNING! Read all instructions.

Failure to follow all instructions listed below may result in fire, serious injury and/or DEATH.

The warnings and precautions discussed in this manual cannot cover all possible conditions and situations that may occur. It must be understood by the operator that common sense and caution are factors which cannot be built into this product, but must be supplied by the operator.

SAVE THESE INSTRUCTIONS

Set up Precautions

1. Gasoline fuel and fumes are flammable, and potentially explosive. Use proper fuel storage and handling procedures. Do not store fuel or other flammable materials nearby.
2. Have multiple ABC class fire extinguishers nearby.
3. Operation of this equipment may create sparks that can start fires around dry vegetation. A spark arrestor may be required. The operator should contact local fire agencies for laws or regulations relating to fire prevention requirements.
4. Set up and use only on a flat, level, well-ventilated surface.
5. Wear ANSI-approved safety goggles, heavy-duty work gloves, and dust mask/respirator during set up.
6. Use only lubricants and fuel recommended in the Specifications chart of this manual.

Operating Precautions

1.  **CARBON MONOXIDE HAZARD**
Using an engine indoors CAN KILL YOU IN MINUTES.
Engine exhaust contains carbon monoxide. This is a poison you cannot see or smell.

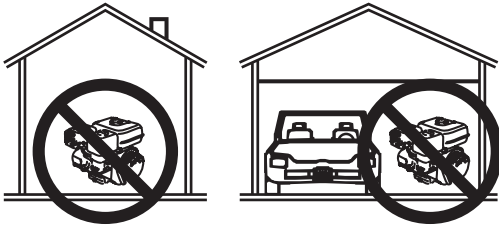

NEVER use inside a home or garage, EVEN IF doors and windows are open.

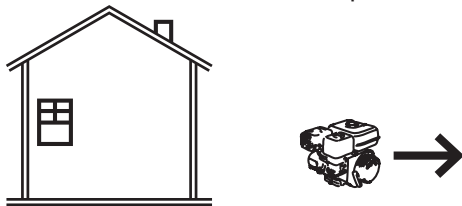

Only use OUTSIDE and far away from windows, doors, and vents.

2. Keep children away from the equipment, especially while it is operating.
3. Keep all spectators at least six feet from the Engine during operation.
4. Fire Hazard! Do not fill gas tank while engine is running. Do not operate if gasoline has been spilled. Clean spilled gasoline before starting engine. Do not operate near pilot light or open flame.
5. Do not touch engine during use. Let engine cool down after use.
6. Never store fuel or other flammable materials near the engine.
7. Only use a suitable means of transport and lifting devices with sufficient weight bearing capacity when transporting the Engine.
8. Secure the Engine on transport vehicles to prevent the tool from rolling, slipping, and tilting.
9. Industrial applications must follow OSHA requirements.
10. Do not leave the equipment unattended when it is running. Turn off the equipment (and remove safety keys, if available) before leaving the work area.
11. Engine can produce high noise levels. Prolonged exposure to noise levels above 85 dBA is hazardous to hearing. Always wear ear protection when operating or working around the gas engine while it is operating.
12. Wear ANSI-approved safety glasses, hearing protection, and NIOSH-approved dust mask/respirator under a full face shield along with steel-toed work boots during use.
13. People with pacemakers should consult their physician(s) before use. Electromagnetic fields in close proximity to a heart pacemaker could cause pacemaker interference or pacemaker failure. Caution is necessary when near the engine's magneto or recoil starter.
14. Use only accessories that are recommended by Harbor Freight Tools for your model. Accessories that may be suitable for one piece of equipment may become hazardous when used on another piece of equipment.
15. Do not operate in explosive atmospheres, such as in the presence of flammable liquids, gases, or dust. Gasoline-powered engines may ignite the dust or fumes.
16. Stay alert, watch what you are doing and use common sense when operating this piece of equipment. Do not use this piece of equipment while tired or under the influence of drugs, alcohol or medication.
17. Do not overreach. Keep proper footing and balance at all times. This enables better control of the equipment in unexpected situations.
18. Use this equipment with both hands only. Using equipment with only one hand can easily result in loss of control.
19. Dress properly. Do not wear loose clothing or jewelry. Keep hair, clothing and gloves away from moving parts. Loose clothes, jewelry or long hair can be caught in moving parts.

Operating Precautions (cont.)

20. Parts, especially exhaust system components, get very hot during use. Stay clear of hot parts.
21. Do not cover the engine or equipment during operation.
22. Keep the equipment, engine, and surrounding area clean at all times.
23. Use the equipment, accessories, etc., in accordance with these instructions and in the manner intended for the particular type of equipment, taking into account the working conditions and the work to be performed. Use of the equipment for operations different from those intended could result in a hazardous situation.
24. Do not operate the equipment with known leaks in the engine's fuel system.
25. This product contains or, when used, produces a chemical known to the State of California to cause cancer and birth defects or other reproductive harm. (California Health & Safety Code § 25249.5, *et seq.*)
26. When spills of fuel or oil occur, they must be cleaned up immediately. Dispose of fluids and cleaning materials as per any local, state, or federal codes and regulations. Store oil rags in a bottom-ventilated, covered, metal container.
27. Keep hands and feet away from moving parts. Do not reach over or across equipment while operating.
28. Before use, check for misalignment or binding of moving parts, breakage of parts, and any other condition that may affect the equipment's operation. **If damaged, have the equipment serviced before using.** Many accidents are caused by poorly maintained equipment.
29. Use the correct equipment for the application. Do not modify the equipment and do not use the equipment for a purpose for which it is not intended.

Service Precautions

1. **Before service, maintenance, or cleaning:**
 - a. Turn the engine switch to its "OFF" position.
 - b. Allow the engine to completely cool.
 - c. Then, remove the spark plug cap from the spark plug.
2. Keep all safety guards in place and in proper working order. Safety guards include muffler, air cleaner, mechanical guards, and heat shields, among other guards.
3. **Do not alter or adjust any part of the equipment or its engine that is sealed by the manufacturer or distributor. Only a qualified service technician may adjust parts that may increase or decrease governed engine speed.**
4. Wear ANSI-approved safety goggles, heavy-duty work gloves, and dust mask/respirator during service.
5. Maintain labels and nameplates on the equipment. These carry important information. If unreadable or missing, contact Harbor Freight Tools for a replacement.
6. Have the equipment serviced by a qualified repair person using only identical replacement parts. This will ensure that the safety of the equipment is maintained. Do not attempt any service or maintenance procedures not explained in this manual or any procedures that you are uncertain about your ability to perform safely or correctly.
7. Store equipment out of the reach of children.

8. Follow scheduled engine and equipment maintenance.

Refueling:

1. Do not smoke, or allow sparks, flames, or other sources of ignition around the equipment, especially when refuelling.
2. Do not refill the fuel tank while the engine is running or hot.
3. **TO PREVENT FUEL LEAKAGE AND FIRE HAZARD, do not fill fuel above the bottom of fuel strainer.**

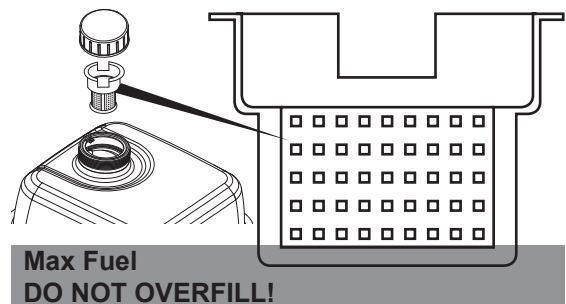

4. Do not fill fuel tank to the top. Leave a little room for the fuel to expand as needed.
5. Refuel in a well-ventilated area only.
6. Wipe up any spilled fuel and allow excess to evaporate before starting engine. **To prevent FIRE, do not start the engine while the smell of fuel hangs in the air.**



SAVE THESE INSTRUCTIONS.

Set Up



Read the **ENTIRE IMPORTANT SAFETY INFORMATION** section at the beginning of this manual including all text under subheadings therein before set up or use of this product.

!WARNING

TO PREVENT SERIOUS INJURY:

Operate only with proper spark arrestor installed.

Operation of this equipment may create sparks that can start fires around dry vegetation.

A spark arrestor may be required.

The operator should contact local fire agencies for laws or regulations relating to fire prevention requirements.

For item 69727: The emission control system for this Engine is warranted for standards set by the U.S. Environmental Protection Agency and by the California Air Resources Board (also known as CARB). For warranty information, refer to the last pages of this manual.

For item 69730: The emission control system for this Engine is warranted for standards set by the U.S. Environmental Protection Agency. For warranty information, refer to the last pages of this manual.

WARNING! DO NOT INSTALL THIS ENGINE ON A VEHICLE.

NOT FOR HIGHWAY USE. FOLLOW ALL APPLICABLE LAWS FOR INSTALLATION AND USE.

Engine Controls

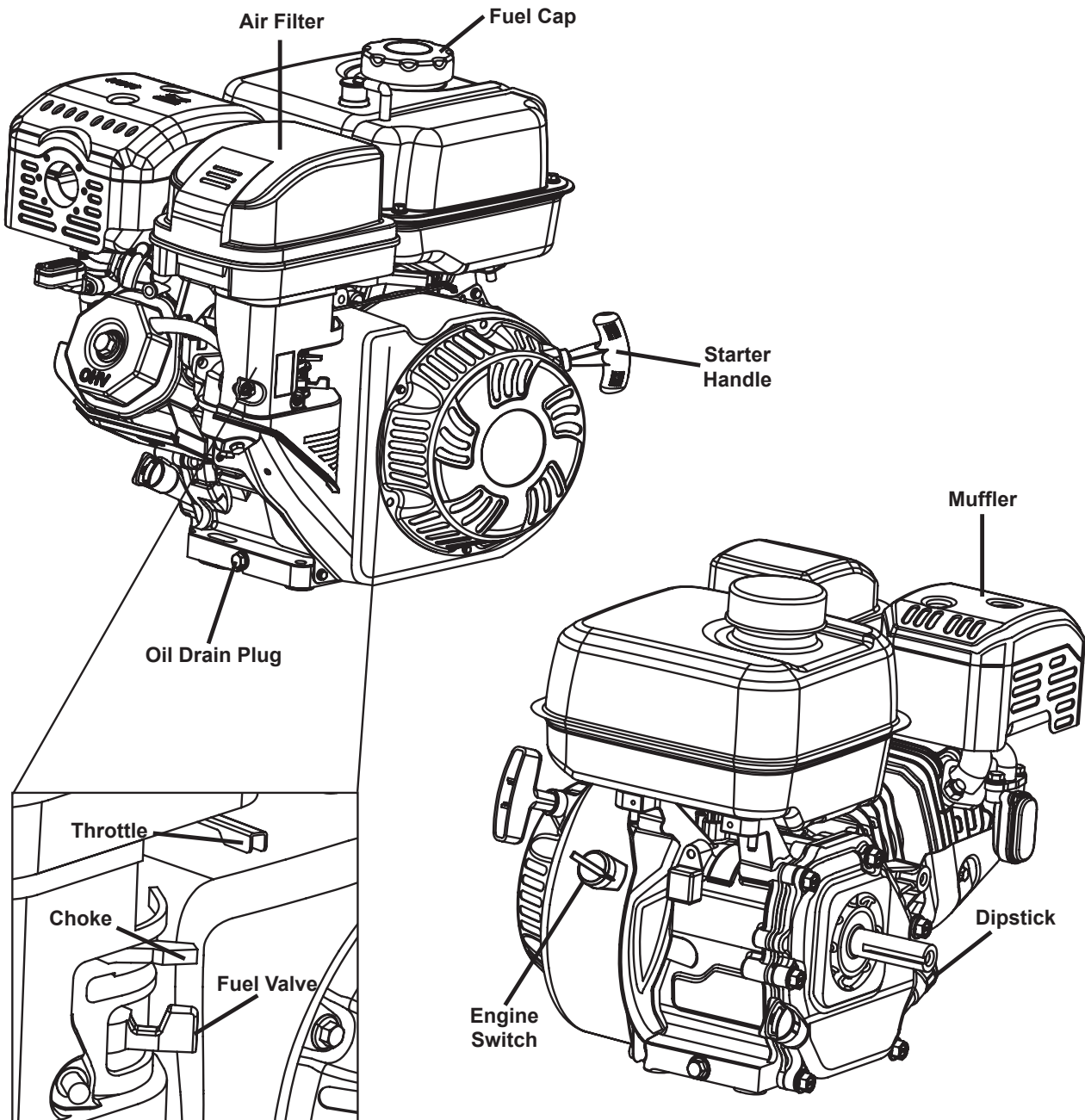

High Altitude Operation Above 3000 feet

At high altitudes, the engine's carburetor, governor (if so equipped), and any other parts that control the fuel-air ratio will need to be adjusted by a qualified mechanic to allow efficient high-altitude use and to prevent damage to the engine and any other devices used with this product.

The fuel system on this engine may be influenced by operation at higher altitudes.

Proper operation can be ensured by installing an altitude kit at altitudes higher than 3000 ft. above sea level.

At elevations above 8000 ft, the engine may experience decreased performance, even with the proper main jet.

Operating this engine without the proper altitude kit installed may increase the engine's emissions and decrease fuel economy and performance. The kit should be installed by a qualified mechanic.

⚠WARNING! TO PREVENT SERIOUS INJURY FROM FIRE:

Follow kit procedures in a well-ventilated area away from ignition sources.

If the engine is hot from use, shut the engine off and wait for it to cool before proceeding. Do not smoke.

NOTICE Warranty void if necessary adjustments are not made for high altitude use.

High Altitude Kit Installation Instructions

1. Turn off the engine.
2. Close the fuel valve.
3. Place a bowl under the fuel cup to catch any spilled fuel.
4. Unthread the bolt holding the fuel cup.

CAUTION! Carburetor bowl may have gas in it which will leak upon removing the bolt.

5. Remove the bolt, bolt seal, fuel cup, fuel cup seal and main jet from the body of the carburetor assembly. A carburetor screwdriver (not included) is needed to remove and install the Main Jet.

Note: The mixing tube is held in place by the main jet and might fall out when it is removed. If it falls out, replace it in the same orientation before replacing the main jet.

6. Replace the main jet with the replacement jet needed for your altitude range (part 1 or 2).

Note: The Fuel cup seal and bolt seal may be damaged during removal and should be replaced with the new ones from the kit.

7. Replace the Fuel Cup Seal (4), fuel cup, Bolt Seal (3) and bolt. Tighten in place.

CAUTION: Do not cross thread Bolt when tightening. Finger tighten first and then use a wrench to make sure the Bolt is properly threaded.

8. Wipe up any spilled fuel and allow excess to evaporate before starting engine. To prevent FIRE, do not start the engine while the smell of fuel hangs in the air.

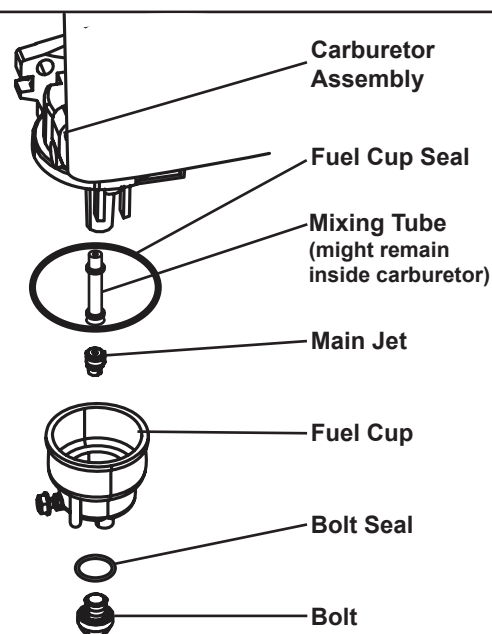

Altitude Kit Parts List

| Part | Description | Qty |
|------|------------------------|-----|
| 1 | Main Jet 3000-6000 ft. | 1 |
| 2 | Main Jet 6000-8000 ft. | 1 |
| 3 | Bolt Seal | 1 |
| 4 | Fuel Cup Seal | 1 |

PREDATOR[™]
E N G I N E S

Operation



Read the **ENTIRE IMPORTANT SAFETY INFORMATION** section at the beginning of this manual including all text under subheadings therein before set up or use of this product.

Pre-Start Checks

Inspect engine and equipment looking for damaged, loose, and missing parts before set up and starting. If any problems are found, do not use equipment until fixed properly.

Checking and Filling Engine Oil

NOTICE: Your Warranty is VOID if the engine's crankcase is not properly filled with oil before each use. Before each use, check the oil level. Do not run the engine with low or no engine oil. Running the engine with no or low engine oil WILL permanently damage the engine.

1. Make sure the engine is stopped and is level.
2. Close the Fuel Valve.
3. Clean the top of the Dipstick and the area around it. Remove the Dipstick by threading it counterclockwise, and wipe it off with a clean lint free rag.

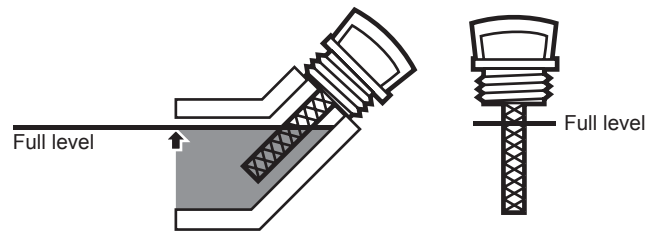

4. Reinsert the Dipstick without threading it in and remove it to check the oil level. The oil level should be up to the full level as shown above.
5. If the oil level is at or below the low mark add the appropriate type of oil until the oil level is at the proper level. SAE 10W-30 oil is recommended for general use. (The SAE Viscosity Grade chart on page 13 in the Service section shows other viscosities to use in different average temperatures.)
6. Thread the dipstick back in clockwise.

NOTICE: Do not run the engine with too little oil. The engine will be permanently damaged.

PREDATOR™

ENGINES

Checking and Filling Fuel



⚠ WARNING! TO PREVENT SERIOUS INJURY FROM FIRE:

Fill the fuel tank in a well-ventilated area away from ignition sources. If the engine is hot from use, shut the engine off and wait for it to cool before adding fuel.

Do not smoke.

1. Clean the Fuel Cap and the area around it.
2. Unscrew and remove the Fuel Cap.
3. If needed, fill the Fuel Tank to about 1 inch under the fill neck of the Fuel Tank with 87 octane or higher unleaded gasoline.

Note: Do not use gasoline containing more than 10% ethanol (E10). Do not use E85 ethanol.

Note: Do not use gasoline that has been stored in a metal fuel container or a dirty fuel container. It can cause particles to enter the carburetor, affecting engine performance and/or causing damage.

4. Then replace the Fuel Cap.
5. Wipe up any spilled fuel and allow excess to evaporate before starting engine. To prevent FIRE, do not start the engine while the smell of fuel hangs in the air.

Starting the Engine

Before Starting the Engine



Before starting the engine:

- a. Follow the Set Up Instructions in the equipment manual to prepare the equipment.
- b. Inspect the equipment and engine.
- c. Fill the engine with the proper amount and type of both fuel and oil.
- d. Read the Equipment Operation section in the equipment manual.

PREDATOR[™]
E N G I N E S

Manual Start

SAFETY

1. To start a cold engine, move the Choke to the CHOKE position.
To restart a warm engine, leave the Choke in the RUN position.

1

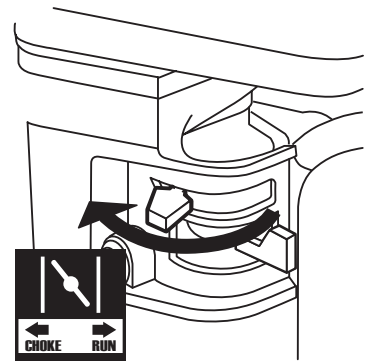

SETUP

2. Open the Fuel Valve.

2

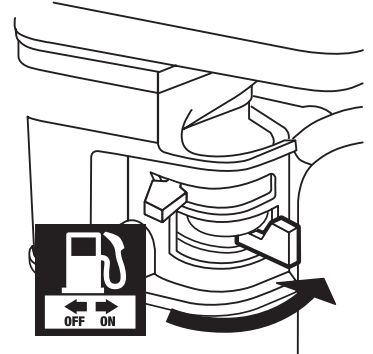

OPERATION

3. Slide the Throttle or Speed Control Lever to 1/3 away from the SLOW position (the "turtle").

Note: Some tools have a Speed Control Lever located elsewhere on the tool which functions the same as the Throttle. Use the Speed Control Lever in place of the Throttle when the tool is so equipped.

3



MAINTENANCE

4. Turn the Engine Switch on.

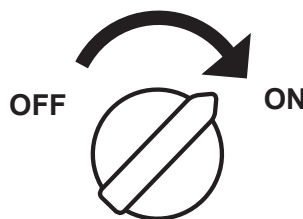

4

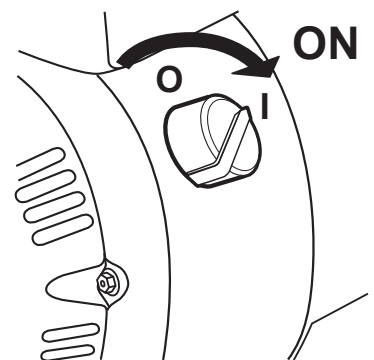

5. Grip the Starter Handle of the Engine loosely and pull it slowly several times to allow the gasoline to flow into the Engine's carburetor. Then pull the Starter Handle gently until resistance is felt. Allow Cable to retract fully and then pull it quickly. Repeat until the engine starts.

Note: Do not let the Starter Handle snap back against the engine. Hold it as it recoils so it doesn't hit the engine.

5

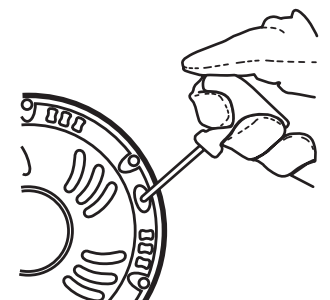

6. Allow the Engine to run for several seconds. Then, if the Choke lever is in the CHOKE position, move the Choke Lever very slowly to its RUN position.

Note: Moving the Choke Lever too fast could stall the engine.

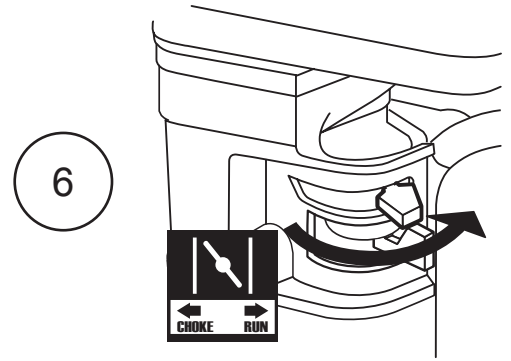

IMPORTANT: Allow the engine to run at no load for five minutes with no load after each start-up so that the engine can stabilize.

7. Adjust the Throttle as needed.
8. **Break-in Period:**
 - a. Breaking-in the engine will help to ensure proper equipment and engine operation.
 - b. The operational break-in period will last about 3 hours of use. During this period:
 - Do not apply a heavy load to the equipment.
 - Do not operate the engine at its maximum speed.
 - c. The maintenance break-in period will last about 20 hours of use. After this period:
 - Change the engine oil.

Under normal operating conditions subsequent maintenance follows the schedule explained in the MAINTENANCE AND SERVICING section.

Stopping the Engine

1. To stop the engine in an emergency, turn the Engine Switch off.
2. Under normal conditions, use the following procedure:
 - a. Slide the Throttle or Speed Control Lever to SLOW (the "turtle").
 - b. Turn the Engine Switch off.
 - c. Close the Fuel Valve.

WARNING! The fuel valve must be closed before moving the engine to prevent fuel leakage and fire.

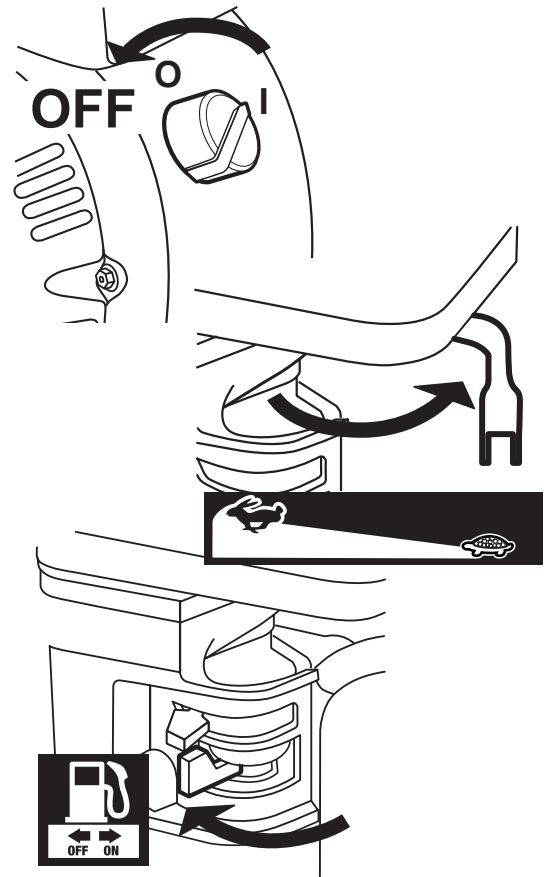

⚠ WARNING

TO PREVENT SERIOUS INJURY FROM ACCIDENTAL STARTING:

Turn the Power Switch of the equipment to its "OFF" position, wait for the engine to cool, and disconnect the spark plug cap before performing any inspection, maintenance, or cleaning procedures.

TO PREVENT SERIOUS INJURY FROM EQUIPMENT FAILURE:

Do not use damaged equipment. If abnormal noise, vibration, or excess smoking occurs, have the problem corrected before further use.

Follow all service instructions in this manual. The engine may fail critically if not serviced properly.



Many maintenance procedures, including any not detailed in this manual, will need to be performed by a qualified technician for safety. If you have any doubts about your ability to safely service the equipment or engine, have a qualified technician service the equipment instead.

Cleaning, Maintenance, and Lubrication Schedule

Note: This maintenance schedule is intended solely as a general guide. If performance decreases or if equipment operates unusually, check systems immediately. The maintenance needs of each piece of equipment will differ depending on factors such as duty cycle, temperature, air quality, fuel quality, and other factors.

Note: The following procedures are in addition to the regular checks and maintenance explained as part of the regular operation of the engine and equipment.

| Procedure | Before Each Use | Monthly or every 20 hr. of use | Every 3 mo. or 50 hr. of use | Every 6 mo. or 100 hr. of use | Yearly or every 300 hr. of use | Every 2 Years |
|--|-----------------|--------------------------------|------------------------------|-------------------------------|--------------------------------|---------------|
| Brush off outside of engine | ✓ | ✓ | ✓ | ✓ | ✓ | ✓ |
| Check engine oil level | ✓ | ✓ | ✓ | ✓ | ✓ | ✓ |
| Check air cleaner | ✓ | | ✓ | ✓ | ✓ | ✓ |
| Check deposit cup | ✓ | | | ✓ | ✓ | ✓ |
| Change engine oil | | ✓ | | ✓ | ✓ | ✓ |
| Clean/replace air cleaner | | | ✓* | ✓ | ✓ | ✓ |
| Check and clean spark plug | | | | ✓ | ✓ | ✓ |
| 1. Check/adjust idle speed 2. Check/adjust valve clearance 3. Clean fuel tank, strainer and carburetor 4. Clean carbon build-up from combustion chamber | | | | | ✓** | ✓** |
| Replace fuel line if necessary | | | | | | ✓** |

* Service more frequently when used in dusty areas.

** These items should be serviced by a qualified technician.



Checking and Filling Fuel



⚠ WARNING! TO PREVENT SERIOUS INJURY FROM FIRE:

Fill the fuel tank in a well-ventilated area away from ignition sources. If the engine is hot from use, shut the engine off and wait for it to cool before adding fuel.

Do not smoke.

1. Clean the Fuel Cap and the area around it.
2. Unscrew and remove the Fuel Cap.
3. If needed, fill the Fuel Tank to about 1 inch under the fill neck of the Fuel Tank with 87 octane or higher unleaded gasoline. Fill to the bottom of the fuel strainer ONLY, see below.

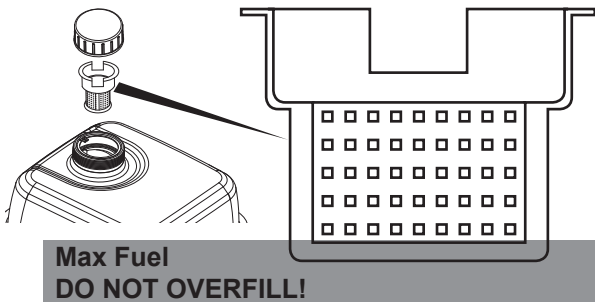

⚠ WARNING! TO PREVENT FUEL LEAKAGE AND FIRE HAZARD, do not fill fuel above the bottom of fuel strainer.

Note: Do not use gasoline containing more than 10% ethanol (E10). Do not use E85 ethanol.

Note: Do not use gasoline that has been stored in a metal fuel container or a dirty fuel container. It can cause particles to enter the carburetor, affecting engine performance and/or causing damage.

4. Then replace the Fuel Cap.
5. Wipe up any spilled fuel and allow excess to evaporate before starting engine. To prevent FIRE, do not start the engine while the smell of fuel hangs in the air.

Engine Oil Change

⚠ CAUTION! Oil is very hot during operation and can cause burns. Wait for engine to cool before changing oil.

1. Make sure the engine is stopped and is level.
2. Close the Fuel Valve.
3. Place a drain pan (not included) underneath the crankcase's drain plug.
4. Remove the drain plug and, if possible, tilt the crankcase slightly to help drain the oil out. Recycle used oil.
5. Replace the drain plug and tighten it.
6. Clean the top of the Dipstick and the area around it. Remove the Dipstick by threading it counterclockwise, and wipe it off with a clean lint free rag.

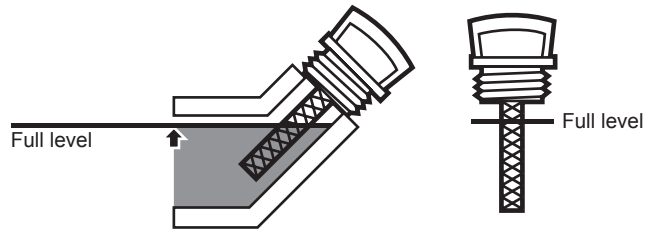

7. Add the appropriate type of oil until the oil level is at the full level. SAE 10W-30 oil is recommended for general use. The SAE Viscosity Grade chart shows other viscosities to use in different average temperatures.

SAE Viscosity Grades

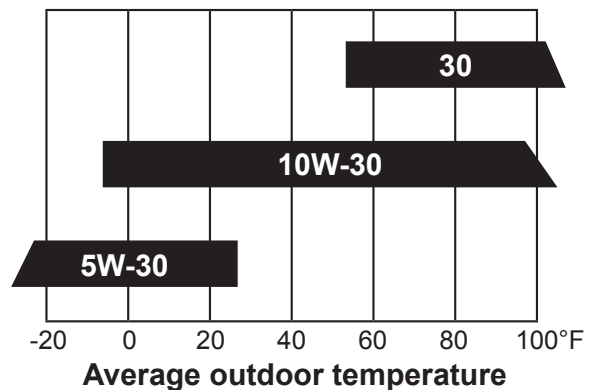

8. Thread the dipstick back in clockwise.

CAUTION! Do not run the engine with too little oil. The engine will be permanently damaged.

Air Filter Element Maintenance

1. Remove the air filter cover and the air filter elements and check for dirt. Clean or replace as described below.
2. **Cleaning:**
 - For “paper” filter elements:
To prevent injury from dust and debris, wear ANSI-approved safety goggles, NIOSH-approved dust mask/respirator, and heavy-duty work gloves. In a well-ventilated area away from bystanders, use pressurized air to blow dust out of the air filter. If this does not get the filter clean, replace it.
 - For foam filter elements:
Wash the element in warm water and mild detergent several times. Rinse. Squeeze out excess water and allow it to dry completely. Soak the filter in lightweight oil briefly, then squeeze out the excess oil.
3. Install the new filter or the cleaned filter. Secure the Air Cleaner Cover before use.

Spark Plug Maintenance

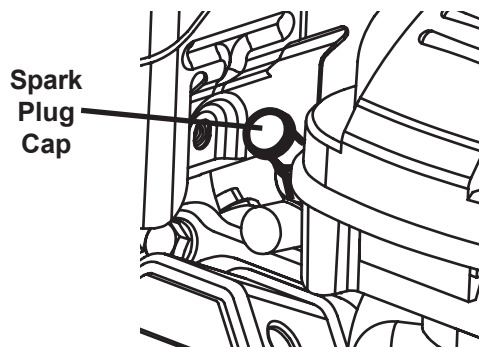

1. Disconnect spark plug cap from end of plug. Clean out debris from around spark plug.
2. Using a spark plug wrench, remove the spark plug.
3. Inspect the spark plug:
If the electrode is oily, clean it using a clean, dry rag. If the electrode has deposits on it, polish it using emery paper. If the white insulator is cracked or chipped, the spark plug needs to be replaced.

| Recommended Spark Plugs | |
|-------------------------|--------|
| NGK® | BP-6ES |
| NHSP®/ TORCH® | F6TC |

NOTICE: Using an incorrect spark plug may damage the engine.

4. When installing a new spark plug, adjust the plug's gap to the specification on the Technical Specifications chart. Do not pry against the electrode, the spark plug can be damaged.
5. Install the new spark plug or the cleaned spark plug into the engine. Gasket-style: Finger-tighten until the gasket contacts the cylinder head, then tighten about 1/2-2/3 turn more.
Non-gasket-style: Finger-tighten until the plug contacts the head, then tighten about 1/16 turn more.

NOTICE: Tighten the spark plug properly. If loose, the spark plug will cause the engine to overheat. If overtightened, the threads in the engine block will be damaged.

6. Apply dielectric spark plug boot protector (not included) to the end of the spark plug and reattach the wire securely.

Storage

When the equipment is to remain idle for longer than 20 days, prepare the engine for storage as follows:

1. CLEANING:

Wait for engine to cool, then clean engine with dry cloth. **NOTICE: Do not clean using water.** The water will gradually enter the engine and cause rust damage. Apply a thin coat of rust preventive oil to all metal parts.

2. FUEL:



⚠ WARNING! TO PREVENT SERIOUS INJURY FROM FIRE:

Drain the fuel tank in a well-ventilated area away from ignition sources. If the engine is hot from use, shut the engine off and wait for it to cool before draining fuel.

Do not smoke.

- Place a funnel leading to a proper gasoline container below the carburetor.

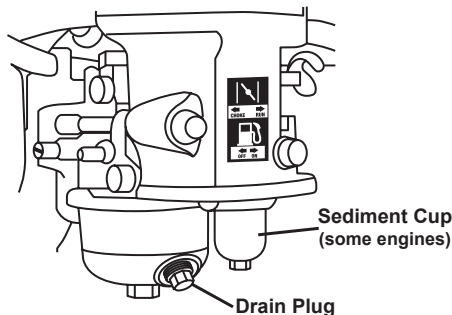

- Remove the drain bolt from the bottom of the carburetor bowl and allow the fuel to drain.
- Remove the small sediment cup next to the bowl and allow the fuel to drain from there as well.

- Open the fuel valve. After all fuel has drained, reinstall the drain bolt and sediment cup (if equipped). Tighten securely.

3. LUBRICATION:

- Change engine oil.
- Clean out area around spark plug. Remove spark plug and pour one tablespoon of engine oil into cylinder through spark plug hole.
- Replace spark plug, but leave spark plug cap disconnected.
- Pull Starter Handle to distribute oil in cylinder. Stop after one or two revolutions when you feel the piston start the compression stroke (when you start to feel resistance).

4. BATTERY:

Disconnect battery cables (if equipped). Recharge batteries monthly while in storage.

5. STORAGE AREA:

Cover and store in a dry, level, well-ventilated area out of reach of children. Storage area should also be away from ignition sources, such as water heaters, clothes dryers, and furnaces.

6. AFTER STORAGE:

Before starting the engine after storage, keep in mind that untreated gasoline will deteriorate quickly. Drain the fuel tank and change to fresh fuel if untreated gasoline has been sitting for a month, if treated gasoline has been sitting beyond the fuel stabilizer's recommended time period, or if the engine does not start.

PREDATOR™

ENGINES

Troubleshooting

| Problem | Possible Causes | Probable Solutions |
|-----------------------|--|--|
| Engine will not start | FUEL RELATED: <ol style="list-style-type: none"> No fuel in tank or fuel valve closed. Choke not in CHOKE position, cold engine. Gasoline with more than 10% ethanol used. (E15, E20, E85, etc.) Low quality or deteriorated, old gasoline. Carburetor not primed. Dirty fuel passageways. Carburetor needle stuck. Fuel can be smelled in the air. Too much fuel in chamber. This can be caused by the carburetor needle sticking. Clogged Fuel Filter. | FUEL RELATED: <ol style="list-style-type: none"> Fill fuel tank and open fuel valve. Move Choke to CHOKE position. Clean out ethanol rich gasoline from fuel system. Replace components damaged by ethanol. Use fresh 87+ octane unleaded gasoline only. Do not use gasoline with more than 10% ethanol (E15, E20, E85, etc.). Use fresh 87+ octane unleaded gasoline. Do not use gasoline with more than 10% ethanol (E15, E20, E85, etc.). Pull on Starter Handle to prime. Clean out passageways using fuel additive. Heavy deposits may require further cleaning. Gently tap side of carburetor float chamber with screwdriver handle. Turn Choke to RUN position. Remove spark plug and pull the start handle several times to air out the chamber. Reinstall spark plug and set Choke to CHOKE position. Replace Fuel Filter. |
| | IGNITION (SPARK) RELATED: <ol style="list-style-type: none"> Spark plug cap not connected securely. Spark plug electrode wet or dirty. Incorrect spark plug gap. Spark plug cap broken. Circuit breaker tripped (electric start models only). Incorrect spark timing or faulty ignition system. | IGNITION (SPARK) RELATED: <ol style="list-style-type: none"> Connect spark plug cap properly. Clean spark plug. Correct spark plug gap. Replace spark plug cap. Reset circuit breaker. Check wiring and starter motor if breaker continues to trip. Have qualified technician diagnose/repair ignition system. |
| | COMPRESSION RELATED: <ol style="list-style-type: none"> Cylinder not lubricated. Problem after long storage periods. Loose or broken spark plug. (Hissing noise will occur when trying to start.) Loose cylinder head or damaged head gasket. (Hissing noise will occur when trying to start.) Engine valves or tappets mis-adjusted or stuck. | COMPRESSION RELATED: <ol style="list-style-type: none"> Pour tablespoon of oil into spark plug hole. Crank engine a few times and try to start again. Tighten spark plug. If that does not work, replace spark plug. If problem persists, may have head gasket problem, see #3. Tighten head. If that does not remedy problem, replace head gasket. Have qualified technician diagnose/repair ignition system. |



Follow all safety precautions whenever diagnosing or servicing the equipment or engine.

| Problem | Possible Causes | Probable Solutions |
|------------------------------------|--|--|
| Engine misfires | <ol style="list-style-type: none"> 1. Spark plug cap loose. 2. Incorrect spark plug gap or damaged spark plug. 3. Defective spark plug cap. 4. Old or low quality gasoline. 5. Incorrect compression. | <ol style="list-style-type: none"> 1. Check wire connections. 2. Re-gap or replace spark plug. 3. Replace spark plug cap. 4. Use only fresh 87+ octane unleaded gasoline. Do not use gasoline with more than 10% ethanol (E15, E20, E85, etc.). 5. Diagnose and repair compression. (Use Engine will not start: COMPRESSION RELATED section.) |
| Engine stops suddenly | <ol style="list-style-type: none"> 1. Low oil shutdown. 2. Fuel tank empty or full of impure or low quality gasoline. 3. Defective fuel tank cap creating vacuum, preventing proper fuel flow. 4. Faulty magneto. 5. Disconnected or improperly connected spark plug cap. | <ol style="list-style-type: none"> 1. Fill engine oil to proper level. Check engine oil before EVERY use. 2. Fill fuel tank with fresh 87+ octane unleaded gasoline. Do not use gasoline with more than 10% ethanol (E15, E20, E85, etc.). 3. Test/replace fuel tank cap. 4. Have qualified technician service magneto. 5. Secure spark plug cap. |
| Engine stops when under heavy load | <ol style="list-style-type: none"> 1. Dirty air filter 2. Engine running cold. | <ol style="list-style-type: none"> 1. Clean or replace element. 2. Allow engine to warm up prior to operating equipment. |
| Engine knocks | <ol style="list-style-type: none"> 1. Old or low quality gasoline. 2. Engine overloaded. 3. Incorrect spark timing, deposit buildup, worn engine, or other mechanical problems. | <ol style="list-style-type: none"> 1. Fill fuel tank with fresh 87+ octane unleaded gasoline. Do not use gasoline with more than 10% ethanol (E15, E20, E85, etc.). 2. Do not exceed equipment's load rating. 3. Have qualified technician diagnose and service engine. |
| Engine backfires | <ol style="list-style-type: none"> 1. Impure or low quality gasoline. 2. Engine too cold. 3. Intake valve stuck or overheated engine. 4. Incorrect timing. | <ol style="list-style-type: none"> 1. Fill fuel tank with fresh 87+ octane unleaded gasoline. Do not use gasoline with more than 10% ethanol (E15, E20, E85, etc.). 2. Use cold weather fuel and oil additives to prevent backfiring. 3. Have qualified technician diagnose and service engine. 4. Check engine timing. |



Follow all safety precautions whenever diagnosing or servicing the equipment or engine.

Limited 90 Day Warranty

Harbor Freight Tools Co. makes every effort to assure that its products meet high quality and durability standards, and warrants to the original purchaser that this product is free from defects in materials and workmanship for the period of 90 days from the date of purchase. This warranty does not apply to damage due directly or indirectly, to misuse, abuse, negligence or accidents, repairs or alterations outside our facilities, criminal activity, improper installation, normal wear and tear, or to lack of maintenance. We shall in no event be liable for death, injuries to persons or property, or for incidental, contingent, special or consequential damages arising from the use of our product. Some states do not allow the exclusion or limitation of incidental or consequential damages, so the above limitation of exclusion may not apply to you. THIS WARRANTY IS EXPRESSLY IN LIEU OF ALL OTHER WARRANTIES, EXPRESS OR IMPLIED, INCLUDING THE WARRANTIES OF MERCHANTABILITY AND FITNESS.

To take advantage of this warranty, the product or part must be returned to us with transportation charges prepaid. Proof of purchase date and an explanation of the complaint must accompany the merchandise. If our inspection verifies the defect, we will either repair or replace the product at our election or we may elect to refund the purchase price if we cannot readily and quickly provide you with a replacement. We will return repaired products at our expense, but if we determine there is no defect, or that the defect resulted from causes not within the scope of our warranty, then you must bear the cost of returning the product.

This warranty gives you specific legal rights and you may also have other rights which vary from state to state.

Emission Control System Warranty

California and United States Emission Control Defects Warranty Statement (for Model 68727)

The California Air Resources Board (herein CARB), the United States Environmental Protection Agency (herein EPA), and Harbor Freight Tools (herein HFT) are pleased to explain the emission control system warranty on your 2014-2015 Small Off-Road Engine (herein engine). In California, the engine must be designed, built and equipped to meet the State's stringent anti-smog standards. Elsewhere within the United States, new off-road, spark-ignition engines certified for model year 2014-2015, must meet similar standards set forth by the EPA. HFT must warrant the emission control system on your engine for the periods of time described below, provided there has been no abuse, neglect or improper maintenance of your engine.

Your emission control system may include parts such as the carburetor or fuel-injection system, and the ignition system. Also included may be hoses, belts, connectors and other emission-related assemblies.

Where a warrantable condition exists, HFT will repair your engine at no cost to you including diagnosis, parts and labor.

United States Emission Control Defects Warranty Statement (for Model 68730)

The United States Environmental Protection Agency (herein EPA) and Harbor Freight Tools (herein HFT) are pleased to explain the emission control system warranty on your 2014-2015 Small Off-Road Engine (herein engine). Within the United States, new off-road, spark-ignition engines certified for model year 2014-2015 and later, must be designed, built and equipped to meet the stringent anti-smog standards set forth by the EPA. HFT must warrant the emission control system on your engine for the periods of time described below, provided there has been no abuse, neglect or improper maintenance of your engine.

Your emission control system may include parts such as the carburetor or fuel-injection system, and the ignition system. Also included may be hoses, belts, connectors and other emission-related assemblies.

Where a warrantable condition exists, HFT will repair your engine at no cost to you including diagnosis, parts and labor.

Manufacturer's Warranty Coverage

The 2014-2015 and later engines are warranted for two (2) years. If any emission-related part on your engine is defective, the part will be repaired or replaced by HFT.

Harbor Freight Tools Emission Control Defects Warranty Coverage

Engines are warranted for a period of two (2) years relative to emission control parts defects, subject to the provisions set forth below. If any emission related part on your engine is defective, the part will be repaired or replaced by HFT.

Owner's Warranty Responsibilities

- As the engine owner, you are responsible for the performance of the required maintenance listed in your Owner's Manual. HFT recommends that you retain all receipts covering maintenance on your engine, but HFT cannot deny warranty solely for the lack of receipts or for your failure to ensure the performance of all scheduled maintenance.
- As the engine owner, you should, however, be aware that HFT may deny you warranty coverage if your engine or a part has failed due to abuse, neglect, improper maintenance, or unapproved modifications.
- You are responsible for shipping your engine to a HFT warranty station as soon as a problem exists. Contact the HFT Customer Service department at the number below to make shipping arrangements. The warranty repairs should be completed in a reasonable amount of time, not to exceed 30 days.

If you have any questions regarding your warranty rights and responsibilities, you should contact the Harbor Freight Tools Customer Service Department at 1-800-520-0882.

Harbor Freight Tools Emission Control Defects Warranty Provisions

1. Length of Coverage

HFT warrants to a first retail purchaser and each subsequent purchaser that the engine is free from defects in materials and workmanship that cause the failure of warranted parts for a period of two (2) years after the date of delivery to the first retail purchaser.

2. No Charge Repair or Replacement

Repair or replacement of any warranted part will be performed at no charge to the owner if the work is performed through a warranty station authorized by HFT. For emissions warranty service, contact the HFT Customer Service Department at 1-800-520-0882.

3. Consequential Damages Coverage

Coverage under this warranty shall also extend to the failure of any engine components caused by the failure of any warranted part while it is still covered under this warranty.

4. Coverage Exclusions

Warranty claims shall be filed in accordance with the provisions of the HFT warranty policy explained in the box at the top of the previous page. HFT shall not be liable for any loss of use of the engine, for any alternative usage, for any damage to goods, loss of time, or inconvenience. Warranty coverage shall also be excluded for any part which fails, malfunctions, or is damaged due to failure to follow the maintenance and operating instructions set forth in the Owner's Manual including, but not limited to:

- a) Use of parts which are not authorized by HFT
- b) Improper installation, adjustment or repair of the engine or of any warranted part unless performed by an authorized warranty center
- c) Failure to follow recommendations on fuel use contained in the Owner's Manual
- d) Improper or inadequate maintenance of any warranted parts
- e) Repairs performed outside of the authorized warranty service dealers
- f) Alterations by changing, adding to or removing parts from the engine.

5. Service and Maintenance

Component parts which are not scheduled for replacement as required maintenance or are scheduled only for regular inspection to the effect of "repair or replace as necessary" are warranted for the warranty period. Any warranted part which is scheduled for replacement as required maintenance is warranted for the period of time up to the first scheduled replacement point for that part. Any replacement part, provided it is equivalent in durability and performance, may be used in performance of maintenance or repairs. The owner is responsible for commissioning a qualified technician/mechanic to perform all required maintenance, as outlined in the Inspection, Cleaning, and Maintenance section in this manual.

6. Warranted Parts

1) Fuel Metering System

- i) Carburetor and its internal parts.
- ii) Air/fuel ratio feedback and control system.
- iii) Cold start enrichment system.
- iv) Fuel Tank.

2) Air Induction System

- i) Controlled hot air intake system.
- ii) Intake manifold.
- iii) Air filter.

3) Ignition System

- i) Spark Plugs.
- ii) Magneto or electronic ignition system.
- iii) Spark advance/retard system.

4) Exhaust Gas Recirculation (EGR) System (if so equipped)

- i) EGR valve body, and carburetor spacer.
- ii) EGR rate feedback and control system.

5) Air Injection System

- i) Air pump or pulse valve.
- ii) Valves affecting distribution of flow.
- iii) Distribution manifold.

6) Catalyst or Thermal Reactor System (if so equipped)

- i) Catalytic converter.
- ii) Thermal reactor.
- iii) Exhaust manifold.

7) Particulate Controls

Traps, filters, precipitators, and any other device used to capture particulate emissions.

PLEASE READ THE FOLLOWING CAREFULLY

THE MANUFACTURER AND/OR DISTRIBUTOR HAS PROVIDED THE PARTS LIST AND ASSEMBLY DIAGRAM IN THIS MANUAL AS A REFERENCE TOOL ONLY. NEITHER THE MANUFACTURER OR DISTRIBUTOR MAKES ANY REPRESENTATION OR WARRANTY OF ANY KIND TO THE BUYER THAT HE OR SHE IS QUALIFIED TO MAKE ANY REPAIRS TO THE PRODUCT, OR THAT HE OR SHE IS QUALIFIED TO REPLACE ANY PARTS OF THE PRODUCT. IN FACT, THE MANUFACTURER AND/OR DISTRIBUTOR EXPRESSLY STATES THAT ALL REPAIRS AND PARTS REPLACEMENTS SHOULD BE UNDERTAKEN BY CERTIFIED AND LICENSED TECHNICIANS, AND NOT BY THE BUYER. THE BUYER ASSUMES ALL RISK AND LIABILITY ARISING OUT OF HIS OR HER REPAIRS TO THE ORIGINAL PRODUCT OR REPLACEMENT PARTS THERETO, OR ARISING OUT OF HIS OR HER INSTALLATION OF REPLACEMENT PARTS THERETO.

69727 Parts List

| Part | Description | Qty |
|------|-----------------------------------|-----|
| 1 | Gasket, Cylinder Head | 1 |
| 2 | Cover Subassembly, Cylinder Head | 1 |
| 3 | Gasket, Cylinder Head Cover | 1 |
| 4 | Tube, Breather | 1 |
| 5 | Bolt | 4 |
| 6 | Stud | 2 |
| 7 | Stud | 2 |
| 8 | Pin | 2 |
| 9 | Bolt, Cylinder Head | 4 |
| 10 | Plug, Spark | 1 |
| 11 | Head Subassembly, Cylinder | 1 |
| 12 | Crankcase Subassembly | 1 |
| 13 | Sensor, Engine Oil | 1 |
| 14 | Gear Asm, Governor | 1 |
| 15 | Arm, Governor | 1 |
| 16 | Bolt, Drain Plug | 2 |
| 17 | Washer, Flat | 2 |
| 18 | Bearing, Deep Groove Ball | 2 |
| 19 | Seal, Oil | 1 |
| 20 | Washer, Flat | 1 |
| 21 | Cotter | 1 |
| 22 | Bolt | 2 |
| 23 | Cover, Crankcase | 1 |
| 24 | Gasket, Crankcase | 1 |
| 25 | Pin | 2 |
| 26 | Dipstick Subassembly, Oil | 1 |
| 27 | Plug Subassembly, Engine Oil | 1 |
| 28 | Seal, Oil | 1 |
| 29 | Bolt | 6 |
| 30 | Crankshaft Asm. | 1 |
| 31 | Clip, Piston Pin | 2 |
| 32 | Piston | 1 |
| 33 | Pin, Piston | 1 |
| 34 | Rod, Connecting | 1 |
| 35 | Primary Ring | 1 |
| 36 | Secondary Ring | 1 |
| 37 | Ring Set, Oil | 1 |
| 38 | Camshaft Asm. | 1 |
| 39 | Valve, Exhaust | 1 |
| 40 | Valve, Intake | 1 |
| 41 | Seat, Valve Spring | 2 |
| 42 | Clamp, Valve Lock | 4 |
| 43 | Guide, Seal | 2 |
| 44 | Spring, Valve | 2 |
| 45 | Plate Subassembly, Lifter Stopper | 1 |
| 46 | Bolt, Rocker Shaft | 2 |
| 47 | Rocker, Valve | 2 |

| Part | Description | Qty |
|------|-----------------------------------|-----|
| 48 | Nut, Valve Adjusting | 2 |
| 49 | Nut, Valve Lock | 2 |
| 50 | Tappet, Valve | 2 |
| 51 | Lifter, Valve | 2 |
| 52 | Starter Asm, Recoil | 1 |
| 53 | Bolt | 1 |
| 54 | Shroud | 1 |
| 55 | Bolt | 4 |
| 56 | Shroud, Cylinder Body | 1 |
| 57 | Bolt | 2 |
| 58 | Shield, Lower | 1 |
| 59 | Bolt | 1 |
| 60 | Protector, Oil | 1 |
| 61 | Collar | 1 |
| 62 | Switch Subassembly, Stop Engine | 1 |
| 63 | Gasket, Carburetor Insulator | 1 |
| 64 | Plate, Carburetor Insulator | 1 |
| 65 | Gasket, Carburetor | 1 |
| 66 | Gasket, Air Cleaner | 1 |
| 67 | Nut | 2 |
| 68 | Cleaner, Air | 1 |
| 69 | Gasket, Exhaust Outlet | 1 |
| 70 | Nut | 2 |
| 71 | Muffler Asm. | 1 |
| 72 | Tank, Fuel | 1 |
| 73 | Strainer, Fuel | 1 |
| 74 | Cover, Fuel Tank | 1 |
| 75 | Outlet Subassembly, Fuel Tank Oil | 1 |
| 76 | Collar | 1 |
| 77 | Tube, Fuel | 1 |
| 78 | Jacket, Rubber | 1 |
| 79 | Nut | 2 |
| 80 | Nut, Flywheel | 1 |
| 81 | Pulley, Starter | 1 |
| 82 | Impeller | 1 |
| 83 | Flywheel Subassembly | 1 |
| 84 | Bolt | 2 |
| 85 | Coil, Ignition | 1 |
| 86 | Support Subassembly, Governor | 1 |
| 87 | Nut | 1 |
| 88 | Bolt, Governor Support | 1 |
| 89 | Spring, Governor | 1 |
| 90 | Rod, Governor | 1 |
| 91 | Spring, Throttle Valve Returning | 1 |
| 92 | Control Asm, Throttle | 1 |
| 93 | Bolt | 2 |

SAFETY

SETUP

OPERATION

MAINTENANCE

69727 Assembly Diagram

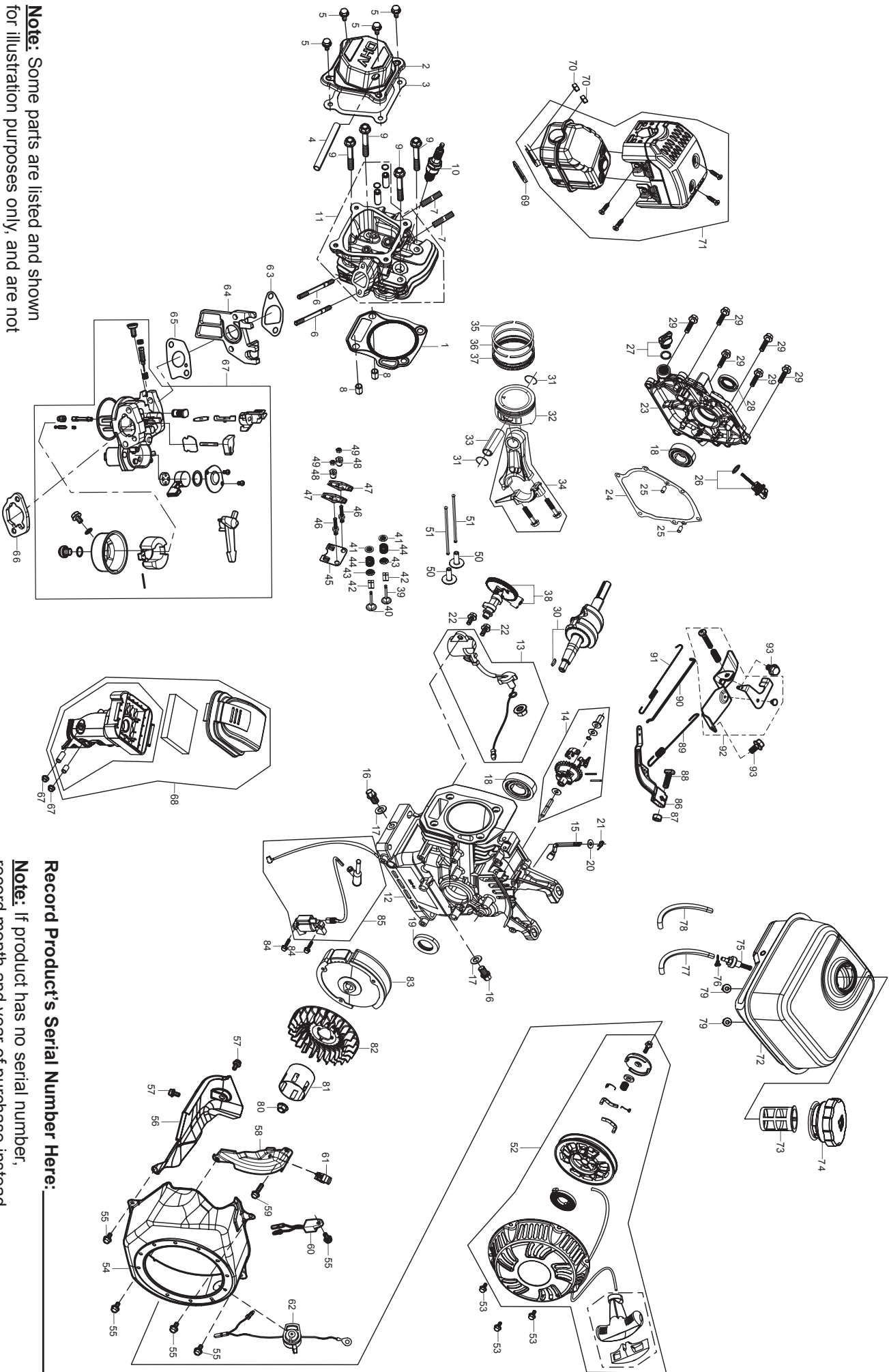

Note: Some parts are listed and shown for illustration purposes only, and are not available individually as replacement parts.

Record Product's Serial Number Here: _____

Note: If product has no serial number, record month and year of purchase instead.

69730 Parts List

SAFETY

SETUP

OPERATION

MAINTENANCE

| Part | Description | Qty |
|------|-----------------------------------|-----|
| 1 | Gasket, Cylinder Head | 1 |
| 2 | Cover Subassembly, Cylinder Head | 1 |
| 3 | Gasket, Cylinder Head Cover | 1 |
| 4 | Tube, Breather | 1 |
| 5 | Bolt | 4 |
| 6 | Stud | 1 |
| 7 | Stud | 1 |
| 8 | Stud | 2 |
| 9 | Pin | 2 |
| 10 | Bolt, Cylinder Head | 4 |
| 11 | Plug, Spark | 1 |
| 12 | Head Subassembly, Cylinder | 1 |
| 13 | Crankcase Subassembly | 1 |
| 14 | Sensor, Engine Oil | 1 |
| 15 | Gear Assy, Governor | 1 |
| 16 | Arm, Governor | 1 |
| 17 | Bolt, Drain Plug | 2 |
| 18 | Washer | 2 |
| 19 | Bearing | 1 |
| 20 | Seal, Oil | 1 |
| 21 | Washer | 1 |
| 22 | Pin | 1 |
| 23 | Bolt | 2 |
| 24 | Cover, Crankcase | 1 |
| 25 | Bearing | 1 |
| 26 | Seal, Oil | 1 |
| 27 | Gasket, Crankcase | 1 |
| 28 | Pin | 2 |
| 29 | Dipstick Subassembly, Oil | 1 |
| 30 | Plug Subassembly, Engine Oil | 1 |
| 31 | Bolt | 6 |
| 32 | Crankshaft Assy. | 1 |
| 33 | Clip, Piston Pin | 2 |
| 34 | Piston | 1 |
| 35 | Pin, Piston | 1 |
| 36 | Rod, Connecting | 1 |
| 37 | Ring, Primary | 1 |
| 38 | Ring, Secondary | 1 |
| 39 | Ring Set, Oil | 1 |
| 40 | Camshaft Assy. | 1 |
| 41 | Valve, Exhaust | 1 |
| 42 | Valve, Intake | 1 |
| 43 | Seat, Valve Spring | 1 |
| 44 | Retainer, Exhaust Valve | 1 |
| 45 | Rotator, Valve | 1 |
| 46 | Guide, Seal | 1 |
| 47 | Tappet, Valve | 2 |
| 48 | Lifter, Valve | 2 |
| 49 | Plate Subassembly, Lifter Stopper | 1 |
| 50 | Bolt, Valve Adjusting | 2 |
| 51 | Rocker, Valve | 2 |

| Part | Description | Qty |
|------|-----------------------------------|-----|
| 52 | Nut, Valve Adjusting | 2 |
| 53 | Nut, Valve Lock | 2 |
| 54 | Spring, Valve | 2 |
| 55 | Starter Assy, Recoil | 1 |
| 56 | Bolt | 3 |
| 57 | Shroud | 1 |
| 58 | Shroud, Cylinder Body | 1 |
| 59 | Shield, Lower | 1 |
| 60 | Protector, Oil | 1 |
| 61 | Switch Subassembly, Stop Engine | 1 |
| 62 | Bolt | 2 |
| 63 | Bolt | 1 |
| 64 | Collar | 1 |
| 65 | Bolt | 1 |
| 66 | Bolt | 4 |
| 67 | Carburetor Assy. | 1 |
| 68 | Gasket, Air Cleaner | 1 |
| 69 | Gasket, Carburetor | 1 |
| 70 | Plate, Carburetor Insulator | 1 |
| 71 | Gasket, Carburetor Insulator | 1 |
| 72 | Nut | 2 |
| 73 | Cleaner, Air | 1 |
| 74 | Jacket, Rubber | 1 |
| 75 | Gasket, Exhaust Outlet | 1 |
| 76 | Nut | 2 |
| 77 | Muffler Assy | 1 |
| 78 | Tank, Fuel | 1 |
| 79 | Strainer, Fuel | 1 |
| 80 | Cover, Fuel Tank | 1 |
| 81 | Outlet Subassembly, Fuel Tank Oil | 1 |
| 82 | Clamp | 3 |
| 83 | Tube, Fuel | 1 |
| 84 | Bolt | 1 |
| 85 | Nut | 2 |
| 86 | Nut, Flywheel | 1 |
| 87 | Pulley, Starter | 1 |
| 88 | Impeller | 1 |
| 89 | Flywheel Subassembly | 1 |
| 90 | Bolt | 2 |
| 91 | Coil, Ignition | 1 |
| 92 | Control Assy, Throttle | 1 |
| 93 | Bolt | 2 |
| 94 | Spring, Governor | 1 |
| 95 | Rod, Governor | 1 |
| 96 | Spring, Throttle Valve Returning | 1 |
| 97 | Bolt, Governor Support | 1 |
| 98 | Nut | 1 |
| 99 | Support Subassembly, Governor | 1 |
| 100 | Valve, One Way | 1 |
| 101 | Clamp | 1 |
| 102 | Hose, Fuel Steam Rubber | 1 |

69730 Assembly Diagram

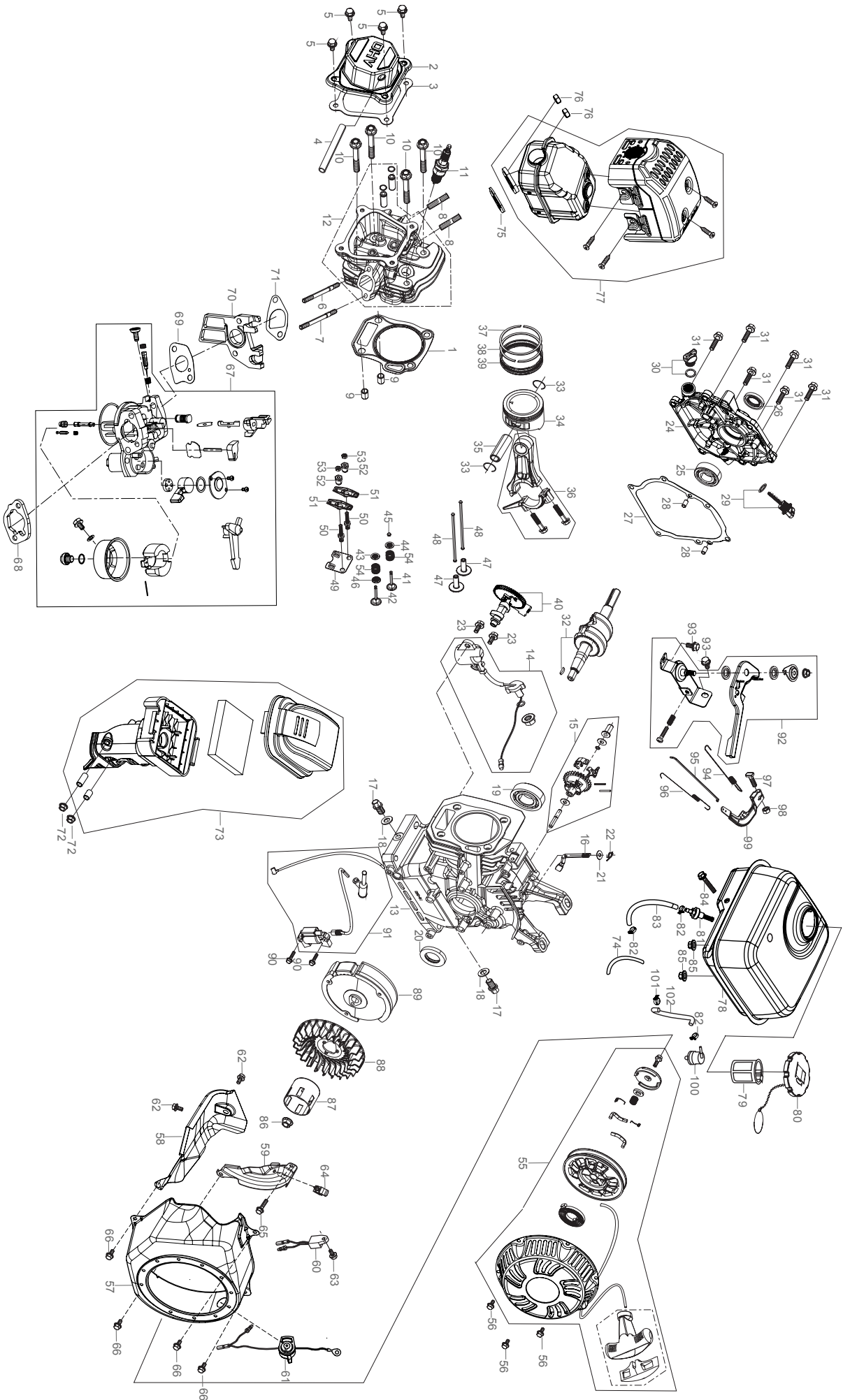

Mounting Hole Diagram

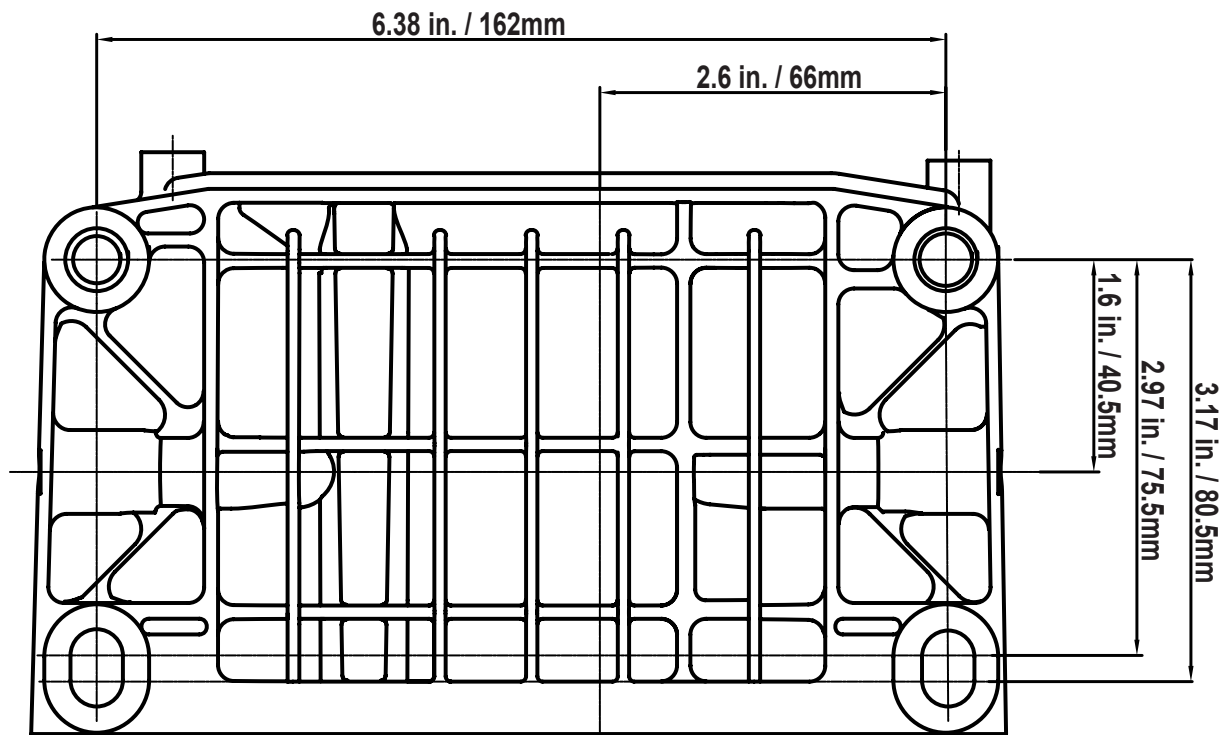

Power Take-Off Diagram

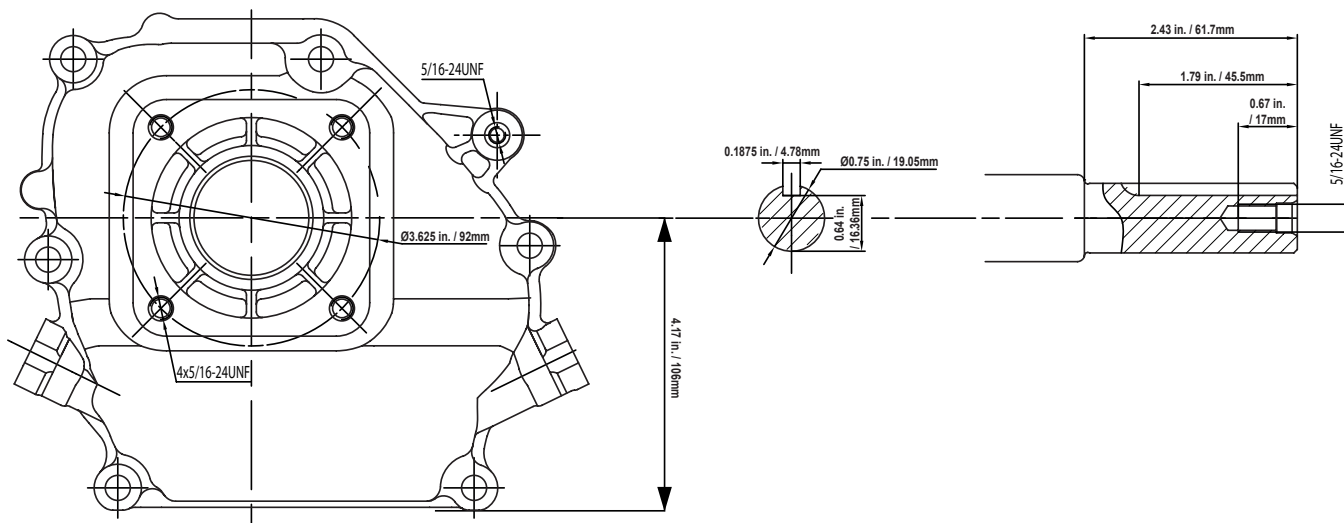

Note: Not to scale.

PREDATOR™

ENGINES

3491 Mission Oaks Blvd. • PO Box 6009 • Camarillo, CA 93011 • 1-800-520-0882

Free Manuals Download Website

<http://myh66.com>

<http://usermanuals.us>

<http://www.somanuals.com>

<http://www.4manuals.cc>

<http://www.manual-lib.com>

<http://www.404manual.com>

<http://www.luxmanual.com>

<http://aubethermostatmanual.com>

Golf course search by state

<http://golfingnear.com>

Email search by domain

<http://emailbydomain.com>

Auto manuals search

<http://auto.somanuals.com>

TV manuals search

<http://tv.somanuals.com>