

CENTRAL PNEUMATIC®

PANCAKE AIR COMPRESSOR

2 HP - 4 GALLON

Model 95499

ASSEMBLY AND OPERATION INSTRUCTIONS

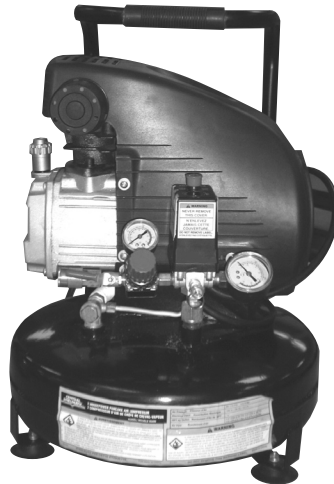

CAUTION!

Your Warranty Is Voided If:

- a. **You do not put compressor oil in the Compressor's crankcase prior to its first use.**
Before each use, check the oil level. Never run the Compressor with low or no compressor oil. Running the Compressor with low or no oil will permanently damage the unit.
- b. **You drop the Air Compressor.**
Always lift the Air Compressor using its Handle.

Visit our website at: <http://www.harborfreight.com>

**TO PREVENT SERIOUS INJURY, READ AND UNDERSTAND
ALL WARNINGS AND INSTRUCTIONS BEFORE USE.**

Copyright© 2007 by Harbor Freight Tools®. All rights reserved. No portion of this manual or any artwork contained herein may be reproduced in any shape or form without the express written consent of Harbor Freight Tools. Diagrams within this manual may not be drawn proportionally. Due to continuing improvements, actual product may differ slightly from the product described herein. Tools required for assembly and service may not be included.

For technical questions or replacement parts, please call 1-800-444-3353.

Revised Manual 09j

SPECIFICATIONS

| | |
|-------------------------|--|
| Electrical Requirements | 120 V~ / 60 Hz / 2 HP Motor / 3400 RPM 14 Rated Amps Power Cord Type: 14 AWG x 3 C x 6'10-1/2" Long Power Plug Type: 3 Prong Grounded Pressure Switch Type: ON/OFF (Pull/Push) |
| Compressor Style | Pancake Round Tank |
| Pump Style | Single Cylinder |
| Maximum Air Pressure | 115 PSI |
| Air Flow Capacity | 5.8 SCFM @ 40 PSI 4.4 SCFM @ 90 PSI |
| Auto Turn On/Shut Off | Pressure On @ 85 PSI / Pressure Off @ 115 PSI |
| Air Tank Capacity | 4 Gallons |
| Air Outlet Size | 1/4"-18 NPT Female Threads |
| Recommended Oil Type | SAE 15W-30W Non-Detergent Compressor Oil |
| Overall Dimensions | 15-3/4" Diameter x 21" High |
| Weight | 50 lb. |

SAVE THIS MANUAL

You will need this manual for the safety warnings and precautions, assembly, operating, inspection, maintenance and cleaning procedures, parts list and assembly diagram. Keep your invoice with this manual. Write the invoice number on the inside of the front cover. Keep this manual and invoice in a safe and dry place for future reference.

GENERAL SAFETY RULES AND PRECAUTIONS

 **WARNING!**

READ AND UNDERSTAND ALL INSTRUCTIONS
Failure to follow all instructions listed below may result in
electric shock, fire, and/or serious injury.
SAVE THESE INSTRUCTIONS

WORK AREA

1. **Keep your work area clean and well lit.** Cluttered benches and dark areas invite accidents.
2. **Do not operate air compressors in explosive atmospheres, such as in the presence of flammable liquids, gases, or dust.** Air Compressors create sparks which may ignite the dust or fumes.
3. **Keep bystanders, children, and visitors away while operating an air tool.** Distractions can cause you to lose control. Protect others in the work area from debris such as chips and sparks. Provide barriers or shields as needed. Children should not be allowed in the work area.

PERSONAL SAFETY

1. **Stay alert. Watch what you are doing, and use common sense when operating an air tool. Do not use an air tool while tired or under the influence of drugs, alcohol, or medication.** A moment of inattention while operating air tools may result in serious personal injury.
2. **Dress properly. Do not wear loose clothing or jewelry. Contain long hair. Keep your hair, clothing, and gloves away from moving parts.** Loose clothes, jewelry, or long hair can be caught in moving parts.
3. **Avoid accidental starting. Be sure the Pressure Switch (63) is in its “STOP” position, all pressure is safely released, and the unit is unplugged before moving the Compressor *and* before performing any service, maintenance, or cleaning procedures on the unit.**
4. **Remove adjusting keys or wrenches before turning the Compressor on.** A wrench or a key that is left attached to a rotating part of the machine may result in personal injury.
5. **Do not overreach. Keep proper footing and balance at all times.** Proper footing and balance enables better control of the air tool in unexpected situations.
6. **Use safety equipment. Always wear eye protection.** Always wear ANSI-approved safety impact glasses and hearing protection under a full face shield during use.

TOOL USE AND CARE

1. **Do not force the tool. Use the correct tool for your application.** The correct tool will do the job better and safer at the rate for which it is designed.
2. **Do not use the Compressor if the Compressor’s Pressure Switch (63) does not turn it on or off.** Any tool that cannot be controlled with its Pressure Switch is dangerous and must be replaced.
3. **Store idle tools out of reach of children and other untrained persons.** Tools are dangerous in the hands of untrained users.
4. **Maintain tools with care.** Properly maintained tools are less likely to bind and are easier to control. Do not use a damaged tool. Tag damaged tools “**Do not use**” until repaired.
5. **Check for misalignment or binding of moving parts, breakage of parts, and any other condition that may affect the tool’s operation. If damaged, have the tool serviced before using.** Many accidents are caused by poorly maintained tools.
6. **Use only accessories that are recommended by the manufacturer for your model.** Accessories that may be suitable for one tool may become hazardous when used on another tool.

SERVICE

1. **Tool service must be performed only by qualified repair personnel.** Service or maintenance performed by unqualified personnel could result in a risk of injury.
2. **When servicing a tool, use only identical replacement parts. Follow instructions in the “*Inspection, Maintenance, And Cleaning*” section of this manual.** Use of unauthorized parts or failure to follow maintenance instructions may create a risk of electric shock or injury.

SPECIFIC SAFETY RULES AND PRECAUTIONS

1. **CAUTION! Your Warranty is voided if:**
 - a. **You do not put compressor oil in the Compressor’s crankcase prior to its first use.** Before each use, check the oil level. Never run the Compressor with low or no compressor oil. Running the Compressor with low or no oil will permanently damage the unit.
 - b. **You drop the Air Compressor.** Always lift the Air Compressor using its Handle.
2. **DANGER! This Air Compressor is NOT equipped and should not be used “as-is” to supply breathing air.** For any application of air for human consumption, you must fit the Air Compressor with suitable in-line safety and alarm equipment (not included). This additional equipment is necessary to properly filter and purify the air to meet minimal specifications for Grade D breathing as described in Compressed Gas Association Commodity Specification G 7.1-1966, OSHA 29 CFR 1910. 134, and/or Canadian Standards Associations (CSA). In the event the Air Compressor is used for the purpose of breathing air application and proper in-line safety and alarm equipment is not simultaneously used, existing warranties are void, and Harbor Freight Tools disclaims any liability whatsoever for any loss, personal injury, or damage.
3. **DANGER!** Never attempt to repair or modify the Air Tank (50). Welding, drilling, or any other modification will weaken the Tank resulting in damage from rupture or explosion. Always replace worn, cracked, or damaged Tanks.
4. **Maintain labels and nameplates on the Air Compressor.** These carry important information. If unreadable or missing, contact Harbor Freight Tools for a replacement.
5. **WARNING!** Never use plastic (PVC) pipe for compressed air; serious injury or death could result. Any tube, pipe, or hose used must have a pressure rating higher than 150 PSI. Minimum recommended pipe size: Up to 50 feet long use 1/2” diameter. Greater than 50 feet use 3/4” diameter. Larger diameter pipe is always better.

6. **Make sure all tools and equipment used with the Air Compressor are rated to the appropriate capacity.** Do not use any tool or equipment that does not operate from 85 PSI to 115 PSI.
7. **Drain the Air Compressor every day.** Do not allow excessive moisture to build up inside the Air Compressor's Tank. Do not open the Drain Valve (54) with more than 10 PSI of air pressure in the Tank. Do not unscrew the Drain Valve so that *more than* four threads are showing.
8. **Avoid injury.** Never direct the Air Outlet Valve (67) at people or animals.
9. **Do not alter or remove the Safety Release Valve (61).**
10. **Make sure the Air Compressor is located on a flat, level, sturdy surface capable of supporting the weight of the Compressor, operator(s), and any additional tools and equipment.**
11. **Do not move or transport the Compressor if the Air Tank (50) is under pressure.**
12. **Industrial applications must follow OSHA guidelines.**
13. **Never stand on the Air Compressor.** Serious injury could result if the Compressor is tipped.
14. **Never leave the Air Compressor unattended when it is plugged in and running.** Turn off the Compressor, and unplug the unit before leaving.
15. **Do not allow children and other unauthorized people to handle or play with the Air Compressor.**
16. **Do not modify the factory set pressure shutoff or startup switches.** This tool will do the work better and safer at the speed and capacity for which it was designed.
17. **Avoid body contact with oils and lubricants used in the Compressor.** If swallowed, seek medical treatment immediately. For skin contact, immediately wash with soap and water. For eye contact, immediately flush eyes with clean water.
18. **WARNING: The brass components of this product contain lead, a chemical known to the State of California to cause birth defects (or other reproductive harm).** (California Health & Safety code § 25249.5, *et seq.*)
19. **People with pacemakers should consult their physician(s) before use.** Electromagnetic fields in close proximity to heart pacemaker could cause pacemaker interference or pacemaker failure.
20. **WARNING!** The warnings and precautions discussed in this manual cannot cover all possible conditions and situations that may occur. It must be understood by the operator that common sense and caution are factors which cannot be built into this product, but must be supplied by the operator.

07d

SAVE THESE INSTRUCTIONS

GROUNDING

WARNING!

Improperly connecting the grounding wire can result in the risk of electric shock. Check with a qualified electrician if you are in doubt as to whether the outlet is properly grounded. Do not modify the power cord plug provided with the tool. Never remove the grounding prong from the plug. Do not use the tool if the power cord or plug is damaged. If damaged, have it repaired by a service facility before use. If the plug will not fit the outlet, have a proper outlet installed by a qualified electrician.

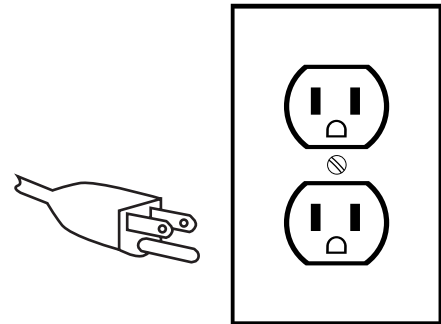

GROUNDING TOOLS: TOOLS WITH THREE PRONG PLUGS

1. Tools marked with “Grounding Required” have a three wire cord and three prong grounding plug. The plug must be connected to a properly grounded outlet. If the tool should electrically malfunction or break down, grounding provides a low resistance path to carry electricity away from the user, reducing the risk of electric shock. **(See 3-Prong Plug and Outlet.)**
2. The grounding prong in the plug is connected through the green wire inside the cord to the grounding system in the tool. The green wire in the cord must be the only wire connected to the tool’s grounding system and must never be attached to an electrically “live” terminal. **(See 3-Prong Plug and Outlet.)**
3. Your tool must be plugged into an appropriate outlet, properly installed and grounded in accordance with all codes and ordinances. The plug and outlet should look like those in the following illustration. **(See 3-Prong Plug and Outlet.)**



3-Prong Plug and Outlet

SYMBOLOLOGY

| | |
|---|--------------------------------------|
|  | Double Insulated |
|  | Canadian Standards Association |
|  | Underwriters Laboratories, Inc. |
| V~ | Volts Alternating Current |
| A | Amperes |
| n ₀ xxxx/min. | No Load Revolutions per Minute (RPM) |

UNPACKING

When unpacking, check to make sure all the parts shown on the **Parts List on page 13** are included. If any parts are missing or broken, please call Harbor Freight Tools at the number shown on the cover of this manual as soon as possible.

ASSEMBLY INSTRUCTIONS

1. **CAUTION!** Always make sure the Compressor's Pressure Switch (63) is in its "STOP" position prior to performing any service, maintenance, or cleaning of the Compressor.

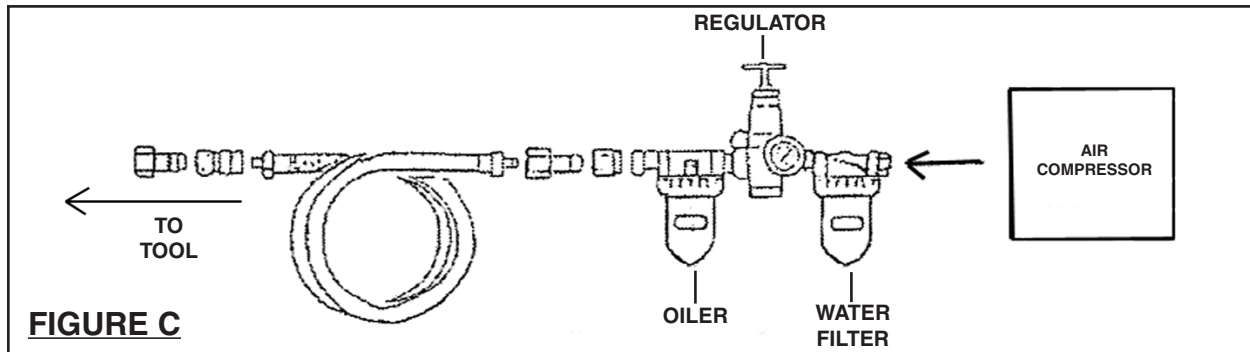

2. **To extend the life of your tools and equipment,** it is recommended that you install an oiler and water filter in-line with the Air Outlet Valve (67) of the Air Compressor. (See Figure C.)
3. Prior to using the Air Compressor, the unit requires the attachment of a **1/4"-18 NPT Female Quick Connector** (not included). To do so, wrap approximately 3" of pipe thread sealant tape (not included) around the male threads of the Air Outlet Valve (67). Then firmly screw the Quick Connector into the Air Outlet Valve (67). (See Figure D.)

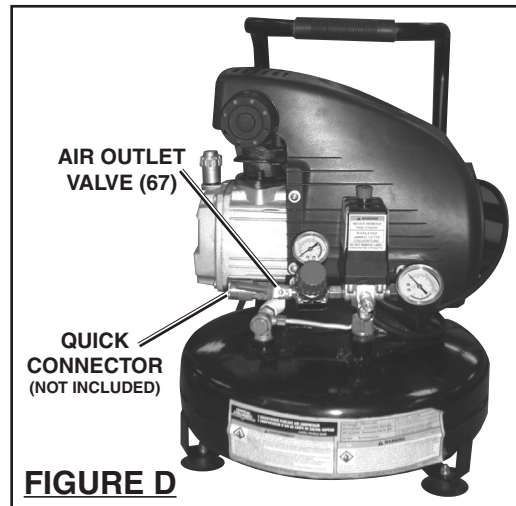

PRE-START INSTRUCTIONS – Adding Compressor Oil

1. **IMPORTANT!** Prior to first using the Compressor, the Compressor **MUST** be filled with a high quality **S.A.E. 15W-30W** grade non-detergent compressor oil.

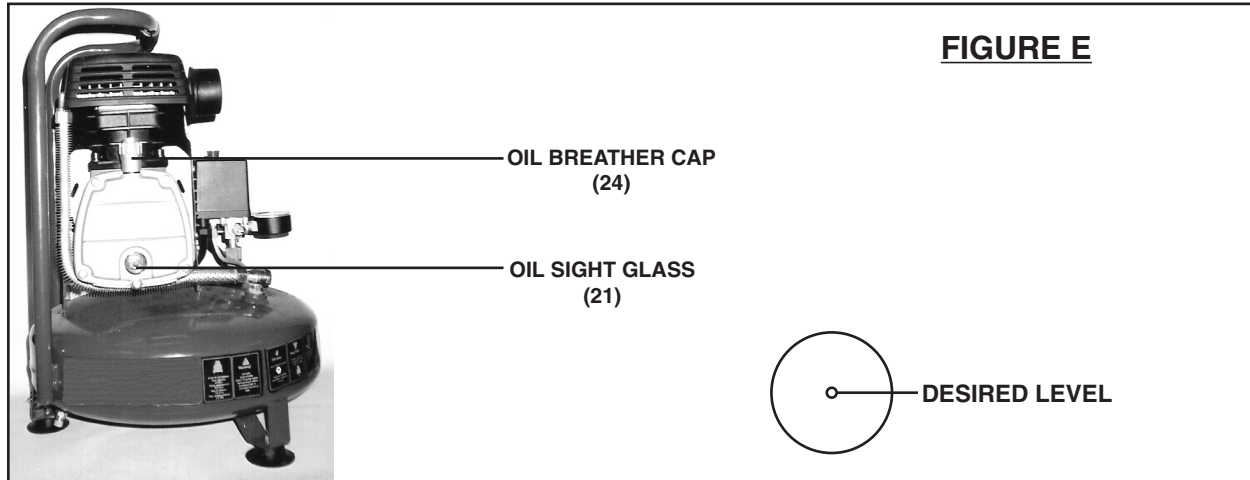

2. To do so, *unscrew* and remove the Oil Breather Cap (24). Pour approximately 1/2 quart of compressor oil into the Oil Breather Cap hole. **Do not overfill.** (See Figure E.)
3. Observe the level of compressor oil through the Oil Sight Glass (21). The optimal oil level is at the center of the glass.
4. When finished adding compressor oil, re-install the Oil Breather Cap (24) back into the Oil Breather Cap hole. (See Figure E.)

OPERATING INSTRUCTIONS

To Start The Compressor:

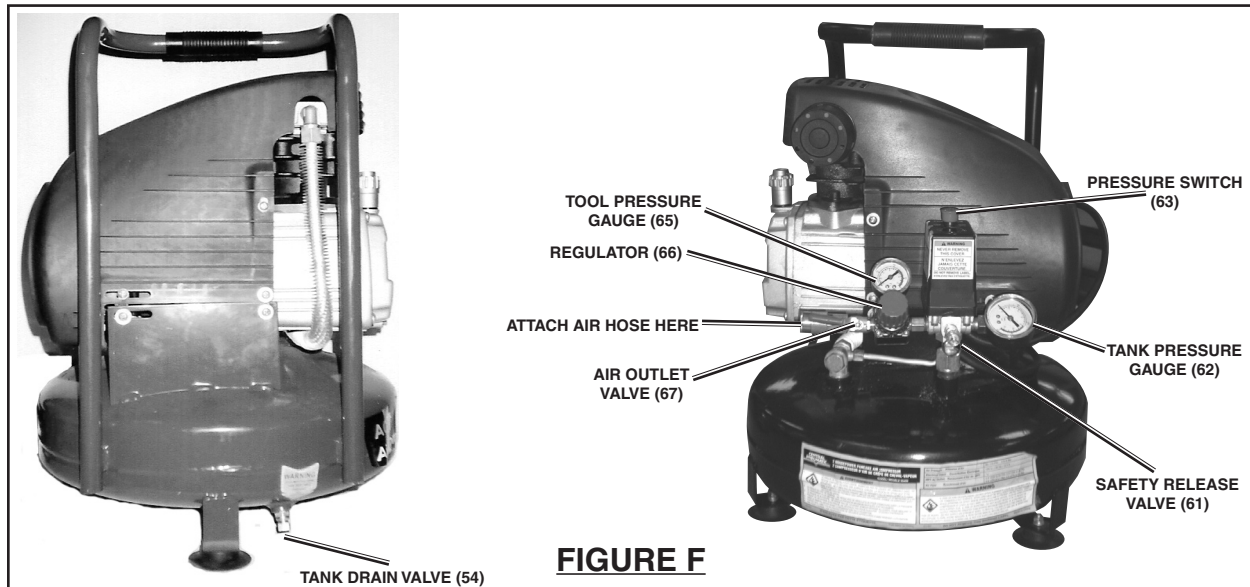

1. Check to make sure the Air Tank's Drain Valve (54), located at the bottom of the Air Tank (50), is fully closed. Pull on the Safety release valve to verify that it is unstuck. **(See Figure F.)**
2. Turn the Air Outlet Valve (67) to its **closed** position. **(See Figure F.)**
3. Connect an air hose (not included) to the previously installed Quick Connector. Then, connect the other end of the air hose to the pneumatic tool (not included) that is to be used. **(See Figure F, next page.)**
4. Plug the Power Cord (55) into the nearest 120 volt, grounded, electrical outlet.
5. Pull **up** on the Pressure Switch (63) to its “**START**” position to turn on the unit. **(See Figure F.)**
6. When the Tank Pressure Gauge (62) reaches at least **85 PSI**, turn the Air Outlet Valve to its **open** position to allow air to the pneumatic tool. **(See Figure F.)**
7. Once the air pressure reaches the pneumatic tool, observe the Tool Pressure Gauge (65). Adjust the Regulator (66) to feed the proper PSI to the tool. To do so, turn the Regulator *clockwise* to increase the PSI. Turn the Regulator *counterclockwise* to decrease the PSI. **(See Figure F.)**
8. **NOTE:** When the maximum air pressure, **115 PSI**, is reached as indicated by the Tank Pressure Gauge (62), the motor will stop. The Compressor will automatically restart when the air pressure drops below **85 PSI**. **(See Figure F.)**

To Stop The Compressor:

1. Push down on the Pressure Switch (63) to its “**STOP**” position. **(See Figure F.)**
2. Unplug the Air Compressor from its electrical outlet.
3. Squeeze the trigger on the pneumatic tool to release any remaining air pressure from the tool. Then disconnect the air hose from the tool, and store the tool in a clean, dry, safe location out of reach of children. Turn the Air Outlet Valve (67) to its **closed** position.
4. Disconnect the other end of the air hose from the Compressor’s Air Outlet Valve (67), and store the air hose in a clean, dry, safe location out of reach of children.
5. Pull out on the Safety Release Valve (61) to release all remaining air pressure from the Air Tank (50). **(See Figure F.)**
6. Remove any moisture in the Air Tank (50) by opening the Tank Drain Valve (54). Then, retighten the Drain Valve. **(See Figure F.)**
7. Allow the Air Compressor to completely cool. Then store the unit in a clean, dry, safe location out of reach of children.

INSPECTION, MAINTENANCE, AND CLEANING

1. **WARNING!** Make sure the Pressure Switch (63) of the Air Compressor is in its “**STOP**” position and the unit is unplugged from its electrical outlet before performing any inspection, maintenance, or cleaning procedures or leaving it unattended.
2. **Before each use**, inspect the general condition of the Air Compressor. Check for loose screws, misalignment or binding of moving parts, cracked or broken parts, damaged electrical wiring, loose air fittings, and any other condition that may affect the safe operation of the Compressor. If abnormal noise or vibration occurs, have the problem corrected before further use.
Do not use damaged equipment.
3. **Before each use**, check the compressor oil level in the Oil Sight Glass (21). If necessary, fill the crankcase of the Air Compressor with the proper amount and type of compressor oil.
4. **Daily**, purge the Air Tank (50) of all air and moisture to prevent corrosion. To do so, slowly and carefully unscrew (no more than four threads) the Tank Drain Valve (54) until the compressed air and condensation begins to be released from the Tanks. Allow sufficient time for all of the air and condensation to escape from the Tanks. Then, firmly re-tighten the Drain Valve.
5. **CAUTION! All maintenance, service, or repairs not mentioned in this manual must only be performed by a qualified service technician.**

TROUBLESHOOTING

| Problem | Possible Cause | Possible Solution |
|---|---|--|
| Compressor will not start. | <ol style="list-style-type: none"> 1. Blown fuse or circuit breaker tripped. 2. Loose electrical connections. 3. Bad Capacitors. | <ol style="list-style-type: none"> 1. Replace or reset fuse/circuit breaker. 2. Make sure Compressor is plugged into a working, 120 volt, grounded, electrical outlet. 3. Replace capacitors. |
| Low pressure. | <ol style="list-style-type: none"> 1. Restricted air filter. 2. Defective check valve. 3. Air leak in safety valve. 4. Defective Valve Plate. | <ol style="list-style-type: none"> 1. Replace air filter. 2. Have a qualified service technician replace check valve. 3. Check valve by pulling on ring. If condition persists, have a qualified service technician replace valve. 4. Replace Valve Plate. |
| Safety valve releasing. | <ol style="list-style-type: none"> 1. Defective pressure switch. 2. Defective Safety Valve. | <ol style="list-style-type: none"> 1. Have a qualified service technician replace pressure switch. 2. Replace Safety Valve. |
| Oil discharge in air. | <ol style="list-style-type: none"> 1. Too much oil in crankcase. 2. Compressor overheated. 3. Restricted oil breather cap. | <ol style="list-style-type: none"> 1. Drain crankcase and refill to proper level on sight glass. 2. Reduce air pressure regulation. 3. Clean or replace oil breather cap. |
| Pressure switch will not turn off Compressor. | Defective pressure switch. | Immediately unplug Compressor from its electrical outlet. Do not operate Compressor until a qualified service technician can replace pressure switch. |

PLEASE READ THE FOLLOWING CAREFULLY

THE MANUFACTURER AND/OR DISTRIBUTOR HAS PROVIDED THE PARTS LIST AND ASSEMBLY DIAGRAM IN THIS MANUAL AS A REFERENCE TOOL ONLY. NEITHER THE MANUFACTURER OR DISTRIBUTOR MAKES ANY REPRESENTATION OR WARRANTY OF ANY KIND TO THE BUYER THAT HE OR SHE IS QUALIFIED TO REPLACE ANY PARTS OF THE PRODUCT. IN FACT, THE MANUFACTURER AND/OR DISTRIBUTOR EXPRESSLY STATES THAT ALL REPAIRS AND PARTS REPLACEMENTS SHOULD BE UNDERTAKEN BY CERTIFIED AND LICENSED TECHNICIANS, AND NOT BY THE BUYER. THE BUYER ASSUMES ALL RISKS AND LIABILITY ARISING OUT OF HIS OR HER REPAIRS TO THE ORIGINAL PRODUCT OR REPLACEMENT PARTS THERETO, OR ARISING OUT OF HIS OR HER INSTALLATION OF REPLACEMENT PARTS THERETO.

PARTS LIST AND ASSEMBLY DIAGRAM

| Part | Description |
|------|-----------------------------|
| 1 | Plastic Cowling |
| 2 | Spring Washer |
| 3 | Washer (#5) |
| 4 | Pan Head Screw (M5 x 14) |
| 5 | Turbo Fan |
| 6 | Screw (M5 x 15) |
| 7 | Motor Rear Cover |
| 8 | Wave Washer |
| 9 | Bearing (6202) |
| 10 | Stator Assy. |
| 11 | Rotor Assy. |
| 12 | Capacitor 150uf/250V |
| 13 | Bearing (6204) |
| 14 | Oil Seal |
| 15 | Nut (M8) |
| 16 | Crankcase |
| 17 | Crank |
| 18 | Screw (M8 x 16 – Left Hand) |
| 19 | Crankcase Gasket |
| 20 | Crankcase Cover |
| 21 | Oil Sight Glass |
| 22 | Hex Head Screw |
| 23 | Pan Head Screw (M6 x 14) |

| Part | Description |
|------|--------------------------|
| 24 | Oil Breather Cap |
| 25 | Spring Washer (#8) |
| 26 | Washer (#8) |
| 27 | Screw (M8 x 20) |
| 28 | Connecting Rod |
| 29 | Piston |
| 30 | Circlip (#12) |
| 31 | Piston Pin |
| 32 | Cylinder Gasket |
| 33 | Cylinder |
| 34 | Spring Washer (#6) |
| 35 | Washer (#6) |
| 36 | Screw (M6 x 40) |
| 37 | Oil Clean Ring |
| 38 | Seal Ring |
| 39 | Valve Plate Gasket |
| 40 | Valve Plate Assy. |
| 41 | Air Intake Valve |
| 42 | Limit Pin |
| 43 | Cylinder Head Gasket |
| 44 | Air Filter Element Assy. |
| 45 | Cylinder Head |
| 46 | Square Elbow Connector |

| Part | Description |
|------|-------------------------|
| 47 | Exhaust Pipe Assy. |
| 48 | Non-Return Valve Assy. |
| 49 | Unload Pipe Assy. |
| 50 | Tank |
| 51 | Nut (M6) |
| 52 | Rubber Foot |
| 53 | Screw (M6 x 20) |
| 54 | Tank Drain Valve |
| 55 | Power Cord |
| 56 | Rear Motor Cover Gasket |
| 57 | Seal Washer |
| 58 | Connector Seat |
| 59 | Connector |
| 60 | Wheel Sleeve |
| 61 | Safety Release Valve |
| 62 | Tank Pressure Gauge |
| 63 | Pressure Switch |
| 64 | Connector |
| 65 | Tool Pressure Gauge |
| 66 | Regulator |
| 67 | Air Outlet Valve |

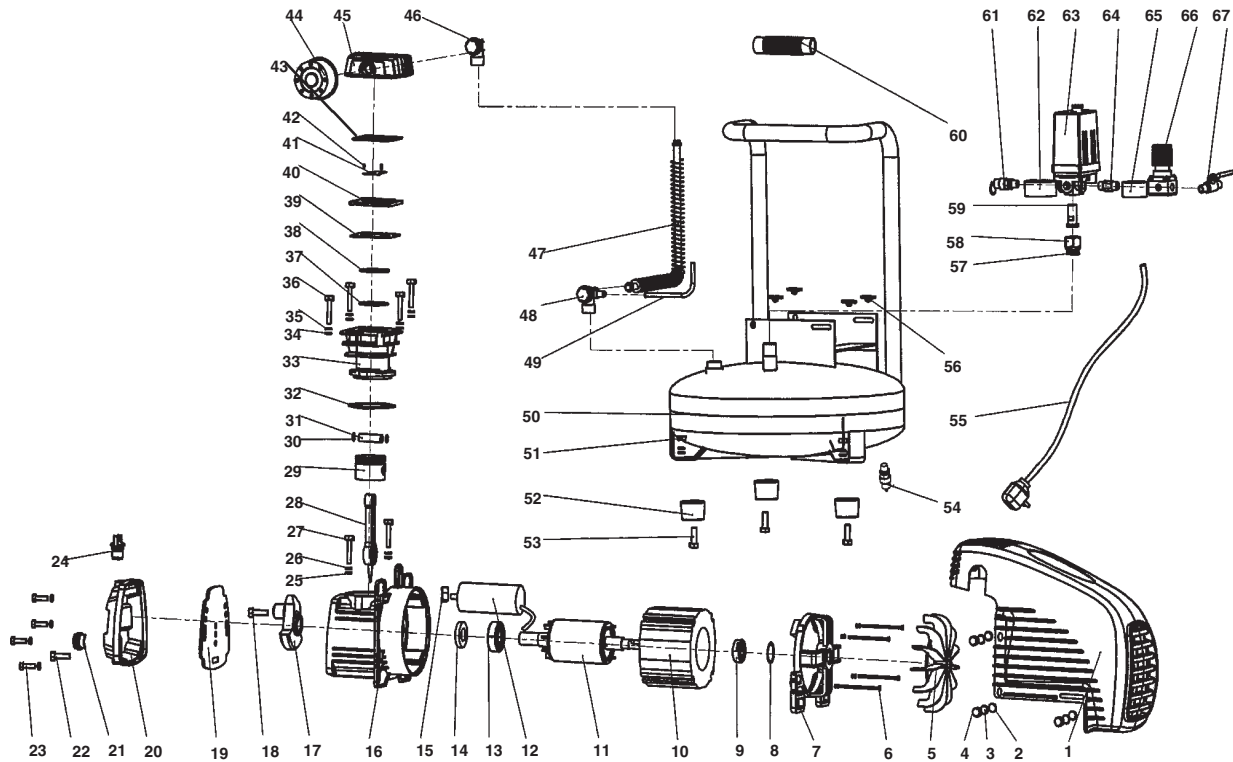

Note: Some parts are listed and shown for illustration purposes only, and are not available individually as replacement parts.

LIMITED 1 YEAR / 90 DAY WARRANTY

Harbor Freight Tools Co. makes every effort to assure that its products meet high quality and durability standards, and warrants to the original purchaser that for a period of one year from date of purchase that the tank is free of defects in materials and workmanship (90 days if used by a professional contractor or if used as rental equipment). Harbor Freight Tools also warrants to the original purchaser, for a period of ninety days from date of purchase, that all other parts and components of the product are free from defects in materials and workmanship. This warranty does not apply to damage due directly or indirectly to misuse, abuse, negligence or accidents, repairs or alterations outside our facilities, normal wear and tear, or to lack of maintenance. We shall in no event be liable for death, injuries to persons or property, or for incidental, contingent, special or consequential damages arising from the use of our product. Some states do not allow the exclusion or limitation of incidental or consequential damages, so the above limitation of exclusion may not apply to you. THIS WARRANTY IS EXPRESSLY IN LIEU OF ALL OTHER WARRANTIES, EXPRESS OR IMPLIED, INCLUDING THE WARRANTIES OF MERCHANTABILITY AND FITNESS.

To take advantage of this warranty, the product or part must be returned to us with transportation charges prepaid. Proof of purchase date and an explanation of the complaint must accompany the merchandise. If our inspection verifies the defect, we will either repair or replace the product at our election or we may elect to refund the purchase price if we cannot readily and quickly provide you with a replacement. We will return repaired products at our expense, but if we determine there is no defect, or that the defect resulted from causes not within the scope of our warranty, then you must bear the cost of returning the product.

This warranty gives you specific legal rights and you may also have other rights which vary from state to state.

3491 Mission Oaks Blvd. • PO Box 6009 • Camarillo, CA 93011 • (800) 444-3353

Free Manuals Download Website

<http://myh66.com>

<http://usermanuals.us>

<http://www.somanuals.com>

<http://www.4manuals.cc>

<http://www.manual-lib.com>

<http://www.404manual.com>

<http://www.luxmanual.com>

<http://aubethermostatmanual.com>

Golf course search by state

<http://golfingnear.com>

Email search by domain

<http://emailbydomain.com>

Auto manuals search

<http://auto.somanuals.com>

TV manuals search

<http://tv.somanuals.com>