

CENTRAL PNEUMATIC®

OILLESS AIR COMPRESSOR 8 GALLON CAPACITY

Model 94355

ASSEMBLY AND OPERATING INSTRUCTIONS

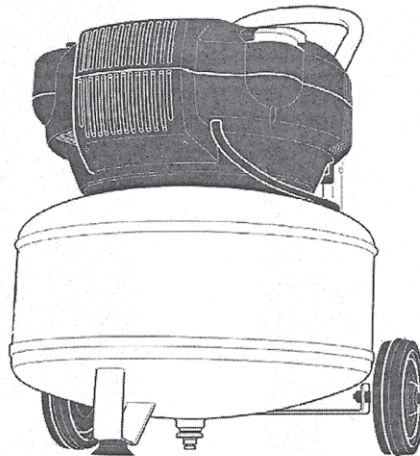

Due to continuing improvements,
actual product may differ slightly
from the product described herein.



**TO PREVENT SERIOUS INJURY,
READ AND UNDERSTAND ALL WARNINGS
AND INSTRUCTIONS BEFORE USE.**

3491 Mission Oaks Blvd., Camarillo, CA 93011
Visit our Web site at: <http://www.harborfreight.com>

Copyright® 2006 by Harbor Freight Tools®. All rights reserved. No portion of this manual or any artwork contained herein may be reproduced in any shape or form without the express written consent of Harbor Freight Tools.

For technical questions, please call 1-800-444-3353.

PRODUCT SPECIFICATIONS

Electrical Requirements	120 V / 60 Hz / 13 Amp / 2 HP Rated, 3 HP Peak Power Cord Type: 16 Gauge x 3 C x 6' Long Power Plug Type: 3-Prong, Grounded Fuse Size: 15 AMP Buss Fuse Switch Type: Rotary On/Off Switch
Operating Air Pressure	Pressure On: 85 PSI / Pressure Off: 125 PSI
Air Flow	6.0 CFM @ 40 PSI / 4 CFM @ 90 PSI
Air Tank Capacity	8 Gallons
Outlet Thread	1/4" - 18 NPT
Pressure Gauge Measures	0 ~ 230 PSI in 20 PSI Increments / 0 ~ 16 KG/CM ² in 2 BAR Increments
Additional Features	Thermal Overload Protection / Steel Tube Handle Rubber Wheels / Brass Valve Tank Drain / Single Cylinder Pump
Unit Weight	51 Pounds



SAVE THIS MANUAL

You will need this manual for the safety warnings and precautions, assembly, operating, inspection, maintenance and cleaning procedures, parts list and assembly diagram. Keep your invoice with this manual. Write the invoice number on the inside of the front cover. Keep this manual and invoice in a safe and dry place for future reference.

GENERAL SAFETY RULES AND PRECAUTIONS

WARNING!

READ AND UNDERSTAND ALL INSTRUCTIONS
Failure to follow all instructions listed below may result in
electric shock, fire, and/or serious injury.
SAVE THESE INSTRUCTIONS

SAFE OPERATION

- 1. RISK OF FIRE OR EXPLOSION:**
Do not spray flammable liquid in a confined area or towards a hot surface.
Spray area must be well ventilated.
Do not smoke while spraying or spray where spark or flame is present.

2. **ARCING PARTS:**
Keep compressor at least 20 feet away from explosive vapors, such as when spraying with a spray gun.
3. **IF CONNECTED TO A CIRCUIT PROTECTED BY FUSES:**
Use time delay (Marked D) fuses with this item.
Connect to a dedicated power sources (see serial plate for proper voltage).
Check oil level in the compressor before each use and fill accordingly.
4. **RISK OF BURSTING:**
Do not adjust the regulator to result in output pressure greater than marked maximum pressure of attachment (air tools, etc).
5. **RISK OF INJURY:**
Do not direct air stream at anyone's body.
Do not use compressed air for breathing.
Unplug the power cord and drain all air pressure from the tank before servicing and after each use.
Always wear ANSI-approved eye protection.
Do not operate with supplied guards removed or damaged.
6. **RISK OF ELECTRIC SHOCK:**
Do not expose to rain, store this item indoors in a dry location.

WORK AREA

1. **Keep your work area clean and well lit.** Cluttered benches and dark areas invite accidents.
2.  **Do not operate power tools in explosive atmospheres, such as in the presence of flammable liquids, gases, or dust.** Power tools create sparks which may ignite the dust or fumes.
3. **Keep bystanders, children, and visitors away while operating a power tool.** Distractions can cause you to lose control. Protect others in the work area from debris such as chips and sparks. Provide barriers or shields as needed.

PERSONAL SAFETY

1. **Stay alert. Watch what you are doing, and use common sense when operating a power tool. Do not use a power tool while tired or under the influence of drugs, alcohol, or medication.** A moment of inattention while operating power tools may result in serious personal injury.
2. **Dress properly. Do not wear loose clothing or jewelry. Contain long hair. Keep your hair, clothing, and gloves away from moving parts.** Loose clothes, jewelry, or long hair can be caught in moving parts.
3. **Avoid accidental starting. Be sure the Pressure Switch (57) is in its “OFF” position before moving the Compressor *and* before performing any service, maintenance, or cleaning procedures on the unit.**
4. **Remove adjusting keys or wrenches before turning the Compressor on.** A wrench or a key that is left attached to a rotating part of the machine may result in personal injury.
5. **Do not overreach. Keep proper footing and balance at all times.** Proper footing and balance enables better control of the power tool in unexpected situations.
6.  **Use safety equipment. Always wear eye protection.** Always wear ANSI-approved safety impact goggles when using this product. ANSI-approved hearing protection must also be used.

TOOL USE AND CARE

1. **Do not force the tool. Use the correct tool for your application.** The correct tool will do the job better and safer at the rate for which it is designed.
2. **Do not use the Compressor if the Pressure Switch (57) does not turn it on or off.** Any tool that cannot be controlled with its pressure switch is dangerous and must be replaced.
3. **Store idle tools out of reach of children and other untrained persons.** Tools are dangerous in the hands of untrained users.
4. **Maintain tools with care.** Properly maintained tools with a sharp cutting edge are less likely to bind and are easier to control. Do not use a damaged tool. Tag damaged tools “Do not use” until repaired.



5. **Check for misalignment or binding of moving parts, breakage of parts, and any other condition that may affect the tool's operation. If damaged, have the tool serviced before using.** Many accidents are caused by poorly maintained tools.
6. **Use only accessories that are recommended by the manufacturer for your model.** Accessories that may be suitable for one tool may become hazardous when used on another tool.

SERVICE

1. **Tool service must be performed only by qualified repair personnel.** Service or maintenance performed by unqualified personnel could result in a risk of injury.
2. **When servicing a tool, use only identical replacement parts. Follow instructions in the “*Inspection, Maintenance, And Cleaning*” section of this manual.** Use of unauthorized parts or failure to follow maintenance instructions may create a risk of electric shock or injury.

SPECIFIC SAFETY RULES AND PRECAUTIONS

1. **Maintain labels and nameplates on the Air Compressor.** These carry important information. If unreadable or missing, contact Harbor Freight Tools for a replacement.
2.  **DANGER!** This Air Compressor is NOT equipped with and should not be used “as is” to supply breathing quality air. For any application of air for human consumption, you must fit the Air Compressor with suitable inline safety and alarm equipment (not included). This additional equipment is necessary to properly filter and purify the air to meet minimal specifications for Grade D breathing as described in Compressed Gas Association Commodity Specification G 7.1-1966, OSHA 29 CFR 1910. 134, and/or Canadian Standards Associations (CSA). In the event the Air Compressor is used for the purpose of breathing air application and proper inline safety and alarm equipment is not simultaneously used, existing warranties are void, and Harbor Freight Tools disclaims any liability whatsoever for any loss, personal injury, or damage.
3. **Make sure all tools and equipment used with the Air Compressor are rated to the appropriate capacity.** Do not use any tool or equipment that does not operate from 85 PSI to 125 PSI.
4. **Drain the Air Compressor every day.** Do not allow excessive moisture to build up inside the Air Compressor. Do not open the water Drain Valve (4) with more than 10 PSI of air pressure in the Compressor.

5. **Avoid injury.** Never direct compressed air at people or animals.
6. **Make sure the Air Compressor is located on a flat, level, sturdy surface capable of supporting the weight of the Compressor and any additional tools and equipment.**
7. **Industrial applications must follow OSHA guidelines.**
8. **Never stand on the Air Compressor.** Serious injury could result if the Compressor is tipped.
9. **Never leave the Air Compressor unattended when it is plugged in and running.** Turn off the Compressor, and unplug the unit before leaving.
10. **Do not allow children and other unauthorized people to handle or play with the Air Compressor.**
11. **Do not move or transport the Compressor if the unit is under pressure.**
12. **Do not force the Compressor.** This tool will do the work better and safer at the speed and capacity for which it was designed.
13. **This Compressor will automatically shut off on overload or under excessive heat.** Should this occur, turn the Pressure Switch (57) to its "OFF" position. Wait until the Compressor cools. Then, turn the Pressure Switch to its "ON" position to resume work.
14.  **WARNING!** This product contains brass, which is a chemical known to the State of California to cause cancer and birth defects and other reproductive harm. (*California Health & Safety Code 25249.5, et seq.*)
15.  **WARNING!** People with pacemakers should consult their physician(s) before using this product. Operation of electrical equipment in close proximity to a heart pacemaker could cause interference to or failure of the pacemaker.
16.  **WARNING!** The warnings and precautions discussed in this manual cannot cover all possible conditions and situations that may occur. It must be understood by the operator that common sense and caution are factors which cannot be built into this product, but must be supplied by the operator.

SAVE THESE INSTRUCTIONS

GROUNDING

WARNING!

Improperly connecting the grounding wire can result in the risk of electric shock. Check with a qualified electrician if you are in doubt as to whether the outlet is properly grounded. Do not modify the power cord plug provided with the tool. Never remove the grounding prong from the plug. Do not use the tool if the power cord or plug is damaged. If damaged, have it repaired by a service facility before use. If the plug will not fit the outlet, have a proper outlet installed by a qualified electrician.

GROUNDING TOOLS: TOOLS WITH THREE PRONG PLUGS

1. Tools marked with “Grounding Required” have a three wire cord and three prong grounding plug. The plug must be connected to a properly grounded outlet. If the tool should electrically malfunction or break down, grounding provides a low resistance path to carry electricity away from the user, reducing the risk of electric shock. **(See Figure A.)**
2. The grounding prong in the plug is connected through the green wire inside the cord to the grounding system in the tool. The green wire in the cord must be the only wire connected to the tool’s grounding system and must never be attached to an electrically “live” terminal. **(See Figure A.)**
3. Your tool must be plugged into an appropriate outlet, properly installed and grounded in accordance with all codes and ordinances. The plug and outlet should look like those in the following illustration. **(See Figure A.)**

THIS PRODUCT
USES A
3-PRONG PLUG

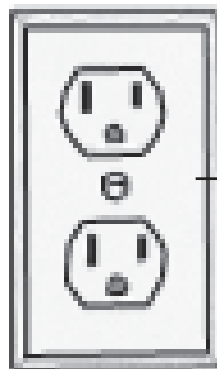

120VOLT, GROUNDED,
ELECTRICAL OUTLET

FIGURE A

DOUBLE INSULATED TOOLS: TOOLS WITH TWO PRONG PLUGS

- 4. Tools marked “Double Insulated” do not require grounding. They have a special double insulation system which satisfies OSHA requirements and complies with the applicable standards of Underwriters Laboratories, Inc., the Canadian Standard Association, and the National Electrical Code. **(See Figure B.)**
- 5. Double insulated tools may be used in either of the 120 volt outlets shown in the following illustration. **(See Figure B.)**

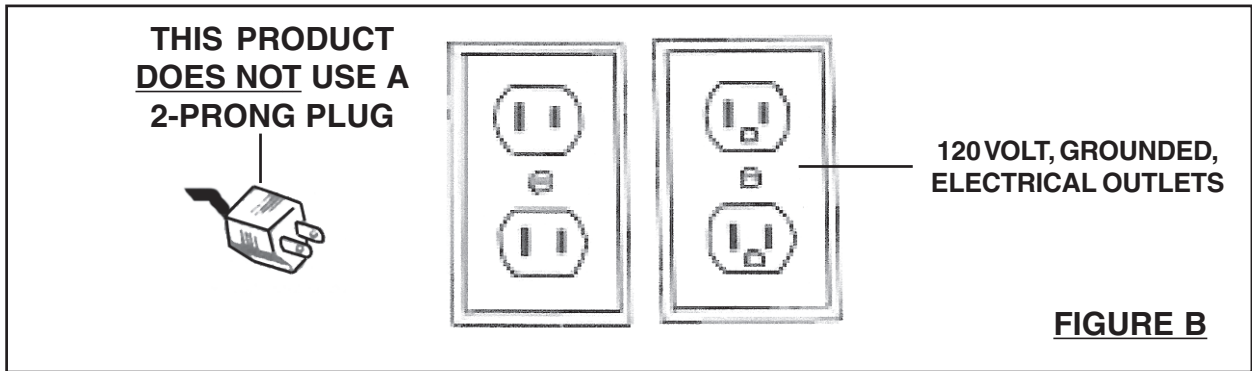

SYMBOLOLOGY

	Double Insulated
	Canadian Standards Association
	Underwriters Laboratories, Inc.
	Volts Alternating Current
	Amperes
	No Load Revolutions per Minute (RPM)

FIGURE C

UNPACKING

When unpacking, check to make sure all the parts shown on the **Parts List on page 14** are included. If any parts are missing or broken, please call Harbor Freight Tools at the number shown on the cover of this manual as soon as possible.

ASSEMBLY INSTRUCTIONS

1.  **CAUTION!** Always make sure the Pressure Switch (57) of the Air Compressor is in its “OFF” position and the unit is unplugged from its electrical outlet prior to performing any assembly on this unit.
2. To attach the Handle (9) to the Air Compressor, align the four mounting holes in the Handle with the four *threaded* mounting holes located at the rear of the unit. Then secure the Handle in place with four Screws (7). **(See Page 16)**
3. Slide the Quick Coupler (11) towards the compressor body and insert the Air Hose (71) to the Quick Coupler (11). **(See Page 16)**

AIR COMPRESSOR CONTROLS

1. **Pressure Switch (57):** The Pressure Switch turns the Air Compressor on and off. When in the “ON” position, the Pressure Switch allows the Compressor to automatically adjust to its “run” stage when the air pressure inside the Air Tank (3) falls below 85 PSI. The Pressure Switch also automatically turns the Compressor to its “idle” stage when the air pressure inside the Air Tank reaches 125 PSI. Always keep the Pressure Switch in its “OFF” position when the unit is not in use. **(See Figure D, next page.)**
2. **Safety Valve (10):** If the Pressure Switch (57) does not shut down the Motor of the Air Compressor when the pressure reaches 125 PSI, the Safety Valve will automatically pop open to prevent over-pressurization. To operate manually, pull the ring on the Safety Valve to relieve air pressure in the Air Tank (3). **(See Figure D, next page.)**
3. **Tank Pressure Gauge (13):** The Tank Pressure Gauge measures the pressure level of the air stored in the Air Tank (3), and is not adjustable by the operator. **(See Figure D.)**

4. **Pressure Regulator Knob (14):** The Pressure Regulator Knob enables the operator to adjust output pressure to the pneumatic tool being used. To increase the amount of air pressure to the tool, turn the Pressure Regulator Knob clockwise. To decrease the amount of air pressure to the tool, turn the Pressure Regulator Knob counterclockwise. **(See Figure D.)**
5. **Tool Pressure Gauge (13):** The Tool Pressure Gauge measures the pressure level of air flowing to the pneumatic tool being used, and is adjustable using the Pressure Regulator Knob (14). **(See Figure D.)**
6. **Quick Coupler (11):** The Quick Coupler connects to the air output hose which, in turn, connects to the pneumatic tool being used. To connect an air hose, push in on the Quick Coupler. To disconnect the air hose, pull back on the Quick Coupler collar. **(See Figure D.)**

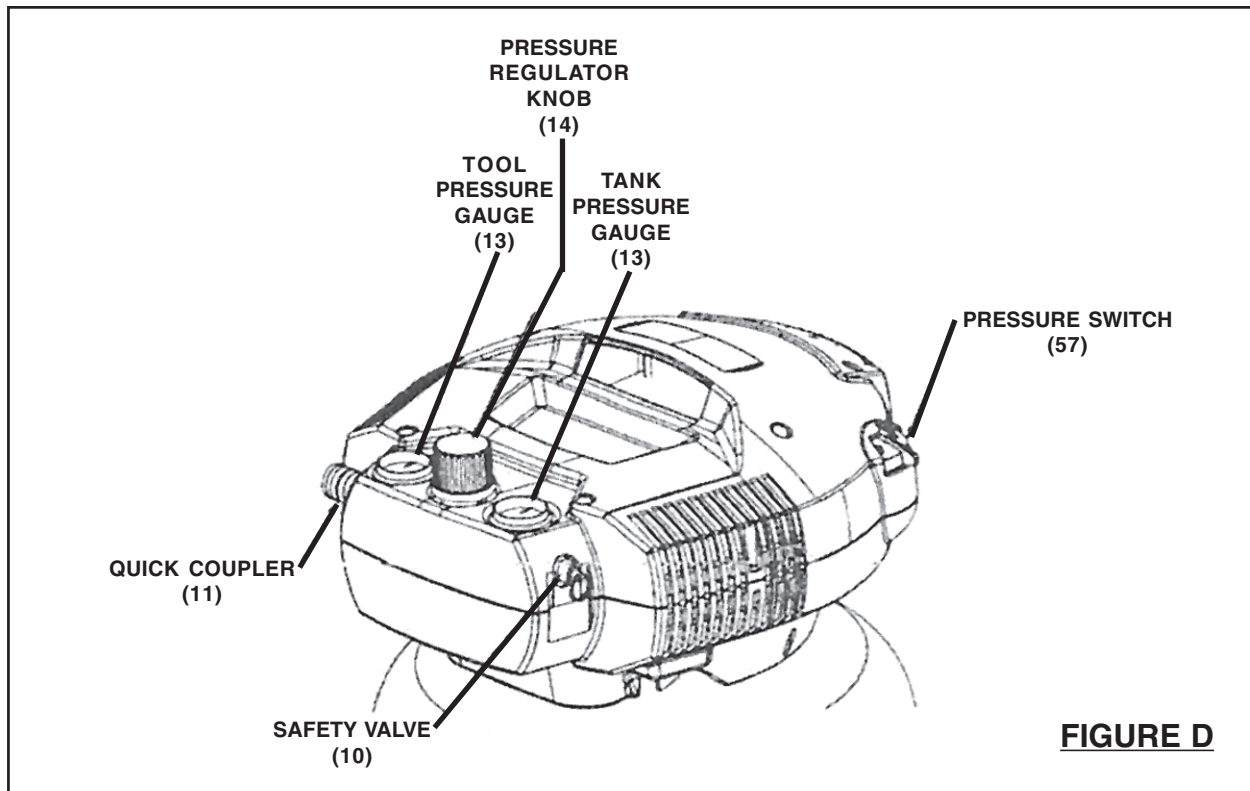

FIGURE D

OPERATING INSTRUCTIONS

1. **⚠ CAUTION!** Always make sure the Pressure Switch (57) of the Air Compressor is in its “OFF” position and the unit is unplugged from its electrical outlet prior to performing any service, maintenance, or changing accessories on the Compressor.

2. Before operating, make sure the Air Compressor is set up in a well ventilated area, on a flat, level, solid surface well away from any flammable objects.

To Start The Compressor:

1. Check to make sure the Air Compressor's water Drain Valve (4) is fully closed. (See Figure E.)

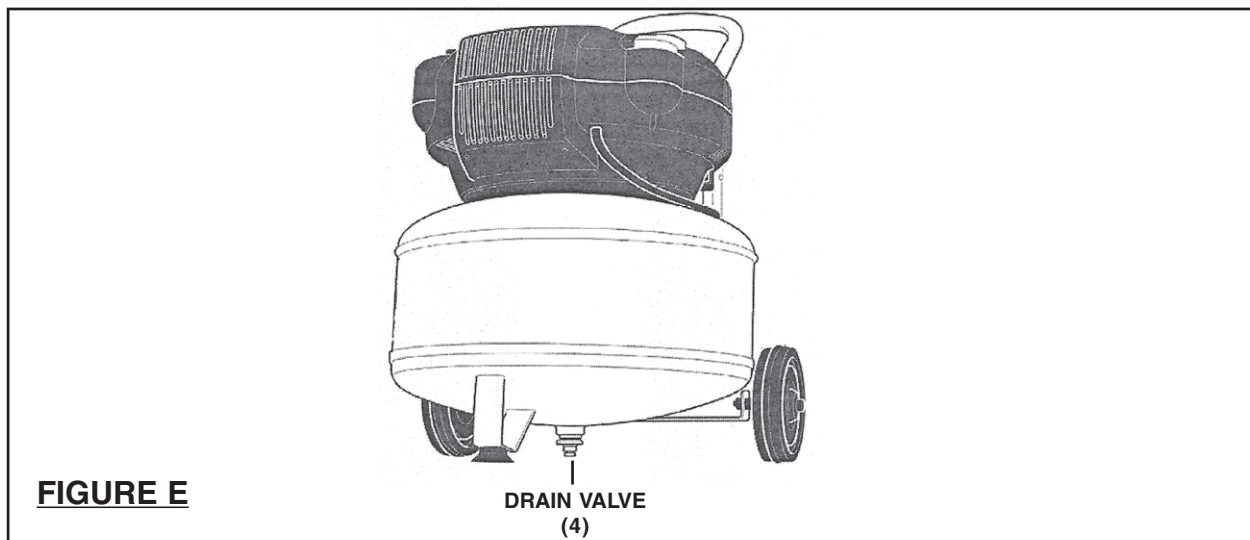

2. Connect one end of the air supply hose (not included) to the pneumatic tool being used. Then connect the other end of the hose to the Quick Coupler (11) on the Air Compressor. (See Figure D.)
3. Make sure the Pressure Switch (57) is in its “OFF” position. Then insert the Power Cord Plug (66) into the nearest 120 volt, grounded, electrical outlet. (See Figure D.)
3. Turn the Pressure Switch (57) to its “ON” position. (See Figure D.)
4. **NOTE:** The Compressor will automatically begin to run when the air pressure reaches **85 PSI** as indicated on the Tank Pressure Gauge (13) . When the maximum air pressure (**125 PSI**) is reached, the Compressor will automatically switch to idle and the Compressor will stop operating. The Compressor will automatically restart when the air pressure falls below **85 PSI**. (See Figure D.)
5. Allow about 15 minutes for the running Air Compressor to build up sufficient air capacity in its Air Tank (3). Then use the Pressure Regulator Knob (14) to increase or decrease the air flow to the pneumatic tool being used. (See Figure D.)

6. When finished using the Air Compressor, turn its Pressure Switch (57) to its “OFF” position. Then, unplug the unit from its electrical outlet. **(See Figure D.)**
7. Pull the ring on the Safety Valve (10) to release any remaining compressed air in the Air Tank (3) of the Compressor. **(See Figure D.)**
8. Squeeze the trigger of the pneumatic tool being used to release any remaining compressed air in the air hose and tool. Then disconnect the air hose from the tool and from the Air Compressor.
9. Slightly unscrew (no more than 4 turns) the water Drain Valve (4) to release any water condensation from the Air Tank (3). Then, retighten the Drain Valve. **(See Figure E.)**
10. Allow the Air Compressor to completely cool down. Then make sure to store the unit in a clean, dry, safe location out of reach of children and other unauthorized people.

ATTENTION!

This air compressor is designed for intermittent use. To help prolong the life of your air compressor it is recommended to allow a 30 minute cooling time between every half an hour of use. This product is not under warranty for Commerical purposes.

INSPECTION, MAINTENANCE, AND CLEANING

1.  **CAUTION!** Always make sure the Pressure Switch (57) of the Air Compressor is in its “OFF” position and the unit is unplugged from its electrical outlet prior to performing any service, maintenance, or cleaning of the Compressor.
2. **Before each use**, inspect the general condition of the Air Compressor. Check for loose screws, misalignment or binding of moving parts, cracked or broken parts, damaged electrical wiring, loose air fittings, and any other condition that may affect the safe operation of the Compressor. If abnormal noise or vibration occurs, have the problem corrected before further use.
Do not use damaged equipment.
3. **After each use**, open the water Drain Valve (4) under the Air Tank (3) to drain out the moisture. **(See Figure E.)**

4. **To clean**, wipe with a damp cloth, using a mild detergent. Never use solvents such as thinner, alcohol, trichloroethylene, etc. to clean the Air Compressor.
5. **To replace the Motor Carbon Brushes:** It may become necessary at sometime to replace or clean the two Carbon Brushes (68) when the Motor performance decreases, or stops working completely. **The Carbon Brushes are located on each side of the Motor Cover (46).** To replace the Carbon Brushes, remove the two Brush Holder Covers. Remove the Brush Caps. Then, remove the two the two Carbon Brushes from the two Brush Holders. If the Carbon Brushes are worn down more than 1/2, replace *both* Carbon Brushes. If, however, the Carbon Brushes are just dirty they may be cleaned by rubbing them with a pencil eraser. When installing the Carbon Brushes, make sure the carbon portion of the Carbon Brushes contact the Motor's Rotor and that the springs face away from the Motor. Also, make sure the springs operate freely. After replacement or cleaning, replace the two Brush Holder Covers. **NOTE:** New Carbon Brushes tend to arc or spark when first used until they wear and conform to the Motor's Rotor. **(See Assy. Diagram.)**
6. **To replace the Fuse:** An indicator of a blown Fuse (28) is if its wire strand within is burnt in half. When replacing the Fuse, make sure to install a new 15 AMP Buss Fuse.
7. Always store the Air Compressor in a clean, dry, safe location out of reach of children and other unauthorized people.
8.  **CAUTION! All maintenance, service, or repairs not mentioned in this manual must only be performed by a qualified service technician.**

PLEASE READ THE FOLLOWING CAREFULLY
--

THE MANUFACTURER AND/OR DISTRIBUTOR HAS PROVIDED THE PARTS LIST AND ASSEMBLY DIAGRAM IN THIS MANUAL AS A REFERENCE TOOL ONLY. NEITHER THE MANUFACTURER OR DISTRIBUTOR MAKES ANY REPRESENTATION OR WARRANTY OF ANY KIND TO THE BUYER THAT HE OR SHE IS QUALIFIED TO REPLACE ANY PARTS OF THE PRODUCT. IN FACT, THE MANUFACTURER AND/OR DISTRIBUTOR EXPRESSLY STATES THAT ALL REPAIRS AND PARTS REPLACEMENTS SHOULD BE UNDERTAKEN BY CERTIFIED AND LICENSED TECHNICIANS, AND NOT BY THE BUYER. THE BUYER ASSUMES ALL RISKS AND LIABILITY ARISING OUT OF HIS OR HER REPAIRS TO THE ORIGINAL PRODUCT OR REPLACEMENT PARTS THERETO, OR ARISING OUT OF HIS OR HER INSTALLATION OF REPLACEMENT PARTS THERETO.

TROUBLESHOOTING

Problem	Possible Cause	Possible Solution
Circuit breaker/fuse trip often.	<ol style="list-style-type: none"> 1. Excessive wire length causes voltage to drop too much. 2. Restricted air passages. 3. Back pressure in pump head. 	<ol style="list-style-type: none"> 1. Do not use an extension cord. Link additional air hoses together to acquire additional length. 2. Check all air passages for clogs. 3. Have a qualified service technician replace check valve and/or pressure switch bleeder valve.
Overheating.	<ol style="list-style-type: none"> 1. Poor ventilation. 2. Dirty cooling surfaces. 3. Leaking valve. 	<ol style="list-style-type: none"> 1. Relocate air compressor to an area with cool, dry, well circulated air. 2. Clean all cooling surfaces of pump and motor thoroughly. 3. Have a qualified service technician replace worn parts and re-assemble with new seals.
Motor stalls.	<ol style="list-style-type: none"> 1. Low voltage. 2. Defective pressure switch bleeder valve. 	<ol style="list-style-type: none"> 1. Do not use an extension cord. Link additional air hoses together to acquire additional length. 2. Have a qualified service technician replace defective pressure switch bleeder valve.
Pressure relief valve opens.	<ol style="list-style-type: none"> 1. Air tank pressure has exceeded normal operating pressure. 2. Pressure switch is stuck. 	<ol style="list-style-type: none"> 1. Have a qualified service technician replace pressure switch. 2. Have a qualified service technician replace pressure switch.
Motor will not run.	<ol style="list-style-type: none"> 1. Air tank pressure exceeds preset pressure switch limit. 2. Motor overload protection has been Tripped. 3. Air compressor attached to an extension cord. 	<ol style="list-style-type: none"> 1. Motor will automatically start when air tank pressure drops below 85 PSI pressure of air tank. 2. Replace blown fuse or reset circuit breaker. Do not use a fuse or circuit breaker with higher rating than specific for your circuit branch. Check for proper fuse; 15 AMP Buss fuse is acceptable. <p>Do not use an extension cord. Link additional air hoses together to acquire additional length.</p> <p>Disconnect other applications from circuit.</p> <p>Operate air compressor on a dedicated circuit.</p> <p>Bleed line by moving pressure switch lever to OFF position before restarting. If bleeder valve does not open, replace bleeder valve.</p> <p>Have a qualified service technician clean or replace motor.</p>

PARTS LIST

Part #	Description	Qty	Part #	Description	Qty
1	Screw (M6 x 25)	1	36	Outlet Valve Support	1
2	Rubber Support	1	37	Valve Plate	1
3	Air Tank	1	38	Inlet Valve Plate	1
4	Drain Valve	1	39	Washer	1
5	Wheel	2	40	Cylinder	1
6	Nut (M8 x 40)	2	41	Hex Screw (M6 x 35)	3
7	Screw (M6 x35)	4	42	Washer	3
8	Kit	1	43	Strap Wheel	1
9	Handle	1	44	Stator	1
10	Safety Valve	1	45	Armature	1
11	Quick Coupler	1	46	Cover	1
12	Screw (ST4 x 20)	13	47	Hex Screw (M5 x 95)	2
13	Tank/Tool Pressure Gauge	2	48	Connection Plate	2
14	Pressure Regulator Knob	1	49	Fan	1
15	1/4" Air Nozzle	1	50	Fan Cover	1
16	1/4" x 1/4" Tie-In	1	51	Valve	1
17	1/4" x 1/4" Fix Ring	1	52	Connector	1
18	Copper Nut	2	53	C5 Washer	2
19	Copper Tube	1	54	Air Nozzle Plug	2
20	Screw (M10 x 25)	1	55	Screw (M5 x 10)	2
21	Bearing (6203)	3	56	Ground Wire	2
22	Connecting Rod	1	57	Air Pressure Switch	1
23	Piston Ring	1	58	Strap	1
24	Back Plate	1	59	Transmission Shaft	1
25	Hex Screw (M6 x 15)	1	60	Eccentric Wheel	1
26	Copper Tube	1	61	Motor Support	1
27	1/2" x 1/2" Fix Ring	1	62	Stator Washer	1
28	Fuse	1	63	Over Heat Sensor	1
29	Upper Cover	1	64	Screw (ST4.2 x 15)	1
30	1/2" x 1/2" Plug	1	65	Strain Relief	1
31	Hex Bolt (M6 x 105)	4	66	Power Cord/Plug	1
32	Cylinder Head	1	67	O-Ring (6000)	2
33	Exhaust	1	68	Carbon Brush Assembly	2
34	Washer	1	69	Screw (ST4 x 10)	4
35	Head Gasket	1	70	Lower Cover	1
			71	Air Hose	1

NOTE:

Some parts are listed and shown for illustration purposes only,
and are not available individually as replacement parts.

ASSEMBLY DIAGRAM

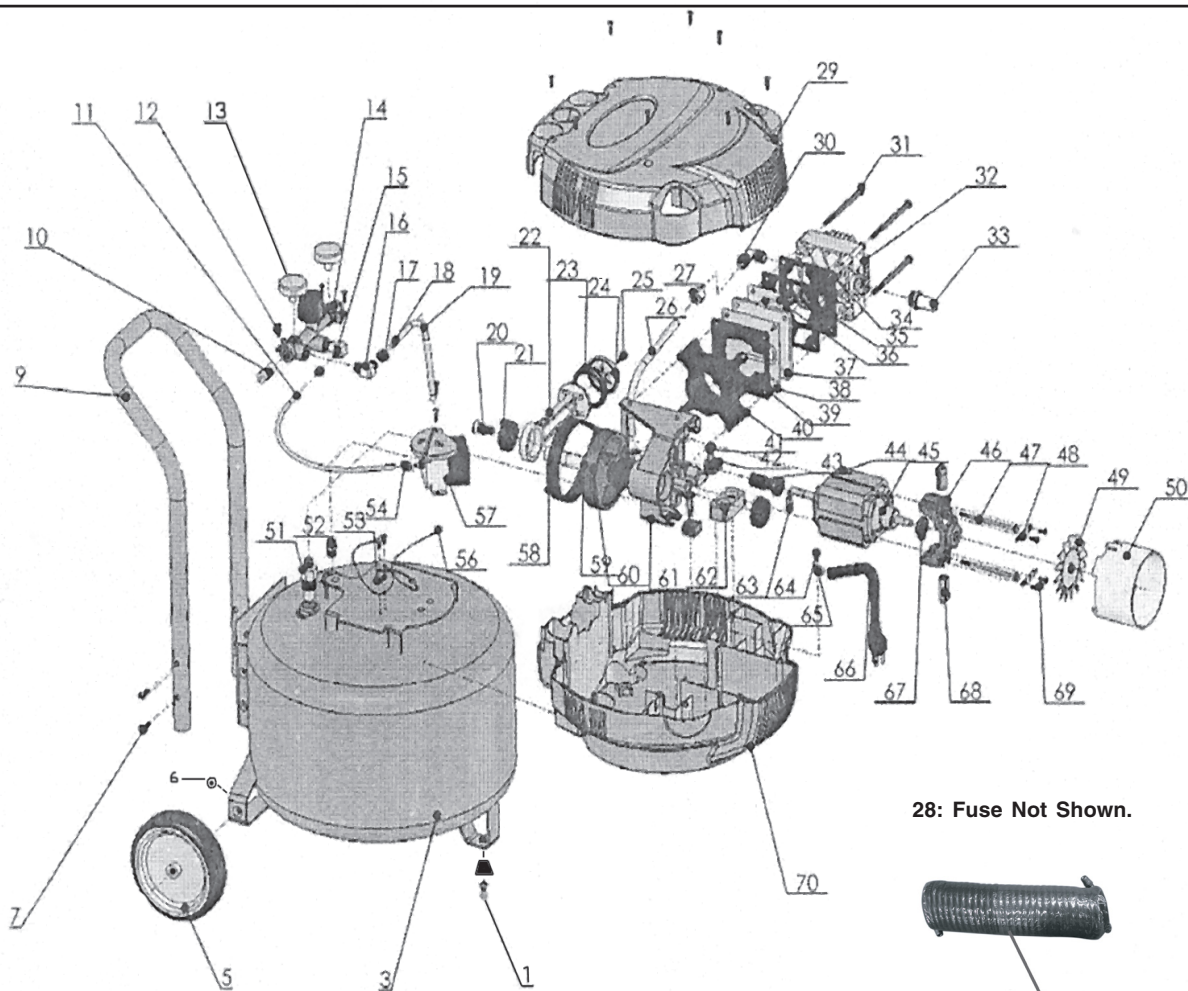

28: Fuse Not Shown.

NOTE:

Some parts are listed and shown for illustration purposes only, and are not available individually as replacement parts.

WARANTY

**CENTRAL
PNEUMATIC®**

**LIMITED 1 YEAR/
90 DAY WARRANTY**

Harbor Freight Tools Co. makes every effort to assure that its products meet high quality and durability standards, and warrants to the original purchaser that for a period of ninety days from date of purchase that the motor is free of defects in materials and workmanship. Harbor Freight Tools also warrants to the original purchaser, for a period of one year from date of purchase, that all other parts and components of the product are free from defects in materials and workmanship. This warranty does not apply to damage due directly or indirectly, to misuse, abuse, negligence or accidents, repairs or alterations outside our facilities, or to lack of maintenance. We shall in no event be liable for death, injuries to persons or property, or for incidental, contingent, special or consequential damages arising from the use of our product. Some states do not allow the exclusion or limitation of incidental or consequential damages, so the above limitation of exclusion may not apply to you. THIS WARRANTY IS EXPRESSLY IN LIEU OF ALL OTHER WARRANTIES, EXPRESS OR IMPLIED, INCLUDING THE WARRANTIES OF MERCHANTABILITY AND FITNESS.

To take advantage of this warranty, the product or part must be returned to us with transportation charges prepaid. Proof of purchase date and an explanation of the complaint must accompany the merchandise. If our inspection verifies the defect, we will either repair or replace the product at our election or we may elect to refund the purchase price if we cannot readily and quickly provide you with a replacement. We will return repaired products at our expense, but if we determine there is no defect, or that the defect resulted from causes not within the scope of our warranty, then you must bear the cost of returning the product.

This warranty gives you specific legal rights and you may also have other rights which vary from state to state.

3491 Mission Oaks Blvd. • PO Box 6009 • Camarillo, CA 93011 • (800) 444-3353

Free Manuals Download Website

<http://myh66.com>

<http://usermanuals.us>

<http://www.somanuals.com>

<http://www.4manuals.cc>

<http://www.manual-lib.com>

<http://www.404manual.com>

<http://www.luxmanual.com>

<http://aubethermostatmanual.com>

Golf course search by state

<http://golfingnear.com>

Email search by domain

<http://emailbydomain.com>

Auto manuals search

<http://auto.somanuals.com>

TV manuals search

<http://tv.somanuals.com>