

CENTRAL PNEUMATIC®

**TWIN TANK - 3HP PEAK
AIR COMPRESSOR**

Model 42321

**ASSEMBLY AND OPERATING
INSTRUCTIONS**



3491 Mission Oaks Blvd., Camarillo, CA 93011
Visit our Web site at <http://www.harborfreight.com>

Copyright© 2000 by Harbor Freight Tools®. All rights reserved. No portion of this manual or any artwork contained herein may be reproduced in any shape or form without the express written consent of Harbor Freight Tools.

For technical questions and replacement parts, please call 1-800-444-3353

REV 02/06

Specifications

ITEM	DESCRIPTION
Motor Power	3HP PEAK, 1-3/4 HP WORKING; 120 V~, 60 Hz, 1 Phase, 1720 RPM
Air Tank Size	5 gallons
Pump	Single stage
Air Outlet Fitting Size	1/4 inch NPT barbed
Air Delivery	3.8 CFM at 90 PSI; 4.5 CFM at 70 PSI, and 5 CFM at 40 PSI
Pressure Switch	On at 80 PSI; Unloader at 115 PSI, maximum pressure at 115 PSI
Net Weight	54.7 lbs.
Features	Pressure gauge Auto shutoff



UNPACKING

When unpacking, check to make sure all the parts shown on the **Parts List** at the end of the manual are included. If any parts are missing or broken, please call Harbor Freight Tools at the number shown on the cover of this manual as soon as possible.

SAVE THIS MANUAL

You will need this manual for the safety warnings and precautions, assembly, operating, inspection, maintenance and cleaning procedures, parts list and assembly diagram. Keep your invoice with this manual. Write the invoice number on the inside of the front cover. Keep this manual and invoice in a safe and dry place for future reference.

GENERAL SAFETY RULES



READ AND UNDERSTAND ALL INSTRUCTIONS
Failure to follow all instructions listed below may
result in electric shock, fire, and/or serious injury.

SAVE THESE INSTRUCTIONS

WORK AREA

1. **Keep your work area clean and well lit.** Cluttered benches and dark areas invite accidents.
2. **Do not operate compressors in explosive atmospheres, such as in the presence of flammable liquids, gases, or dust.** Compressors create sparks which may ignite the dust or fumes.
3. **Keep bystanders, children, and visitors away while operating a compressor.** Provide barriers or shields as needed.

ELECTRICAL SAFETY

1. **Grounded compressors must be plugged into an outlet properly installed and grounded in accordance with all codes and ordinances. Never remove the grounding prong or modify the plug in any way. Do not use any adapter plugs. Check with a qualified electrician if you are in doubt as to whether the outlet is properly grounded.** If the compressors should electrically malfunction or break down, grounding provides a low resistance path to carry electricity away from the user.
2. **Do not expose compressors to rain or wet conditions.** Water entering an electric motor will increase the risk of electric shock.
3. **Do not abuse the Power Cord. Never use the Power Cord to pull the Plug from an outlet. Keep the Power Cord away from heat, oil, sharp edges, or moving parts. Replace damaged Power Cords immediately.** Damaged Power Cords increase the risk of electric shock.
4. **AN EXTENSION CORD MUST NEVER BE USED WITH THIS ITEM. Connecting this item to an outlet through an extension cord MAY CAUSE ELECTRICAL DAMAGE TO THE MOTOR and could present a FIRE HAZARD.**

PERSONAL SAFETY

1. **Stay alert. Watch what you are doing, and use common sense during use. Do not use while tired or under the influence of drugs, alcohol, or medication.** A moment of inattention while operating may result in serious personal injury.
2. **Dress properly. Do not wear loose clothing or jewelry. Contain long hair. Keep your hair, clothing, and gloves away from moving parts.** Loose clothes, jewelry, or long hair can be caught in moving parts.
3. **Avoid accidental starting. Be sure the Power Switch is turned off before plugging in.** Plugging in compressors with the Power Switch on, invites accidents.
4. **Remove adjusting keys or wrenches before turning the compressor on.** A wrench or a key that is left attached to a rotating part of the compressor may result in personal injury.
5. **Do not overreach. Keep proper footing and balance at all times.**

6. **Use safety equipment. Always wear eye protection.** Make sure you are wearing your protective clothing, safety glasses with side shields and dust mask or air respirator, if appropriate.

TOOL USE AND CARE

1. **Do not force the compressor. Use the correct compressor for your application.** The correct compressor will do the job better and safer at the rate for which it is designed. Never attempt to force the compressor to provide more pressure than it was designed for.
2. **Do not use the compressor if the Power Switch does not turn it on or turn it off.** Any compressor that cannot be controlled with the Power Switch is dangerous and must be repaired or replaced.
3. **Disconnect the Power Cord Plug from the power source before making any adjustments, changing accessories, or storing the compressor.** Such preventive safety measures reduce the risk of starting the compressor accidentally.
4. **Keep idle compressors out of reach of children and other untrained persons.** Compressors are dangerous in the hands of untrained users.
5. **Maintain compressors with care. Keep all components of this product clean and dry.** Do not use a damaged compressor. Tag damaged compressors "Do not use" until repaired.
6. **Check for misalignment or binding of moving parts, breakage of parts, and any other condition that may affect the compressor's operation. If damaged, have the compressor serviced before using.** Many accidents are caused by poorly maintained compressors.
7. **Use only accessories that are recommended by the manufacturer for your model.** Accessories that may be suitable for one compressor may become hazardous when used on another compressor.

SERVICE



1. **Compressor service must be performed only by qualified repair personnel.** Service or maintenance performed by unqualified personnel could result in a risk of injury.
2. **When servicing a compressor, use only identical replacement parts. Follow instructions in the "Inspection, Maintenance, And Cleaning" section of this manual.** Use of unauthorized parts or failure to follow maintenance instructions may create a risk of electric shock or injury.

SPECIFIC SAFETY RULES

1. **CAUTION! Prior to its *first* use, and thereafter prior to each *subsequent* use, make sure to fill the Air Compressor with a premium quality, 30 weight, non-detergent oil to the specified level.** Running the Air Compressor with no oil or with low oil will

cause damage to the equipment and void its warranty. Refer to the “*Operating Instructions*” section for details on filling the Air Compressor with oil.

2. **When filling the Air Compressor with oil, make sure to *unscrew* (do not pull) the Oil Fill Cap to remove.**
3. **Use eye and ear protection.** Always wear ANSI-approved safety impact eye goggles, and ear plugs when using the Air Compressor.
4. **Make sure all tools and equipment used with the Air Compressor are rated to the appropriate air pressure capacity of the Air Compressor.** Do not use any tool or equipment that does not operate from 0-115 PSI. If necessary, check the owner’s manual of the tool or equipment for its air pressure rating.
5. **Always disconnect the Air Compressor from its electrical outlet, release any remaining air pressure from the unit, and disconnect all pneumatic tools and equipment from the unit, before performing any services or maintenance.**
6. **Avoid injury. Never direct the air jet at people or animals.**
7. **Inspect safety valve daily.** If the safety valve is not working properly, tank pressure can build up to dangerous levels. The tank could explode. For this reason, pull the ring on the safety valve before each use and verify that it operates freely. Replace safety valve if it does not operate freely.
Never remove or alter the factory sealed Safety Release Valve.
8. **Do not attempt to readjust the automatic start and shutoff valves.** Any change to the automatic ON/OFF pressure levels will cause additional stress on the motor, which may result in shortened motor life.
9. **Drain the Air Compressor’s air tank every day.** Do not allow moisture to build up inside the Air Tank.
10. **Do not unscrew the tank drain valve so that *more than* four threads are showing.**
11. **Avoid risk of tank explosion.**
 - a) Avoid weakening of tank by draining condensation after each use.
 - b) Never modify tank by drilling holes, welding to it, or modifying it’s parts.
 - c) The tank is designed, and factory set, to operate within a specific pressure range. For that reason, never make adjustments to, or substitute parts, to the compressor.
12. **Avoid bodily injury from moving parts.** The compressor cycles on automatically, without notice. For this reason, always keep hands and arms away from compressor parts when the unit is connected to electrical power. Always have compressor safety guards in place before turning compressor on.
13. **Use approved air hose.** Never use plastic or PVC pipe (unless specified for Air Compressors) to carry air under pressure. Regardless of its pressure rating, it can burst under pressure. Use only metal pipe.
14. **Never plug the power cord of this product into an electrical outlet while standing on a wet or damp surface.**

15. **THIS AIR COMPRESSOR MAY REQUIRE A DEDICATED ELECTRICAL CIRCUIT AS THE AMPERAGE DRAW UNDER FULL LOAD, COMBINED WITH USE OF ANY OTHER ITEM, MAY OVERLOAD YOUR CIRCUIT.**
16. **Always turn off the Air Compressor in the event of a power failure.**
17. **Performance of this Air Compressor may vary depending on variations in local line voltage.**
18. **Maintain labels and nameplates on the Air Compressor.** These carry important information. If unreadable or missing, contact Harbor Freight Tools for a replacement.
19.  **WARNING!** People with pacemakers should consult their physician(s) before using this product. Electromagnetic fields in close proximity to a heart pacemaker could cause interference to or failure of the pacemaker.
20.  **WARNING!** The brass components of this product contain lead, a chemical known to the State of California to cause birth defects (or other reproductive harm). (California Health & Safety code § 25249.5, *et seq.*)
21.  **WARNING!** The warnings, precautions, and instructions discussed in this instruction manual cannot cover all possible conditions and situations that may occur. It must be understood by the operator that common sense and caution are factors which cannot be built into this product, but must be supplied by the operator.

SAVE THESE INSTRUCTIONS

Setup

Dipstick

Warning: Fill compressor with oil before using; running with NO OIL or with LOW OIL will void the warranty. The optimal capacity of the oil reservoir is 7.8 ounces of oil.

The Dipstick is used to determine if oil is needed. **Never operate the compressor without sufficient oil.** Use a 30 weight, non-detergent compressor oil. To check the oil:

1. Unscrew the Dipstick.
2. Check the level of the oil. There are two lines on the bottom of the Dipstick. **The oil level should be somewhere between the two lines, as high as possible.**
3. Add oil through the Gauge's hole as necessary, but do not overfill. Always use a high grade oil specially designed for air compressors. Never mix oils of different types. Never use a low quality oil which may not afford adequate lubrication.
4. Replace the Dipstick.

Install an Air Intake Filter and Hose (not included)

The filter and oiler (not supplied) are recommended but not mandatory for operation.

1. Remove and discard the plastic cap which covers the threaded hole at the top of the Cylinder Case (B-6).
2. Screw the threaded part of the air filter assembly into the Cylinder Case until it is firmly seated.
3. Connect the air tool, air hoses, filter, and oiler to the Compressor Air Output as illustrated on the next page.

If the filter and oiler are not used, connect the air hose directly to the 1/4 inch NPT barbed connector located at the Air Flow Valve (A-8). For easy connection or removal, a quick coupler should be installed on the end of the air output.

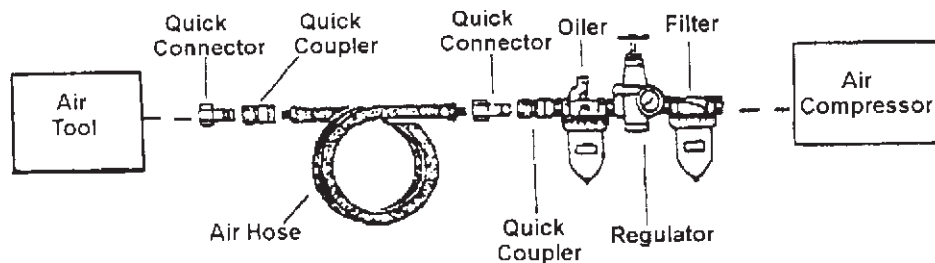

Note: Use pipe thread seal tape on all threaded connections.

Operation

Caution: Prior to use, inspect the compressor or any damaged parts or unsafe conditions. Make any necessary repairs before using again.

Turning Compressor On

1. Verify Tank Drain Valve (A-7) is closed.
2. **Verify oil level is correct.**
3. Verify that the Safety Valve (A-4) is operational.
4. Turn the Air Flow Valve (A-8) to the OFF position.
5. Plug the power cord into a electrical outlet with a grounding prong.
6. Turn the ON/OFF Switch Lever(A-5) down to turn on. Turn the Switch Lever up to shut off.Allow the pressure to build up to at least 80 PSI before using air.
7. Open the Air Flow Valve (A-8) and check for air leaks.

The operation of the compressor is automatic, as controlled by the an internal pressure switch. When the pressure drops below its operating range the compressor turns on. When the pressure is above 115 PSI, the compressor shuts off.

Warning; The compressor may become very hot during operation. Do not touch the cylinder area of the compressor, or allow flammable materials to come in contact with the cylinder area.

Adjusting Pressure Gauge and Pressure Adjustment Screw

Caution: The Pressure Switch is adjustable but changes to the pressure levels are not recommended; any change to the automatic ON/OFF pressure levels will cause additional stress on the motor which may shorten motor life.

Adjusting Air Output

1. When the Lever of the Air Flow Valve (A-8) is to the up or down position, the valve is closed. When it is in the middle, it is open.
2. Turn the Air Flow Valve to the appropriate pressure.

Maintenance

Warning: Do not make any repairs, adjustments, or maintenance on the air compressor unless it is disconnected from the electrical power and the tank pressure is released.

Maintenance should always be performed by a qualified technician.

1. **Check the oil level before each use. If the oil is low, add some. If it is high, drain some by removing the Drain Plug. Replace the oil once a year.**
2. Check and clean the Air Filter (B-5) every 50 hours, or sooner if used in a dusty environment.

3. Drain the air tanks after each use by opening the drain petcock or the Tank Drain Valve (A-7). Leave open until the next use.
4. Clean compressor with a damp rag containing mild detergent and water. Do not use flammable liquids or solvents.

Parts List “A”

Item #	Description	Qty
A-1	Compressor Assembly	1
A-2	Pressure Gauge	1
A-3	Rubber Grip	1
A-4	Safety Valve	1
A-5	ON/OFF Switch	1
A-6	Air Tank	2
A-7	Tank Drain Valve	1
A-8	Air Flow Valve	1
A-9	One Way Valve	1
A-10	Tube	1
A-11	Base	1
A-12	Rubber Foot	4
A-13	Bolt and Nut	1 ea.

NOTE: Some parts are listed and shown for illustration purposes only and are not available individually as replacement parts.

PLEASE READ THE FOLLOWING CAREFULLY

THE MANUFACTURER AND/OR DISTRIBUTOR HAS PROVIDED THE PARTS DIAGRAM IN THIS MANUAL AS A REFERENCE TOOL ONLY. NEITHER THE MANUFACTURER NOR DISTRIBUTOR MAKES ANY REPRESENTATION OR WARRANTY OF ANY KIND TO THE BUYER THAT HE OR SHE IS QUALIFIED TO MAKE ANY REPAIRS TO THE PRODUCT OR THAT HE OR SHE IS QUALIFIED TO REPLACE ANY PARTS OF THE PRODUCT. IN FACT, THE MANUFACTURER AND/OR DISTRIBUTOR EXPRESSLY STATES THAT ALL REPAIRS AND PARTS REPLACEMENTS SHOULD BE UNDERTAKEN BY CERTIFIED AND LICENSED TECHNICIANS AND NOT BY THE BUYER. THE BUYER ASSUMES ALL RISK AND LIABILITY ARISING OUT OF HIS OR HER REPAIRS TO THE ORIGINAL PRODUCT OR REPLACEMENT PARTS THERETO, OR ARISING OUT OF HIS OR HER INSTALLATION OF REPLACEMENT PARTS THERETO.

Assembly Drawing "A"

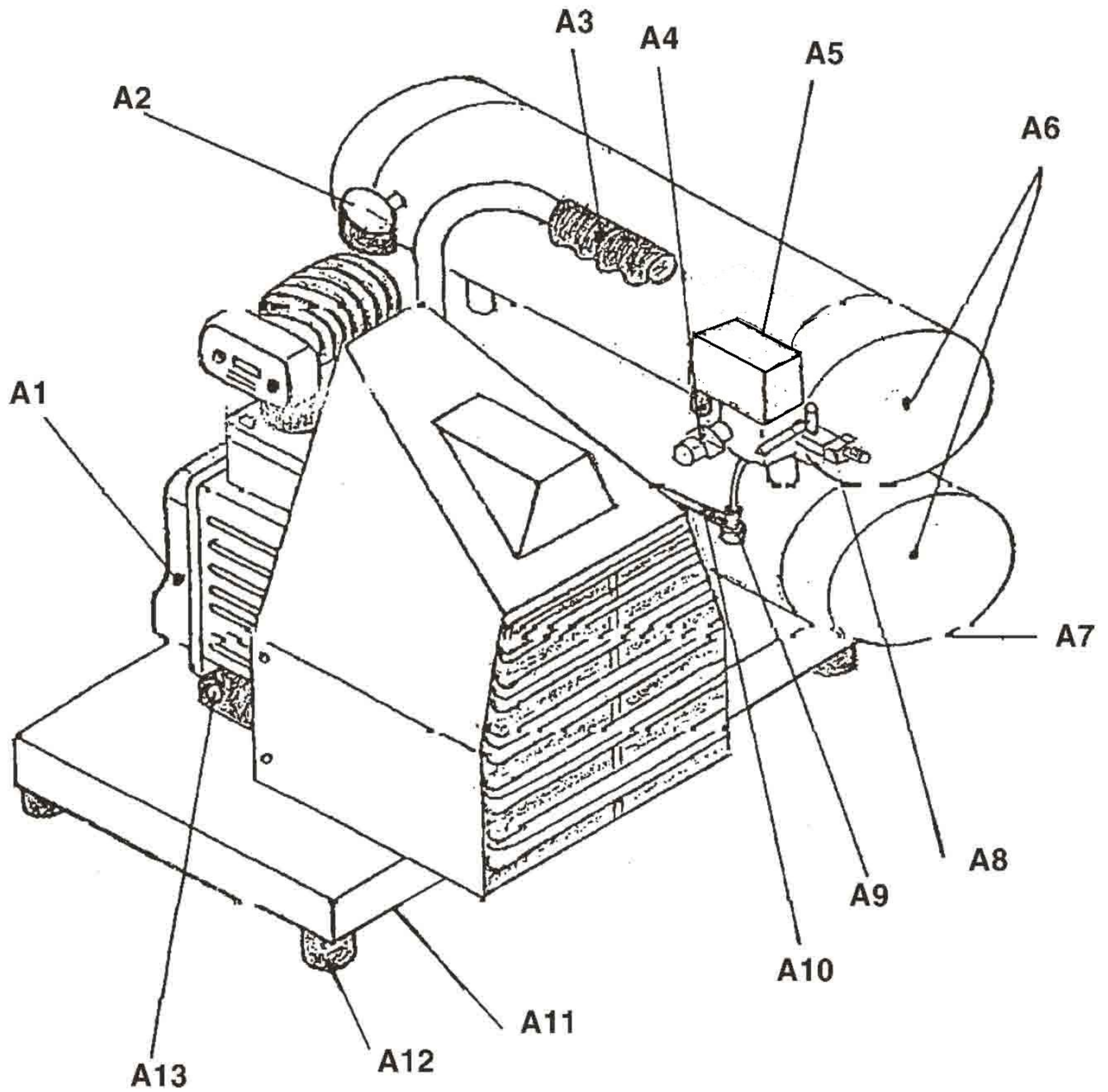

Parts List "B"

Item	Description	Qty
B-1	Screw	4
B-2	Screw	2
B-3	Washer	2
B-4	Washer	4
B-5	Air Fliter	1
B-6	Cylinder Case	1
B-7	Gasket, Crankshaft Cover	1
B-8	Valve Seat	1
B-9	Gasket, Valve Seat	1
B-10	Valve Plate	2
B-11	Valve Seat	1
B-12	Gasket, Valve Seat	1
B-13	Cylinder	1
B-14	Cylinder Gasket	1
B-15	Compression Ring	2
B-16	Scraping Oil Ring	1
B-17	Piston	1
B-18	Piston Pin	1
B-19	Crankshaft Retainer	2
B-20	Dip Stick	1
B-21	Screw	1

Item	Description	Qty
B-22	Connecting Rod	1
B-23	Crankshaft	1
B-24	Gasket, Front Cover	1
B-25	Front Cover	1
B-26	Washer	1
B-27	Washer	4
B-28	Bolt - Oil Drain	1
B-29	Screw	4
B-30	Crankshaft Case	1
B-31	Nut	2
B-32	Seal Washer	2
B-33	Bearing	1
B-34	Electric Capacitor	2
B-35	Bolt	3
B-36	Screw	4
B-37	Motor	1
B-38	Washer	4
B-39	Radiating Fan Wheel	1
B-40	Radiating Cover	1
B-41	Thermal Switch	1

NOTE: Some parts are listed and shown for illustration purposes only and are not available individually as replacement parts

Assembly Drawing "B"

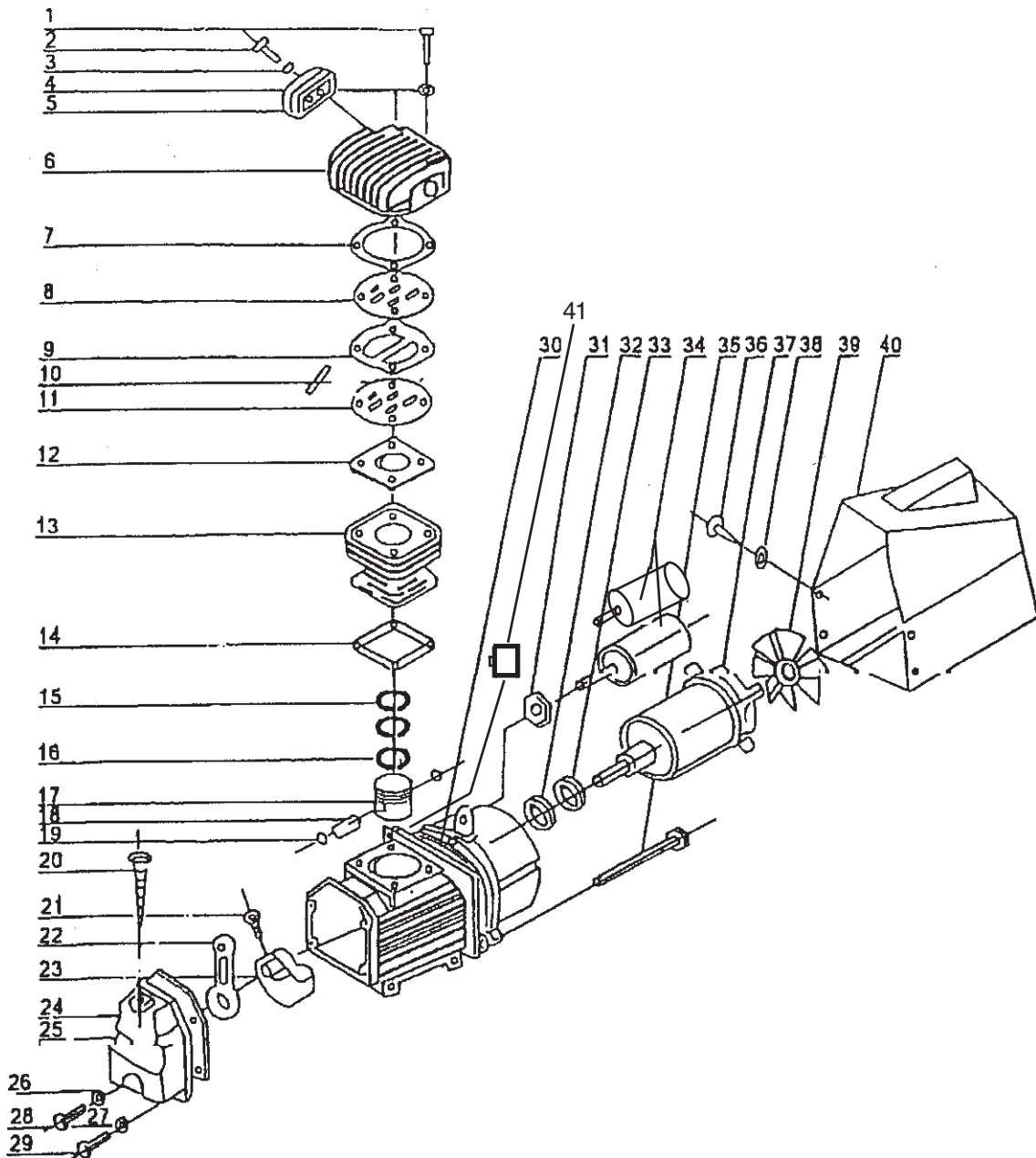

When ordering parts on this page, add the prefix "B" to the part number (Example: B-1 is a Screw)

Free Manuals Download Website

<http://myh66.com>

<http://usermanuals.us>

<http://www.somanuals.com>

<http://www.4manuals.cc>

<http://www.manual-lib.com>

<http://www.404manual.com>

<http://www.luxmanual.com>

<http://aubethermostatmanual.com>

Golf course search by state

<http://golfingnear.com>

Email search by domain

<http://emailbydomain.com>

Auto manuals search

<http://auto.somanuals.com>

TV manuals search

<http://tv.somanuals.com>