

# Sweep Tractor Assembly Instructions

PNEG-1597

Date: 02-28-08

GSI GROUP



PNEG-1597

---

## General Information

- A. We reserve the right to improve our product whenever possible and practical to do so. We reserve the right to change, improve, and modify products at any time without obligation to make changes, improvements, and modifications on equipment sold previously.
- B. The Sweep Tractor has been designed and manufactured to give years of dependable service. The care and maintenance of this machine will affect the satisfaction and service obtained. By observing the instructions and suggestions we have recommended, the owner should receive competent service for many years. If additional information or assistance should be required, please contact the factory or your local dealer.

### C. Receiving Merchandise and Filing Claims

- i. When receiving merchandise, it is important to check both the quantity of parts and their descriptions with the packing list enclosed within each package. All claims for freight damage or shortage must be made by the consignee within ten (10) days from the date of the occurrence of freight damage. The consignee should accept the shipment after noting the damage or loss.

#### For Claims Contact:

**GSI Group  
1004 East Illinois St.  
Assumption, IL 62510  
Phone: 217-226-4421  
Fax: 217-226-4420**

**Personnel operating or working around this equipment should read this manual. This manual must be delivered with equipment to its owner. Failure to read this manual and its safety instructions is a misuse of the equipment. Any misuse of the equipment may void the warranty.**

---

# Contents

<b>Chapter 1 Safety</b> .....	<b>5</b>
Safety Guidelines .....	5
Safety Instructions .....	6
<b>Chapter 2 Safety Decals</b> .....	<b>11</b>
<b>Chapter 3 Assembly</b> .....	<b>12</b>
Sweep Tractor Assembly .....	12
End Wheel Assembly .....	22
Sweep Tractor to Shield Assembly .....	23
<b>Chapter 4 Parts List</b> .....	<b>24</b>
Sweep Tractor Parts .....	24
End Wheel Parts .....	26
<b>Chapter 5 Warranty</b> .....	<b>27</b>



*Replace missing guards and shields*  
**FREE OF CHARGE!**

GSI equipment is built to provide many years of dependable service to our customers through durable craftsmanship.

One of the most important aspects of GSI engineering is **SAFETY 1<sup>st</sup>** design throughout all product lines. At GSI - Safety is NO ACCIDENT!

That is why GSI is implementing its **SAFETY 1<sup>st</sup>** program. Should you ever need guards, shields, safety decals, or owner/operator manuals, simply contact GSI, and we will supply you with them **FREE OF CHARGE!**

While it is our main goal for GSI to be the world leader in auger manufacturing, it is always our first priority to keep our customers safe.

If you need any of the above listed safety items or have safety questions, please contact GSI:

GSI Group  
PO Box 20  
1004 E. Illinois St.  
Assumption, IL 62510  
Ph: 217-226-4421

## Safety Guidelines

This manual contains information that is important for you, the owner/operator, to know and understand. This information relates to protecting **personal safety** and **preventing equipment problems**. It is the responsibility of the owner/operator to inform anyone operating or working in the area of this equipment of these safety guidelines. To help you recognize this information, we use the symbols that are defined below. Please read the manual and pay attention to these sections. Failure to read this manual and its safety instructions is a misuse of the equipment and may lead to serious injury or death.



**This is the safety alert symbol. It is used to alert you to potential personal injury hazards. Obey all safety messages that follow this symbol to avoid possible injury or death.**



**DANGER** indicates an imminently hazardous situation which, if not avoided, will result in death or serious injury.



**WARNING** indicates a potentially hazardous situation which, if not avoided, could result in death or serious injury.



**CAUTION** indicates a potentially hazardous situation which, if not avoided, may result in minor or moderate injury.



**CAUTION** used without the safety alert symbol indicates a potentially hazardous situation which, if not avoided, may result in property damage.



**NOTE** indicates information about the equipment that you should pay special attention.

### Safety Instructions

Our foremost concern is your safety and the safety of others associated with this equipment. We want to keep you as a customer. This manual is to help you understand safe operating procedures and some problems which may be encountered by the operator and other personnel.

As owner and/or operator, it is your responsibility to know what requirements, hazards and precautions exist, and to inform all personnel associated with the equipment or in the area. Safety precautions may be required from the personnel. Avoid any alterations to the equipment. Such alterations may produce a very dangerous situation where SERIOUS INJURY or DEATH may occur.

This equipment shall be installed in accordance with the current installation codes and applicable regulations which should be carefully followed in all cases. Authorities having jurisdiction should be consulted before installations are made.

#### Follow Safety Instructions

Carefully read all safety messages in this manual and safety signs on your machine. Keep signs in good condition. Replace missing or damaged safety signs. Be sure new equipment components and repair parts include the current safety signs. Replacement safety signs are available from the manufacturer.

Learn how to operate the machine and how to use controls properly. Do not let anyone operate without instruction.

Keep your machinery in proper working condition. Unauthorized modifications to the machine may impair the function and/or safety and affect machine life.

If you do not understand any part of this manual or need assistance, contact your dealer.

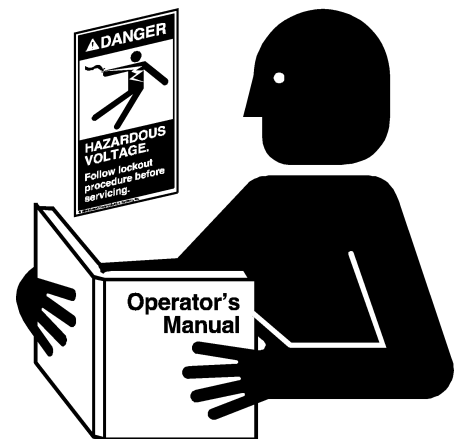

**Read and Understand Manual**

#### Practice Safe Maintenance

Understand service procedures before doing work. Keep area clean and dry.

Never lubricate, service, or adjust machine while it is in operation. Keep hands, feet and clothing away from rotating parts.

Keep all parts in good condition and properly installed. Fix damage immediately. Replace worn or broken parts. Remove any built up grease oil and debris.



**Maintain Equipment and Work Area**

## Wear Protective Clothing

Wear close fitting clothing and safety equipment appropriate to the job.

Remove all jewelry.

Long hair should be tied up and back.

Safety glasses should be worn at all times to protect eyes from debris.

Wear gloves to protect your hands from sharp edges on plastic or steel parts.

Wear steel toe boots to help protect your feet from falling debris. Tuck in any loose or dangling shoe strings.

A respirator may be needed to prevent breathing potentially toxic fumes and dust.

Wear hard hat to help protect your head.

**Eye Protection**

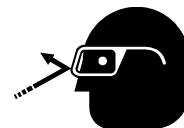

**Gloves**



**Steel Toe Boots**



**Respirator**



**Hard Hat**



## Prepare for Emergencies

Be prepared if fire starts.

Keep a first aid kit and fire extinguisher handy.

Keep emergency numbers for doctors, ambulance service, hospital and fire department near your telephone.

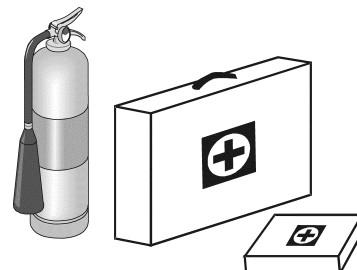

**Keep Emergency Equipment Quickly Accessible**

### General Safety Guidelines

- A. **DO NOT** make any alterations to the equipment. Such alterations may produce a very dangerous situation, where **SERIOUS INJURY** or **DEATH** may occur.
- B. This equipment shall be installed in accordance with any regulations or installation codes that are required by law. Authorities having jurisdiction should be consulted before installations are made.
- C. Untrained operators subject themselves and others to **SERIOUS INJURY** or **DEATH. NEVER** allow untrained personnel to operate this equipment.
- D. Keep children and other unqualified personnel out of the working area at **ALL** times.
- E. **NEVER** start equipment until **ALL** persons are clear of the work area.
- F. Be sure **ALL** operators are adequately rested and prepared to perform **ALL** functions of operating this equipment.
- G. Keep hair, loose clothing, and shoestrings away from rotating and moving parts. **NEVER** wear loose fitting clothing when working around augers.
- H. **NEVER** allow any person intoxicated or under the influence of alcohol or drugs to operate the equipment.
- I. **NEVER** allow anyone inside a bin, truck, or wagon which is being unloaded by an auger or conveyor. Flowing grain can trap and suffocate in seconds.
- J. Make sure someone is nearby who is aware of the proper shutdown sequence in the event of an accident or emergency.
- K. **NEVER** work alone.
- L. **ALWAYS** think before acting. **NEVER** act impulsively around the equipment.
- M. Make sure **ALL** equipment is locked in position before operating.
- N. Keep hands and feet away from the auger intake and other moving parts.
- O. **NEVER** attempt to assist machinery operation or to remove trash from equipment while in operation.
- P. Use ample overhead lighting after sunset to light the work area.
- Q. **ALWAYS** lock out **ALL** power to the equipment when finished unloading.
- R. Keep area around intake free of obstacles such as electrical cords, blocks, etc. that might trip workers.



---

## Hazards

- A. **Keep clear of all augers. DO NOT ENTER the bin.**
- B. If you must enter this bin:
  - 1. Shut OFF and lock out all power.
  - 2. Use safety harness and safety line.
  - 3. Station another person outside the bin.
  - 4. Avoid the center of the bin.
  - 5. Wear proper breathing equipment or respirator.
- C. **Failure to heed these warnings will result in serious injury or death.**
- D. **Be cautious of Pinch Points. A *Pinch Point* is a narrow area between two surfaces that is likely to trap or catch objects and so is a potential safety hazard.**

## Shields and Guards

- A. **ALWAYS** keep **ALL** shields and guards in place during operation.

**We will replace any missing shields or guards free of charge.**

*Refer [Page 4](#) for more information on our Safety First program.*



## 2. Safety Decals

Check components shown below to ensure that the safety decals are in place and in good condition. If a decal cannot be easily read for any reason or has been painted over, replace it immediately. Contact your dealer or the manufacturer to order a replacement decal free of charge.

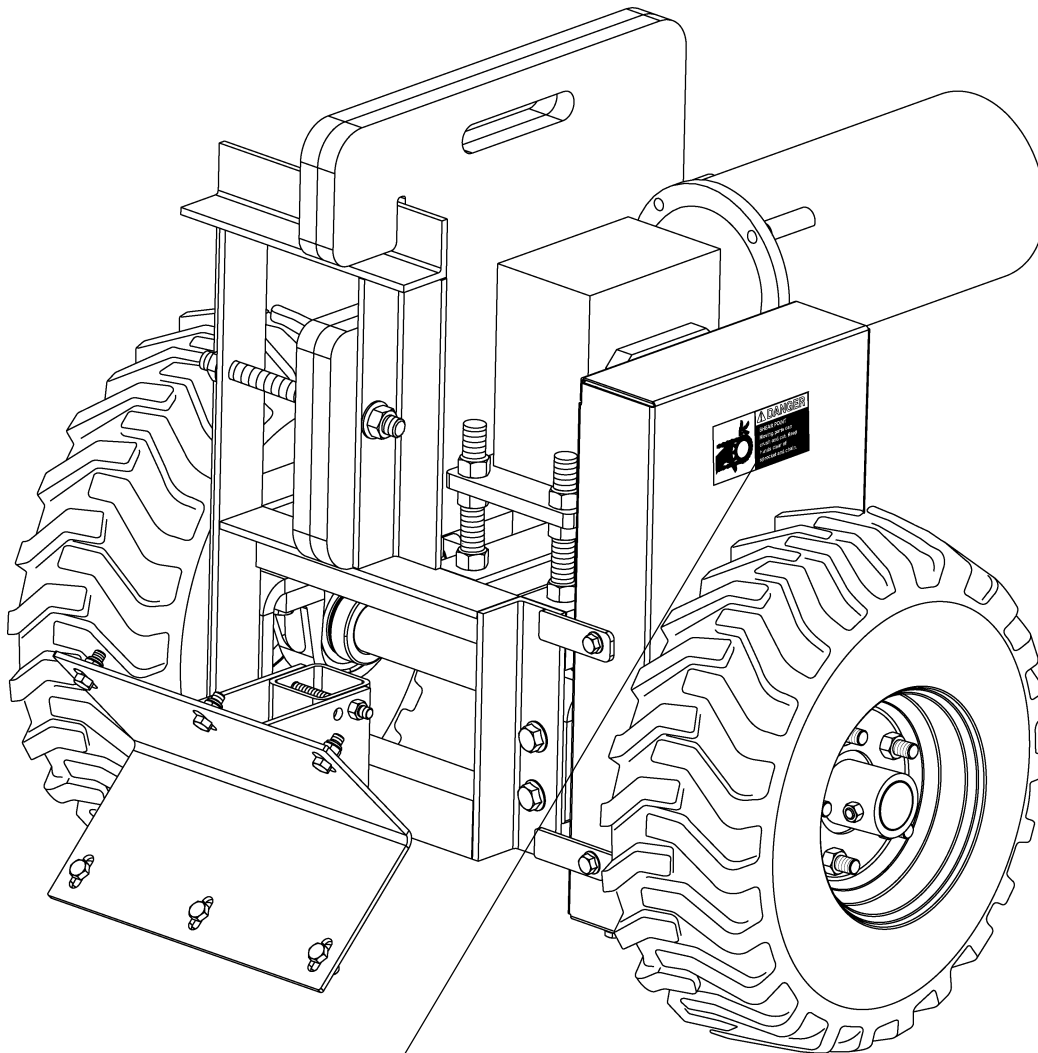

DC-1382      Decals located on outside of chain guards.

### 3. Assembly

## Sweep Tractor Assembly

1. Place the tractor frame on plain flat ground and remove the bolts from the tractor frame.
2. Bolt the pillow block bearing to the bearing mount bracket using two (2) 1/2"-13 x 2" **hex head cap screws**, two (2) **flat washers**, and two (2) 1/2"-13 **serrated flanged nuts**.
3. Bolt the bearing mount bracket to the tractor frame using two (2) 1/2"-13 x 1-1/4" **flanged bolts** and two (2) 1/2"-13 **serrated flanged nuts** on either side (L.H. and R.H.) of the tractor frame.

**NOTE:** Lock collar flange must be to inside of frame.

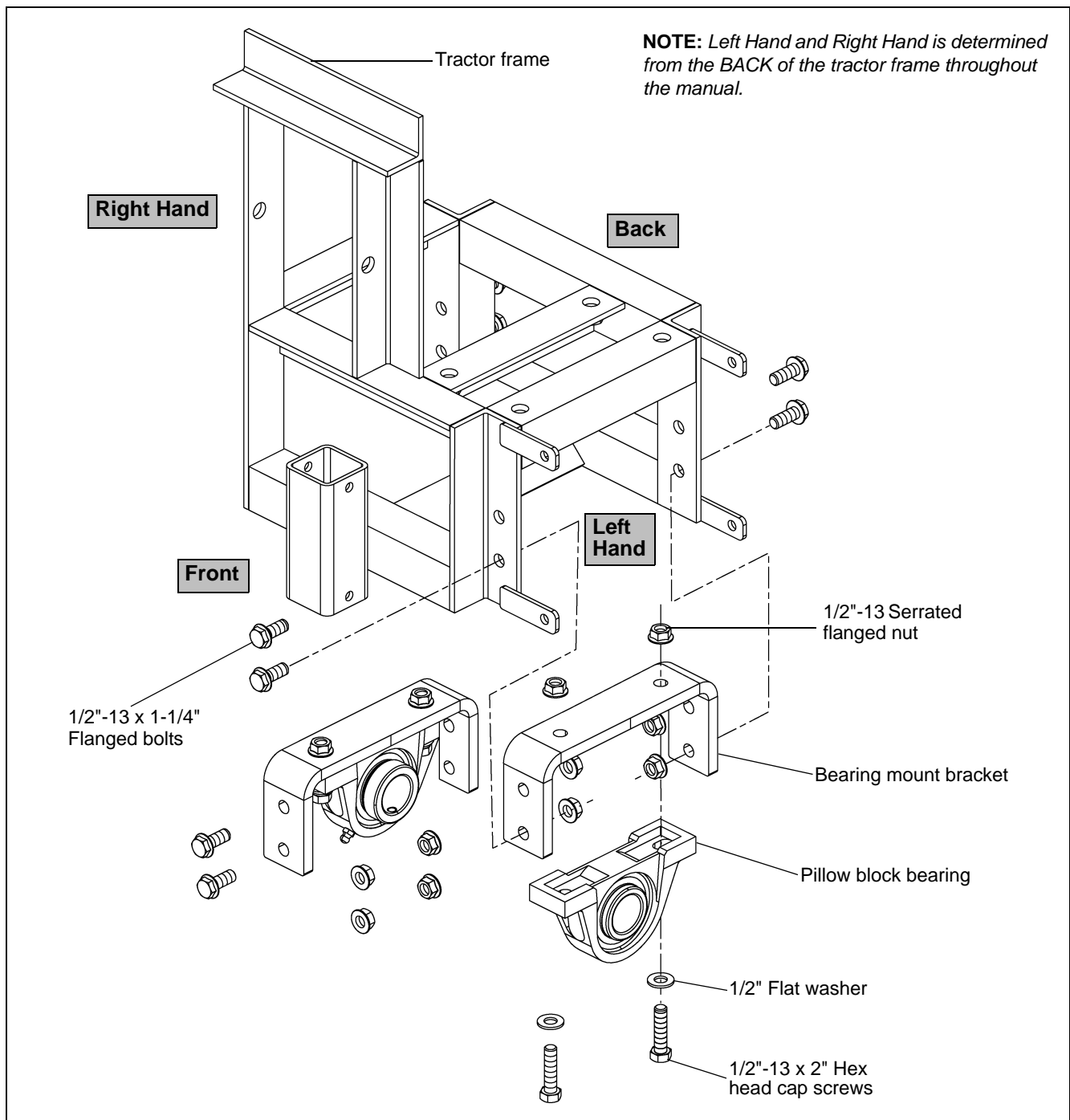

Figure 3A

- Slide the tractor axle (shaft) through the left side of the pillow block bearing and the lock collars so as to pass through the right side of the pillow block bearing. Make sure the keyway is on the left hand side.

**NOTE:** Do not tighten lock collars.

- Assemble the 40 tooth sprocket to the tractor axle (shaft) using square key (3/8" x 1-3/4" long).
- Mount the wheel hub to the tractor axle (shaft) using 3/8"-16 x 2-1/2" hex head cap screw and 3/8"-16 stover lock nut.

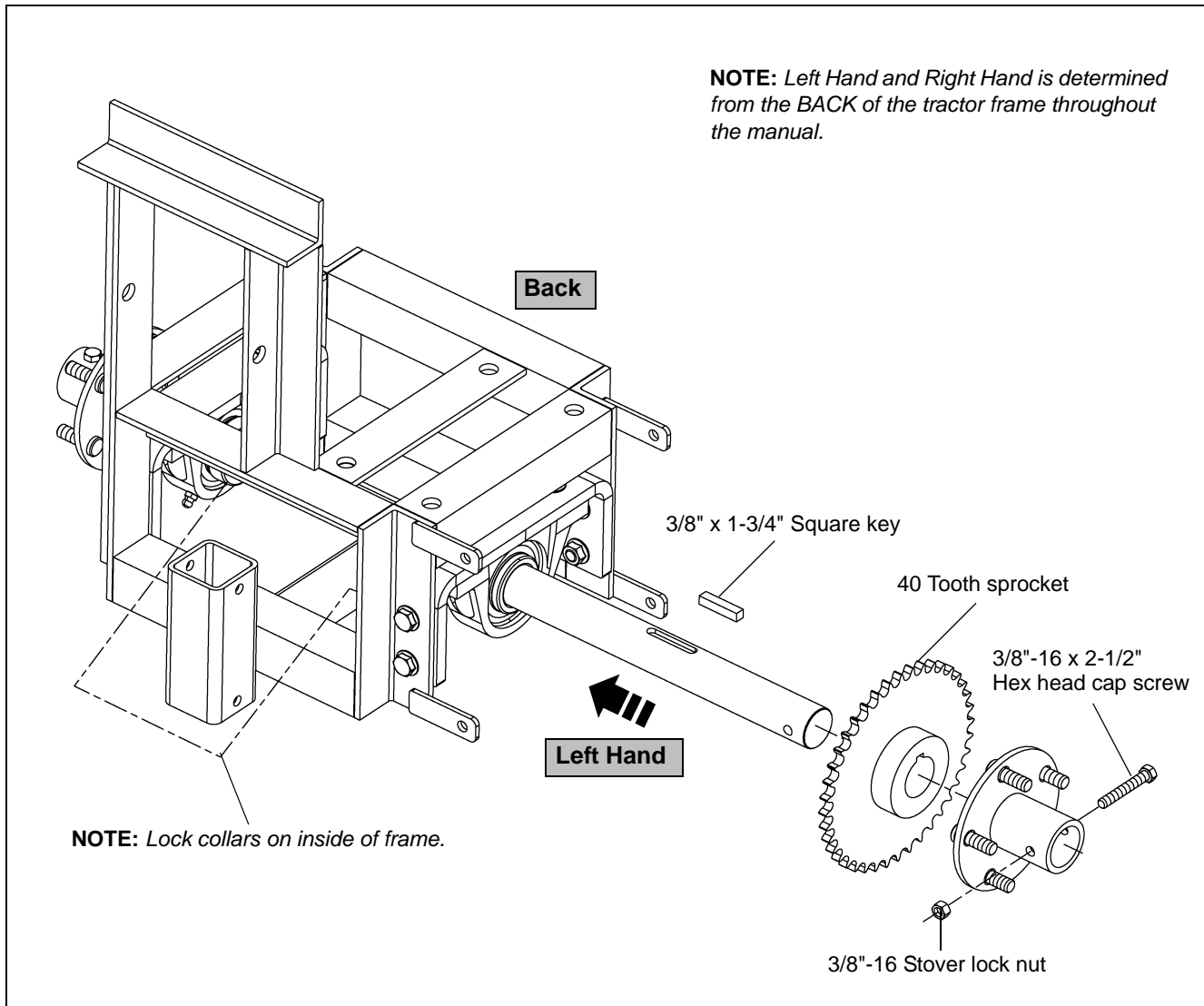

Figure 3B

### 3. Assembly

7. Assemble the tire securely to the wheel hub using five (5) 1/2"-20 lug nuts.

**NOTE:** Make sure that the tires are assembled on corresponding sides with the help of valve stem, and remove the screws or nails that are present in the tires. The tires are foam filled. The treads of the tires should be in the forward direction.

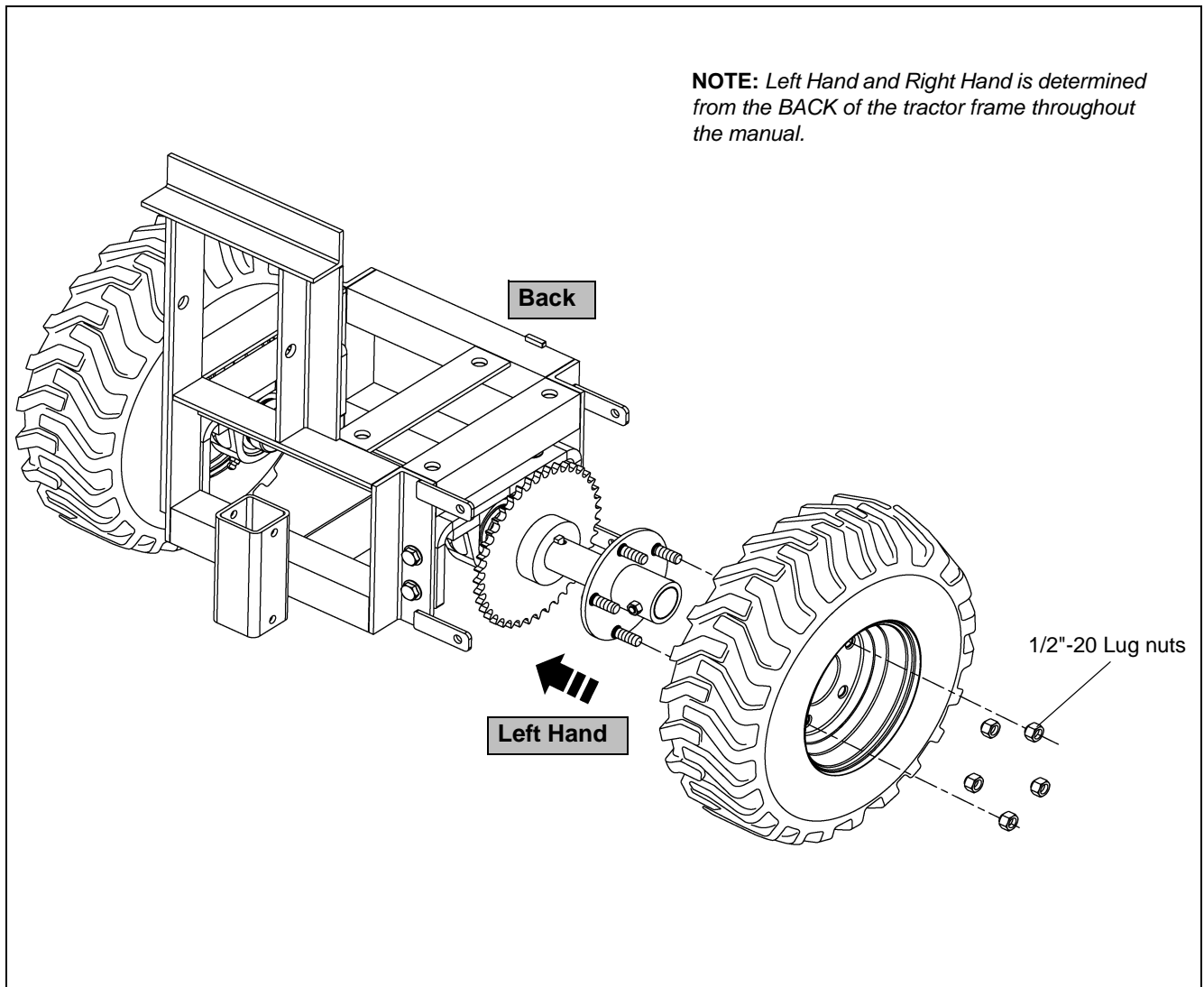

Figure 3C

8. Bolt the shield bracket weldment to the front of the tractor frame using two (2) 3/8"-16 x 3-1/2" hex head cap screws, two (2) 3/8" flat washers (only on the bottom slot of the weldment) and two (2) nuts.

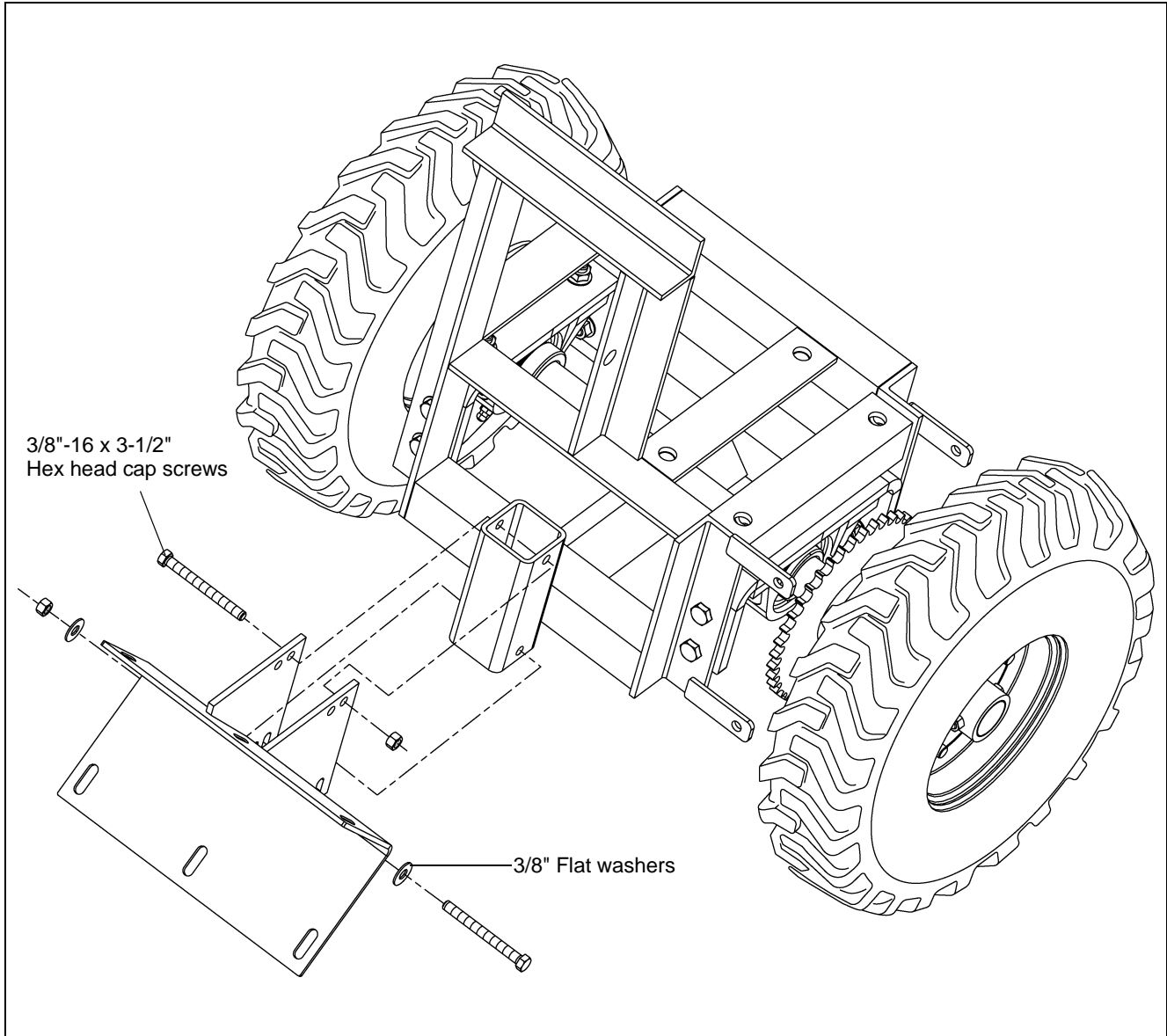
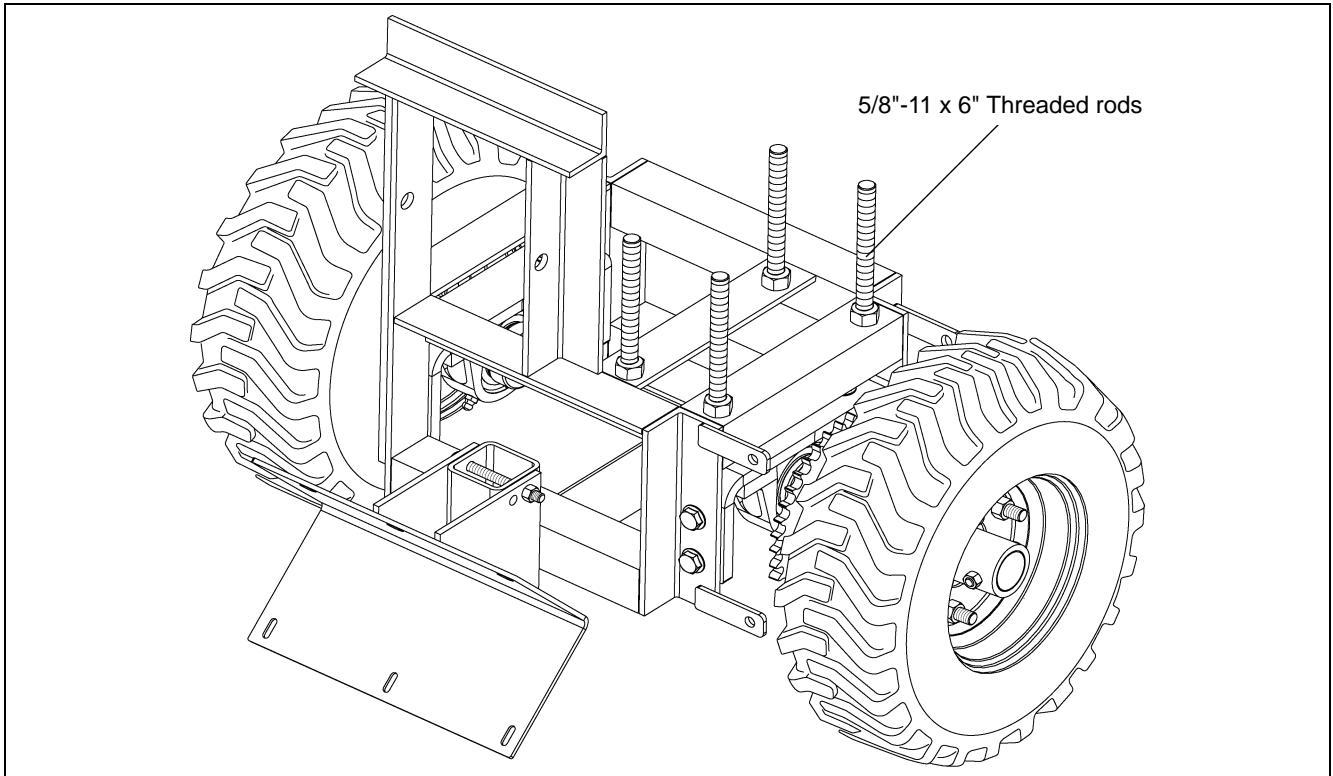

Figure 3D

### 3. Assembly

9. Bolt the four (4) 5/8"-11 x 6" threaded rods to the tractor frame using one (1) 5/8"-11 hex nut for each rod.



**Figure 3E**

10. Place one (1) 5/8"-11 hex nut onto each rod in a temporary position. These will hold the motor plate in place.

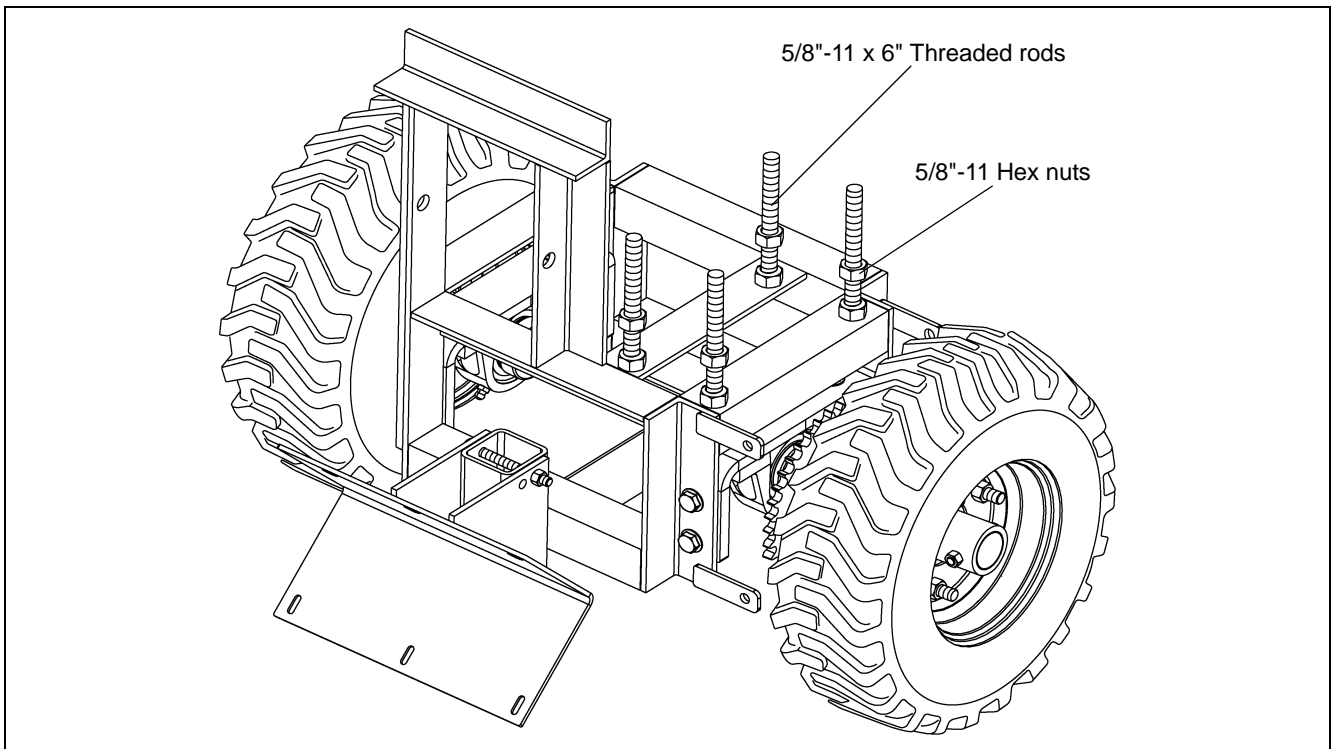

**Figure 3F**



11. Mount the motor to the gear box plate using four (4) 3/8"-16 x 1" flanged bolts, then place over the threaded rods, resting on the hex nuts.

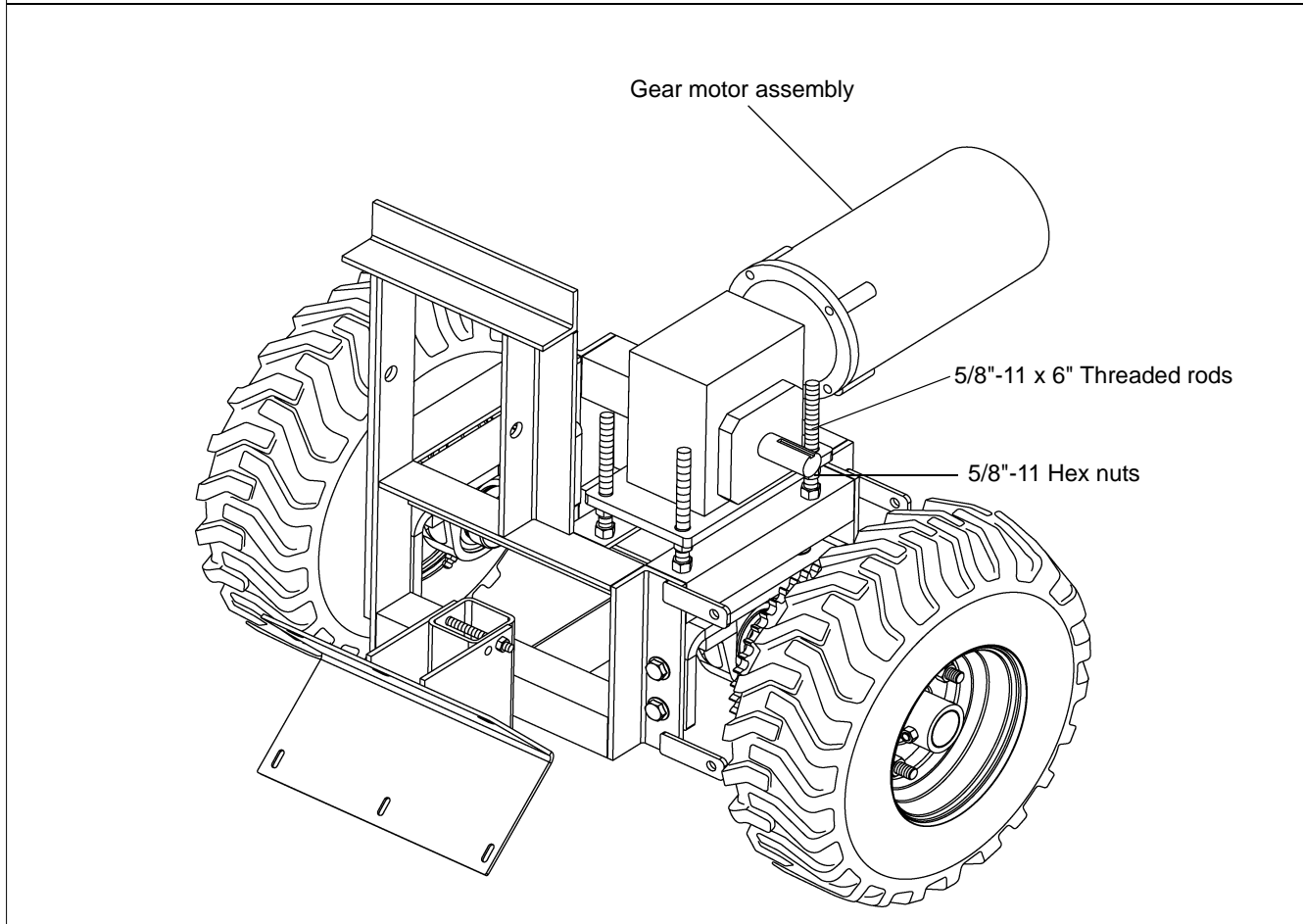
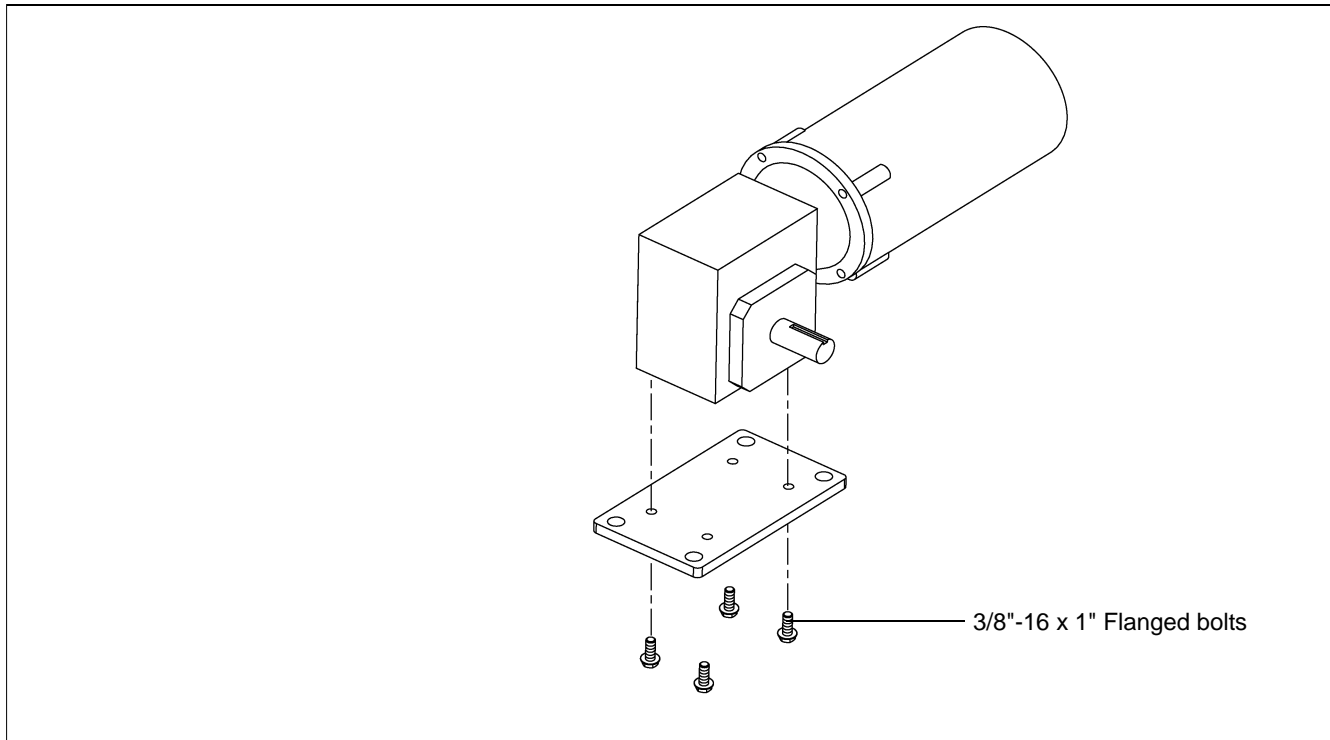

Figure 3G



13. Assemble the 13 tooth sprocket to the motor shaft using square key (1/4" x 1" long).
14. Install the roller chain around the sprockets. Adjust the position of the tractor axle (shaft) if necessary so as to align the chain correctly. Tighten the chain as required by adjusting the nuts on the 5/8"-11 x 6" threaded rod.

**NOTE:** *Tighten bearing lock collar.*

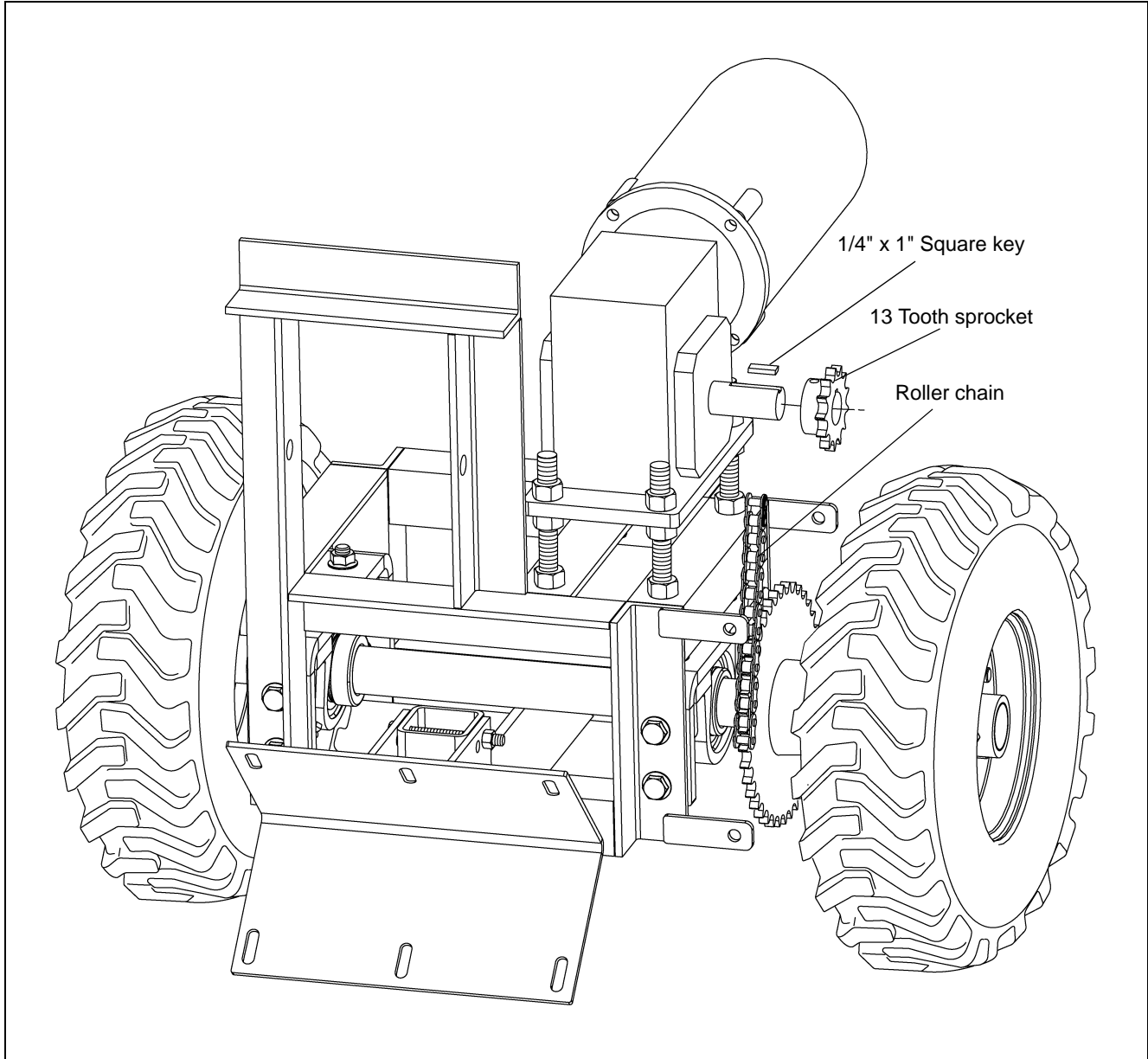

Figure 3I

### 3. Assembly

15. Install the top chain guard assembly to the tractor frame using four (4) hex bolts. Slide the bottom chain guard assembly through the slot on the top chain guard and secure tightly using 3/8"-16 x 3/4" flanged bolt.

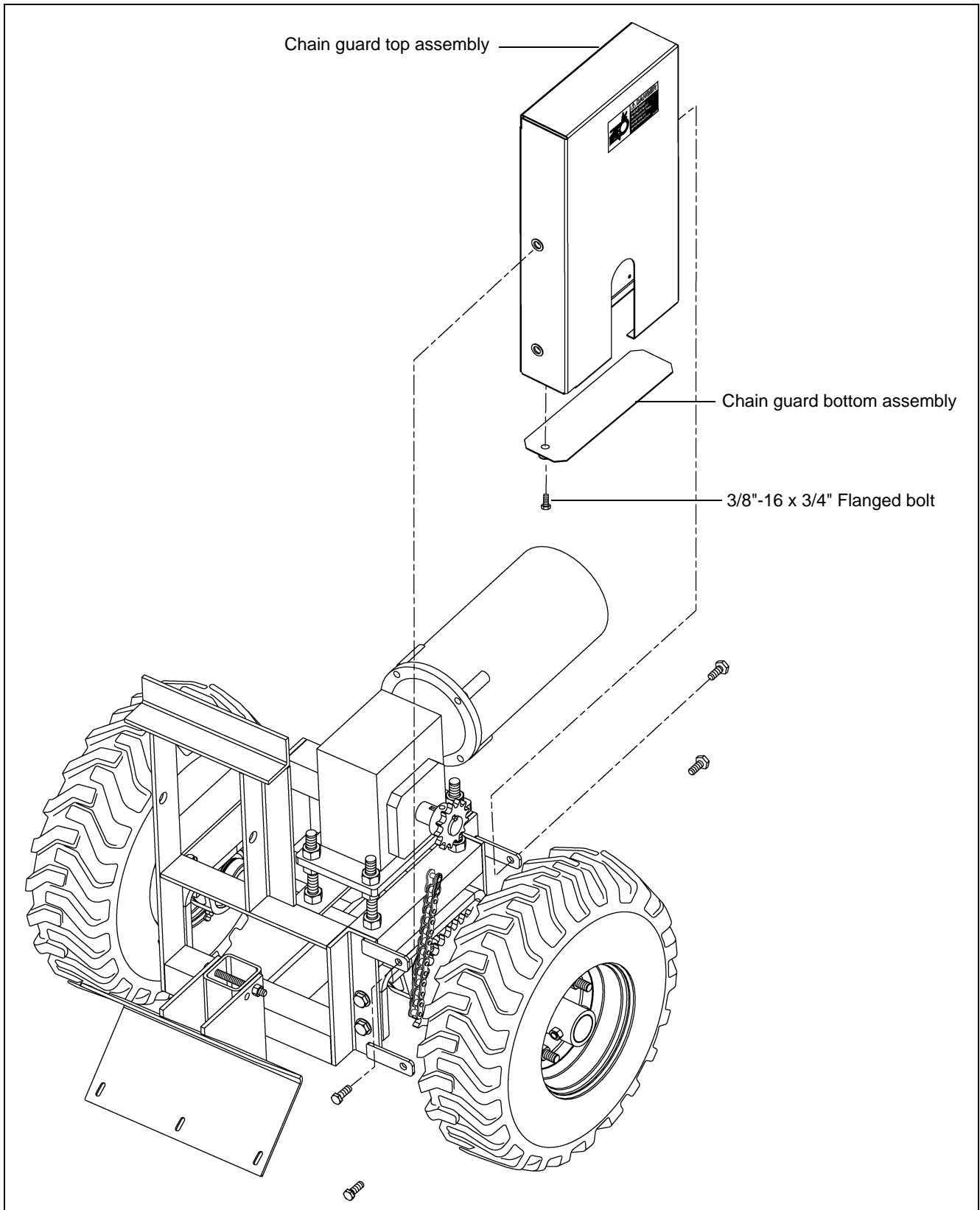

Figure 3J

16. Mount the weights to the tractor frame using one (1) 5/8"-11 x 8-1/2" threaded rod and three (3) flanged nuts and one (1) 5/8" flat washer.

**NOTE:** Install the weights against the left hand frame upright so the weight is in the middle of the tractor assembly.

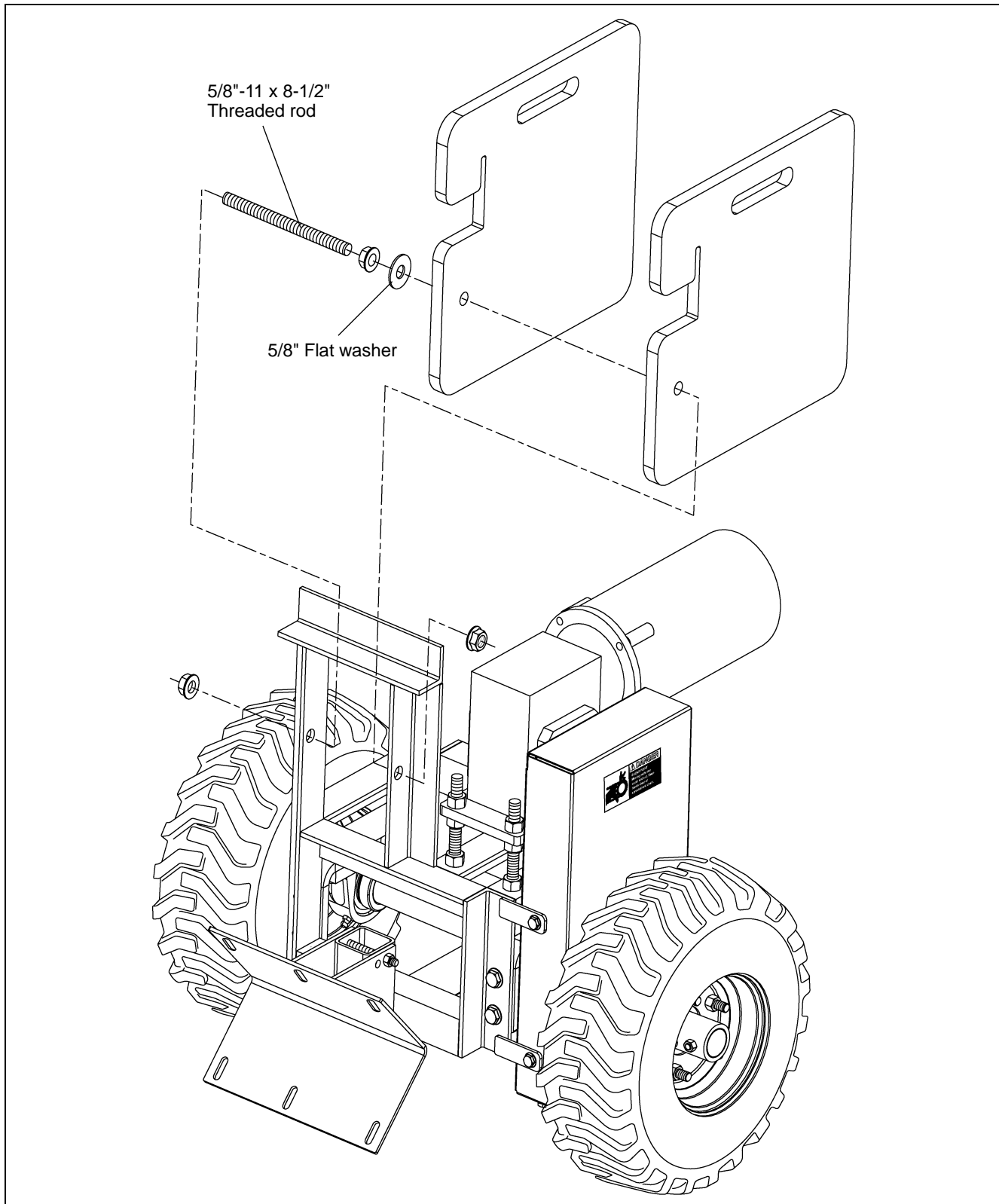

Figure 3K

### 3. Assembly

## End Wheel Assembly

**NOTE:** *If installing sweep tractor to an existing sweep, the current end wheel components must be removed.*

1. Connect stub into flighting using a 5/8" x 4" long hex head cap screw and 5/8" nylon lock nut.
2. Install bearing stand onto the stub shaft and bolt it to the sweep shield using a 3/8" x 3" hex head cap screw, a 3/8" x 3" long carriage bolt, flat washers, and nylon lock nuts.
3. Install the end wheel and collar onto the end of the stub shaft. Lock the collar in place with a 1/2" x 3-1/2" long hex head cap screw and 1/2" nylon lock nut.

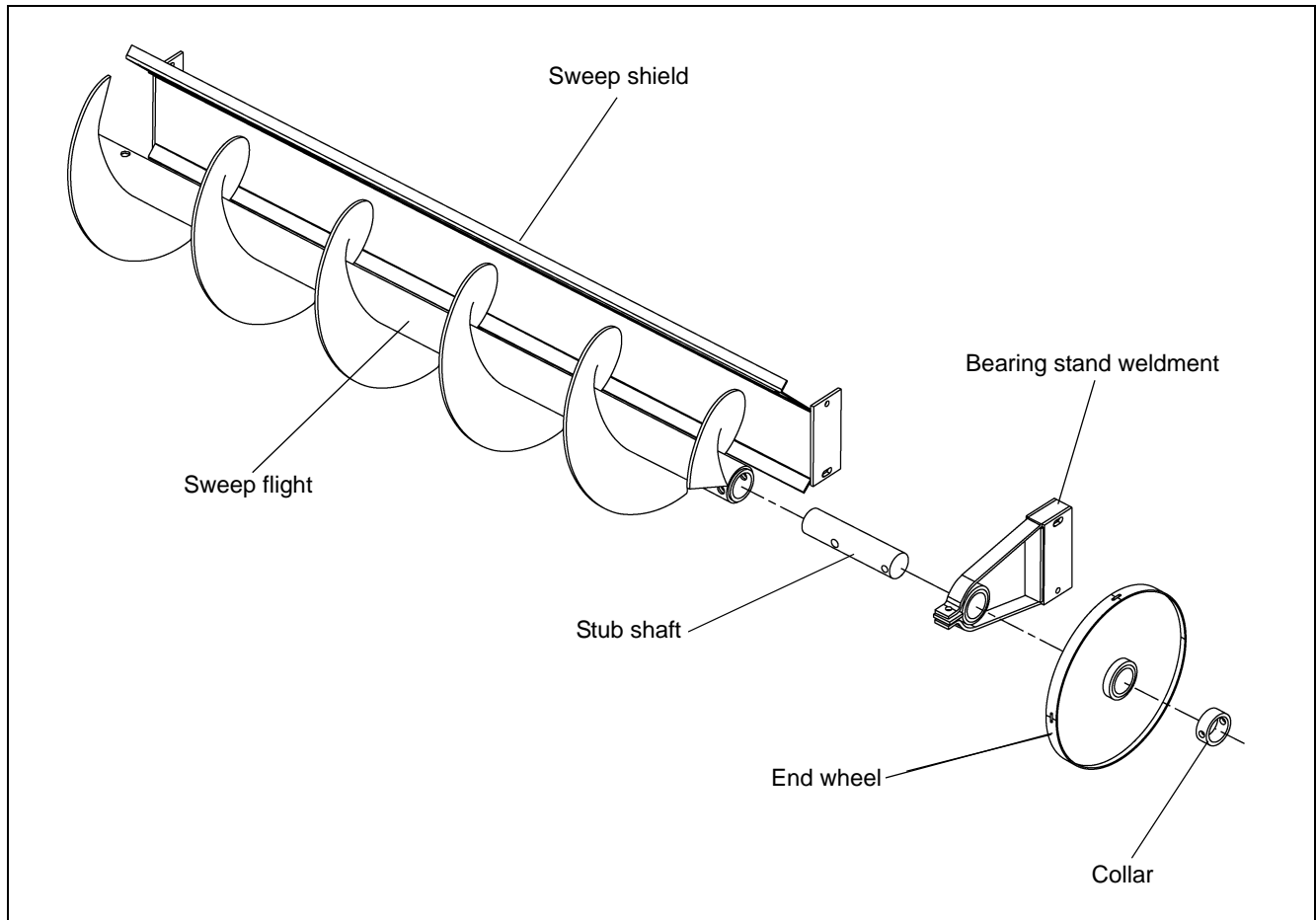

**Figure 3L** *End Wheel Assembly*

## Sweep Tractor to Shield Assembly

1. Position sweep tractor against the sweep shield approximately 3' from the end wheel.
2. Use the bracket on the sweep tractor to mark the location where the holes need to be drilled into the sweep shield. You may need to adjust the bolts on the sweep tractor bracket to match the same height and angle on the sweep shield.
3. After marking the hole location, drill six (6) 7/16" holes and then attach the sweep tractor to shield using six (6) 3/8" x 1" hex head cap screws, six (6) flat washers, and six (6) 3/8" nylon lock nuts.
4. Install electric wiring for motor and controls.



**All electrical wiring shall be installed by a qualified electrician and must meet the standards set by the National Electric Code and all local and state codes.**

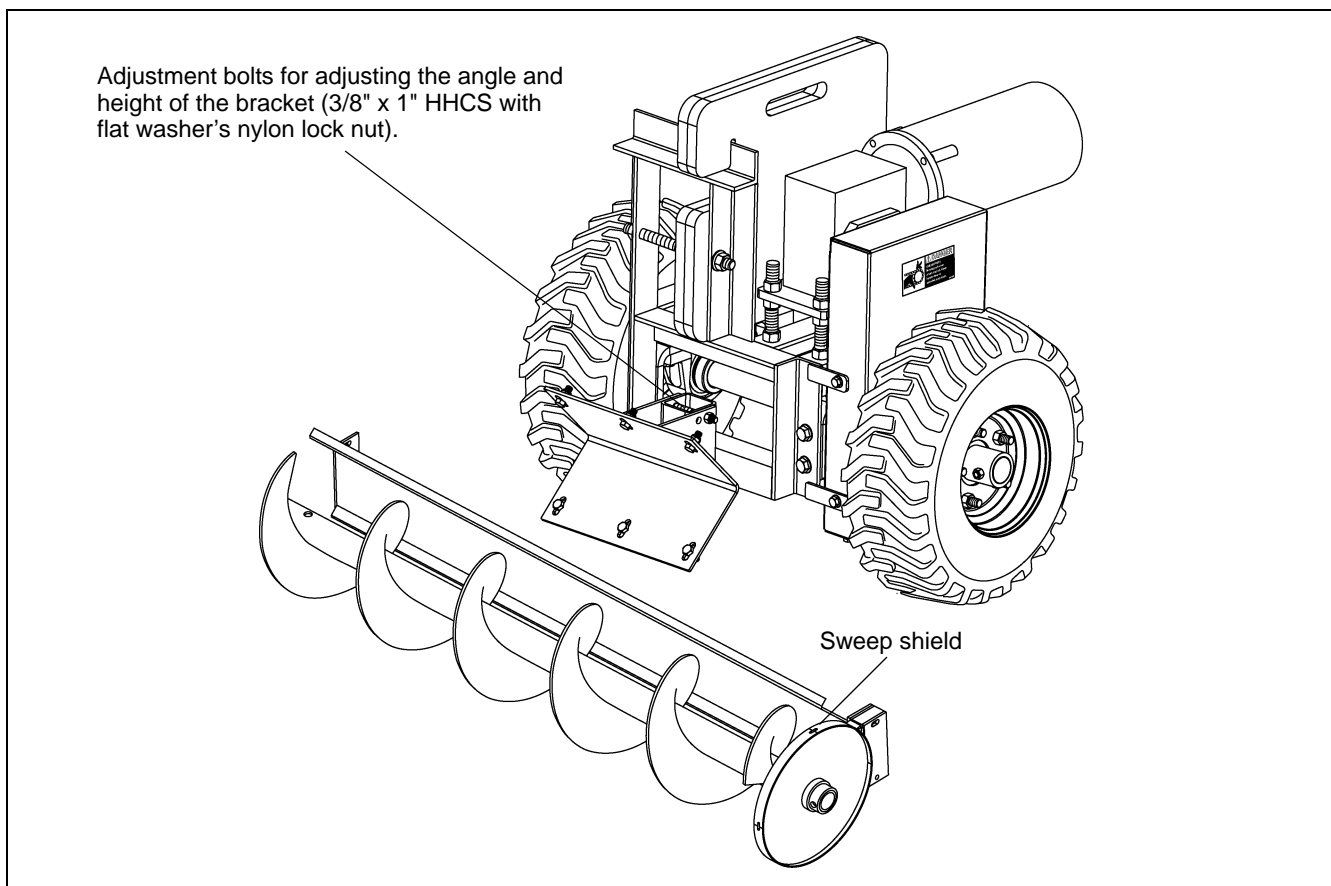

**Figure 3M** Shield to Tractor Assembly

# Sweep Tractor Parts

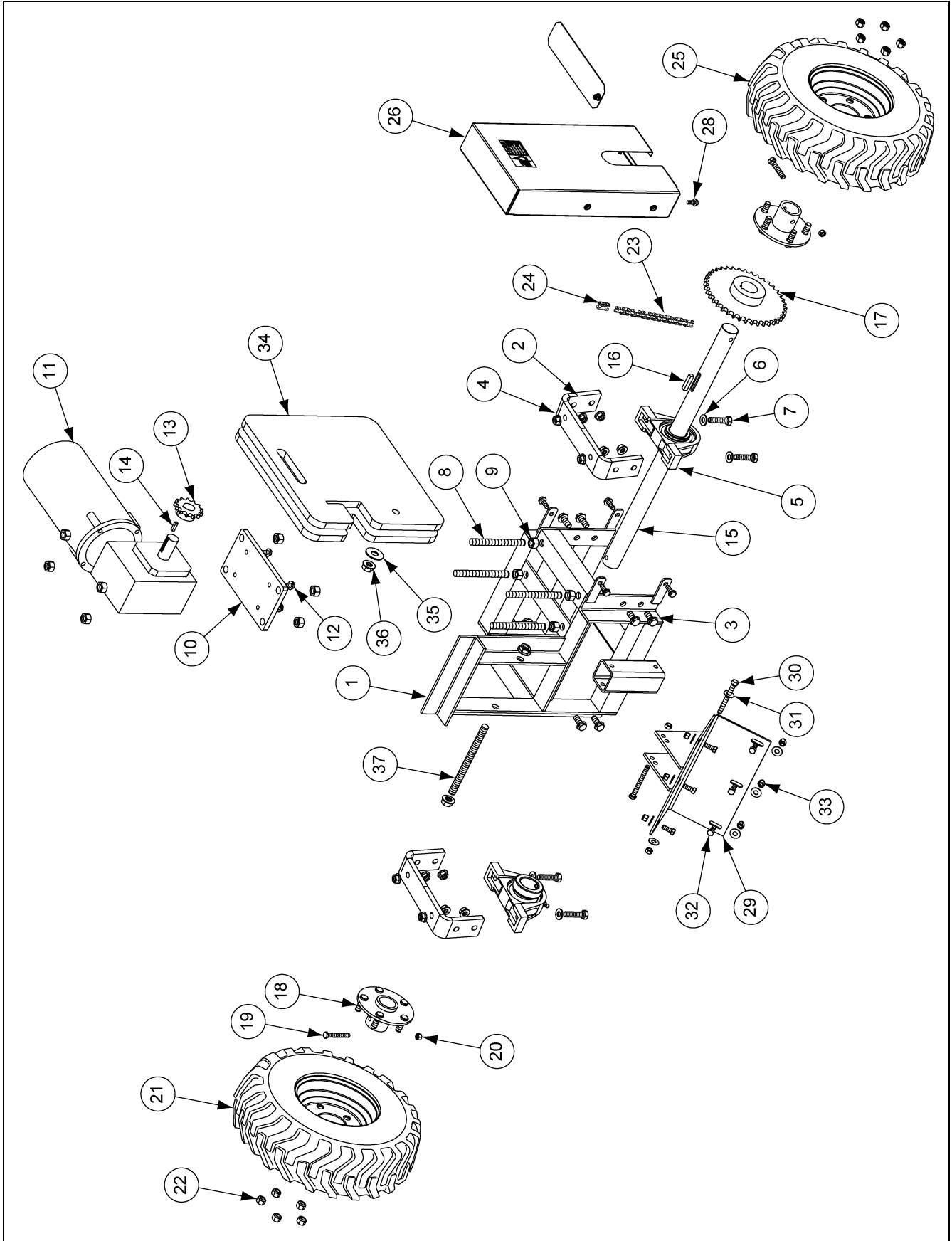



## Sweep Tractor Parts (Continued)

### 12" Tractor Drive Parts List

Ref #	Part #	Description
1	GK7714	Tractor Frame Weld
2	GK7716	Bearing Mounting Bracket
3	S-9062	Bolt Flange 1/2"-13 x 1-1/4" Zn Grade 5
4	S-8506	Serrated Flange Nut 1/2"-13 Zn
5	017-1486-4	Bearing: 1-5/8" Bore Pillow Block
6	S-2120	Washer Flat 1/2" SAE Zn
7	S-7811	Bolt HHCS 1/2"-13 x 2" Zn Grade 5
8	GC03552	Rod, Threaded 5/8"-11 x 6" Long
9	S-4110	Nut Hex 5/8"-11 Zn Grade 5
10	GK7719	Gear Box Plate
11	GK5481	Gear Motor Assembly (0.5 HP, 3 PH, TEFC) 208-230/460V
	GK6387	Gear Motor Assembly (0.5 HP, 3 PH, EXPF) 208-230/460V
	GK4985	Gear Motor Assembly (0.5 HP, 1 PH, TEFC) 208-230/460V
	GK7828	Gear Motor Assembly (0.5 HP, 1 PH, EXPF) 115/208-230V
	GK6827	Gear Motor Assembly (0.5 HP, 3 PH, TEFC) 380V
	GK7720	Gear Motor Assembly (0.5 HP, 3 PH, TEFC) 575V
12	S-9065	Bolt Flange 3/8"-16 x 1 Zn Grade 5
13	GK4978	Sprocket #50 13 Tooth 1-1/8" Bore Type B Hub
14	S-9168	Key Square 1/4" x 1"
15	GK7715	Tractor Axle
16	S-9179	Key Square 3/8" x 1-3/4"
17	GK7724	Sprocket #50 40 Tooth 1-5/8" Bore Type B Hub
18	GK7718	Wheel Hub
19	S-6762	Bolt Hex 3/8"-16 x 2-1/2" Zn Grade 5
20	S-8251	Nut Stover 3/8"-16 Zn Grade C
21	GK7749	Tire/Wheel: 4.80-8 5-Lug Tractor Bar Rt. Foam Filled
22	S-2698	Nut Lug 1/2"-20 Grade 5
23	GK7883	Roller Chain #50
24	D32-0015	Roller Chain #50 Connection Link
25	GK7748	Tire/Wheel: 4.80-8 5-Lug Tractor Bar Lt. Foam Filled
26	GK7712	Chain Guard Top Assembly
27	GK7713	Chain Guard Bottom Assembly
28	S-9067	Bolt Flanges 3/8"-16 x 3/4" Zn Grade 5
29	GK4975	Shield Bracket Weldment
30	S-8676	Bolt HHCS 3/8"-16 x 3-1/2" Zn Grade 5
31	S-248	Washer Flat 3/8" 7/16" I.D. 1" O.D. YDP
32	S-7469	Bolt HHCS 3/8"-16 x 1 Zn Grade 5
33	S-7383	Nut Nylock 3/8"-16 Zn Grade 5
34	GK7717	50 lbs. Tractor Weight
35	S-858	Washer Flat 5/8" USS Zn
36	S-9259	Nut Flange Whiz 5/8"-11 Zn
37	GK7725	Rod, Threaded 5/8"-11 x 8.5" Long

## End Wheel Parts

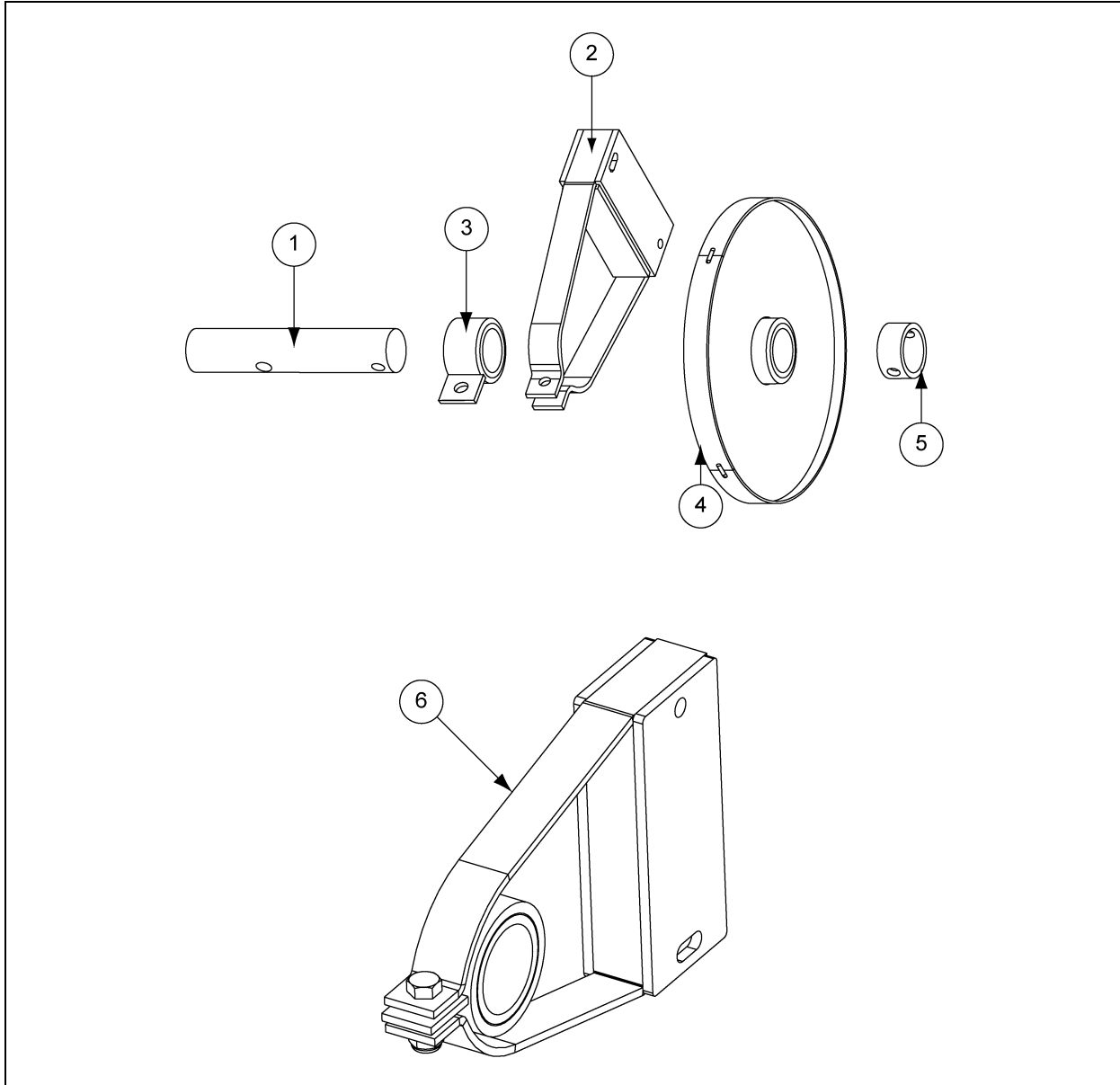

**Sweep Tractor End Wheel Parts List**

Ref #	Part #	Description
1	GK4952	Sweep Tractor End Wheel
2	GK2172	Bearing Bracket - 12"
3	GK2163	Bearing Holder W/2" Bronze Bush - 12"
4	GK6457	End Wheel Assembly - 10"
	GK4954	End Wheel Assembly - 12"
5	GK4951	Stub Collar
6	GK2047	Bearing Stand Assembly - 10"

## The GSI Group Warranty

THE GSI GROUP (GSI) WARRANTS ALL PRODUCTS WHICH IT MANUFACTURES TO BE FREE OF DEFECTS IN MATERIAL AND WORKMANSHIP UNDER NORMAL USAGE AND CONDITIONS FOR A PERIOD OF 12 MONTHS AFTER RETAIL SALE TO THE ORIGINAL END USER. THE PURCHASER'S SOLE REMEDY AND GSI'S ONLY OBLIGATION SHALL BE TO REPAIR OR REPLACE, AT GSI'S OPTION AND EXPENSE, PRODUCTS THAT, IN GSI'S SOLE JUDGMENT, CONTAIN A MATERIAL DEFECT DUE TO MATERIALS OR WORKMANSHIP. ALL DELIVERY AND SHIPMENT CHARGES TO AND FROM GSI'S FACTORY WILL BE PURCHASER'S RESPONSIBILITY. EXPENSES INCURRED BY OR ON BEHALF OF THE PURCHASER WITHOUT PRIOR WRITTEN AUTHORIZATION FROM AN AUTHORIZED EMPLOYEE OF GSI SHALL BE THE SOLE RESPONSIBILITY OF THE PURCHASER.

EXCEPT FOR THE LIMITED WARRANTY EXPRESSED ABOVE, GSI MAKES NO FURTHER WARRANTY OF ANY KIND, EXPRESS OR IMPLIED, INCLUDING, WITHOUT LIMITATION, WARRANTIES OF MERCHANTABILITY OR FITNESS FOR A PARTICULAR PURPOSE OR USE IN CONNECTION WITH (I) PRODUCT MANUFACTURED OR SOLD BY GSI OR (II) ANY ADVICE, INSTRUCTION, RECOMMENDATION OR SUGGESTION PROVIDED BY AN AGENT, REPRESENTATIVE OR EMPLOYEE OF GSI REGARDING OR RELATED TO THE CONFIGURATION, INSTALLATION, LAYOUT, SUITABILITY FOR A PARTICULAR PURPOSE, OR DESIGN OF SUCH PRODUCTS.

GSI SHALL NOT BE LIABLE FOR ANY DIRECT, INDIRECT, INCIDENTAL OR CONSEQUENTIAL DAMAGES, INCLUDING, WITHOUT LIMITATION, LOSS OF ANTICIPATED PROFITS OR BENEFITS. PURCHASER'S SOLE AND EXCLUSIVE REMEDY IS AS SET FORTH IN THE LIMITED WARRANTY EXPRESSED ABOVE, WHICH SHALL NOT EXCEED THE AMOUNT PAID FOR THE PRODUCT PURCHASED. THIS WARRANTY IS NOT TRANSFERABLE AND APPLIES ONLY TO THE ORIGINAL PURCHASER. GSI SHALL HAVE NO OBLIGATION OR RESPONSIBILITY FOR ANY REPRESENTATIONS OR WARRANTIES MADE BY OR ON BEHALF OF ANY DEALER, AGENT OR DISTRIBUTOR OF GSI.

GSI ASSUMES NO RESPONSIBILITY FOR CLAIMS RESULTING FROM ERECTION DEFECTS OR UNAUTHORIZED MODIFICATIONS TO PRODUCTS WHICH IT MANUFACTURED. MODIFICATIONS TO PRODUCTS NOT SPECIFICALLY DELINEATED IN THE MANUAL ACCOMPANYING THE EQUIPMENT AT INITIAL SALE WILL NULLIFY THE PRODUCT WARRANTY THAT MIGHT HAVE BEEN OTHERWISE AVAILABLE.

THE FOREGOING WARRANTY SHALL NOT EXTEND TO PRODUCTS OR PARTS WHICH HAVE BEEN DAMAGED BY NEGLIGENT USE, MISUSE, ALTERATION OR ACCIDENT. THIS WARRANTY EXTENDS SOLELY TO ONLY PRODUCTS MANUFACTURED BY GSI. THIS WARRANTY IS EXCLUSIVE AND IN LIEU OF ALL OTHER WARRANTIES EXPRESS OR IMPLIED. GSI RESERVES THE RIGHT TO MAKE DESIGN OR SPECIFICATION CHANGES AT ANY TIME.

PRIOR TO INSTALLATION, PURCHASER HAS THE RESPONSIBILITY TO COMPLY WITH ALL FEDERAL, STATE AND LOCAL CODES WHICH MAY APPLY TO THE LOCATION AND INSTALLATION OF PRODUCTS MANUFACTURED OR SOLD BY GSI.

This equipment shall be installed in accordance with the current installation codes and applicable regulations which should be carefully followed in all cases. Authorities having jurisdiction should be consulted before installations are made.

G S I G R O U P



**GSI Group**  
**1004 E. Illinois St.**  
**Assumption, IL 62510-0020**  
**Phone: 1-217-226-4421**  
**Fax: 1-217-226-4420**  
**[www.gsiag.com](http://www.gsiag.com)**

Copyright © 2008 by GSI Group  
Printed in the USA

## Free Manuals Download Website

<http://myh66.com>

<http://usermanuals.us>

<http://www.somanuals.com>

<http://www.4manuals.cc>

<http://www.manual-lib.com>

<http://www.404manual.com>

<http://www.luxmanual.com>

<http://aubethermostatmanual.com>

Golf course search by state

<http://golfingnear.com>

Email search by domain

<http://emailbydomain.com>

Auto manuals search

<http://auto.somanuals.com>

TV manuals search

<http://tv.somanuals.com>