

Instructions—Parts List



HIGH PRESSURE

Fluid Regulators

306878Y

EN

For use in airless spray systems to control and regulate fluid pressure to one spray gun, dispensing valve, or atomizing head. For professional use only.

3000 psi (21 MPa, 207 bar) Maximum Working Pressure

Model 206661, Series G

1000–3000 psi (7–21 MPa, 70–207 bar)

Regulated Fluid Pressure Range

Model 217576, Series D

200–1000 psi (1.4–7 MPa, 14–70 bar)

Regulated Fluid Pressure Range



Important Safety Instructions

Read all warnings and instructions in this manual.
Save these instructions.

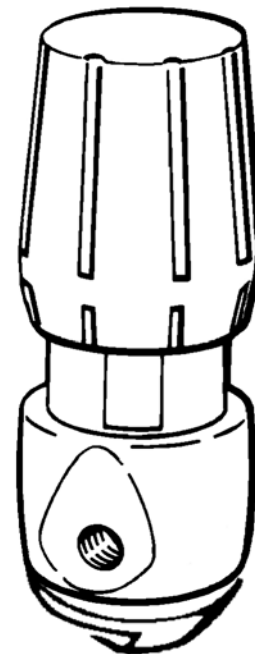

Table of Contents

Symbols	2
Warnings	2
Installation	4
Operation	7
Maintenance	8
Parts	9
Accessories	11
Technical Data	11
Warranty	12
Graco Information	12

PROVEN QUALITY. LEADING TECHNOLOGY.

Symbols

Warning Symbol



This symbol alerts you to the possibility of serious injury or death if you do not follow the instructions.

Caution Symbol



This symbol alerts you to the possibility of damage to or destruction of equipment if you do not follow the instructions.

WARNING



INSTRUCTIONS

EQUIPMENT MISUSE HAZARD

Equipment misuse can cause the equipment to rupture or malfunction and result in serious injury.

- This equipment is for professional use only.
- Read all instruction manuals, tags, and labels before operating the equipment.
- Use the equipment only for its intended purpose. If you are not sure, call your Graco distributor.
- Do not alter or modify this equipment.
- Check equipment daily. Repair or replace worn or damaged parts immediately.
- Do not exceed the maximum working pressure of the lowest rated system component. Refer to the **Technical Data** on page 11 for the maximum working pressure of this equipment.
- Use fluids and solvents which are compatible with the equipment wetted parts. Refer to the **Technical Data** section of all equipment manuals. Read the fluid and solvent manufacturer's warnings.
- Route hoses away from traffic areas, sharp edges, moving parts, and hot surfaces. Do not expose Graco hoses to temperatures above 180°F (82°C) or below -40°F (-40°C).
- Do not kink or over bend the hoses or use the hoses to pull equipment.
- Wear hearing protection when operating this equipment.
- Do not lift pressurized equipment.
- Comply with all applicable local, state, and national fire, electrical, and safety regulations.

WARNING



INJECTION HAZARD

Spray from the gun, leaks or ruptured components can inject fluid into your body and cause extremely serious injury, including the need for amputation. Fluid splashed in the eyes or on the skin can also cause serious injury.



- Fluid injected into the skin might look like just a cut, but it is a serious injury. **Get immediate surgical treatment.**
- Do not stop or deflect leaks with your hand, body, glove or rag.
- Keep your hands away from the end of the drain valve when opening it.
- Lock the gun trigger safety when you stop spraying.
- Follow the **Pressure Relief Procedure** on page 7 if the spray tip clogs and before cleaning, checking or servicing the equipment.
- Follow the **Pressure Relief Procedure** on page 7 before removing the regulator's adjusting knob.
- Do not pressurize the system when the fluid regulator's adjusting knob is removed.
- Tighten all fluid connections before operating the equipment.
- Check the hoses, tubes, and couplings daily. Replace worn or damaged parts immediately. Do not repair high pressure couplings; you must replace the entire hose.
- Use only Graco approved hoses. Do not remove the spring guard that is used to help protect the hose from rupture caused by kinks or bends near the couplings.



TOXIC FLUID HAZARD

Hazardous fluid or toxic fumes can cause serious injury or death if splashed in the eyes or on the skin, inhaled, or swallowed.

- Know the specific hazards of the fluid you are using.
- Store hazardous fluid in an approved container. Dispose of hazardous fluid according to all local, state and national guidelines.
- Always wear protective eyewear, gloves, clothing and respirator as recommended by the fluid and solvent manufacturer.

Installation

Fluid pressure regulators are used for accurate, positive control of the fluid pressure to spray guns, dispensing valves or atomizing heads.

Regulators installed at circulating line take-offs or pumps are used to reduce main line pressure and maintain the desired fluid pressure to the spray gun, dispensing valve, or atomizing head.

Before Installing the Fluid Regulator

1. Determine placement of the fluid regulator in system.
2. Install a ball valve for inlet and outlet of the regulator.
3. Install temporary plumbing between the ball valves.
4. Thoroughly flush the system to remove metal chips and other contaminants and to check for leaks.

Installing the Fluid Regulator

1. Remove the temporary plumbing and install one regulator for each spray gun. A mounting stud, washers, and locknut are provided for mounting the regulator either from the bottom or side.
2. Put sealer on threaded connections, except on swivel unions as it interferes with the swivel action.
3. Connect the fluid supply line to the 3/8 npt(f) inlet of the fluid regulator. Connect the fluid line between the gun and the regulator's 1/4 npt(f) outlet of choice. *MAKE SURE* that the direction of fluid flow agrees with the IN and OUT markings on the regulator body.
4. Flush and test the entire system.

Installation

Single Direct Spray Station

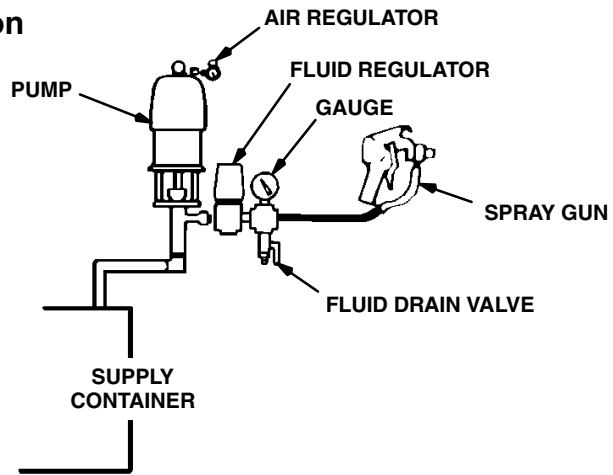

Fig 1

Multiple Circulating Spray Station

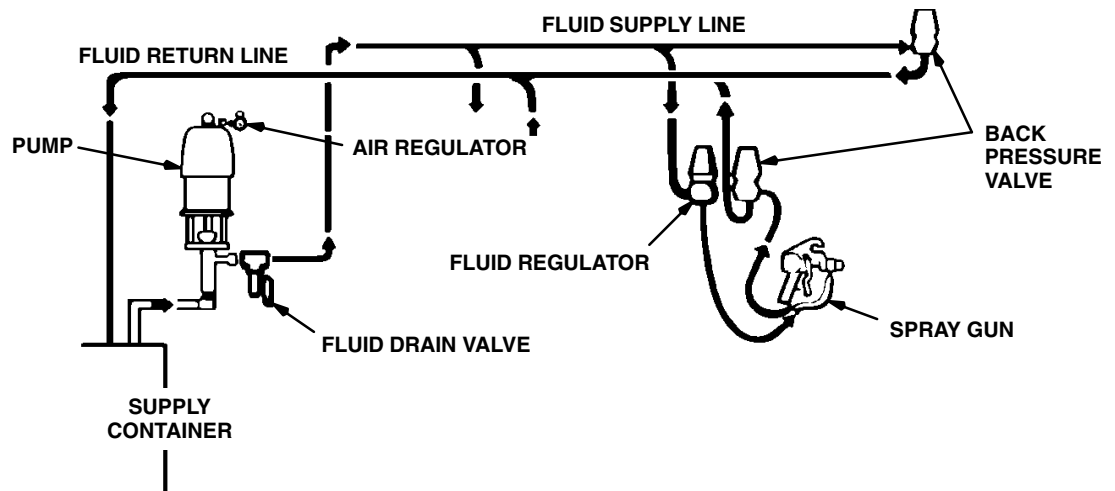
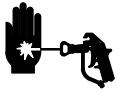

Fig 2

Operation

Pressure Relief Procedure

WARNING



INJECTION HAZARD

The system pressure must be manually relieved to prevent the system from starting or spraying accidentally. Fluid under high pressure can be injected through the skin and cause serious injury. To reduce the risk of an injury from injection, splashing fluid, or moving parts, follow the **Pressure Relief Procedure** whenever you:

- are instructed to relieve the pressure,
- stop spraying,
- check or service any of the system equipment,
- or install or clean the spray tip.

1. Lock the gun trigger safety.
2. Close the bleed-type master air valve (required in your system).
3. Unlock the gun trigger safety.
4. Hold a metal part of the gun firmly to the side of a grounded metal pail, and trigger the gun to relieve pressure.
5. Lock the gun trigger safety.

6. Open the drain valve (required in your system), having a container ready to catch the drainage.
7. Leave the drain valve open until you are ready to spray again.

*If you suspect that the spray tip or hose is completely clogged, or that pressure has not been fully relieved after following the steps above, **very slowly** loosen the tip guard retaining nut or hose end coupling and relieve pressure gradually, then loosen completely. Now clear the tip or hose.*

Adjusting the Regulator

The fluid pressure regulator controls pressure downstream from its outlet.

*To adjust the fluid regulator, first, back the knob out until there is no spring pressure. Then, turn the knob *clockwise* to increase pressure.*

NOTE: If you are using an accessory fluid pressure gauge, relieve the spray gun line when reducing pressure to ensure a correct gauge reading.

Adjust the pump air pressure and the fluid regulator for the best spraying combination. *In a circulating system, also adjust the back pressure valve.*

Record all the settings for future reference. The valve cylinder (7) has exterior markings (set points 1 to 8) for repeat settings.

Maintenance

WARNING

COMPONENT RUPTURE HAZARD

 To reduce the risk of serious bodily injury, including fluid injection or splashing in the eyes or on the skin, *always* follow the **Pressure Relief Procedure** on page 7 before adjusting, cleaning, repairing, or removing the regulator from the system.

Never pressurize the system with the fluid regulator adjusting knob removed.

Never completely remove the adjusting knob when system pressure is present.

Flushing

- Flush before changing colors, before fluid can dry in the equipment, at the end of the day, before storing, and before repairing equipment.
 - Flush at the lowest pressure possible. Check connectors for leaks and tighten as necessary.
 - Flush with a fluid that is compatible with the fluid being dispensed and the equipment wetted parts.
1. Record the pressure adjustment setting of the regulator before flushing.
 2. Shut off the pump and relieve fluid pressure in the system by triggering the gun and opening the back pressure valve or other bypass valve.
 3. Never exceed the maximum working pressure of the lowest rated system component.
 4. Open the fluid regulator by turning the adjusting knob (6) fully *clockwise*.
 5. Supply solvent to the system. Set pump to the lowest possible pressure, and start pump.
 6. Flush until thoroughly clean.
 7. Adjust the fluid regulator to return to the desired fluid pressure setting.

NOTE: Do not allow paint or solvent to set in the system for a long time. Fluid could dry on the piston, causing leakage at the piston packing. If leakage occurs, disassemble and clean the regulator.

Cleaning

When changing fluids or colors, the regulator should be disassembled and cleaned. Regular cleaning and inspection, and lubrication of the piston (15) and piston packing (10) are necessary to keep the fluid regulator working properly.

1. Relieve all the air and fluid pressure in the system.
2. Remove the regulator from the system.
3. Disassemble the regulator, referring to the **Parts Drawing** on page 9. Clean and inspect all parts.

CAUTION

Use special care when handling the hard carbide portions of the piston (13) and seat (12). Damage will cause poor operation and leakage.

Repairing

Normally, only the ball support (21), seat (20) and piston packing (10) will ever need replacement. Repair Kit 220139 is available to replace these parts. See page 9.

1. Lubricate the piston packing (10), piston (15), and spring locater (11) with lithium base grease.
2. Place the washer (19) over the pointed end of the piston (15).
3. Place the packing (10), with its lips facing down, over the pointed end of the piston (15) and against the washer (19).
4. Insert the piston (15) into the bottom of the cylinder (7) and gently work it into place.
5. Reassemble the remaining parts in reverse order of disassembly. Torque the valve seat (20) into the housing to 175 to 200 in-lb (20 to 22 N•m). Over tightening could break off the hex portion of the seat.

Parts

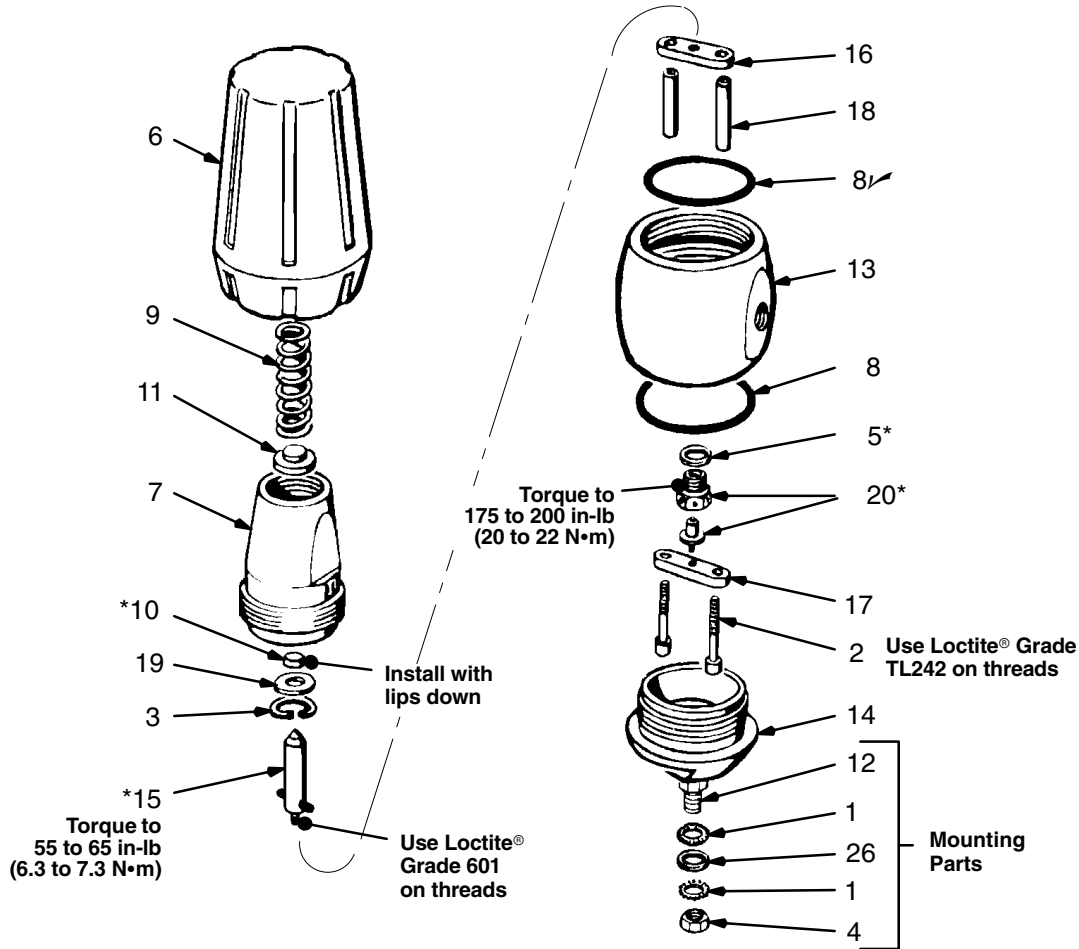

Model 206661, Series G

Includes items 1–20

REF NO.	PART NO.	DESCRIPTION	QTY
1	100322	LOCK WASHER, ext shkprf; 7/16" 2 (Model 206661 only)	2
	100639	LOCK WASHER, ext shkprf; 3/8" 2 (Model 217576 only)	2
2	101885	SCREW, soc hd cap; 1/4–20 x 1–3/4"	2
3	101954	RING, int retaining; 0.75" (19 mm) 1 housing dia.; cadmium plated	1
4	150513	NUT, jam; 7/16–20 1 (Model 206661 only)	1
	100307	NUT, jam; 3/8–16 1 (Model 217576 only)	1
5	150670*	GASKET; copper 1	1
6	166976	KNOB, adjusting 1	1
7	166982	CYLINDER, regulator 1	1
8	166985✓	SEAL, o-ring; PTFE 2	2
9	166986	SPRING, helical compression 1 (Model 206661 only)	1
	501511	SPRING, helical compression 1 (Model 217576 only)	1
10	111796*	PACKING, u-type; PTFE 1	1

Model 217576, Series D

Includes items 1–26

REF NO.	PART NO.	DESCRIPTION	QTY
11	166988	LOCATER, spring 1	1
12	167001	STUD, mounting; 1/4 npt; 7/16–20 1 (Model 206661 only)	1
	156953	STUD, mounting; 1/4 npt; 3/8–16 1 (Model 217576 only)	1
13	177125	HOUSING, regulator 1	1
14	167016	CAP, end 1	1
15	220900*	PISTON, valve 1	1
16	167018	BAR, piston 1	1
17	167019	BAR, valve ball support 1	1
18	167020	SPACER, bar 2	2
19	171885	WASHER, back-up; acetal 1 homopolymer	1
20	248899*	SEAT, valve, support ball 1	1
26	100023	WASHER; 3/8" 1 (Model 217576 only)	1

* These parts are included in Repair Kit 220139, which may be purchased separately.

✓ Keep these spare parts on hand to reduce down time.

Accessories

Use Only Genuine Graco Parts and Accessories

Fluid Pressure Gauges

Attaches to optional regulator outlet.
2 in. (51 mm) dial.

- 102397** 0–3000 psi (0–21 MPa, 0–207 bar)
1/4 npt(m) center back fitting
- 101696** 0–1000 psi (0–7 MPa, 0–70 bar)
1/4 npt(m) bottom fitting

UHMW Polyethylene U-Type Packing 108317 (included in Repair Kit 220135)

Use instead of 111796 (ref. no. 10), with abrasive fluids.

Fluid Regulator Conversion Kit 915643

Air-operated fluid regulator conversion kit for high-pressure regulator 206661.

Compression Springs

NOTE: On Model 206661, standard spring 166986 (ref. no. 9) works best at 2000–3000 psi (13.5–21 MPa, 135–207 bar), although it will work at 1000 to 2000 psi (7–13.5 MPa, 70–135 bar). For best results at pressures less than 2000 psi (13.5 MPa, 135 bar), order the following applicable spring.

- 501510** Recommended for 1000–2000 psi (7–13.5 MPa, 70–135 bar). Red color.
- 501511** Recommended for 0–1000 psi (0–7 MPa, 0–70 bar) range. Blue color. (Standard on model 217576)

Optional Valve Seat 206523

For use in low flow rate applications.

Technical Data

Category	Data
Maximum Fluid Inlet Pressure	3000 psi (21 MPa, 207 bar)
Regulated Fluid Pressure Range	<i>Models 206661:</i> 1000–3000 psi (7–21 MPa, 70–207 bar) <i>Model 217576:</i> 200–1000 psi (1.4–7 MPa, 14–70 bar)
Maximum Flow Rate	3.5 gpm (13.25 liters/min) with 70 centipoise fluid at 75°F (23°C)
Fluid Inlet	3/8 npt(f)
Fluid Outlet (two)	1/4 npt(f)
Height	6 in. (152 mm)
Diameter	2.687 in. (68 mm)
Wetted Parts	Tungsten Carbide, Copper, Cadmium and Zinc-plated Steels, Acetal Homopolymer, PTFE, Chrome-plated Stainless Steel
Canadian Registration Number (CRN): Alberta – 0C04874.52 Ontario – 0C4874.5R1	<i>Models 206661 and 217576</i>

Graco Standard Warranty

Graco warrants all equipment manufactured by Graco and bearing its name to be free from defects in material and workmanship on the date of sale by an authorized Graco distributor to the original purchaser for use. With the exception of any special, extended, or limited warranty published by Graco, Graco will, for a period of twelve months from the date of sale, repair or replace any part of the equipment determined by Graco to be defective. This warranty applies only when the equipment is installed, operated and maintained in accordance with Graco's written recommendations.

This warranty does not cover, and Graco shall not be liable for general wear and tear, or any malfunction, damage or wear caused by faulty installation, misapplication, abrasion, corrosion, inadequate or improper maintenance, negligence, accident, tampering, or substitution of non-Graco component parts. Nor shall Graco be liable for malfunction, damage or wear caused by the incompatibility of Graco equipment with structures, accessories, equipment or materials not supplied by Graco, or the improper design, manufacture, installation, operation or maintenance of structures, accessories, equipment or materials not supplied by Graco.

This warranty is conditioned upon the prepaid return of the equipment claimed to be defective to an authorized Graco distributor for verification of the claimed defect. If the claimed defect is verified, Graco will repair or replace free of charge any defective parts. The equipment will be returned to the original purchaser transportation prepaid. If inspection of the equipment does not disclose any defect in material or workmanship, repairs will be made at a reasonable charge, which charges may include the costs of parts, labor, and transportation.

THIS WARRANTY IS EXCLUSIVE, AND IS IN LIEU OF ANY OTHER WARRANTIES, EXPRESS OR IMPLIED, INCLUDING BUT NOT LIMITED TO WARRANTY OF MERCHANTABILITY OR WARRANTY OF FITNESS FOR A PARTICULAR PURPOSE.

Graco's sole obligation and buyer's sole remedy for any breach of warranty shall be as set forth above. The buyer agrees that no other remedy (including, but not limited to, incidental or consequential damages for lost profits, lost sales, injury to person or property, or any other incidental or consequential loss) shall be available. Any action for breach of warranty must be brought within two (2) years of the date of sale.

Graco makes no warranty, and disclaims all implied warranties of merchantability and fitness for a particular purpose in connection with accessories, equipment, materials or components sold but not manufactured by Graco. These items sold, but not manufactured by Graco (such as electric motors, switches, hose, etc.), are subject to the warranty, if any, of their manufacturer. Graco will provide purchaser with reasonable assistance in making any claim for breach of these warranties.

In no event will Graco be liable for indirect, incidental, special or consequential damages resulting from Graco supplying equipment hereunder, or the furnishing, performance, or use of any products or other goods sold hereto, whether due to a breach of contract, breach of warranty, the negligence of Graco, or otherwise.

FOR GRACO CANADA CUSTOMERS

The parties acknowledge that they have required that the present document, as well as all documents, notices and legal proceedings entered into, given or instituted pursuant hereto or relating directly or indirectly hereto, be drawn up in English. Les parties reconnaissent avoir convenu que la rédaction du présente document sera en Anglais, ainsi que tous documents, avis et procédures judiciaires exécutés, donnés ou intentés à la suite de ou en rapport, directement ou indirectement, avec les procédures concernées.

Graco Information

For the latest information about Graco products, visit www.graco.com.

TO PLACE AN ORDER, contact your Graco distributor or call to identify the distributor closest to you:

Phone: 612-623-6921 or **Toll Free:** 1-800-328-0211 **Fax:** 612-378-3505

All written and visual data contained in this document reflects the latest product information available at the time of publication.

Graco reserves the right to make changes at any time without notice.

Original instructions. This manual contains English. MM 306878

Graco Headquarters: Minneapolis

International Offices: Belgium, China, Japan, Korea

GRACO INC. AND SUBSIDIARIES • P.O. BOX 1441 • MINNEAPOLIS MN 55440-1441 • USA
Copyright 1992, Graco Inc. All Graco manufacturing locations are registered to ISO 9001.

www.graco.com

Revision Y, April 2015

Free Manuals Download Website

<http://myh66.com>

<http://usermanuals.us>

<http://www.somanuals.com>

<http://www.4manuals.cc>

<http://www.manual-lib.com>

<http://www.404manual.com>

<http://www.luxmanual.com>

<http://aubethermostatmanual.com>

Golf course search by state

<http://golfingnear.com>

Email search by domain

<http://emailbydomain.com>

Auto manuals search

<http://auto.somanuals.com>

TV manuals search

<http://tv.somanuals.com>