

BARNES®

INSTALLATION and OPERATION MANUAL Submersible Non-Clog Pump

Explosion Proof, Class I, Groups C & D, Division 1

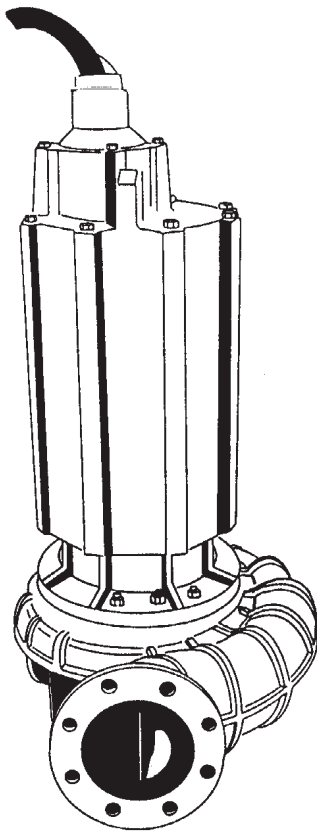

Series: 8XSE-HA
20 - 30HP, 870RPM, 60Hz
30 - 75HP, 1150RPM, 60Hz
100 - 150HP, 1750RPM, 60Hz

IMPORTANT!

Read all instructions in this manual before operating pump.

As a result of Crane Pumps & Systems, Inc., constant product improvement program, product changes may occur. As such Crane Pumps & Systems reserves the right to change product without prior written notification.

CRANE[®]

A Crane Co. Company

PUMPS & SYSTEMS

420 Third Street
Piqua, Ohio 45356
Phone: (937) 778-8947
Fax: (937) 773-7157
www.cranepumps.com

83 West Drive, Bramton
Ontario, Canada L6T 2J6
Phone: (905) 457-6223
Fax: (905) 457-2650



Form No. 084841-Rev. H

TABLE OF CONTENTS

SAFETY FIRST	3
A. PUMP SPECIFICATIONS	4
B. GENERAL INFORMATION	5
C. INSTALLATION	5 - 8
ELECTRICAL DATA	7
D. START-UP OPERATION	8 - 10
E. PREVENTATIVE MAINTENANCE	10
F. SERVICE and REPAIR	10 - 11
G. REPLACEMENT PARTS.....	11
TROUBLE SHOOTING	12
CROSS-SECTION, (Fig. 7).....	13
EXPLODED VIEW, (Fig. 8)	14
PARTS LIST	15 - 16
RETURNED GOODS POLICY.....	17
WARRANTY	18
START-UP REPORT	21 - 22
WARRANTY REGISTRATION	
SPECIAL TOOLS AND EQUIPMENT	
INSULATION TESTER (MEGGER)	

Other brand and product names are trademarks or registered trademarks of their respective holders.

® WARRICK Controls is a registered trademark of Charles F. WARRICK Co.

® Reliance is a registered trademark of Rockwell Automation

® Barnes is a registered trademark of Crane Pumps & Systems, Inc

1996, 1997, 1998, 2002, 01/04, 3/06, 9/06

Alteration Rights Reserved

SAFETY FIRST!

Please Read This Before Installing Or Operating Pump.
This information is provided for **SAFETY and to PREVENT EQUIPMENT PROBLEMS**. To help recognize this information, observe the following symbols:



IMPORTANT! Warns about hazards that can result in personal injury or Indicates factors concerned with assembly, installation, operation, or maintenance which could result in damage to the machine or equipment if ignored.

CAUTION ! Warns about hazards that can or will cause minor personal injury or property damage if ignored. Used with symbols below.

WARNING ! Warns about hazards that can or will cause serious personal injury, death, or major property damage if ignored. Used with symbols below.



Hazardous fluids can cause fire or explosions, burnes or death could result.



Extremely hot - Severe burnes can occur on contact.



Biohazard can cause serious personal injury.



Hazardous fluids can Hazardous pressure, eruptions or explosions could cause personal injury or property damage.



Rotating machinery Amputation or severe laceration can result.



Hazardous voltage can shock, burn or cause death.

Only qualified personnel should install, operate and repair pump. Any wiring of pumps should be performed by a qualified electrician.



WARNING ! - To reduce risk of electrical shock, pumps and control panels must be properly grounded in accordance with the National Electric Code (NEC) or the Canadian Electrical Code (CEC) and all applicable state, province, local codes and ordinances.



WARNING! - To reduce risk of electrical shock, always disconnect the pump from the power source before handling or servicing. Lock out power and tag.



WARNING! Operation against a closed discharge valve will cause premature bearing and seal failure on any pump, and on end suction and self priming pump the heat build may cause the generation of steam with resulting dangerous pressures. It is recommended that a high case temperature switch or pressure relief valve be installed on the pump body.



CAUTION ! Never operate a pump with a plug-in type power cord without a ground fault circuit interrupter.



CAUTION! Pumps build up heat and pressure during operation-allow time for pumps to cool before handling or servicing.



WARNING! - **DO NOT** pump hazardous materials (flammable, caustic, etc.) unless the pump is specifically designed and designated to handle them.



Do not block or restrict discharge hose, as discharge hose may whip under pressure.



WARNING! - DO NOT wear loose clothing that may become entangled in the impeller or other moving parts.



WARNING! - Keep clear of suction and discharge openings. **DO NOT** insert fingers in pump with power connected.



Always wear eye protection when working on pumps.



Make sure lifting handles are securely fastened each time before lifting. **DO NOT** operate pump without safety devices in place. Always replace safety devices that have been removed during service or repair. Secure the pump in its operating position so it can not tip over, fall or slide.



DO NOT exceed manufacturers recommendation for maximum performance, as this could cause the motor to overheat.



DO NOT remove cord and strain relief. Do not connect conduit to pump.



WARNING! Cable should be protected at all times to avoid punctures, cut, bruises and abrasions - inspect frequently. Never handle connected power cords with wet hands.



WARNING! To reduce risk of electrical shock, all wiring and junction connections should be made per the NEC or CEC and applicable state or province and local codes. Requirements may vary depending on usage and location.



WARNING! Submersible Pumps are not approved for use in swimming pools, recreational water installations, decorative fountains or any installation where human contact with the pumped fluid is common.



WARNING! Products Returned Must Be Cleaned, Sanitized, Or Decontaminated As Necessary Prior To Shipment, To Insure That Employees Will Not Be Exposed To Health Hazards In Handling Said Material. All Applicable Laws And Regulations Shall Apply.



Bronze/brass and bronze/brass fitted pumps may contain lead levels higher than considered safe for potable water systems. Lead is known to cause cancer and birth defects or other reproductive harm. Various government agencies have determined that leaded copper alloys should not be used in potable water applications. For non-leaded copper alloy materials of construction, please contact factory.



IMPORTANT! - Crane Pumps & Systems, Inc. is not responsible for losses, injury, or death resulting from a failure to observe these safety precautions, misuse or abuse of pumps or equipment.

SECTION: A - PUMP SPECIFICATIONS

DISCHARGE 8" NPT, 125 lb. Flange Horizontal
LIQUID TEMPERATURE ... 104°F (40°C) Continuous
VOLUTE Cast Iron ASTM A-48, Class 30
 with Cast Iron Wear Ring
MOTOR HOUSING Cast Iron ASTM A-48, Class 30
SEAL PLATE Cast Iron ASTM A-48, Class 30
IMPELLER:
 Design..... 3 Vane, Enclosed with Bronze wear
 ring and pump out vanes on back
 side. Dynamically Balanced ISO
 G6.3
 Material Cast Iron ASTM A-48, Class 30
SHAFT 416 Stainless Steel
SQUARE RINGS..... Buna-N
HARDWARE 300 Series Stainless Steel
LIFTING CHAIN Yoke, Galvanized
PAINT Air Dry Enamel.
SEAL: *Design* Tandem Mechanical, Oil Filled
 Reservoir.
 Material..... Rotating Faces - Carbone
 Stationary Faces - Ceramic
 Elastomer - Buna-N
 Hardware -300 Series Stainless
CORD ENTRY 25 ft. (7.6 m) Std. Cord. Epoxy
 Sealed Housing with Secondary
 Pressure Grommet for Sealing and
 Strain Relief

SPEED 870, 1150, 1750 RPM (Nominal)
UPPER BEARING:
 Design Single Row, Ball, Grease Lubricated
 Load Radial
LOWER BEARING:
 Design Double Row, Ball, Grease Lubricated
 Load..... Radial & Thrust
MOTOR: *Design* NEMA B, Three Phase Torque Curve
 Air-Filled, Squirrel Cage Induction
 "UL" Listed for Class I, Groups C &
 D, Division 1, Explosion Proof
 Insulation..... Class F.
SINGLE PHASE..... Capacitor Start/Induction Run.
 Start Capacitors included with
 pump assembly. Controls require
 external overload protection.
THREE PHASE Dual Voltage 230/460; Requires
 Overload Protection to be Included
 in control panel.
MOISTURE SENSOR Normally Open (N/O), Requires
 Relay in Control Panel
TEMP SENSOR Normally Closed (N/C), Requires
 Relay in Control Panel
OPTIONAL EQUIPMENT: Seal Material, Impeller Trims,
 Additional Cord

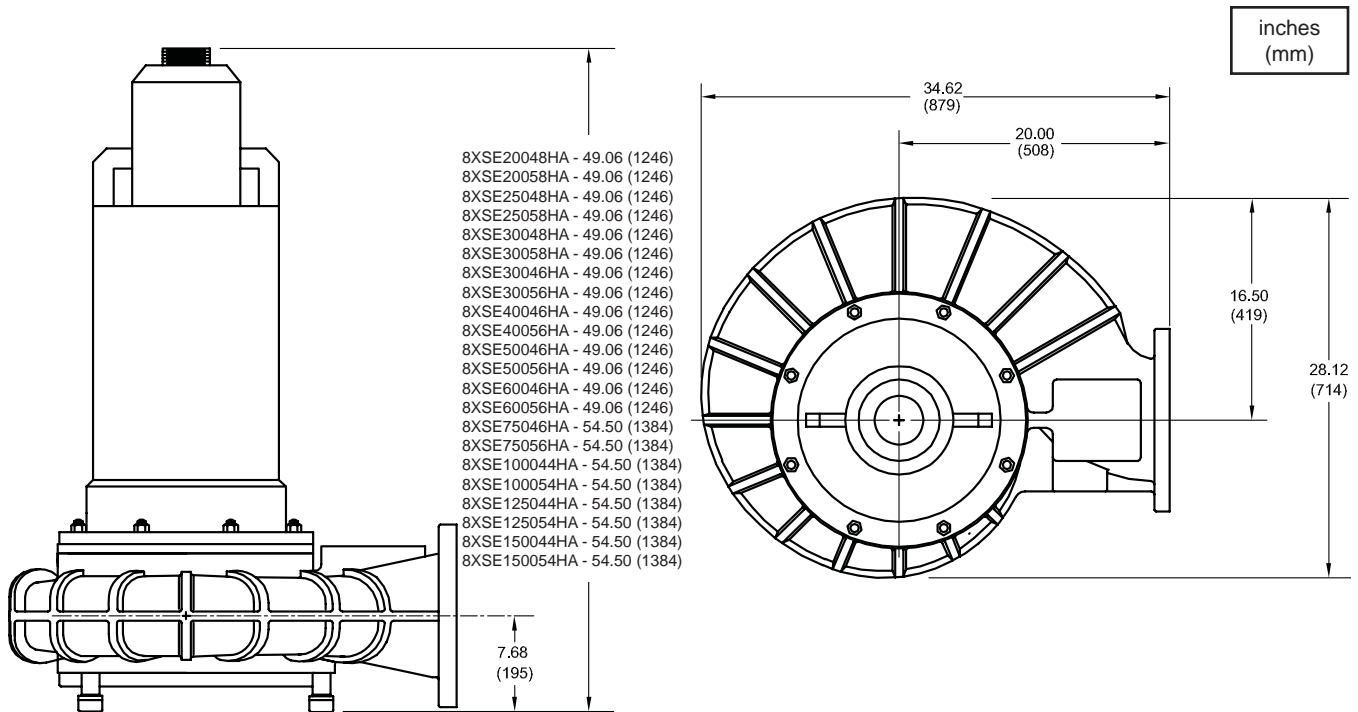

IMPORTANT !

- 1.) MOISTURE AND TEMPERATURE SENSORS MUST BE CONNECTED TO VALIDATE THE UL LISTING.
- 2.) A **NON-SPARKING** BREAK AWAY FITTING MUST BE USED TO VALIDATE THE UL LISTING.
- 3.) A SPECIAL MOISTURE SENSOR RELAY IS REQUIRED IN THE CONTROL PANEL FOR PROPER OPERATION OF THE MOISTURE SENSORS. CONTACT BARNES PUMPS FOR INFORMATION CONCERNING MOISTURE SENSING RELAYS FOR CUSTOMER SUPPLIED CONTROL PANELS.
- 4.) THESE PUMPS ARE UL LISTED FOR PUMPING WATER AND WASTEWATER. **DO NOT USE TO PUMP FLAMMABLE LIQUIDS.**
- 5.) INSTALLATIONS SUCH AS DECORATIVE FOUNTAINS OR WATER FEATURES PROVIDED FOR VISUAL ENJOYMENT MUST BE INSTALLED IN ACCORDANCE WITH THE NATIONAL ELECTRIC CODE ANSI/NFPA 70 AND/OR THE AUTHORITY HAVING JURISDICTION. THIS PUMP IS NOT INTENDED FOR USE IN SWIMMING POOLS, RECREATIONAL WATER PARKS, OR INSTALLATIONS IN WHICH HUMAN CONTACT WITH PUMPED MEDIA IS A COMMON OCCURRENCE.

SECTION B: GENERAL INFORMATION

B-1) To the Purchaser:

Congratulations! You are the owner of one of the finest pumps on the market today. CP&S pumps are products engineered and manufactured of high quality components. Over one hundred years of pump building experience along with a continuing quality assurance program combine to produce a pump which will stand up to the toughest applications. This manual will provide helpful information concerning installation, maintenance, and proper service guidelines.

B-2) Receiving:

Upon receiving the pump, it should be inspected for damage or shortages. If damage has occurred, file a claim immediately with the company that delivered the pump. If the manual is removed from the packaging, do not lose or misplace.

B-3) Storage:

Short Term- CP&S Pumps are manufactured for efficient performance following short inoperative periods in storage. For best results, pumps can be retained in storage, as factory assembled, in a dry atmosphere with constant temperatures for up to six (6) months.

Long Term - Any length of time exceeding six (6) months, but not more than twenty-four (24) months. The unit should be stored in a temperature controlled area, a roofed over walled enclosure that provides protection from the elements (rain, snow, wind-blown dust, etc.), and whose temperature can be maintained between +40 deg. F and +120 deg. F. (4.4 - 49°C). Pump should be stored in its original shipping container. On initial start up, rotate impeller by hand to assure seal and impeller rotate freely. If it is required that the pump be installed and tested before the long term storage begins, such installation will be allowed provided:

- 1.) The pump is not installed under water for more than one (1) month.
- 2.) Immediately upon satisfactory completion of the test, the pump is removed, thoroughly dried, repacked in the original shipping container, and placed in a temperature controlled storage area.

B-4) Service Centers:

For the location of the nearest Barnes Service Center, check your Barnes representative or Crane Pumps & Systems, Inc., Service Department in Piqua, Ohio, telephone (937) 778-8947 or Crane Pumps & Systems Canada, in Brampton, Ontario, (905) 457-6223.

SECTION C: INSTALLATION

C-1) Location:

These self-contained pumping units are Listed for Class I, Groups C & D, Division 1 locations and are recommended for use in a sump, lift station or basin. This pump is designed for submerged continuous duty (15 minutes duty in air at nameplate horsepower), pumping sewage, effluent, wastewater or other nonexplosive or noncorrosive liquids not above 104°F (40°C). Never install the pump in a trench, ditch or hole with a dirt bottom; the legs will sink into the dirt and the suction will become plugged.

C-1.1) Submergence:

It is recommended that the pump be operated in the submerged condition and the sump liquid level should never be less than dimension "A" in Figure 1. The time required to draw the well down from top of motor to the minimum submergence level should not be greater than 15 minutes.

NOTE: Outer shaft seal must be in liquid when motor is operated, whether motor is submerged or in air.

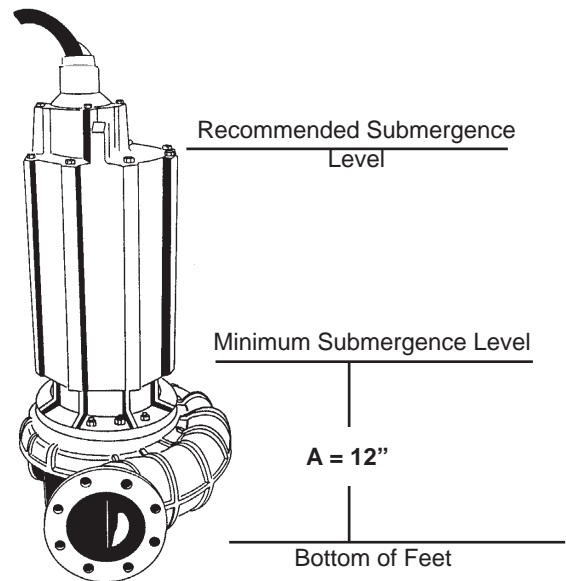

FIGURE 1

C-2) Discharge:

Discharge piping should be as short as possible. Both a check valve and a shut-off valve are recommended for each pump being used. The check valve is used to prevent backflow into the sump. Excessive backflow can cause flooding and/or damage to the pump. The shut-off valve is used to stop system flow during pump or check valve servicing.



WARNING ! - These pumps are suitable for application in CLASS I, GROUPS C & D, HAZARDOUS LOCATIONS and require a non-sparking break away fitting. Failure to use the non-sparking BAF voids warranty.

Barnes Pumps, Inc. supplies a Non-Sparking break away fitting discharge system designed to allow the submersible wastewater pump to be installed or removed without requiring personnel to enter the wet well.

Place the Break Away Fitting (BAF) in position. Temporarily secure the guide rails in the upper mounting brackets and locate the base elbow on the bottom of the wet well. Level the base elbow with grout and/or shims. Install the intermediate support brackets, if required. Make sure the rails are in a true vertical position so the pump will clear the access opening and will slide freely down the rails into place on the discharge base elbow. Once the rails are in proper alignment, bolt the base elbow into the floor of the station and connect the discharge pipe to the elbow. Connect the movable portion and other supplied fittings of the BAF onto the pump and lower into wet well. See the Break Away Fitting manual for more information.

If a rigid conduit is used to install the pump it must meet Class I, Division 1 requirements of the National Electrical Code. Conduit must be stainless steel or coated metal, resistant to sewage water.

C-3) Liquid Level Controls: Intrinsically Safe

WARNING ! - Level control floats used within the hazardous location, must be in an intrinsically safe control circuit suitable for use in CLASS I, GROUPS C & D, HAZARDOUS LOCATIONS.

The level controls are to be supported by a mounting bracket that is attached to the sump wall, cover or junction box. Cord grips are used to hold the cords in place on the mounting bracket. The control level can be changed by loosening the grip and adjusting the cord length as per the plans and specifications. Be certain that the level controls cannot hang up or foul in it's swing and that the entire pump is still submerged when the level control is in the "Off" mode.

A Warrick Control® intrinsically safe relay, Series 27, is an acceptable panel mounted relay, providing the relay is properly installed and maintained.

The primary (A.C. supply line) circuit is not intrinsically safe, therefore the relay must be located in a "SAFE" location (a place that is not classified as a hazardous location). The secondary circuit is intrinsically safe, however, any splice must be made in a "SAFE" location and any control cord that is cut or damaged must be replaced immediately.

C-3.1) Level Control Float System:

It is recommended to use a two float, on and off, level control system. An additional float, incorporated with an alternator switching system will be required for a duplex system. A high level alarm may be required to alert maintenance personnel. A low level cut off may be required to provide system shutdown if the main level control system malfunctions. The off or low level float should be positioned so that the liquid level never drops below the minimum submergence level.

C-4) Electrical Connections:

WARNING! - All model pumps and control panels must be properly grounded per the National Electric Code or Canadian Electric Code, state, province and local codes. Improper grounding voids warranty.

All electrical controls and motor starting equipment must be installed outside the hazardous area unless approved explosion proof controls are used.

C-4.1) Power Cable:

The cord assembly mounted to the pump must not be modified in any way except for shortening to a specific application. Any splice between the pump and the control panel must be made in accordance with all applicable electric codes. It is recommended that a junction box (if used) with seal fittings be mounted outside the sump or be of at least Nema 7 (EEMAC-7) explosion proof construction if located within the wet well. A UL listed seal fitting MUST be used in conduit leaving the hazardous location. **DO NOT USE THE POWER CABLE TO LIFT PUMP.**

C-4.2) Control Cable:

The cord assembly mounted to the pump must not be modified in any way except for shortening to a specific application. Any splice between the pump and the control panel must be made in accordance with all applicable electric codes. It is recommended that a junction box (if used) with seal fittings be mounted outside the sump or be of at least Nema 7 (EEMAC-7) explosion proof construction if located within the wet well. A UL listed seal fitting MUST be used in conduit leaving the hazardous location. **DO NOT USE THE CONTROL CABLE TO LIFT PUMP.**

C-4.3) Wire Size:

If additional cable is required consult a qualified electrician for proper wire size. See table for further electrical information.

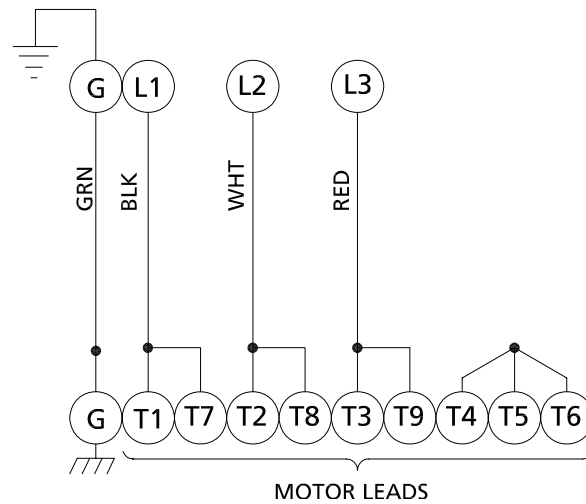

THREE PHASE, 200-230 VOLT AC

Power Cable	Motor Lead Number
Green (Ground)	Green
White	2 & 8
Red	3 & 9
Black	1 & 7
	4, 5 & 6 Together

MODEL NO	"A" DIM	HP	VOLT/ Ph	Hz	RPM (Nom)	NEMA START CODE	FULL LOAD AMPS	LOCKED ROTOR AMPS	CORD SIZE	CORD TYPE	CORD O.D. ± .02 (.5) in (mm)	WINDING RESISTANCE MAIN
8XSE20048HA	49.06	20	460/3	60	870	G	27.8	141.0	8/4	SOW	0.985 (25)	.76
8XSE20058HA	49.06	20	575/3	60	870	G	22.0	109.0	8/4	SOW	0.985 (25)	1.21
8XSE25048HA	49.06	25	460/3	60	870	G	36.5	174.0	8/4	SOW	0.985 (25)	.52
8XSE25058HA	49.06	25	575/3	60	870	G	28.8	139.2	8/4	SOW	0.985 (25)	
8XSE30048HA	49.06	30	460/3	60	870	F	43.0	199.0	8/4	SOW	0.985 (25)	.42
8XSE30058HA	49.06	30	575/3	60	870	F	34.4	159.0	8/4	SOW	0.985 (25)	.66
8XSE30046HA	49.06	30	460/3	60	1150	G	40.0	210.0	8/4	SOW	0.985 (25)	.36
8XSE30056HA	49.06	30	575/3	60	1150	G	32.0	168.0	8/4	SOW	0.985 (25)	.58
8XSE40046HA	49.06	40	460/3	60	1150	G	52.0	282.0	6/4	SOW	1.125 (29)	.30
8XSE40056HA	49.06	40	575/3	60	1150	G	42.6	226.0	6/4	SOW	1.125 (29)	.47
8XSE50046HA	49.06	50	460/3	60	1150	F	67.0	322.0	4/4	SOW	1.350 (34)	.25
8XSE50056HA	49.06	50	575/3	60	1150	F	53.6	258.0	4/4	SOW	1.350 (34)	.38
8XSE60046HA	49.06	60	460/3	60	1150	F	76.9	409.0	2/4	SOW	1.550 (39)	.17
8XSE60056HA	49.06	60	575/3	60	1150	F	61.4	315.0	2/4	SOW	1.550 (39)	.27
8XSE75046HA	54.50	75	460/3	60	1150	G	92.0	534.0	2/4	SOW	1.550 (39)	.13
8XSE75056HA	54.50	75	575/3	60	1150	G	73.6	427.0	2/4	SOW	1.550 (39)	.23
8XSE100044HA	54.50	100	460/3	60	1750	G	123.0	703.0	1/4	SOW	1.680 (43)	.08
8XSE100054HA	54.50	100	575/3	60	1750	G	98.4	562.0	1/4	SOW	1.680 (43)	.12
8XSE125044HA	54.50	125	460/3	60	1750	F	153.0	864.0	2/0/4	SOW	1.930 (49)	.05
8XSE125054HA	54.50	125	575/3	60	1750	F	122.0	691.0	2/0/4	SOW	1.930 (49)	.08
8XSE150044HA	54.50	150	460/3	60	1750	E	182.0	1080.0	3/0/4	SOW	2.070 (53)	.05
8XSE150054HA	54.50	150	575/3	60	1750	E	145.0	864.0	3/0/4	SOW	2.070 (53)	.07

Moisture and Temperature sensor cord for all models is 18/5 SOW, 0.485 (12.3mm) ± .02 (.51mm) O.D.

Winding Resistance ± 5%. Winding resistance measured in OHMS @ 25°C. (Between Lines)

Pump rated for operation at ± 10% voltage at motor.

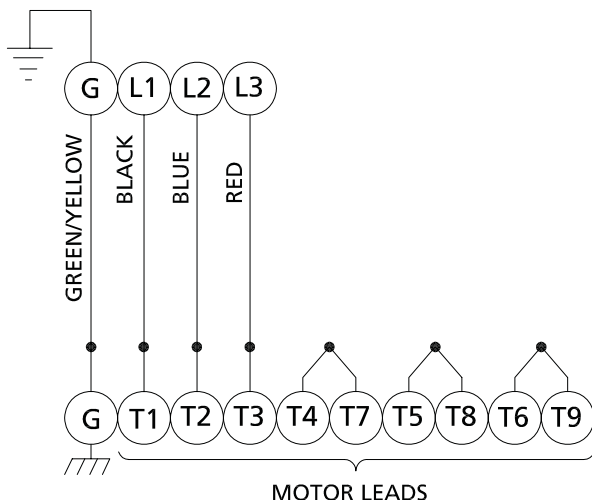

THREE PHASE, 460 VOLT AC

Power Cable	Motor Lead Number
Green(Ground)	Green
Black	1
White	2
Red	3
	4 & 7 Together
	5 & 8 Together
	6 & 9 Together

CONTROL Small Cable

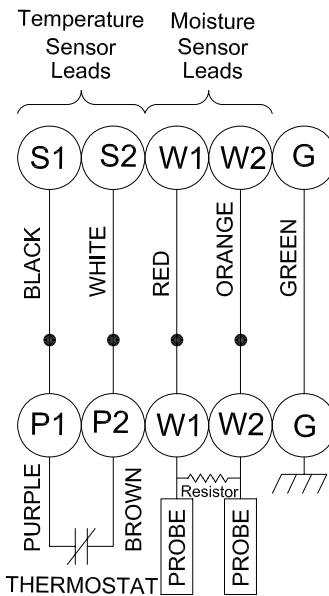

MOISTURE AND TEMPERATURE SENSORS

Control Cable	Lead Number
Black	P1 (Temperature Sensor)
White	P2 (Temperature Sensor)
Red	W1 (Moisture Sensor)
Orange	W2 (Moisture Sensor)
Green	Ground



WARRANTY NOTE: Both the temperature sensor and moisture detection system must be connected to the motor circuitry such that the motor will be de-energized or sound alarm if excessive motor temperatures are reached and/or if water is detected in the seal chamber and/or motor chamber. Failure to have the above mentioned systems installed and operative, nullifies warranty.

C-4.4) Overload Protection:

The normally closed (N/C) thermal sensor is embedded in the motor windings and will detect excessive heat in the event an overload condition occurs which will then trip and stop the pump. The thermal sensor leads marked P1 and P2 **MUST** be connected in series with the stop button of the pilot circuit of the magnetic motor controller located in the control panel so that the thermostat will open the circuit before dangerous temperatures are reached. A manual momentary start switch is required to prevent the automatic restarting of the motor when the thermostat resets. For a typical wiring diagram, refer to Fig. 2. In the event of an overload, the source of this condition should be determined and rectified before the pump is put back into normal operation. **DO NOT LET THE PUMP CYCLE OR RUN IF AN OVERLOAD CONDITION OCCURS!**

If current through the temperature sensor exceeds the values listed, an intermediate control circuit relay must be used to reduce the current or the sensor will not work properly.

TEMPERATURE SENSOR ELECTRICAL RATING		
VOLTS	CONTINUOUS AMPERES	INRUSH AMPERES
110-120	3.00	30.0
220-240	1.50	15.0
440-480	0.75	7.5

C-4.5 Moisture Sensors:

A normally open (N/O) detector is installed in the pump seal chamber, which will detect any moisture present, and a continuity test resistor built into the motor. The test resistor is rated 1 watt at 330K ohms. The moisture sensors **MUST** be connected to moisture detector control, which includes a continuity test circuit, see Fig. 3 for typical wiring diagram. The normally closed (N/C) contact of the moisture detector **MUST** be connected in series with the stop button of the pilot circuit of the magnetic motor controller. A Warrick moisture detection control, Type 2800 is an acceptable control if properly installed and maintained. Wiring must be provided from the moisture detector sensor probe leads of the motor designated W1 and W2 to terminals 9 and 10 of the 2800-XXX control. Terminal pair 1-2 must be continuously energized from an A-C supply line of electrical characteristics shown on the data table. In the event of moisture detection, the pump should be pulled and the source of the failure located and repaired. **IF MOISTURE DETECTION HAS OCCURRED, SCHEDULE MAINTENANCE AS SOON AS POSSIBLE!**

C-4.6) Control Panel and Electrical System:

The control panel and the electrical system **MUST** be properly designed and wired to include at least, but not limited to the following;

- a. Proper grounding per NEC.
- b. A temperature sensing circuit (see Fig. 2A & B)
- c. A moisture detection circuit with continuity test circuit (see Fig. 3)
- d. An intrinsically safe level control system.
- e. A main power manual disconnect and lock out.
- f. A motor starter and overload system.
- g. Single phase only, requires a capacitor power pack (see Fig. 2B).

Control panels for single phase pumps **MUST** be purchased from the factory and it is advisable that all three phase control panels are also purchased from the factory.

SECTION: D START-UP OPERATION

D-1) Check Voltage and Phase:

Before operating pump, compare the voltage and phase information stamped on the pump's identification plate to the available power.

D-2) Check Pump Rotation:

Before putting pump into service for the first time, the motor rotation must be checked. Improper motor rotation can result in poor pump performance and can damage the motor and/or pump. To check the rotation, suspend the pump freely, momentarily apply power and observe the "kickback". "Kickback" should always be in a counter-clockwise direction as viewed from the top of the pump motor housing.

D-2.1) Incorrect Rotation for Three-Phase Pumps:

In the event that the rotation is incorrect for a three-phase installation, interchange any two power cable leads at the control box. **DO NOT** change leads in the cable housing in the motor. Recheck the "kickback" rotation again by momentarily applying power.

D-2.3) Test Procedure For Moisture Sensor Control:

With a Warrick moisture detection control, type 2800, a normally closed push button and neon indicating lamp is provided as a means of checking the moisture sensing components. When the push button is depressed, the indicating lamp will be illuminated to indicate (A) power is supplied to the control, (B) the control is operative, and (C) wiring to the moisture sensing probes in the motor is intact. This procedure should be performed periodically to confirm integrity of the circuit.

D-3) Start-Up Report:

Included at the end of this manual are two start-up report sheets, these sheets are to be completed as applicable. Return one copy to Barnes Pumps, Inc. and store the second in the control panel or with the pump manual if no control panel is used. It is important to record this data at initial start-up since it will be useful to refer to should servicing the pump be required in the future.

D-3.1) Identification Plate:

Record the numbers from the pump's identification plate on both START-UP REPORTS provided at the end of the manual for future reference.

TYPICAL THERMAL PROTECTION WIRING DIAGRAM

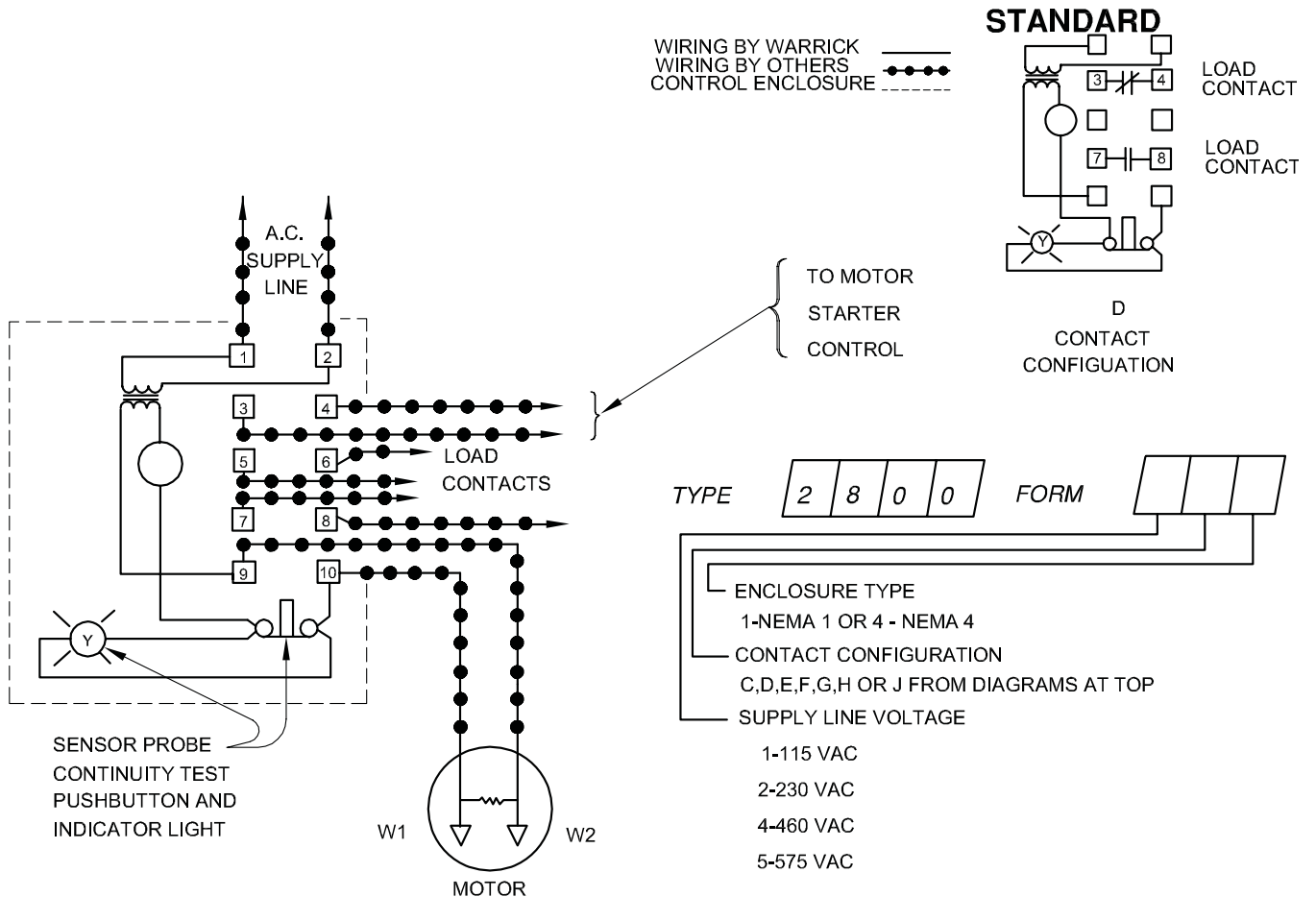
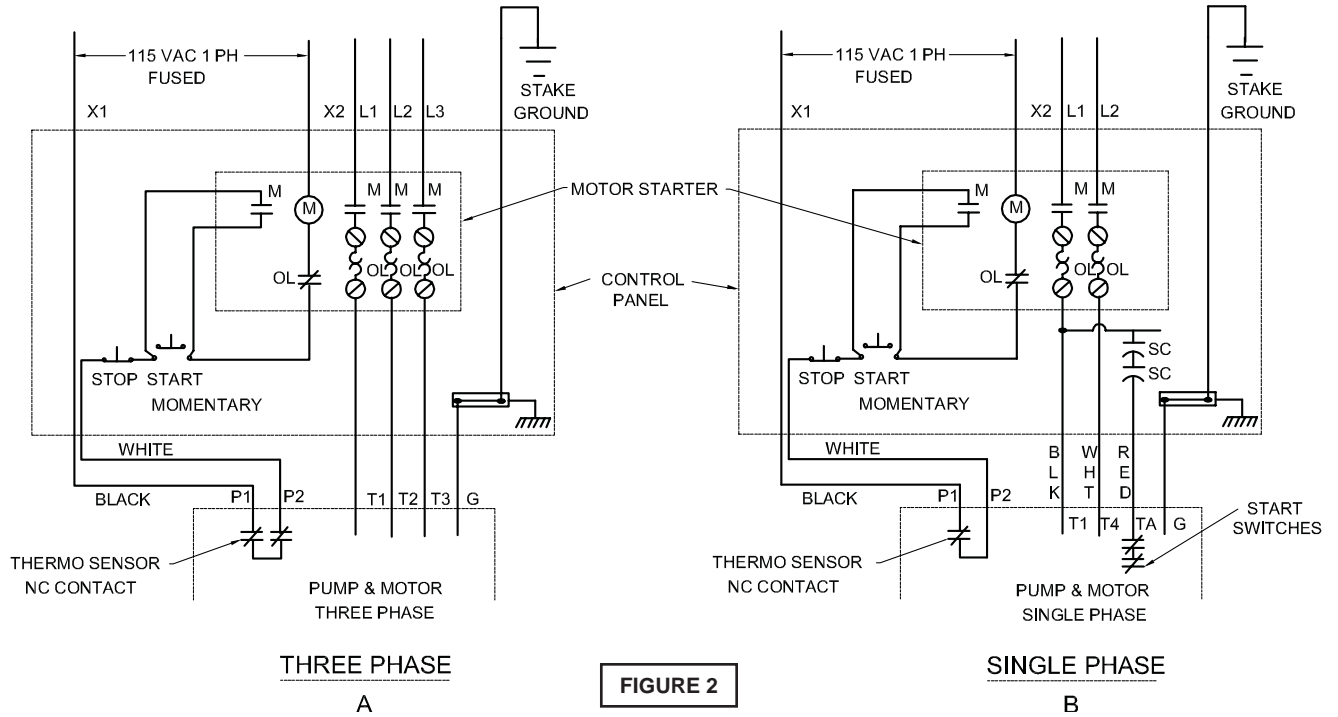

D-3.2) Insulation Test:

Before the pump is put into service, an insulation (megger) test should be performed on the motor. The resistance values (ohms) as well as the voltage (volts) and current (amps) should be recorded on the start-up report.

D-3.3) Pump-Down Test:

After the pump has been properly wired and lowered into the basin, sump or lift station, it is advisable to check the system by filling with liquid and allowing the pump to operate through it's pumping cycle. The time needed to empty the system, or pump-down time along with the volume of water, should be recorded on the start-up report.

SECTION E: PREVENTATIVE MAINTENANCE

As the motor is Air-filled, no lubrication or other maintenance is required, and generally Barnes Pumps will give very reliable service and can be expected to operate for years of normal sewage pumping without failing. However, as with any mechanical piece of equipment a preventive maintenance program is recommended and suggested to include the following checks:

- 1) Test moisture detector control "Test Switch" for continuity of circuit. Water in the seal chamber will energize a seal leak warning light at the control panel. This is a warning light only and does not stop the motor. It indicates the seal has leaked and must be repaired. This should be done within 2 or 3 weeks to prevent further damage. See section D-2.3.
- 2) Inspect impeller and body for excessive build-up or clogging and repair as required per section F-1.
- 3) Inspect outer shaft seal and replace as required per section F-2.
- 4) Check motor for ground leakage and proper amp draw. Motor and inner seal repair per section F-3.

SECTION F: SERVICE AND REPAIR

NOTE: All item numbers in () refer to Figures 7 & 8.



WARNING ! - Electrical power to the pump motors must be disconnected and locked out to prevent any dangerous electrical hazards or personnel danger before any service work is done to the pump.



CAUTION ! - Operating pump builds up heat and pressure; allow time for pump to cool to room temperature before handling or servicing.

F-1) Impeller and Volute Service:

F-1.1) Disassembly and Inspection:

To clean out the pump body (1), or clean out or replace impeller (7), or replace wear ring (1F) and impeller ring (8), disconnect power, remove hex nuts (5) and vertically lift motor assembly from the pump body (1), and then lift out back plate (12). Clean out the pump body, if necessary, examine wear ring (1F) and replace if worn. If the wear ring (1F) requires replacing, split the wear ring (1F) and remove, be careful not to damage the suction cover (1E). Clean and examine impeller (7) for pitting or wear, also check impeller ring (8) for scaring or excessive wear, replace if required.

NOTE: If impeller (7) is replaced, also replace impeller ring (8). If only the impeller ring (8) requires replacing, split the ring and remove, be careful not to damage impeller.

To remove Impeller (7), removing cap screw (10) (or nut) and washer (9) (and spring washer (11) if so equipped). The impeller is keyed onto the shaft with a square key (6) and to remove, pull impeller straight off the shaft using a wheel puller if required. Inspect gasket (1H) if suction cover (1E) has been removed, and replace if cut or damaged. Before reinstallation, check the motor shaft and impeller bore for damage.

F-1.2) Reassembly:

To install wear ring (1F) first apply retaining compound to the bore of suction cover (1E) and then press wear ring (1F) into bore of suction cover (1E) until seated. Position gasket (1H) on volute, and locate suction cover (1E) on volute (1), apply thread locking compound to socket head screws (1D) and tighten into volute (1). To install impeller (7), first apply retaining compound to groove at bottom of impeller and press impeller ring (8) on impeller (7), then apply a thin film of oil to motor shaft and slide impeller straight onto shaft, keeping keyways lined up. Drive key (6) into keyway. Locate spacer (9), and Lock-spring washer (11) on shaft, apply thread locking compound to cap screw (10) threads, thread cap screw (10) into shaft and torque to 35 ft. lbs. Rotate impeller to check for binding.

Install impeller and motor assembly over studs and onto volute (1). Apply thread locking compound to threads of each stud (3). Position lockwasher (5) on studs (3) and thread nut (4) onto stud (3) and torque to 24 ft. lbs. Check for free rotation of motor and impeller.

F-2) Outer Shaft Seal Service:



CAUTION! - Handle seal parts with extreme care. DO NOT scratch or mar lapped surfaces.

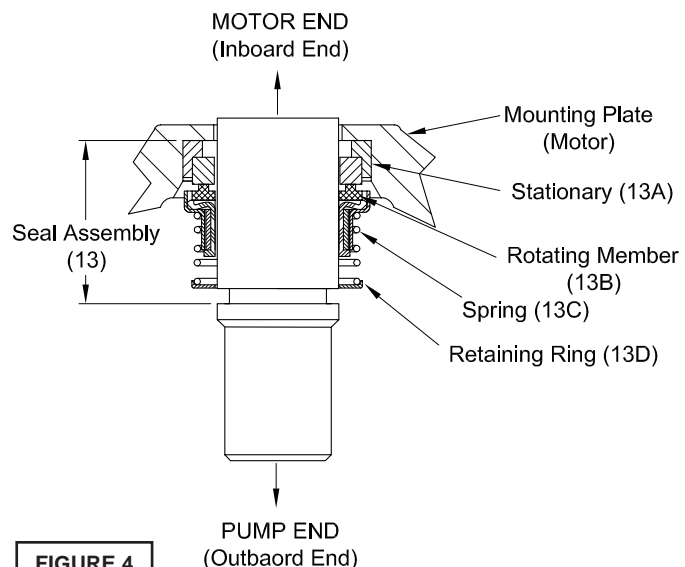

FIGURE 4

F-2.1) Disassembly and Inspection:

To expose outer shaft seal (13) for examination, remove Impeller and Volute per Section F-1.1. Set motor assembly (2) in the up position to prevent loss of oil. Remove snap ring from motor shaft, then retaining ring (13D), spring (13C) and rotating member (13B) from shaft, See Fig. 4. Examine all seal parts and especially contact faces. Inspect seal for signs of wear such as uneven wear pattern on stationary members, chips and scratches on either seal face. **DO NOT** interchange seal components, replace the entire shaft seal (13). If replacing seal, remove stationary (13A) from mounting plate by prying out with flat screw driver.

F-2.2) Reassembly:

Lightly oil (**DO NOT use grease**) outer surface of stationary member (13A). Press stationary member (13A) firmly into mounting plate using a seal pusher, nothing but the seal pusher is to come in contact with seal face (see Fig. 5).



IMPORTANT! - DO NOT hammer on the seal pusher- it will damage the seal face.

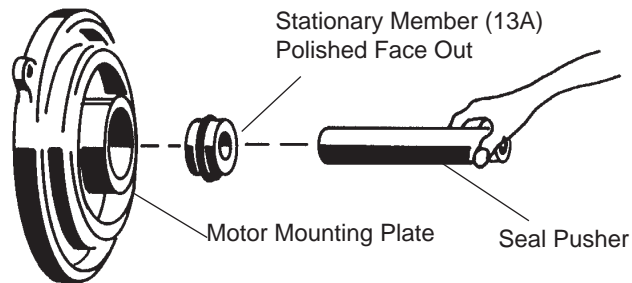

FIGURE 5

Make sure the stationary member is in straight and that the rubber ring is not out of its groove. Lightly oil (**DO NOT use grease**) shaft and inner surface of bellows on rotating member (13B) see Fig. 6. With lapped surface of rotating member (13B) facing inward toward stationary member (13A), slide rotating member (13B) onto shaft using a seal pusher, until lapped faces of (13A) and (13B) are together. (see Fig. 4).

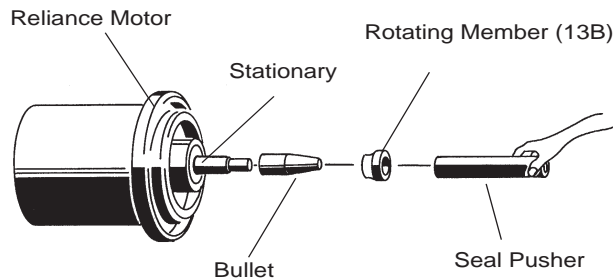

FIGURE 6



IMPORTANT! - It is extremely important to keep seal faces clean during assembly. Dirt particles lodged between these faces will cause the seal to leak.

Place spring (13C) over shaft and in place on rotating member (13B), making sure it is seated on retainer and not cocked or resting on bellows tail. Slide retaining ring (13B) over shaft and let rest on spring (13C). Assemble impeller and volute as outlined in paragraph F-1.2.

F-3) Motor & Inner Shaft Seal Service

The XSE Submersible Pump motor is manufactured by Reliance Electric Co. and must be serviced and repaired by Reliance approved service centers only. For lead reconnection information, contact Reliance Electric Co., giving motor serial number.



WARNING! - These motors are U/L Listed for application in CLASS I, GROUPS C & D EXPLOSION PROOF Environments. All repairs, other than lead reconnects and outer seal replacement, shall be performed by an authorized reliance service facility. Any other repairs performed by the customer or NON-RELIANCE SERVICE Facilities negates the U/L Listing and motor warranty.

SECTION: G REPLACEMENT PARTS

G-1 ORDERING REPLACEMENT PARTS:

When ordering replacement parts, ALWAYS furnish the following information:

1. Pump serial number and date code. (Paragraph G-4)
2. Pump model number. (Paragraph G-3)
3. Pump part number. (Paragraph G-2)
4. Part description.
5. Item part number.
6. Quantity required.
7. Shipping instructions.
8. Billing Instructions.

BARNES®	HP.	Volts	Code	Ph.	Hz.
	RPM	FLA	Model No.	2	
	Part No.	3		Serial No.	1
	Impeller Dia.	Max. Liq. Temp.	°C	Ins. Class	

WARNING TO REDUCE RISK OF ELECTRICAL SHOCK DISCONNECT THE PUMP FROM THE POWER SOURCE BEFORE HANDLING OR SERVICING. SEE INSTRUCTION MANUAL FOR PROPER INSTALLATION. SEE WARNING PLATE FOR ADDITIONAL CAUTIONS.

G-2 PART NUMBER:

The part number consists of a six (6) digit number, which appears in the catalog. A one or two letter suffix may follow this number to designate the design configuration. This number is used for ordering and obtaining information.

G-3 MODEL NUMBER:

This designation consists of numbers and letters which represent the discharge size, series, horsepower, motor phase and voltage, speed and pump design. This number is used for ordering and obtaining information.

G-4 SERIAL NUMBER:

The serial number block will consist of a six digit number, which is specific to each pump and may be preceded by an alpha character, which indicates the plant location. This number will also be suffixed with a four digit number, which indicates the date the unit was built (Date Code). **EXAMPLE: A012345 0490.** Reference the six digit portion (Serial Number) of this number when referring to the product.

TROUBLE SHOOTING

CAUTION ! Always disconnect the pump from the electrical power source before handling.
 If the system fails to operate properly, carefully read instructions and perform maintenance recommendations.
 If operating problems persist, the following chart may be of assistance in identifying and correcting them:
 MATCH "CAUSE" NUMBER WITH CORRELATING "CORRECTION" NUMBER.

NOTE: Not all problems and corrections will apply to each pump model.

PROBLEM	CAUSE	CORRECTION
Pump will not run	<ol style="list-style-type: none"> 1. Poor electrical connection, blown fuse, tripped breaker or other interruption of power, improper power supply. 2. Motor or switch inoperative (to isolate cause, go to manual operation of pump). 2a. Float movement restricted. 2b. Switch will not activate pump or is defective. 2c. Defective motor 3. Insufficient liquid level. 	<ol style="list-style-type: none"> 1. Check all electrical connections for security. Have electrician measure current in motor leads, if current is within $\pm 20\%$ of locked rotor Amps, impeller is probably locked. If current is 0, overload may be tripped. Remove power, allow pump to cool, then recheck current. 2a. Reposition pump or clean basin as required to provide adequate clearance for float. 2b. Disconnect level control. Set ohmmeter for a low range, such as 100 ohms full scale and connect to level control leads. Actuate level control manually and check to see that ohmmeter shows zero ohms for closed switch and full scale for open switch. (Float Switch). 2c. Check winding insulation (Megger Test) and winding resistance. If check is outside of range, dry and recheck. If still defective, replace per service instructions.
Pump will not turn off	<ol style="list-style-type: none"> 2a. Float movement restricted. 2b. Switch will not activate pump or is defective. 4. Excessive inflow or pump not properly sized for application. 9. Pump may be airlocked 14. H-O-A switch on panel is in "HAND" position 	<ol style="list-style-type: none"> 3. Make sure liquid level is at least equal to suggested turn-on point. 4. Recheck all sizing calculations to determine proper pump size. 5. Check discharge line for restrictions, including ice if line passes through or into cold areas. 6. Remove and examine check valve for proper installation and freedom of operation. 7. Open valve.
Pump hums but does not run	<ol style="list-style-type: none"> 1. Incorrect voltage 8. Impeller jammed or loose on shaft, worn or damaged, impeller cavity or inlet plugged. 	<ol style="list-style-type: none"> 8. Check impeller for freedom of operation, security and condition. Clean impeller and inlet of any obstruction. 9. Loosen union slightly to allow trapped air to escape. Verify that turn-off level of switch is set so that the suction is always flooded. Clean vent hole.
Pump delivers insufficient capacity	<ol style="list-style-type: none"> 1. Incorrect voltage. 4. Excessive inflow or pump not properly sized for application. 5. Discharge restricted. 6. Check valve stuck closed or installed backwards. 7. Shut-off valve closed. 8. Impeller jammed or loose on shaft, worn or damaged, impeller cavity or inlet plugged. 9. Pump may be airlocked. 10. Pump running backwards 	<ol style="list-style-type: none"> 10. Check rotation. If power supply is three phase, reverse any two of three power supply leads to ensure proper impeller rotation.. 11. Repair fixtures as required to eliminate leakage. 12. Check pump temperature limits & fluid temperature. 13. Replace portion of discharge pipe with flexible connector. 14. Turn to automatic position. 15. Check for leaks around basin inlet and outlets.
Pump cycles too frequently or runs periodically when fixtures are not in use	<ol style="list-style-type: none"> 6. Check valve stuck closed or installed backwards. 11. Fixtures are leaking. 15. Ground water entering basin. 	
Pump shuts off and turns on independent of switch, (trips thermal overload protector). CAUTION! Pump may start unexpectedly. Disconnect power supply.	<ol style="list-style-type: none"> 1. Incorrect voltage. 4. Excessive inflow or pump not properly sized for application. 8. Impeller jammed, loose on shaft, worn or damaged, impeller cavity or inlet plugged. 12. Excessive water temperature. (internal protection only) 	
Pump operates noisily or vibrates excessively	<ol style="list-style-type: none"> 2c. Worn bearings, motor shaft bent. 5. Debris in impeller cavity or broken impeller 10. Pump running backwards 13. Piping attachments to building structure too rigid or too loose. 	

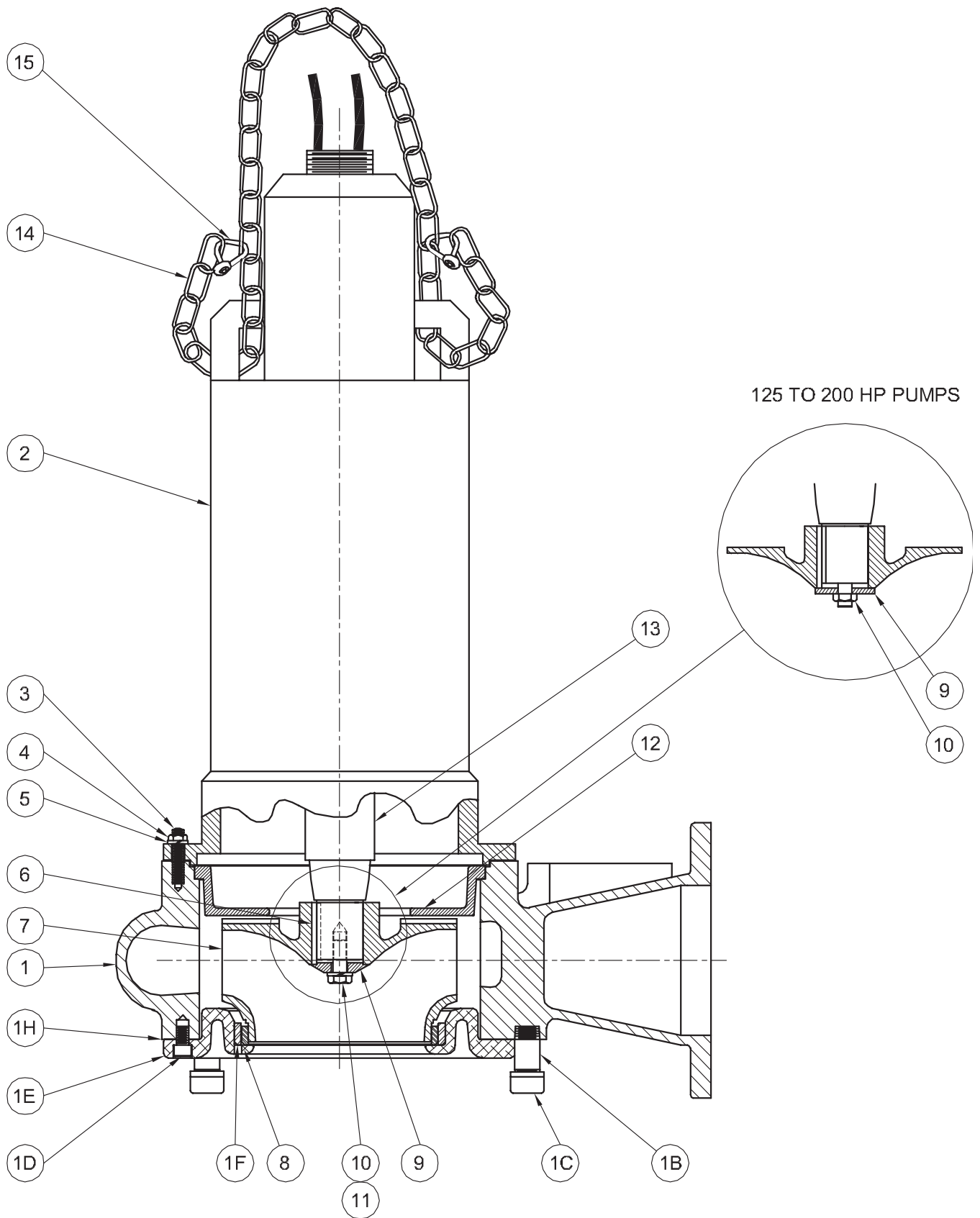
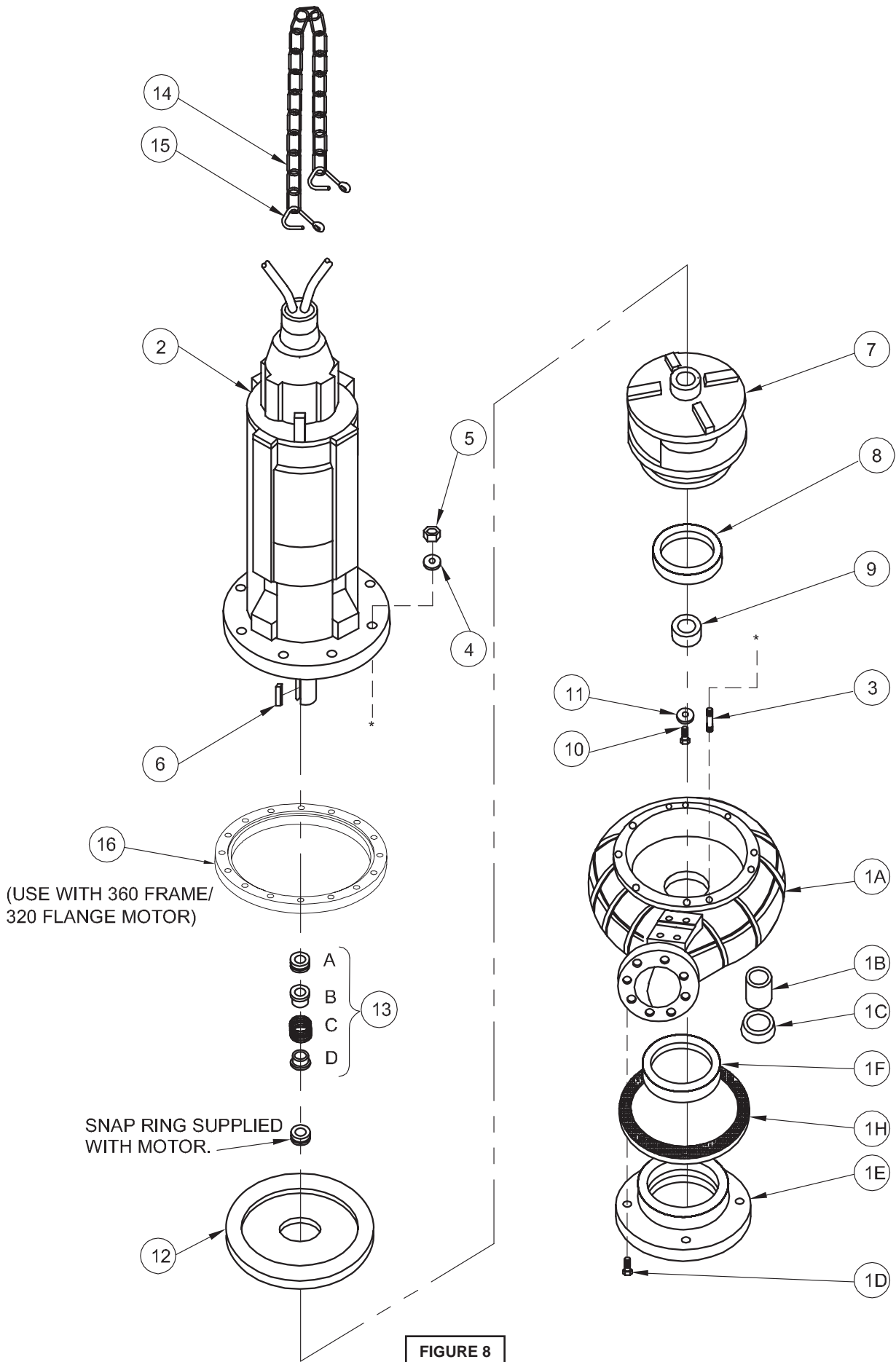

FIGURE 7



PARTS LIST

ITEM	QTY	PART NO.	DESCRIPTION		
1	1	084851	Volute Assembly		
1A	1	079698	* Volute		
1B	4	005810	* Nipple		
1C	4	014256	* Nipple Cap		
1D	8	079380	* Soc. Hd. Screw	5/8-11 x 1" Lg Stainless	
1E	1	079190	* Suction Cover		
1F	1	079369	* Wear Ring	Bronze	
1G	2	078994	* Dowel Pin		
1H	1	079587	* Gasket		
2	1	See Table 1	Motor (See Note: 1)		
3	8	079379	Stud	5/8 x 3" Lg Stainless	20HP - 60HP
	16	079379	Stud	5/8 x 3" Lg Stainless	75HP - 150HP
4	8	038519	Lockwasher	5/8 Stainless	20HP - 60HP
	16	038519	Lockwasher	5/8 Stainless	75HP - 150HP
5	8	15-21-1	Hex Nut	5/8-11 Stainless	20HP - 60HP
	16	15-21-1	Hex Nut	5/8-11 Stainless	75HP - 150HP
6	1	079381	Key	1/2 Sq x 3" Lg Stainless	
7	1		Impeller, Cast Iron		
		083723	14.50" Dia.	75HP-1150	
		083723TA	14.38" Dia.		
		083723TB	14.25" Dia.		
		083723TC	14.12" Dia.		
		083723TD	14.00" Dia.	60HP-1150	
		083723TE	13.88" Dia.		
		083723TF	13.75" Dia.		
		083723TG	13.62" Dia.		
		083723TH	13.50" Dia.	50HP-1150	
		083723TJ	13.38" Dia.		
		083723TK	13.25" Dia.		
		083723TL	13.12" Dia.		
		083723TM	13.00" Dia.		
		083723TN	12.88" Dia.		
		083723TP	12.75" Dia.	150HP-1750	
		083723TQ	12.62" Dia.		
		083723TR	12.50" Dia.	30HP-870, 40HP-1150, 125HP-1750	
		083723TS	12.38" Dia.		
		083723TT	12.25" Dia.		
		083723TU	12.12" Dia.		
		083723TV	12.00" Dia.		
		083723TW	11.88" Dia.		
		083723TX	11.75" Dia.		
		083723TY	11.62" Dia.		
		083723TZ	11.50" Dia.	25HP-870, 30HP-1150	
		083723UA	11.38" Dia.		
		083723UB	11.25" Dia.		
		083723UC	11.12" Dia.		
		083723UD	11.00" Dia.	100HP-1750	
		083723UE	10.88" Dia.		
		083723UF	10.75" Dia.		
		083723UG	10.62" Dia.		
		083723UH	10.50" Dia.	20HP-870	
8	1	079377	Impeller Ring	Bronze	
9	1	079588	Impeller Washer,	20 to 60 HP	Stainless
	1	079376		75 to 135 HP	Stainless
10	1	1-111-1	Hex Hd. Cap Screw,	20 to 60HP	3/4-10 x 2" Lg Stainless
	1	(Supplied with Motor)	Nut, 75 to 135HP	1-1/2-12 Stainless	
11	1	052699	Lock-Spring Washer ,	20 to 60HP	3/4 Steel
		(Not Used)		75 to 135HP	
12	1	079191	Back Plate		
13	1	085980	Outer Seal (See Note: 2)	Carbon/Ceramic/Buna-N (STD)	20HP - 60HP
		084259	Outer Seal (See Note: 2)	Carbon/Ceramic/Buna-N (STD)	75HP - 150HP
		085981	(OPTIONAL, Pump End)	Tungsten/Carbide/Buna-N	20HP - 60HP
		085982	(OPTIONAL, Pump End)	Tungsten/Carbide/Buna-N	75HP - 150HP
14	5Ft.	625-01583	Chain	.375 Steel	
15	3	625-00826	Cold Shut	.437	
16	1	124823	Adapter (Used with 360 Frame/320 Flange Motor)		

PUMP MODEL	TABLE 1 - MOTOR WITH VARIOUS CORD LENGTHS					
	25FT	30FT	40FT	50FT	75FT	100FT
8XSE20048HA	079688	079688XC	079688XE	079688XF	079688XH	079688XL
8XSE20058HA	095171	095171XC	095171XE	095171XF	095171XH	095171XL
8XSE25048HA	079689	079689XC	079689XE	079689XF	079689XH	079689XL
8XSE25058HA	095172	095172XC	095172XE	095172XF	095172XH	095172XL
8XSE30048HA	079690	079690XC	079690XE	079690XF	079690XH	079690XL
8XSE30058HA	095173	095173XC	095173XE	095173XF	095173XH	095173XL
8XSE30046HA	083725	083725XC	083725XE	083725XF	083725XH	083725XL
8XSE30056HA	092836	092836XC	092836XE	092836XF	092836XH	092836XL
8XSE40046HA	079691	079691XC	079691XE	079691XF	079691XH	079691XL
8XSE40056HA	092835	092835XC	092835XE	092835XF	092835XH	092835XL
8XSE50046HA	079692	079692XC	079692XE	079692XF	079692XH	079692XL
8XSE50056HA	092834	092834XC	092834XE	092834XF	092834XH	092834XL
8XSE60046HA	079591	079591XC	079591XE	079591XF	079591XH	079591XL
8XSE60056HA	093644	093644XC	093644XE	093644XF	093644XH	093644XL
8XSE75046HA	079693	079693XC	079693XE	079693XF	079693XH	079693XL
8XSE75056HA	092833	092833XC	092833XE	092833XF	092833XH	092833XL
8XSE100044HA	079378	079378XC	079378XE	079378XF	079378XH	079378XL
8XSE100054HA	092831	092831XC	092831XE	092831XF	092831XH	092831XL
8XSE125044HA	079694	079694XC	079694XE	079694XF	079694XH	079694XL
8XSE125054HA	092832	092832XC	092832XE	092832XF	092832XH	092832XL
8XSE150044HA	079874	079874XC	079874XE	079874XF	079874XH	079874XL
8XSE150054HA	092830	092830XC	092830XE	092830XF	092830XH	092830XL

NOTE: 1 Standard motor includes, 25 foot power and control cables, moisture & temperature sensors and carbon/ceramic/buna-n Inner & Outer shaft seals.

NOTE: 2 When ordering motor (item 2), Outer seal is supplied. Item 13 is for Outer seal replacement ONLY. When ordering outer seal, furnish Reliance motor serial number.

IMPORTANT!
WARRANTY REGISTRATION

Your product is covered by the enclosed Warranty.
Complete the Warranty Registration Form and return to
Crane Pumps & Systems, Inc. Warranty Service Group

If you have a claim under the provision of the warranty, contact your local
Crane Pumps & Systems, Inc. Distributor.

RETURNED GOODS

**RETURN OF MERCHANDISE REQUIRES A "RETURNED GOODS AUTHORIZATION".
CONTACT YOUR LOCAL CRANE PUMPS & SYSTEMS, INC. DISTRIBUTOR.**



**Products Returned Must Be Cleaned, Sanitized,
Or Decontaminated As Necessary Prior To Shipment,
To Insure That Employees Will Not Be Exposed To Health
Hazards In Handling Said Material. All Applicable Laws
And Regulations Shall Apply.**

BARNES®

Limited Warranty

We warrant to our immediate customer and to the ultimate consumer that products of our manufacture will be free of defects in material and workmanship under normal use and service for the following time periods, when installed and maintained in accordance with our instructions.

Pump Products: One (1) year from date of installation or (24) twenty-four months from date of shipment, whichever occurs first. Cleaning Products: Twelve (12) months from date of installation or eighteen (18) months from date of shipment, whichever occurs first. As used herein, "the ultimate consumer" is defined as the purchaser who first uses the product after its initial installation or, in the case of product designed for non permanent installation, the first owner who used the product. It is the purchaser's or any sub-vendee's obligation to make known to the ultimate consumer the terms and conditions of this warranty. This warranty gives you specific legal rights, and there may also be other rights which vary from state to state. In the event the product is covered by the Federal Consumer Product Warranties Law (1) the duration of any implied warranties associated with the product by virtue of said law is limited to the same duration as stated herein, (2) this warranty is a LIMITED WARRANTY, and (3) no claims of any nature whatsoever shall be made against us, until the ultimate consumer, his successor, or assigns, notifies us in writing of the defect, and delivers the product and/or defective part(s) freight prepaid to our factory or nearest authorized service station. Some states do not allow limitations on how long an implied warranty lasts, so the above limitation may not apply. **THE SOLE AND EXCLUSIVE REMEDY FOR BREACH OF ANY AND ALL WARRANTIES WITH RESPECT TO ANY PRODUCT SHALL BE TO REPLACE OR REPAIR AT OUR ELECTION, F.O.B. POINT OF MANUFACTURE OR AUTHORIZED REPAIR STATION, SUCH PRODUCTS AND/OR PARTS AS PROVEN DEFECTIVE. THERE SHALL BE NO FURTHER LIABILITY, WHETHER BASED ON WARRANTY, NEGLIGENCE OR OTHERWISE.** Unless expressly stated otherwise, guarantees in the nature of performance specifications furnished in addition to the foregoing material and workmanship warranties on a product manufactured by us, if any, are subject to laboratory tests corrected for field performance. Any additional guarantees, in the nature of performance specifications must be in writing and such writing must be signed by our authorized representative. Due to inaccuracies in field testing if a conflict arises between the results of field testing conducted by or for user, and laboratory tests corrected for field performance, the latter shall control. Components or accessories supplied by us but manufactured by others are warranted only to the extent of and by the terms and conditions of the original manufacturer's warranty. **RECOMMENDATIONS FOR SPECIAL APPLICATIONS OR THOSE RESULTING FROM SYSTEMS ANALYSES AND EVALUATIONS WE CONDUCT WILL BE BASED ON OUR BEST AVAILABLE EXPERIENCE AND PUBLISHED INDUSTRY INFORMATION. SUCH RECOMMENDATIONS DO NOT CONSTITUTE A WARRANTY OF SATISFACTORY PERFORMANCE AND NO SUCH WARRANTY IS GIVEN.**

This warranty shall not apply when damage is caused by (a) improper installation, (b) improper voltage (c) lightning (d) sand or other abrasive material (e) scale or corrosion build-up due to excessive chemical content. Any modification of the original equipment will also void the warranty. We will not be responsible for loss, damage or labor cost due to interruption of service caused by defective parts. Neither will we accept charges incurred by others without our prior written approval. This warranty is void if our inspection reveals the product was used in a manner inconsistent with normal industry practice and/or our specific recommendations. The purchaser is responsible for communication of all necessary information regarding the application and use of the product. **UNDER NO CIRCUMSTANCES WILL WE BE RESPONSIBLE FOR ANY OTHER DIRECT OR CONSEQUENTIAL DAMAGES, INCLUDING BUT NOT LIMITED TO LOST PROFITS, LOST INCOME, LABOR CHARGES, DELAYS IN PRODUCTION, IDLE PRODUCTION, WHICH DAMAGES ARE CAUSED BY ANY DEFECTS IN MATERIAL AND/OR WORKMANSHIP AND/OR DAMAGE OR DELAYS IN SHIPMENT. THIS WARRANTY IS EXPRESSLY IN LIEU OF ANY OTHER EXPRESS OR IMPLIED WARRANTY, INCLUDING ANY WARRANTY OF MERCHANTABILITY OR FITNESS FOR A PARTICULAR PURPOSE.**

No rights extended under this warranty shall be assigned to any other person, whether by operation of law or otherwise, without our prior written approval.

CRANE®

A Crane Co. Company

PUMPS & SYSTEMS

420 Third Street
Piqua, Ohio 45356
Phone: (937) 778-8947
Fax: (937) 773-7157
www.cranepumps.com

83 West Drive, Bramton
Ontario, Canada L6T 2J6
Phone: (905) 457-6223
Fax: (905) 457-2650

START-UP REPORT FOR SUBMERSIBLE PUMPS

This form is designed to provide assurance that customer service and a quality product are the number one priority with Crane Pumps & Systems, Inc (CP&S). Please fill out the following questions as completely and accurate as possible. When complete, mail this form to:

In U.S.A Send To:
Crane Pumps & Systems, Inc
Attn: Warranty Service Group
420 Third Street
Piqua, Ohio 45356

In Canada Send To:
Crane Pumps & Systems, Inc.
Attn: Service Manager
83 West Drive, Brampton
Ontario, Canada L6T 2J6

REPORTS THAT ARE NOT RETURNED CAN DELAY OR VOID WARRANTY.

Pump Owner's Name: _____

Address: _____

Location of Installation _____

Person in Charge _____ Phone _____

Purchased From (Crane Pumps & Systems Representative/Distributor) _____

Pump Model _____ Serial No. _____

Part Number _____

Voltage _____ Phase _____ Hertz _____ Horespower _____

Rotation: Direction of impeller rotation (Use C/W for clockwise, CC/W for counter-clockwise) _____

Method used to check rotation (viewed from bottom) _____

Does impeller turn freely by hand: Yes _____ No _____

Condition of equipment Good _____ Fair _____ Poor _____

Condition of cable jacket Good _____ Fair _____ Poor _____

Resistance of cable jacket Good _____ Fair _____ Poor _____

Resistance of cable and pump motor (measured at pump control)

Red-Black _____ Ohms, Red-White _____ Ohms, White-Black _____ Ohms

Resistance of Ground Circuit between Control Panel and outside of pump _____ Ohms

MEG Ohms check of insulation:

Red to Ground _____ White to Ground _____ Black to Ground _____

Condition of equipment at Start-Up: Dry _____ Wet _____ Muddy _____

Was Equipment Stored? _____ Length of Storage _____

Describe station layout _____

Liquid being pumped _____

Debris in bottom of station? _____

Was debris removed in your presence? _____

Are guide rails exactly vertical? _____

Is BAF stationary installed level? _____

Liquid level controls: Model _____

Are level controls installed away from turbulence? _____

Operation Check:

Tip lowest float (Stop Float), All pumps should remain off.

Tip second float (and Stop Float), one pump comes On.

Tip third float (and Stop Float), both pumps on (alarm on simplex).

Tip fourth float (and Stop Float), high level alarm on (omit on simplex).

If not CP&S level controls, describe type of controls _____

Does liquid level ever drop below volute top? _____

CP&S control panel part no. and brand _____
Number of pumps operated by control panel _____

NOTE: At no time should holes be made in top of control panel, unless proper sealing devices are utilized.

Control panel manufactured by others _____

Company name _____

Model number _____

Short circuit protection _____ Type _____

Number and size of short circuit device(s) _____ Amp rating _____

Overload type _____ Size _____ Amp rating _____

Do protection devices comply with pump and motor Amp rating? _____

Are all connections tight? _____

Is the interior of the panel dry? _____

ELECTRICAL READINGS:

Single Phase:

Voltage supply at panel line connection, Pump Off, L1, L2 _____

Voltage supply at panel line connection, Pump On, L1, L2 _____

Amperage: Load connection, Pump On L1 _____ L2 _____

Three Phase:

Voltage supply at panel line connection, Pump Off, L1 - L2 _____ L2 - L3 _____ L3 - L1 _____

Voltage supply at panel line connection, Pump On, L1 - L2 _____ L2 - L3 _____ L3 - L1 _____

Amperage: Load connection, Pump On L1 _____ L2 _____ L3 _____

FINAL CHECK:

Is pump seated on discharge properly? _____ Check for leaks? _____

Does check valve(s) operate properly? _____

Flow, Does station appear to operate at proper rate? _____ Pump down time _____

Noise level: High _____ Medium _____ Low _____

Comments: _____

Equipment difficulties during start-up: _____

MANUALS:

Has operator received pump instructions and parts manual? _____

Has operator received electrical control panel diagram? _____

Has operator been briefed on Warranty? _____

Address of local CP&S Representative/Distributor: _____

I have received the above information (Name of Operator) _____

Name of Company _____

Date: _____

I Certify this report to be accurate (Name of Start-Up person) _____

Employed By: _____ Date: _____

Date and time of Start-Up _____

Present at Start-Up

() Engineer: _____ () Operator: _____

() Contactor: _____ () Other: _____

To be filled out by factory:

Start-Up form checked by: _____ Date warranty registration mailed: _____

IMPORTANT!
WARRANTY REGISTRATION

Your product is covered by the enclosed Warranty.
Complete the Warranty Registration Form and return to
Crane Pumps & Systems, Inc. Warranty Service Group

If you have a claim under the provision of the warranty, contact your local
Crane Pumps & Systems, Inc. Distributor.

FOLD HERE AND TAPE, DO NOT STAPLE

.....

**** IMPORTANT! ****

WARRANTY REGISTRATION

CUSTOMER'S NAME _____ DATE INSTALLED _____

ADDRESS _____

CITY _____ STATE _____ ZIP _____

PHONE # _____ FAX # _____

DEALER'S NAME _____

CITY _____ STATE _____ ZIP _____

MODEL NO. _____ SERIAL NO. _____

PART NO. _____ BRAND _____

FOLD HERE AND TAPE, DO NOT STAPLE

PLACE
STAMP
HERE

CRANE PUMPS & SYSTEMS, INC.
WARRANTY SERVICE GROUP
420 THIRD STREET
PIQUA, OHIO
45356 - U.S.A.

Free Manuals Download Website

<http://myh66.com>

<http://usermanuals.us>

<http://www.somanuals.com>

<http://www.4manuals.cc>

<http://www.manual-lib.com>

<http://www.404manual.com>

<http://www.luxmanual.com>

<http://aubethermostatmanual.com>

Golf course search by state

<http://golfingnear.com>

Email search by domain

<http://emailbydomain.com>

Auto manuals search

<http://auto.somanuals.com>

TV manuals search

<http://tv.somanuals.com>