



## **Catalyst 4500 E-Series Switches Installation Guide**

November 2007

### **Americas Headquarters**

Cisco Systems, Inc.  
170 West Tasman Drive  
San Jose, CA 95134-1706  
USA  
<http://www.cisco.com>  
Tel: 408 526-4000  
800 553-NETS (6387)  
Fax: 408 527-0883

Text Part Number: OL-13972-01

THE SPECIFICATIONS AND INFORMATION REGARDING THE PRODUCTS IN THIS MANUAL ARE SUBJECT TO CHANGE WITHOUT NOTICE. ALL STATEMENTS, INFORMATION, AND RECOMMENDATIONS IN THIS MANUAL ARE BELIEVED TO BE ACCURATE BUT ARE PRESENTED WITHOUT WARRANTY OF ANY KIND, EXPRESS OR IMPLIED. USERS MUST TAKE FULL RESPONSIBILITY FOR THEIR APPLICATION OF ANY PRODUCTS.

THE SOFTWARE LICENSE AND LIMITED WARRANTY FOR THE ACCOMPANYING PRODUCT ARE SET FORTH IN THE INFORMATION PACKET THAT SHIPPED WITH THE PRODUCT AND ARE INCORPORATED HEREIN BY THIS REFERENCE. IF YOU ARE UNABLE TO LOCATE THE SOFTWARE LICENSE OR LIMITED WARRANTY, CONTACT YOUR CISCO REPRESENTATIVE FOR A COPY.

The following information is for FCC compliance of Class A devices: This equipment has been tested and found to comply with the limits for a Class A digital device, pursuant to part 15 of the FCC rules. These limits are designed to provide reasonable protection against harmful interference when the equipment is operated in a commercial environment. This equipment generates, uses, and can radiate radio-frequency energy and, if not installed and used in accordance with the instruction manual, may cause harmful interference to radio communications. Operation of this equipment in a residential area is likely to cause harmful interference, in which case users will be required to correct the interference at their own expense.

The following information is for FCC compliance of Class B devices: The equipment described in this manual generates and may radiate radio-frequency energy. If it is not installed in accordance with Cisco's installation instructions, it may cause interference with radio and television reception. This equipment has been tested and found to comply with the limits for a Class B digital device in accordance with the specifications in part 15 of the FCC rules. These specifications are designed to provide reasonable protection against such interference in a residential installation. However, there is no guarantee that interference will not occur in a particular installation.

Modifying the equipment without Cisco's written authorization may result in the equipment no longer complying with FCC requirements for Class A or Class B digital devices. In that event, your right to use the equipment may be limited by FCC regulations, and you may be required to correct any interference to radio or television communications at your own expense.

You can determine whether your equipment is causing interference by turning it off. If the interference stops, it was probably caused by the Cisco equipment or one of its peripheral devices. If the equipment causes interference to radio or television reception, try to correct the interference by using one or more of the following measures:

- Turn the television or radio antenna until the interference stops.
- Move the equipment to one side or the other of the television or radio.
- Move the equipment farther away from the television or radio.
- Plug the equipment into an outlet that is on a different circuit from the television or radio. (That is, make certain the equipment and the television or radio are on circuits controlled by different circuit breakers or fuses.)

Modifications to this product not authorized by Cisco Systems, Inc. could void the FCC approval and negate your authority to operate the product.

The Cisco implementation of TCP header compression is an adaptation of a program developed by the University of California, Berkeley (UCB) as part of UCB's public domain version of the UNIX operating system. All rights reserved. Copyright © 1981, Regents of the University of California.

NOTWITHSTANDING ANY OTHER WARRANTY HEREIN, ALL DOCUMENT FILES AND SOFTWARE OF THESE SUPPLIERS ARE PROVIDED "AS IS" WITH ALL FAULTS. CISCO AND THE ABOVE-NAMED SUPPLIERS DISCLAIM ALL WARRANTIES, EXPRESSED OR IMPLIED, INCLUDING, WITHOUT LIMITATION, THOSE OF MERCHANTABILITY, FITNESS FOR A PARTICULAR PURPOSE AND NONINFRINGEMENT OR ARISING FROM A COURSE OF DEALING, USAGE, OR TRADE PRACTICE.

IN NO EVENT SHALL CISCO OR ITS SUPPLIERS BE LIABLE FOR ANY INDIRECT, SPECIAL, CONSEQUENTIAL, OR INCIDENTAL DAMAGES, INCLUDING, WITHOUT LIMITATION, LOST PROFITS OR LOSS OR DAMAGE TO DATA ARISING OUT OF THE USE OR INABILITY TO USE THIS MANUAL, EVEN IF CISCO OR ITS SUPPLIERS HAVE BEEN ADVISED OF THE POSSIBILITY OF SUCH DAMAGES.

CCVP, the Cisco logo, and Welcome to the Human Network are trademarks of Cisco Systems, Inc.; Changing the Way We Work, Live, Play, and Learn is a service mark of Cisco Systems, Inc.; and Access Registrar, Aironet, Catalyst, CCDA, CCDP, CCIE, CCIP, CCNA, CCNP, CCSP, Cisco, the Cisco Certified Internetwork Expert logo, Cisco IOS, Cisco Press, Cisco Systems, Cisco Systems Capital, the Cisco Systems logo, Cisco Unity, Enterprise/Solver, EtherChannel, EtherFast, EtherSwitch, Fast Step, Follow Me Browsing, FormShare, GigaDrive, HomeLink, Internet Quotient, IOS, iPhone, IP/TV, iQ Expertise, the iQ logo, iQ Net Readiness Scorecard, iQuick Study, LightStream, Linksys, MeetingPlace, MGX, Networkers, Networking Academy, Network Registrar, PIX, ProConnect, ScriptShare, SMARTnet, StackWise, The Fastest Way to Increase Your Internet Quotient, and TransPath are registered trademarks of Cisco Systems, Inc. and/or its affiliates in the United States and certain other countries.

All other trademarks mentioned in this document or Website are the property of their respective owners. The use of the word partner does not imply a partnership relationship between Cisco and any other company. (0711R)

*Catalyst 4500 E-Series Switches Installation Guide*  
Copyright © 2007 Cisco Systems, Inc. All rights reserved.



## CONTENTS

### Preface vii

- Audience vii
- Organization vii
- Related Documentation viii
- Conventions viii
- Obtaining Documentation and Submitting a Service Request xv

---

### CHAPTER 1

### Product Overview 1-1

- Switch Features 1-1
  - Power Redundancy 1-1
  - Catalyst 4503-E Switch Features 1-2
  - Catalyst 4506-E Switch Features 1-5
  - Supervisor Engine Redundancy 1-8
  - Catalyst 4507R-E Switch Features 1-9
  - Catalyst 4510R-E Switch Features 1-13
- Supervisor Engines 1-16
  - LEDs 1-22
  - Gigabit Ethernet Uplink Ports 1-22
  - 10-Gigabit Ethernet Uplink Ports 1-23
  - SFP Ports 1-23
  - 10/100BASE-T Management Port 1-23
  - CONSOLE Port 1-23
  - RESET Button 1-24
  - Compact Flash Slot 1-24
- Fan Assembly 1-24
- Power Supplies 1-25
  - Power Supply LEDs 1-28
  - Power Supply Fan 1-28
  - Load-Sharing Feature 1-28
  - Environmental Monitoring Feature 1-29
  - 1400 W DC Triple-input Power Supply Operational Modes 1-29
- System Architecture 1-31
  - Power Flow 1-32
    - Power over Ethernet 1-32

Management Flow 1-35  
 Switching Traffic Flow 1-36

**CHAPTER 2**

**Preparing for Installation 2-1**

Electrostatic Discharge 2-2  
     Preventing Electrostatic Discharge Damage 2-2  
 Site Power Requirements and Heat Dissipation 2-3  
 Power Connection Guidelines for AC-Powered Systems 2-3  
 Power Connection Guidelines for DC-Powered Systems 2-9  
     Calculating DC Input Current 2-9  
 Ventilation 2-10  
     Calculating System Heat Dissipation 2-11  
 Site-Planning Checklist 2-11

**CHAPTER 3**

**Installing the Switch in a Rack 3-1**

Checking the Shipping Container Contents 3-1  
 Rack-Mounting the Switch 3-2  
     Required Installation Tools 3-2  
     Rack-Mounting Catalyst 4500 E-series Switches 3-3  
 System Ground Connection Guidelines 3-5  
     Parts and Required Tools 3-6  
     Connecting System Ground and Power 3-6

**CHAPTER 4**

**Removing and Replacing FRUs 4-1**

Removing and Replacing the Power Supply 4-2  
     Required Tools 4-4  
     Removing an AC-Input Power Supply 4-4  
     Installing an AC-Input Power Supply 4-6  
     Removing a DC-Input Power Supply 4-8  
         Required Tools 4-8  
         Removal Procedure 4-8  
     Installing a DC-Input Power Supply 4-11  
         Required Tools 4-11  
         Installation Procedure 4-12  
 Removing and Replacing the Chassis Fan Assembly 4-13  
     Required Tools 4-13  
     Removing the Fan Assembly 4-13  
     Installing the Fan Assembly 4-14



Verifying the Installation	4-15
Replacing Backplane Modules	4-15
Verify the New Modules	4-18
Supervisor Memory Upgrade	4-19
Tools and Equipment Needed	4-19
Removing Memory	4-19
Installing SDRAM MiniDIMMs	4-21

**CHAPTER 5****Troubleshooting 5-1**

System Boot Verification	5-2
Using LEDs to Identify Startup Problems	5-2
System Messages	5-4
Troubleshooting with Software	5-4
Troubleshooting the Power Supply	5-4
System Messages and Power Problems	5-5
Useful CLI Commands	5-5
Power Supply Mixing	5-6
Troubleshooting the Fan Assembly	5-6
System Messages and Fan Problems	5-7
Useful CLI Commands	5-7
Troubleshooting Backplane Modules	5-7
Troubleshooting Switching Modules	5-8
System Messages and Switching Modules	5-9
Useful CLI Commands	5-9
Troubleshooting Supervisor Engines	5-10
System Messages and Supervisor Engines	5-10
Useful CLI Commands	5-12
Standby Supervisor Engine Problems	5-12
Switch Self-reset	5-13
Ports 1/2 and 2/2 Do Not Function	5-13
Packet Loss	5-13
Some Problems and Solutions	5-14
Module Not Online	5-14
Interface Problems	5-15
Workstation Is Unable to Log In to the Network	5-15
NIC Compatibility Issues	5-16
Interface Is in Errdisable	5-16
Faulty Supervisor Engine	5-16

Boot Problems **5-17**  
 Contacting the Cisco Technical Assistance Center **5-18**  
 Serial Numbers **5-19**

**APPENDIX A**

**Specifications A-1**

Catalyst 4503-E Switch Specifications **A-1**  
 Catalyst 4506-E Switch Specifications **A-2**  
 Catalyst 4507R-E Switch Specifications **A-3**  
 Catalyst 4510R-E Switch Specifications **A-5**  
 Catalyst 4500 Power Supplies **A-6**

**APPENDIX B**

**Repacking a Switch B-1**

**APPENDIX C**

**Initial Configuration for the Switch C-1**

Connecting to the Switch **C-2**  
 Starting the Terminal-Emulation Software **C-2**  
 Connecting to a Power Source **C-2**  
 Entering the Initial Configuration Information **C-3**  
     IP Settings **C-3**  
     Performing the Initial Configuration **C-3**

**APPENDIX D**

**Module Overview and Specifications D-1**

Catalyst 4500 Series Switches **D-1**  
 Catalyst 4500 E-Series Switches **D-1**  
 Supervisor Engines **D-1**  
     Front-Panel Components **D-3**  
     Ethernet Management Port **D-4**  
     Console Port **D-4**  
     Supervisor Memory **D-4**  
 Switching Modules **D-4**  
     WS-X4606-X2-E **D-5**  
     WS-X4648-RJ45V-E **D-5**  
     WS-X4648-RJ45V+E **D-6**  
     Switching Module LEDs **D-7**  
 Hot-Swapping Feature **D-8**

**INDEX**



## Preface

---

This preface describes the audience, organization, and conventions of the Catalyst 4500 E-Series Switches Installation Guide and provides information on how to obtain related documentation and technical assistance.

## Audience

Only trained and qualified service personnel (as defined in IEC 60950 and AS/NZS3260) should install, replace, or service the equipment.

## Organization

This guide is organized as follows:

Chapter	Title	Description
Chapter 1	Product Overview	Describes the hardware features, components, interfaces, and functionality of the Catalyst 4500 E-series switches.
Chapter 2	Preparing for Installation	Describes how to prepare your site for the installation of the switch.
Chapter 3	Installing the Switch in a Rack	Describes how to install the Catalyst 4500 E-series switches.
Chapter 4	Removing and Replacing FRUs	Describes how to remove and replace field-replaceable units (FRUs).
Chapter 5	Troubleshooting	Provides troubleshooting guidelines for the initial hardware installation and suggests steps to help isolate and resolve problems.
Appendix A	Specifications	Lists the cable and technical specifications of the Catalyst 4500 E-series switches.
Appendix B	Repacking a Switch	Provides instructions for repacking your Catalyst 4500 E-series switch in the event that you have to return it to the factory.

Chapter	Title	Description
Appendix C	Initial Configuration for the Switch	Provides a very minimal configuration. For full configuration of features and interfaces, refer to the software configuration guide for your software release.
Appendix D	Module Overview and Specifications	Provides specifications and other information about the Catalyst 4500 E-series switching modules.

## Related Documentation

Refer to the following documents for additional Catalyst 4500 series and Catalyst 4500 E-series information:

- *Catalyst 4500 Series Module Installation Guide* at [http://www.cisco.com/en/US/docs/switches/lan/catalyst4500/hardware/module/guide/mod\\_inst.html](http://www.cisco.com/en/US/docs/switches/lan/catalyst4500/hardware/module/guide/mod_inst.html) for information about individual switching modules and supervisors not discussed in this publication.
- *Regulatory Compliance and Safety Information for the Catalyst 4500 Series Switches* at [http://www.cisco.com/en/US/docs/switches/lan/catalyst4500/hardware/regulatory/compliance/78\\_13233.html](http://www.cisco.com/en/US/docs/switches/lan/catalyst4500/hardware/regulatory/compliance/78_13233.html)
- The release note appropriate to your software version. Release notes are at: [http://www.cisco.com/en/US/products/hw/switches/ps4324/prod\\_release\\_notes\\_list.html](http://www.cisco.com/en/US/products/hw/switches/ps4324/prod_release_notes_list.html)
- The software configuration guide appropriate to your software version. Software configuration guides are at: [http://www.cisco.com/en/US/products/hw/switches/ps4324/products\\_installation\\_and\\_configuration\\_guides\\_list.html](http://www.cisco.com/en/US/products/hw/switches/ps4324/products_installation_and_configuration_guides_list.html)
- The command reference appropriate to your software version. Command references are at: [http://www.cisco.com/en/US/products/hw/switches/ps4324/prod\\_command\\_reference\\_list.html](http://www.cisco.com/en/US/products/hw/switches/ps4324/prod_command_reference_list.html)
- The system message guide appropriate to your software version. System message guides are at: [http://www.cisco.com/en/US/products/hw/switches/ps4324/products\\_system\\_message\\_guides\\_list.html](http://www.cisco.com/en/US/products/hw/switches/ps4324/products_system_message_guides_list.html)
- There are a number of installation notes and technical tips available for this switch. The top level Catalyst 4500 and Catalyst 4500-E documentation and technical support page is at [http://www.cisco.com/en/US/products/hw/switches/ps4324/tsd\\_products\\_support\\_series\\_home.html](http://www.cisco.com/en/US/products/hw/switches/ps4324/tsd_products_support_series_home.html)

## Conventions

This document uses the following conventions:

Convention	Description
boldface font	Commands and keywords are in boldface.
italic font	Arguments for which you supply values are in italics.
[ ]	Elements in square brackets are optional.

Convention	Description
{ x  y  z }	Alternative keywords are grouped in braces and separated by vertical bars.
[ x  y  z ]	Optional alternative keywords are grouped in brackets and separated by vertical bars.
string	A nonquoted set of characters. Do not use quotation marks around the string, because the string will include the quotation marks.
screen font	Terminal sessions and information that the system displays are in screen font.
<b>boldface screen font</b>	Information that you must enter is shown in <b>boldface screen font</b> .
<i>italic screen font</i>	Arguments for which you supply values are in <i>italic screen font</i> .
Ctrl-	Ctrl- represents the key labeled Control- for example, the key combination Ctrl-D means to hold down the Control key while you press the D key.
< >	Characters that do not print, such as passwords, are shown within angle brackets.

Notes use the following conventions:



**Note**

Means *reader take note*. Notes contain helpful suggestions or references to material not covered in the publication.

Cautions use the following conventions:



**Caution**

Means reader be careful. In this situation, you might do something that could result in equipment damage or loss of data.

Warnings use the following conventions:



**Warning**

### **IMPORTANT SAFETY INSTRUCTIONS**

This warning symbol means danger. You are in a situation that could cause bodily injury. Before you work on any equipment, be aware of the hazards involved with electrical circuitry and be familiar with standard practices for preventing accidents. Use the statement number provided at the end of each warning to locate its translation in the translated safety warnings that accompanied this device. Statement 1071

### **SAVE THESE INSTRUCTIONS**

**Waarschuwing**

### **BELANGRIJKE VEILIGHEIDSINSTRUCTIES**

Dit waarschuwingssymbool betekent gevaar. U verkeert in een situatie die lichamelijk letsel kan veroorzaken. Voordat u aan enige apparatuur gaat werken, dient u zich bewust te zijn van de bij elektrische schakelingen betrokken risico's en dient u op de hoogte te zijn van de standaard praktijken om ongelukken te voorkomen. Gebruik het nummer van de verklaring onderaan de waarschuwing als u een vertaling van de waarschuwing die bij het apparaat wordt geleverd, wilt raadplegen.

### **BEWAAR DEZE INSTRUCTIES**

**Varoitus**

### **TÄRKEITÄ TURVALLISUUSOHJEITA**

Tämä varoitusmerkki merkitsee vaaraa. Tilanne voi aiheuttaa ruumiillisia vammoja. Ennen kuin käsittelet laitteistoa, huomioi sähköpiirien käsittelyyn liittyvät riskit ja tutustu onnettomuuksien yleisiin ehkäisytapoihin. Turvallisuusvaroitusten käännökset löytyvät laitteen mukana toimitettujen käännettyjen turvallisuusvaroitusten joukosta varoitusten lopussa näkyvien lausuntonumeroiden avulla.

### **SÄILYTÄ NÄMÄ OHJEET**

**Attention**

### **IMPORTANTES INFORMATIONS DE SÉCURITÉ**

Ce symbole d'avertissement indique un danger. Vous vous trouvez dans une situation pouvant entraîner des blessures ou des dommages corporels. Avant de travailler sur un équipement, soyez conscient des dangers liés aux circuits électriques et familiarisez-vous avec les procédures couramment utilisées pour éviter les accidents. Pour prendre connaissance des traductions des avertissements figurant dans les consignes de sécurité traduites qui accompagnent cet appareil, référez-vous au numéro de l'instruction situé à la fin de chaque avertissement.

### **CONSERVEZ CES INFORMATIONS**

**Warnung**

### **WICHTIGE SICHERHEITSHINWEISE**

Dieses Warnsymbol bedeutet Gefahr. Sie befinden sich in einer Situation, die zu Verletzungen führen kann. Machen Sie sich vor der Arbeit mit Geräten mit den Gefahren elektrischer Schaltungen und den üblichen Verfahren zur Vorbeugung vor Unfällen vertraut. Suchen Sie mit der am Ende jeder Warnung angegebenen Anweisungsnummer nach der jeweiligen Übersetzung in den übersetzten Sicherheitshinweisen, die zusammen mit diesem Gerät ausgeliefert wurden.

### **BEWAHREN SIE DIESE HINWEISE GUT AUF.**

**Avvertenza      IMPORTANTI ISTRUZIONI SULLA SICUREZZA**

Questo simbolo di avvertenza indica un pericolo. La situazione potrebbe causare infortuni alle persone. Prima di intervenire su qualsiasi apparecchiatura, occorre essere al corrente dei pericoli relativi ai circuiti elettrici e conoscere le procedure standard per la prevenzione di incidenti. Utilizzare il numero di istruzione presente alla fine di ciascuna avvertenza per individuare le traduzioni delle avvertenze riportate in questo documento.

**CONSERVARE QUESTE ISTRUZIONI****Advarsel      VIKTIGE SIKKERHETSINSTRUKSJONER**

Dette advarselssymbolet betyr fare. Du er i en situasjon som kan føre til skade på person. Før du begynner å arbeide med noe av utstyret, må du være oppmerksom på farene forbundet med elektriske kretser, og kjenne til standardprosedyrer for å forhindre ulykker. Bruk nummeret i slutten av hver advarsel for å finne oversettelsen i de oversatte sikkerhetsadvarslene som fulgte med denne enheten.

**TA VARE PÅ DISSE INSTRUKSJONENE****Aviso      INSTRUÇÕES IMPORTANTES DE SEGURANÇA**

Este símbolo de aviso significa perigo. Você está em uma situação que poderá ser causadora de lesões corporais. Antes de iniciar a utilização de qualquer equipamento, tenha conhecimento dos perigos envolvidos no manuseio de circuitos elétricos e familiarize-se com as práticas habituais de prevenção de acidentes. Utilize o número da instrução fornecido ao final de cada aviso para localizar sua tradução nos avisos de segurança traduzidos que acompanham este dispositivo.

**GUARDE ESTAS INSTRUÇÕES****¡Advertencia!      INSTRUCCIONES IMPORTANTES DE SEGURIDAD**

Este símbolo de aviso indica peligro. Existe riesgo para su integridad física. Antes de manipular cualquier equipo, considere los riesgos de la corriente eléctrica y familiarícese con los procedimientos estándar de prevención de accidentes. Al final de cada advertencia encontrará el número que le ayudará a encontrar el texto traducido en el apartado de traducciones que acompaña a este dispositivo.

**GUARDE ESTAS INSTRUCCIONES****Varning!      VIKTIGA SÄKERHETSANVISNINGAR**

Denna varningssignal signalerar fara. Du befinner dig i en situation som kan leda till personskada. Innan du utför arbete på någon utrustning måste du vara medveten om farorna med elkretsar och känna till vanliga förfaranden för att förebygga olyckor. Använd det nummer som finns i slutet av varje varning för att hitta dess översättning i de översatta säkerhetsvarningar som medföljer denna anordning.

**SPARA DESSA ANVISNINGAR**

**Figyelem FONTOS BIZTONSÁGI ELOÍRÁSOK**

**Ez a figyelmeztető jel veszélyre utal. Sérülésveszélyt rejtő helyzetben van. Mielott bármely berendezésen munkát végezte, legyen figyelemmel az elektromos áramkörök okozta kockázatokra, és ismerkedjen meg a szokásos balesetvédelmi eljárásokkal. A kiadványban szereplő figyelmeztetések fordítása a készülékhez mellékelte biztonsági figyelmeztetések között található; a fordítás az egyes figyelmeztetések végén látható szám alapján kereshető meg.**

**ORIZZE MEG EZEKET AZ UTASÍTÁSOKAT!****Предупреждение ВАЖНЫЕ ИНСТРУКЦИИ ПО СОБЛЮДЕНИЮ ТЕХНИКИ БЕЗОПАСНОСТИ**

**Этот символ предупреждения обозначает опасность. То есть имеет место ситуация, в которой следует опасаться телесных повреждений. Перед эксплуатацией оборудования выясните, каким опасностям может подвергаться пользователь при использовании электрических цепей, и ознакомьтесь с правилами техники безопасности для предотвращения возможных несчастных случаев. Воспользуйтесь номером заявления, приведенным в конце каждого предупреждения, чтобы найти его переведенный вариант в переводе предупреждений по безопасности, прилагаемом к данному устройству.**

**СОХРАНИТЕ ЭТИ ИНСТРУКЦИИ****警告 重要的安全性说明**

此警告符号代表危险。您正处于可能受到严重伤害的工作环境中。在您使用设备开始工作之前，必须充分意识到触电的危险，并熟练掌握防止事故发生的标准工作程序。请根据每项警告结尾提供的声明号码来找到此设备的安全性警告说明的翻译文本。

请保存这些安全性说明

**警告 安全上の重要な注意事項**

「危険」の意味です。人身事故を予防するための注意事項が記述されています。装置の取り扱い作業を行うときは、電気回路の危険性に注意し、一般的な事故防止策に留意してください。警告の各国語版は、各注意事項の番号を基に、装置に付属の「Translated Safety Warnings」を参照してください。

これらの注意事項を保管しておいてください。

**주의 중요 안전 지침**

이 경고 기호는 위험을 나타냅니다. 작업자가 신체 부상을 일으킬 수 있는 위험한 환경에 있습니다. 장비에 작업을 수행하기 전에 전기 회로와 관련된 위험을 숙지하고 표준 작업 관례를 숙지하여 사고를 방지하십시오. 각 경고의 마지막 부분에 있는 경고문 번호를 참조하여 이 장치와 함께 제공되는 번역된 안전 경고문에서 해당 번역문을 찾으십시오.

이 지시 사항을 보관하십시오.



**Aviso INSTRUÇÕES IMPORTANTES DE SEGURANÇA**

Este símbolo de aviso significa perigo. Você se encontra em uma situação em que há risco de lesões corporais. Antes de trabalhar com qualquer equipamento, esteja ciente dos riscos que envolvem os circuitos elétricos e familiarize-se com as práticas padrão de prevenção de acidentes. Use o número da declaração fornecido ao final de cada aviso para localizar sua tradução nos avisos de segurança traduzidos que acompanham o dispositivo.

**GUARDE ESTAS INSTRUÇÕES****Advarsel VIGTIGE SIKKERHEDSANVISNINGER**

Dette advarselssymbol betyder fare. Du befinder dig i en situation med risiko for legemeskadedigelse. Før du begynder arbejde på udstyr, skal du være opmærksom på de involverede risici, der er ved elektriske kredsløb, og du skal sætte dig ind i standardprocedurer til undgåelse af ulykker. Brug erklæringsnummeret efter hver advarsel for at finde oversættelsen i de oversatte advarsler, der fulgte med denne enhed.

**GEM DISSE ANVISNINGER****تحذير****إرشادات الأمان الهامة**

يوضح رمز التحذير هذا وجود خطر. وهذا يعني أنك متواجد في مكان قد ينتج عنه التعرض للإصابات. قبل بدء العمل، احذر مخاطر التعرض للصدمات الكهربائية وكن على علم بالإجراءات القياسية للحيلولة دون وقوع أي حوادث. استخدم رقم البيان الموجود في آخر كل تحذير لتحديد مكان ترجمته داخل تحذيرات الأمان المترجمة التي تأتي مع الجهاز. قم بحفظ هذه الإرشادات

**Upozorenje VAŽNE SIGURNOSNE NAPOMENE**

Ovaj simbol upozorenja predstavlja opasnost. Nalazite se u situaciji koja može prouzročiti tjelesne ozljede. Prije rada s bilo kojim uređajem, morate razumjeti opasnosti vezane uz električne sklopove, te biti upoznati sa standardnim načinima izbjegavanja nesreća. U prevedenim sigurnosnim upozorenjima, priloženima uz uređaj, možete prema broju koji se nalazi uz pojedino upozorenje pronaći i njegov prijevod.

**SAČUVAJTE OVE UPUTE****Upozornění DŮLEŽITÉ BEZPEČNOSTNÍ POKYNY**

Tento upozorňující symbol označuje nebezpečí. Jste v situaci, která by mohla způsobit nebezpečí úrazu. Před prací na jakémkoliv vybavení si uvědomte nebezpečí související s elektrickými obvody a seznamte se se standardními opatřeními pro předcházení úrazům. Podle čísla na konci každého upozornění vyhledejte jeho překlad v přeložených bezpečnostních upozorněních, která jsou přiložena k zařízení.

**USCHOVEJTE TYTO POKYNY**

Προειδοποίηση ΣΗΜΑΝΤΙΚΕΣ ΟΔΗΓΙΕΣ ΑΣΦΑΛΕΙΑΣ

Αυτό το προειδοποιητικό σύμβολο σημαίνει κίνδυνο. Βρίσκεστε σε κατάσταση που μπορεί να προκαλέσει τραυματισμό. Πριν εργαστείτε σε οποιοδήποτε εξοπλισμό, να έχετε υπόψη σας τους κινδύνους που σχετίζονται με τα ηλεκτρικά κυκλώματα και να έχετε εξοικειωθεί με τις συνήθεις πρακτικές για την αποφυγή ατυχημάτων. Χρησιμοποιήστε τον αριθμό δήλωσης που παρέχεται στο τέλος κάθε προειδοποίησης, για να εντοπίσετε τη μετάφρασή της στις μεταφρασμένες προειδοποιήσεις ασφαλείας που συνοδεύουν τη συσκευή.

ΦΥΛΑΞΤΕ ΑΥΤΕΣ ΤΙΣ ΟΔΗΓΙΕΣ

הזהרה

**הוראות בטיחות חשובות**

סימן הזהרה זה מסמל סכנה. אתה נמצא במצב העלול לגרום לפציעה. לפני שתעבוד עם ציוד כלשהו, עליך להיות מודע לסכנות הכרוכות במעגלים חשמליים ולהכיר את הנהלים המקובלים למניעת תאונות. השתמש במספר ההוראה המסופק בסופה של כל הזהרה כדי לאתר את התרגום באזהרות הבטיחות המתורגמות שמצורפות להתקן.

**שמור הוראות אלה**

Opomena

**ВАЖНИ БЕЗБЕДНОСНИ НАПАТСТВИЈА**

Симболот за предупредување значи опасност. Се наоѓате во ситуација што може да предизвика телесни повреди. Пред да работите со опремата, бидете свесни за ризикот што постои кај електричните кола и треба да ги познавате стандардните постапки за спречување на несреќни случаи. Искористете го бројот на изјавата што се наоѓа на крајот на секое предупредување за да го најдете неговиот период во преведените безбедносни предупредувања што се испорачани со уредот.

ЧУВАЈТЕ ГИ ОБИЕ НАПАТСТВИЈА

Ostrzeżenie

**WAŻNE INSTRUKCJE DOTYCZĄCE BEZPIECZEŃSTWA**

Ten symbol ostrzeżenia oznacza niebezpieczeństwo. Zachodzi sytuacja, która może powodować obrażenia ciała. Przed przystąpieniem do prac przy urządzeniach należy zapoznać się z zagrożeniami związanymi z układami elektrycznymi oraz ze standardowymi środkami zapobiegania wypadkom. Na końcu każdego ostrzeżenia podano numer, na podstawie którego można odszukać tłumaczenie tego ostrzeżenia w dołączonym do urządzenia dokumencie z tłumaczeniami ostrzeżeń.

**NINIEJSZE INSTRUKCJE NALEŻY ZACHOWAĆ**

Upozornenie

**DÔLEŽITÉ BEZPEČNOSTNÉ POKYNY**

Tento varovný symbol označuje nebezpečenstvo. Nachádzate sa v situácii s nebezpečenstvom úrazu. Pred prácou na akomkoľvek vybavení si uvedomte nebezpečenstvo súvisiace s elektrickými obvodmi a oboznámte sa so štandardnými opatreniami na predchádzanie úrazom. Podľa čísla na konci každého upozornenia vyhľadajte jeho preklad v preložených bezpečnostných upozorneniach, ktoré sú priložené k zariadeniu.

**USCHOVAJTE SI TENTO NÁVOD**

# Obtaining Documentation and Submitting a Service Request

For information on obtaining documentation, submitting a service request, and gathering additional information, see the monthly *What's New in Cisco Product Documentation*, which also lists all new and revised Cisco technical documentation, at:

<http://www.cisco.com/en/US/docs/general/whatsnew/whatsnew.html>

Subscribe to the *What's New in Cisco Product Documentation* as a Really Simple Syndication (RSS) feed and set content to be delivered directly to your desktop using a reader application. The RSS feeds are a free service and Cisco currently supports RSS version 2.0.





# CHAPTER 1

## Product Overview

---

This chapter provides an overview of the features and components of the Catalyst 4500 E-series switches. The Catalyst 4500 E-series switches are the Catalyst 4503-E switch, the Catalyst 4506-E switch, the Catalyst 4507R-E switch, and the Catalyst 4510R-E switch. The information is presented in these major sections:

- Switch Features, page 1-1
- Supervisor Engines, page 1-16
- Fan Assembly, page 1-24
- Power Supplies, page 1-25
- System Architecture, page 1-31

## Switch Features

The following sections describe the features of the Catalyst 4500 E-series switches:

- Power Redundancy, page 1-1
- Catalyst 4503-E Switch Features, page 1-2
- Catalyst 4506-E Switch Features, page 1-5
- Supervisor Engine Redundancy, page 1-8
- Catalyst 4507R-E Switch Features, page 1-9
- Catalyst 4510R-E Switch Features, page 1-13

## Power Redundancy

All Catalyst 4500-E switches offer 1+1 power redundancy, so that in the event of a power interruption the switch can still operate using power from another circuit. The power supplies can also run in a combined mode so that chassis can have power from both supplies at once. You will need to use the **power redundancy-mode** command to configure combined mode. Redundant mode is the default.

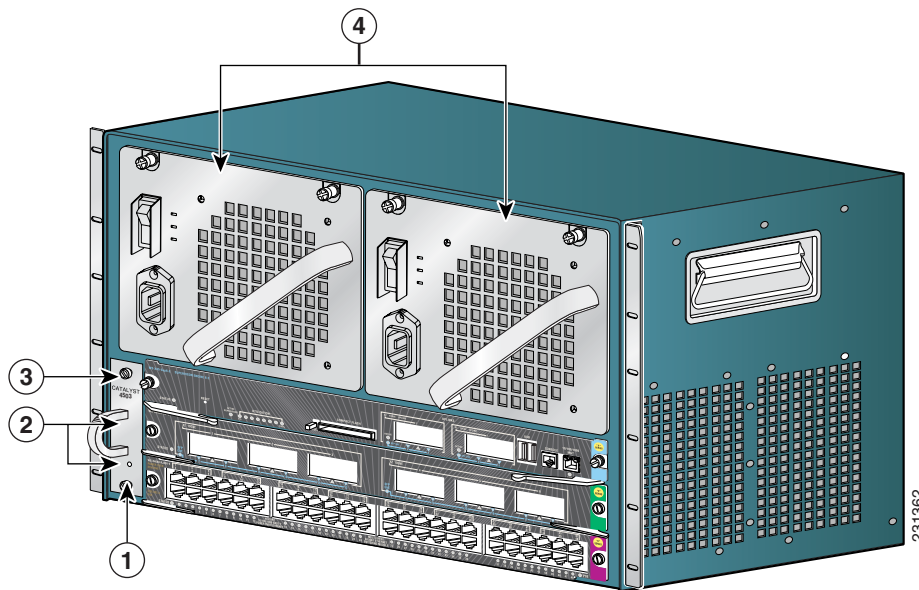
Catalyst 4500-E switches support power supply redundancy only between power supplies of equal wattage and type. A mix of power supplies is not supported. The second power supply recognized is placed into err-disable mode.

A more detailed discussion of power redundancy is in the *Environmental Monitoring and Power Management* chapter of the software configuration guide. Refer to the appropriate guide for your software release.

## Catalyst 4503-E Switch Features

The Catalyst 4503-E switch (see Figure 1-1) is a three-slot switch designed for high-performance high-density wiring closet applications.

**Figure 1-1 Catalyst 4503-E Switch (Front View)**



<b>1</b>	Fan assembly	<b>3</b>	Supervisor engine (Slot 1)
<b>2</b>	Switching modules (Slots 2 and 3)	<b>4</b>	Power supplies

The Catalyst 4503-E switch supports the Supervisor Engine II+, Supervisor Engine II+TS, Supervisor Engine II+10GE, Supervisor Engine IV, Supervisor Engine V, Supervisor Engine V-10GE, and Supervisor Engine 6-E. The supervisor engine has a nonblocking, full-duplex, switching fabric that provides connections between the supervisor engine and the switching modules. Some supervisor engines use SFP modules for Gigabit Ethernet connections, or X2 modules for 10-Gigabit Ethernet connections. Refer to the installation note for your supervisor engine for more details on these modules.

Slot 1 is reserved for the supervisor engine only, which provides switching, local and remote management, and switch-status monitoring. Slots 2 and 3 are available for switching modules. The chassis will support up to 24 Gbps per slot for slots 2 and 3, for a maximum of 116 ports with a Supervisor Engine II+TS, or 96 ports and 2 uplinks for other supervisors.

Table 1-1 describes the features of the Catalyst 4503-E switch.

**Table 1-1 Features of the Catalyst 4503 Switch**

Feature	Description
Ethernet speeds	<ul style="list-style-type: none"> <li>Ethernet (10BASE-T) interface to workstations and repeaters</li> <li>Fast Ethernet (100BASE-T) interface to workstations, servers, switches, and routers</li> </ul> <p><b>Note</b> Autonegotiation of link speed on each 10/100 port allows migration to 100BASE-T from a 10BASE-T installed base.</p> <ul style="list-style-type: none"> <li>Gigabit Ethernet (1000BASE-T and 1000BASE-X) interfaces for backbone interconnection of high-performance workstations, servers, switches and routers</li> <li>10-Gigabit Ethernet interfaces for backbone interconnection of high-performance switches and routers</li> </ul>
Standard equipment	<ul style="list-style-type: none"> <li>Three-slot modular chassis with one slot reserved for a supervisor engine and two slots for switching modules</li> <li>One hot-swappable fan assembly</li> <li>Two power supply bays</li> </ul>
Power supplies	<ul style="list-style-type: none"> <li>Supports a 1000 W, 1300 W, 1400 W, 2800 W, or 4200W AC-input power supply or a 1400 W DC-input single input or triple-input power supply<sup>1</sup></li> <li>Optional redundant power supply</li> </ul>
Supervisor engine support	<ul style="list-style-type: none"> <li>Supports the WS-X4013+, WS-X4013+TS, WS-X4013+10GE, WS-X4515, WS-X4516, WS-X4516-10GE, and WS-X45-Sup6-E supervisor engines</li> <li>Holds the ASIC-based forwarding engine (data path) and the management processor and software (control path)</li> <li>Features interface monitoring, environmental status, and SNMP and console/Telnet interface</li> </ul> <p><b>Note</b> Packets are not forwarded while the module is removed; a system reboot occurs when a supervisor engine is reinserted.</p>
Switching module support	<ul style="list-style-type: none"> <li>24-port 10/100BASE-TX Fast Ethernet switching module (WS-X4124-RJ45)</li> <li>24-port 100BASE-FX Fast Ethernet switching module (WS-X4124-FX-MT)</li> <li>48-port 100BASE-FX Fast Ethernet switching module (WS-X4148-FX-MT)</li> <li>48-port 100BASE-LX10 Fast Ethernet switching module (WS-X4148-FE-LX-MT)</li> <li>48-port 10/100-Mbps Fast Ethernet switching module (WS-X4148-RJ)</li> <li>48-port 100BASE-BX10-D Fast Ethernet switching module (WS-X4148-FE-BD-LC)</li> <li>48-port 10/100-Mbps Fast Ethernet switching module (WS-X4148-RJ21)</li> </ul>

**Table 1-1** Features of the Catalyst 4503 Switch (continued)

Feature	Description
Switching module support (continued)	<ul style="list-style-type: none"> <li>• 48-port 100BASE-X Fast Ethernet switching module (WS-X4248-FE-SFP)</li> <li>• 24-port IEEE 802.3af-compliant PoE 10/100BASE-TX switching module (WS-X4224-RJ45V)</li> <li>• 48-port IEEE 802.3af compliant PoE 10/100BASE-TX RJ-45 switching module (WS-X4248-RJ45V)</li> <li>• 48 port IEEE 802.3af compliant PoE 10/100BASE-TX RJ-21 switching module (WS-X4248-RJ21V)</li> <li>• 32-port 10/100-Mbps Fast Ethernet plus 2-port Gigabit Ethernet switching module (WS-X4232-GB-RJ)</li> <li>• 32-port 10/100-Mbps Fast Ethernet plus 2-port 1000BASE-X Layer 3 Gigabit Ethernet routing module (WS-X4232-L3)</li> <li>• 32-port 10/100-Mbps Fast Ethernet switching module with modular uplink support (WS-X4232-RJ-XX) <ul style="list-style-type: none"> <li>– 4-port MT-RJ uplink module (WS-U4504-FX-MT) (optional)</li> </ul> </li> <li>• 2-port Gigabit Ethernet switching module (WS-X4302-GB)</li> <li>• 6-port 1000BASE-X Gigabit Ethernet switching module (WS-X4306-GB)</li> <li>• 6-port Gigabit Ethernet switching module (WS-X4506-GB-T)</li> <li>• 18-port Gigabit Ethernet switching module (WS-X4418-GB)</li> <li>• 24-port 10/100/1000BASE-T Gigabit Ethernet switching module (WS-X4424-GB-RJ45)</li> <li>• 48-port Gigabit Ethernet 1000 BASE LX (SPF) switching module (WS-X4448-GB-LX)</li> <li>• 48-port 10/100/1000BASE-T Gigabit Ethernet switching module (WS-X4448-GB-RJ45)</li> <li>• 24-port IEEE 802.3af-compliant PoE 10/100/1000BASE-T RJ-45 switching module (WS-X4524-GB-RJ45V)</li> </ul>
	<ul style="list-style-type: none"> <li>• 48-port 10/100/1000BASE-T Gigabit Ethernet switching module (WS-X4548-GB-RJ45)</li> <li>• 48-port Gigabit Ethernet switching module (WS-X4448-GB-SFP)</li> <li>• 48-port IEEE 802.3af compliant PoE 10/100/1000BASE-T Gigabit Ethernet switching module (WS-X4548-GB-RJ45V)</li> <li>• Backplane channel module (WS-X4019)</li> <li>• 6-port 10GbE X2 switching module (WS-X4606-X2-E)</li> <li>• 48-port 802.3af PoE 10/100/1000 RJ45 switching module (WS-X4648-RJ45V-E)</li> <li>• 48-port Premium PoE 10/100/1000 (RJ45) switching module (WS-X4648-RJ45V+E)</li> </ul>

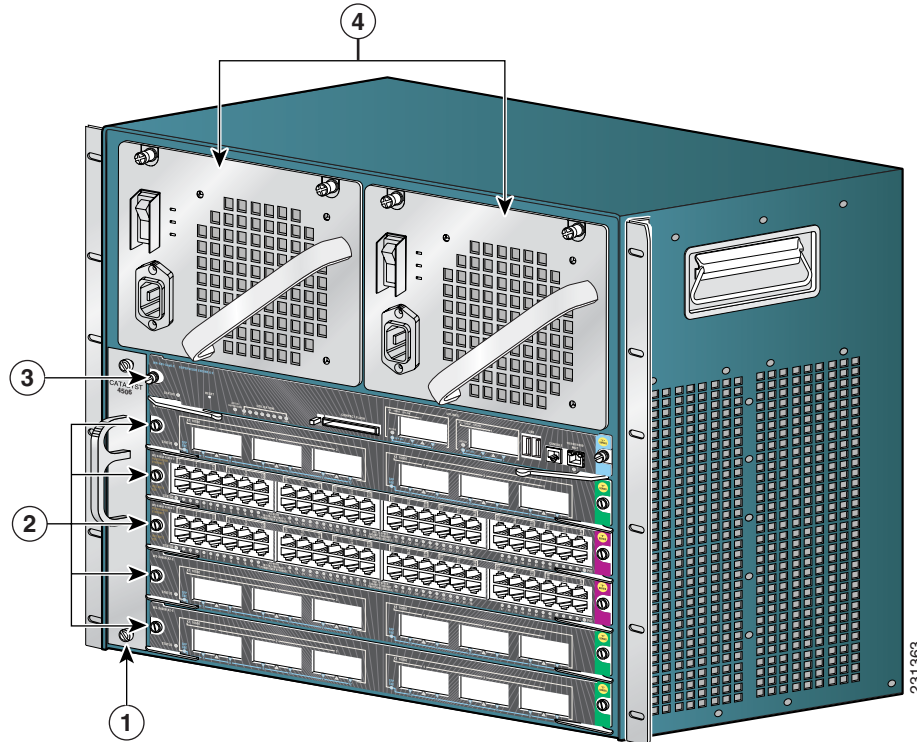
1. You will need to configure the 1400 W DC input current as appropriate for the model of switch. Refer to Appendix A, “Specifications.”



## Catalyst 4506-E Switch Features

The Catalyst 4506-E switch (see Figure 1-2) is a six-slot switch designed for high-performance high-density wiring closet applications.

**Figure 1-2 Catalyst 4506-E Switch (Front View)**



<b>1</b>	Fan assembly	<b>3</b>	Supervisor engine (Slot 1)
<b>2</b>	Switching modules (Slots 2 to 6)	<b>4</b>	Power supplies

The Catalyst 4506-E switch supports the Supervisor Engine II+, Supervisor Engine II+10GE, Supervisor Engine IV, Supervisor Engine V, Supervisor Engine V-10GE, and Supervisor Engine 6-E. The supervisor engine has a nonblocking, full-duplex, switching fabric that provides connections between the supervisor engine and the switching modules. Some supervisor engines use SFP modules for Gigabit Ethernet connections, or X2 modules for 10-Gigabit Ethernet connections. Refer to the installation note for your supervisor engine for more details on these modules.

Slot 1 is reserved for the supervisor engine only, which provides switching, local and remote management, and switch-status monitoring. Slots 2 through 6 are available for switching modules. The chassis will support up to 24 Gbps per slot for slots 2 through 6, for a maximum of 240 ports and 2 uplinks.

Table 1-2 describes the features of the Catalyst 4506-E switch.

**Table 1-2** Features of the Catalyst 4506-E Switch

Feature	Description
Ethernet speeds	<ul style="list-style-type: none"> <li>Ethernet (10BASE-T) interface to workstations and repeaters</li> <li>Fast Ethernet (100BASE-T) interface to workstations, servers, switches, and routers</li> </ul> <p><b>Note</b> Autonegotiation of link speed on each 10/100 port allows migration to 100BASE-T from a 10BASE-T installed base.</p> <ul style="list-style-type: none"> <li>Gigabit Ethernet (1000BASE-T and 1000BASE-X) interfaces for backbone interconnection of high-performance workstations, servers, switches and routers</li> <li>10-Gigabit Ethernet interfaces for backbone interconnection of high-performance switches and routers</li> </ul>
Standard equipment	<ul style="list-style-type: none"> <li>Six-slot modular chassis with one slot reserved for a supervisor engine and five slots for switching modules</li> <li>One hot-swappable fan assembly</li> <li>Two power supply bays</li> </ul>
Power supplies	<ul style="list-style-type: none"> <li>Supports a 1000 W, 1300 W, 1400 W, 2800 W, or 4200 W AC-input power supply or a 1400 W DC-input single or triple-input power supply<sup>1</sup></li> <li>Optional redundant power supply</li> </ul>
Supervisor engine support	<ul style="list-style-type: none"> <li>Supports the WS-X4013+, WS-X4515, WS-X4516, WS-X4516-10GE, and WS-X45-Sup6-E Supervisor Engines</li> <li>Holds the ASIC-based forwarding engine (data path) and the management processor and software (control path)</li> <li>Features interface monitoring, environmental status, and SNMP and console/Telnet interface</li> </ul> <p><b>Note</b> Packets are not forwarded while the module is removed; a system reboot occurs when a supervisor engine is reinserted.</p>
Switching module support	<ul style="list-style-type: none"> <li>24-port 10/100BASE-TX Fast Ethernet switching module (WS-X4124-RJ45)</li> <li>24-port 100BASE-FX Fast Ethernet switching module (WS-X4124-FX-MT)</li> <li>48-port 100BASE-FX Fast Ethernet switching module (WS-X4148-FX-MT)</li> <li>48-port 100BASE-LX10 Fast Ethernet switching module (WS-X4148-FE-LX-MT)</li> <li>48-port 10/100-Mbps Fast Ethernet switching module (WS-X4148-RJ)</li> <li>48-port 100BASE-BX10-D Fast Ethernet switching module (WS-X4148-FE-BD-LC)</li> </ul>

**Table 1-2** *Features of the Catalyst 4506-E Switch (continued)*

Feature	Description
Switching module support (continued)	<ul style="list-style-type: none"> <li>• 48-port 10/100-Mbps Fast Ethernet switching module (WS-X4148-RJ21)</li> <li>• 24-port IEEE 802.3af-compliant PoE 10/100BASE-TX switching module (WS-X4224-RJ45V)</li> <li>• 48-port IEEE 802.3af compliant PoE 10/100BASE-TX RJ-45 switching module (WS-X4248-RJ45V)</li> <li>• 48-port 100BASE-X Fast Ethernet switching module (WS-X4248-FE-SFP)</li> <li>• 48 port IEEE 802.3af compliant PoE 10/100BASE-TX RJ-21 switching module (WS-X4248-RJ21V)</li> <li>• 32-port 10/100-Mbps Fast Ethernet plus 2-port Gigabit Ethernet switching module (WS-X4232-GB-RJ)</li> <li>• 32-port 10/100-Mbps Fast Ethernet plus 2-port 1000BASE-X Layer 3 Gigabit Ethernet routing module (WS-X4232-L3)</li> <li>• 32-port 10/100-Mbps Fast Ethernet switching module with modular uplink support (WS-X4232-RJ-XX)</li> <li>• 2-port Gigabit Ethernet switching module (WS-X4302-GB)</li> <li>• 6-port 1000BASE-X Gigabit Ethernet switching module (WS-X4306-GB)</li> <li>• 6-port Gigabit Ethernet switching module (WS-X4506-GB-T)</li> <li>• 18-port Gigabit Ethernet switching module (WS-X4418-GB)</li> <li>• 24-port 10/100/1000BASE-T Gigabit Ethernet switching module (WS-X4424-GB-RJ45)</li> <li>• 48-port Gigabit Ethernet 1000 BASE LX (SPF) switching module (WS-X4448-GB-LX)</li> <li>• 48-port 10/100/1000BASE-T Gigabit Ethernet switching module (WS-X4448-GB-RJ45)</li> <li>• 24-port IEEE 802.3af-compliant PoE 10/100/1000BASE-T RJ-45 switching module (WS-X4524-GB-RJ45V)</li> <li>• 48-port 10/100/1000BASE-T Gigabit Ethernet switching module (WS-X4548-GB-RJ45)</li> <li>• 48-port Gigabit Ethernet switching module (WS-X4448-GB-SFP)</li> <li>• 48-port IEEE 802.3af compliant PoE 10/100/1000BASE-T Gigabit Ethernet switching module (WS-X4548-GB-RJ45V)</li> <li>• Backplane channel module (WS-X4019)</li> <li>• 6-port 10GbE X2 switching module (WS-X4606-X2-E)</li> <li>• 48-port 802.3af PoE 10/100/1000 RJ45 switching module (WS-X4648-RJ45V-E)</li> <li>• 48-port Premium PoE 10/100/1000 RJ45 switching module (WS-X4648-RJ45V+E)</li> </ul>

1. You will need to configure the 1400 W DC input current as appropriate for the model of switch. Refer to Appendix A, “Specifications.”

## Supervisor Engine Redundancy

The Catalyst 4507R-E and Catalyst 4510R-E switches support supervisor engine redundancy. Redundancy allows a second supervisor engine to take over if the active supervisor engine fails.

With supervisor engine redundancy enabled, if the active supervisor engine fails or if a manual switchover is performed, the redundant supervisor engine becomes the active supervisor engine. The redundant supervisor engine is automatically initialized with the startup configuration of the active supervisor engine. Depending on the configuration this shortens the switchover time from 30 seconds or longer in Route Processor Redundancy (RPR) mode, to less than a second in Stateful Switch Over (SSO) mode.

In addition to the reduced switchover time, supervisor engine redundancy supports these:

- Online insertion and removal (OIR) of the redundant supervisor engine  
Supervisor engine redundancy allows OIR of the redundant supervisor engine for maintenance. When the redundant supervisor engine is inserted, the active supervisor engine detects it. The redundant supervisor engine boots into a partially initialized state in RPR mode and a fully initialized state in SSO mode.
- Software upgrade  
Load the new image on the redundant supervisor engine and conduct a switchover. This minimizes downtime during software changes on the supervisor engine.

When power is first applied to a switch, the supervisor engine that boots first becomes the active supervisor engine and remains active until a switchover occurs.

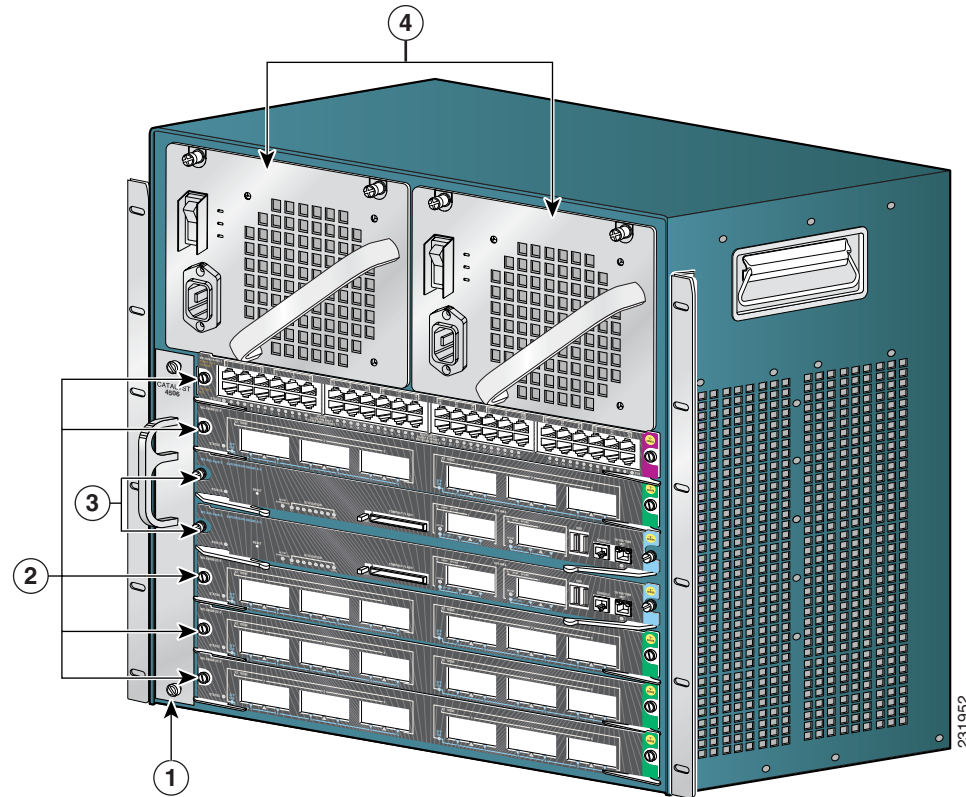
Redundancy requires that both supervisor engines in the chassis are of the same supervisor engine model, and that they use the same Cisco IOS software image.

For more detail about redundancy, refer to the *Configuring Supervisor Engine Redundancy Using RPR and SSO* chapter of the software configuration guide for your software release.

## Catalyst 4507R-E Switch Features

The Catalyst 4507R-E switch (see Figure 1-3) is a seven-slot switch designed for high-performance high-density wiring closet applications.

**Figure 1-3 Catalyst 4507R-E Switch (Front View)**



<b>1</b>	Fan Tray	<b>3</b>	Supervisor engines (primary in slot 3, secondary in slot 4)
<b>2</b>	Switching modules (slots 1, 2, 5, 6, 7)	<b>4</b>	Power supplies

The Catalyst 4507R-E switch supports the Supervisor Engine II+, Supervisor Engine IV, Supervisor Engine V, Supervisor Engine V-10GE, and Supervisor Engine 6-E. The supervisor engine has two Gigabit Ethernet ports and a nonblocking, full-duplex, switching fabric that provides connections between the supervisor engine and the switching modules. Some supervisor engines use SFP modules for Gigabit Ethernet connections or X2 modules for 10-Gigabit Ethernet connections. Refer to the installation note for your supervisor engine for more details on these modules.

Slot 3 is reserved for the supervisor engine only, which provides switching, local and remote management, and switch-status monitoring. Slot 4 is reserved for a redundant supervisor engine only. Slots 1, 2, 5, 6, and 7 are available for switching modules and provide 24 Gbps per slot for a maximum of 240 ports and 4 uplinks.

Table 1-3 describes the features of the Catalyst 4507R-E switch.

**Table 1-3**      **Features of the Catalyst 4507R-E Switch**

Feature	Description
Ethernet speeds	<ul style="list-style-type: none"> <li>• Ethernet (10BASE-T) interface to workstations and repeaters</li> <li>• Fast Ethernet (100BASE-T) interface to workstations, servers, switches, and routers</li> </ul> <p><b>Note</b>    Autonegotiation of link speed on each 10/100 port allows migration to 100BASE-T from a 10BASE-T installed base.</p> <ul style="list-style-type: none"> <li>• Gigabit Ethernet (1000BASE-T and 1000BASE-X) interfaces for backbone interconnection of high-performance switches and routers</li> <li>• 10-Gigabit Ethernet interfaces for backbone interconnection of high-performance switches and routers</li> </ul>
Standard equipment	<ul style="list-style-type: none"> <li>• Seven-slot modular chassis with one slot reserved for a supervisor engine, one slot reserved for a redundant supervisor engine, and five slots for switching modules</li> <li>• Two power supply bays</li> <li>• One hot-swappable fan assembly</li> </ul>
Power supplies	<ul style="list-style-type: none"> <li>• Can support a 1000 W, 1300 W, 1400 W, 2800 W, or 4200W AC-input power supply or a 1400 W DC-input single or triple-input power supply<sup>1</sup></li> <li>• Optional redundant power supply</li> </ul>
Supervisor engine support	<ul style="list-style-type: none"> <li>• Supports the WS-X4013+, WS-X4515, WS-X4516, WS-X4516-10GE, and WS-X45-Sup6-E Supervisor Engines</li> <li>• Holds the ASIC-based forwarding engine (data path) and the management processor and software (control path)</li> <li>• Features interface monitoring, environmental status, and SNMP and console/Telnet interface</li> </ul> <p><b>Note</b>    With a single supervisor, packets are not forwarded while the module is removed; a system reboot occurs when a supervisor engine is reinserted. In redundant systems, removing the active supervisor causes the standby supervisor to become active.</p>

**Table 1-3** *Features of the Catalyst 4507R-E Switch (continued)*

<b>Feature</b>	<b>Description</b>
Switching module support	<ul style="list-style-type: none"> <li>• 32-port 10/100-Mbps Fast Ethernet plus 2-port Gigabit Ethernet switching module (WS-X4232-GB-RJ)</li> <li>• 32-port 10/100-Mbps Fast Ethernet plus 2-port 1000BASE-X Layer 3 Gigabit Ethernet routing module (WS-X4232-L3)</li> <li>• 32-port 10/100-Mbps Fast Ethernet switching module with modular uplink support (WS-X4232-RJ-XX) <ul style="list-style-type: none"> <li>– 4-port MT-RJ uplink module (WS-U4504-FX-MT) (optional)</li> </ul> </li> <li>• 2-port Gigabit Ethernet switching module (WS-X4302-GB)</li> <li>• 24-port 10/100BASE-TX Fast Ethernet switching module (WS-X4124-RJ45)</li> <li>• 24-port 100BASE-FX Fast Ethernet switching module (WS-X4124-FX-MT)</li> <li>• 48-port 100BASE-FX Fast Ethernet switching module (WS-X4148-FX-MT)</li> <li>• 48-port 100BASE-LX10 Fast Ethernet switching module (WS-X4148-FE-LX-MT)</li> <li>• 48-port 10/100-Mbps Fast Ethernet switching module (WS-X4148-RJ)</li> <li>• 48-port 100BASE-BX10-D Fast Ethernet switching module (WS-X4148-FE-BD-LC)</li> <li>• 48-port 10/100-Mbps Fast Ethernet switching module (WS-X4148-RJ21)</li> <li>• 48-port 100BASE-X Fast Ethernet switching module (WS-X4248-FE-SFP)</li> </ul>

**Table 1-3** Features of the Catalyst 4507R-E Switch (continued)

Feature	Description
Switching module support (continued)	<ul style="list-style-type: none"> <li>• 24-port IEEE 802.3af-compliant PoE 10/100BASE-TX switching module (WS-X4224-RJ45V)</li> <li>• 48-port IEEE 802.3af compliant PoE 10/100BASE-TX RJ-45 switching module (WS-X4248-RJ45V)</li> <li>• 48 port IEEE 802.3af compliant PoE 10/100BASE-TX RJ-21 switching module (WS-X4248-RJ21V)</li> <li>• 6-port 1000BASE-X Gigabit Ethernet switching module (WS-X4306-GB)</li> <li>• 6-port Gigabit Ethernet switching module (WS-X4506-GB-T)</li> <li>• 18-port Gigabit Ethernet switching module (WS-X4418-GB)</li> <li>• 24-port 10/100/1000BASE-T Gigabit Ethernet switching module (WS-X4424-GB-RJ45)</li> <li>• 48-port Gigabit Ethernet 1000 BASE LX (SPF) switching module (WS-X4448-GB-LX)</li> <li>• 48-port 10/100/1000BASE-T Gigabit Ethernet switching module (WS-X4448-GB-RJ45)</li> <li>• 24-port IEEE 802.3af-compliant PoE 10/100/1000BASE-T RJ-45 switching module (WS-X4524-GB-RJ45V)</li> <li>• 48-port 10/100/1000BASE-T Gigabit Ethernet switching module (WS-X4548-GB-RJ45)</li> <li>• 48-port Gigabit Ethernet switching module (WS-X4448-GB-SFP)</li> <li>• 48-port IEEE 802.3af compliant PoE 10/100/1000BASE-T Gigabit Ethernet switching module (WS-X4548-GB-RJ45V)</li> <li>• 6-port 10GbE X2 switching module (WS-X4606-X2-E)</li> <li>• 48-port 802.3af PoE 10/100/1000 RJ45 switching module (WS-X4648-RJ45V-E)</li> <li>• 48-port Premium PoE 10/100/1000 RJ45 switching module (WS-X4648-RJ45V+E)</li> </ul>

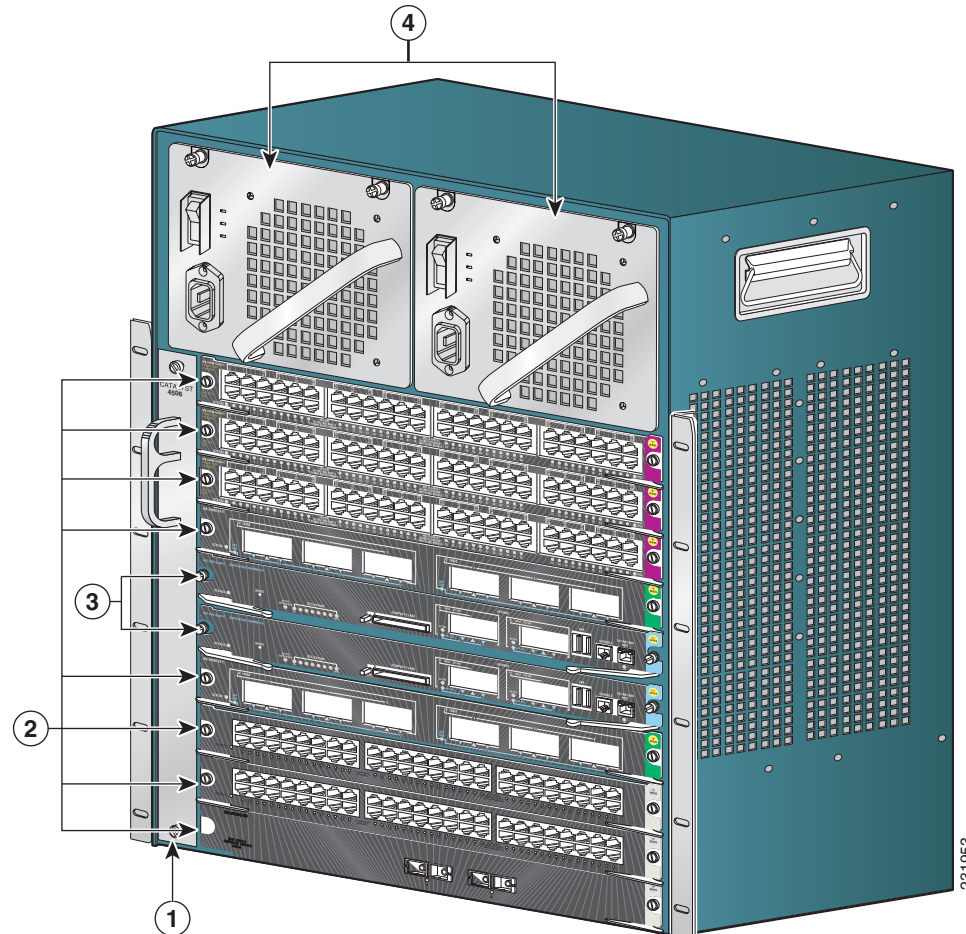
1. You will need to configure the 1400 W DC input current as appropriate for the model of switch. Refer to Appendix A, "Specifications."



## Catalyst 4510R-E Switch Features

The Catalyst 4510R-E switch (see Figure 1-4) is a ten-slot switch designed for high-performance high-density wiring closet applications.

**Figure 1-4 Catalyst 4510R-E Switch (Front View)**



<b>1</b>	Fan Tray	<b>3</b>	Supervisor engines (primary in slot 5, secondary in slot 6)
<b>2</b>	Switching modules (slots 1, 2, 3, 4, 7, 8, 9, 10)	<b>4</b>	Power supplies

The Catalyst 4510R-E switch supports the Supervisor Engine V, Supervisor Engine V-10GE, and Supervisor Engine 6-E. The supervisor engine has a nonblocking, full-duplex, switching fabric that provides connections between the supervisor engine and the switching modules. Some supervisor engines use SFP modules for Gigabit Ethernet connections, or X2 modules for 10 Gigabit Ethernet connections. Refer to the installation note for your supervisor engine for more details on these modules.

Slot 5 is reserved for the supervisor engine only, which provides switching, local and remote management, and switch-status monitoring. Slot 6 is reserved for a redundant supervisor engine only. Slots 1, 2, 3, 4, 7, 8, 9, and 10 are available for switching modules and provide up to 24 Gbps per slot

for a maximum of 384 ports and 4 uplinks. With a Supervisor Engine 6-E, slots 8 to 10 provide 6 Gbps per slot and all other slots provide 24 Gbps per slot. With a Supervisor Engine V or Supervisor Engine V-10GE, all slots are 6 Gbps and E-series switching modules can not be used.

Table 1-4 describes the features of the Catalyst 4510R-E switch.

**Table 1-4** Features of the Catalyst 4510R-E Switch

Feature	Description
Ethernet speeds	<ul style="list-style-type: none"> <li>Ethernet (10BASE-T) interface to workstations and repeaters</li> <li>Fast Ethernet (100BASE-T) interface to workstations, servers, switches, and routers</li> </ul> <p><b>Note</b> Autonegotiation of link speed on each 10/100 port allows migration to 100BASE-T from a 10BASE-T installed base.</p> <ul style="list-style-type: none"> <li>Gigabit Ethernet (1000BASE-T and 1000BASE-X) interfaces for backbone interconnection of high-performance switches and routers</li> <li>10-Gigabit Ethernet interfaces for backbone interconnection of high-performance switches and routers</li> </ul>
Standard equipment	<ul style="list-style-type: none"> <li>Ten-slot modular chassis with one slot reserved for a supervisor engine, one slot reserved for a redundant supervisor engine, and eight slots for switching modules</li> <li>Two power supply bays</li> <li>One hot-swappable fan assembly</li> </ul>
Power supplies	<ul style="list-style-type: none"> <li>Can support a 1400 W, 2800 W, or 4200 W AC-input power supply or a 1400 W DC-input single or triple-input power supply<sup>1,2</sup></li> <li>Optional redundant power supply</li> </ul>
Supervisor engine support	<ul style="list-style-type: none"> <li>Supports the WS-X4516, WS-X4516-10GE, and WS-X45-Sup6-E Supervisor Engines</li> <li>Holds the ASIC-based forwarding engine (data path) and the management processor and software (control path)</li> <li>Features interface monitoring, environmental status, and SNMP and console/Telnet interface</li> </ul> <p><b>Note</b> With a single supervisor, packets are not forwarded while the module is removed; a system reboot occurs when a supervisor engine is reinserted. In redundant systems, removing the active supervisor causes the standby supervisor to become active.</p>

**Table 1-4** *Features of the Catalyst 4510R-E Switch (continued)*

<b>Feature</b>	<b>Description</b>
Switching module support	<ul style="list-style-type: none"> <li>• 24-port 10/100BASE-TX Fast Ethernet switching module (WS-X4124-RJ45)</li> <li>• 24-port 100BASE-FX Fast Ethernet switching module (WS-X4124-FX-MT)</li> <li>• 48-port 100BASE-FX Fast Ethernet switching module (WS-X4148-FX-MT)</li> <li>• 48-port 100BASE-LX10 Fast Ethernet switching module (WS-X4148-FE-LX-MT)</li> <li>• 48-port 10/100-Mbps Fast Ethernet switching module (WS-X4148-RJ)</li> <li>• 48-port 100BASE-BX10-D Fast Ethernet switching module (WS-X4148-FE-BD-LC)</li> <li>• 48-port 10/100-Mbps Fast Ethernet switching module (WS-X4148-RJ21)</li> <li>• 24-port IEEE 802.3af-compliant PoE 10/100BASE-TX switching module (WS-X4224-RJ45V)</li> <li>• 48-port IEEE 802.3af compliant PoE 10/100BASE-TX RJ-45 switching module (WS-X4248-RJ45V)</li> <li>• 48-port 100BASE-X Fast Ethernet switching module (WS-X4248-FE-SFP)</li> <li>• 48 port IEEE 802.3af compliant PoE 10/100BASE-TX RJ-21 switching module (WS-X4248-RJ21V)</li> <li>• 32-port 10/100-Mbps Fast Ethernet plus 2-port Gigabit Ethernet switching module (WS-X4232-GB-RJ)</li> </ul>

**Table 1-4 Features of the Catalyst 4510R-E Switch (continued)**

Feature	Description
Switching module support (continued)	<ul style="list-style-type: none"> <li>• 32-port 10/100-Mbps Fast Ethernet plus 2-port 1000BASE-X Layer 3 Gigabit Ethernet routing module (WS-X4232-L3)</li> <li>• 32-port 10/100-Mbps Fast Ethernet switching module with modular uplink support (WS-X4232-RJ-XX) <ul style="list-style-type: none"> <li>– 4-port MT-RJ uplink module (WS-U4504-FX-MT) (optional)</li> </ul> </li> <li>• 2-port Gigabit Ethernet switching module (WS-X4302-GB)</li> <li>• 6-port 1000BASE-X Gigabit Ethernet switching module (WS-X4306-GB)</li> <li>• 6-port Gigabit Ethernet switching module (WS-X4506-GB-T)</li> <li>• 18-port Gigabit Ethernet switching module (WS-X4418-GB)</li> <li>• 24-port 10/100/1000BASE-T Gigabit Ethernet switching module (WS-X4424-GB-RJ45)</li> <li>• 48-port Gigabit Ethernet 1000 BASE LX (SPF) switching module (WS-X4448-GB-LX)</li> <li>• 48-port 10/100/1000BASE-T Gigabit Ethernet switching module (WS-X4448-GB-RJ45)</li> <li>• 24-port IEEE 802.3af-compliant PoE 10/100/1000BASE-T RJ-45 switching module (WS-X4524-GB-RJ45V)</li> <li>• 48-port 10/100/1000BASE-T Gigabit Ethernet switching module (WS-X4548-GB-RJ45)</li> <li>• 48-port Gigabit Ethernet switching module (WS-X4448-GB-SFP)</li> <li>• 48-port IEEE 802.3af compliant PoE 10/100/1000BASE-T Gigabit Ethernet switching module (WS-X4548-GB-RJ45V)</li> <li>• 6-port 10GbE X2 switching module (WS-X4606-X2-E)</li> <li>• 48-port 802.3af PoE 10/100/1000 RJ45 switching module (WS-X4648-RJ45V-E)</li> <li>• 48-port Premium PoE 10/100/1000 RJ45 switching module (WS-X4648-RJ45V+E)</li> </ul>

1. You will need to configure the 1400 W DC input current as appropriate for the model of switch. Refer to Appendix A, “Specifications.”
2. 1000W AC and 1300W AC power supplies will fit and function; however, power management is cautioned and only some configurations will have adequate power. Please refer to the Cisco Power Calculator at <http://tools.cisco.com/cpc/> before configuring these power supplies.

## Supervisor Engines

The following supervisor engines are available for the Catalyst 4500 series and Catalyst 4500 E-series switches:

- Supervisor Engine II-Plus (WS-X4013+) (Figure 1-5)
- Supervisor Engine II-Plus TS (WS-X4013+TS) (Figure 1-6)
- Supervisor Engine II-Plus 10GE (WS-X4013+10GE) (Figure 1-7)

- Supervisor Engine IV (WS-X4515) (Figure 1-8)
- Supervisor Engine V (WS-X4516) (Figure 1-9)
- Supervisor Engine V-10GE (WS-X4516-10GE) (Figure 1-10)
- Supervisor Engine 6-E (WS-X45-Sup6-E) (Figure 1-11)

**Note**

If you move a supervisor engine from a Catalyst 4500 series chassis to a Catalyst 4500-E chassis it must use Cisco IOS Release 12.2(37)SG or later. Refer to the release note for software upgrade procedures if needed:

[http://www.cisco.com/en/US/products/hw/switches/ps4324/prod\\_release\\_note09186a0080758ff3.html#wp305142](http://www.cisco.com/en/US/products/hw/switches/ps4324/prod_release_note09186a0080758ff3.html#wp305142)

The Catalyst 4500 series and Catalyst 4500 E-series supervisor engines have the following features:

**Table 1-5 Supervisor Engine Features**

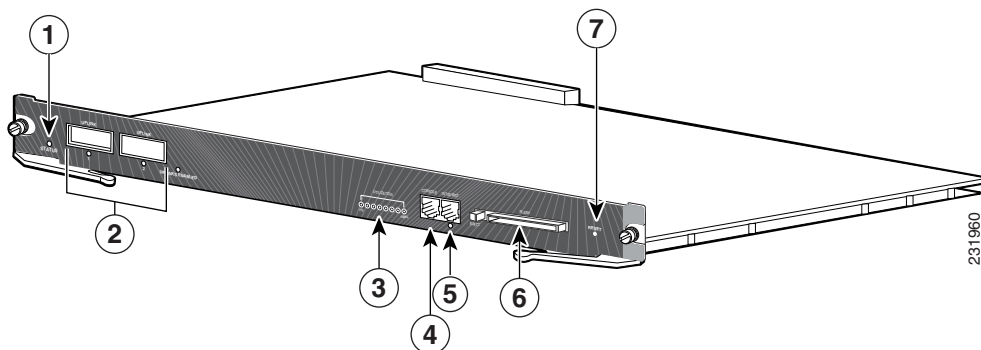
Feature	Description
Data path and control	Available on all network interfaces
Management functions	Interface monitoring Environmental status SNMP and console/Telnet interface
MAC addresses supported	32,768 per system (Cisco IOS only)
VLANs	Up to 4,096 VLANs with IEEE 802.1Q VLAN tagging on all ports and VLAN Trunking Protocol (VTP)
Port aggregation	PAgP <sup>1</sup> for 100-Mbps and 1000-Mbps EtherChannel
SNMP	Full implementation, including entity-MIB, all relevant standard MIBs, and all relevant Cisco MIBs
RMON	The first four groups (Ethernet statistics, Alarms, Events, and History) are on a per-port basis without an optional RMON processing module
SPAN <sup>2</sup>	Supported, which allows you to redirect traffic from any port or VLAN to a SPAN destination port
Performance management	Information provided
Hot-swappable	Supported. On non-redundant systems, packets are not forwarded while the supervisor engine is removed, and a system reboot occurs when a supervisor engine is reinserted.
Gigabit Ethernet (using a GBIC or SFP)	Includes two (four on WS-X4516-10GE and WS-X4013+10GE) Gigabit Ethernet (1000BASE-X) interfaces for backbone interconnection of high-performance switches and routers
10-Gigabit Ethernet (WS-X4516-10GE, WS-X4013+10GE and WS-X45-Sup6-E)	Includes two 10 Gigabit Ethernet interfaces for backbone interconnection of high-performance switches and routers
Forwarding	Layer 2, 3, and 4 forwarding (Cisco IOS only)

**Table 1-5 Supervisor Engine Features (continued)**

Feature	Description
Supervisor Engine II-Plus	64 Gbps, 48 Mpps (with Catalyst 4506-E and 4507R-E, or 28-Gbps, 21 Mpps with Catalyst 4503-E) full-duplex Gigabit Ethernet switching engine
Supervisor Engine II-Plus TS	64 Gbps, 48 Mpps (with Catalyst 4503-E only) full-duplex Gigabit Ethernet switching engine
Supervisor Engine II-Plus 10GE	108 Gbps, 81 Mpps full-duplex Gigabit Ethernet switching engine
Supervisor Engine IV	64 Gbps, 48 Mpps (with Catalyst 4506-E and 4507R-E, or 28-Gbps, 21 Mpps with Catalyst 4503-E) full-duplex Gigabit Ethernet switching engine
Supervisor Engine V	96-Gbps, 72 Mpps (with Catalyst 4510R-E, 68 Gbps, 51 Mpps with Catalyst 4507R-E, 64 Gbps, 48 Mpps with Catalyst 4506-E, 28 Gbps, 21 Mpps with Catalyst 4503-E) full-duplex Gigabit Ethernet switching engine
Supervisor Engine V-10GE	136-Gbps, 101 Mpps (with Catalyst 4510R-E, 68 Gbps, 51 Mpps with Catalyst 4507R-E, 64 Gbps, 48 Mpps with Catalyst 4506-E, 28 Gbps, 21 Mpps with Catalyst 4503-E) full-duplex Gigabit Ethernet switching engine
Supervisor Engine 6-E	320-Gbps, 250 Mpps (with Catalyst 4510R-E, 280 Gbps, 210 Mpps with Catalyst 4507R-E, 280 Gbps, 210 Mpps with Catalyst 4506-E, 136 Gbps, 102 Mpps with Catalyst 4503-E) full-duplex Gigabit Ethernet switching engine

1. PAgP = Port Aggregation Protocol
2. SPAN = switched port analyzer

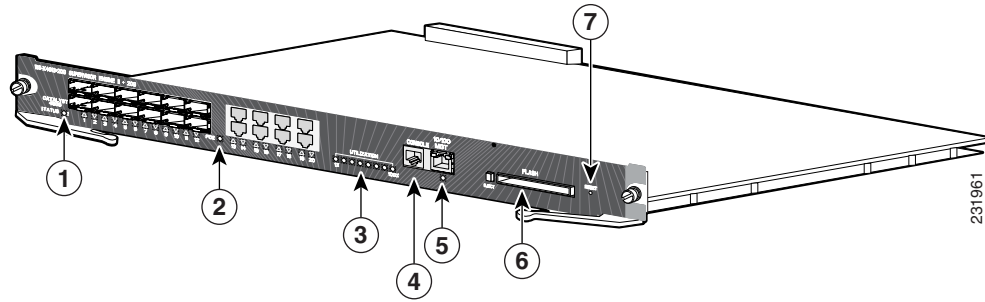
To install the supervisor engine, refer to the procedure in the *Catalyst 4500 Series Module Installation Guide*. The various supervisor engine models are shown in Figure 1-5 to Figure 1-10.

**Figure 1-5 Supervisor Engine II-Plus (WS-X4013+)**

<b>1</b>	Status LED	<b>5</b>	Management Port
----------	------------	----------	-----------------

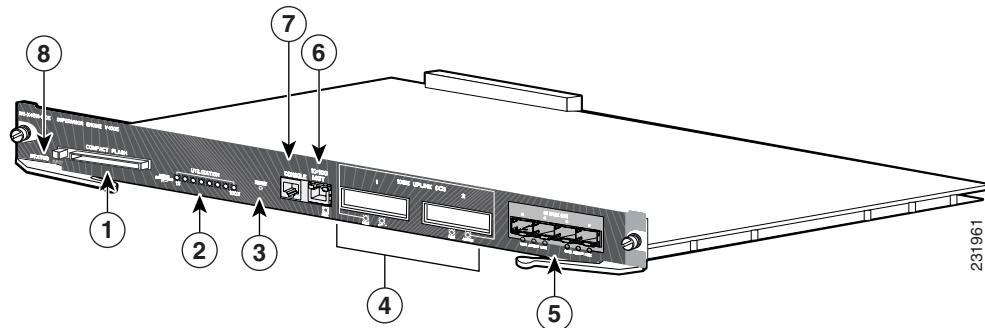
2	GBIC uplink ports	6	Compact flash port
3	Switch load indicators	7	Reset button
4	Console port		

Figure 1-6 Catalyst 4500 Series Supervisor Engine II-Plus TS (WS-X4013+TS)



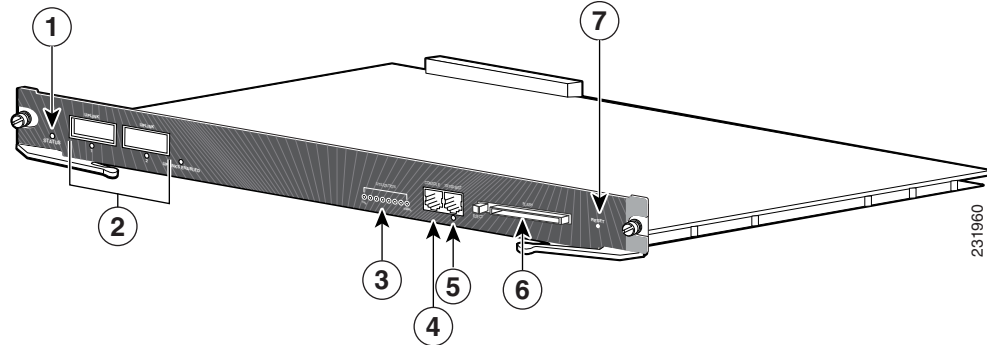
1	Status LED	5	Management port
2	PoE status LED	6	Compact Flash port
3	Switch load indicators	7	Reset button
4	Console port		

Figure 1-7 Supervisor Engine II-Plus 10GE (WS-X4013+10GE)



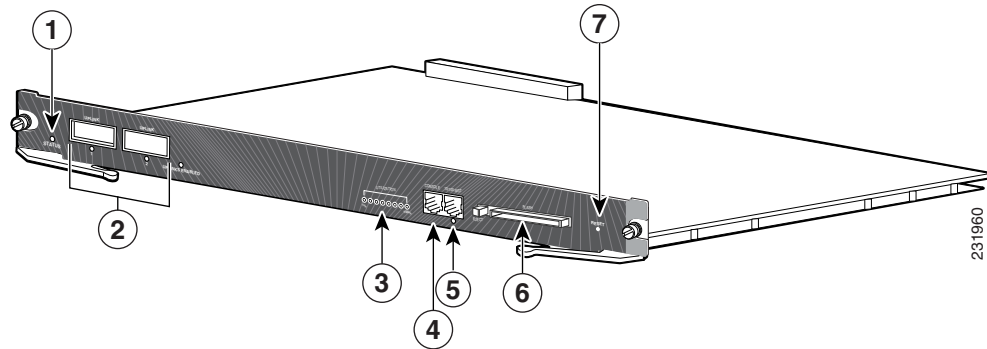
1	Compact flash port	5	Gigabit SFP ports
2	Switch load indicator	6	Management port
3	RESET button	7	CONSOLE port
4	10GE uplink ports	8	STATUS LED

**Figure 1-8 Supervisor Engine IV (WS-X4515)**



1	Status LED	5	Management port
2	GBIC uplink ports	6	Compact flash port
3	switch load indicators	7	Reset button
4	Console port		

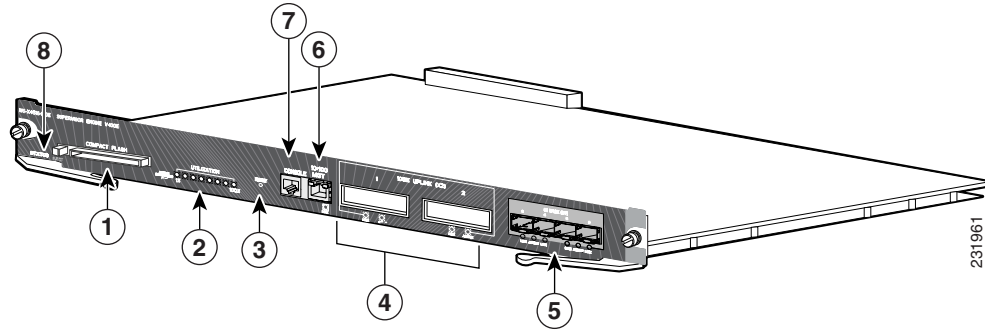
**Figure 1-9 Supervisor Engine V (WS-X4516)**



1	Status LED	5	Management port
2	GBIC uplink ports	6	Compact Flash port
3	Switch load indicators	7	Reset button
4	Console port		

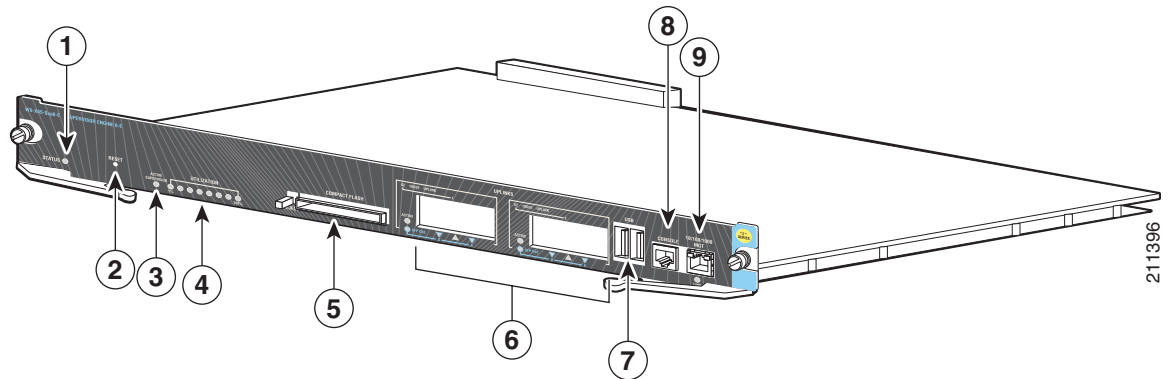


**Figure 1-10 Supervisor Engine V-10GE (WS-X4516-10GE)**



<b>1</b>	Compact flash port	<b>5</b>	Gigabit SFP ports
<b>2</b>	Switch load indicator	<b>6</b>	Management port
<b>3</b>	RESET button	<b>7</b>	CONSOLE port
<b>4</b>	10GE uplink ports	<b>8</b>	STATUS LED

**Figure 1-11 Supervisor Engine 6-E (WS-X45-Sup6-E)**



<b>1</b>	Status LED	<b>6</b>	Uplink ports
<b>2</b>	Reset button	<b>7</b>	USB port
<b>3</b>	Active supervisor LED	<b>8</b>	Console port
<b>4</b>	Utilization LEDs	<b>9</b>	Management port
<b>5</b>	Compact flash port		

For information about the connectors, LEDs, and switches located on the front panel of the supervisor engine, see these sections:

- LEDs, page 1-22
- Gigabit Ethernet Uplink Ports, page 1-22
- 10-Gigabit Ethernet Uplink Ports, page 1-23
- 10/100BASE-T Management Port, page 1-23
- CONSOLE Port, page 1-23

- RESET Button, page 1-24
- Compact Flash Slot, page 1-24

## LEDs

Table 1-6 describes the supervisor engine LEDs.

**Table 1-6 Supervisor Engine LEDs**

LED	Color/State	Description
STATUS	Green	All diagnostic tests passed.
	Red	A test failed.
	Orange	System boot or diagnostic test is in progress, or two power supplies are installed but only one is turned on.
	Off	Module is disabled.
UTILIZATION	Green 1–100%	If the switch is operational, this display indicates the current traffic load over the backplane (as an approximate percentage).
LINK	Green	The link is operational.
	Orange	The link is disabled by user.
	Flashing orange	The power-on self-test indicates a faulty port.
	Off	No signal is detected or there is a link configuration failure.
ACTIVE (uplink port)	Green	The port is active.
	Off	The port is not active.
ACTIVE		The LED to the right of the uplink ports is only used in switches with two supervisors. The LED lights on the active supervisor.

## Gigabit Ethernet Uplink Ports

The Gigabit Ethernet uplink ports operate in full-duplex mode only. GBICs have SC connectors to interface with multimode fiber (MMF) and single-mode fiber (SMF) cable. For more information about GBICs, refer to the *Catalyst 4500 Series Module Installation Guide*. Frequently updated compatibility information for GBICs, X2s, and SFPs are in documents at:

[http://www.cisco.com/en/US/products/hw/modules/ps5455/products\\_device\\_support\\_tables\\_list.html](http://www.cisco.com/en/US/products/hw/modules/ps5455/products_device_support_tables_list.html)

When two Supervisor Engine Vs are present in a Catalyst 4507R-E and Catalyst 4510R-E, all four uplinks are active on both Primary (active) and Secondary (standby) supervisor engines by default, or two uplinks are active in a non-redundant configuration. This limits access to slot 10 on the Catalyst 4510R to ports 3 and 4 only. You can only use the 2-port Gigabit Ethernet switching module (WS-X4302-GB) in slot 10 (flex-slot) when a Supervisor Engine V is used.

## 10-Gigabit Ethernet Uplink Ports

The 10-Gigabit Ethernet uplink ports operate in full-duplex mode only, and are only on the WS-X4516-10GE, WS-X4013+10GE, and WS-45-Sup6-E. These ports use the hot-swappable 10GBASE X2 optical transceivers. The X2s have SC connectors to interface with multimode fiber (MMF) and single-mode fiber (SMF) cable.

On a Catalyst 4510R-E with a Supervisor Engine V-10GE, the user can use either four Gigabit Ethernet uplinks using SFPs or two 10-Gigabit Ethernet uplinks using X2s. The user also has the option of using the Gigabit Ethernet and 10-Gigabit Ethernet uplinks simultaneously. With this option, the tenth slot can only support the WS-X4302-GB switching module. On a Catalyst 4507R-E, the user can use the Gigabit Ethernet uplinks and 10-Gigabit Ethernet uplinks simultaneously.

When two Supervisor Engine V-10GEs are present in a Catalyst 4510R-E or Catalyst 4507R-E switch, or two Supervisor Engine II-Plus 10GEs are present in a Catalyst 4507R-E, one X2 uplink is active on both the primary (active) and secondary (standby) supervisor engines by default, or two uplinks are active in a non-redundant configuration.

On a Catalyst 4510R-E with a Supervisor Engine 6-E, 10-Gigabit Ethernet uplinks using X2s are the only available uplinks. Slots 8-10 are intended for Catalyst 4500 classic switching modules only and all other slots may use classic or E-series switching modules.

When two Supervisor Engine 6-Es are present in a Catalyst 4510R-E or Catalyst 4507R-E switch, or two Supervisor Engine II-Plus 10GEs are present in a Catalyst 4507R-E, one X2 uplink is active on both the primary (active) and secondary (standby) supervisor engines by default, or two uplinks are active in a non-redundant configuration.

## SFP Ports

Gigabit Ethernet SFP ports operate in full-duplex mode only and are present on the WS-X4013+TS, WS-X4516-10GE, and WS-X4013+10GE supervisors, as well as some switching modules. WS-X45-Sup6-E supervisors can use Cisco TwinGig converters to support two SFPs per X2 uplink port, for a maximum of 4 SFP ports per supervisor. SFP connectors vary with interface type and may use multimode fiber (MMF), single-mode fiber (SMF) cable, or copper Ethernet cables. SFPs use LC type fiber connectors and RJ-45 copper connectors.

## 10/100BASE-T Management Port

The 10/100BASE-T Management port supports emergency image recovery. The 10/100BASE-T port supports image downloads from the ROMMON. You can use this feature when the onboard Flash memory does not contain any IOS images, usually after all images were accidentally deleted from onboard Flash.

## CONSOLE Port

The CONSOLE port has an EIA/TIA-232 RJ-45 connector. The CONSOLE port allows you to perform the following functions:

- Configure the switch from the CLI
- Monitor network statistics and errors
- Configure SNMP agent parameters

**Note**

---

EIA/TIA-232 was known as recommended standard RS-232 before its acceptance as a standard by the Electronic Industries Alliance (EIA) and Telecommunications Industry Association (TIA).

---

## RESET Button

The RESET button is used to restart the switch.

**Note**

---

Use a paper clip or other small, pointed object to press the Reset button.

---

## Compact Flash Slot

The Compact Flash slot accepts a Type 1 Compact Flash disk. You can use it for file transfer tasks such as loading a new software image. The Compact Flash card is optional. For more information, refer to *Using the Compact Flash on the Catalyst 4500 Supervisor Engines* at the following URL:

[http://www.cisco.com/en/US/docs/switches/lan/catalyst4500/hardware/configuration/notes/OL\\_2788.html](http://www.cisco.com/en/US/docs/switches/lan/catalyst4500/hardware/configuration/notes/OL_2788.html)

## Fan Assembly

**Note**

---

For complete environmental specifications, including airflow requirements, see Appendix A, “Specifications.”

---

The system fan assembly provides cooling air for the internal chassis components. The fan assembly is a tray of fans that you can insert and remove from the chassis while the system is on line. The Catalyst 4503-E fan assembly has two fans and the Catalyst 4506-E fan assembly has four fans, the Catalyst 4507R-E fan assembly has eight fans, and the Catalyst 4510R-E fan assembly has ten fans. The fans draw in fresh air from one side and exhaust air on the other side. Catalyst 4506-E airflow is shown in Figure 1-12, the others in the series are the same direction.

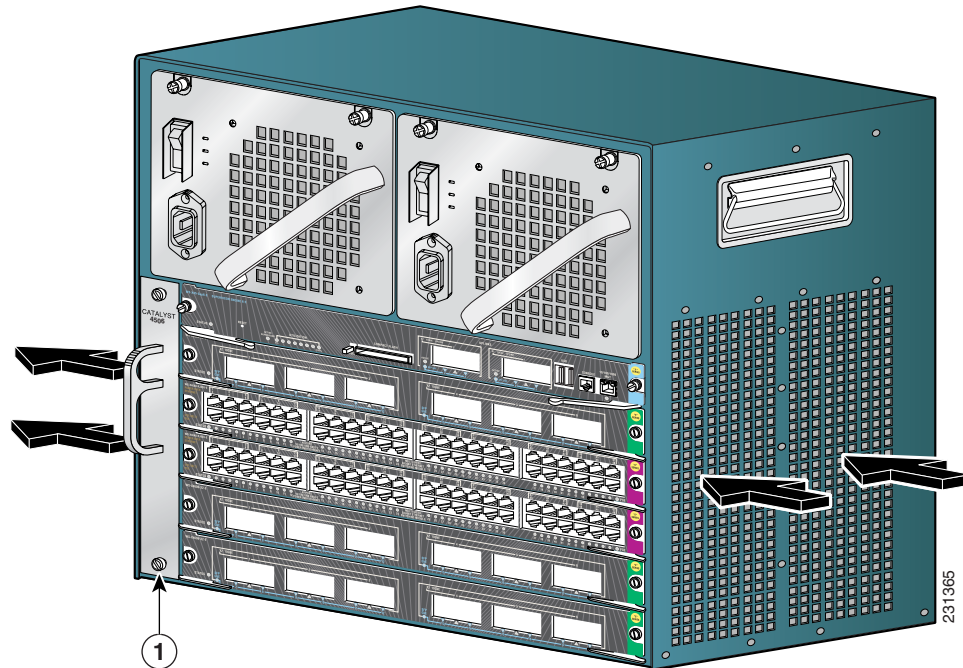
**Caution**

---

You must install module filler plates on unused switching module slots to ensure proper airflow.

---

Figure 1-12 Catalyst 4506-E Airflow



1	Fan assembly
---	--------------

## Power Supplies



### Note

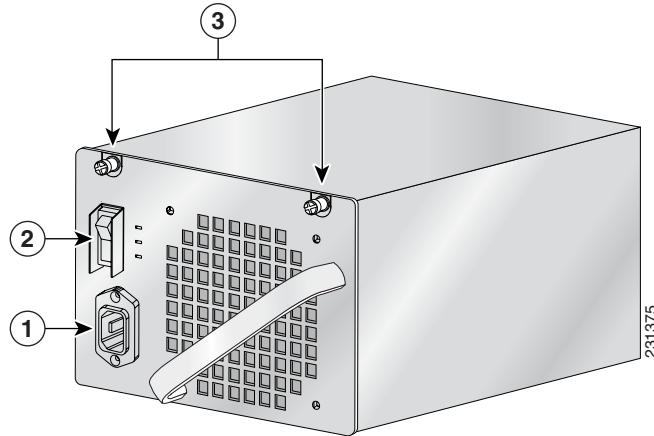
For detailed specifications on all Catalyst 4500 power supplies, refer to the “Catalyst 4507R-E Switch Specifications” section on page A-3.

A Catalyst 4500 E-series switch can use a 1000 W, 1300 W, 1400 W, 2800 W (see Figure 1-13), or 4200 W (with two inputs, see Figure 1-14) AC-input power supply, a 1400 W DC-input power supply with integrated PEM (see Figure 1-15), or a 1400 W DC multiple-input power supply (see Figure 1-16). The power supplies are hot-swappable. If you have power supplies of different types installed in the two bays, only one will be active and some power features will not be available. The power supply in the left bay is PS1, the one in the right bay is PS2.

The AC-input power supply has a power cord that connects each power supply to the site power source. The DC-input power supply is equipped with an input terminal block that is directly connected to the site power wiring.

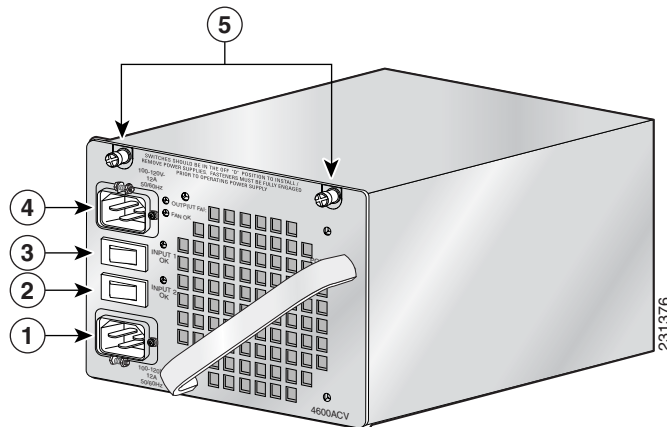
Each power supply has an ON/OFF switch that supplies power to the switch. For information on removing and replacing power supplies, see the “Removing and Replacing the Power Supply” section on page 4-2.

**Figure 1-13 AC-Input Power Supply (All Except 4200 W)**



1	AC receptacle	3	Captive screws
2	Power switch		

**Figure 1-14 4200 W Dual Input AC Power Supply**

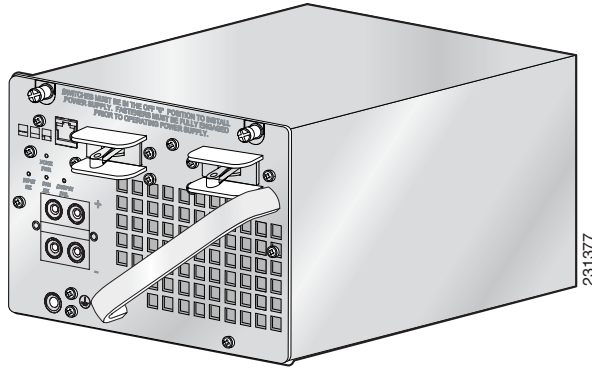
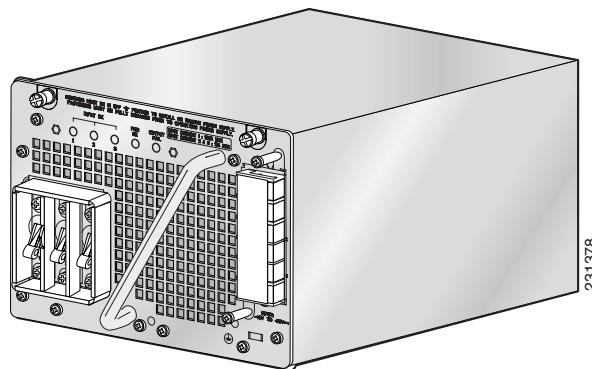


1	AC input 2 receptacle	4	AC input 1 receptacle
2	AC input 2 on switch	5	Captive screws
3	AC input 1 on switch		



**Note**

The 4200 W AC power supply should not be used in mixed-voltage configurations. All the inputs in a chassis must be the same voltage (110 or 220 V).

**Figure 1-15 1400 W DC-Input Power Supply****Figure 1-16 1400 W DC Triple-Input Power Supply****Note**

The 1400 W DC triple-input power supply is not compatible with other power supplies used on these products, and can only be used with similar supplies. In redundant mode, the two power supplies must have identical inputs.

The 1400 W DC input power supply (either single or triple-input) may be used with the Catalyst 4500 Series AC Power Shelf. Documentation for the Catalyst 4500 Series AC Power Shelf is at [http://www.cisco.com/en/US/docs/switches/lan/catalyst4500/hardware/configuration/notes/78\\_15068.html](http://www.cisco.com/en/US/docs/switches/lan/catalyst4500/hardware/configuration/notes/78_15068.html)

Catalyst 4500 E-series switches support one power supply and an optional redundant power supply. Each AC power supply has an individual power cord and status LEDs. Systems with redundant power supplies will share the load, with each unit providing approximately one-half of the total load. For information about configuring your switch for redundant and combined modes, refer to the software configuration guide for your switch.

The Catalyst 4510R-E requires at least 1400 W of input power. (The 1000 W AC and 1300 W AC power supplies will fit and function in a Catalyst 4510R-E; however, power management may be required in high density configurations.) Cisco recommends the use of the 1400 W DC, 1400 W AC, and 2800 W AC power supplies for the Catalyst 4510R-E.

When power is removed from one power supply on a Catalyst 4500 E-series switch that has two power supplies, the redundant power feature causes the second power supply to produce full power.

To replace a power supply, see the “Removing and Replacing the Power Supply” section on page 4-2.

## Power Supply LEDs

Table 1-7 describes the power supply LEDs.

**Table 1-7** Power Supply LEDs

LED	Color/State	Description
INPUT OK	Green	Indicates whether the input voltage is within the required range: Input voltage is within the required range.
	Flashing	Input voltage is present, but is below required range.
	Off	Input voltage is below the required range or the power supply is off.
OUTPUT FAIL	Red	Output voltage is not within the specified range.
	Off	Output voltage is within the specified range.
FAN OK	Green	Indicates the status of the power supply fans: The fans are operational.
	Off	The fans are not operational.
In-line PWR (for 1400 W DC single input power supplies)	Green	–48 V passthru output voltage is enabled and is greater than –39 V and less than –60 V.
	Off	Indicates any of the following: <ul style="list-style-type: none"> <li>• Passthru breakers are not enabled.</li> <li>• DC input is less than –40.5 V.</li> <li>• One or more –48 V outputs is less than –39 V.</li> </ul>
	Amber	Passthru breakers are enabled and input voltage exceeds –60 V.

## Power Supply Fan

Each power supply has a built-in fan. Air enters the front of the power supply (power-input end) and exits through the back. An air dam keeps the airflow separate from the rest of the chassis, which is cooled by the system fan assembly.

## Load-Sharing Feature

When you install and turn on a second power supply on a Catalyst 4500 E-series switch, it provides approximately one-half of the required power to the system. If one power supply fails, the other power supply immediately assumes full power to maintain uninterrupted system operation.



### Note

Load sharing works only when both power supplies in the chassis are the same type.



When you install a redundant power supply, load sharing and fault tolerance are enabled automatically; no additional software configuration is required.

## Environmental Monitoring Feature

With the environmental monitoring and reporting feature, you can keep your system running by resolving adverse environmental conditions before loss of operation.

The power supply monitors its own internal temperature and voltages. In the event of excessive internal temperature, the power supply shuts down to prevent damage. When the power supply returns to a safe operating temperature, it restarts. If the power supply output voltage is not within the specified range, the LED labeled OUTPUT FAIL will light. An instance of substantial output overvoltage can shut down the power supply.

An instance of substantial input over-voltage (greater than –75 V DC continuous) can damage the power supply input circuitry and can cause it to shut down permanently.

For a 1400 W DC power supply, the main power switch has an input range of –40.5 to –72 V DC, while the –48 V PoE operates over a range of –40.5 to –56 V DC. The PoE either fails to start or shuts down if exposed to greater than –56 V DC input. PoE recovers after you recycle input power within the proper voltage range. If the PoE shuts down due to input over-voltage (greater than –56 V DC), the main converter section does not shut down.

The supervisor engine monitors the status of each power supply and provides a status report through the switch software. For more details on how the supervisor engine monitors the power supplies, refer to the “Environmental Monitoring and Power Management” chapter of the *Catalyst 4500 Series Switch Cisco IOS Software Configuration Guide*.

## 1400 W DC Triple-input Power Supply Operational Modes

The 1400 W DC Triple Input SP Power Supply (data only) allows added redundancy by providing terminals for two DC inputs rated at 15 A and one rated at 12.5 A per power supply.

This power supply has five operational modes depending on the inputs receiving power. When all three inputs are active, at input voltages greater than –44.0 V DC, the power supply delivers 1400 W maximum total output. Table 1-8 provides output information for these modes, given a single supply.

**Table 1-8 Input Modes**

Input Mode	Input Number	Input Configuration	Maximum Total Output Power
1	1	1 x 12.5 A	386 W @ –40.5 V DC 412 W @ –44.0 V DC
2	2 OR 3	1 x 15 A	466 W @ –40.5 V DC 495 W @ –44.0 V DC
3	1, 2 OR 3	1 x 12.5 A and 1 x 15 A	845 W @ –40.5 V DC 908 W @ –44.0 V DC
4	2, 3	2 x 15A	914 W @ –40.5 V DC 990 W @ –44.0 V DC
5	1, 2, 3	1 x 12.5A and 2 x 15 A	1294 W @ –40.5 V DC 1400 W @ –44.0 V DC

The maximum total input current is 42.5A and the maximum ambient temperature is 55 C. To determine total maximum input power to a supply, add up the active individual module input power ratings. Table 1-9 provides output information for these modes, given two supplies working in combined mode. Table 1-10 provides output information for these modes, given two supplies working in redundant mode.

**Table 1-9 Combined Mode Power Supply Configuration  
(2450 W Max Output Power)**

Input Number	Maximum Input Current	Maximum Input Power @ -44 V DC
1	12.5 A @ -44 V DC	550 W
2	15 A @ -44 V DC	660 W
3	15 A @ -44 V DC	660 W

**Table 1-10 Dual Redundant Mode Power Supply Configuration  
(1400 W Max Output Power)**

Input Number	Approximate Input Current	Approximate Input Power @ -40.5 V DC	Approximate Input Power @ -44 V DC
1	6.25 A @ -40.5 / -44 V DC	253 W	275 W
2	7.5 A @ -40.5 / -44 V DC	304 W	330 W
3	7.5 A @ -40.5 / -44 V DC	304 W	330 W



**Note**

In a redundant configuration with all inputs supplied, there must be a 100 W minimum system load or the OUTPUT FAIL LED shows a false failure.

The 1400 W DC Triple Input SP Power Supply requires a minimum draw from the system that it is installed in. Table 1-11 shows the minimum draw for the possible modes.

**Table 1-11 Minimum Load Table**

	PSU1			PSU2			12V Minimum Load	3.3V Minimum Load
	Input 1	Input 2	Input 3	Input 1	Input 2	Input 3		
<b>Single Operation</b>								
Mode 1	ON	OFF	OFF	–	–	–	1.33A	0.6A
Mode 2	OFF	ON	OFF	–	–	–	1.33A	0.6A
	OFF	OFF	ON	–	–	–	1.33A	0.6A
Mode 3	ON	ON	OFF	–	–	–	2.66A	0.6A
	ON	OFF	ON	–	–	–	2.66A	0.6A
Mode 4	OFF	ON	ON	–	–	–	2.66A	0.6A

Table 1-11 Minimum Load Table (continued)

	PSU1			PSU2			12V Minimum Load	3.3V Minimum Load
	Input 1	Input 2	Input 3	Input 1	Input 2	Input 3		
Mode 5	ON	ON	ON	–	–	–	4A	0.6A
<b>Dual Redundant Operation</b>								
Mode 1	ON	OFF	OFF	ON	OFF	OFF	2.66A	1.2A
Mode 2	OFF	ON	OFF	OFF	ON	OFF	2.66A	1.2A
	OFF	OFF	ON	OFF	OFF	ON	2.66A	1.2A
Mode 3	ON	ON	OFF	ON	ON	OFF	5.32A	1.2A
	ON	OFF	ON	ON	OFF	ON	5.32A	1.2A
Mode 4	OFF	ON	ON	OFF	ON	ON	5.32A	1.2A
Mode 5	ON	ON	ON	ON	ON	ON	8A	1.2A

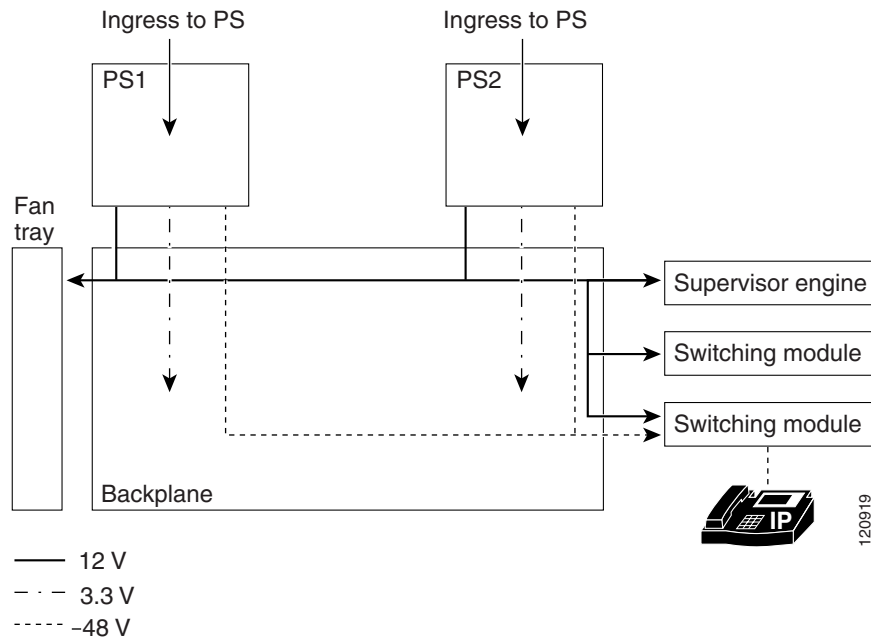
## System Architecture

This section describes the interaction between the various system components of Catalyst 4500 E-series switches. Only the Catalyst 4503-E switch is shown in the examples.

## Power Flow

Figure 1-17 shows power ingress and flow through the system.

**Figure 1-17 Power Flow**



Power enters the switch through the power supplies. Several types of power supplies are available, depending on the power needs for your system and the power type available on your site. All power supplies provide a 3.3 V circuit (shown as a dash-dot line) to the components on the backplane and a 12 V circuit (shown as a solid line) that is carried over the backplane to the fans, supervisor engine, and switching modules. Power supplies that support PoE (1300 W AC, 2800 W AC, 4200 W AC or 1400 W DC) also provide a -48 V circuit (shown as a dashed line) to PoE-enabled switching modules, which is then available to the powered device connected to the switching module.



### Note

The Supervisor Engine II-Plus TS has internal DC-to-DC converters that use the 12 V circuit to provide PoE to powered devices connected to the Supervisor engine only. If your system has a Supervisor Engine II-Plus TS in slot 1, you still need a PoE-enabled power supply to provide PoE to the other slots.

All Catalyst 4500 E-series switches support dual power supplies, configurable for combined mode or redundant mode. In combined mode, the switch has available the combined rated wattage of both power supplies, less some expected efficiency loss. In redundant mode, one power supply provides power to the system and the other supply is on standby should there be a failure in either the power supply or the input voltage source it is connected to.

## Power over Ethernet

The Cisco Catalyst 4500 E-series switches support the 802.3af standard for PoE on 10/100 or 10/100/1000 ports, enabling customers to support telephones, wireless base stations, video cameras, and other appliances. PoE makes it possible to place devices in unique locations without having to provide

new outlets and costly electrical circuits. PoE also enables businesses to isolate critical devices on a single power system so that the entire system can be supported by uninterruptable power supply (UPS) backup.

All new Cisco Catalyst PoE switching modules can support 15.4 W of power per port simultaneously. Not only do the modules support the IEEE standard, including the optional power classifications, but the Cisco pre-standard power implementation is also supported to help ensure backward compatibility with existing Cisco powered devices. The modules are compatible with any chassis and supervisor engine. Most importantly, the Catalyst 4500 E-series switch has the power supplies and accessories to support 15.4 W per port on every port simultaneously in any fully loaded chassis. (This requires an external power shelf or a 4200 W dual-input power supply.)

## PoE Over-subscription

With the advent of powered devices requiring as much as 15.4 W and the different combinations of power supplies and chassis port densities, it becomes quite possible to over-subscribe the PoE capacity of the power supplies. This temporary over-subscription typically occurs when a power supply configured in combined mode fails or when the user has not kept track of the powered devices and plugs in one too many. The best practice is to design a PoE system in which all devices receive the power needed at all times. When a power supply is over-subscribed—more power is being drawn from it than it can supply—the power supply shuts down. There are several ways to predictably manage a temporary PoE over-subscription:

1. Configure unused ports to never receive PoE. This prevents a user from inadvertently plugging a powered device into a port and causing problems for other powered devices.
2. Configure ports to be in static mode. This is for ports that have highest priority, such as phones for executives or wireless access points. If ports need to be disabled because of a power shortage, auto ports are disabled before static ports.
3. Configure the maximum wattage on ports to be less than the default, based on the maximum power consumption of the powered device. This disallows devices demanding unexpected amounts of power and also stretches the finite resources of the power supplies. For example, the default port wattage is 15.4 W. By configuring a maximum of 7 W, twice as many PoE powered devices can be supported with the same power supply.

## PoE Switching Modules

The Cisco Catalyst 4500 E-series offers switching modules, power supplies, and accessories required to deploy and operate a standards-based PoE internetwork. PoE provides –48 V DC power over standard Category 5 unshielded twisted-pair (UTP) cable up to 100 meters when an IEEE 802.3af-compliant or Cisco pre-standard powered device is attached to the PoE switching module port. Instead of requiring wall power, attached devices such as IP phones, wireless base stations, video cameras, and other IEEE-compliant appliances can use power provided by the PoE switching modules. This capability gives network administrators centralized control over power and eliminates the need to install outlets in ceilings and other out-of-the-way places where a powered device may be installed.

Although references to “PoE,” “inline-power,” and “voice” power supplies and switching modules are synonymous, there are only two versions: Cisco prestandard and IEEE 802.3af compliant. Every Cisco Catalyst 4500 E-series chassis and PoE power supply supports the IEEE 802.3af standard and the Cisco prestandard power implementation ensuring backward compatibility with existing Cisco powered devices. All IEEE 802.3af-compliant switching modules can distinguish an IEEE or Cisco prestandard powered device from an unpowered network interface card (NIC), ensuring that power is applied only when an appropriate device is connected.

All PoE switching modules can distinguish an IEEE or Cisco prestandard powered device from an unpowered network interface card (NIC) to ensure power is applied only when an appropriate device is connected. With a Cisco PoE network, administrators can depend on a robust network that is safe to deploy and simple to maintain.

### Deploying PoE on the Cisco Catalyst 4500 E-series

When the switch is properly configured, implementing PoE is easy when it is used with a Cisco powered device that supports Cisco Discovery Protocol. All PoE switching modules automatically detect an attached powered device the moment it is installed. Also, the switch returns unused port power to the system power budget for use by other devices because it supports the IEEE802.3af optional power classifications.

The Cisco Catalyst 4500 E-series offers internal power supplies and external power devices for multiple deployment scenarios. These scenarios include small and large deployments in AC or DC environments for data-only configurations, and scalability of up to 15.4 W per port for PoE configurations.

The switches share a common power supply form factor. Each Cisco Catalyst 4500 E-series chassis is designed for 1 + 1 power protection while meeting the needs of PoE demands. In addition to power resiliency, the Cisco Catalyst 4500 E-series includes 1 + 1 supervisor-engine redundancy (Cisco Catalyst 4507R-E and Catalyst 4510R-E only) and software-based fault tolerance. Integrated resiliency in both hardware and software minimizes network downtime, helping ensure workforce productivity, portability, and customer success.

All available Cisco Catalyst 4500 E-series compatible power supplies can be used for data-only deployments, which typically require just a few hundred watts. For deployments that dictate support for PoE power, Cisco offers several options.

The Cisco Catalyst 4500 E-series offers several internal supplies: 1000 W AC (data only), 1400 W AC (data only), 1300 W (data and PoE), 1400 W DC (data and PoE), 2800 W (data and PoE), and 4200 W AC (data and PoE). When more than 4200 W of redundant data and PoE are required for a Cisco Catalyst 4500 E-series chassis in an AC-powered environment, Cisco offers an external AC power shelf that houses two 2500 W AC power supplies. When two power shelves are combined, they can produce 7500 W—the remaining 2500 W supply can be used for N + 1 protection.

The Cisco Catalyst 4500 E-series has two DC power options; one is optimized for data-only deployments in service provider central offices (part number PWR-C45-1400DC), and the other is used for high-power PoE deployments (part number PWR-C45-1400DC-P).

### Cisco Catalyst 4500 Series External AC Power Shelf and 1400 W DC Power Supply with Integrated Power Entry Module

The external AC power shelf must be used in conjunction with the 1400 W DC power supply. In addition to providing power for the chassis, fans, and non-PoE switching modules, the 1400 W DC power supply contains a power entry module (PEM). The PEM is used to pass additional power to the chassis backplane, power demanded by the PoE switching modules. The chassis power trace used for PoE is independent from the one used by the supervisor engine(s), fan tray, and backplane components. The 1400 W DC power supply can accept up to 7500 W DC for data and PoE applications. Up to 1400 W can be dedicated for data (supervisor engine, fan tray, etc.), while the remaining power is passed through via the PEM and is used for PoE.

When only one external AC power shelf is used (with two 2500 W AC power supplies), it provides the 1400 W DC power supply with 5000 W of DC power in total. When two AC power shelves are strapped together, the switch can provide up to 7500 W of DC power (3 + 1 redundant).

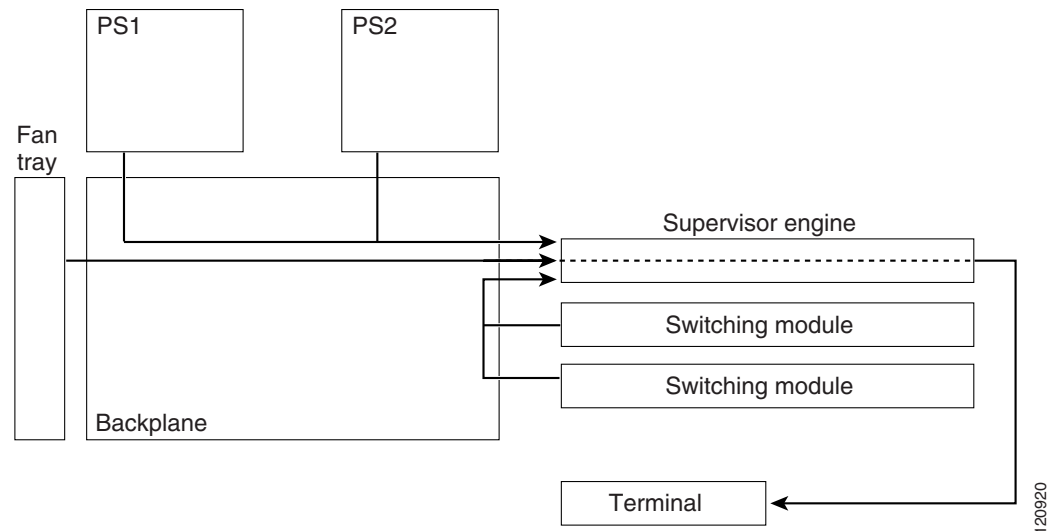
## Cisco Catalyst 4500 Series Service Provider DC Power Supply

The triple-input 1400 W DC power supply is optimized for service provider or central-office deployments. By providing multiple inputs, the service provider DC power supply enables central-office technicians to customize the output power to meet their application needs. Many central-office deployments require only a fraction of the 1400 W available in the service provider power supply. Low current inputs mean technicians can connect the supply to smaller fuses and breakers. The service provider power supply makes it possible to deploy a Cisco Catalyst 4503-E with a single 15 A circuit. Likewise, it is possible to deploy a fully populated Cisco Catalyst 4510R-E with two 20 A and one 15 A circuits rather than a single 60 A connection, which often requires rack rewiring.

## Management Flow

Figure 1-18 shows management and status information flow through the system.

**Figure 1-18 Management Flow**



Each system component has an EEPROM that identifies it to the supervisor engine over a serial connection on the backplane, which also passes along information like temperature, fan speed, power draw per slot and port, and port activity. LED status information is also sent to the supervisor engine, which makes it available to an administrator through a terminal connection or management software.

All Catalyst 4500 E-series switches support:

- Cisco Group Management Protocol, for standards-based and Cisco technology-enhanced efficient multimedia networking.
- Simple Network Management Protocol (SNMP).
- CiscoWorks, which can manage critical network characteristics such as availability, responsiveness, resilience, and security.
- Cisco NetFlow Services. The Cisco NetFlow Services Card for the Supervisor Engine IV and V support statistics capture in hardware for flow-based and VLAN-based statistics monitoring. This data can be exported, collected, and analyzed for virus detection and mitigation, network-traffic accounting, usage-based network billing, network planning, network monitoring, and data-mining capabilities. Cisco NetFlow Services is integral to the Supervisor Engine V-10GE.

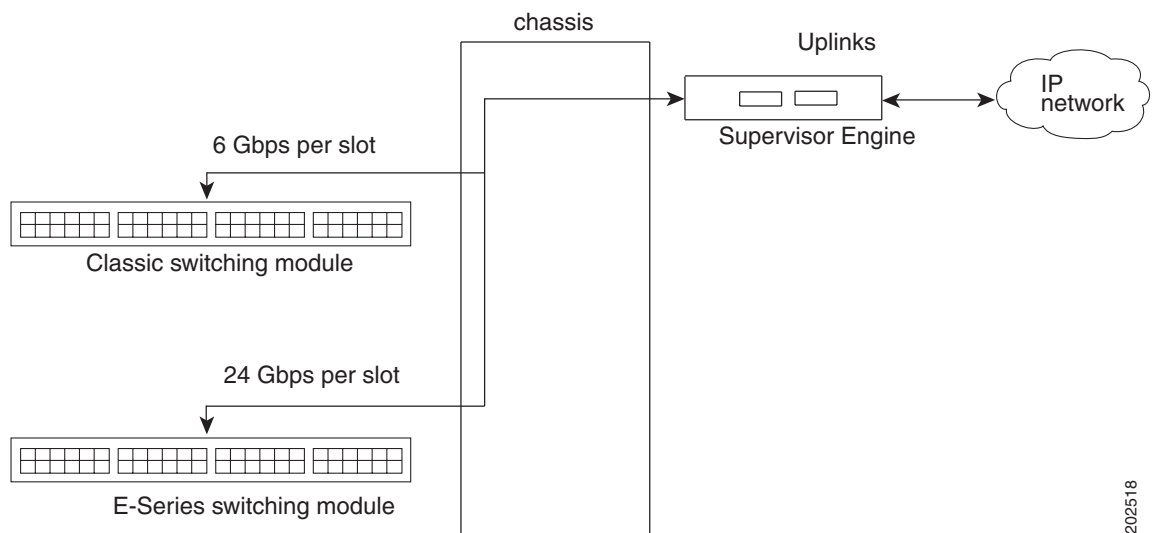
## Switching Traffic Flow

All Catalyst 4500 series switches use a shared memory switching fabric. All forwarding decisions, QoS, security policies and transmit queuing are implemented in the Supervisor Engine. Individual switching modules are transparent, and only contain simple stub ASICs and PHYs; they do not perform buffering or local switching. Classic switching modules and Classic IOS supervisor engines have a per slot switching capacity of 6 Gbps, while E-series switching modules and supervisor engines have a per slot switching capacity of 24 Gbps.

Frames flow into the switch through interfaces on the switching modules. Each switching module connects to a backplane that supports a connection of up to 24 Gbps up to the supervisor engine. When a frame reaches the supervisor engine, and a forwarding decision is made, the packet is sent out a port on the same switching module, a different switching module, or the supervisor engine uplinks.

Figure 1-19 shows a conceptual diagram of switching traffic flow through the system.

**Figure 1-19 Switching Traffic Flow**



202518

## Over-subscription

Classic Catalyst 4500 Series 48 port 10/100/1000 E-Series Switching modules are 8:1 oversubscribed and Catalyst 4500 E-Series 48 port 10/100/1000 Switching modules are 2:1 oversubscribed. On both types of switching modules, there are multiplexing ASIC's which group the front panel ports and multiplex them to the internal switch fabric. On a 48 port 10/100/1000 Classic Catalyst 4500 Series switching module, eight front panel ports are multiplexed into a single, nonblocking, full-duplex Gigabit Ethernet connection to the internal switch fabric of the Catalyst 4500 Classic Supervisors or the Supervisor 6-E. On the Catalyst 4500 E-series 48 port 10/100/1000 switching modules, six front panel ports are multiplexed into a 3 gigabit nonblocking, full-duplex Ethernet connection to the internal switch fabric on the Supervisor Engine 6-E.

If the data rate received for a port presents a potential overflow condition, flow control sends pause frames to the remote port to temporarily stop traffic and prevent frame loss. For both Classic and E-series switching modules each port operates independently so that flow control, or configuration of one port, does not block or degrade the performance of another port in that group.

The 6 port 2.5:1 oversubscribed 10GbE X2 based switching module operates in a similar way. The six front panel ports are multiplexed by groups of three into two ASICS, each having a 12 gigabit connection into the internal switch fabric.



In a Catalyst 4500 E-series chassis with the Supervisor 6-E, there is no performance degradation when both Classic and E-series line cards are mixed within the chassis. The Classic switching modules will continue to operate at 6 gigabits per slot and the E-series switching modules will operate at 24 gigabits per slot.

### Supervisor Redundancy

The Cisco Catalyst 4507R-E and Catalyst 4510R-E switches support 1+1 supervisor-engine redundancy for integrated resiliency. Redundant supervisor engines help minimize network downtime. With the support of stateful switchover (SSO), the secondary supervisor engine serves as a backup to immediately take over after a primary supervisor failure. During the switchover, Layer 2 links are maintained transparently without the need to renegotiate sessions. As a result, business-critical applications such as Voice-over-IP (VoIP) calls are not dropped. The Nonstop Forwarding (NSF) Aware feature in Cisco IOS software is also supported, providing the ability to interface with NSF-capable devices and to continue forwarding packets as routing information is updated upon a supervisor-engine switchover.





## CHAPTER 2

# Preparing for Installation

---

  
Warning

---

**This unit is intended for installation in restricted access areas. A restricted access area can be accessed only through the use of a special tool, lock and key, or other means of security.**  
Statement 1017

---

  
Warning

---

**Only trained and qualified personnel should be allowed to install, replace, or service this equipment.**  
Statement 1030

---

  
Warning

---

**This equipment must be grounded. Never defeat the ground conductor or operate the equipment in the absence of a suitably installed ground conductor. Contact the appropriate electrical inspection authority or an electrician if you are uncertain that suitable grounding is available.** Statement 1024

---

  
Warning

---

**Class 1 laser product.** Statement 1008

---

If you will be using your switch as a PoE source, the following warning applies:

  
Warning

---

**Voltages that present a shock hazard can exist on inline power circuits if interconnections are made by using uninsulated exposed metal contacts, conductors, or terminals. Avoid using such interconnection methods unless the exposed metal parts are in a restricted access location and users and service people who are authorized to access the location are made aware of the hazard. A restricted access area can be accessed only through the use of a special tool, lock and key, or other means of security.** Statement 1072

---

This chapter describes how to prepare your site for the installation of the switch. The information is presented in these sections:

- Electrostatic Discharge, page 2-2
- Site Power Requirements and Heat Dissipation, page 2-3
- Power Connection Guidelines for AC-Powered Systems, page 2-3
- Site-Planning Checklist, page 2-11

**Note**

See the Site-Planning Checklist at the end of this chapter to help ensure that you complete all site-planning activities before you install the switch.

## Electrostatic Discharge

Electrostatic discharge is common on Category 5E and Category 6 cabling systems.

Category 5E and Category 6 cables have higher capacitance than Category 5 cables. As a result, Category 5E and Category 6 cables can store higher voltages than Category 5 cables and are more prone to damaging networking equipment if a differential discharge event occurs.

Unshielded twisted-pair cables can store high voltages. When these charged cables are connected to networking equipment, energy is discharged into the networking equipment; this is known as electrostatic discharge (ESD). Networking equipment is commonly designed and tested to withstand common mode ESD events of up to 2000 V. The design for the common mode event is based on the expectation that the discharge is delivered to all pins of a port at once. Sometimes, voltage is discharged to some of the pins of the connector and not others, or to some pins on the connector before others. This is known as a differential discharge event, which can damage the networking equipment being connected.

You can take the following measures to prevent ESD cable damage:

- Ground the cable before connecting the networking equipment. You can create a grounding cable using an RJ-45 patch cable by doing the following:
  - Bare the wires on one end
  - Connect the wires to a suitable and safe earth ground
  - Connect the RJ-45 cable to a female RJ-45 connector
- Briefly connect all cables to the grounded cable before connecting to networking equipment.
- Leave cables from the networking equipment in the distribution closet connected to ports at user desktops. After you make connections on either side of the cable to networking equipment, the cable will not build up charge.

## Preventing Electrostatic Discharge Damage

Electrostatic discharge (ESD) damage, which can occur when electronic cards or components are improperly handled, results in complete or intermittent failures. Port adapters and processor modules consist of printed circuit boards that are fixed in metal carriers. Electromagnetic interference (EMI) shielding and connectors are integral components of the carrier. Although the metal carrier helps to protect the board from ESD, use a preventive antistatic strap during handling.

Following are guidelines for preventing ESD damage:

- Always use an ESD wrist or ankle strap and ensure that it makes good skin contact.
- Connect the equipment end of the strap to an unfinished chassis surface.
- When installing a component, use any available ejector levers or captive installation screws to properly seat the bus connectors in the backplane or midplane. These devices prevent accidental removal, provide proper grounding for the system, and help to ensure that bus connectors are properly seated.

- When removing a component, use any available ejector levers or captive installation screws to release the bus connectors from the backplane or midplane.
- Handle carriers by available handles or edges only; avoid touching the printed circuit boards or connectors.
- Place a removed component board-side-up on an antistatic surface or in a static shielding container. If you plan to return the component to the factory, immediately place it in a static shielding container.
- Avoid contact between the printed circuit boards and clothing. The wrist strap only protects components from ESD voltages on the body; ESD voltages on clothing can still cause damage.
- Never attempt to remove the printed circuit board from the metal carrier.

**Caution**

For safety, periodically check the resistance value of the antistatic strap. The measurement should be between 1 and 10 megohm (Mohm).

## Site Power Requirements and Heat Dissipation

This section provides module power requirements and heat dissipation specifications for the Catalyst 4500 E-series switches. You should verify site power before you install the switch.

For more information about power management and planning, refer to the “Environmental Monitoring and Power Management” chapter in the *Catalyst 4500 Series Switch Cisco IOS Software Configuration Guide* version appropriate for your software.

Knowing the power requirements is useful for planning the power distribution system needed to support the switches. You should consider the heat dissipation specifications when estimating the air-conditioning requirements for an installation. For all Catalyst 4500 series switches, supervisor engines, and switching modules in AC or DC environments see the *Catalyst 4500 Series Module Installation Guide* at:

<http://www.cisco.com/en/US/docs/switches/lan/catalyst4500/hardware/module/guide/0aspecs.html#wp1007594>

Catalyst 4500 E-series supervisor engines and switching modules are discussed elsewhere in this book.

## Power Connection Guidelines for AC-Powered Systems

This section provides guidelines for connecting the Catalyst 4500 E-series switch AC power supplies to the site power source. Basic guidelines include the following:

- Make sure each chassis power supply has its own dedicated branch circuit.
- Size the circuits according to local and national codes.
- If you are using a 200/240 VAC power source in North America, use a two-pole circuit breaker to protect the circuit.
- Place the source AC outlet within 6 feet (1.8 meters) of the system and make sure it is easily accessible.

- Make sure the AC power receptacles used to plug in the chassis are the grounding type. The grounding conductors that connect to the receptacles should connect to protective earth ground at the service equipment.

Four types of AC-input power supplies are available:

- 1000 W—Table 2-1 lists the AC-input power cord options, specifications, Cisco part numbers, and shows the different styles of 1000 W AC-input power cord wall plugs that are available for North America and international locations as well as the appliance coupler that is attached to the power supply end of the power cord.
- 1300 W—Table 2-1 lists the AC-input power cord options, specifications, and Cisco product numbers, and shows the different styles of 1300 W AC-input power cord wall plugs that are available for North America or various international locations as well as the appliance coupler that is attached to the power supply end of the power cord.




---

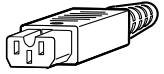
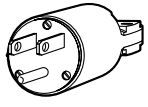
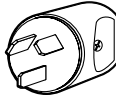
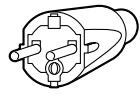
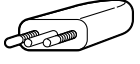


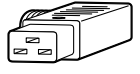
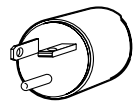
**Note** For North America, the power cord plug types and appliance couplers on the power supplies are different for the 1000 W power supplies and the 1300 W power supplies; for other countries, the plugs shown are the same for the 1000 W and 1300 W power supplies.

---

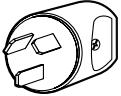
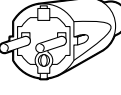
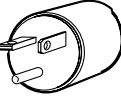
- 1400 W—Table 2-1 lists the AC-input power cord options, specifications, and Cisco product numbers, and shows the different styles of 1400 W AC-input power cord wall plugs that are available for North America or various international locations as well as the appliance coupler that is attached to the power supply end of the power cord.
- 2800 W—Table 2-1 lists the AC-input power cord options, specifications, and Cisco part numbers, and shows the different styles of 2800 W AC-input power cord wall plugs that are available for North America and international locations as well as the appliance coupler that is attached to the other end of the 2800 W power supply power cord.
- 4200 W—Table 2-1 lists the AC-input power cord options, specifications, and Cisco part numbers, and shows the different styles of 4200 W AC-input power cord wall plugs that are available for North America and international locations as well as the appliance coupler that is attached to the other end of the 4200 W power supply power cord.

The cable part numbers use standard conventions as shown in this example: CAB-L620P-C19-US. CAB-L means the cable will lock to the outlet. 620P means the cable is intended for a NEMA 220V 20 AMP circuit connection. C19 refers to the appliance side connector shape, rated for 20 Amps. US is the country the cable is intended for use in.

Table 2-1 AC-Input Power Cord Options

Locale	Part Number	Length	Plug Rating	Plug Type
<b>1000 W Power Supply (PWR-C45-1000AC=)</b>			<b>Appliance Coupler</b>	
				 120352
North America	CAB-7KAC=	8.2 ft (2.5 m)	125 VAC, 15 A	NEMA 5-15P  120354
Australia, New Zealand	CAB-7KACA=	8.2 ft (2.5 m)	250 VAC, 15 A	SAA/3, AS/NZS 3112-1993  120356
Europe (except Italy)	CAB-7KACE=	8.2 ft (2.5 m)	250 VAC, 16 A	CEE 7/7  120357
Italy	CAB-7KACI=	8.2 ft (2.5 m)	250 VAC, 16 A	1/3/16 CEI 23-16  120358
United Kingdom	CAB-7KACU=	8.2 ft (2.5 m)	250 VAC, 13 A	BS 89/13 BS 1363/A  120359
Argentina	CAB-7KACR=	8.2 ft (2.5 m)	250 VAC, 10 A	IRAM 2073  120356
<b>1300 W (PWR-C45-1300ACV=) and 1400 W (PWR-C45-1400AC=) Power Supplies</b>			<b>Appliance Coupler</b>	
				 120353
North America	CAB-7513AC=	14 ft (4.3 m)	125 VAC, 20 A	NEMA 5-20  120362

**Table 2-1 AC-Input Power Cord Options (continued)**

Locale	Part Number	Length	Plug Rating	Plug Type
Australia, New Zealand	CAB-7513ACA=	14 ft (4.3 m)	250 VAC, 15 A	SAA/3, AS/NZS 3112-1993  120356
Europe (except Italy)	CAB-7513ACE=	14 ft (4.3 m)	250 VAC, 16 A	CEE 7/7  120357
Italy	CAB-7513ACI=	14 ft (4.3 m)	250 VAC, 16 A	1/3/16, CEI 23-16  120358
United Kingdom	CAB-7513ACU=	14 ft (4.3 m)	250 VAC, 13 A	BS 89/13 BS 1363/A  120359
Argentina	CAB-7513ACR=	14 ft (4.3 m)	250 VAC, 10 A	IRAM 2073  120356
North America (locking) 200–240 VAC operation	CAB-AC-2800W-TWLK=	13.6 ft (4.1 m)	250 VAC, 16 A	NEMA L6-20  120361
North America (non-locking) 200–240 VAC operation	CAB-AC-2800W-6-20	13.2 ft (4.0 m)	250 VAC, 16 A	NEMA 6-20 non-locking  120355
Europe	CAB-AC-2800W-EU=	13.2 ft (4.0 m)	250 VAC, 16 A	CEE 7/7  120357



**Table 2-1 AC-Input Power Cord Options (continued)**

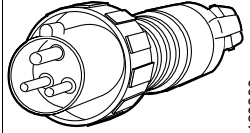

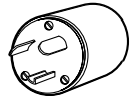
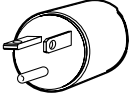
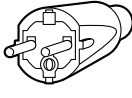
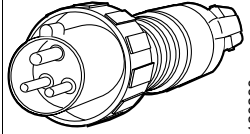

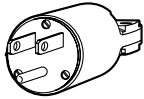
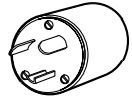
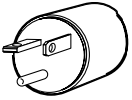
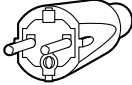
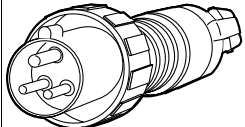
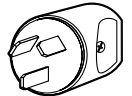
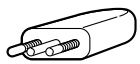

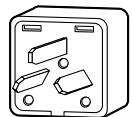
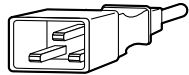
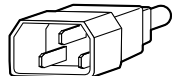
Locale	Part Number	Length	Plug Rating	Plug Type
International	CAB-AC-2800W-INT=	13.6 ft (4.1 m)	250 VAC, 16 A	IEC 309 
<b>Appliance Coupler</b> 				
<b>2800 W Power Supply (PWR-C45-2800ACV=)</b>				
North America (locking) 200–240 VAC operation	CAB-AC-2800W-TWLK=	13.6 ft (4.1 m)	250 VAC, 16 A	NEMA L6-20 
North America (non-locking) 200–240 VAC operation	CAB-AC-2800W-6-20	13.2 ft (4.0 m)	250 VAC, 16 A	NEMA 6-20 non-locking 
Europe	CAB-AC-2800W-EU=	13.2 ft (4.0 m)	250 VAC, 16 A	CEE 7/7 
International	CAB-AC-2800W-INT=	13.6 ft (4.1 m)	250 VAC, 16 A	IEC 309 
<b>Appliance Coupler</b> 				
<b>4200 W Power Supply (PWR-C45-4200ACV=)</b>				
North America 120 VAC operation	CAB-US515P-C19-US	9.8 ft (2.98 m)	125VAC, 15A	NEMA 5-15P 
North America (locking) 200–240 VAC operation	CAB-L620P-C19-US	14 ft (4.2 m)	250 VAC, 20 A	NEMA L6-20 

Table 2-1 AC-Input Power Cord Options (continued)

Locale	Part Number	Length	Plug Rating	Plug Type
North America (non-locking) 200–240 VAC operation	CAB-US620P-C19-US	13.2 ft (4.02 m)	250 VAC, 20 A	NEMA 6-20 non-locking  120355
Europe	CAB-CEE77-C19-EU	13.2 ft (4.0 m)	250 VAC, 15 A	CEE 7/7  120357
International (including Argentina and South Africa)	CAB-I309-C19-INT	13.6 ft (4.1 m)	250 VAC, 16 A	IEC 309  120360
Australia	CAB-A3112-C19-AUS	14 ft (4.3 m)	250 VAC, 15 A	AS/NZS 3112  120356
Italy	CAB-C2316-C19-IT	14 ft (4.3 m)	250 VAC, 16 A	CEI 23-16  120358
United Kingdom	CAB-BS1363-C19-UK	14 ft (4.3 m)	250 VAC, 15 A	BS 1363  120359
Israeli	CAB-S132-C19-ISRL	14 ft (4.3 m)	250 VAC, 16 A	SI32  130922
UPS 220V	CAB-C19-CBN	9 ft (2.74 m)	250 VAC, 20 A	IEC-60320-C20  130923
UPS 110V	CAB-C19-C14	14 ft (4.3 m)	125 VAC, 16 A	IEC-60320-C14  130924

# Power Connection Guidelines for DC-Powered Systems

This section provides the basic guidelines for connecting the Catalyst 4500 E-series switch compatible DC-input power supplies to the site power source or AC power shelf:

- All power connection wiring should conform to local and national codes.
- DC (–) and DC return (+) terminals are evaluated for use with 1/0 AWG wire (1400W DC supply only).
- The ground terminal is evaluated for use with 6 AWG wire (10 AWG for the multi-input power supply).
- DC (–) and DC return (+) wire lugs shall not exceed 0.83 inches in width (0.378 inches for the multi-input power supply).
- For DC power cables, we recommend that you use commensurately rated, high-strand-count copper wire cable. Connection to the DC-input power supply requires one earth ground cable, one source DC (–), and one source DC return (+). The length of the cables depends on your switch location. These cables are not available from Cisco Systems. They are available from any commercial cable vendor.
- The color coding of the source DC power cable leads depends on the color coding of the site DC power source. Typically, green or green and yellow indicate that the cable is a ground cable. Because there is no color code standard for source DC wiring, you must ensure that the power cables are connected to the DC-input power supply terminal block in the proper (+) and (–) polarity. In some cases, the source DC cable leads might have a positive (+) or a negative (–) label. This label is a relatively safe indication of the polarity, but you must verify the polarity by measuring the voltage between the DC cable leads. When making the measurement, the positive (+) lead and the negative (–) lead must always match the (+) and (–) labels on the DC-input power supply terminal block.

## Calculating DC Input Current

Complete power usage tables are in the *Catalyst 4500 Series Module Installation Guide*. To calculate the DC input current needed for data and inline power applications, use the following steps (the example shows the DC input current requirement in a Catalyst 4503-E with a Supervisor Engine II and two WS-X4306-GB modules, and assumes a DC input voltage of -48 VDC):

---

**Step 1** Add the power requirement for each component in your system.

- Catalyst 4503-E uses 54 W
- Supervisor Engine II+ uses 147 W
- WS-X4306-GB uses 2 X 47 = 94 W
- Total DC input power = 295 W

**Step 2** After the entries for all components have been added together, divide that number by the DC input voltage to determine the DC input current.

- Input current = 295 W/48 VDC = 6.14 A for data only.

Step 3 to Step 5 are for applications requiring inline power. If your configuration does not include inline power devices, the DC input current is the result of Step 2.

**Step 3** If you want to add an inline-capable module (WS-X4148-RJ45V) with 10 inline devices (such as IP Phones) to your system, calculate the DC output power sent to inline devices.

- $10 \times 6.3 \text{ W} = 63 \text{ W}$  for inline devices.
- 6.3 Watts is correct for a Cisco IP phone. Wattage consumption will depend on the inline device used.
- Step 4** Find the DC input power using the DC output power.
- $63/.96$  (efficiency) = 65 W of DC input power.
- Step 5** Divide the DC input power by the DC voltage input of  $-48 \text{ V}$  to find the DC input current used by inline devices.
- $65/48 = 1.4$  Amps for inline devices.
- Step 6** Add the DC input current used by data and the DC input current used by inline devices to find the total DC input current.
- Total DC input current =  $6.14 + 1.4 = 7.54 \text{ A}$ .
- 

## Ventilation

Planning a proper location for the switch and the layout of your equipment rack or wiring closet is essential for successful system operation. You should install the switch in an enclosed, secure area, ensuring that only qualified personnel have access to the switch and control of the environment. Equipment placed too close together or inadequately ventilated can cause system overtemperature conditions. In addition, poor equipment placement can make chassis panels inaccessible and difficult to maintain.

The switch operates as a standalone system mounted in a rack in a secure wiring closet. It requires a dry, clean, well-ventilated, and air-conditioned environment. To ensure normal operation, maintain ambient airflow. If the airflow is blocked or restricted, or if the intake air is too warm, an overtemperature condition can occur. The switch environmental monitor can then shut down the system to protect the system components.

To ensure normal operation and avoid unnecessary maintenance, plan your site configuration and prepare your site before installation. After installation, make sure the site maintains an ambient temperature of  $0$  to  $40^{\circ}\text{C}$  ( $32$  to  $104^{\circ}\text{F}$ ). It is essential to keep the area around the chassis as free from dust and foreign conductive material (such as metal flakes from nearby construction activity) as is possible.

Multiple switches can be rack-mounted with little or no clearance above and below the chassis. However, when mounting a switch in a rack with other equipment, or when placing it on the floor near other equipment, ensure that the exhaust from other equipment does not blow into the intake vent of the chassis.

Cooling air is drawn in through the right side of the chassis. Keep the right side clear of obstructions, including dust and foreign conductive material, and away from the exhaust ports of other equipment.

Appendix A, “Specifications,” lists the operating and nonoperating environmental site requirements for the switches. To maintain normal operation and ensure high system availability, maintain an ambient temperature and clean power at your site. The environmental ranges listed in Appendix A, “Specifications,” are those within which the switch will continue to operate; however, a measurement that approaches the minimum or maximum of a range indicates a potential problem. You can maintain normal operation by anticipating and correcting environmental anomalies before they exceed the maximum operating range.

## Calculating System Heat Dissipation

To calculate the expected heat dissipation from a switch, add the total amount of power drawn from power supply by the system's configuration, then divide the total amount of power by the efficiency of the power supply. Multiply the result by 3.415 to get the system heat dissipation in BTUs/hr.

First example (System without any powered devices):

Components	Output Power
1 - Catalyst 4506-E with fans	50 W
1 - Supervisor Engine IV	145 W
1 - WS-X4248-RJ45V with no phones	72 W
total output power	267 W
Total heat dissipated by system = $(267/.75) * 3.415 = 1215$ BTUs/hr	



### Note

All power supplies have different efficiencies, An average efficiency figure of 75% was chosen.

Second example (same system but this time with one IEEE class 3 device):

Components	Output Power
1 - Catalyst 4506-E with fans	50 W
1 - Supervisor Engine IV	145 W
1 - WS-X4248-RJ45V with no phones	72 W
1 - IEEE class 3 device	17.3 W
total output power	284 W
Total heat dissipated by system = $(284/.75) * 3.415 = 1293$ BTUs/hr	



### Note

Although a class 3 device needs 15.4 W to power up, 17.3 W need to be generated from the backplane in order to have 15.4 W at the switch port. 17.3 W comes from the WS-X4248-RJ45V DC-DC converter's efficiency (89%).

## Site-Planning Checklist

Table 2-2 lists the site-planning activities that you should complete before you install a Catalyst 4500 E-series switch. Completing each activity helps to ensure a successful switch installation.

Table 2-2 Site-Planning Checklist

Task No.	Planning Activity	Verified by	Time	Date
1	Space evaluation: <ul style="list-style-type: none"> <li>• Space and layout</li> <li>• Floor covering</li> <li>• Impact and vibration</li> <li>• Lighting</li> <li>• Maintenance access</li> </ul>			
2	Environmental evaluation: <ul style="list-style-type: none"> <li>• Ambient temperature</li> <li>• Humidity</li> <li>• Altitude</li> <li>• Atmospheric contamination</li> <li>• Airflow</li> </ul>			
3	Power evaluation: <ul style="list-style-type: none"> <li>• Input power type</li> <li>• Receptacle proximity to the equipment</li> <li>• Dedicated (separate) circuits for redundant power supplies</li> <li>• UPS for power failures</li> </ul>			
4	Grounding evaluation: <ul style="list-style-type: none"> <li>• Circuit breaker size</li> </ul>			
5	Cable and interface equipment evaluation: <ul style="list-style-type: none"> <li>• Cable type</li> <li>• Connector type</li> <li>• Cable distance limitations</li> <li>• Interface equipment (transceivers)</li> </ul>			
6	EMI evaluation: <ul style="list-style-type: none"> <li>• Distance limitations for signaling</li> <li>• Site wiring</li> <li>• RFI levels</li> </ul>			



# CHAPTER 3

## Installing the Switch in a Rack

---

  
Warning

---

**This unit is intended for installation in restricted access areas. A restricted access area can be accessed only through the use of a special tool, lock and key, or other means of security.**  
Statement 1017

---

  
Warning

---

**Only trained and qualified personnel should be allowed to install, replace, or service this equipment.**  
Statement 1030

---

  
Warning

---

**To prevent personal injury or damage to the chassis, never attempt to lift or tilt the chassis using the handles on modules (such as power supplies, fans, or cards); these types of handles are not designed to support the weight of the unit.** Statement 1032

---

This chapter describes how to install Catalyst 4500 E-series switches in a rack. For first-time installations, perform the procedures in the following sections in the order listed:

- Checking the Shipping Container Contents, page 3-1
- Rack-Mounting the Switch, page 3-2



Note

---

Before starting the installation procedures in this chapter, complete the site-planning checklist in Table 2-2 of Chapter 2, “Preparing for Installation.”

---



Note

---

For information on installing the supervisor engine and switching modules and verifying switch operation, refer to the *Catalyst 4500 Series Module Installation Guide*. For information on configuring the switching modules, refer to the software configuration guide for your switch and software release.

---

## Checking the Shipping Container Contents



Note

---

Do not discard the shipping cartons and poly bag when you unpack the switch. Flatten and store them. You will need the containers if you need to move or ship the switch in the future. Repacking instructions are provided in Appendix B, “Repacking a Switch.”

---

Follow these steps to check the contents of the shipping cartons:

- 
- Step 1** Check the contents of the accessories box against the Accessories Box Components Checklist and the packing slip that were included with your switch. Verify that you received all listed equipment, including the following:
- Switch hardware documentation and software documentation (if ordered)
  - Optional equipment that you ordered, such as network interface cables, transceivers, or special connectors
- Step 2** Check the switching modules in each slot. Ensure that the configuration matches the packing list and that all the specified interfaces are included.
- 

## Rack-Mounting the Switch

A standard rack-mount kit is included for mounting the switch in a standard 19-inch (48.3 cm) equipment rack with two unobstructed outer posts, with a nominal depth (between the front and rear mounting posts) of 19.25 inches (48.9 cm) and a maximum depth of 32 inches (81.3 cm). This kit is not suitable for racks with obstructions (such as a power strip) that could impair access to the field-replaceable units (FRUs) of the switch.

Alternatively, you can obtain a 23-inch rack-mount kit.

## Required Installation Tools

You will need the following tools and equipment to install the chassis in a rack:

- Number 1 and number 2 Phillips screwdrivers to tighten the captive installation screws on most systems
- 3/16-inch flat-blade screwdriver for the captive installation screws on the supervisor engine and switching modules on some systems
- Antistatic mat or antistatic foam in case you need to remove switching modules to troubleshoot the installation
- Rack-mount kit
- Tape measure
- Level
- Your own electrostatic discharge (ESD) grounding strap or the disposable ESD strap included with the system



## Rack-Mounting Catalyst 4500 E-series Switches

**Warning**

To prevent bodily injury when mounting or servicing this unit in a rack, you must take special precautions to ensure that the system remains stable. The following guidelines are provided to ensure your safety:

- This unit should be mounted at the bottom of the rack if it is the only unit in the rack.
- When mounting this unit in a partially filled rack, load the rack from the bottom to the top with the heaviest component at the bottom of the rack.
- If the rack is provided with stabilizing devices, install the stabilizers before mounting or servicing the unit in the rack. Statement 1006

**Note**

If you move a supervisor engine from a Catalyst 4500 series chassis to a Catalyst 4503-E chassis or Catalyst 4506-E chassis, it must use Cisco IOS Release 12.2(37)SG or later. Refer to the release note for software upgrade procedures if needed:

[http://www.cisco.com/en/US/docs/switches/lan/catalyst4500/release/note/OL\\_5184.html#wp305142](http://www.cisco.com/en/US/docs/switches/lan/catalyst4500/release/note/OL_5184.html#wp305142)

Follow these steps to install a Catalyst 4500 E-series switch in a rack:

**Step 1** Prepare for installation as follows:

- a. Place the chassis on the floor or on a sturdy table as close as possible to the rack. Leave enough clearance to allow you to move around the chassis.
- b. Use a tape measure to measure the depth of the rack. Measure from the outside of the front mounting posts to the outside of the rear mounting strip. The depth must be at least 19.25 inches (48.9 cm) but not greater than 32 inches (81.3 cm).
- c. Measure the space between the inner edges of the left front and right front mounting posts to ensure that it is 17.75 inches (45.09 cm) wide. (The chassis is 17.25 inches [43.8 cm] wide and must fit between the mounting posts.)

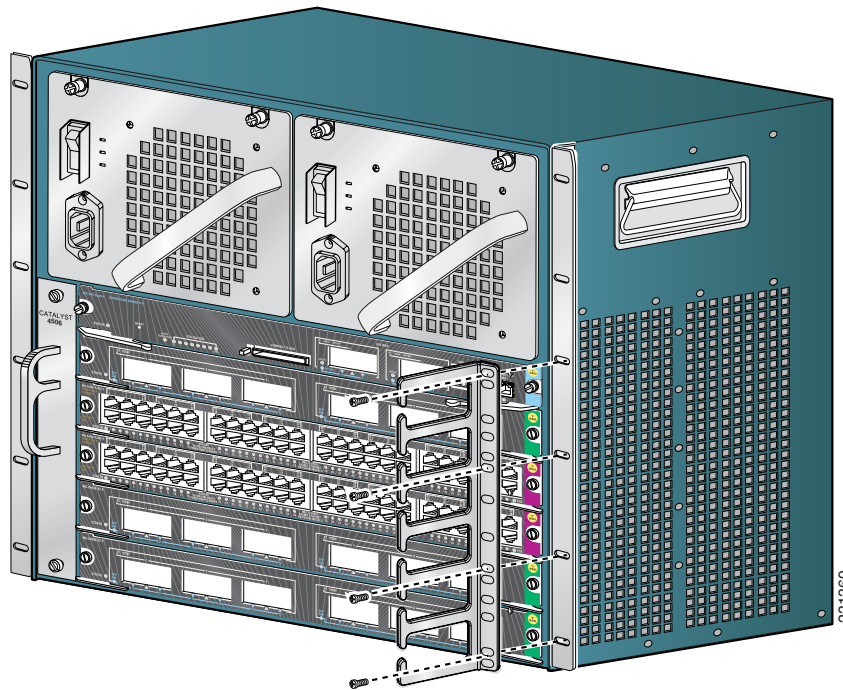
**Note**

Some equipment racks provide a power strip along the length of one of the rear posts. If your rack has this feature, consider the position of the strip when planning fastener points. Before installing the L brackets on the chassis, determine whether to install the chassis from the front or the rear of the rack.

- d. Attach the cable guide, if needed, using the M3 screws provided in the cable management kit. The cable guide attaches to the L bracket. Attach the cable guide to the right side of the switch to prevent the cables from obscuring module LEDs.

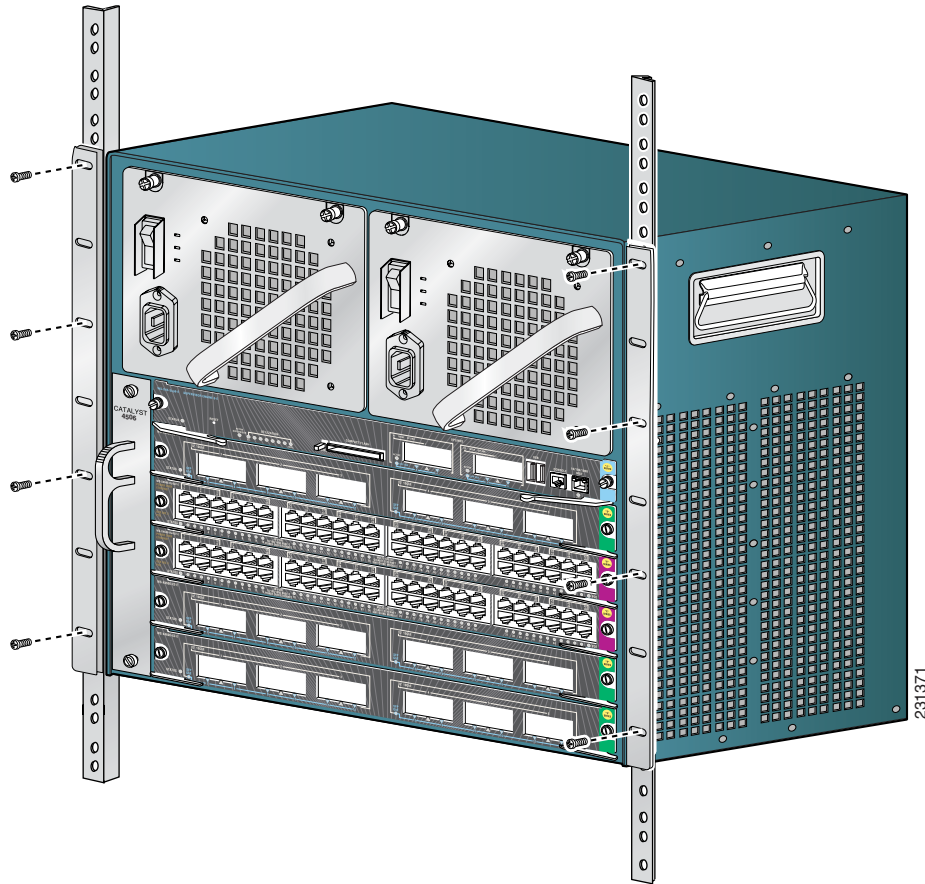
See Figure 3-1 for the Catalyst 4506-E switch, the other switches will be very similar.

**Figure 3-1** Attaching the Cable Guide to the Catalyst 4506-E Switch



- Step 2** Install the chassis in the rack as follows:
- a. Insert the rear of the chassis between the mounting posts.  
See Figure 3-2 to see how to install a Catalyst 4506-E switch in a rack. Other switches in the series mount in the same manner.
  - b. Align the mounting holes in the L bracket with the mounting holes in the equipment rack.
  - c. Secure the chassis using at least six (three per side) 12-24 x 3/4-inch screws through the elongated holes in the L bracket and into the threaded holes in the mounting post.
  - d. Use a tape measure and level to ensure that the chassis is installed straight and level.

**Figure 3-2** Installing a Catalyst 4506-E Switch in the Rack



- Step 3** Make sure that the ejector levers are completely closed and the supervisor engine and switching modules are installed securely.
- Step 4** Tighten any loose captive installation screws on the supervisor engine and the switching module.
- Step 5** Connect fiber and copper cables for switching traffic and uplinks or PoE as appropriate.
- Step 6** Connect the switch to an appropriate ground. Refer to System Ground Connection Guidelines, page 3-5. The system must have a ground connection before power is supplied to the switch.

## System Ground Connection Guidelines

A grounding pad with two system (earth) grounding holes is provided in an enclosure near the left power supply (PS1) on the Catalyst 4500 E-series switches (See Figure 3-3).

## Parts and Required Tools

**Note**

Some parts and required tools described in this section are not available from Cisco Systems. The grounding lug and associated screws are included with the accessory kit.

To make an adequate grounding connection, you will need the following parts and tools:

- Grounding lug—The grounding lug has two #10 AWG holes spaced 0.63 in center to center. A Panduit LCDX6-10A-L or Pencom EL1033 lug may be used if the lug from the accessory kit has been misplaced.
- Two M4 (metric) hex-head screws.
- One grounding wire (6 AWG recommended)—The length of the grounding wires depends on the location of your switch within the site and its proximity to proper grounding facilities.
- Number 2 Phillips screwdriver.
- Crimping tool—This tool must be large enough to accommodate the girth of the grounding lug when you crimp the grounding cable into the lug.
- Wire-stripping tool.

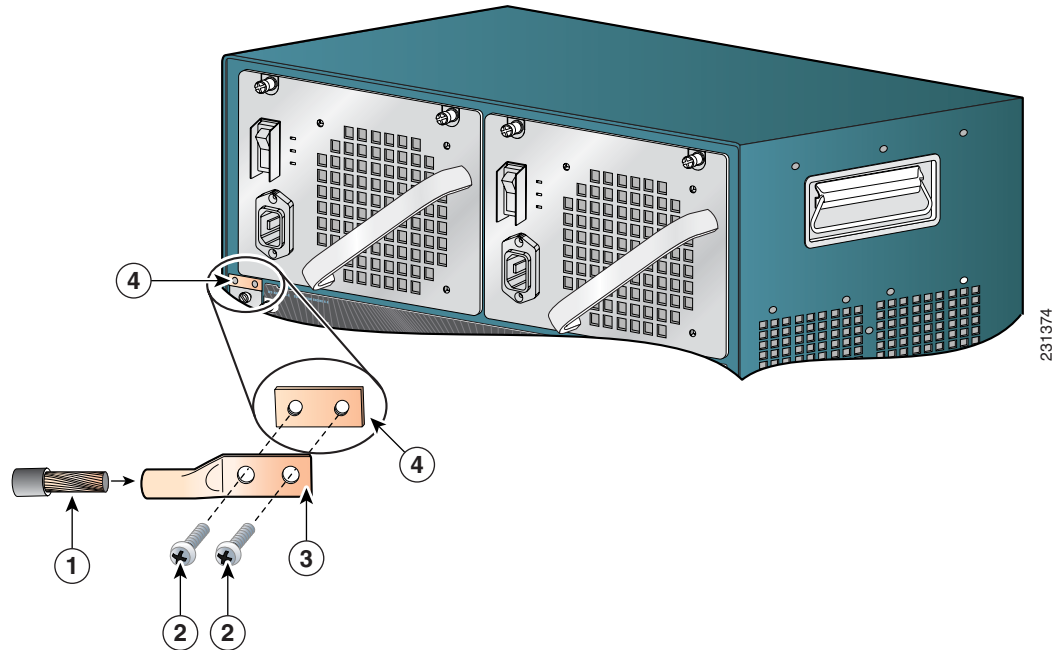
## Connecting System Ground and Power

This section describes how to connect the Catalyst 4500 E-series switches to earth ground. The system ground connection is required if FXS modules are installed or if this equipment is installed in a US or European Central Office. You must complete this procedure before connecting system power or turning on your switch.

To attach the grounding lug and cable to the grounding pad on your Catalyst 4500 E-series switch, perform the following steps:

- Step 1** Using a wire-stripping tool, remove approximately 0.75 inches (19 mm) of the covering from the end of the grounding wire.
- Step 2** Insert the stripped end of the grounding wire into the open end of the grounding lug (Figure 3-3).
- Step 3** Using a crimping tool, secure the grounding wire in place in the grounding lug.
- Step 4** Locate the grounding pad on the switch. (See Figure 3-3).

Figure 3-3 Connecting System Ground on the Switch



1	Grounding wire	4	Grounding pad
2	Screws (M4)		
3	Grounding lug		

**Step 5** Remove the label that covers the grounding pad.

**Step 6** Place the grounding lug against the grounding pad, aligning the holes. Insert the two M4 screws through the holes in the grounding lug and grounding pad.

Ensure that the grounding lug and the attached wire will not interfere with other switch hardware or rack equipment.

**Step 7** Tighten the screws to secure the grounding lug to the grounding pad.

**Step 8** Repeat steps 1 through 3 to prepare the other end of the grounding wire and connect it to an appropriate grounding point at your site to ensure adequate earth ground for the switch.

**Step 9** Connect the power supply cords. DC power supplies will have a separate ground connection, both chassis and power supply grounds are needed for the system. The switch comes on when the cords are connected and the power supply on/off switch is on.



**Note** This equipment is suitable for connection to intra-building wiring only.



**Note** If you are using a DC power supply, the DC return connection to this system should remain isolated from the system frame and chassis (DC-I).

This completes the installation of the Catalyst 4500 E-series switches.

**Note**

If you move a supervisor engine from a Catalyst 4500 series chassis to a Catalyst 4503-E chassis or Catalyst 4506-E chassis, it must use Cisco IOS Release 12.2(37)SG or later. Refer to the release note for software upgrade procedures if needed:

[http://www.cisco.com/en/US/docs/switches/lan/catalyst4500/release/note/OL\\_5184.html#wp305142](http://www.cisco.com/en/US/docs/switches/lan/catalyst4500/release/note/OL_5184.html#wp305142)

At this point you should use the RJ-45-to-RJ-45 rollover cable to connect the console port to a PC that runs terminal emulation software. Configure your terminal emulation program for 9600 baud, 8 data bits, no parity, no flow control, and 1 stop bit. With this console connection, you can configure the switch as described in Appendix C, “Initial Configuration for the Switch,” and then as discussed in the software configuration guide appropriate for your switch’s software release, and monitor the software as the switch goes through its startup routine. The pinout for the console port is detailed in the module installation guide at:

<http://www.cisco.com/en/US/docs/switches/lan/catalyst4500/hardware/module/guide/0aspecs.html#wp1003825>



## CHAPTER 4

# Removing and Replacing FRUs

---

  
Warning

**Read the installation instructions before connecting the system to the power source.** Statement 1004

---

  
Warning

**Only trained and qualified personnel should be allowed to install, replace, or service this equipment.** Statement 1030

---

  
Warning

**This equipment must be grounded. Never defeat the ground conductor or operate the equipment in the absence of a suitably installed ground conductor. Contact the appropriate electrical inspection authority or an electrician if you are uncertain that suitable grounding is available.** Statement 1024

---

  
Warning

**Before working on equipment that is connected to power lines, remove jewelry (including rings, necklaces, and watches). Metal objects will heat up when connected to power and ground and can cause serious burns or weld the metal object to the terminals.** Statement 43

---

  
Warning

**Ultimate disposal of this product should be handled according to all national laws and regulations.** Statement 1040

---

This chapter tells you how to remove and replace Catalyst 4500 E-series field-replaceable units (FRUs). The information is presented in these sections:

- Removing and Replacing the Power Supply, page 4-2
- Removing and Replacing the Chassis Fan Assembly, page 4-13
- Replacing Backplane Modules, page 4-15

For instructions on installing and replacing supervisor engine and switching modules, refer to the *Catalyst 4500 Series Module Installation Guide*.

# Removing and Replacing the Power Supply

This section describes how to remove and install the AC-input power supply and DC-input power supply for the Catalyst 4500 E-series switches. This information is presented in the following sections:

- Required Tools, page 4-4
- Removing an AC-Input Power Supply, page 4-4
- Installing an AC-Input Power Supply, page 4-6
- Removing a DC-Input Power Supply, page 4-8
- Installing a DC-Input Power Supply, page 4-11



## Warning

**Hazardous voltage or energy is present on the backplane when the system is operating. Use caution when servicing.** Statement 1034

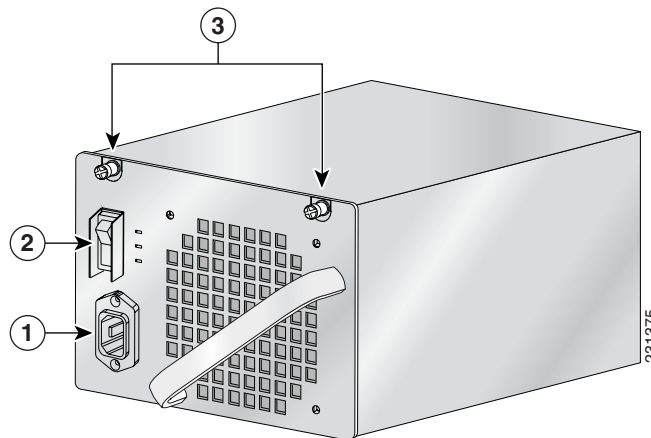
Figure 4-1 and Figure 4-2 show the AC-input power supplies. Figure 4-3 and Figure 4-4 show a the DC-input power supplies. Locate your power supply and notice the location of the captive installation screws.



## Note

The power supplies are hot-swappable, so in redundant mode you will not need to power down the switch to replace or upgrade most power supplies. In combined mode some slots may lose power during an upgrade or power supply replacement.

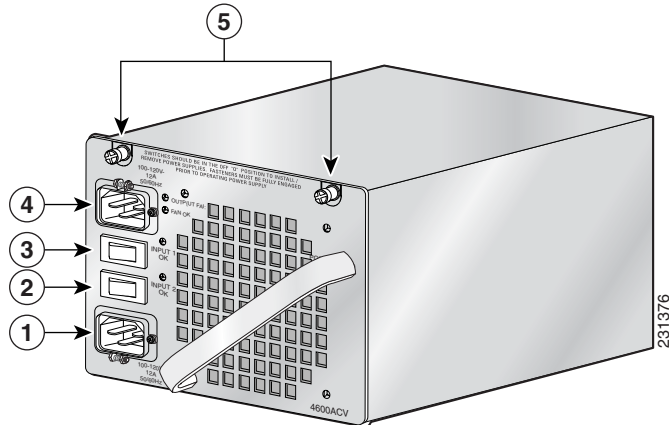
**Figure 4-1 AC-Input Power Supply**



1	AC receptacle	3	Captive screws
2	Power switch		

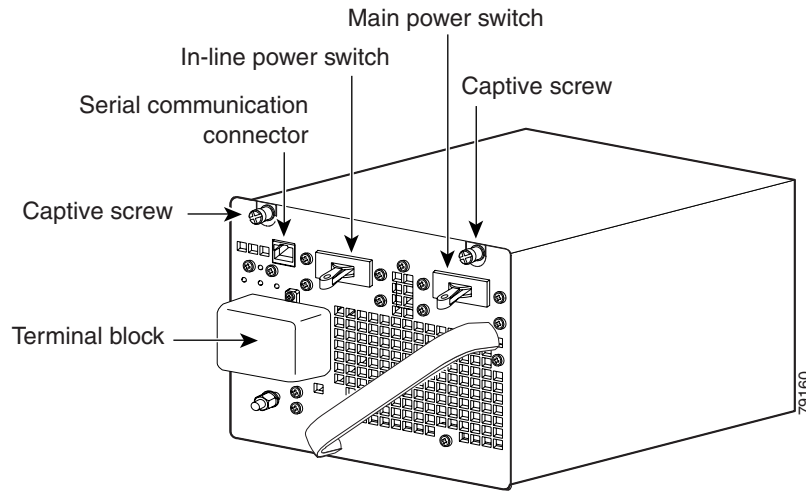


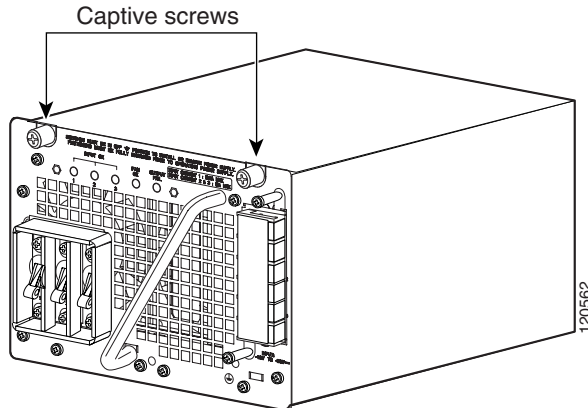
**Figure 4-2 4200 W Dual-Input AC Power Supply**



<b>1</b>	AC input 2 receptacle	<b>4</b>	AC input 1 receptacle
<b>2</b>	AC input 2 on switch	<b>5</b>	Captive screws
<b>3</b>	AC input 1 on switch		

**Figure 4-3 DC-Input Power Supply**



**Figure 4-4** 1400 W DC Triple-input Power Supply

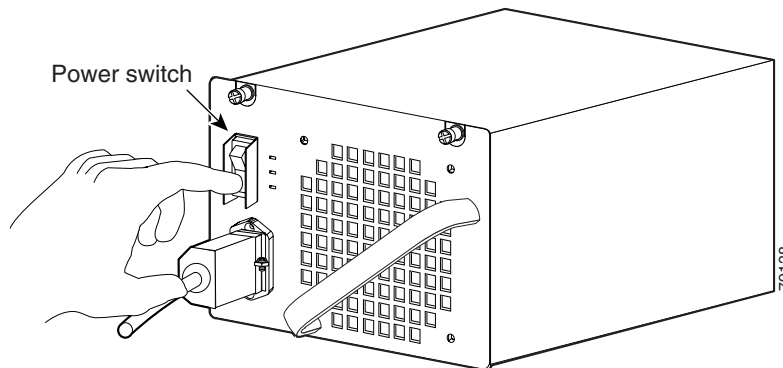
## Required Tools

You will need a flathead or Phillips screwdriver to perform these procedures.

## Removing an AC-Input Power Supply

Follow these steps to remove the AC-input power supply:

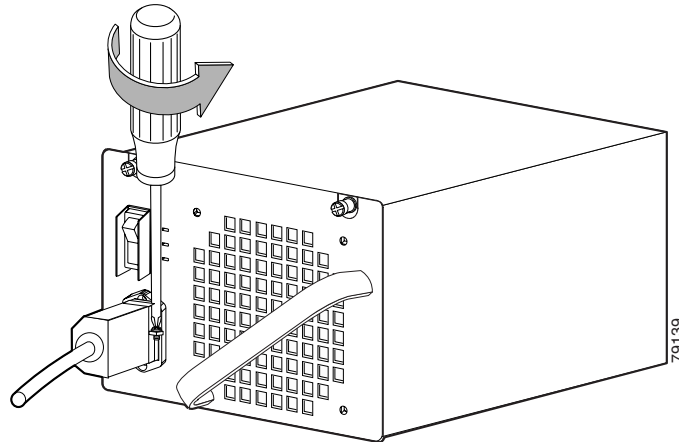
- Step 1** Press the power switch on the AC-input power supply down to the off (O) position (see Figure 4-5).

**Figure 4-5** Powering Off the Power Switch

**Note** There are two on/off switches on a 4200 W AC power supply, one for each input.

- Step 2** Loosen the side-clamp screw on the right side of the power cord plug (see Figure 4-6).

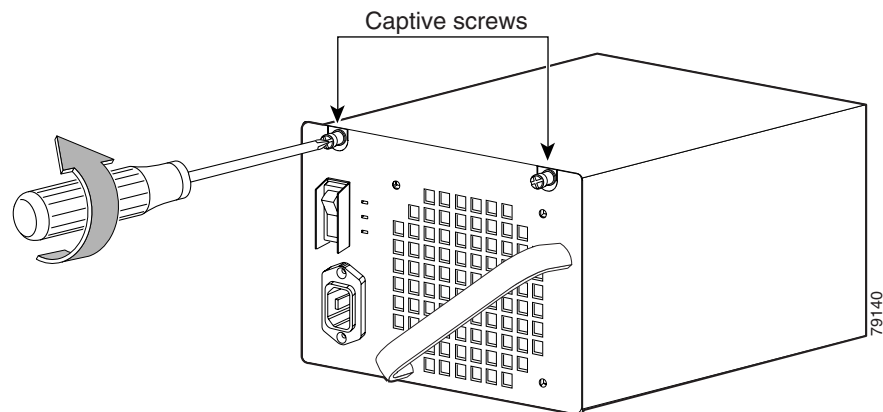
**Figure 4-6** Loosening the Side-Clamp Screw



**Step 3** Disconnect the power cord from the power supply being removed.

**Step 4** Loosen the two captive screws (see Figure 4-7).

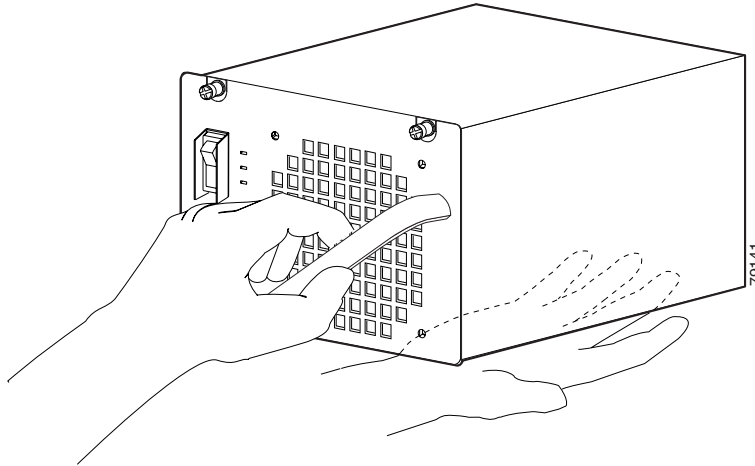
**Figure 4-7** Loosening the Captive Screws



**Caution** Use both hands to grasp a power supply.

**Step 5** Grasp the power supply handle with one hand. Place your other hand underneath to support the bottom of the power supply, as shown in Figure 4-8.

Figure 4-8 Handling an AC-Input Power Supply



**Step 6** Pull the power supply out of the bay and set it aside.

**Warning**

**Blank faceplates and cover panels serve three important functions: they prevent exposure to hazardous voltages and currents inside the chassis; they contain electromagnetic interference (EMI) that might disrupt other equipment; and they direct the flow of cooling air through the chassis. Do not operate the system unless all cards, faceplates, front covers, and rear covers are in place.**

Statement 1029

**Step 7** If the power supply bay is to remain empty, install a blank power supply filler plate over the opening. Secure the filler plate with the two mounting screws and tighten them with a screwdriver.

## Installing an AC-Input Power Supply

**Warning**

**The plug-socket combination must be accessible at all times, because it serves as the main disconnecting device.** Statement 1019

Follow these steps to install an AC-input power supply:

**Step 1** Make sure that the power supply you are installing is not plugged in to a power outlet and that the power cord is not connected to the power supply.

**Step 2** Remove the two Phillips-head screws from the power supply filler plate (if a filler plate is present).

**Step 3** Remove the power supply filler plate (if one is present) and set it aside.

**Caution**

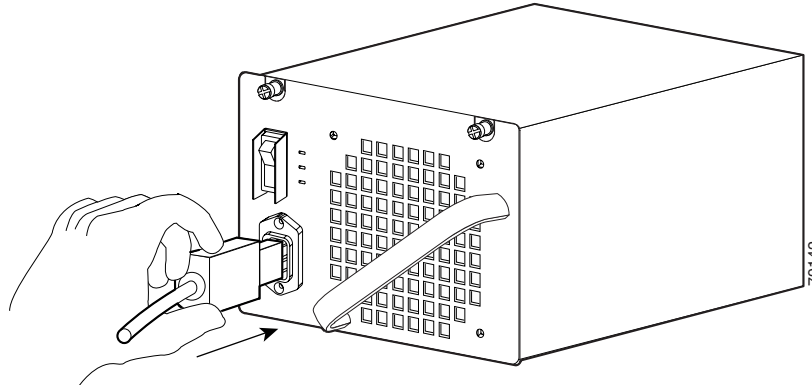
Use both hands to grasp a power supply.

**Step 4** Grasp the power supply handle with one hand. Place your other hand underneath to support the bottom of the power supply, as shown earlier in Figure 4-8.

**Step 5** Slide the power supply all the way into the power supply bay.

- Step 6** Using a screwdriver, tighten the two captive installation screws (see Figure 4-1) on the front panel of the AC-input power supply.
- Step 7** Make sure the power supply power switch is in the off position (O).
- Step 8** Before you connect the power supply to a power source, ensure that all site power and grounding requirements have been met.
- Step 9** Plug the power cord into the power supply (see Figure 4-9).

**Figure 4-9** *Plugging the Power Cord into the Power Supply*



- Step 10** Connect the other end of the power cord to an AC-power input source.

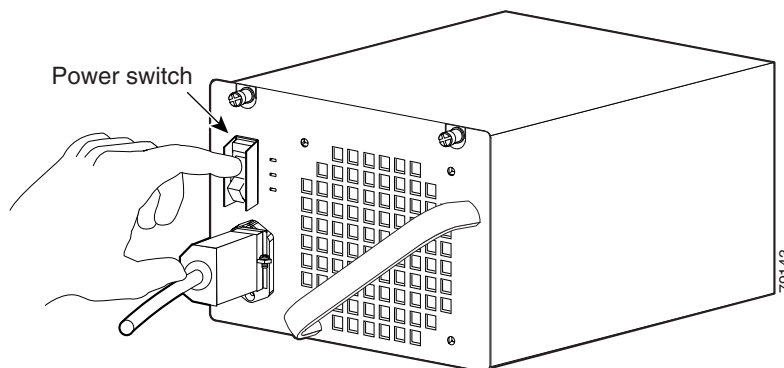


**Caution**

In a system with multiple power supplies, connect each power supply to a separate AC power source. In the event of a power source failure, if the second source is still available, it can maintain maximum overcurrent protection for each power connection.

- Step 11** Press the power switch down to the on (I) position (see Figure 4-10).

**Figure 4-10** *Powering On the Power Supply*



- Step 12** Verify power supply operation by checking the power supply's front-panel LEDs. You should see the following:
- The LED labeled GOOD is green.
  - The LED labeled FAIL is not lit.
  - The LED labeled FAN OK is green.

- Step 13** Check the power supply and system status from the system console by entering **show power** command. For more information on this command, refer to the command reference publication for your switch.
- Step 14** If the LEDs or **show power** command output indicate a power problem or other system problem, see Chapter 5, “Troubleshooting,” for more information.
- 

## Removing a DC-Input Power Supply

This section describes how to remove a DC-input power supply.

### Required Tools

You will need the following tools to perform this procedure:

- A Phillips screwdriver
- A 10-mm wrench/socket

### Removal Procedure



#### Warning

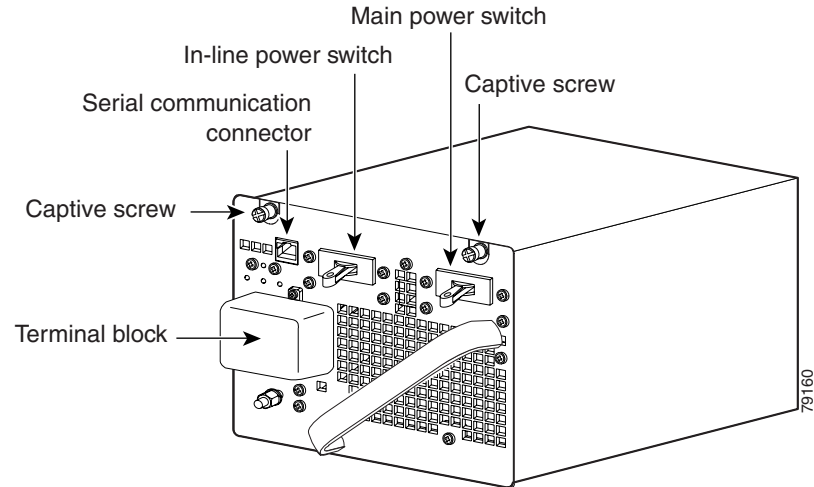
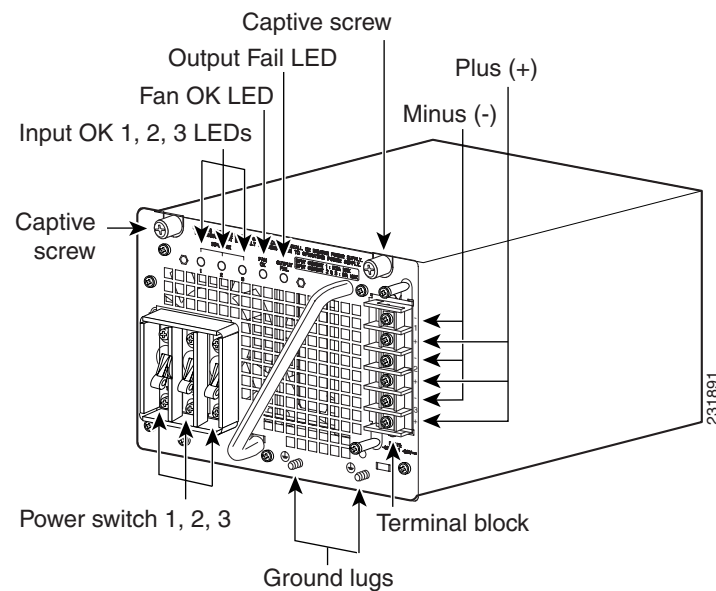
---

**Before performing any of the following procedures, ensure that power is removed from the DC circuit.**  
Statement 1003

---

Follow these steps to remove a DC-input power supply:

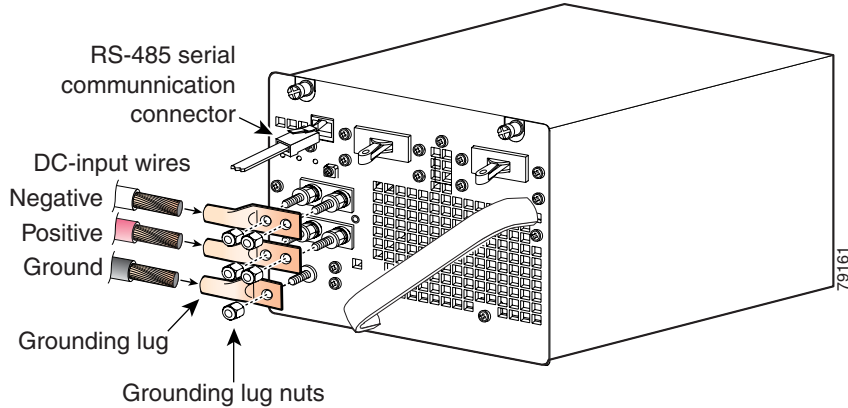
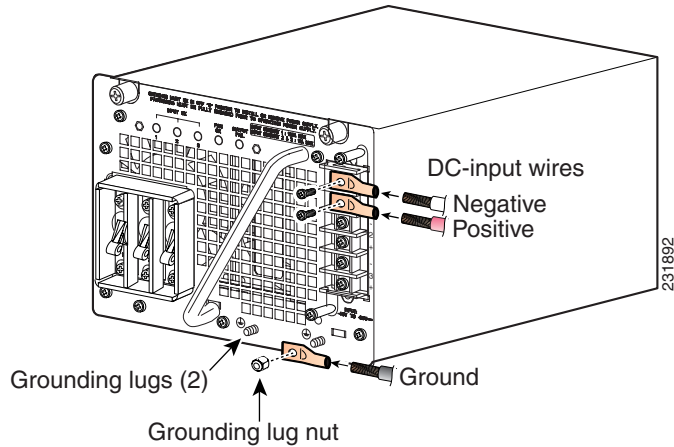
- 
- Step 1** Turn off the in-line power switch. (Single input only. The triple-input power supply does not have this switch.)
- Step 2** Turn off the main power switch.
- Step 3** Verify that power is off to the DC circuit on the power supply you are removing.
- Step 4** Loosen the screw on the terminal block cover and remove it from the terminal block (see Figure 4-11 or Figure 4-12). The triple-input power supply has two screws on the cover.

**Figure 4-11 DC-Input Power Supply****Figure 4-12 DC Triple-input Power Supply**

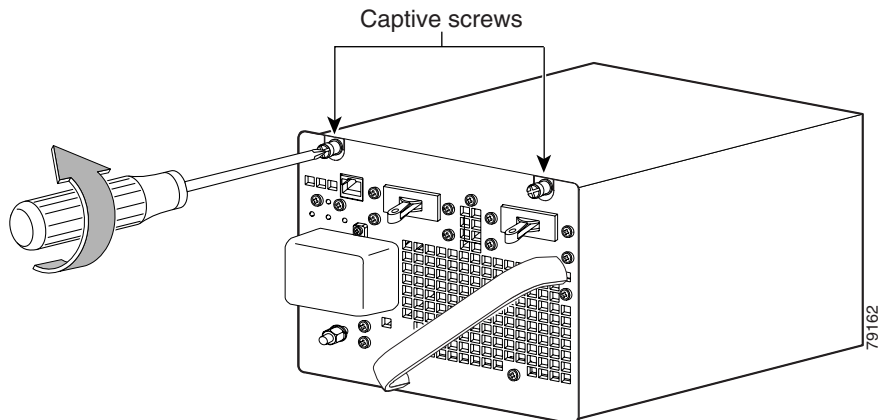
**Step 5** Disconnect the DC-input wires from the terminal block. Disconnect the ground wire last (see Figure 4-13 or Figure 4-14).

**Warning**

**When installing or replacing the unit, the ground connection must always be made first and disconnected last.** Statement 1046

**Figure 4-13** Connecting the DC-Input Wires**Figure 4-14** Connecting the DC-Input Wires (Triple-input Power Supply)

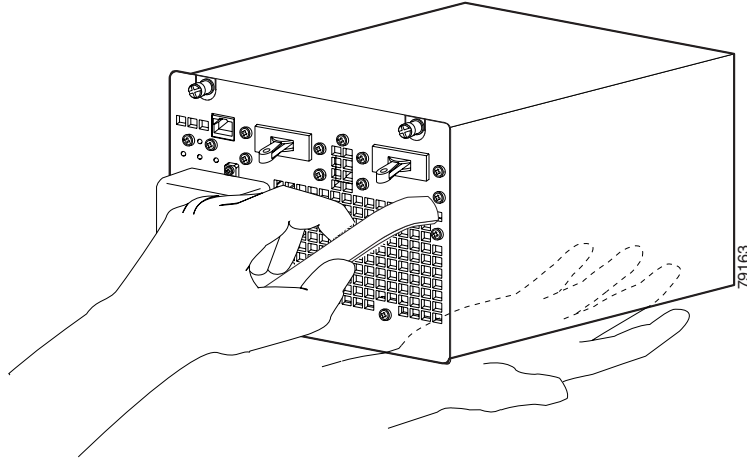
- Step 6** Using a screwdriver, loosen and remove the captive screws on the power supply. (See Figure 4-15, which shows the single input power supply. The triple-input power supply has captive screws in the same location.)

**Figure 4-15** Loosening the Captive Screws



- Step 7** Grasp the power supply handle with one hand. Place your other hand underneath as you slowly pull the power supply out of the bay (see Figure 4-16).

**Figure 4-16** Handling a DC-Input Power Supply



- Step 8** If the bay is to remain empty, install a blank power supply filler plate over the opening and secure it with the mounting screws. This protects the inner chassis from dust and prevents accidental contact with live voltage at the rear of the bay.



**Warning**

**Blank faceplates and cover panels serve three important functions: they prevent exposure to hazardous voltages and currents inside the chassis; they contain electromagnetic interference (EMI) that might disrupt other equipment; and they direct the flow of cooling air through the chassis. Do not operate the system unless all cards, faceplates, front covers, and rear covers are in place.** Statement 1029

## Installing a DC-Input Power Supply

This section describes how to install a DC-input power supply.

### Required Tools

You will need the following tools to perform this procedure:

- A Phillips screwdriver
- A 10-mm wrench/socket
- Connectors and wire for the DC circuit or circuits

## Installation Procedure



**Warning**

**Before performing any of the following procedures, ensure that power is removed from the DC circuit.** Statement 1003



**Warning**

**A readily accessible two-poled disconnect device must be incorporated in the fixed wiring.** Statement 1022



**Warning**

**This product requires short-circuit (overcurrent) protection, to be provided as part of the building installation. Install only in accordance with national and local wiring regulations.** Statement 1045



**Warning**

**Use copper conductors only.** Statement 1025



**Warning**

**When stranded wiring is required, use approved wiring terminations, such as closed-loop or spade-type with upturned lugs. These terminations should be the appropriate size for the wires and should clamp both the insulation and conductor.** Statement 1002

Follow these steps to install a DC-input power supply, connect it to a power source, and verify its operation:

- Step 1** Verify that power is off to the DC circuit or circuits on the power supply you are installing.
- Step 2** Grasp the power supply handle with one hand. Place your other hand underneath it as you slowly insert the power supply into the bay (as shown earlier in Figure 4-16).
- Step 3** Using a screwdriver, tighten the captive screws on the power supply (see Figure 4-15).
- Step 4** Before you connect the power supply to a power source, ensure that all site power and grounding requirements have been met.
- Step 5** Connect the DC-input wires to the power supply terminal block. The proper wiring sequence is ground to ground, positive to positive, and negative to negative (see Figure 4-13 or Figure 4-14 depending on your installation).

The 1400W triple-input power supply has two grounding posts; use the one that is most convenient for your installation.



**Warning**

**When installing or replacing the unit, the ground connection must always be made first and disconnected last.** Statement 1046

- Step 6** Replace the terminal cover.
- Step 7** Connect the other end of the power cords to a DC-power input source.

**Caution**

In a system with multiple power supplies or a single triple-input power supply, connect each power supply to a separate DC power source. In the event of a power source failure, if the second source is still available, it can maintain maximum overcurrent protection for each power connection.

- Step 8** Verify power supply operation by checking the power supply's front-panel LEDs. You should see the following:
- The LED labeled INPUT OK is green.
  - The LED labeled OUTPUT FAIL is not lit.
- Step 9** Check the power supply and system status from the system console by entering the **show power** command. For more information on the commands, refer to the command reference publication for your switch and software.
- Step 10** If the LEDs or the **show power** command (Cisco IOS) output indicate a power problem or other system problem, see Chapter 5, "Troubleshooting," for more information.

## Removing and Replacing the Chassis Fan Assembly

This section describes how to remove and install the chassis fan assembly for the Catalyst 4500 E-series switches. See Figure 4-17 for the Catalyst 4506-E system fan assembly, other fan assemblies attach in a very similar way.

### Required Tools

You will need a Phillips screwdriver for the following two procedures.

### Removing the Fan Assembly

**Warning**

**When removing the fan tray, keep your hands and fingers away from the spinning fan blades. Let the fan blades completely stop before you remove the fan tray.** Statement 258

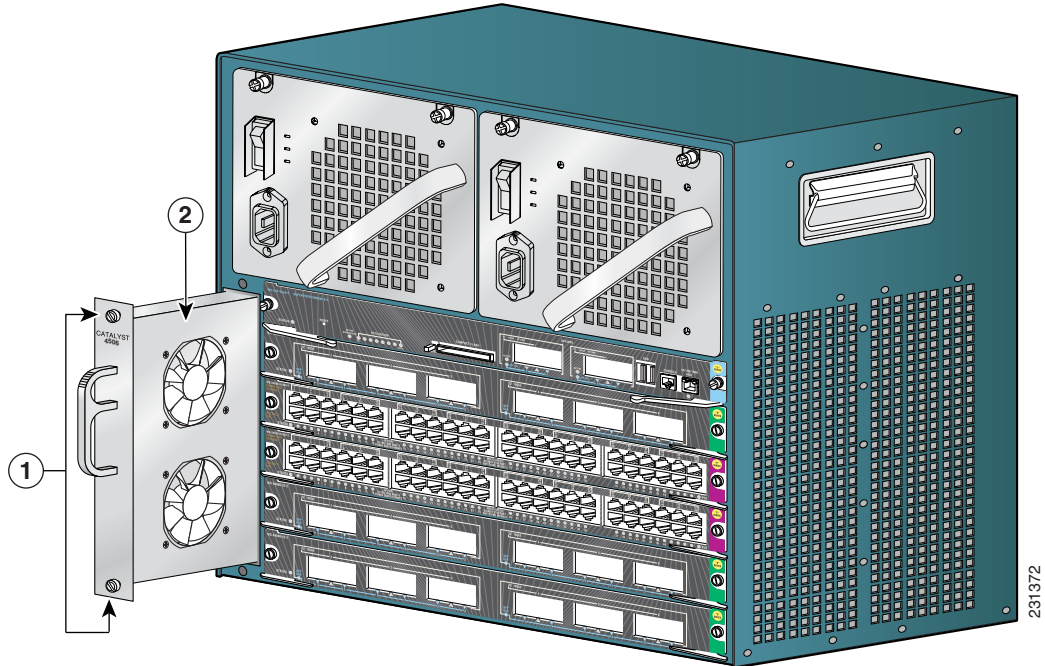
**Caution**

Never operate the system for an extended period if the fan assembly is removed or if it is not functioning properly. An over-temperature condition can cause severe equipment damage.

Follow these steps to remove the existing chassis fan assembly:

- Step 1** Loosen the two captive installation screws on the fan assembly by turning them counterclockwise.

Figure 4-17 Catalyst 4506-E System Fan Assembly



1	Captive installation screws	2	Fan assembly
---	-----------------------------	---	--------------

- Step 2** Grasp the fan assembly with both hands and pull it outward; gently move it side to side if necessary to unseat it from the backplane. Slide it out of the chassis and place it in a safe place.

## Installing the Fan Assembly

Follow these steps to install the new fan assembly:

- Step 1** Hold the fan assembly with the fans facing to the right.
- Step 2** Place the fan assembly into the fan assembly bay so it rests on the chassis, and then lift the fan assembly up slightly, aligning the top and bottom guides.
- Step 3** Slide the fan assembly into the chassis until the two captive installation screws make contact with the chassis.
- Step 4** Using a screwdriver, tighten the two captive installation screws by turning them clockwise.

## Verifying the Installation

**Note**

To check the operation of the fans, you need to power up the chassis.

Follow these steps to verify that the new fan assembly was installed correctly:

- Step 1** Listen for the fans; you should immediately hear them operating. If you do not hear them, ensure that the fan assembly is inserted completely in the chassis and that the faceplate is flush with the switch back panel.
- Step 2** The fan tray LED should light and be green.
- Step 3** If after several attempts the fans do not operate, or if you experience trouble with the installation (for instance, if the captive installation screws do not align with the chassis holes), contact the Cisco TAC for assistance.

## Replacing Backplane Modules

There are 5 redundancy modules (also called mux buffers) and 1 clock module on a Catalyst 4507R-E chassis backplane. A Catalyst 4510R-E has 8 redundancy modules on its backplane. They are accessible from the front if the switching modules and supervisor engines are removed. There are two types of redundancy modules, and they are interchangeable.

The clock module replacement procedure is identical to the redundancy module replacement procedure, the connectors are the same. These modules are not hot-swappable, the switch must be taken out of service to replace them.

To replace the backplane modules:

- Step 1** Make sure you are grounded with an ESD strap.
- Step 2** Turn off the power to the chassis.
- Step 3** Remove all supervisor engines and switching modules from the chassis, and find the backplane modules you need to replace.

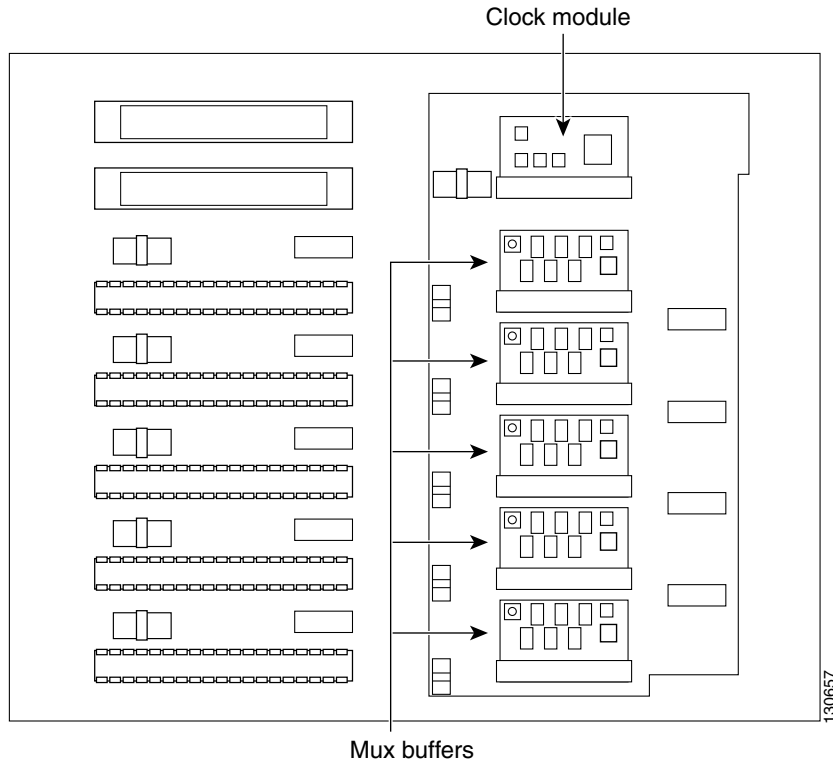
**Note**

Keep a record of switching module and their slots, so that you can put them back correctly.

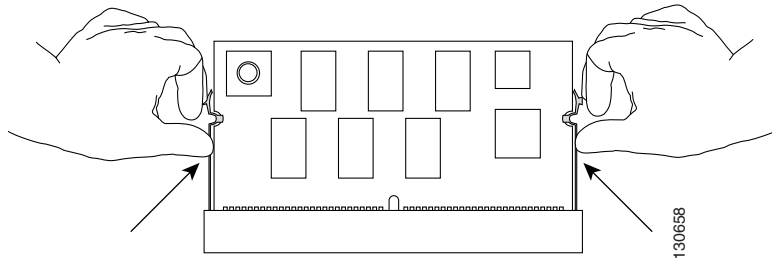
**Note**

Generic switching module replacement procedures are documented at:  
[http://www.cisco.com/en/US/docs/switches/lan/catalyst4500/hardware/configuration/notes/gMdCf\\_nt.html](http://www.cisco.com/en/US/docs/switches/lan/catalyst4500/hardware/configuration/notes/gMdCf_nt.html)

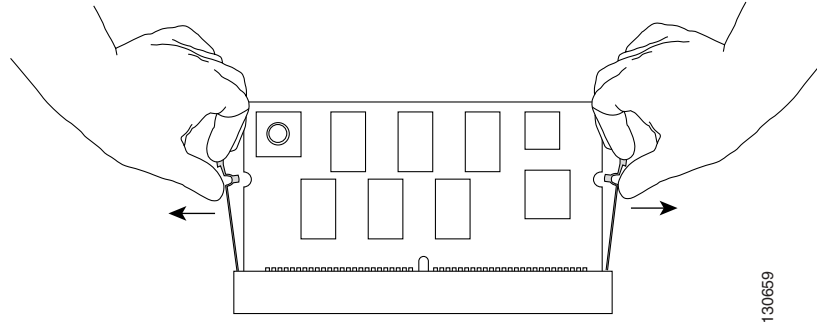
Figure 4-18 shows the front view of the backplane with supervisors and switching modules removed.

**Figure 4-18 Catalyst 4507R-E Backplane**

- Step 4** If you are removing a clock module, remove the two screws that attach the module to the backplane.
- Step 5** Find the seating levers on both sides of the connector for the module you wish to replace. (See Figure 4-19.)

**Figure 4-19 Finding the Seating Levers**

- Step 6** To release the module from its connector, pull the levers outward with your fingernails. The module will pop out slightly. (See Figure 4-20.)

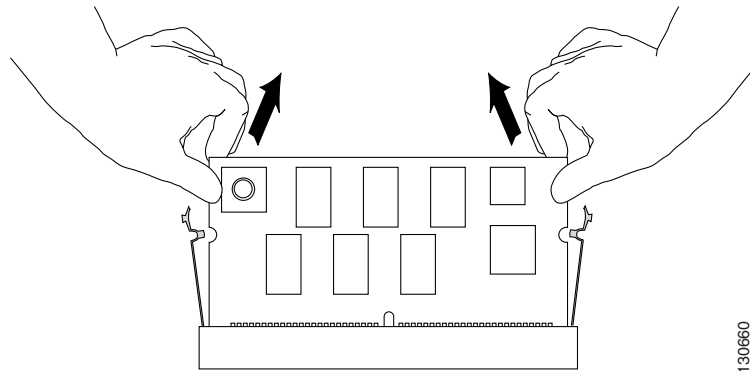
**Figure 4-20** *Releasing the Module*

130659

**Step 7** Pull out the module while holding the top left and top right corners. (See Figure 4-21.)

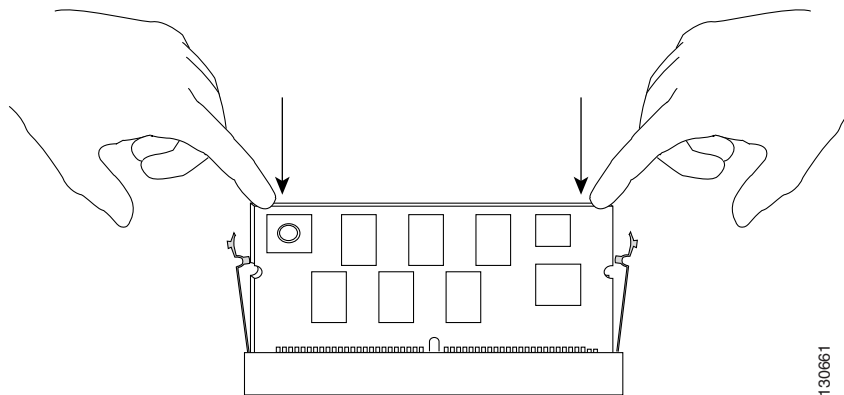


**Note** When handling the modules, do not touch the chips or the gold edge contacts on the module.

**Figure 4-21** *Removing the Module*

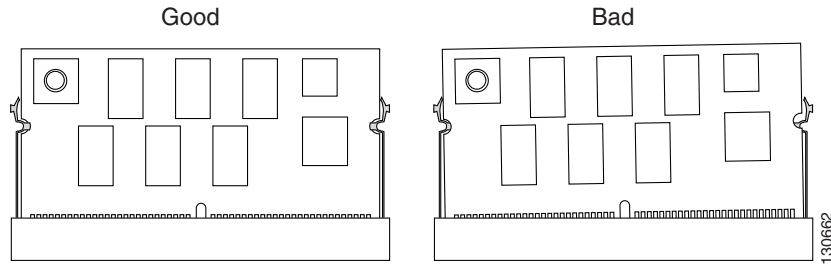
130660

**Step 8** Put the replacement module in at roughly a 30 degree angle, and gently push the module down. Make sure you apply force evenly on the left and right. (See Figure 4-22.)

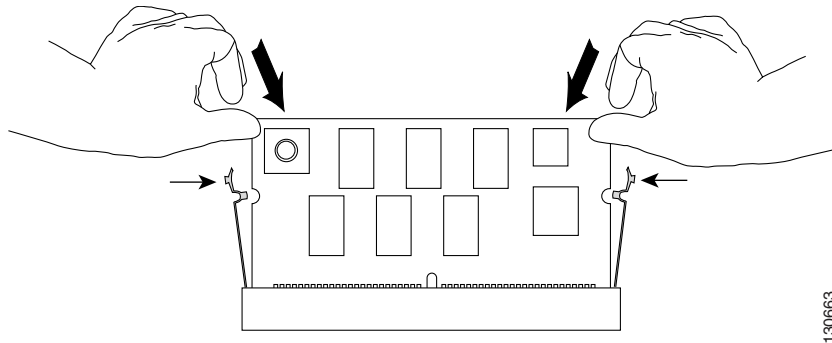
**Figure 4-22** *Seating the Replacement Module*

130661

**Step 9** Make sure the module is fully seated. (See Figure 4-23.)

**Figure 4-23** Correct Module Seating

- Step 10** Push the module toward the back of the chassis and make sure it is clipped in by the levers on both sides. (See Figure 4-24.)

**Figure 4-24** Securing the Module

- Step 11** Repeat Step 4 to Step 10 for the other modules you need to replace.
- Step 12** If you are installing a clock module, secure the module to the backplane using the screws from the earlier removal.
- Step 13** Replace the supervisor engines and switching modules to their previous slots.
- Step 14** Restore power to the switch.

## Verify the New Modules

After the switch is reassembled and power is restored, connect a terminal to the supervisor engine and monitor the boot process. Look for the following messages (or any others), which may indicate a problem with the replaced modules:

```
00:00:20: %C4K_SUPERVISOR-2-MUXBUFFERNOTPRESENT: Mux buffer (WS-X4K-MUX) 3 is not present
00:00:20: %C4K_SUPERVISOR-2-MUXBUFFERNOTPRESENT: Mux buffer (WS-X4K-MUX) 4 is not present
00:00:20: %C4K_SUPERVISOR-2-MUXBUFFERNOTPRESENT: Mux buffer (WS-X4K-MUX) 7 is not present
```

The above messages (either at startup or output from a **show logging** command) indicate that the mux-buffer is not present in slots 3, 4 and 7. You need to reinsert and reseat the modules in those slots.

If the switch has already started up, you may also verify the correct function of the new modules with the **show logging** command.



# Supervisor Memory Upgrade

This section describes how to perform a memory upgrade. You might need to upgrade memory on the Supervisor Engine 6-E for the following reasons:

- To upgrade to a new Cisco IOS feature set or release that requires additional memory. (Memory requirements for each feature set and release are available in the release notes for that release.)
- To use very memory-intensive features.

This document describes how to upgrade dynamic memory. The Supervisor Engine 6-E ships with 512 MB and can be upgraded to 1 GB in the form of an SDRAM miniDIMM.

## Tools and Equipment Needed

You need the following tools and equipment to remove and install miniDIMMs in a Supervisor Engine 6-E:

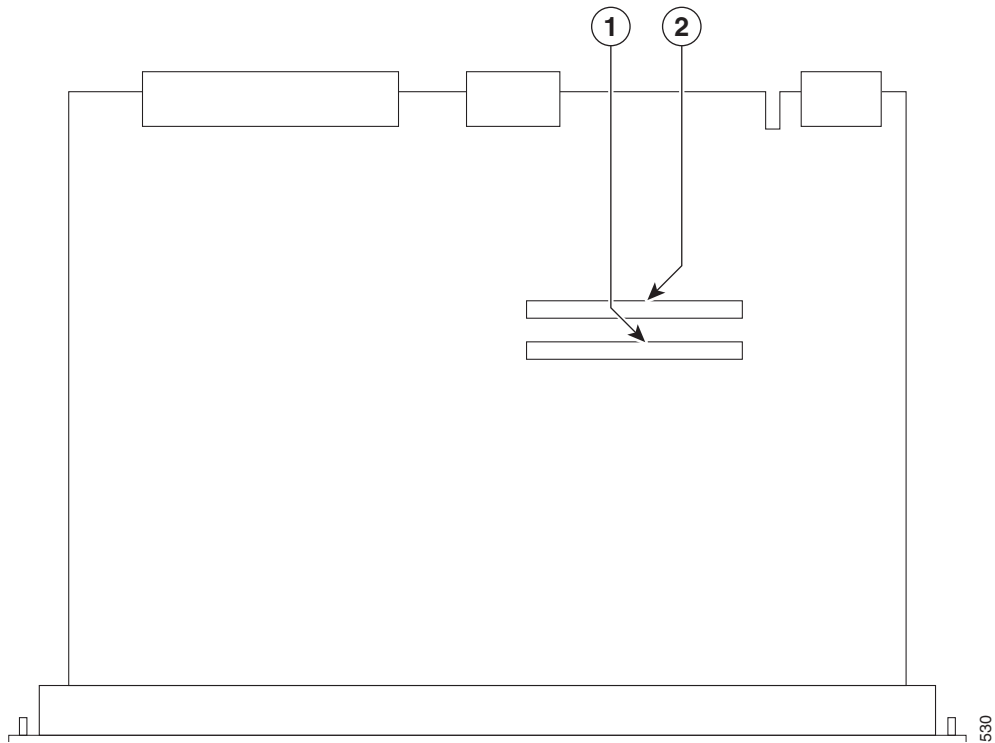
- Number 2 Phillips screwdriver
- Small flat-blade screwdriver
- ESD-preventive wrist strap
- Antistatic mat

## Removing Memory

You will not need to remove the base memory to perform a memory upgrade, but it may make installing the new memory easier. This procedure presumes you have already removed the supervisor engine from the switch. To remove an SDRAM miniDIMM:

- 
- Step 1** Attach an ESD-preventive wrist strap and ensure that it makes good contact with your skin. Connect the equipment end of the wrist strap to the metal back plate of the chassis, avoiding contact with the connectors.
- Step 2** On the mainboard, locate the SDRAM miniDIMM sockets. (See Figure 4-25.)

Figure 4-25 Catalyst 4500 E-Series Supervisor Engine 6-E (WS-Sup-6-E)



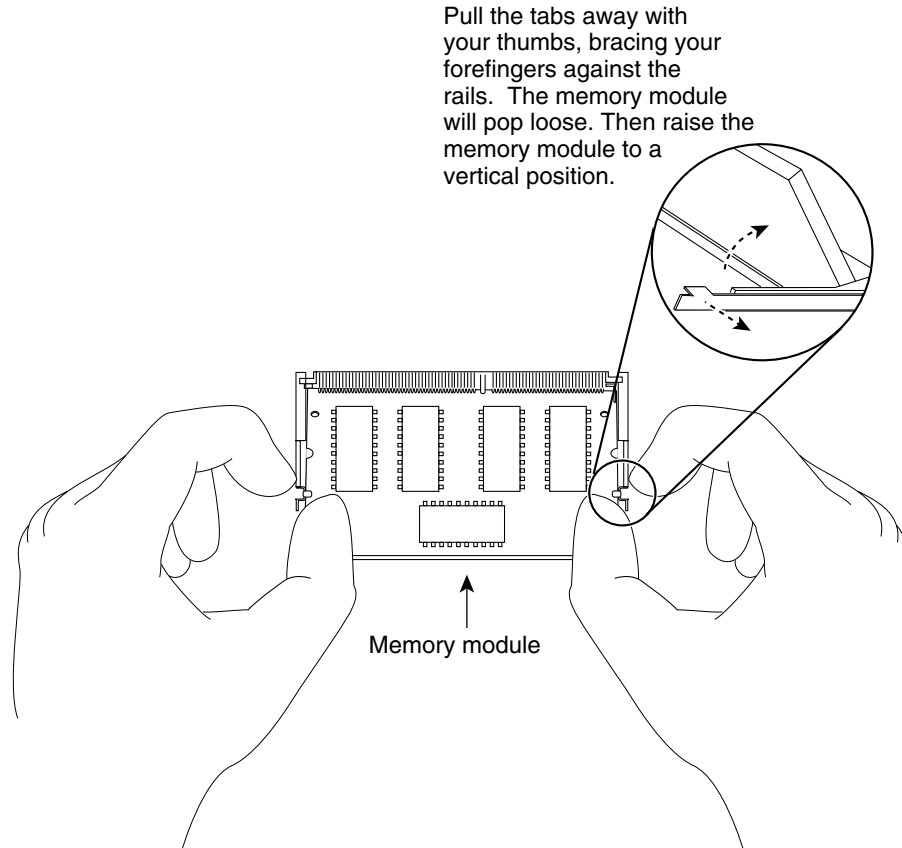
<b>1</b>	Lower slot (u50) Additional memory to be installed in this slot	<b>2</b>	Upper slot (u39) base memory is already installed
----------	--	----------	--

**Caution**

Handle the miniDIMM by the edges only; do not touch the memory modules, pins, or traces (metal fingers along the connector edge). Handle carefully. MiniDIMMs are ESD-sensitive components and can be damaged by mishandling.

**Step 3**

Release the metal clips from the miniDIMM, which releases the miniDIMM from its socket. (See Figure 4-26.)

**Figure 4-26** Removing and Installing SDRAM MiniDIMMs

- Step 4** When both ends of the miniDIMM are released from the socket, grasp the ends of the miniDIMM with your thumb and forefinger and pull it completely out of the socket. Place it in an antistatic bag to protect it from ESD damage.
- Step 5** Proceed to the “Installing SDRAM MiniDIMMs” section on page 4-21.

## Installing SDRAM MiniDIMMs

To install SDRAM MiniDIMMs, follow these steps:

- Step 1** Attach an ESD-preventive wrist strap and ensure that it makes good contact with your skin. Connect the equipment end of the wrist strap to the metal back plate of the chassis, avoiding contact with the connectors.
- Step 2** On the mainboard, locate the SDRAM miniDIMM sockets. (See Figure 4-25.)

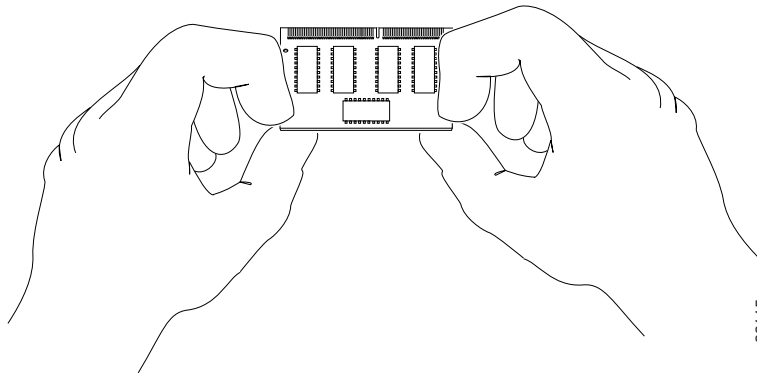


### Caution

Handle the miniDIMM by the edges only; do not touch the memory modules, pins, or traces (metal fingers along the connector edge). Handle carefully. miniDIMMs are ESD-sensitive components and can be damaged by mishandling.

- Step 3** Hold the miniDIMM component-side up, with connector edge (the metal fingers) away from you. Keep the sides of the miniDIMM between your thumb and middle finger, with your forefinger against the far edge and opposite the connector edge. (See Figure 4-27.)

**Figure 4-27** Handling a miniDIMM



- Step 4** Tilt the miniDIMM to the same angle as the socket, then insert the connector edge into the socket. Gently push into place until the metal clips snap into place.



**Caution**

It is normal to feel some resistance when installing a miniDIMM, but do not use excessive force and do not touch the surface components.

- Step 5** Check the two alignment holds and ensure that the metal clips are visible. If necessary, carefully remove and reseat the miniDIMM.
- Step 6** If you are upgrading memory from 512 Mb to 1 Gb and you have removed the miniDIMM in u39, replace it as in steps 3-5.
- Step 7** Replace the supervisor engine in the switch.



# CHAPTER 5

## Troubleshooting

---

If your system has problems during start up or operation, use the information in this chapter to help isolate the cause. Problems with the initial startup are often caused by a switching module that has become dislodged from the backplane or a power cord that is disconnected from the power supply.

Although temperature conditions above the maximum acceptable level rarely occur at initial startup, some environmental monitoring functions are included in this chapter because they also monitor power supply output voltages.

Information about troubleshooting software features and configuration problems is not discussed in this chapter.

More up to date information can be found in the release notes or Error Message Decoder tool. Information specific to your software release can be found in the software configuration guide for that release, or in the system message guide for your release. The following links may be useful in combination with this chapter:

- Release notes

[http://www.cisco.com/en/US/products/hw/switches/ps4324/prod\\_release\\_notes\\_list.html](http://www.cisco.com/en/US/products/hw/switches/ps4324/prod_release_notes_list.html)

- Error Message Decoder

<http://www.cisco.com/cgi-bin/Support/Errordecoder/index.cgi>

- Software configuration guide

[http://www.cisco.com/en/US/products/hw/switches/ps4324/products\\_installation\\_and\\_configuration\\_guides\\_list.html](http://www.cisco.com/en/US/products/hw/switches/ps4324/products_installation_and_configuration_guides_list.html)

- System message guide

[http://www.cisco.com/en/US/products/hw/switches/ps4324/products\\_system\\_message\\_guides\\_list.html](http://www.cisco.com/en/US/products/hw/switches/ps4324/products_system_message_guides_list.html)

This chapter presented in the following sections:

- System Boot Verification, page 5-2
- Using LEDs to Identify Startup Problems, page 5-2
- System Messages, page 5-4
- Troubleshooting with Software, page 5-4
- Troubleshooting the Power Supply, page 5-4
- Troubleshooting the Fan Assembly, page 5-6

- Troubleshooting Backplane Modules, page 5-7
- Troubleshooting Switching Modules, page 5-8
- Troubleshooting Supervisor Engines, page 5-10
- Some Problems and Solutions, page 5-14

**Note**

This chapter covers only the chassis component hardware aspects of troubleshooting. For software configuration issues, refer to the software configuration guide

[http://www.cisco.com/en/US/products/hw/switches/ps4324/products\\_installation\\_and\\_configuration\\_guides\\_list.html](http://www.cisco.com/en/US/products/hw/switches/ps4324/products_installation_and_configuration_guides_list.html)

or command reference

[http://www.cisco.com/en/US/products/hw/switches/ps4324/prod\\_command\\_reference\\_list.html](http://www.cisco.com/en/US/products/hw/switches/ps4324/prod_command_reference_list.html)

for your software release.

## System Boot Verification

When the initial system boot is complete, verify the following:

- That the system software boots successfully
  - Hook up a terminal and view the startup banner. Use an RJ-45-to-RJ-45 rollover cable to connect the console port to a PC with terminal emulation software set for 9600 baud, 8 data bits, no parity, and 1 stop bit. Watch for any system messages after startup.
- That the power supplies are supplying power to the system
  - The power supply's LEDs should be green. Use the **show environment** Cisco IOS command to view power supply activity.
- That the system fan assembly is operating
  - Listen for fan activity. The Fan tray LED should be green during operation. Use the **show environment** Cisco IOS command to view fan tray activity.
- That the supervisor engine and all switching modules are installed properly in their slots, and that each initialized without problems

If all of these conditions are met and the hardware installation is complete, refer to the software configuration guide and command reference publications for your switch so that you can troubleshoot the software.

If any of these conditions is not met, use the procedures in this chapter to isolate and, if possible, resolve the problem.

## Using LEDs to Identify Startup Problems

The key to success when troubleshooting the system is to isolate the problem to a specific system component. Your first step is to compare what the system *is doing* to what it *should be doing*. All system states in the startup sequence are indicated by LEDs. By checking the LEDs, you can determine when

and where the system failed in the startup sequence. If you have problems after the switch is on, refer to the following subsystem troubleshooting information and the configuration procedures in the software configuration guide for your switch.

After you connect the power cords to your Catalyst 4500 series switch, follow these steps to determine whether your system is operating properly:

---

**Step 1** Check the power supply LEDs:

- The LED labeled GOOD should turn green when power is applied to the supply. The LED should remain on during normal system operation.
- If the LED labeled GOOD does not light, or if the LED labeled FAIL lights, see the “Troubleshooting the Power Supply” section on page 5-4.



---

**Note** If a power supply is installed and not connected to a power source, power supply LEDs indicate a failure.

---

**Step 2** Listen for the system fan assembly. The system fan assembly should be operating whenever system power is on. If you do not hear it when the switch is on, see the “Troubleshooting the Fan Assembly” section on page 5-6.

**Step 3** Check that the LEDs on the supervisor engine light as follows:

- The LED labeled STATUS flashes orange once and stays orange during diagnostic boot tests.
    - It turns green when the module is operational (online).
    - If the system software is unable to start up, this LED stays orange.
    - If the LED labeled STATUS on the supervisor engine front panel is red or orange, connect a console to the management port and use the **show environment** command to check for possible problems.
  - The Ethernet management port LED turns green when the module is operational (online) and a link is established with another network device. If no signal is detected, the LED labeled LINK turns off.
- If there is a problem with the supervisor engine, try reseating the supervisor engine in the chassis and restarting the switch. For more information about LED meanings, refer to the “LEDs” section on page 1-22. For more troubleshooting information, see the “Troubleshooting Supervisor Engines” section on page 5-10.

**Step 4** Verify that the LEDs labeled STATUS on each switching module are green when the supervisor engine completes initialization.

This LED indicates that the supervisor engine and switching modules are receiving power, have been recognized by the supervisor engine, and contain a valid Flash code version. However, this LED does not indicate the state of the individual interfaces on the switching modules. If an LED labeled STATUS is red or orange, try reseating the switching module or supervisor engine and restarting the switch. For more information, see the “Troubleshooting Switching Modules” section on page 5-8. If you determine that the switching module is not operating, contact Cisco TAC as described in the “Some Problems and Solutions” section on page 5-14.

**Step 5** If the boot information and system banner are not displayed, verify that the terminal is set for 9600 baud, 8 data bits, no parity, and 1 stop bit and connected properly to the console port.

---

## System Messages

System messages appear on the console if you have enabled console logging or appear in the syslog if you have enabled syslog. Many messages are for informational purposes only and do not indicate an error condition. Enter the **show logging** command to display the log messages. To better understand a specific system message, refer to the system message guide for your software release. Most messages are also documented in the Error Message Decoder tool at:

<http://www.cisco.com/cgi-bin/Support/Errordecoder/index.cgi>

System messages specific to the system components are mentioned in the corresponding sections that follow. If you see one of these messages, use the Decoder tool and follow the suggestion provided there.

## Troubleshooting with Software

Many problems can be identified with CLI commands, and following sections will mention them as appropriate.

Certain problems can be due to not having the right software to support your hardware. For the most recent software release to get the current recommended version for a particular system component, please refer to the release notes at

[http://www.cisco.com/en/US/products/hw/switches/ps4324/prod\\_release\\_notes\\_list.html](http://www.cisco.com/en/US/products/hw/switches/ps4324/prod_release_notes_list.html)

## Troubleshooting the Power Supply

To help isolate a power subsystem problem, follow these steps:

- 
- Step 1** Check whether the power supply LED labeled GOOD is on or the LED labeled FAIL is on. (on the DC multi-input power supply, the LEDs are labeled INPUT 1, 2, or 3 or OUTPUT FAIL.)
- Step 2** If the LED labeled GOOD is off or if the LED labeled FAIL is on, take the following steps:
- Ensure that the power supply is flush with the back of the chassis.
  - Unplug the power cord, loosen and reinstall the power supply, tighten the captive installation screws, and then plug in the power cord.
- Step 3** If the LED labeled GOOD remains off, there might be a problem with the AC source or the power cable. Connect the power cord to another power source if one is available. Verify that the source power is acceptable within the specifications of the power supply.
- Step 4** If the LED labeled GOOD fails to light after you connect the power supply to a new power source, replace the power cord.




---

**Note** If this unit has more than one power cord, repeat Step 1 through Step 4 for each power input.

---

- Step 5** If the LED labeled GOOD still fails to light when the switch is connected to a different power source with a new power cord, the power supply is probably faulty. See the “System Messages and Power Problems” section on page 5-5. You may need to replace the power supply.



- Step 6** If the LED labeled FAN OK fails to light when the switch is connected to a good power source with a known good power cord, there is a malfunction in the fan that cools the power supply. Replace the power supply.
- Step 7** If a second power supply is available, install it in the second power supply bay.
- Step 8** Check that the LED labeled GOOD is on for the additional power supply. Check that the LED labeled FAIL is off.
- Step 9** If the LEDs are not on, repeat the previous procedure to troubleshoot the second power supply. If you are unable to resolve the problem, or if you determine that either a power supply or backplane connector is faulty, contact Cisco Technical support for instructions.
- 

## System Messages and Power Problems

Check for system messages related to the power supply, and refer to the system message guide for your software release. You may need to add a power supply or upgrade to a larger one for your current configuration or verify that the switches are set properly on the power supply. Connect a terminal to the console port, and look for any of the following system messages (there may be others, depending on the software release):

```
C4K_CHASSIS-2-INLINEPOWEROFF
C4K_IOSMODPORTMAN-4-INLINEPOWERSUPPLYBAD
C4K_IOSMODPORTMAN-4-INLINEPOWEROVERMAX
C4K_CHASSIS-2-INSUFFICIENTPOWERDETECTED
C4K_CHASSIS-2-INSUFFICIENTPOWERSHUTDOWN
C4K_CHASSIS-3-INSUFFICIENTPOWER
C4K_CHASSIS-3-INSUFFICIENTPOWERSUPPLIESDETECTED
C4K_CHASSIS-3-MIXINPOWERDETECTED
C4K_IOSMODPORTMAN-3-UNKNOWNPOWERSUPPLY
C4K_IOSMODPORTMAN-4-POWERSUPPLYBAD
C4K_IOSMODPORTMAN-4-POWERSUPPLYFANBAD
C4K_SUPERVISOR-3-POWERSUPPLYSTATUSREADFAILED
C4K_SUPERVISOR-3-POWERSUPPLYSEEPROMREADFAILED
C4K_SUPERVISOR-3-POWERSUPPLYSEEPROMINVALID
```

If you see any of these messages or other messages, go to the following location and enter the message text to find recommendations for your situation.

<http://www.cisco.com/cgi-bin/Support/Errordecoder/index.cgi>

## Useful CLI Commands

You may also use the **show environment status powersupply**, **show module all**, and **show power** commands to monitor PS status, load, and activity.

If the **show module** command output shows a message that states "not enough power for module," check the "Catalyst 4500 Power Supplies" section on page A-6 for the minimum power requirements for the power supply. There may be a problem with the power source itself.

## Power Supply Mixing

The 1400 W DC multi-input supply can not be used with other power supply types, but other power supplies in this product line work with the other types during an upgrade. If you mix power supplies in a Catalyst 4500 series chassis, the switch detects the type of power supply in power supply bay 1 (PS1) and ignores the power supply in power supply bay 2 (PS2) while issuing system messages and showing the power supply in bay 2 as in the err-disable state in the output of the **show power** command. When the power supply in bay 1 is removed, the switch recognizes the power supply in bay 2, and you may then put a new matching power supply in bay 1. Both supplies should resume normal function.

## Troubleshooting the Fan Assembly




---

**Note** All fans must be operating or a failure will occur.

---

Environmental problems may initially appear to be problems with the fan tray. To help isolate a fan assembly problem, follow these steps:

---

- Step 1** Check the status LED on the fan tray.
- If the LED is off and the rest of the system is functioning, the fan tray is not getting power or is not seated correctly on the backplane.
  - If the LED is green, the fans are operating normally. There may be conditions impairing fan performance, but they are minimal in impact.
  - If the LED is red, one or more fans have failed.
- Step 2** Connect a terminal and determine the fan tray status shown by the **show environment status** CLI command. The status and sensor columns should say *good*.
- Step 3** Determine whether the airflow is restricted or if the ambient temperature in the room is too warm.
- Step 4** Determine whether the power supply is functioning properly. See the "Troubleshooting the Power Supply" section on page 5-4.
- Step 5** Verify that the fan assembly is properly seated in the backplane by loosening the captive installation screws, removing the fan assembly, and reinstalling it.
- Step 6** Restart the system.
- Step 7** Verify that all fans are operating. You should hear the fans at system start.
- Step 8** If the system is still detecting a fan assembly failure, check for details using the CLI and contact the Cisco TAC for assistance.
-

## System Messages and Fan Problems

Look for system messages reporting a temperature problem or problem with the fans. Individual messages may suggest different solutions. Connect a terminal to the console port, and look for any of the following system messages:

```
C4K_CHASSIS-2-INSUFFICIENTFANSDETECTED
C4K_CHASSIS-2-INSUFFICIENTFANSSHUTDOWN
C4K_IOSMODPORTMAN-4-CRITICALTEMP
C4K_IOSMODPORTMAN-4-FANTRAYBAD
C4K_IOSMODPORTMAN-4-FANTRAYPARTIALFAILURE
C4K_IOSMODPORTMAN-4-FANTRAYREMOVED
C4K_SUPERVISOR-3-FANTRAYREADFAILED
C4K_SUPERVISOR-3-FANTRAYSEEPROMREADFAILED
C4K_SUPERVISOR-3-FANTRAYSEEPROMINVALID
C4K_IOSMODPORTMAN-4-TEMPHIGH
C4K_IOSMODPORTMAN-4-TEMPUNDERCRITICAL
C4K_CHASSIS-2-OVERHEATINGSHUTDOWN
```

If you see any of these messages or other messages related to fans, go to the following location and enter the message text to find recommendations for your situation.

<http://www.cisco.com/cgi-bin/Support/Errordecoder/index.cgi>

## Useful CLI Commands

The **show environment status fantray** command can give additional information useful in diagnosing fan tray problems.

## Troubleshooting Backplane Modules

The Cisco Catalyst 4500 E-series redundancy scheme uses removable redundancy modules (also called mux-buffers), on the passive backplane to switch traffic to the active supervisor engine. There is one redundancy module per switching module. Redundancy modules and a redundant clock ship standard with every Cisco Catalyst 4507R-E and 4510R-E chassis. Spare redundancy modules (**WS-X4590-E=**) and a clock module (**WS-X4K-CLOCK-E=**) are available for serviceability.

The following conditions indicate that you may need to replace the redundancy modules and clock module:

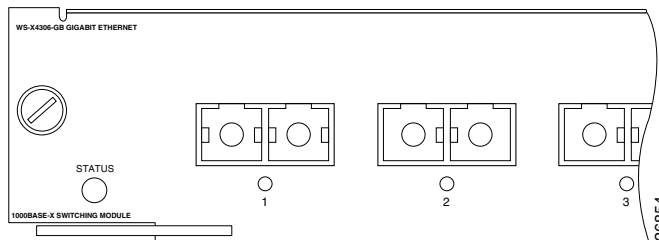
- The switch powers down and stays down for a few minutes to a few days for no clear reason.
- The output-fail LED on the power supplies are red and no power is delivered to the chassis. The other LEDs on the power supply are green.
- The Status LEDs on the switching modules and the supervisor engine are flashing green.
- CPU Utilization LEDs are flashing green or off.

If you observe these conditions, contact the Cisco TAC for assistance in ordering replacement redundancy modules and a clock.

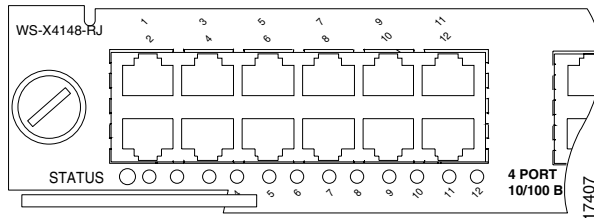
## Troubleshooting Switching Modules

Each switching module has one LED labeled STATUS that provides information about the module and one numbered LED labeled LINK for each port on the module. Figure 5-1 shows the Gigabit Ethernet port and status LEDs. Figure 5-2 shows the 10/100BASE-T port LEDs. Table 5-1 describes the switching module LEDs and their expected behavior.

**Figure 5-1** Gigabit Ethernet Port and Status LEDs



**Figure 5-2** 10/100BASE-T Port LEDs



**Table 5-1** Switching Module LEDs

LED	Color/State	Description
STATUS	Green	All the tests pass.
	Red	A test other than an individual port test failed.
	Orange	System boot, self-test diagnostics running, or the module is disabled.
LINK	Green	The port is operational (a signal is detected).
	Orange	The link has been disabled by software.
	Flashing orange	The link has been disabled due to a hardware failure.
	Off	No signal is detected.

**Table 5-1 Switching Module LEDs (continued)**

LED	Color/State	Description
Port Status <sup>1</sup>		Indicates individual port status.
	Green	The port is operational (a signal is detected).
	Orange	The link has been disabled by software.
	Flashing orange	The link has been disabled due to a hardware failure.
	Off	No signal is detected.

1. LEDs labeled 1 through the number of ports on the switching module are the individual port link LEDs.

## System Messages and Switching Modules

Connect a terminal to the console port, and look for any of the following system messages:

C4K\_CHASSIS-3-LINECARDMUXBUFFERTOSUPALIGNMENTWRONG

C4K\_CHASSIS-3-LINECARDNOTVALIDINSLOT

C4K\_CHASSIS-3-MODULENOTSUPPORTHALF

C4K\_IOSINTF-5-STALEPHYPORT

C4K\_IOSMODPORTMAN-4-INLINEPOWEROVERMAX

If you see any of these messages or other messages, go to the following location and enter the message text to find recommendations for your situation.

<http://www.cisco.com/cgi-bin/Support/Errordecoder/index.cgi>

## Useful CLI Commands

Some problems can be solved by resetting the switching module. Use the **hw-module module <n> reset** command to reset a switching module, or remove and re-insert the switching module, which resets, restarts, and power cycles the switching module. The **show module** and **show diagnostics online module** commands can also provide information useful in solving problems with ports on individual modules.

Not all software versions support all switching modules. If you are having trouble with a module, refer to the software release notes to be sure that it is supported by your software.

# Troubleshooting Supervisor Engines

This section only addresses problems with hardware. Problems with features or configuration are not covered here. Refer for your software configuration guide and release notes for information on configuring features or identifying known problems.

Table 5-2 describes the supervisor engine LEDs. Check the LEDs on your supervisor and compare them to the described LED behaviors.

**Table 5-2 Supervisor Engine LEDs**

LED	Color/State	Description
STATUS	Green	Indicates the results of a series of self-tests. All diagnostic tests passed.
	Red	A test failed.
	Orange	System boot or diagnostic test is in progress.
	Off	Module is disabled.
UTILIZATION	Green 1–100%	If the switch is operational, this display indicates the current traffic load over the backplane (as an approximate percentage).
LINK	Green	Indicates the status of the 10/100BASE-T Ethernet management port or uplink ports. The link is operational.
	Orange	The link is disabled by user.
	Flashing orange	The power-on self-test indicates a faulty port.
	Off	No signal is detected or there is a link configuration failure.
ACTIVE	Green	Indicates whether the uplink port is active or not. The port is active.
	Off	The port is not active.
ACTIVE		The LED to the right of the uplink ports is used to identify the active supervisor engine in switches with two supervisor engines.

## System Messages and Supervisor Engines

Connect a terminal to the console port, and look for any of the following system messages:

```
C4K_CHASSIS-3-LINECARDMUXBUFFERTOSUPALIGNMENTWRONG
C4K_SUPERVISOR-3-MUXBUFFERREADSUPERVISORSELECTIONFAILED
C4K_CHASSIS-3-TEMPERATURESENSORREADFAILED
C4K_HW-3-X2IDENTIFICATIONFAILURE
```

C4K\_HW-3-X2OUIREGREADFAILURE  
C4K\_HWACLMAN-4-CLASSIFCAMPARITYERROR  
C4K\_HWACLMAN-4-CLASSIFCAMREPLYPARITYERROR  
C4K\_HWACLMAN-4-CLASSIFCAMREQPARITYERROR  
C4K\_HWNETFLOWMAN-3-NETFLOWSTOPPED  
C4K\_HWNETFLOWMAN-4-FATALERRORINTERRUPTSEEN  
C4K\_HWNETFLOWMAN-4-NONFATALPARITYERRORINTERRUPTSEEN  
C4K\_IOSMODPORTMAN-4-NFLABSENT  
C4K\_IOSMODPORTMAN-4-NFLIDPROMINVALID  
C4K\_IOSMODPORTMAN-4-NFLMISMATCH  
C4K\_REDUNDANCY-2-HANDSHAKE\_TIMEOUT  
C4K\_REDUNDANCY-2-POSTFAIL\_RESET  
C4K\_REDUNDANCY-2-INCOMPATIBLE\_SUPERVISORS  
C4K\_REDUNDANCY-2-IOS\_VERSION\_CHECK\_FAIL  
C4K\_REDUNDANCY-2-IOS\_VERSION\_INCOMPATIBLE  
C4K\_REDUNDANCY-2-NON\_SYMMETRICAL\_REDUNDANT\_SYSTEM  
C4K\_REDUNDANCY-2-POSTFAIL  
C4K\_REDUNDANCY-2-POSTFAIL\_RESET  
C4K\_REDUNDANCY-4-CONFIGSYNCFail  
C4K\_SUPERVISOR-2-SUPERVISORSEEPROMINVALID  
C4K\_SUPERVISOR-3-RETIMERDISABLEFAILED  
C4K\_SUPERVISOR-3-RETIMERINITFAILED  
C4K\_SUPERVISOR-3-SEEPROMREADFAILED  
C4K\_SUPERVISOR-4-INLINEVOLTAGEOUTOFRANGE  
C4K\_SUPERVISOR-7-SEEPROMWRITEFAILED  
C4K\_SWITCHMANAGER-3-SSOACTIVEPORTACKTIMEOUT  
C4K\_SYSMAN-2-POWERONSELFTESTFAIL

These system messages indicate a problem with the supervisor engine. Some problems will prevent a console connection and will not allow you to use messages in diagnosing a problem. If you are unable to establish a terminal connection and the STATUS LED is red, contact Cisco TAC immediately to order a replacement.

Problems with redundant supervisor systems are often due to mismatched active and standby supervisor engines. Redundancy requires that both supervisor engines be the same model, have the same amount of SDRAM memory and running the same Cisco IOS release. If one supervisor has a NetFlow service card, the other must as well.

Some problems with supervisor engines are due to backplane connections that are not fully seated. If removing and reinserting the supervisor engine and then restarting the switch does not solve the problem, you may need to call Cisco TAC and replace the supervisor engine.

## Useful CLI Commands

Some problems can be solved by resetting the supervisor engine. Use the **hw-module module <n> reset power-cycle** command to reset a switching module, or remove and re-insert the switching module, which resets, restarts and power cycles the switching module. Pressing the reset button on the supervisor engine causes the software to reload, but does not power cycle the supervisor engine.



### Note

When you power-cycle or remove a supervisor engine in a redundant system the other supervisor engine becomes the active supervisor and the ports retain connectivity. In a non-redundant system, all of the switching modules lose connectivity until the supervisor engine is reinserted and completely restarted.

The **show diagnostics power-on** command may provide useful information for some supervisor engine problems.

Not all software versions support all supervisor engines. If you are having trouble with a supervisor engine, refer to the software release notes to be sure that it is supported by your software.

## Standby Supervisor Engine Problems

If the standby supervisor engine module is not online or status indicates “other” or “faulty” in the output of the **show module** command or an amber status LED, create a console connection to the standby supervisor engine and verify that it is in ROMmon mode or in continuous reboot. If the standby supervisor engine is in either of these two states, refer to:

[http://www.cisco.com/en/US/products/hw/switches/ps663/products\\_configuration\\_example09186a0080094ecf.shtml](http://www.cisco.com/en/US/products/hw/switches/ps663/products_configuration_example09186a0080094ecf.shtml)

```
switch# show module
```

Mod	Ports	Card Type	Model	Serial No.
1	2	1000BaseX (GBIC) Supervisor(active)	WS-X4515	JAB0627065V
2		<b>Standby Supervisor</b>		
3	48	10/100/1000BaseTX (RJ45)	WS-X4448-GB-RJ45	JAB053606AG
4	48	10/100BaseTX (RJ45)V	WS-X4148-RJ45V	JAE060800BL

M	MAC addresses	Hw	Fw	Sw	Status
1	0009.e845.6300 to 0009.e845.6301	0.4	12.1(12r)EW	12.1(12c)EW, EAR	Ok
2	<b>Unknown</b>	<b>Unknown</b>	<b>Unknown</b>	<b>Unknown</b>	<b>Other</b>
3	0001.6443.dd20 to 0001.6443.dd4f	0.0			Ok
4	0008.2138.d900 to 0008.2138.d92f	1.6			Ok

Make sure that the supervisor engine module properly seats in the backplane connector and that you have completely screwed down the captive screws for the supervisor engine.

In order to determine whether the standby supervisor engine is faulty, enter the **redundancy reload peer** command from the active supervisor engine and through the console to the standby supervisor engine. Observe the bootup sequence in order to identify any hardware failures. Currently, the active supervisor engine cannot access the power-on diagnostics results of the standby supervisor engine.

Make sure that these configurations are synchronized between the active and redundant supervisor engines:

- Startup configuration
- Boot variable



- Configuration register
- Calendar
- VLAN database

If a software upgrade is performed on both the active and standby supervisor engines, verify that both supervisor engines are running the same new software image. If the software images are not the same, upgrade the software image. Use the procedure in the software configuration guide for your release.

If the standby supervisor engine still does not come on line, create a service request with Cisco Technical Support. Use the log of the switch output that you collected from the previous troubleshooting steps.

## Switch Self-reset

If the switch has reset or rebooted on its own, verify that the power source for the switch did not fail. If you use an uninterruptible power supply (UPS), make sure that the UPS does not have any problems.

The switch might have had a software crash. Enter the **more crashinfo:data** command to display the crash information including date and time of the last time that the switch crashed. To display the standby supervisor engine crash data, enter the **more slavecrashinfo:data** command. The crash data are not present if the switch has never crashed.

```
Switch# more crashinfo:data  
Current time: 04/21/2000 19:58:10
```

```
Last crash: 04/21/2000 03:58:56
```

```
!--- Output suppressed.
```

If the output indicates a software crash at the time that you suspect that the switch rebooted, the problem can be something other than a hardware failure. Contact Cisco Technical Support with the output of these commands:

- **show tech-support**
- **show logging**
- **more crashinfo:data**

If you are still unable to determine the problem, contact Cisco Technical Support.

## Ports 1/2 and 2/2 Do Not Function

If you have dual supervisor engines in a Catalyst 4507R or a Catalyst 4510R chassis and your ports 1/2 and 2/2 do not function, the system is functioning as designed, which is to have two uplinks operational at all times. The dual uplinks must also work when only one supervisor engine is present. This means that if only one supervisor engine is present and is in slot 1, both ports 1/1 and 1/2 are functional. Also, if only one supervisor engine is present and is in slot 2, ports 2/1 and 2/2 are functional. When dual supervisor engines are present, only ports 1/1 and 2/1 are functional and 1/2 and 2/2 are not functional. For more information, refer to the redundancy chapter in the software configuration guide.

## Packet Loss

If your system exhibits partial or full loss of network connectivity or packet loss, perform basic troubleshooting procedures to eliminate the common causes. The common causes include:

- Bad cabling

- A bad port
- Speed and duplex mismatch
- Network interface card (NIC) issues

If you troubleshoot these common reasons and you are not able to narrow down the problem, follow the steps in this section and capture the output of commands at each step, then contact Cisco Technical Support for additional troubleshooting assistance.

- 
- Step 1** Power cycle the switch and observe the POST results at bootup.
- Step 2** Enter the **show diagnostics power-on** command to verify the POST results from bootup and determine if diagnostics fail again. If diagnostics fail again, the problem is most likely hardware. Contact Cisco Technical Support for further assistance. If the supervisor engine passes the diagnostic tests without any failure after the power cycle in Step 4, perform these steps:
- a. Collect the output from the **show tech-support** command.
  - b. Remove all power supplies from the box, and collect the serial numbers, Cisco part number, and manufacturer of the power supplies.
  - c. Contact Cisco Technical Support with the information that you collected.




---

**Note** If Cisco Technical Support did not assist with the troubleshoot procedure, you must provide the information in the order of these steps.

---

## Some Problems and Solutions

### Module Not Online

Part or all of the module can fail to come online. You may have a module failure if you see an amber or red status LED or if you see one of these statuses in the output of the **show module** command:

- other
- faulty
- err-disable
- power-deny
- power-bad

Make sure that the module is properly seated and that you have completely screwed down the module. If the module still does not come online, enter the **hw-module slot slot number reset** command. If the module still does not come online, try the module in a spare slot, swap the module with the slot of a module that works, or try the module in a different chassis.

If the status is “power-deny,” the switch does not have enough power available to power this module. Enter the **show power** command in order to confirm whether enough power is available. For more information, refer to the “Environmental Monitoring and Power Management” chapter in the software configuration guide for your software release.

If the status is “power-bad,” the switch detects a switching module but is unable to allocate power. This situation is possible if the supervisor engine cannot access the serial PROM (SPROM) contents on the module in order to determine the identification of the line card. Enter the **show idprom module slot** command to verify that the SPROM is readable. If the SPROM is not accessible, reset the module.

Enter the **show diagnostics online module slot number** command to identify hardware failures on the module. If the module still does not come online, create a service request with Cisco Technical Support in order to troubleshoot further. Use the log of the switch output that you collected in the above output and the troubleshooting steps that you performed.

## Interface Problems

If you see an error mentioned in the output of the **show interface** command, the reason could be:

- A physical layer problem, such as a faulty cable or NIC
- A configuration problem, such as a speed and duplex mismatch
- A performance problem, such as an oversubscription

In order to understand and troubleshoot these problems, refer to *Troubleshooting Switch Port and Interface Problems* at:

[http://www.cisco.com/en/US/products/hw/switches/ps700/products\\_tech\\_note09186a008015bfd6.shtml](http://www.cisco.com/en/US/products/hw/switches/ps700/products_tech_note09186a008015bfd6.shtml)

## Workstation Is Unable to Log In to the Network

If you observe that a workstation is unable to log into the network during startup or unable to obtain the DHCP address when you have powered up a client machine or rebooted, an initial connectivity delay that the switch introduced could be the problem. To verify this, check the following:

- Microsoft network client displays "No Domain Controllers Available".
- DHCP reports "No DHCP Servers Available."
- A Novell Internetwork Packet Exchange (IPX) network workstation does not have the Novell login screen upon bootup.
- An AppleTalk network client displays, "Access to your AppleTalk network has been interrupted. In order to reestablish your connection, open and close the AppleTalk control panel." The AppleTalk client chooser application can either fail to display a zone list or display an incomplete zone list.
- IBM Network stations can have one of these messages:
  - NSB83619—Address resolution failed
  - NSB83589—Failed to boot after 1 attempt
  - NSB70519—Failed to connect to a server

The reason for these symptoms can be an interface delay that either Spanning Tree Protocol (STP), EtherChannel, trunking, or an autonegotiation delay causes. For more information about these delays and possible solutions, refer to

:

[http://www.cisco.com/en/US/products/hw/switches/ps700/products\\_tech\\_note09186a00800b1500.shtml](http://www.cisco.com/en/US/products/hw/switches/ps700/products_tech_note09186a00800b1500.shtml)

If you review and follow the procedure in the document and you still have issues, contact Cisco Technical Support.

## NIC Compatibility Issues

You can have NIC compatibility or misconfiguration issues with the switch if you experience one of these symptoms:

- A server or client connection to the switch does not come up
- Autonegotiation issues
- Errors on the port

The reason for these symptoms can be a known NIC driver issue, speed and duplex mismatch, or autonegotiation or cabling problems. For more troubleshooting information, refer to:

[http://www.cisco.com/en/US/products/hw/switches/ps700/products\\_tech\\_note09186a00800a7af0.shtml](http://www.cisco.com/en/US/products/hw/switches/ps700/products_tech_note09186a00800a7af0.shtml)

If you still have issues after you review and follow the procedure in the document *Troubleshooting Cisco Catalyst Switches to NIC Compatibility Issues*, contact Cisco Technical Support for further assistance.

## Interface Is in Errdisable

If the interface status is err-disable in the output of the **show interface status** command, some possible reasons include:

- Duplex mismatch
- Port channel misconfiguration
- Bridge protocol data unit (BPDU) guard violation
- UniDirectional Link Detection (UDLD) condition
- Late-collision detection
- Link-flap detection
- Security violation
- Port Aggregation Protocol (PAgP) flap
- Layer Two Tunneling Protocol (L2TP) guard
- DHCP snooping rate-limit

In order to troubleshoot these scenarios, refer to the specific feature information in the *Catalyst 4500 Series Switch Cisco IOS Software Configuration Guide* for your software release.

## Faulty Supervisor Engine

If the supervisor engine STATUS LED is red, establish a console connection to the supervisor engine and enter the **show diagnostics power-on** command, if you can. If you are unable to get a console connection or the command output indicates a failure, contact Cisco Technical Support.

If the switch does not boot and fails self diagnostics during the boot sequence, capture the console output of the startup sequence then contact Cisco Technical Support.

If you do not see any hardware failure in the boot sequence or in the output of the **show diagnostics power-on** command, contact Cisco Technical Support.

## Boot Problems

If the switch is in a continuous boot loop, is in ROMmon mode, or does not have a system image, there is mostly likely not a hardware problem. The supervisor engine operates in a continuous loop if you have not set the boot variable correctly and you have set the configuration register to 0x2102. For instructions on how to recover the supervisor engine, refer to the “Recovering from a Continuous Reboot” section of the document at this location:

[http://www.cisco.com/en/US/products/hw/switches/ps663/products\\_configuration\\_example09186a0080094ecf.shtml](http://www.cisco.com/en/US/products/hw/switches/ps663/products_configuration_example09186a0080094ecf.shtml)

The supervisor engine goes into ROMmon mode or fails to boot when the system image is either corrupt or absent. For instructions on how to recover the supervisor engine, refer to the “Recovering from a Corrupt or Missing Image” section of the document at this location:

[http://www.cisco.com/en/US/products/hw/switches/ps663/products\\_configuration\\_example09186a0080094ecf.shtml](http://www.cisco.com/en/US/products/hw/switches/ps663/products_configuration_example09186a0080094ecf.shtml)

The supervisor engines have onboard system Flash memory (bootflash), which should easily hold multiple system images. Therefore, have a backup image. In addition to the bootflash, the supervisor engine supports up to 128 MB of compact Flash in the slot0: device. The supervisor engine also provides for transfer via TFTP of the image from ROMmon mode, which enables faster recovery of absent or corrupt images.

## Cannot Connect to a Switch Through the Console Port

Make sure you are using the correct type of cable. Make sure the terminal configuration matches the switch console port configuration—default console port settings are 9600 baud, 8 data bits, no parity, 1 stop bit. Make sure the cable pinouts are correct for your supervisor engine (refer to the hardware documentation for your supervisor engine).

## Cannot communicate with another device, Cannot Telnet to the switch, Cannot communicate with a local or remote host

Follow these steps:

- 
- Step 1** Make sure the LINK LED for the port is green.
  - Step 2** Check the cabling:
    - Host-to-switch 10BASET connections and router-to-switch 10BASET or 100BASETX connections typically are made using a straight-through cable.
    - Switch-to-switch connections typically are made using a rollover cable.
    - For SC- or ST-type fiber connections, make sure transmit (Tx) on one end of the link connects to receive (Rx) on the other end of the link.
  - Step 3** Make sure the interface you are connecting to (sc0 or me1) is configured UP (use the **show interface** command to check).
  - Step 4** Make sure the IP address, subnet mask, and VLAN membership of the switch interface (sc0 or me1) is correct (use the **show interface** command).
  - Step 5** To prevent conflicts, make sure the me1 and sc0 interfaces are configured with IP addresses and subnet masks in different subnets (use the **show interface** command to check), or disable one of the interfaces using the **set interface {sc0 | me1} disable** command.
  - Step 6** Make sure the host configuration (IP address, subnet mask, default gateway, speed, and duplex setting) is correct.

- Step 7** If you cannot connect to the switch through the me1 interface, make sure the connected device is configured for half-duplex 10-Mbps operation.
- Step 8** If the host is in the same subnet as the switch interface, make sure the switch interface and the switch port to which the host is connected are assigned to the same VLAN (use the **show interface** and **show port** commands to check).
- Step 9** If the host is in a different subnet, make sure the default gateway (default route) on the switch is configured with the address of a router in the same subnet as the switch interface (use the **show ip route** command).
- Step 10** Check the status of the port connection—should be “connected” (use the **show port** command).
- Step 11** Check the spanning-tree state on the port (use the **show spantree mod\_num/port\_num** command)—if the port is in listening or learning mode, wait until the port is in forwarding mode and try to connect to the host again.
- Step 12** Make sure the speed and duplex settings on the host and the appropriate switch ports are correct (use the **show port** command).
- Step 13** If the connected device is an end station:
- a. Enable spanning-tree PortFast on the port (use the **set spantree portfast enable** command)—PortFast places the port in forwarding mode immediately, bypassing listening and learning modes (do *not* use this feature for connections to non-end station devices).
  - b. Disable trunking on the port (use the **set trunk mod\_num/port\_num off** command).
  - c. Disable channeling on the port (use the **set port channel port\_list off** command)—you must specify a valid port range with this command—you cannot specify a single port.
- Step 14** Make sure the switch is learning the MAC address of the host (use the **show cam dynamic** command).
- Step 15** If possible, try connecting to another port.
- 

### Cannot autonegotiate the port speed/duplex

Make sure autonegotiation is configured on both ends of the link (use the **show port** command)—you cannot configure settings manually on one end of the link and configure the other end of the link for autonegotiation. If autonegotiation fails when you connect a client NIC to the switch, check the NIC and drivers to make sure that autonegotiation is supported.

If autonegotiation is supported and properly configured but you still cannot connect, turn off autonegotiation and set the speed and duplex manually (use the **set port speed** and **set port duplex** commands).

## Contacting the Cisco Technical Assistance Center

If you are unable to solve a startup problem after using the troubleshooting suggestions in this chapter, contact a Cisco TAC representative for assistance and further instructions.

Before you call, have the following information ready to help the Cisco TAC assist you as quickly as possible:

- Date you received the switch
- Chassis serial number (refer to Figure 5-3 for serial number locations)
- Type of software and release number

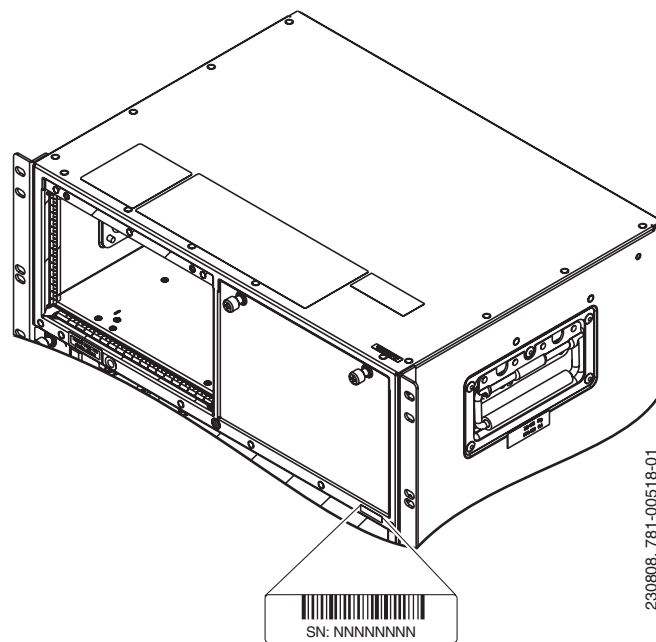
- Maintenance agreement or warranty information
- Brief description of the problem
- Console captures related to your problem
- Brief explanation of the steps you have already taken to isolate and resolve the problem

See the “Obtaining Documentation and Submitting a Service Request” section on page xv for more information about contacting the TAC.

## Serial Numbers

When you contact TAC, have the serial number of your switch available. Refer to Figure 5-3 to locate the serial number on your switch. You may also get the serial number from the output of a **show version** or **show idprom all** command.

**Figure 5-3** Catalyst 4500 E-series Serial Number Location









# APPENDIX **A**

## Specifications

---

Cable and technical specifications for Catalyst 4500 E-series switches are provided in the following sections:

- Catalyst 4503-E Switch Specifications, page A-1
- Catalyst 4506-E Switch Specifications, page A-2
- Catalyst 4507R-E Switch Specifications, page A-3
- Catalyst 4510R-E Switch Specifications, page A-5
- Catalyst 4500 Power Supplies, page A-6



**Note**

Specifications for individual switching modules and supervisor engines, including power consumption and thermal output information, are in the *Catalyst 4500 Series Module Installation Guide*, available online at:

[http://www.cisco.com/en/US/docs/switches/lan/catalyst4500/hardware/module/guide/mod\\_inst.html](http://www.cisco.com/en/US/docs/switches/lan/catalyst4500/hardware/module/guide/mod_inst.html)

---

## Catalyst 4503-E Switch Specifications

Table A-1 lists the Catalyst 4503-E switch specifications.

**Table A-1**      **Catalyst 4503-E Switch Specifications**

Item	Specification
<b>Environmental</b>	
Temperature, ambient operating	32 to 104°F (0 to 40°C)
Temperature, ambient nonoperating and storage	–40 to 167°F (–40 to 75°C)
Humidity (RH), ambient (noncondensing), operating	10 to 90%
Humidity (RH), ambient (noncondensing), nonoperating and storage	5 to 95%
Altitude, operating and nonoperating	–196 to 6561 ft (–60 to 2000 m)

**Table A-1 Catalyst 4503-E Switch Specifications (continued)**

Item	Specification
<b>Switching Components</b>	
Backplane	24 Gbps full duplex backplane
Port density	116 10/100/1000 ports when using a Catalyst 4500 Series Supervisor Engine II-Plus TS, 96 10/100/1000 ports with other supervisor engines, or 12 10-Gbps X2 ports  Two 10-Gbps Uplinks, and up to 12 10-Gbps ports on switching module slots
Inline power	integrated support, 820 W per switching module
<b>Physical Characteristics</b>	
Dimensions (H x W x D)	12.25" x 17.31" x 12.50" in 311.15 mm x 439.7 mm x 317.5 mm
Weight	Minimum weight: 32.25 lbs (14.65 kg) Maximum weight: 75 lbs (34 kg)  Chassis and backplane: 32.25 lbs (14.65 kg) Fan tray: 2.75 lbs (1.24 kg)
<b>Airflow</b>	
Switch	Right to left
Power supply	Front to back
<b>Power</b>	
PoE supplied	-48 VDC
Power to Modules and fans	12 VDC
Power to backplane components	3.3 VDC
<b>Redundancy</b>	
Supervisor engine	no
Power supply	1 + 1

## Catalyst 4506-E Switch Specifications

Table A-2 lists the Catalyst 4506-E switch specifications.

**Table A-2 Catalyst 4506-E Switch Specifications**

Item	Specification
<b>Environmental</b>	
Temperature, ambient operating ambient nonoperating and storage	32 to 104°F (0 to 40°C) -40 to 167°F (-40 to 75°C)
Humidity (RH), ambient (noncondensing): operating nonoperating and storage	10 to 90% 5 to 95%

**Table A-2 Catalyst 4506-E Switch Specifications (continued)**

Item	Specification
Altitude: operating and nonoperating	-196 to 6561 ft (-60 to 2000 m)
<b>Switching Components</b>	
Backplane	120 Gbps full duplex
Port density	240 (max) 10/100/1000 ports Two 10-Gbps Uplinks, and up to 30 10-Gbps ports on switching module slots
Inline power	integrated support, 820 W per line card
<b>Physical Characteristics</b>	
Dimensions (H x W x D)	17.38 x 17.31 x 12.5 in. (441.3 x 439.7 x 317.5 mm)
Weight	Minimum weight: 34.5 lbs (15.6 kg) Maximum weight: 100 lbs (45.4 kg) Chassis and backplane = 39.5 lbs (17.95 kg) Fan tray: 5.0 lbs (2.2 kg)
<b>Airflow</b>	
Switch	Right to left
Power supply	Front to back
<b>Power</b>	
PoE supplied	-48 VDC
Power to Modules and fans	12 VDC
Power to backplane components	3.3 VDC
<b>Redundancy</b>	
Supervisor engine	no
Power supply	1 + 1

## Catalyst 4507R-E Switch Specifications

Table A-3 lists the Catalyst 4507R-E switch specifications.

**Table A-3 Catalyst 4507R-E Switch Specifications**

Item	Specification
<b>Environmental</b>	
Temperature, ambient operating ambient nonoperating and storage	32 to 104°F (0 to 40°C) -40 to 167°F (-40 to 75°C)
Humidity (RH), ambient (noncondensing): operating nonoperating and storage	10 to 90% 5 to 95%

**Table A-3 Catalyst 4507R-E Switch Specifications (continued)**

Item	Specification
Altitude: operating nonoperating	–196 to 6561 ft (–60 to 2000 m) –1000 to 30,000 ft (–300 to 9150 m)
<b>Switching Components</b>	
Backplane	120 Gbps full duplex 4 Gbps Uplinks with Sup II+, Sup IV, and Sup 6-E with TwinGig converters 8 Gbps Uplinks with Supervisor Engine V two 10 Gbps Uplinks with Sup V-10GE and Sup 6-E
Port density	240 (max) 10/100/1000 ports  Two 10-Gbps Uplinks, and up to 30 10-Gbps ports on switching module slots
Inline power	integrated support, 820 W per line card
<b>Physical Characteristics</b>	
Dimensions (H x W x D)	19.15 x 17.22 x 12.5 in. (49 x 44 x 32 cm)
Weight	Minimum weight: 45.5 lbs (20.68 kg) Maximum weight: 100 lbs (45.4 kg)  Chassis and backplane: 45.5 lbs (20.68 kg) Fan tray: 6 lbs (2.7 kg)
<b>Airflow</b>	
Switch	Right to left
Power supply	Front to back
<b>Power</b>	
PoE supplied	–48 VDC
Power to Modules and fans	12 VDC
Power to backplane components	3.3 VDC
<b>Redundancy</b>	
Supervisor engine	yes
Power supply	1 + 1

# Catalyst 4510R-E Switch Specifications

Table A-4 lists the Catalyst 4510R-E switch specifications.

**Table A-4 Catalyst 4510R-E Switch Specifications**

Item	Specification
<b>Environmental</b>	
Temperature, ambient operating ambient nonoperating and storage	32 to 104°F (0 to 40°C) –40 to 167°F (–40 to 75°C)
Humidity (RH), ambient (noncondensing): operating nonoperating and storage	10 to 90% 5 to 95%
Altitude: operating nonoperating	–196 to 6561 ft (–60 to 2000 m) –1000 to 30,000 ft (–300 to 9150 m)
<b>Switching Components</b>	
Backplane	88 Gbps full duplex with Supervisor Engine V, 96 Gbps with Supervisor Engine V-10GE 386 Gbps with Supervisor Engine 6-E 4 Gbps Uplinks with Sup II+, Sup IV, and Sup 6-E with TwinGig converters 8 Gbps Uplinks with Supervisor Engine V 20 Gbps Uplinks with Supervisor Engine V-10GE two 10 Gbps Uplinks with Sup V-10GE and Sup 6-E
Port density	386 maximum 10/100/1000 ports Two 10-Gbps Uplinks, and up to 30 10-Gbps ports on switching module slots with Supervisor Engine 6-E
Inline power	integrated support, 820 W per line card
<b>Physical Characteristics</b>	
Dimensions (H x W x D)	24.35 x 17.31 x 12.5 in. (618.4 x 439.7 x 317.5 mm)
Weight	Minimum weight: 54.5 lbs (24.77 kg) Maximum weight: 108 lbs (45.4 kg) Chassis and backplane: 54.5 lbs (24.77 kg) Fan tray: 8.0 lbs (3.6 kg)
<b>Airflow</b>	
Switch	Right to left
Power supply	Front to back
<b>Power</b>	
PoE supplied	–48 VDC
Power to Modules and Fans	12 VDC
Power to backplane components	3.3 VDC

Table A-4 Catalyst 4510R-E Switch Specifications (continued)

Item	Specification
<b>Redundancy</b>	
Supervisor engine	yes
Power supply	1 + 1

## Catalyst 4500 Power Supplies

Tables A-5 through A-12 list the specifications for the Catalyst 4500 series power supplies, which can be used in any Catalyst 4500 E-series switch.



### Note

All Catalyst 4500 series switch AC-input power supplies require single-phase source AC. The source AC can be out of phase between multiple power supplies or multiple AC-power plugs on the same power supply because all AC power supply inputs are isolated. Each chassis power supply should have its own dedicated branch circuit: 15 A or 20 A for North America and circuits sized to local and national codes for International locations.

For more information about power management and planning, refer to the “Environmental Monitoring and Power Management” chapter in the *Catalyst 4500 Series Switch Cisco IOS Software Configuration Guide* version appropriate for your software.

**Table A-5 1000 W AC-Input Power Supply Specifications**

Item	Specification
Minimum software requirement	Cisco IOS Release 12.1(12c)EW
Power over Ethernet	Not supported <sup>1</sup>
AC-input type	Autoranging input with power factor corrector
AC-input voltage	100 to 240 VAC ( $\pm 10\%$ for full range)
AC-input current	12 A @ 100 VAC, 5 A @ 240 VAC
Maximum KVA rating	1.32 KVA
AC-input frequency	50/60 Hz (nominal) ( $\pm 3$ Hz for full range)
Power supply output capacity	1050 W plus 40 W (fan)
Power supply output	12 V @ 83.4 A, 3.3V @ 12.2 A, 1667 W maximum
Output holdup time	20 ms minimum
Max heat dissipation	943 BTUs/hr

1. A Catalyst 4503 with a Catalyst 4500 series Supervisor Engine II-Plus TS and a 1000W power supply will be able to provide 158.4 W of Power over Ethernet to ports on the supervisor engine. Switching modules in other slots will not be able to provide PoE.

**Table A-6 1300 W AC-Input Power Supply Specifications**

Item	Specification
Minimum software requirement	Cisco IOS Release 12.1(12c)EW
Power over Ethernet	Supported, up to 800 W (211 Cisco phones in combined mode)
AC-input type	Autoranging input with power factor corrector
AC-input voltage	100 to 240 VAC ( $\pm 10\%$ for full range)
AC-input current	16 A @ 100 VAC, 7 A @ 240 VAC
AC-input frequency	50/60 Hz (nominal) ( $\pm 3$ Hz for full range)
Maximum KVA rating	1.76 KVA
Power supply output	1300 W maximum 1050 W+ 40 W redundant mode (Data) 1667 W maximum in combined mode (Data)
Power supply output (AC supply)	800 W maximum each in redundant mode (PoE) 1333 W maximum in combined mode (PoE) 12 V @ 84.7 A, 3.3 V @ 12.5 A (Data), -50 V @ 16.7 A (PoE)
Max heat dissipation	1568 BTUs/hr
Output holdup time	20 ms minimum

**Table A-7 1400 W AC-Input Power Supply Specifications**

Item	Specification
Minimum software requirement	Cisco IOS Release 12.2(18)EW
Power over Ethernet	Not supported <sup>1</sup>
AC-input type	Autoranging input with power factor corrector
AC-input voltage	100 to 240 VAC ( $\pm 10\%$ for full range)
AC-input current	16 A @ 100 VAC, 7 A @ 240 VAC
AC-input frequency	50/60 Hz (nominal) ( $\pm 3$ Hz for full range)
Maximum KVA rating	1.76 KVA
Power supply output	2473 W maximum 1360 W+ 40 W redundant mode (Data)
Power supply output (AC supply)	12 V @ 113.4 A, 3.3 V @ 12.2 A (Data)
Max heat dissipation	1048 BTUs/hr
Output holdup time	20 ms minimum

1. A Catalyst 4503-E with a Catalyst 4500 series Supervisor Engine II-Plus TS and a 1400W AC power supply provides 158.4 W of PoE to ports on the supervisor engine. Switching modules in other slots will not be able to provide PoE.

**Caution**

Do not mix the 1400 W DC power supply with any other power supply, even for a hot swap or other short-term emergency. Doing so can seriously damage your switch.

The 1400W DC Input power supply may be used with the Catalyst 4500 Series AC Power Shelf. Documentation for the Catalyst 4500 Series AC Power Shelf is at:

[http://www.cisco.com/en/US/docs/switches/lan/catalyst4500/hardware/configuration/notes/78\\_15068.html](http://www.cisco.com/en/US/docs/switches/lan/catalyst4500/hardware/configuration/notes/78_15068.html)

**Table A-8 1400 W DC-Input Power Supply Specifications**

Item	Specification
Minimum software requirement	Cisco IOS Release 12.1(19)EW
Power over Ethernet	Supported, up to 7500 W minus power consumed for data (240 Cisco phones in combined mode)
DC-input voltage	Data only: -48 to -60 VDC Inline devices: -48 to -56 VDC
DC-input current	Data only: 31 A @ -60 VDC Data and inline devices: 180 A maximum @ -48 VDC input <b>Note</b> The input power is configurable in the CLI. The Cisco IOS command is <b>power dc input</b> . Configure the switch software to match the requirements of your switch. To learn how to calculate the DC input current for your system, refer to the “Calculating DC Input Current” section on page 2-9.



**Table A-8 1400 W DC-Input Power Supply Specifications (continued)**

<b>Item</b>	<b>Specification</b>
Input power	1866 W (Data only)
Current draw At -40.5 V (min voltage)	46 A
Current draw at -72 V (max voltage)	25.9 A
Max heat dissipation at 1866 W	5760 BTUs
	179 A max @ 48 VDC
Maximum KVA rating	1.87 (data) 9.15 (data and voice)
Power supply output (DC supply)	Data: 12 V @ 120 A, 3.3 V @ 10 A Inline devices: 140 A total maximum (35 A maximum each per 5 channels) @ -48 to 60 VDC input 1367 W+ 40 W redundant mode (Data) 2267 W maximum in combined mode (Data)
DC input terminal block	7500 W maximum each in redundant mode (PoE) 7280 W maximum in combined mode (PoE) Accepts FCI p/n YAV25L2TC14FX90 or equivalent, barrel-type lug terminals with 90-degree angle, two-hole tongue, which accommodates 1/0 AWG size copper wire. The connector tongue width is 0.82 in, the stud hole spacing is 5/8 in, and the hole size is 1/4 in.
Output holdup time	4 ms
Max heat dissipation	1591 BTUs/hr (data) 2905 BTUs/hr (data and voice)
<b>Catalyst 4503-Specific Power Usage (data only)</b>	
Maximum draw	475 W
Maximum input	633 W
Current draw at -40.5 V (min voltage)	15.6 A
Current draw at -72 V (max voltage)	8.8 A
Max heat dissipation at 633 W	2160 BTUs
<b>Catalyst 4506-Specific Power Usage (data only)</b>	
Maximum draw (data only)	850 W
Maximum input	1133 W
Current draw at -40.5 V (min voltage)	28 A
Current draw at -72 V (max voltage)	15.8 A
Max heat dissipation at 1133 W	3515 BTUs
<b>Catalyst 4507R-E Specific Power Usage (data only)</b>	
Maximum draw (data only)	1080 W
Max input is 1080 W / 0.75 =	1440 W

**Table A-8 1400 W DC-Input Power Supply Specifications (continued)**

Item	Specification
Current draw at -40.5 V (min voltage)	35.6 A
Current draw at -72 V (max voltage)	20 A
Max heat dissipation 1440 W	4910 BTUs

**Table A-9 1400 W DC Triple-Input Power Supply Specifications**

Item	Specification
Minimum software requirement	Cisco IOS Release 12.2(25)EW
Power over Ethernet	Not supported
DC-input voltage	Domestic and international: -48 to -60 VDC
DC-input current	42.5 A maximum @ -48 VDC input Input 1: 12.5 A at -48 to -60 VDC Input 2: 15 A at -48 to -60 VDC Input 3: 15 A at -48 to -60 VDC
Input power	1772 W @ 1400 W output power
Current draw At -40.5 V (min voltage)	42.5 A
Current draw at -72 V (max voltage)	25 A
Max heat dissipation at 1400 W	1269 BTUs
Maximum KVA rating	1.77 at 1400 W load
Power supply output (DC supply)	12 V @ 8 A minimum, 115.3 A maximum 3.3 V @ 1.2 A minimum, 12.5 A maximum 1360 W+ 40 W redundant mode 2450 W maximum in combined mode
DC input terminal block	Model: Cooper Bussmann Magnum. Accepts terminals with flat angle, one hole tongue, which accommodates 10 to 12 AWG size copper wire. The connector the barrier spacing is 0.378 in (9.6 mm), and the screw size is 8-32.
Output holdup time	8 ms
Max heat dissipation	1269 BTUs/hr

**Table A-9 1400 W DC Triple-Input Power Supply Specifications (continued)**

Item	Specification
<b>Catalyst 4503-E Specific Power Usage (data only)</b>	Two modules minimum required @ -40.5 VDC input One 15A module minimum required @ -44 VDC input
Maximum draw	475 W
Maximum input	609 W total / # of modules = W per module
Current draw at -40.5 V (min voltage)	15 A total / # of modules = A per module
Current draw at -72 V (max voltage)	8.5 A total / # of modules = A per module
Max heat dissipation at 609 W	2078 BTUs
<b>Catalyst 4506-E Specific Power Usage (data only)</b>	Two modules minimum required @ -44 VDC input Three modules minimum required @ -40.5 VDC input
Maximum draw (data only)	850 W
Maximum input	1076 W total / # of modules = W per module
Current draw at -40.5 V (min voltage)	26.6 A total / # of modules = A per module
Current draw at -72 V (max voltage)	15 A total / # of modules = A per module
Max heat dissipation at 1076 W	3671 BTUs
<b>Catalyst 4507R-Specific Power Usage (data only)</b>	Three modules minimum required
Maximum draw (data only)	1080 W
Max input is 1080 W	1367 W total / # of modules = W per module
Current draw at -40.5 V (min voltage)	33.75 A total / # of modules = A per module
Current draw at -72 V (max voltage)	19 A total / # of modules = A per module
Max heat dissipation 1367 W	4665 BTUs

**Table A-10 Input Modes**

Input Mode	Input Number	Input Configuration	Maximum Total Output Power
1	1	1 x 12.5 A	386 W @ -40.5 VDC 412 W @ -44.0 VDC
2	2 OR 3	1 x 15 A	466 W @ -40.5 VDC 495 W @ -44.0 VDC
3	1, 2 OR 3	1 x 12.5 A and 1 x 15 A	845 W @ -40.5 VDC 908 W @ -44.0 VDC
4	2, 3	2 x 15 A	914 W @ -40.5 VDC 990 W @ -44.0 VDC
5	1, 2, 3	1 x 12.5 A and 2 x 15 A	1294 W @ -40.5 VDC 1400 W @ -44.0 VDC

**Table A-11 Allowable Power with Two 1400 W DC Triple-Input Power Supplies in Combined Mode**

PS1/PS2	1	2 or 3	1 and (2 or 3)	2 and 3	1 and 2 and 3
1	824 W	907 W	1320 W	1400 W	1700 W
2 or 3	907 W	990 W	1400 W	1450 W	1750 W
1 and (2 or 3)	1320 W	1400 W	1700 W	1750 W	1900 W
2 and 3	1400 W	1450 W	1750 W	1820 W	2130 W
1 and 2 and 3	1700 W	1750 W	1900 W	2130 W	2450 W

**Table A-12 2800 W AC-Input Power Supply Specifications**

Item	Specification
Minimum software requirement	Cisco IOS Release 12.1(13)EW
Power over Ethernet	Supported, up to 1400 W (240 Cisco phones in combined mode)
AC-input type	Autoranging input with power factor corrector
AC-input voltage	200 to 240 VAC ( $\pm 10\%$ for full range)
AC-input current	16 A maximum at 200 VAC
AC-input frequency	50/60 Hz (nominal) ( $\pm 3\%$ for full range)
Maximum KVA rating	3.52 KVA
Power supply output	2800 W maximum 12 V @ 113.3 A, 3.3 V @ 12.1 A (Data) -50 V @ 28 A (PoE) 1360 W+ 40 W redundant mode (Data) 2473 W maximum in combined mode (Data)
Max heat dissipation	2387 BTUs/hr.
Output holdup time	20 ms minimum

**Table A-13 4200 W AC-Input Power Supply Specifications**

Item	Specification
Minimum software requirement	Cisco IOS Release 12.2(25)EWA
Power over Ethernet	Supported, up to 4200 W
AC-input type	Autoranging input with power factor corrector
AC-input voltage	100 to 240 VAC ( $\pm 10\%$ for full range)
AC-input current	16 A maximum at 200 VAC
AC-input frequency	50/60 Hz (nominal) ( $\pm 3\%$ for full range)

**Table A-13 4200 W AC-Input Power Supply Specifications**

Item	Specification
Maximum KVA rating	5.25 KVA
Power supply output	4200 W maximum @ 230 VAC 12 V @ 115.3 A, 3.3 V @ 12.5 A (Data) -50 V @ 77.1 A (PoE) with two inputs  2100 W maximum @ 230 VAC 12 V @ 115.3 A, 3.3 V @ 12.5 A (Data) -50 V @ 38.5 A (PoE) with one input  2100 W maximum @ 120 VAC 12 V @ 115.3 A, 3.3 V @ 12.5 A (Data) -50 V @ 38.0 A (PoE) with two inputs  1050 W maximum @ 120 VAC 12 V @ 55.9 A, 3.3 V @ 12.5 A (Data) -50 V @ 14.6 A (PoE) with one input
Max heat dissipation	3583 BTUs/hr.
Output holdup time	20 ms minimum

**Note**

The 4200 W AC power supply should not be used in mixed-voltage configurations. All the inputs in a chassis must be at the same voltage (110 VAC or 220 VAC).

Table A-14 shows the wattage output possible with the 4200W power supply in redundant mode. In redundant mode, both power supplies must have identical inputs and all inputs must be at the same voltage. If the input voltages are mismatched, choose the value matching the weaker of the two power supplies.

**Table A-14 Redundant Mode Output**

	12V	3.3V	-50V	Total
110	660	40	700	1050
110+110 or 220	1360	40	1850	2100
220+220	1360	40	3700	4200

Table A-15 shows the wattage output possible with the 4200 W power supply in combined mode.

**Table A-15 Combined Mode Output**

	12 V	3.3 V	-50 V	Total
Both sides at 110	1200	40	1200	1873
110+110, other side 110	1360	40	2000	2728
220+220	1360	40	3100	3782
Both sides at 110+110	1360	40	3100	3782

**Table A-15 Combined Mode Output**

	12 V	3.3 V	-50 V	Total
Both sides at 220	1360	40	4700	5493
Both sides at 220+220	1360	40	6800	7600

**Table A-16 AC and DC Power Information and Heat Dissipation Specifications**

Module Type/ Model Number	AC or DC Input Power (W)	DC Output Power (W)	Reset Mode (W)	Heat Dissipation (BTU/Hr)	Input Current at 90 VAC (A)	Input Current at 120 VAC (A)	Input Current at 180 VAC (A)	Input Current at 240 VAC (A)
Catalyst 4503-E chassis (with fans)	80	60	—	273	0.89	0.67	0.44	0.33
Catalyst 4506-E chassis (with fans)	160	120	—	546	1.78	1.33	0.89	0.67
Catalyst 4507R-E chassis (with fans)	180	135	—	614	2.00	1.50	1.00	0.75
Catalyst 4510R-E chassis (with fans)	267	200	—	909	2.96	2.22	1.48	1.11
WS-X45-SUP6-E	347	200	200	1182	3.85	2.89	1.93	1.44
WS-X4606-X2-E	173	130	80	227	0.74	0.56	0.37	0.28
WS-X4648-RJ45V-E	123	92	10	418	1.36	1.02	0.68	0.51
WS-X4648-RJ45V+E	123	92	10	418	1.36	1.02	0.68	0.51

**Table A-17 DC Power Requirements and Heat Dissipation Specifications**

Model Number/ Module Type	DC Input Power (W)	DC Output Power (W)	Heat Dissipation (BTU/Hr)	Input Current at -42 VDC (A)	Input Current at -48 VDC (A)	Input Current at -52 VDC (A)	Input Current at -58 VDC (A)
Catalyst 4503-E chassis (with fans)	80	60	273	1.90	1.67	1.54	1.38
Catalyst 4506-E chassis (with fans)	160	120	546	3.81	3.33	3.08	2.76
Catalyst 4507R-E chassis (with fans)	180	135	614	4.29	3.75	3.46	3.10
Catalyst 4510R-E chassis (with fans)	276	200	909	6.35	5.56	5.13	4.60
WS-X45-SUP6-E	347	200	1182	8.25	7.22	6.67	5.98
WS-X4606-X2-E	66.67	130	227	1.59	1.39	1.28	1.15
WS-X4648-RJ45V-E	122.67	92	418	2.92	2.56	2.31	2.07
WS-X4648-RJ45V+E	122.67	92	418	2.92	2.56	2.36	2.11



## APPENDIX **B**

### Repacking a Switch

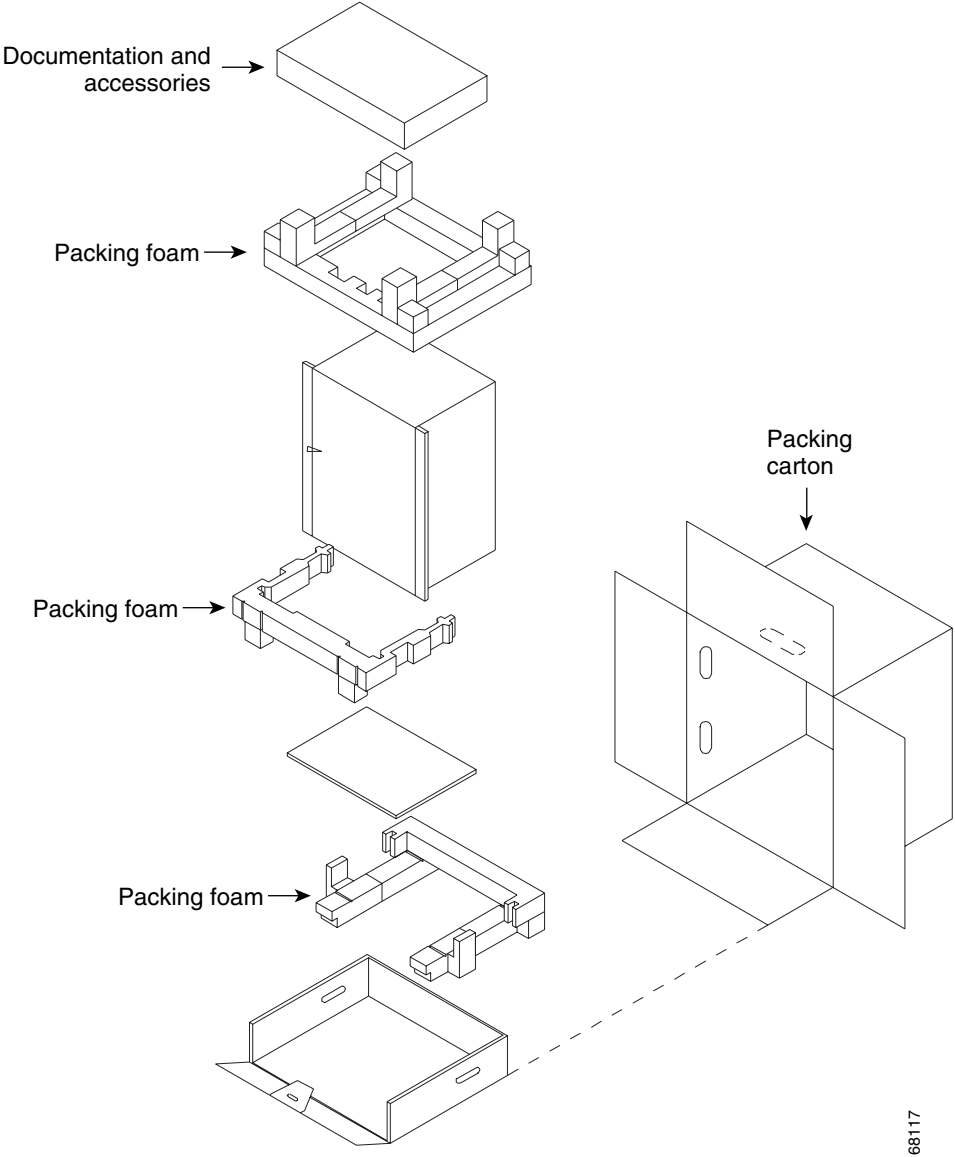
---

If you need to return your Catalyst 4500 E-series switch to the factory, use the instructions in this appendix to repack your switch in preparation for shipping.

To repack the switch using the original packaging material, follow these steps:

- 
- Step 1** Slide the pieces of the packing foam over the Catalyst 4500 E-series switch. (See Figure B-1.)
  - Step 2** Place the documentation and accessory kit in the box or poly bag provided.
  - Step 3** Place the box or poly bag containing the documentation and accessory kit on top of the packing material.
  - Step 4** Place the switch (with packing foam pieces) into the packing carton.
  - Step 5** Fold in the top flaps of the packing carton and seal with packing tape.
-

Figure B-1 Catalyst 4500 E-series Switch Packing Material



68117





# APPENDIX **C**

## Initial Configuration for the Switch

---

This chapter provides a quick step-by-step initial setup procedure for a switch.

These steps describe how to do a simple installation:

1. Connecting to the Switch, page C-2
2. Starting the Terminal-Emulation Software, page C-2
3. Connecting to a Power Source, page C-2
4. Entering the Initial Configuration Information, page C-3



**Note**

---

If you are using a DC power supply, see the “Power Connection Guidelines for DC-Powered Systems” section on page 2-9 for more information about setting up your switch with a DC power supply.

---



**Note**

---

You need to provide the Category 5 straight-through cables to connect the switch ports to other Ethernet devices.

---



**Note**

---

If you move a supervisor engine from a Catalyst 4500 series chassis to a Catalyst 4503-E chassis or Catalyst 4506-E chassis, it must use Cisco IOS Release 12.2(37)SG or later. Refer to the release note for software upgrade procedures if needed:

[http://www.cisco.com/en/US/docs/switches/lan/catalyst4500/release/note/OL\\_5184.html#wp305142](http://www.cisco.com/en/US/docs/switches/lan/catalyst4500/release/note/OL_5184.html#wp305142)

---

## Connecting to the Switch

You must use the console port to perform the initial configuration. To connect the switch console port to a PC, use the supplied RJ-45-to-DB-9 adapter cable.

Follow these steps to connect the PC or terminal to the switch:

- 
- Step 1** Using the supplied RJ-45-to-DB-9 adapter cable, insert the RJ-45 connector into the console port that is located on the front of the supervisor engine.
- Step 2** Attach the DB-9 female DTE of the adapter cable to a PC serial port, or attach an appropriate adapter to the terminal.
- 

## Starting the Terminal-Emulation Software

Before you power on the switch, start the terminal-emulation session so that you can see the output display from the power-on self-test (POST).

The terminal-emulation software—frequently a PC application such as Hyperterminal or ProcommPlus—makes communication between the switch and your PC or terminal possible.

- 
- Step 1** Start the terminal-emulation program if you are using a PC or terminal.
- Step 2** Start a terminal-emulation session.
- Step 3** Configure the baud rate and character format of the PC or terminal to match these console port default characteristics:
- 9600 baud
  - 8 data bits
  - 1 stop bit
  - No parity
  - None (flow control)
- 

## Connecting to a Power Source

Follow these steps to connect to a power source:

- 
- Step 1** If you are using an AC power supply, connect one end of the supplied AC power cord to the power connector on the switch, and then connect the other end of the power cable to a grounded AC outlet.
- Step 2** If you are using a DC power supply, see the instructions on how to install the DC power supply in Chapter 3, “Installing the Switch in a Rack.”
-

As the switch powers on, it begins the POST, a series of tests that runs automatically to ensure that the switch functions properly.

POST lasts approximately 1 minute. After POST is complete, the system and status LEDs remain green.

If the switch fails POST, the system LED turns amber.

**Note**

---

POST failures are usually fatal. Call Cisco Systems if your switch does not pass POST.

---

If you started the terminal-emulation program before you powered on your switch, the PC or terminal displays the bootloader sequence. You need to press Enter to display the setup program prompt.

## Entering the Initial Configuration Information

To set up the switch, you need to assign an IP address and other configuration information necessary for the switch to communicate with the local routers and the Internet. The minimal configuration provided here does not cover most of the features, it simply allows you to perform other configuration tasks using a telnet connection from your management network. To configure other features and interfaces, please refer to the *Catalyst 4500 Series Switch Software Configuration Guide*.

### IP Settings

You will need this information from your network administrator:

- Switch IP address
- Subnet mask (IP netmask)
- Default gateway (router)
- Enable secret password
- Enable password
- Telnet password

### Performing the Initial Configuration

Follow these steps to complete the initial configuration for the switch:

---

**Step 1** At the terminal prompt, enter the enable command to enter privileged exec mode:

```
Switch> enable
Password: password
Switch#
```

**Step 2** Set the system time using the **clock set** command in privileged EXEC mode.

```
Switch# clock set 20:09:01 3 Apr 2006
```

**Step 3** Verify the change by entering the **show clock** command.

```
Switch# show clock
20:09:06.079 UTC Thu Apr 3 2006
```

- Step 4** Enter the **configure terminal** command to enter global configuration mode.

```
Switch# configure terminal
Enter configuration commands, one per line. End with CNTL/Z.
Switch (config)#
```

- Step 5** Configure the system prompt and host name for the switch, and press **Return**. To remove the new prompt and return the prompt to its default, use the **no hostname** command.

```
Switch (config)# hostname Switch1
```

- Step 6** Use the **banner motd** global configuration command to set location information in the login banner. You can also set a system contact using this command.

```
Switch1(config)# banner motd c 170 West Tasman Drive, San Jose, CA c
```

or

```
Switch1 (config)# banner motd c 170 West Tasman Drive, San Jose, CA; Tech Support 408 123 4567 c
```

- Step 7** Configure an enable secret password, and press **Return**.

The password can be from 1 to 25 alphanumeric characters, can start with a number, is case sensitive, allows spaces, but ignores leading spaces. The secret password is encrypted and the enable password is in plain text.

```
Switch1 (config)# enable secret SecretPassword
```

- Step 8** Configure an enable password, and press **Return**.

```
Switch1 (config)# enable password EnablePassword
```

- Step 9** Configure a virtual terminal (Telnet) password, and press **Return**.

The password can be from 1 to 25 alphanumeric characters, is case sensitive, allows spaces, but ignores leading spaces.

```
Switch1 (config)# password terminal-password
Switch1 (config)# line vty 0 15
```

- Step 10** Configure the interface that connects to the management network. (The IP address and subnet mask shown are for example only. Use an address appropriate for your network.)

```
Switch1 (config)# ip routing
Switch1 (config)# interface gigabitethernet 3/24
Switch1 (config-if)# no switchport
Switch1 (config-if)# no shutdown
Switch1 (config-if)# ip address 10.4.120.106 255.0.0.0
Switch1 (config-if)# exit
```

- Step 11** Exit from global configuration mode:

```
Switch (config)# exit
Switch #
```

- Step 12** View the configuration you just created and confirm that it is what you want.

```
Switch1# show run
!
hostname Switch1
!
banner motd ^C
170 West Tasman Drive, San Jose, CA ^C
!
```

```
!--- Output suppressed.
```

**Step 13** Configure a default route:

```
Switch1(config)#ip route 0.0.0.0 0.0.0.0 172.16.1.1
```

**Step 14** Verify the IP information by using the **show ip interface brief** and **show ip route** commands.

```
Switch1# show ip interface brief
```

Interface	IP-Address	OK?	Method	Status	Protocol
Vlan1	10.4.220.206	YES	manual	up	up
FastEthernet1	unassigned	YES	unset	up	up

```
!--- Output suppressed.
```

```
Switch1# show ip route
```

```
Codes: C - connected, S - static, I - IGRP, R - RIP, M - mobile, B - BGP
       D - EIGRP, EX - EIGRP external, O - OSPF, IA - OSPF inter area
       N1 - OSPF NSSA external type 1, N2 - OSPF NSSA external type 2
       E1 - OSPF external type 1, E2 - OSPF external type 2, E - EGP
       i - IS-IS, L1 - ISIS level-1, L2 - ISIS level-2, ia - ISIS inter area
       * - candidate default, U - per-user static route, o - ODR
       P - periodic downloaded static route
```

```
Gateway of last resort is 172.16.1.1 to network 0.0.0.0
```

```
       172.16.0.0/24 is subnetted, 1 subnets
       C       172.16.1.0 is directly connected, Vlan1
       S*    0.0.0.0/0 [1/0] via 172.16.1.1
Switch1#
```

**Step 15** Save the running configuration:

```
Switch1# copy system:running-config nvram:startup-config
```

You have now completed the initial configuration of the switch, so you may now configure other interfaces and features over a network connection without having to directly connect to the console port of the supervisor engine.

---

To use the CLI to perform additional configuration or management tasks, enter commands at the Switch> prompt through the console port by using a terminal program or through the network by using Telnet. For configuration information, refer to the switch software configuration guide or the switch command reference.





# APPENDIX **D**

## Module Overview and Specifications

---

This chapter provides an overview of the features of the Catalyst 4500 E-series supervisor engine and switching modules. The information is presented in the following major sections:

- Catalyst 4500 Series Switches, page D-1
- Catalyst 4500E Series Switches, page D-1
- Supervisor Engines, page D-1
- Switching Modules, page D-4
- Switching Module LEDs, page D-7
- Hot-Swapping Feature, page D-8

### Catalyst 4500 Series Switches

The Catalyst 4500 series switches consist of the Catalyst 4503 switch, the Catalyst 4506 switch, the Catalyst 4507R switch, and the Catalyst 4510R switch. The switches are designed for high-performance, high-density wiring closet applications. A detailed overview of these switches is in the *Catalyst 4500 Series Installation Guide*.

### Catalyst 4500 E-Series Switches

The Catalyst 4500E series switches consist of the Catalyst 4503-E switch, the Catalyst 4506-E switch, the Catalyst 4507R-E switch, and the Catalyst 4510R-E switch. The switches are designed for high-performance, high-density wiring closet applications.

### Supervisor Engines

Catalyst 4500 E-series switches can use many of the same supervisor engines and switching modules as the Catalyst 4500 series switches. This section describe the supervisor engine newly available for the Catalyst 4500 E-series switches or Catalyst 4500 classic switches:

- Catalyst 4500 E-Series Supervisor Engine 6-E, WS-X45-Sup6-E<sup>1</sup>

1. A WS-X45-Sup6-E will work in a Catalyst 4500 series classic switch, but will only support 6 Gbps per slot.

On the Catalyst 4503-E and 4506-E switches, you can install the Supervisor Engine in slot 1 only. On the Catalyst 4507R-E switch, you install the primary supervisor engine in slot 3, and you can install an optional redundant supervisor engine in slot 4. On the 4510R-E switch, you install the primary supervisor engine in slot 5, and you can install an optional redundant supervisor engine in slot 6.

The supervisor engines have the following features:

- Data path and control for all network interfaces
- Management functions:
  - Interface monitoring
  - Environmental status
  - SNMP and console/Telnet interface
- Hot-swapping

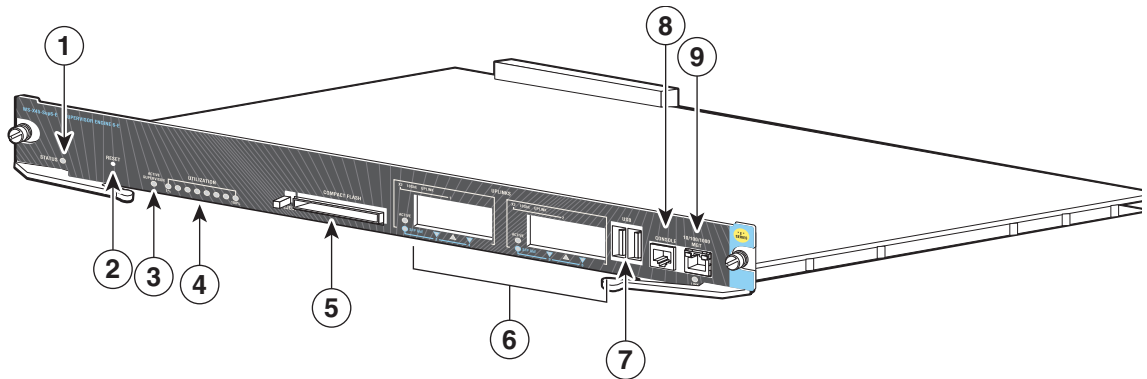


**Note** Packets are not forwarded while the module is removed. A system reboot occurs when a supervisor engine is reinserted.

To install a supervisor engine, follow the procedure in its installation note.

The supervisor engine introduced with Catalyst 4500-E switches is shown in Figure D-1.

**Figure D-1 Supervisor Engine 6-E, 2x10GE(X2) w/ Twin Gig (WS-X45-Sup6-E)**



<b>1</b>	Status LED	<b>6</b>	Uplink ports
<b>2</b>	Reset button	<b>7</b>	USB port
<b>3</b>	Active Supervisor LED	<b>8</b>	Console port
<b>4</b>	Utilization LEDs	<b>9</b>	Management port
<b>5</b>	Compact flash port		



## Front-Panel Components

The following connectors, LEDs, and buttons are located on the front panel of the supervisor engine:

- The STATUS LED, which indicates the operating state of the module
- Four SFP Gigabit uplinks ports (via the Twin Gig converter) or 2 10-Gigabit X2 uplink ports
- Eight unmarked switch load indicator LEDs, which provide an approximation of the current traffic across the backplane
- A console port (RJ-45)
- An Ethernet management port (RJ-45)
- A link status LED, which provides status for the management port (10/100BASE-T on the WS-X4516-10GE supervisor engine)
- The Reset button (recessed), which allows you to reset the system
- The Compact Flash port and eject button (refer to *Using the Compact Flash on the Catalyst 4500 Supervisor Engines.*)
- The Twin Gig ports are the modules described in [http://www.cisco.com/en/US/products/ps7077/prod\\_module\\_installation\\_guide09186a00807e0ca4.html](http://www.cisco.com/en/US/products/ps7077/prod_module_installation_guide09186a00807e0ca4.html)

Table D-1 describes the supervisor engine LEDs.

**Table D-1 Supervisor Engine LEDs**

LED	Color/State	Description
STATUS	Green	Indicates the results of a series of self-tests. All diagnostic tests passed.
	Red	A test failed.
	Orange	System boot or diagnostic test is in progress.
	Off	Module is disabled.
UTILIZATION	Green 1–100%	If the switch is operational, this display indicates the current traffic load over the backplane (as an approximate percentage).
LINK	Green	Indicates the status of the 10/100BASE-T Ethernet management port or uplink ports. The link is operational.
	Orange	The link is disabled by user.
	Flashing orange	The power-on self-test indicates a faulty port.
	Off	No signal is detected or there is a link configuration failure.
ACTIVE	Green	Indicates whether the uplink port is active or not. The port is active.
	Off	The port is not active.

## Ethernet Management Port

The WS-X4013+10GE supervisor engine modules have a 10/100/1000BASE-T Ethernet management port. Supervisor engines use an RJ-45 connector on the front panel with a link status LED. For the location of the port, see Figure D-1 (WS-X4516-10GE).

TCP/IP-based management services available through inband access also are provided through this port (Telnet and SNMP). This management port also supports image download.


**Note**

The 10BASE-T and 10/100BASE-T Ethernet management ports are for network management only. These ports do not support network switching.

## Console Port

The console port is an RJ-45 receptacle. The console port allows you to perform the following functions:

- Configure the switch from the CLI
- Monitor network statistics and errors
- Configure SNMP agent parameters
- Download software updates to the switch or distribute software images residing in Flash memory to attached devices


**Note**

EIA/TIA-232 was known as recommended standard RS-232 before its acceptance as a standard by the Electronic Industries Association (EIA) and Telecommunications Industry Association (TIA).

## Supervisor Memory

Table D-2 lists the memory and processor specifications for the Supervisor engine.

**Table D-2**      **Supervisor Memory**

Supervisor Engine	
Supervisor Engine 6-E	512 GB SDRAM Upgradeable to 1GB 128 MB Flash memory 512 KB NVRAM

## Switching Modules

This section describes the Catalyst 4500 E-series Gigabit Ethernet switching modules and includes the following sections:

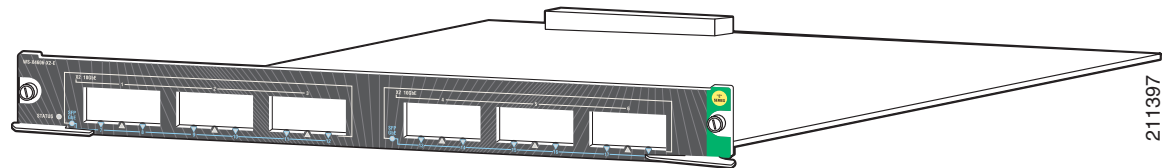
- WS-X4606-X2-E, page D-5
- WS-X4648-RJ45V-E, page D-5
- WS-X4648-RJ45V+E, page D-6
- Switching Module LEDs, page D-7

## WS-X4606-X2-E

The WS-X4606-X2-E 6-Port 10GbE (X2) switching module (see Figure D-2) has the following specifications:

Specification	Description
Module type	10Gig X2 or TwinGig fiber Ethernet switching module
Port duplex mode	Full duplex mode
Port speed	10 Gbps or 2 Gbps when using a Cisco TwinGig converter and 2 SFPs
Number of ports	6
Connector type	SC type
Cable type	MMF or SMF

**Figure D-2** WS-X4606-GB 6-Port Gigabit Ethernet Switching Module

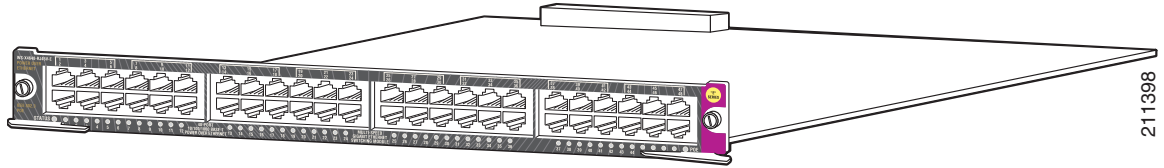


## WS-X4648-RJ45V-E

The WS-X4648-RJ45V-E 48-Port PoE 802.3af 10/100/1000(RJ45) switching module (see Figure D-3) has the following specifications:

Specification	Description
Module type	10/100/1000BASE-T Fast Ethernet switching module with IEEE802.3af PoE
Port duplex mode	Half or full duplex mode
Jumbo frame support	No
Port speed	10, 100, or 1000 Mbps
Number of ports	48
Connector type	RJ-45
Cable type	Category 5
Power over Ethernet	15.4 W per powered device on all 48 ports

**Figure D-3** *WS-X4548-GB-RJ45V-E 48-Port IEEE-Compliant PoE 10/100/1000BASE-T Switching Module*



To provide PoE with the 48-port PoE 10/100/1000BASE-T switching module in a Catalyst 4500 E-series switch, you must have an PoE-enabled power supply. All power supplies support PoE except the 1000 W and 1400 W AC power supplies.

**Note**

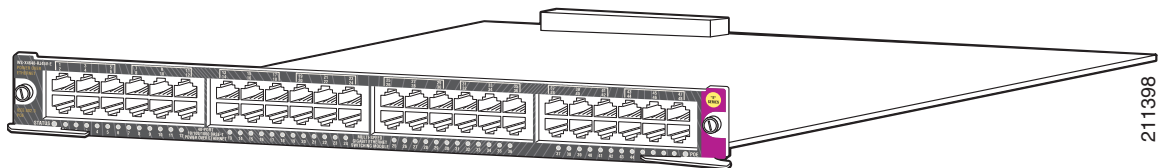
Auto MDIX is supported on this PoE enabled switching module.

## WS-X4648-RJ45V+E

The WS-X4648-RJ45V+E 48-Port Premium PoE 10/100/1000(RJ45) switching module (see Figure D-3) has the following specifications:

Specification	Description
Module type	10/100/1000BASE-T Fast Ethernet switching module with IEEE802.3af PoE
Port duplex mode	Half or full duplex mode
Jumbo frame support	Yes
Port speed	10, 100, or 1000 Mbps
Number of ports	48
Connector type	RJ-45
Cable type	Category 5
Power over Ethernet	15.4 W per powered device on all 48 ports, software upgradeable to 30W per port

**Figure D-4** *WS-X4548-GB-RJ45V+E 48-Port Premium PoE 10/100/1000BASE-T Switching Module*



To provide PoE with the 48-port PoE 10/100/1000BASE-T switching module in a Catalyst 4500 E-series switch, you must have an PoE-enabled power supply. All power supplies support PoE except the 1000 W and 1400 W AC power supplies.

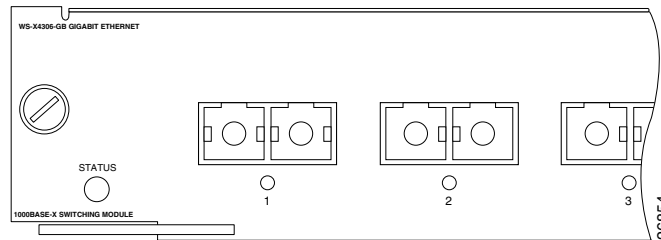
**Note**

Auto MDIX is supported on this PoE enabled switching module.

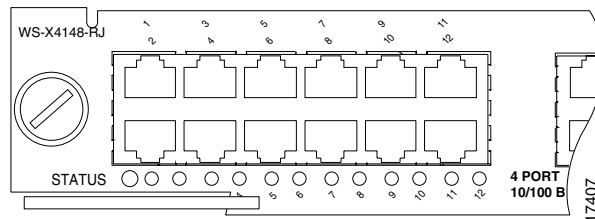
## Switching Module LEDs

Each switching module has one LED labeled STATUS that provides information about the module and one numbered LED labeled LINK for each port on the module. Figure D-5 shows the Gigabit Ethernet port and status LEDs. Figure D-6 shows the 10/100BASE-T port LEDs. Table D-3 describes the switching module LEDs.

**Figure D-5 Gigabit Ethernet Port and Status LEDs**



**Figure D-6 10/100BASE-T Port LEDs**



**Table D-3 Switching Module LEDs**

LED	Color/State	Description
STATUS		Indicates the results of a series of self-tests and diagnostic tests performed by the switch.
	Green	All the tests pass.
	Red	A test other than an individual port test failed.
	Orange	System boot, self-test diagnostics running, or the module is disabled.
LINK <sup>1</sup>	Green	The port is operational (a signal is detected).
	Orange	The link has been disabled by software.
	Flashing orange	The link has been disabled due to a hardware failure.
	Off	No signal is detected.
Port Status <sup>2</sup>		Indicates individual port status.
	Green	The port is operational (a signal is detected).
	Orange	The link has been disabled by software.

**Table D-3 Switching Module LEDs (continued)**

LED	Color/State	Description
	Flashing orange	The link has been disabled due to a hardware failure.
	Off	No signal is detected.

1. Used on the WS-X4232-L3 Ethernet routing module.
2. LEDs labeled 1 through the number of ports on the switching module are the individual port link LEDs.

## Hot-Swapping Feature

Catalyst 4500 E-series switches allow you to remove and replace switching modules without powering down the switch. This feature is known as *hot swapping*.

When you remove or insert a switching module while the switch is operating, the system does the following:

1. Scans the backplane for configuration changes.
2. Initializes all newly inserted switching modules, notes any removed modules, and places them in the administratively shutdown state.
3. Places any previously configured interfaces on the switching module back to the state they were in when they were removed. Any newly inserted interfaces are put in the administratively shutdown state, as if they were present (but unconfigured) at boot time. If you insert a similar switching-module type into a slot, its ports are configured and brought online up to the port count of the original switching module.

The system runs diagnostic tests on any new interfaces. If the test passes, the system is operating normally. If the new switching module is faulty, the system resumes normal operation but places the new module in the “faulty” state.

If the diagnostic test fails, the system crashes, which usually indicates that the new switching module has a problem and should be removed.



### Caution

To avoid erroneous failure messages, allow at least 15 seconds for the system to re initialize, and note the current configuration of all interfaces before you remove or insert another switching module.

When you hot swap switching modules, the system displays status messages on the console screen. The following sample display shows the messages logged by the system when a switching module is removed from slot 2:

```
Console> (enable)
2001 Sep 09 12:23:26 %SYS-5-MOD_REMOVE:Module 3 has been removed
Console> (enable)
2001 Sep 09 12:23:44 %SYS-5-MOD_INSERT:Module 3 has been inserted
Console> (enable)
2001 Sep 09 12:23:47 %SYS-5-MOD_OK:Module 3 is online
Console> (enable)
```

If you use the **show port** command to query the module before reinstalling a module to replace the removed one, the system responds, “Module 3 is not installed.” When the module is reinserted, the system recognizes the module as ready again.



## INDEX

---

### Numerics

#### 10/100BASE-T

- Ethernet management port **D-4**
- port LEDs **5-8, D-7**

#### 1000BASE-T

- interfaces **1-3, 1-6, 1-10, 1-14**

#### 1000BASE-X

- Ethernet interfaces **1-17**
- port and status LEDs (figure) **5-8, D-7**

#### 1000 W power supplies

- power cord plugs **2-4**
- power cords (table) **2-5**

#### 100BASE-T

- interfaces **1-3, 1-6, 1-10, 1-14**

#### 10BASE-T

- Ethernet management ports **D-4**
- interfaces **1-3, 1-6, 1-10, 1-14**

#### 1300 W power supplies

- power cord plugs **2-4**
- power cords (table) **2-5**

#### 1400 W power supplies

- power cord plugs **2-4**
- power cords (table) **2-5**

#### 2800 W power supplies

- power cord plugs **2-4**
- power cords (table) **2-7**

---

### A

#### AC-input power cords

- product numbers (table) **2-5**

#### AC-input power supplies

description **1-25**

environmental monitoring **1-29**

figure **1-26, 4-3**

handling (figure) **4-6**

installing **4-6**

removing **4-4**

replacing **4-6**

source circuit requirements **2-3**

troubleshooting **5-4**

verifying operation **4-7**

See also DC-input power supplies

#### ACTIVE LED

description (table) **1-22**

air-conditioning requirements **2-3**

#### airflow

Catalyst 4503-E switches (table) **A-2**

Catalyst 4506-E switches (table) **A-3**

Catalyst 4507 switches (table) **A-4, A-5**

#### autonegotiation

Catalyst 4503-E switches (table) **1-3**

Catalyst 4506-E switches (table) **1-6**

Catalyst 4507 switches (table) **1-10, 1-14**

---

### B

#### boot process

troubleshooting **5-2**

---

### C

#### cables

ESD **2-2**

## Catalyst 4503-E switches

- chassis dimensions **A-2**
- features **1-3**
- front view **1-2**
- power requirements **2-3**
- repacking **B-1**
- specifications **A-1**

## Catalyst 4506-E switches

- attaching cable guides (figure) **3-4**
- chassis dimensions **A-3**
- features **1-6**
- front view **1-5**
- installing in racks (figure) **3-5**
- power requirements **2-3**
- repacking **B-1**
- specifications **A-2**

## Catalyst 4507 switches

- chassis dimensions **A-4, A-5**
- description **1-9, 1-13**
- features **1-10, 1-14**
- front view **1-9, 1-13**
- specifications **A-3, A-5**

## caution

## SIMM

- installation **4-22**

## chassis dimensions

- See Catalyst 4503-E switches; Catalyst 4506-E switches;
- See Catalyst 4503 switches; Catalyst 4506 switches; Catalyst 4507 switches

## checklists

- site planning **2-11**

## commands

- show port **D-8**

## components

- troubleshooting **5-4 to 5-19**

## connecting

- system ground **3-5 to 3-7**
- to console port **C-2**

## console port

- connecting to **C-2**
- description **D-4**

## conventions

- warnings **-x**

---

**D**

## DC-input power supplies

- connecting system ground **3-6**
- description **1-25**
- environmental monitoring **1-29**
- figure **1-27, 4-4**
- handling (figure) **4-11**
- installing **4-11**
- removing **4-8**
- replacing **4-11**
- See also AC-input power supplies
- troubleshooting **5-4**
- verifying operation **4-13**

## dimensions

- Catalyst 4503-E switches (table) **A-2**
- Catalyst 4506-E switches (table) **A-3**
- Catalyst 4507 switches (table) **A-4, A-5**

## disconnecting

- ground connections (warning) **4-9**

## documentation

- conventions **viii**

---

**E**

## electrostatic discharge

- see ESD

## environmental monitoring

- power supplies **1-29**

## ESD

- cabling and preventing damage **2-2**

## Ethernet management port



description **D-4**

Ethernet management ports

LEDs **5-3**

network switching not supported (note) **D-4**

troubleshooting **5-3**

---

## F

FAIL LEDs

checking **4-7**

verifying power supply status **4-13**

fan assemblies

booting **5-2**

Catalyst 4503-E switches (figure) **1-3**

Catalyst 4506-E switches (figure) **1-6**

Catalyst 4507 switches (figure) **1-10, 1-14**

description **1-24**

installing **4-14**

power supplies **1-28**

removing **4-13**

replacing **4-13**

troubleshooting **5-6**

verifying installation **4-15**

FAN OK LED

checking **4-7**

description **1-28**

Fast Ethernet

See 100BASE-T

field-replaceable units

See FRUs

Flash code

troubleshooting **5-3**

front panel components **D-3**

FRUs

AC-input power supplies **4-4 to 4-8**

DC-input power supplies **4-8 to 4-13**

fan assemblies **4-13 to 4-15**

---

## G

Gigabit Ethernet

See 1000BASE-T

See 1000BASE-X

GOOD LEDs

checking **4-7**

troubleshooting **5-4**

verifying power supply status **4-13**

grounding

connecting systems **3-6**

ground wire

figure **4-10**

---

## H

heat dissipation

description (table) **2-3**

supervisor engines **2-3**

switch chassis **2-3**

switching modules **2-3**

help

See TAC

hot swapping

fan assemblies **4-13**

status messages **D-8**

switching modules **D-8**

humidity

Catalyst 4503-E switch specifications (table) **A-1**

Catalyst 4506-E switch specifications (table) **A-2**

Catalyst 4507 switch specifications (table) **A-3, A-5**

---

## I

INPUT OK LED

description (table) **1-28**

installation

connecting to a power source **C-2**

starting the terminal-emulation software **C-2**

## installing

- AC-input power supplies **4-4 to 4-8**
- DC-input power supplies **4-8 to 4-13**
- fan assemblies **4-13 to 4-15**

installing switches in racks **3-2 to 3-7****L**

## labels, chassis serial number

See serial numbers

## LEDs

- checking power supplies **5-3**
- checking supervisor engines **5-2**
- POST results **C-3**
- See also specific types of LEDs
- switching modules **D-7**
- switch load indicators **D-3**

## Link LED

description (table) **1-22**

LINK LEDs (table) **5-8, D-7**load sharing, power supplies **1-28****M**

## MAC addresses

supported on Catalyst 4503-E switches (table) **1-17**

## management

- Ethernet **D-4**
- local, on Catalyst 4503-E switches **1-2**
- local, on Catalyst 4506-E switches **1-5**
- local, on Catalyst 4507 switches **1-9, 1-13**
- remote, on Catalyst 4503-E switches **1-2**
- remote, on Catalyst 4506-E switches **1-5**
- remote, on Catalyst 4507 switches **1-9, 1-13**

management port LED **D-3**

## Media Access Control addresses

See MAC addresses

Mux buffers **4-15, 5-7****O**

## OUTPUT FAIL LED

environmental monitoring **1-29**

**P**packaging materials **B-1**port status LEDs **5-9, D-7**

## POST

LEDs **C-3**

## power

requirements **2-3**

## power cords

See AC-input power cords

## power supplies

LEDs **5-3**

load sharing **1-28**

See AC-input power supplies; DC-input power supplies; external power supplies

preventing ESD damage **2-2****R**

## rack-mounting

switches **3-3**

Redundancy modules **4-15, 5-7**

## removing

AC-input power supplies **4-4**

DC-input power supplies **4-8**

repacking switches **B-1**

## replacing

AC-input power supplies **4-6 to 4-8**

DC-input power supplies **4-11 to 4-13**

fan assemblies **4-14**

reset switches **D-3**

**S**

- serial numbers **5-18**
- shipping instructions **B-1**
- show port command **D-8**
- show system command **4-8**
- site planning
  - checklist **2-11**
- slots
  - Catalyst 4503-E switches (figure) **1-2**
  - Catalyst 4506-E switches (figure) **1-5**
  - Catalyst 4507 switches (figure) **1-9, 1-13**
- specifications
  - Catalyst 4503-E switches (table) **A-1**
  - Catalyst 4506-E switches (table) **A-2**
  - Catalyst 4507 switches (table) **A-3, A-5**
- startup
  - troubleshooting **5-2**
- STATUS LED
  - description (table) **1-22**
- Status LEDs
  - supervisor engines **D-3**
- Supervisor Engine IV
  - front panels (figure) **1-20, 1-21**
- supervisor engines
  - Catalyst 4503-E switches **1-3**
  - Catalyst 4506-E switches **1-6**
  - Catalyst 4506 switches **1-10, 1-14**
  - console ports **D-4**
  - description **1-16**
  - LEDs (table) **1-22**
  - slot locations **1-2, 1-5, 1-9, 1-13**
  - specifications (table) **A-14**
- Supervisor Engine V-10GE
  - front panels (figure) **1-21**
- switching modules
  - Catalyst 4503-E supported **1-3**
  - Catalyst 4506-E supported **1-6**
  - Catalyst 4507R supported **1-11**

Catalyst 4510R supported **1-15**

LEDs **D-7**

switch load indicators **D-3**

**T**

## TAC

contacting **5-18**

## temperature

Catalyst 4503-E switches **A-1**

Catalyst 4506-E switches **A-2**

Catalyst 4507 switches **A-3, A-5**

terminal-emulation software **C-2**

troubleshooting **5-4**

boot process **5-2**

fan assemblies **5-6**

power supplies **5-4**

startup **5-2**

**U**

## uplink ports

description **1-22**

## UTILIZATION LEDs

description (table) **1-22**

**V**

## voltage

specifications **A-8, A-10**

**W**

## weight

Catalyst 4503-E switches (table) **A-2**

Catalyst 4506-E switches (table) **A-3**

Catalyst 4507 switches (table) **A-4, A-5**



## Free Manuals Download Website

<http://myh66.com>

<http://usermanuals.us>

<http://www.somanuals.com>

<http://www.4manuals.cc>

<http://www.manual-lib.com>

<http://www.404manual.com>

<http://www.luxmanual.com>

<http://aubethermostatmanual.com>

Golf course search by state

<http://golfingnear.com>

Email search by domain

<http://emailbydomain.com>

Auto manuals search

<http://auto.somanuals.com>

TV manuals search

<http://tv.somanuals.com>