



## **Cisco uBR7225VXR Universal Broadband Router Hardware Installation Guide**

THE SPECIFICATIONS AND INFORMATION REGARDING THE PRODUCTS IN THIS MANUAL ARE SUBJECT TO CHANGE WITHOUT NOTICE. ALL STATEMENTS, INFORMATION, AND RECOMMENDATIONS IN THIS MANUAL ARE BELIEVED TO BE ACCURATE BUT ARE PRESENTED WITHOUT WARRANTY OF ANY KIND, EXPRESS OR IMPLIED. USERS MUST TAKE FULL RESPONSIBILITY FOR THEIR APPLICATION OF ANY PRODUCTS.

**Americas Headquarters**  
Cisco Systems, Inc.  
170 West Tasman Drive  
San Jose, CA 95134-1706  
USA  
<http://www.cisco.com>  
Tel: 408 526-4000  
800 553-NETS (6387)  
Fax: 408 527-0883

Text Part Number: OL-17309-02

THE SOFTWARE LICENSE AND LIMITED WARRANTY FOR THE ACCOMPANYING PRODUCT ARE SET FORTH IN THE INFORMATION PACKET THAT SHIPPED WITH THE PRODUCT AND ARE INCORPORATED HEREIN BY THIS REFERENCE. IF YOU ARE UNABLE TO LOCATE THE SOFTWARE LICENSE OR LIMITED WARRANTY, CONTACT YOUR CISCO REPRESENTATIVE FOR A COPY.

The following information is for FCC compliance of Class A devices: This equipment has been tested and found to comply with the limits for a Class A digital device, pursuant to part 15 of the FCC rules. These limits are designed to provide reasonable protection against harmful interference when the equipment is operated in a commercial environment. This equipment generates, uses, and can radiate radio-frequency energy and, if not installed and used in accordance with the instruction manual, may cause harmful interference to radio communications. Operation of this equipment in a residential area is likely to cause harmful interference, in which case users will be required to correct the interference at their own expense.

The following information is for FCC compliance of Class B devices: The equipment described in this manual generates and may radiate radio-frequency energy. If it is not installed in accordance with Cisco's installation instructions, it may cause interference with radio and television reception. This equipment has been tested and found to comply with the limits for a Class B digital device in accordance with the specifications in part 15 of the FCC rules. These specifications are designed to provide reasonable protection against such interference in a residential installation. However, there is no guarantee that interference will not occur in a particular installation.

Modifying the equipment without Cisco's written authorization may result in the equipment no longer complying with FCC requirements for Class A or Class B digital devices. In that event, your right to use the equipment may be limited by FCC regulations, and you may be required to correct any interference to radio or television communications at your own expense.

You can determine whether your equipment is causing interference by turning it off. If the interference stops, it was probably caused by the Cisco equipment or one of its peripheral devices. If the equipment causes interference to radio or television reception, try to correct the interference by using one or more of the following measures:

- Turn the television or radio antenna until the interference stops.
- Move the equipment to one side or the other of the television or radio.
- Move the equipment farther away from the television or radio.
- Plug the equipment into an outlet that is on a different circuit from the television or radio. (That is, make certain the equipment and the television or radio are on circuits controlled by different circuit breakers or fuses.)

Modifications to this product not authorized by Cisco Systems, Inc. could void the FCC approval and negate your authority to operate the product.

The Cisco implementation of TCP header compression is an adaptation of a program developed by the University of California, Berkeley (UCB) as part of UCB's public domain version of the UNIX operating system. All rights reserved. Copyright © 1981, Regents of the University of California.

NOTWITHSTANDING ANY OTHER WARRANTY HEREIN, ALL DOCUMENT FILES AND SOFTWARE OF THESE SUPPLIERS ARE PROVIDED "AS IS" WITH ALL FAULTS. CISCO AND THE ABOVE-NAMED SUPPLIERS DISCLAIM ALL WARRANTIES, EXPRESSED OR IMPLIED, INCLUDING, WITHOUT LIMITATION, THOSE OF MERCHANTABILITY, FITNESS FOR A PARTICULAR PURPOSE AND NONINFRINGEMENT OR ARISING FROM A COURSE OF DEALING, USAGE, OR TRADE PRACTICE.

IN NO EVENT SHALL CISCO OR ITS SUPPLIERS BE LIABLE FOR ANY INDIRECT, SPECIAL, CONSEQUENTIAL, OR INCIDENTAL DAMAGES, INCLUDING, WITHOUT LIMITATION, LOST PROFITS OR LOSS OR DAMAGE TO DATA ARISING OUT OF THE USE OR INABILITY TO USE THIS MANUAL, EVEN IF CISCO OR ITS SUPPLIERS HAVE BEEN ADVISED OF THE POSSIBILITY OF SUCH DAMAGES.

Cisco and the Cisco logo are trademarks or registered trademarks of Cisco and/or its affiliates in the U.S. and other countries. To view a list of Cisco trademarks, go to this URL: [www.cisco.com/go/trademarks](http://www.cisco.com/go/trademarks). Third-party trademarks mentioned are the property of their respective owners. The use of the word partner does not imply a partnership relationship between Cisco and any other company. (1110R)

*Cisco uBR7225VXR Universal Broadband Router Hardware Installation Guide*

Copyright © 2008-2009, 2012 Cisco Systems, Inc.

All rights reserved.



## CONTENTS

Document Revision History	ix
Document Objectives	ix
Audience	x
Document Organization	x
Document Conventions	xi
Warning Definition	xii
Obtaining Documentation and Submitting a Service Request	xii

---

### CHAPTER 1

<b>Cisco uBR7225VXR Overview</b>	<b>1-1</b>
Cisco uBR7225VXR Universal Broadband Router	1-1
Cisco uBR7225VXR Router Chassis	1-3
Cisco uBR7225VXR Network Interface Overview	1-4
Card Slot and Logical Interface Numbering	1-4
MAC-Layer Address	1-5
Supported System Configurations Overview	1-6
Basic Internet Access Services	1-6
VPN Services	1-8
IP Telephony Services	1-8
Telco Return	1-9
Hardware Component Descriptions	1-10
Network Processing Engine	1-10
NPE Comparisons	1-11
Cisco Cable Interface Line Cards	1-12
Power Supplies	1-13
Fan Trays	1-14
Cisco uBR7225VXR Chassis	1-17
Subchassis and Midplane	1-17
Cisco uBR7225VXR Subchassis	1-17
CompactFlash Disk	1-18

---

### CHAPTER 2

<b>Preparing the Cisco uBR7225VXR Router for Installation</b>	<b>2-1</b>
Safety Recommendations	2-1
Lifting the Cisco uBR7225VXR Router Safely	2-2
Safety with Electricity	2-3

- Preventing Electrostatic Discharge Damage 2-4
- Site Requirements 2-5
  - AC Power 2-5
  - Site Environment 2-5
  - Site Configuration: Maintaining Normal Operation 2-6
  - General Precautions 2-6
  - Power Considerations 2-7
- Required Network Information 2-7
  - Before You Begin 2-7
- Installation Tools 2-8
- Rack-Mount and Cable-Management Kit 2-8
- Equipment Required to Verify Your Plant's RF Setup 2-9
- Shipping Container Contents 2-9
  - Verifying the Shipping Container Contents 2-9
- Provisioning the Cable Headend 2-10
  - Two-Way Data and VoIP 2-10
  - Headend Certification 2-11
  - Diplex Filters 2-11
  - Receivers 2-11
  - DHCP, DNS, TFTP, and TD Servers 2-12
  - Telco Return 2-12
    - Dial-Up/Remote Access Servers 2-12
    - RADIUS Dial Security Servers 2-12
  - Authentication, Authorization, and Accounting Servers 2-13
  - VoIP Gateways and Gatekeepers 2-13
  - VoIP SGCP Pass-Through 2-13
  - Headend Wiring 2-14
    - Interference Considerations 2-14
    - Distance Limitations and Interface Specifications 2-14
  - Equipment Racks 2-15
- Site Preparation Checklist 2-17
- Component Checklists 2-18

**CHAPTER 3**

- Installing the Cisco uBR7225VXR Router 3-1**
  - Cisco uBR7225VXR Router Installation Checklist 3-1
  - Cisco uBR7225VXR Router Chassis Rack-Mounting Options 3-2
    - Cable-Management Bracket Requirements 3-5
  - Installing the Brackets on the Chassis 3-7

Installing Rack-Mount Brackets on the Rear of the Chassis	3-7
Installing Rack-Mount Brackets on the Front of the Chassis	3-8
Installing Rack-Mount Brackets in the Middle of the Chassis	3-9
Installing the Chassis in the Rack	3-10
Installing the Chassis in a Workbench or Tabletop Environment	3-12
Installing the Cable-Management Bracket on a Cisco uBR7225VXR Router in a Workbench or Tabletop Environment	3-13
Cabling	3-13
Connecting Cable Interface Line Card Cables	3-14
Console and Auxiliary Port Connection Equipment	3-14
Console Port Signals	3-15
Auxiliary Port Signals	3-15
Protective Grounding	3-16
Connecting Power	3-16
Connecting to the AC-Input Power Supply	3-17
Powering On the Cisco uBR7225VXR Router	3-18
Configuring the Interfaces	3-19

**CHAPTER 4****Connecting the Cisco uBR7225VXR Router to the Cable Headend 4-1**

Two-Way Data Headend Architecture	4-2
One-Way Data Headend Architecture	4-3
RF and Digital Data Overview	4-3
Connecting and Configuring the Downstream	4-4
Installing and Configuring the Upconverter	4-4
Measuring the Downstream RF Signal	4-4
Measuring the Downstream RF Signal Using the Channel Power Option on a Spectrum Analyzer	4-5
Measuring the Downstream IF Signal at the Cisco uBR7225VXR Router	4-5
Measuring the Downstream RF Signal at the Upconverter Output	4-7
Measuring the Downstream RF Signal Using CATV Mode on a Spectrum Analyzer	4-11
Measuring the Downstream IF Signal at the Cisco uBR7225VXR Router Using CATV Mode	4-11
Measuring the Downstream RF Signal at the Upconverter Output Using CATV Mode	4-14
Connecting and Configuring the Upstream	4-18
Connecting the Upstream to the Optical Receiver	4-18
Testing the Upstream Configuration	4-19
Measuring the Upstream RF Signal	4-22
Measuring the Upstream RF Signal Using a Spectrum Analyzer	4-22
Analyzing the Upstream RF Signal	4-25
Using the Zero-Span Method with Adjacent Upstream Channels	4-28

Measuring the RF Signal at the Forward Test Point on a Laser Transmitter 4-37  
 Configuring the Digital Signal 4-40

**CHAPTER 5**

**Maintaining the Cisco uBR7225VXR Router 5-1**

Online Insertion and Removal 5-1  
 Environmental Monitoring and Reporting Functions 5-2  
     Environmental Monitoring 5-2  
     Reporting Functions 5-3  
     Fan Failures 5-6

**CHAPTER 6**

**Troubleshooting 6-1**

Overview 6-1  
     Providing Information 6-1  
 Problem Solving with Subsystems 6-2  
     Identifying Startup Problems 6-3  
 Power Subsystem 6-4  
 Cooling Subsystem 6-4  
 Processor Subsystem 6-5  
     Troubleshooting the Network Processing Engine 6-5  
     Troubleshooting Cable Interface Line Cards 6-6  
     Other Troubleshooting Information Websites 6-7  
 Verifying the Downstream Signal 6-7

**APPENDIX A**

**Cisco uBR7225VXR Router Specifications A-1**

Cisco uBR7225VXR Physical and System Specifications A-1

**APPENDIX B**

**RF Specifications B-1**

DOCSIS 1.0 Transmission Characteristics B-2  
     Downstream RF Channel Transmission Characteristics B-2  
     Upstream RF Channel Transmission Characteristics B-3  
 DOCSIS 1.1 Transmission Characteristics B-4  
     Downstream RF Channel Transmission Characteristics B-4  
     Upstream RF Channel Transmission Characteristics B-5  
 EuroDOCSIS Transmission Characteristics B-5  
     Downstream RF Channel Transmission Characteristics B-6  
     Upstream RF Channel Transmission Characteristics B-7  
 Electrical Input and Output B-8

**APPENDIX C****Cable Specifications C-1**

- Coaxial Cables C-1
- Console and Auxiliary Port Cables and Pinouts C-2
  - Identifying an RJ-45 Rollover Cable C-2
  - Console Port Cables and Pinouts C-3
  - Auxiliary Port Cables and Pinouts C-4
- Fast Ethernet Port Cables and Pinouts C-4
  - Identifying an RJ-45 Crossover Cable C-4
  - Identifying an RJ-45 Straight-Through Cable C-5
- Fiber-Optic Cables and Connectors C-6

**APPENDIX D****Industry-Standard Wiring Plans D-1**

- About Wiring Standards D-1
  - TIA/EIA Standards Information D-2
- Optical Fiber Color Codes D-2
- Telephone Wire Color Codes D-3

**APPENDIX E****Frequency Allocation Tables E-1**

- Standards Comparisons E-2
- NTSC Cable Television Channels and Relative Frequencies E-3
- NTSC (M) Cable Television Frequencies for Japan E-8
- PAL/SECAM Cable Television Channels and Relative Frequencies E-10

**APPENDIX F****Manufacturers for Headend Provisioning Requirements F-1**

- North American Channel Plans F-1
- European Channel Plans F-3

**APPENDIX G****Site Log G-1****GLOSSARY****INDEX**







## Preface

---

This preface describes the objectives, intended audience, and organization of this document and explains how to find additional information on related products and services.

This preface contains the following sections:

- [Document Revision History, page ix](#)
- [Document Objectives, page ix](#)
- [Audience, page x](#)
- [Document Organization, page x](#)
- [Document Conventions, page xi](#)
- [Obtaining Documentation and Submitting a Service Request, page xii](#)

## Document Revision History

The Document Revision History table below records technical changes to this document.

Revision	Date	Change Summary
OL-17309-01	December 15, 2008	Original publication.
OL-17309-02	August 2012	Added information about the new 540 W AC-input power supply.

## Document Objectives

This guide provides hardware installation instructions for the Cisco uBR7225VXR universal broadband router.

The guide contains procedures to unpack, install, and connect the Cisco uBR7225VXR router hardware that enables your cable television (CATV) headend or distribution hub to support digital data and Voice-over-IP (VoIP) services. The guide includes procedures to characterize your cable plant to ensure that data services are reliably supported over the cable infrastructure.

# Audience

This guide is intended for cable system installers and technicians who physically install and connect the Cisco uBR7225VXR universal broadband router and associated equipment at the cable headend or distribution hub. Cable system installers and technicians should be familiar with their cable plant base operating parameters and service offerings.

The guide provides limited configuration information. After following applicable procedures in this guide, refer to the [“Obtaining Documentation and Submitting a Service Request”](#) section on page xii for related Cisco publications that more completely address configuration.



## Warning

**Only trained and qualified personnel should be allowed to install, replace, or service this equipment.**  
Statement 1030

# Document Organization

This hardware installation guide is organized into the following chapters and appendixes:

Chapter Title	Description
<a href="#">Chapter 1, “Cisco uBR7225VXR Overview”</a>	About Cisco uBR7225VXR chassis and components.
<a href="#">Chapter 2, “Preparing the Cisco uBR7225VXR Router for Installation”</a>	Safety considerations, tools, and other equipment required to prepare your site.
<a href="#">Chapter 3, “Installing the Cisco uBR7225VXR Router”</a>	Installing the chassis and connecting the power and network interface cables.
<a href="#">Chapter 4, “Connecting the Cisco uBR7225VXR Router to the Cable Headend”</a>	Connecting the Cisco uBR7225VXR router to a hybrid fiber-coaxial (HFC) network and configuring and measuring downstream and upstream portions of the HFC network.
<a href="#">Chapter 5, “Maintaining the Cisco uBR7225VXR Router”</a>	Basic hardware maintenance instructions.
<a href="#">Chapter 6, “Troubleshooting”</a>	Troubleshooting hardware installations.
<a href="#">Appendix A, “Cisco uBR7225VXR Router Specifications”</a>	System specifications.
<a href="#">Appendix B, “RF Specifications”</a>	Recommended RF settings at the headend for both Data-over-Cable Service Interface Specifications (DOCSIS) and EuroDOCSIS networks.
<a href="#">Appendix C, “Cable Specifications”</a>	Cable and cable pinout information for the Cisco uBR7225VXR router.
<a href="#">Appendix D, “Industry-Standard Wiring Plans”</a>	The telephone industry color-code schemes for 25-pair wires including the pin numbers, optical fibers, and small wire pairs.
<a href="#">Appendix E, “Frequency Allocation Tables”</a>	Information on the National Television System Committee (NTSC) frequency map for 6-MHz channel bands and the Phase Alternating Line (PAL) and SEquential Couleur Avec Memoire (SECAM) frequency map for 8-MHz channel bands.

Appendix F, “Manufacturers for Headend Provisioning Requirements”	Manufacturers and websites required to prepare and provision a North American or a European cable headend to support digital data.
Appendix G, “Site Log”	Example of a cable headend site log—Use to keep a historical record of actions relevant to the Cisco uBR7225VXR router installation, operations, and maintenance.

## Document Conventions

This publication uses the following conventions:

- The symbol ^ represents the key labeled *Control*. For example, the key combination ^z means hold down the Control key while you press the z key.

Command descriptions use these conventions:

- Examples that contain system prompts denote interactive sessions, indicating the commands that you should enter at the prompt. The system prompt indicates the current level of the EXEC command interpreter. For example, the prompt `Router>` indicates that you should be at the *user* level, and the prompt `Router#` indicates that you should be at the *privileged* level.

Access to the privileged level usually requires a password. For additional information, refer to the related software configuration and reference documentation listed in the *Cisco uBR7200 Series Software Configuration Guide* at the following URL:

<http://www.cisco.com/en/US/docs/cable/cmts/ubr7200/configuration/guide/cr72scg.html>

- Commands and keywords are in **boldface** font.
- Arguments for which you supply values are in *italic* font.
- Elements in square brackets ( [ ] ) are optional.
- Alternative but required keywords are grouped in braces ( { } ) and separated by vertical bars ( | ).

Examples use these conventions:

- Terminal sessions and sample console screen displays are in `screen` font.
- Information you enter is in **boldface screen** font.
- Nonprinting characters, such as passwords, are in angle brackets (< >).
- Default responses to system prompts are in square brackets ( [ ] ).
- Exclamation points (!) at the beginning of a line indicate a comment line.



### Caution

Means *reader be careful*. You are capable of doing something that might result in equipment damage or loss of data.



### Note

Means *reader take note*. Notes contain helpful suggestions or references to materials not contained in this manual.

**Timesaver**


---

Means *the described action saves time*. You can save time by performing the action described in the paragraph.

---

**Tip**


---

Means *the following information might help you solve a problem*.

---

For all warning translations, refer to the *Regulatory Compliance and Safety Information for Cisco uBR7200 Series Universal Broadband Routers* at the following URL:

<http://www.cisco.com/en/US/docs/cable/cmts/ubr7200/regulatory/compliance/ub72rcsi.html>

## Warning Definition

**Warning**


---

### IMPORTANT SAFETY INSTRUCTIONS

**This warning symbol means danger. You are in a situation that could cause bodily injury. Before you work on any equipment, be aware of the hazards involved with electrical circuitry and be familiar with standard practices for preventing accidents. Use the statement number provided at the end of each warning to locate its translation in the translated safety warnings that accompanied this device.**  
Statement 1071

### SAVE THESE INSTRUCTIONS

---

## Obtaining Documentation and Submitting a Service Request

For information on obtaining documentation, submitting a service request, and gathering additional information, see the monthly *What's New in Cisco Product Documentation*, which also lists all new and revised Cisco technical documentation, at:

<http://www.cisco.com/en/US/docs/general/whatsnew/whatsnew.html>

Subscribe to the *What's New in Cisco Product Documentation* as a Really Simple Syndication (RSS) feed and set content to be delivered directly to your desktop using a reader application. The RSS feeds are a free service and Cisco currently supports RSS version 2.0.



# CHAPTER 1

## Cisco uBR7225VXR Overview

---

This chapter describes the Cisco uBR7225VXR universal broadband router and contains the following sections:

- [Cisco uBR7225VXR Universal Broadband Router, page 1-1](#)
- [Cisco uBR7225VXR Network Interface Overview, page 1-4](#)
- [Supported System Configurations Overview, page 1-6](#)
- [Hardware Component Descriptions, page 1-10](#)

## Cisco uBR7225VXR Universal Broadband Router

The Cisco uBR7200 series universal broadband routers, part of the Cisco Cable Modem Termination System (CMTS) solution, allows high-speed data services to be packaged similar to basic cable television service or video fare.

The router is based on Data-over-Cable Service Interface Specifications (DOCSIS) and supports data and packetized voice connectivity over a bidirectional cable television and IP backbone network. The Cisco uBR7200 series universal broadband routers typically concentrates traffic from DOCSIS- or EuroDOCSIS-based cable interfaces and cable modems (or set-top boxes with integrated DOCSIS or EuroDOCSIS cable modems) on the cable television network and presents that traffic to local and remote IP hosts. For cable plants not fully upgraded to support two-way cable transmission, the router works in conjunction with dial-up access products to support upstream traffic from DOCSIS-based cable interfaces connected to the Public Switched Telephone Network (PSTN). The router supports both 6-MHz North American channel plans using ITU-T J.83 Annex B operation and 8-MHz Phase Alternating Line (PAL) and SEquential Couleur Avec Memoire (SECAM) channel plans using ITU-T J.83 Annex A operation.

The Cisco uBR7200 series universal broadband routers contains some or all of the following:

- Cable interface line cards that interface to the cable television network. The Cisco uBR7225VXR card set includes varying upstream-to-downstream interface ratios with differing bandwidth and modulation schemes supported, as well as the capability to dynamically perform complex spectrum management and operate in a 6-MHz or 8-MHz channel width environment. See the [“Cisco Cable Interface Line Cards” section on page 1-12](#).
- One network processing engine (NPE) that performs system management functions for the chassis. See the [“Network Processing Engine” section on page 1-10](#).
- The Cisco uBR7225VXR router supports an optional redundant power supply. See the [“Power Supplies” section on page 1-13](#).

- A midplane that serves as the interconnect between the cable interface line cards and the other components of the system. See the “Subchassis and Midplane” section on page 1-17.
- A fan tray, enclosing internal fans that draw cooling air into the chassis to maintain an acceptable operating temperature. See the “Fan Trays” section on page 1-14.

The cable interface cards, NPE, and power supplies slide into their respective chassis slots and connect directly to the router midplane. There are no internal cables to connect. The midplane distributes power from the power supplies to the cable interface cards, fan tray, and NPE.

The Cisco uBR7225VXR universal broadband router may be installed on a tabletop or rack-mounted. A rack-mount kit ships with each router. The rack-mount kit includes the hardware needed to mount the router in a standard 19-inch equipment rack or telco-type rack.

The Cisco uBR7200 series universal broadband routers supports:

- Environmental monitoring and reporting functions to resolve adverse environmental conditions before loss of operation.
- Online insertion and removal (OIR), allowing key system components to be added or removed without powering off the chassis.




---

**Caution**

You can remove and replace a cable interface line card with the same type of component without interrupting the rest of the system or having to reconfigure the system. However, to replace a cable interface line card with a different type of card (for example, hot swapping from a Cisco uBR-MC16U cable interface line card to a Cisco uBR-MC28U cable interface line card), you must copy your startup configuration to your running configuration on the Cisco uBR7225VXR router to enable the interfaces on the new cable interface line card.

---




---

**Caution**

The NPE does not support OIR. You must power down the chassis before removing the NPE.

---




---

**Note**

For specific instructions to install, remove, or replace system components, refer to the documentation at the following URL:

[http://www.cisco.com/en/US/products/hw/cable/ps2217/tsd\\_products\\_support\\_series\\_home.html](http://www.cisco.com/en/US/products/hw/cable/ps2217/tsd_products_support_series_home.html)

---

# Cisco uBR7225VXR Router Chassis

The Cisco uBR7225VXR router chassis has:

- Two slots for cable interface cards
- One slot for a network processing engine

The front of the Cisco uBR7225VXR chassis provides access to two cable interface line cards. See [Figure 1-1](#).

The rear of the Cisco uBR7225VXR provides access to the network processing engine and up to two power supplies. See [Figure 1-2](#).

A fully configured Cisco uBR7225VXR router can operate with only one installed power supply; however, a second, optional power supply of the same type provides hot-swappable, load-sharing, and redundant power. In a chassis using two power supplies, if one power supply fails or is removed, the redundant power supply immediately takes over the router’s power requirements and maintains normal operation without interruption.

The power supply has the router’s main power switch and an AC-input power receptacle. Mounting holes for a ground lug are located on the far right side on the rear of the chassis, to provide a chassis ground connection for ESD-preventive equipment. See [Figure 3-13 on page 3-16](#).



**Note**

[Figure 1-2](#) shows the rear of a Cisco uBR7225VXR router configured with two 300W AC-input power supplies.

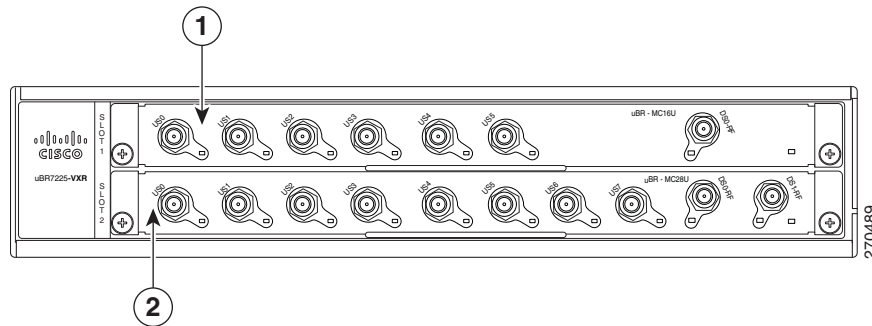


**Caution**

If you are using two power supplies, make sure that each one is plugged into a separate branch circuit.

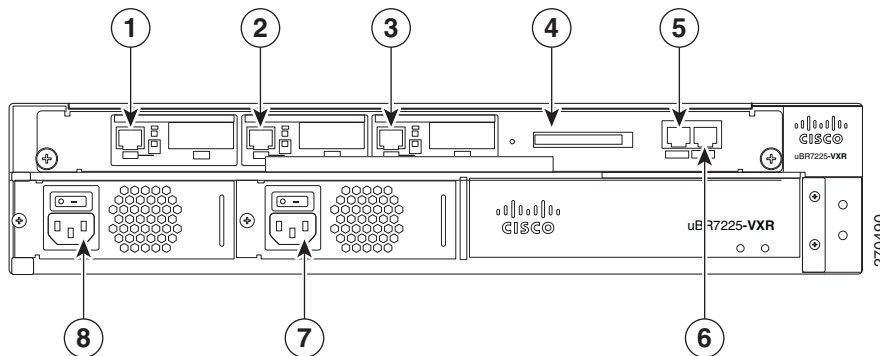
A fully loaded router, with two installed power supplies (300 W) and all chassis slots filled, weighs approximately 48 pounds (21.8 kg). For clearance requirements and rack-mount installation considerations, refer to the “[Site Environment](#)” section on [page 2-5](#).

**Figure 1-1 Cisco uBR7225VXR Router—Front View**



<b>1</b>	Cable interface line card slot 1	<b>2</b>	Cable interface line card slot 2
----------	----------------------------------	----------	----------------------------------

Figure 1-2 Cisco uBR7225VXR Router—Rear View



1	Gigabit Ethernet 0/1	5	Console port
2	Gigabit Ethernet 0/2	6	Auxiliary port
3	Gigabit Ethernet 0/3	7	AC-input power supply 2
4	CompactFlash Disk slot	8	AC-input power supply 1

## Cisco uBR7225VXR Network Interface Overview

This section provides a functional overview of the network interfaces available on the Cisco uBR7225VXR universal broadband router, cable interface line card slot and logical interface numbering, as well as the MAC address assignments for cable interface line card interfaces.

### Card Slot and Logical Interface Numbering

In the Cisco uBR7200 series universal broadband routers, the *slot number* is the chassis slot in which a cable interface card is installed.

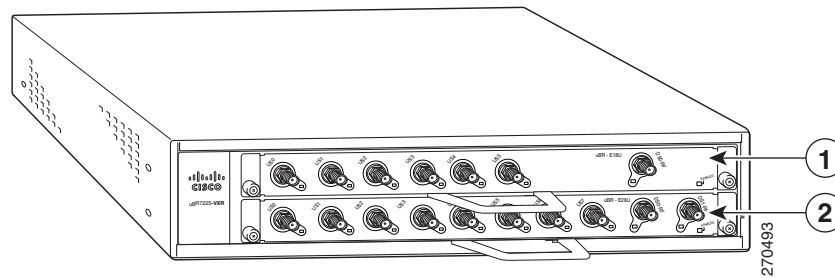
Cable interface line card slots maintain the same slot number regardless of whether other cable interface line cards are installed or removed. However, when you move a cable interface line card to a different slot, the logical interface number changes to reflect the new slot number.

The MAC-layer or hardware address is a standardized data-link layer address that is required for certain network interface types. These addresses are specific and unique to each port. The Cisco uBR7225VXR uses a specific method to assign and control the MAC-layer addresses of its port adapters. For a description of the MAC-layer address, refer to the [“MAC-Layer Address”](#) section on page 1-5.

The two cable interface line cards in the Cisco uBR7225VXR router provide the connection between the router's two PCI buses (mb1 and mb2) and external networks. See [Figure 1-3](#).



**Figure 1-3 Cisco uBR7225VXR Chassis and Cable Interface Line Cards**



<b>1</b>	Cable interface line card slot 1	<b>2</b>	Cable interface line card slot 2
----------	----------------------------------	----------	----------------------------------

## MAC-Layer Address

All LAN interfaces (ports) require unique MAC-layer addresses, also known as *hardware* addresses. Typically, the MAC address of an interface is stored on a memory component that resides directly on the interface circuitry; however, the OIR feature requires a different method. For a description of OIR, refer to the “[Online Insertion and Removal](#)” section on page 5-1.

The OIR feature allows you to remove a cable interface line card and replace it with another identically configured one. If the new cable interface line card matches the cable interface line card you removed, the system immediately brings it online. In order to allow OIR, an address allocator with a unique MAC address is stored in EPROM on the Cisco uBR7225VXR universal broadband router midplane. Each address is reserved for a specific slot in the router regardless of whether a cable interface line card resides in that slot.

The MAC addresses are assigned to the slots in sequence. This address scheme allows you to remove cable interface cards and insert them into other universal broadband routers without causing the MAC addresses to move around the network or be assigned to multiple devices.



### Note

Storing the MAC addresses for every slot in one central location means that the addresses stay with the memory device on which they are stored.

For information on the commands used to configure your Cisco uBR7225VXR router, refer to the *Cisco IOS Configuration Fundamentals Configuration Guide* at the following URL:

[http://www.cisco.com/en/US/docs/ios/fundamentals/configuration/guide/12\\_4/cf\\_12\\_4\\_book.html](http://www.cisco.com/en/US/docs/ios/fundamentals/configuration/guide/12_4/cf_12_4_book.html)

Also refer to the *Cisco IOS Configuration Fundamentals Command Reference* at the following URL:

[http://www.cisco.com/en/US/docs/ios/fundamentals/command/reference/cf\\_book.html](http://www.cisco.com/en/US/docs/ios/fundamentals/command/reference/cf_book.html)

# Supported System Configurations Overview

The Cisco uBR7200 series universal broadband routers is installed at a cable television headend or a distribution hub. Related networking and RF equipment, servers, and other host computers are installed, along with the Cisco uBR7225VXR router, to support digital data transmission.

To deliver data and VoIP services over the cable television system, TV channels are allocated to carry digital data. Data is modulated downstream on:

- 6-MHz channels in the 88 to 860 MHz range, using North American channel plans through Cisco cable interface line cards installed in the chassis. For bidirectional cable plants, a portion of the 5 to 42 MHz range is used for upstream data transmission. For one-way cable plants or cable segments yet to be upgraded, DOCSIS-based cable interfaces configured for telco return are also supported.
- 8-MHz channels in the 108 to 862 MHz range using PAL/SECAM channel plans through Cisco cable interface line cards installed in the chassis. For bidirectional cable plants, a portion of the spectrum in the 5 to 65 MHz range is used for upstream data transmission.
- 6-MHz channels in the 70 to 860 MHz range, using J-DOCSIS channel operation (extensions for Japan and select regions) through Cisco cable interface line cards installed in the chassis. For bidirectional cable plants, a portion of the 5 to 55 MHz range is used for upstream data transmission.

The following sections illustrate the supported configurations including:

- Basic Internet access services
- Virtual private network (VPN) services
- IP telephony services
- Telco return

## Basic Internet Access Services

A Cisco uBR7225VXR universal broadband router is installed at the headend or distribution hub. The Cisco uBR7225VXR downstream cable interface line cards, with onboard upconverter, translate the downstream signals to RF for broadcast. The Cisco uBR7225VXR router enables you to transmit downstream data in both the 6-MHz North American or Japanese and the 8-MHz European channel environments using the appropriate model of the cable interface line card.

Receivers, scramblers, and descramblers process the television signals to encode or decode signals as needed for broadcast. Modulators format the analog television and digital signals while upconverters change the carrier frequency of a modulated signal to a specified frequency. The analog TV channels and digitally modulated carriers then pass through the RF combiner.

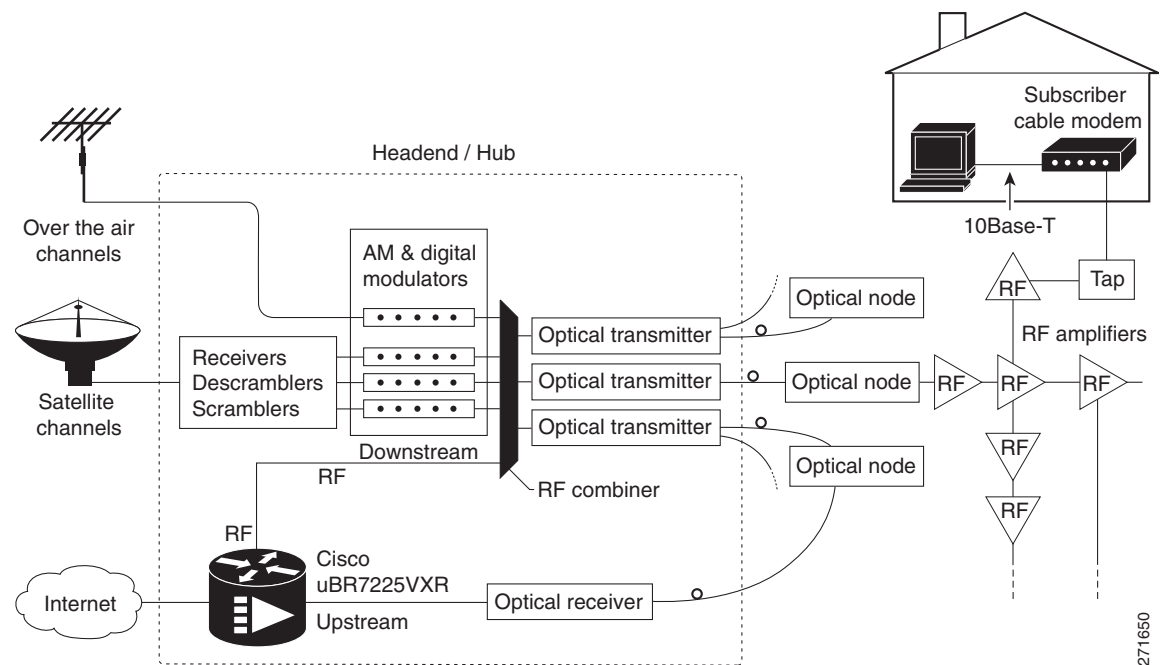
The signals are broadcast from the headend through optical transmitters typically to fiber nodes in the network. Amplifiers, coaxial cable, and taps carry the signals to the subscriber premises. Signals are processed as follows:

- Set-top boxes (STBs), televisions, or VCRs receive analog and digital data signals.
- DOCSIS-based cable interfaces and STBs connected to customer premises equipment (CPE) receive digital data signals:
  - Two-way cable interfaces transmit RF signals back through amplifiers to optical fiber receivers at the headend. These receivers pass the upstream signal to the upstream ports on the Cisco uBR7225VXR router for processing.

- Telco return cable interfaces transmit over the PSTN. Dial-up servers and other equipment handle the upstream traffic and pass appropriate data to the Cisco uBR7225VXR routers. For telco return specifics, refer to the “Telco Return” section on page 1-9.

Figure 1-4 shows the architecture of a typical two-way hybrid fiber-coaxial (HFC) network, equipped to support two-way data communication.

**Figure 1-4 Two-Way HFC Cable Network Example**



Cisco provides a configuration tool—Cisco Network Registrar (CNR)—which is optimized for high performance automatic dynamic IP address allocation to cable interfaces, PCs, and other devices on the broadband network. Cisco also provides an integrated suite of configuration tools, including CNR, for relatively large cable networks called Cisco Subscriber Registration Center (CSRC). CSRC allows large-scale configuration and management of broadband modems. Leveraging the extensibility of CNR, CSRC enables and administers subscriber self-registration. The directory-enabled architecture of CSRC allows it to integrate with Lightweight Directory Access Protocol (LDAP) version 3 directory servers.

For more information on CSRC and CNR involvement in the cable network, refer to the CSRC and CNR documentation.

*Cisco Network Registrar Install and Upgrade Guide* at the following URL:

[http://www.cisco.com/en/US/products/sw/netmgtsw/ps1982/prod\\_installation\\_guides\\_list.html](http://www.cisco.com/en/US/products/sw/netmgtsw/ps1982/prod_installation_guides_list.html)

*Cisco Subscriber Registration Centre Installation Guide* at the following URL:

[http://www.cisco.com/en/US/products/sw/netmgtsw/ps2181/products\\_installation\\_guide\\_chapter09186a0080086f1a.html](http://www.cisco.com/en/US/products/sw/netmgtsw/ps2181/products_installation_guide_chapter09186a0080086f1a.html)

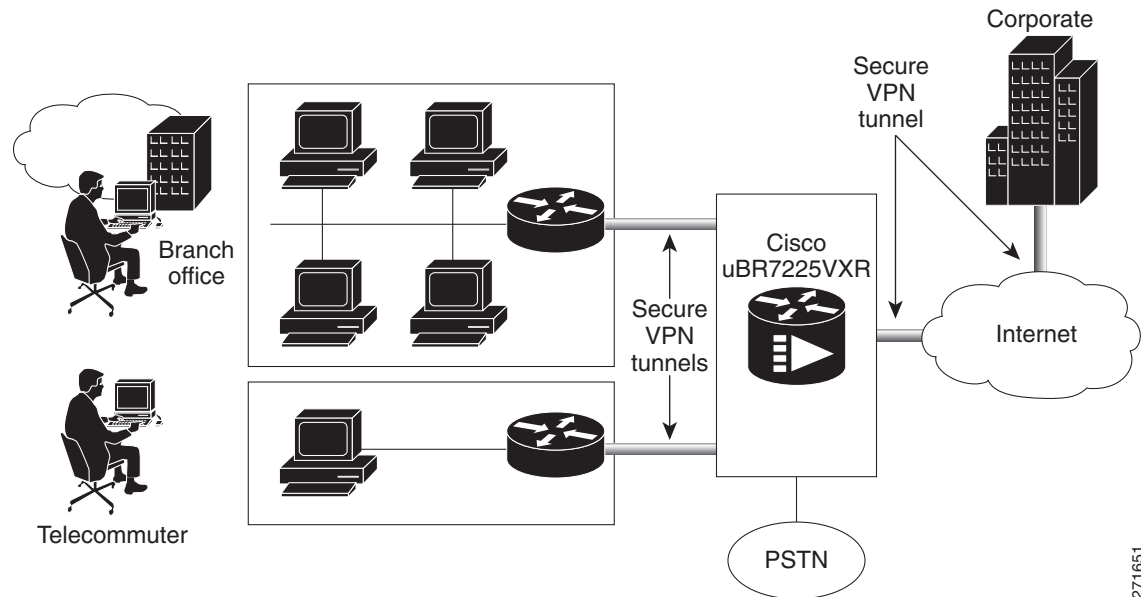
Also refer to the *Cisco uBR7200 Series Software Configuration Guide* at the following URL:

<http://www.cisco.com/en/US/docs/cable/cmts/ubr7200/configuration/guide/cr72scg.html>

## VPN Services

The Cisco uBR7225VXR router supports VPN services. Figure 1-5 shows a typical VPN architecture. VPNs can be initiated at a cable modem residing at a subscriber site or can be initiated by the CMTS at the headend or distribution hub depending upon your particular Cisco IOS software image.

Figure 1-5 Two-Way VPN Network Example



### Note

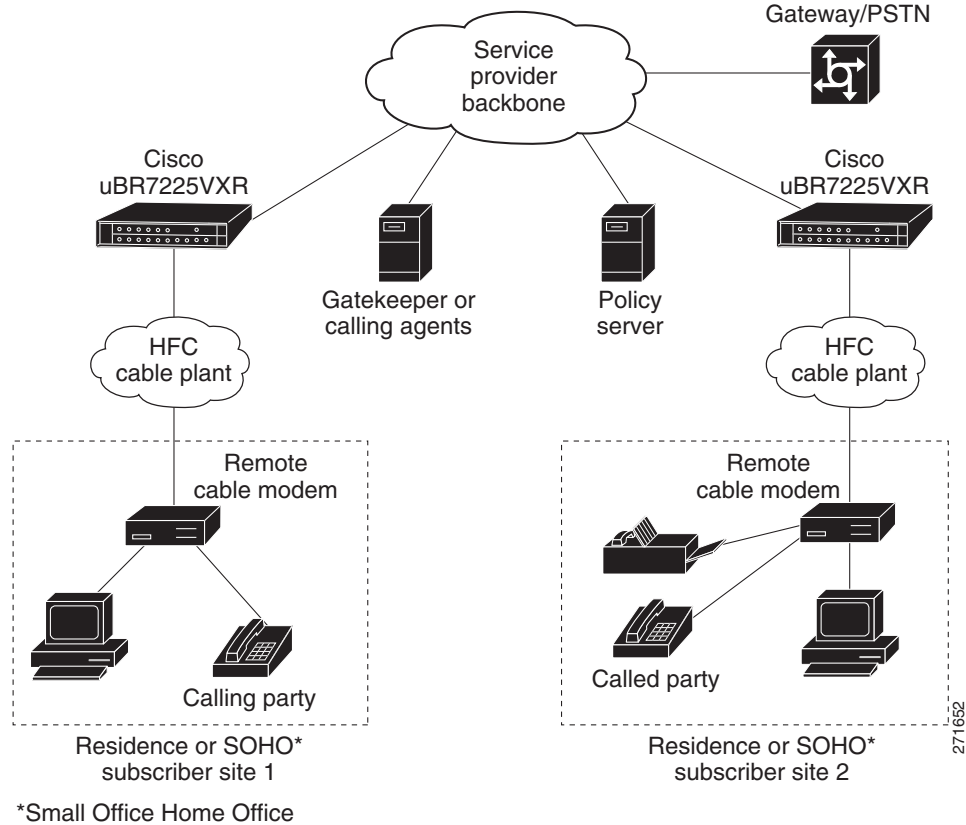
Many VPN architectures involve the use of encryption and decryption. Encryption and decryption are subject to export licensing controls. For more information, refer to *Regulatory Compliance and Safety Information for Cisco uBR7200 Series Universal Broadband Routers*, at the following URL:

<http://www.cisco.com/en/US/docs/cable/cmts/ubr7200/regulatory/compliance/ub72rcsi.html>

## IP Telephony Services

The Cisco uBR7225VXR router supports the transmission of packetized voice and facsimile traffic over the cable and IP backbone network. Figure 1-6 on page 1-9 shows a typical two-way configuration involving Voice-over-IP (VoIP) telephony services.

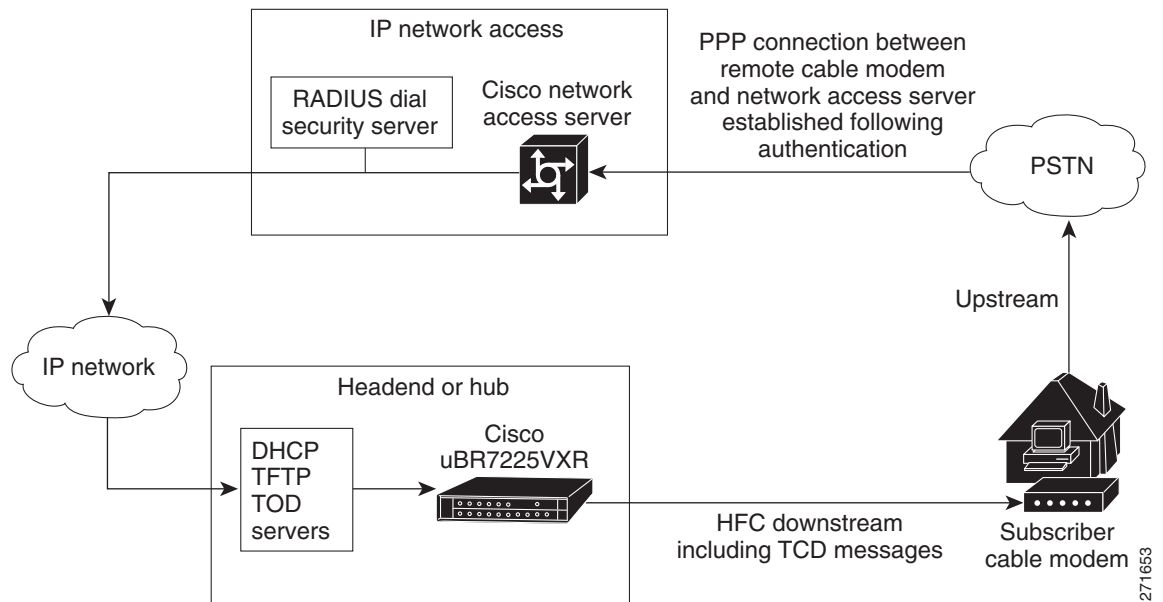
Figure 1-6 Two-Way IP Telephony Network Example



## Telco Return

In telco return configurations, the Cisco uBR7225VXR universal broadband router provides downstream data flow from cable interface line cards connected to the cable system and accepts upstream traffic via a combination of the local PSTN and IP network path that terminates at the Cisco uBR7225VXR router. Upstream data transmission takes place over a telephone modem (external or internal to a cable interface), as well as a cable interface line card in a PC, based on the third-party cable interface vendor) connected to an analog telephone line. [Figure 1-7 on page 1-10](#) illustrates a telco return configuration.

Figure 1-7 Telco Return Network Example



## Hardware Component Descriptions

Most Cisco uBR7225VXR universal broadband router components are field-replaceable units (FRUs). These units, unless otherwise noted, are OIR compatible. See the “[Online Insertion and Removal](#)” section on page 5-1

FRU documentation (instructions on installing, removing, and replacing) is located at the following URL:

[http://www.cisco.com/en/US/products/hw/routers/ps341/prod\\_installation\\_guides\\_list.html](http://www.cisco.com/en/US/products/hw/routers/ps341/prod_installation_guides_list.html)

The following components are described:

- [Network Processing Engine](#), page 1-10
- [Cisco Cable Interface Line Cards](#), page 1-12
- [Power Supplies](#), page 1-13
- [Fan Trays](#), page 1-14
- [Cisco uBR7225VXR Chassis](#), page 1-17
- [Subchassis and Midplane](#), page 1-17
- [CompactFlash Disk](#), page 1-18

## Network Processing Engine

The network processing engine (NPE) maintains and executes the system management functions for the Cisco uBR7225VXR router. The network processing engine performs the following system management functions:

- Sending and receiving routing protocol updates
- Managing tables, caches, and buffers
- Monitoring interface and environmental status
- Providing Simple Network Management Protocol (SNMP) management and console/Telnet interface
- Accounting and switching of data traffic
- Booting and reloading images

Refer to *Network Processing Engine and Network Services Engine Installation and Configuration*, for specifications, and removal and replacement instructions for these components. View the document online at the following URL:

[http://www.cisco.com/en/US/docs/routers/7200/install\\_and\\_upgrade/network\\_process\\_engine\\_install\\_config/npense.html](http://www.cisco.com/en/US/docs/routers/7200/install_and_upgrade/network_process_engine_install_config/npense.html)

A CPU reset button is located on the NPEs' faceplate. The CPU reset button resets the entire system.



#### Caution

To prevent system errors and problems, use the CPU reset button only at the direction of your service representative.

## NPE Comparisons

The network processing engines used in the Cisco uBR7225VXR router are the Cisco uBR7200-NPE-G1 and Cisco uBR7200-NPE-G2.



#### Note

The Cisco uBR7200-NPE-G1 should use the boothelper image `ubr7200-kboot-mz.122-33.SCA.bin` available from Cisco IOS Release 12.3(33)SCA and later. The Cisco uBR7200-NPE-G2 should use the boothelper image `ubr7200p-boot-mz.122-33.SCA1.bin` available from Cisco IOS Release 12.3(33)SCB and later.

NPE components:

- Reduced instruction set computing (RISC) microprocessor:
  - Cisco uBR7200-NPE-G1 with a 700-MHz Broadcom BCM1250 processor
  - Cisco uBR7200-NPE-G2 with a 1.67-GHz Motorola Freescale MPC7448 processor
- System controller:
  - Cisco uBR7200-NPE-G1 and Cisco uBR7200-NPE-G2 do not require an I/O controller.
- Upgradable memory modules:
  - Cisco uBR7200-NPE-G1—SDRAM: 256 MB (default), 512 MB, and 1 GB. There are two DRAM memory slots, so 256 MB of memory consists of two 128-MB memory SODIMMs, 512 MB consists of two 256-MB memory SODIMMs, and 1 GB consists of two 512-MB memory SODIMMs. It is necessary to have the same size SODIMM in each memory bank on an NPE-G1. The type of DRAM memory being used on the NPE-G1 is double data-rate (DDR) memory. DDR memory provides high-performance memory access rates.

- Cisco uBR7200-NPE-G2—SDRAM: 1 GB (default) and 2 GB. There are two DRAM memory slots, so 1 GB of memory consists of two 512-MB memory SODIMMs, and 2 GB consists of two 1 GB memory SODIMMs. It is necessary to have the same size SODIMM in each memory bank on an NPE-G2. The type of DRAM memory being used on the NPE-G2 is double data-rate (DDR) memory. DDR memory provides high-performance memory access rates.
- Cache memory:
  - Cisco uBR7200-NPE-G1—16-MB packet memory on 256-MB SDRAM, and 32-MB packet memory on 512-MB and 1-GB SDRAM.
  - Cisco uBR7200-NPE-G2—32-MB packet memory on 512-MB and 1-GB SDRAM.
- Two environmental sensors for monitoring the cooling air as it leaves the chassis.
- Boot ROM for storing sufficient code for booting the Cisco IOS software.

For memory replacement instructions, refer to the *Memory Replacement Instructions for the Network Processing Engine or Network Services Engine and Input/Output Controller* document at the following URL:

[http://www.cisco.com/en/US/docs/routers/7200/install\\_and\\_upgrade/npe-nse\\_memory\\_install/memory.html](http://www.cisco.com/en/US/docs/routers/7200/install_and_upgrade/npe-nse_memory_install/memory.html)

## Cisco Cable Interface Line Cards

Cisco cable interface line cards (also known as *line cards*), with internal IF-to-RF upconverters, serve as the RF interface between the cable headend and both DOCSIS-based cable modems and EuroDOCSIS-based cable modems and set-top boxes (STBs). Cisco cable interface line cards separate downstream output and upstream input cable interfaces on the Cisco uBR7225VXR router to enable downstream and upstream signal combining and splitting arrangements.

Cisco cable interface line cards can be used in both 6-MHz NTSC standard and 8-MHz PAL/SECAM channel environments.

The cable interface line cards connect directly to the universal broadband router's midplane. Cable interface line cards installed in the Cisco uBR7225VXR router support OIR.



### Caution

To ensure the proper flow of cooling air across internal components, make sure that blank cable interface line card is installed in an unoccupied chassis slot. Also make sure that power supply filler plates are installed in unoccupied power supply bays.

For more information regarding specific cable interface line cards, refer to the *Cisco uBR7200 Series Cable Interface Line Card Hardware Installation Guide*. To view the document online, go to the following URL:

[http://www.cisco.com/en/US/docs/interfaces\\_modules/cable/line\\_cards/installation/guide/mcxxfru.html](http://www.cisco.com/en/US/docs/interfaces_modules/cable/line_cards/installation/guide/mcxxfru.html)



## Power Supplies

The Cisco uBR7225VXR router is equipped with one of the following power supplies:

- 300W AC-input power supply—The maximum AC-input power with single or dual power supply configuration is 300W. The minimum Cisco IOS Release supported on this power supply is the Cisco IOS Release 12.2(33)SCA.
- 540W AC-input power supply—The maximum AC-input power with single or dual power supply configuration is less than 700W. The minimum Cisco IOS Release supported on this power supply is the Cisco IOS Release 12.2(33)SCD.

**Note**

---

Ensure that you do not use a combination of these power supplies in the Cisco uBR7225VXR router.

---

The power supply contains a main power switch, Input OK and Output OK LEDs, AC-input power receptacle, and a two-hole grounding lug for the AC-input power supply. The grounding lug at the rear-bottom portion of the chassis provides a ground connection for electrostatic discharge (ESD) equipment.

The Cisco uBR7225VXR router supports an optional, second power supply for load-sharing and power redundancy. If you purchased a Cisco uBR7225VXR router and you want to install a second power supply, you must order the second power supply separately.

A handle on the AC-input power supply unit provides a grip point for removing and replacing the power supply. (Figure 1-8 on page 1-14 shows the faceplate of the AC-input power supply.)

A single captive installation screw secures the power supply to the chassis and seats the power supply in the router midplane. The AC-input power supply has a receptacle for an AC-input power cable. A modular power cable connects the AC-input power supply to the site AC power source.

Detailed instructions for handling and replacing the Cisco uBR7225VXR universal broadband router power supply is available in *Cisco uBR7200 Series Universal Broadband Router AC Power Supply Replacement Instructions*.

This document is available on Cisco.com at the following URL:

<http://www.cisco.com/en/US/docs/cable/cmts/ubr7200/installation/4848pwra.html>

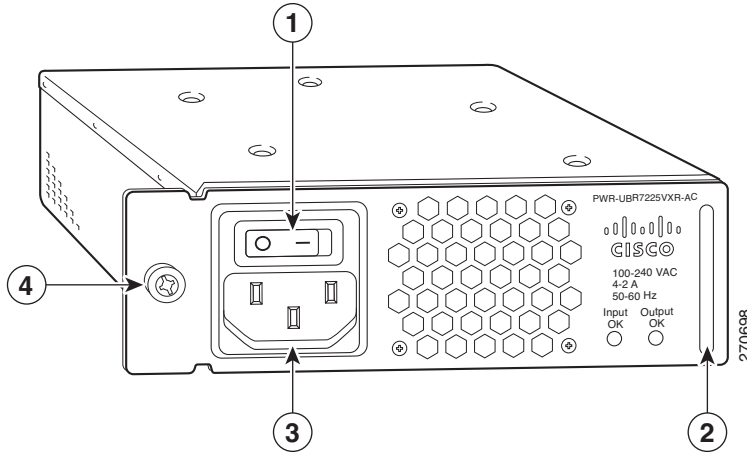
**Note**

---

For the Cisco uBR7225VXR router, the 300W AC-input power supply has an electrical input current rating of 4A with 100Vac input and the 540W AC-input power supply has an electrical input current rating of 6.5A with 100Vac input.

---

Figure 1-8 Cisco uBR7225VXR AC-Input Power Supply



1	Power switch	3	AC-input receptable
2	Handle	4	Captive installation screw

**Caution**

To ensure adequate airflow across the Cisco uBR7225VXR power supplies, a power supply or a power supply filler plate (with its attached air dam) must be installed in each power supply bay.

**Note**

See [Appendix A, “Cisco uBR7225VXR Router Specifications,”](#) for AC-input power supply system power specifications, including input voltage and operating frequency ranges.

The Cisco uBR7225VXR power supply shuts itself down when the input AC voltage, the output DC voltage, or the internal temperature of the chassis exceeds allowable tolerances. When this occurs, one or both of the power supply front panel LEDs will turn red. The Cisco uBR7225VXR power supply must then be reset by manually switching the power switch off and then back on to allow the router to recover.

**Caution**

When the input power to Cisco uBR7225VXR power supply is disconnected or lost, the power supply enters a reset cycle for 10 seconds. Wait at least 10 seconds or move the power switch from one position to the other to restart the power supply. For example, if the power supply was on when the power was disconnected or lost, move the power switch to the off position and then back to the on position. If you do not wait the full 10 seconds or move the power switch from one position to the other, the power supply does not restart.

## Fan Trays

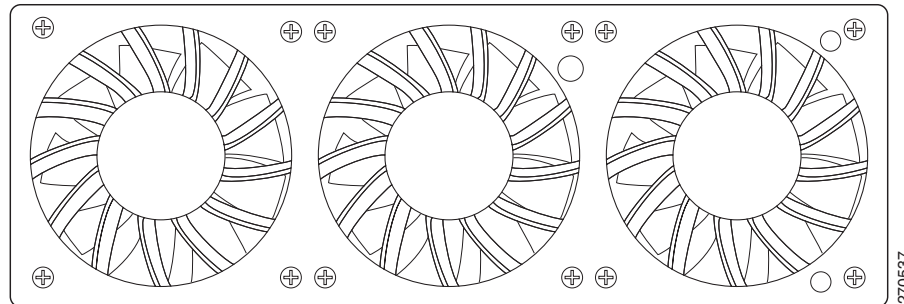
The fan tray for the Cisco uBR7225VXR router, shown in [Figure 1-9](#), consisting of three fans that are attached to a metal tray, is located on the left side of the chassis (when viewing the router from the front) and receives 12 VDC through a DC power harness that connects directly to the router midplane.

Temperature sensors on the network processing engine monitor the internal air temperature and send warning messages when the internal air temperature approaches a specified threshold. If the internal temperature exceeds the specified threshold, the system environmental monitor shuts down all internal power to prevent equipment damage from excessive heat.

**Note**

The Cisco uBR7225VXR router fan tray is not a field-replaceable unit.

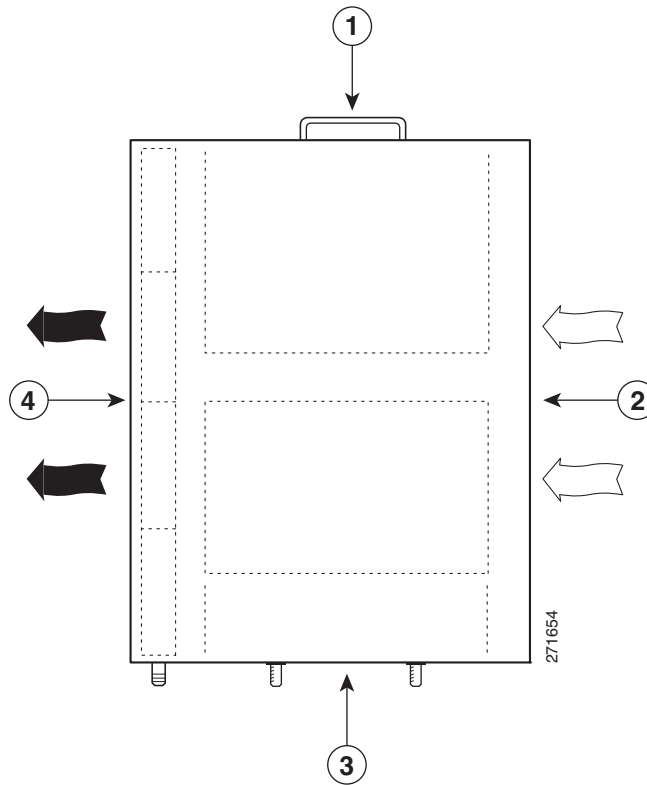
**Figure 1-9** Cisco uBR7225VXR Fan Tray



The fan tray draws cooling air in through the intake vent on the right side of the chassis (when viewing the router from the front) and moves the air across the internal components and sends it out through the exhaust vent on the left side of the chassis. [Figure 1-10](#) shows the airflow through the router.

The left and right sides of the chassis must remain unobstructed to ensure adequate airflow and prevent overheating inside the chassis; we recommend at least 3 inches of clearance. (See the [“Site Requirements”](#) section on page 2-5.)

Figure 1-10 Internal Airflow—Top View

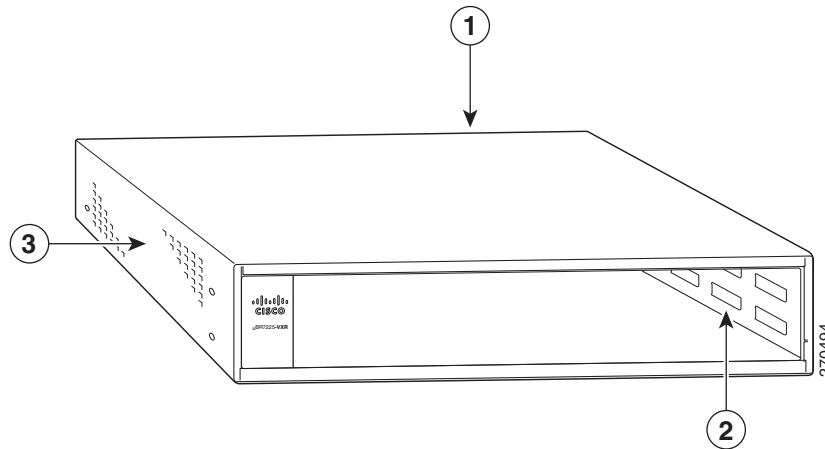


<b>1</b>	Power supply end	<b>3</b>	Cable interface line card end
<b>2</b>	Inlet flow	<b>4</b>	Exhaust air (fan side)

## Cisco uBR7225VXR Chassis

The front of the chassis has two slots for cable interface line cards and one bay for the subchassis. See [Figure 1-11](#).

**Figure 1-11** Cisco uBR7225VXR Chassis



<b>1</b>	Subchassis and midplane bay (at rear)	<b>3</b>	Fan tray
<b>2</b>	Cable interface line card slots		

## Subchassis and Midplane

The subchassis and midplane provide these functions for the Cisco uBR7225VXR router:

- Distributes power from the power supply.
- Bridges the peripheral component interconnect (PCI) buses from the cable interface line cards to the Cisco uBR7200-NPE-G1 or the Cisco uBR7200-NPE-G2.
- Arbitrates traffic across the PCI buses.

## Cisco uBR7225VXR Subchassis

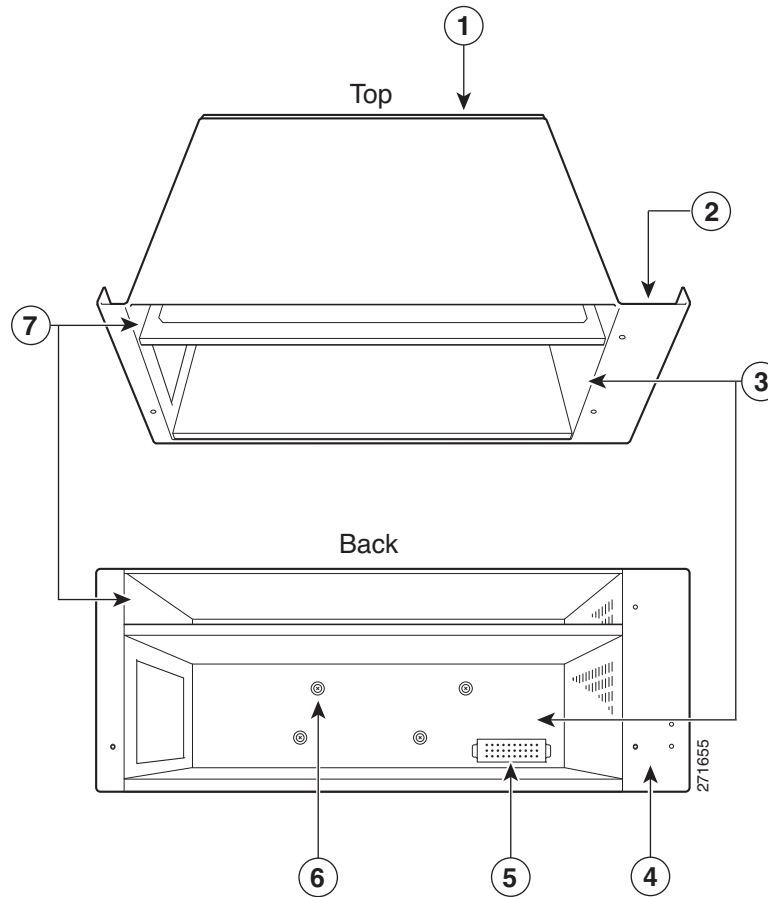
The subchassis (the rear of the router) has two bays for power supplies and one slot for a network processing engine. (See [Figure 1-12](#).) The cable interface card side of the Cisco uBR7225VXR router midplane has two connectors for cable interface line cards.

The power supply side of the midplane has two connectors for power supplies and one connector for a network processing engine. The midplane supplies DC power to the router's internal components.

Refer to the *Cisco uBR7200 Series Universal Broadband Router Subchassis and Midplane Replacement Instructions* at the following URL:

<http://www.cisco.com/en/US/docs/cable/cmts/ubr7200/installation/5193sbm.html>

Figure 1-12 Cisco uBR7225VXR Subchassis and Midplane



1	Midplane	5	Power supply receptacle
2	Fan tray slot	6	Captive installations screws (6)
3	Power supply bays	7	Network processing engine slot
4	Fan tray slot		

## CompactFlash Disk

The Cisco uBR7225VXR universal broadband router has one CompactFlash Disk slot that uses CompactFlash Disks. The device in this slot is always addressed as disk2: when using Cisco IOS command-line interface (CLI) commands.

CompactFlash Disks are smaller in size than Type 2 Flash Disks but provide the same AT Attachment (ATA) interface and equivalent functionality. This interface complies with the ANSI ATA Interface Document X3T13.1153 D Rev. 9 specification. The CompactFlash Disk provides 512 MB or 1 GB of storage space.

The CompactFlash Disk has controller circuitry that allows it to emulate a hard disk and automatically maps out bad blocks and performs automatic block erasure. The CompactFlash Disk also provides the capability to allocate noncontiguous sectors, which eliminates the need for the **squeeze** command (which was required with older-style linear flash memory cards to recover the space used by deleted files).

The CompactFlash Disk also supports the Cisco IOS File System feature, which provides a single interface to all of the router's file systems, including the Flash Disks and flash memory, as well as network file systems such as File Transfer Protocol (FTP) and Trivial FTP (TFTP) servers.

**Note**

---

All CompactFlash Disks must be formatted before their initial use. CompactFlash Disks shipped with the NPE-G2 are formatted at the factory, but spare memory cards are not formatted.

---







## CHAPTER 2

# Preparing the Cisco uBR7225VXR Router for Installation

---

This chapter describes the site requirements for installing the Cisco uBR7225VXR universal broadband router and contains the following sections:

- [Safety Recommendations, page 2-1](#)
- [Site Requirements, page 2-5](#)
- [Required Network Information, page 2-7](#)
- [Installation Tools, page 2-8](#)
- [Rack-Mount and Cable-Management Kit, page 2-8](#)
- [Equipment Required to Verify Your Plant's RF Setup, page 2-9](#)
- [Shipping Container Contents, page 2-9](#)
- [Provisioning the Cable Headend, page 2-10](#)
- [Site Preparation Checklist, page 2-17](#)
- [Component Checklists, page 2-18](#)

## Safety Recommendations

The following safety guidelines will help to ensure your safety and protect the equipment. This list does not cover all potentially hazardous situations, so *be alert*. Before installing, configuring, or maintaining the Cisco uBR7225VXR router, review the safety warnings listed in the *Regulatory Compliance and Safety Information for Cisco uBR7200 Series Universal Broadband Routers* at the following URL:

<http://www.cisco.com/en/US/docs/cable/cmts/ubr7200/regulatory/compliance/ub72res.html>

The installation of your Cisco uBR7225VXR universal broadband router should be in compliance with national and local electrical codes.

Other safety issues to be aware of:

- Never attempt to lift an object that might be too heavy for you to lift by yourself.
- Always turn all power supplies off and unplug all power cables before opening the chassis.
- Always unplug the power cable before installing or removing a chassis.
- Keep the chassis area clear and dust-free during and after installation.
- Keep tools and chassis components away from walk areas.

- Do not wear loose clothing, jewelry (including rings and chains), or other items that could get caught in the chassis.
- For systems with installed AC-input power supplies, the Cisco uBR7225VXR router ships with a 3-wire electrical grounding-type plug, which only fits into a grounding-type power outlet. This is a safety feature. The equipment grounding should be in accordance with local and national electrical codes.
- The Cisco uBR7225VXR router operates safely when it is used in accordance with its marked electrical ratings and product usage instructions.

**Warning**


---

**Only trained and qualified personnel should be allowed to install or replace this equipment.**

Statement 1030

---

**Note**


---

For Australia and New Zealand, equipment is to be installed and maintained by service personnel only as defined by AS/NZS 3260 Clause 1.2.14.3 Service Personnel.

---

**Warning**


---

**Ultimate disposal of this product should be handled according to all national laws and regulations.**

Statement 1040

---

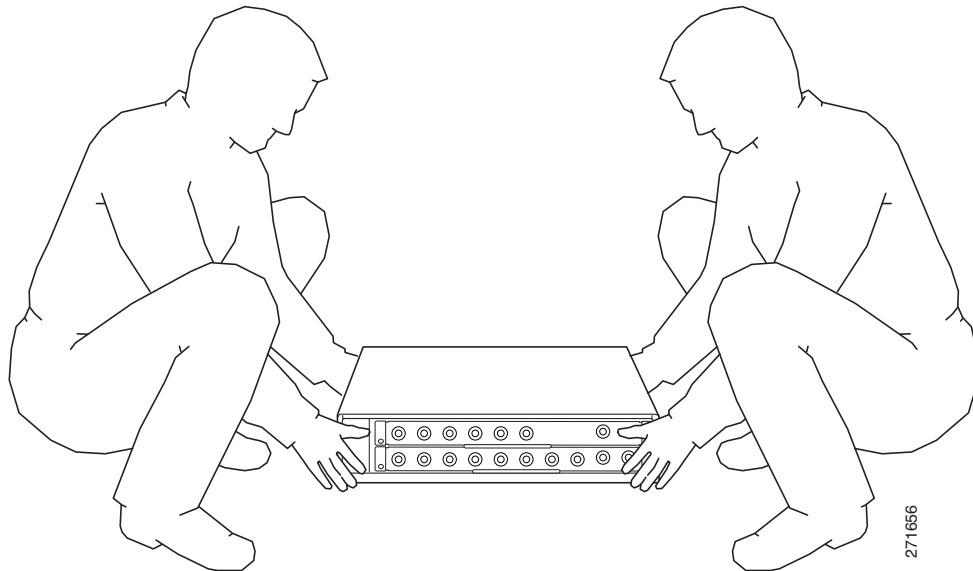
## Lifting the Cisco uBR7225VXR Router Safely

Before you install the router, ensure that your site configuration is properly designed and prepared so that you can avoid having to move the router later to accommodate power sources and network connections.

A fully-configured Cisco uBR7225VXR router (with two 300W power supplies) weighs approximately 48 pounds (21.8 kilograms).

Whenever you lift a chassis or any heavy object, follow these guidelines:

- Always disconnect all external cables before lifting or moving the chassis.
- Do not attempt to lift the chassis by yourself; have someone assist you (see [Figure 2-1 on page 2-3](#)).
- Ensure that your footing is solid, and balance the weight of the object between your feet.
- Lift the chassis slowly; never move suddenly or twist your body as you lift.
- Keep your back straight and lift with your legs, not your back. If you must bend down to lift the chassis, bend at the knees, not at the waist, to reduce the strain on your lower back muscles.
- Lift the chassis from the bottom; grasp the underside of the chassis exterior with both hands.

**Figure 2-1 Lifting the Chassis (Cisco uBR7246 Router Shown)****Warning**

**Two people are required to lift the chassis. Grasp the chassis underneath the lower edge and lift with both hands. To prevent injury, keep your back straight and lift with your legs, not your back. To prevent damage to the chassis and components, never attempt to lift the chassis with the handles on the power supplies or on the interface processors, or by the plastic panels on the front of the chassis. These handles were not designed to support the weight of the chassis. Statement 5**

## Safety with Electricity

Follow these basic guidelines when working with any electrical equipment:

- Before beginning any procedures requiring access to the chassis interior, locate the emergency power-off switch for the room in which you are working.
- Carefully examine your work area for possible hazards such as moist floors, ungrounded power extension cables, and missing safety grounds.
- Disconnect all power and external cables before installing or removing a chassis.
- Never assume that power has been disconnected from a circuit; always check.
- Do not perform any action that creates a potential hazard to people or makes the equipment unsafe.
- Do not work alone if potentially hazardous conditions exist.
- Never install equipment that appears damaged.

**Caution**

You *must* power down the system before removing or replacing the network processing engine. The cable interface line cards and redundant power supplies are designed to be removed and replaced while the system is operating, without presenting an electrical hazard or damage to the system.

**Warning**


---

**The telecommunications lines must be disconnected 1) before unplugging the main power connector and/or 2) while the housing is open.** Statement 89

---

**Warning**


---

**Before working on a chassis or working near power supplies, unplug the power cord on AC units; disconnect the power at the circuit breaker on DC units.** Statement 246

---

**Warning**


---

**Do not work on the system or connect or disconnect cables during periods of lightning activity.** Statement 1001

---

In addition, use the guidelines that follow when working with any equipment that is disconnected from a power source, but still connected to telephone wiring or other network cabling:

- Never install telephone wiring during a lightning storm.
- Never install telephone jacks in wet locations unless the jack is specifically designed for wet locations.
- Never touch uninsulated telephone wires or terminals unless the telephone line has been disconnected at the network interface.
- Use caution when installing or modifying telephone lines.

## Preventing Electrostatic Discharge Damage

Electrostatic discharge (ESD) damage, which occurs when electronic cards or components are improperly handled, can result in complete or intermittent system failures. The network processing engine and cable interface line cards consist of a printed circuit board that is fixed in a metal carrier. Electromagnetic interference (EMI) shielding, connectors, and a handle are integral components of the carrier. Although the carrier helps protect the boards, use an antistatic strap whenever handling the network processing engine and cable interface cards. Handle the carriers by the handles and the carrier edges only; never touch the boards or connector pins.

**Caution**


---

Always tighten the captive installation screws on the network processing engine and cable interface line cards. These screws prevent accidental removal, provide proper grounding for the system, and help ensure that the bus connectors are properly seated in the midplane.

---

Following are guidelines for preventing ESD damage:

- Always use an ESD wrist strap or ankle strap and ensure that it makes good skin contact.
- When handling a removed network processing engine or cable interface line card, make sure that the equipment end of your ESD strap is attached to an unfinished chassis surface of the router; *do not* touch the printed circuit board, and avoid contact between the printed circuit board and your clothing. Always place the network processing engine or cable interface line card component side up on an antistatic surface or in a static shielding bag. If you are returning the item to the factory, immediately place it in a static shielding bag.

- Ensure that the network processing engine is fully inserted in its chassis slot and the captive installation screws are tightened. The captive installation screws prevent accidental removal, provide proper grounding for the system, and help ensure that the bus connectors are seated in the midplane.
- Ensure that each cable interface line card is fully inserted in its chassis slot and that its captive installation screws are tightened.

**Caution**

For safety, periodically check the resistance value of the antistatic strap. The measurement should be between 1 and 10 megohms.

## Site Requirements

To ensure normal operation and avoid unnecessary maintenance, plan your site configuration and prepare your site *before* installation. Take into account the following criteria:

- Verify that your cable network meets system requirements and DOCSIS or EuroDOCSIS downstream and upstream specifications.
- Select forward and reverse channel frequencies from the range specified in your channel plan.
- Make sure that the site maintains an ambient temperature of 32 to 104°F (0 to 40°C), and keep the area around the chassis as free from dust as is practical.

**Note**

To locate the most reliable channels for your downstream and upstream channel plans, we recommend that you perform a sweep of all available channels for at least a 24-hour period to verify the presence or absence of impulse or ingress noise.

## AC Power

The AC-input power supply uses a power factor corrector that allows the Cisco uBR7225VXR router to operate on input voltage and frequency within the ranges of 100 to 240 VAC and 50/60 Hz.

**Note**

We recommend an uninterruptable power source to protect against power failures at your site. For the Cisco uBR7225VXR router, the 300W AC-input power supply has an electrical input current rating of 4A with 100Vac input and the 540W AC-input power supply has an electrical input current rating of 6.5A with 100Vac input.

See [Appendix A, “Cisco uBR7225VXR Router Specifications,”](#) for system power specifications, including input voltage and operating frequency ranges.

## Site Environment

[Table 2-1](#) lists the operating and nonoperating environmental site requirements. The following ranges are those within which the Cisco uBR7225VXR router continues to operate; however, a measurement that is approaching the minimum or maximum of a range indicates a potential problem. You can maintain normal operation by anticipating and correcting environmental anomalies before they approach the minimum or maximum of an operating range.

To provide airflow through the Cisco uBR7225VXR router, cooling air is drawn in through the air intake vent on the right side of the chassis (when viewing the router from the front) and is exhausted through the left side of the chassis. Keep the right and left sides of the chassis clear of obstructions and away from the exhaust of other equipment.

**Note**

The Cisco uBR7225VXR router is suitable for installation in Network Telecommunication Facilities and locations where the National Electrical Code (NEC) applies. The Cisco uBR7225VXR router is not intended for installation in outside plant (OSP) locations.

**Table 2-1** Specifications for Operating and Nonoperating Environments

Specification	Minimum	Maximum
Temperature, ambient operating	32°F (0°C)	104°F (40°C)
Temperature, ambient nonoperating and storage	-4°F (-20°C)	149°F (65°C)
Humidity, ambient (noncondensing) operating	10%	90%
Humidity, ambient (noncondensing) nonoperating and storage	5%	95%
Altitude, operating and nonoperating	Sea level	10,000 feet (3,050 meters)
Vibration, operating	5 to 200 Hz, 0.5 g (1 oct./min.)	–
Vibration, nonoperating	5 to 200 Hz, 1 g (1 oct./min.) 200 to 500 Hz, 2 g (1 oct./min.)	–

## Site Configuration: Maintaining Normal Operation

Planning a proper location for the Cisco uBR7225VXR universal broadband router and the layout of your equipment rack or wiring closet are essential for successful system operation. Equipment placed too close together or inadequately ventilated can cause system overtemperature conditions. In addition, chassis panels made inaccessible by poor equipment placement can make system maintenance difficult. Following are precautions that can help avoid problems during installation and ongoing operation.

## General Precautions

Follow these general precautions when planning your equipment locations and connections:

- Use the **show environment** command regularly to check the internal system status. The environmental monitor continually checks the interior chassis environment; it provides warnings for high temperature and maximum and minimum voltages and creates reports on any occurrences. If warning messages are displayed, take immediate action to identify the cause and correct the problem.
- We recommend keeping the Cisco uBR7225VXR router off the floor and out of any area that tends to collect dust, excessive condensation, or water.
- Follow ESD prevention procedures to avoid damage to equipment. Damage from static discharge can cause immediate or intermittent equipment failure.

- Ensure that the network processing engine, cable interface line cards, any blank cable interface line cards, power supplies, and any power supply filler plates are in place and secure. The fans direct cooling air throughout the chassis interior; a loose component or empty slot can redirect the airflow away from active components and cause overheating.

## Power Considerations

Follow these precautions and recommendations when planning power connections to the Cisco uBR7225VXR router:

- Check the power at your site before installation and periodically after installation to ensure that you are receiving clean power. Install a power conditioner and appropriate surge suppression if necessary.
- Install proper grounding to avoid damage from lightning and power surges.

## Required Network Information

After you install the chassis, your system administrator must configure the individual and system interfaces before you connect your system to external networks. Refer to the following documentation for configuration information.

*Cisco uBR7200 Series Software Configuration Guide* at the following URL:

<http://www.cisco.com/en/US/docs/cable/cmts/ubr7200/configuration/guide/cr72scg.html>

*Cisco IOS CMTS Cable Software Configuration Guide* at the following URL:

[http://www.cisco.com/web/techdoc/cable/Config/Sw\\_conf.html](http://www.cisco.com/web/techdoc/cable/Config/Sw_conf.html)

*Cisco IOS CMTS Cable Command Reference Guide* at the following URL:

[http://www.cisco.com/en/US/docs/ios/cable/command/reference/cbl\\_book.html](http://www.cisco.com/en/US/docs/ios/cable/command/reference/cbl_book.html)

## Before You Begin

Be prepared with global (system-wide) parameters such as:

- Hostnames
- Passwords
- Routing protocols
- Configuration information for each interface, such as:
  - Addresses
  - Rates or speeds of operation
  - Routing protocol specifics

Following is the information you might need, depending on the services you plan to offer:

- Hostname for the router.
- Passwords to prevent unauthorized privileged-level access to the EXEC command interpreter and for individual virtual terminal lines.
- Protocols you plan to route.

- IP addresses and subnet masks, if you are routing IP.
- Dial-up access telephone numbers, usernames, and passwords for telco return operation.
- RADIUS security and accounting configuration.
- Gateway and gatekeeper zone configuration for your H.323 VoIP network.
- Gateway and call-agent configuration for your SGCP VoIP network.
- Zone names, network numbers, or node numbers for the new interfaces, if required.
- Operating speeds for specific interfaces—For example, serial interfaces operate at speeds of up to 2 Mbps. The speed of an interface often depends on the speed of the remote device to which it is attached.

## Installation Tools

Your Cisco uBR7225VXR universal broadband router chassis is fully assembled at the factory; no assembly is required. However you will need the following tools and equipment to install the chassis and the rack-mount and cable-management kit:

- Number 2 Phillips screwdriver
- 3/16-inch flat-blade screwdriver
- 7/16-inch flat-blade screwdriver
- 7/16-inch torque wrench for connecting coaxial cables to the cable F-connectors on the cable interface line cards—Recommended torque is 20 inch-pounds (optional)
- Tape measure (optional)
- Level (optional)

## Rack-Mount and Cable-Management Kit

The rack-mount and cable-management kit includes the following parts:

- Two rack-mount brackets for mounting the chassis in the rack.
- Cable-management bracket to relieve the strain on installed cable interface line card interface cables.
- Eight M4 x 6-mm Phillips flathead screws to secure the rack-mount brackets to the chassis.
- Four M3 x 6-mm Phillips panhead screws to secure the cable-management bracket to the chassis.
- Four 10/32 x 3/8-inch slotted binderhead screws to secure the rack-mount brackets to the rack rails.

For more information on the rack-mount brackets and cable-management bracket, refer to the [“Cisco uBR7225VXR Router Chassis Rack-Mounting Options”](#) section on page 3-2.



# Equipment Required to Verify Your Plant's RF Setup

To verify your plant's RF setup, you need the following:

- RF spectrum analyzer
- For coaxial cabling:
  - Diplex filters/splitters
  - Coaxial cable crimping tool
  - New coaxial cable
  - Coaxial jumpers that are at least 2 to 3 feet long (maximum of 5 feet)
- For fiber networks, optical receivers for each upstream optical path
- Assorted RF attenuators (with at least two 20-dB attenuators)

**Note**

For headend RF and data setups, refer to [Chapter 4, “Connecting the Cisco uBR7225VXR Router to the Cable Headend.”](#) Refer to [Appendix F, “Manufacturers for Headend Provisioning Requirements,”](#) for a list of manufacturers. Refer to [Appendix C, “Cable Specifications,”](#) for coaxial cabling specifications.

In addition, you might need the following:

- Crossover Ethernet cable with RJ-45 connectors—If you plan to connect a computer directly to an Ethernet port in the Cisco uBR7225VXR router, you need this type of cable.
- Fast Ethernet transceiver.
- DOCSIS cable modem or DOCSIS-based STB and CPE devices to test full system functionality.

**Note**

When the Cisco uBR7225VXR router starts running, IF downstream output is generated. For more information, see the [“Powering On the Cisco uBR7225VXR Router”](#) section on page 3-18.

## Shipping Container Contents

When you receive your Cisco uBR7225VXR universal broadband router, use the following procedure to check the contents of the shipping container. Use the [Cisco uBR7225VXR Router Installation Checklist](#) or the [“Component Checklists”](#) section on page 2-18 to ensure you received all the components that you ordered.

**Note**

Do not discard the shipping container. You will need the container if you move or ship your Cisco uBR7225VXR router in the future.

## Verifying the Shipping Container Contents

- Step 1** Verify that the following are included in the shipping container (the accessories box might be separate):
- One Cisco uBR7225VXR universal broadband router chassis containing all of the components you ordered for your system (except the rack-mount and cable-management kit)

- One or more accessories boxes (some or all might be shipped separately)
- Step 2** Check the contents of the accessories box against the “Component Checklist” and the packing slip to verify that you received all listed equipment, which should include the following:
- One modular power cable for an AC-input power supply. (If you purchased a Cisco uBR7225VXR router with a redundant power supply, you should receive two power cables.)
  - One rack-mount and cable-management kit (3 brackets and 14 mounting screws).
  - Optional equipment that you ordered, such as network interface cables, transceivers, or special connectors.
  - CNR or CSRC provisioning documentation, or both.
  - Cisco IOS software documentation, if ordered.
- Step 3** Verify that the number of cable interface line cards installed in your Cisco uBR7225VXR router matches the number of cable interface line cards that you ordered.
- Step 4** Refer to [Appendix G, “Site Log,”](#) then to the “[Cisco uBR7225VXR Router Chassis Rack-Mounting Options](#)” section on page 3-2 to begin the installation.
- 

## Provisioning the Cable Headend

This section describes the necessary preparations to make at the cable headend before you install the Cisco uBR7225VXR universal broadband router.

### Two-Way Data and VoIP

To prepare for two-way data operation, including digitized voice and fax, ensure that the following conditions are met:

- The cable headend equipment is properly aligned and certified for two-way transmission based on procedures provided by the manufacturers of the equipment and in accordance with DOCSIS or EuroDOCSIS RF Interface Specifications.
- The cable headend is wired for narrowcast downstream data transmission.
- The cable headend is wired to supply an RF feed from the upstream fiber-optic receivers to the Cisco uBR7225VXR router.
- Upstream frequencies are allocated for data transmission.
- Upstream impairments are measured and understood, and comply with recommendations in DOCSIS or EuroDOCSIS RF interface specifications.
- Upstream ports are configured as appropriate to support frequency agility.
- Downstream frequencies are assigned.
- Internet connectivity is established.
- Internet addresses are obtained and allocated.
- All RF connectivity is verified.

**Note**

For a VoIP system using H.323, ensure that the CMTS has been properly provisioned with equipment such as VoIP gateways and gatekeepers. For SGCP-based VoIP systems, ensure that the CMTS has been properly provisioned with equipment such as VoIP gateways and call-agents.

## Headend Certification

The cable headend plant must pass both analog and digital certification:

- In the United States, the Federal Communications Commission (FCC) mandates minimum technical performance requirements for cable systems.
- For international requirements, consult with local agencies for certification requirements.

The digital certification process is described in [Chapter 4, “Connecting the Cisco uBR7225VXR Router to the Cable Headend.”](#)

## Diplex Filters

For coaxial cabling, diplex filters must be installed in the RF path between the cable interface cards in the Cisco uBR7225VXR universal broadband router and cable interfaces and STBs. Diplex filters separate the downstream signals from the upstream signals.

**Note**

For fiber optics, laser transmitters and optical receivers handle the frequency separation of upstream and downstream. Refer to the [“Receivers” section on page 2-11](#).

High-frequency signals flow in the downstream direction from the Cisco uBR7225VXR router to cable interfaces and STBs. Low-frequency signals flow in the upstream direction from the cable interfaces to the Cisco uBR7225VXR router.

A diplex filter has three ports: low, high, and common. The downstream attaches to the high port because it runs at high frequency. The upstream attaches to the low port because it runs at a low frequency. The common port attaches to a splitter attached to one or more cable interfaces and STBs.

In two-way cable networks, the diplex filter takes the upstream and downstream and combines them on one cable for the cable interface. The downstream output signal from the Cisco uBR7225VXR router runs through the upconverter and then enters the high filter port of the diplex filter. The signal exits the common port of the filter and is distributed to the cable interfaces. The upstream signal from the cable modem enters the common port of the diplex filter and flows to the upstream receive ports of the Cisco uBR7225VXR cable interface line cards through the diplex filters' low port.

**Note**

[Appendix F, “Manufacturers for Headend Provisioning Requirements,”](#) provides a list of diplex filter manufacturers and websites for more information.

## Receivers

If the upstream channels of your cable plant terminate at the headend over fiber-optic lines, ensure that you have a receiver allocated for each upstream in your network.

## DHCP, DNS, TFTP, and TD Servers

A DHCP server must be installed at the headend. The DHCP server must also offer a time-of-day (TD) server option that is compliant with RFC 868.

In conjunction with the DHCP server, a Domain Name System (DNS) server must be installed to translate names of network nodes into IP addresses. A TFTP server must be installed to facilitate the transfer of DOCSIS configuration files over the broadband network.

Cisco provides a configuration tool with every Cisco uBR7225VXR universal broadband router—Cisco Network Registrar (CNR)—to automate dynamic IP address allocation to cable interfaces, PCs, and other devices on the broadband network. CNR provides integrated DHCP and DNS services for your network configuration.

## Telco Return

To support telco return, ensure that:

- Your downstream plant meets DOCSIS or EuroDOCSIS specifications.
- Your headend is wired for narrowcast downstream data transmission.
- You have assigned downstream frequencies.
- All equipment needed to support upstream traffic over the PSTN, as well as to monitor telco return service features is installed. Key components include:
  - Dial-up access server (for example, the Cisco AS5300 or Cisco AS5800)
  - RADIUS dial security server
- All third-party, telco return cable interfaces are DOCSIS-compliant.
- Your Cisco IOS software image supports telco return functionality.

The following sections describe CMTS equipment necessary to support telco return service.

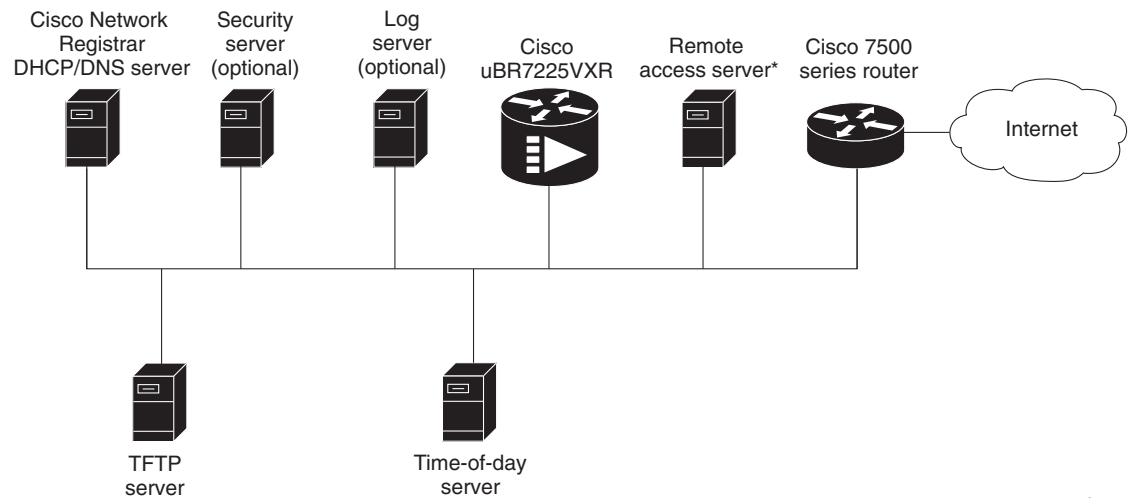
## Dial-Up/Remote Access Servers

Because a telco return cable network relies on the local telephone system to complete the upstream data path to the Cisco uBR7225VXR router, you need to be sure that you provision your network with a dial-up access server and other required equipment through which remote cable interfaces will gain access to your headend.

## RADIUS Dial Security Servers

After remote telco return cable interfaces have initiated dial-up to the CMTS via the network access server, a RADIUS dial security server typically authenticates their respective usernames and passwords or MAC address and passwords and then determines whether or not to allow the connection.

In addition to the dial-up numbers provided in telephony channel descriptor (TCD) messages originating from the Cisco uBR7225VXR router, username and password information is included in TCD messages to validate the cable interface's upstream connection. After dialing in to the network access server, the username and password portions of the TCD messages are passed through a RADIUS dial access server for authentication before the upstream data path can be completed. (See [Figure 2-2](#).)

**Figure 2-2 Servers on an HFC Network**

\*A remote access server is required on an HFC network only when you want to offer VoIP using H.323 or telco return service.

271657

## Authentication, Authorization, and Accounting Servers

Authentication, authorization, and accounting (AAA) servers are essential to the network, because they typically monitor usage for subscriber billing and record keeping. AAA features call upon a RADIUS security server to help authenticate and monitor users' access.

## VoIP Gateways and Gatekeepers

To support digitized voice transmission on uBR7225VXR router using Cisco IOS Release 12.2(33)SCA CMTS images, be sure to include VoIP gateways and gatekeepers in your configuration. Cisco IOS Release 12.2(33)SCA supports VoIP by using the H.323 protocol. VoIP gateways convert IP-based voice packets into standard PSTN voice traffic, making the process of placing calls over the IP network transparent to users.

VoIP gatekeepers manage H.323-compliant gateways throughout the network. Gatekeepers also manage traffic between their local cable system networks, as well as the networks of other VoIP gatekeepers.

## VoIP SGCP Pass-Through

To support digitized voice transmission using Simple Gateway Control Protocol (SGCP), be sure to include VoIP gateways and external call control elements (often referred to as call-agents) in your configuration. Cisco IOS Release 12.2(33)SCA and later versions support VoIP communication using the SGCP 1.1 protocol on uBR7225VXR. Just as with H.323 systems, VoIP gateways in an SGCP environment convert IP-based voice packets into standard PSTN voice traffic, making the process of placing calls over the IP network transparent to users.

Call-agents manage SGCP-compliant gateways throughout the network, allowing them to engage in common channel signaling (CCS) over a 64-kbps circuit emulation service (CES) circuit.

## Headend Wiring

This section provides guidelines for setting up the headend wiring and cabling at your site. When planning the location of the new system, consider the distance limitations for signaling, EMI, and connector compatibility, as described in the following sections.

### Interference Considerations

When wires are run for any significant distance in an electromagnetic field, interference can occur between the field and the signals on the wires. This fact has two implications for the construction of headend wiring:

- Bad wiring practice can result in radio interference emanating from the wiring, ingress noise, co-channel interference, and degraded or erratic universal broadband router performance.
- Strong EMI, especially when caused by lightning or radio transmitters, can destroy the signal drivers and receivers in the Cisco uBR7225VXR router, and can even create an electrical hazard by conducting power surges through lines and into equipment. (Review the safety warnings in the [“Safety with Electricity”](#) section on page 2-3.)

If you use twisted-pair cable in your headend wiring with a good distribution of grounding conductors, the wiring is unlikely to emit radio interference. If you exceed the recommended distances, use a high-quality twisted-pair cable with one ground conductor for each data signal when applicable.

If wires exceed recommended distances, or if wires pass between buildings, give special consideration to the effect of a lightning strike in your vicinity. The electromagnetic pulse caused by lightning or other high-energy phenomena can easily couple enough energy into unshielded conductors to destroy electronic devices. If you have had EMI problems in the past, you might want to consult experts in electrical surge suppression and shielding.

### Distance Limitations and Interface Specifications

The size of your networks and the distances between connections depend on the type of signal, the signal speed, and the transmission media (the type of cabling used to transmit the signals). For example, standard coaxial cable has a greater channel capacity than twisted-pair cabling. The distance and rate limits are the IEEE-recommended maximum speeds and distances for signaling; however, you can usually get good results at speeds and distances far greater than these. For example, the recommended maximum rate for V.35 is 2 Mbps, and it is commonly used at 4 Mbps without any problems. If you understand the electrical problems that might arise and can compensate for them, you should get good results with rates and distances greater than those recommended by IEEE; however, do so at your own risk.

**Note**

---

We recommend that you do not exceed specified transmission rate and distance limits.

---

When preparing your site for network connections to the Cisco uBR7225VXR router, you must consider a number of factors related to each type of interface:

- The type of cabling required for each type of interface (fiber, thick or thin coaxial, shielded twisted-pair, or unshielded twisted-pair cabling)
- Distance limitations for each signal type
- The specific cables you need to connect each interface

- Any additional interface equipment you need, such as transceivers, hubs, switches, modems, channel service units (CSUs), or data service units (DSUs)
- Cable pinouts if you plan to build your cables

Before installing the Cisco uBR7225VXR router, have all additional external equipment and cables available. The information listed above is available at [Cisco.com](http://Cisco.com). For ordering information, contact a customer service representative.

## Equipment Racks

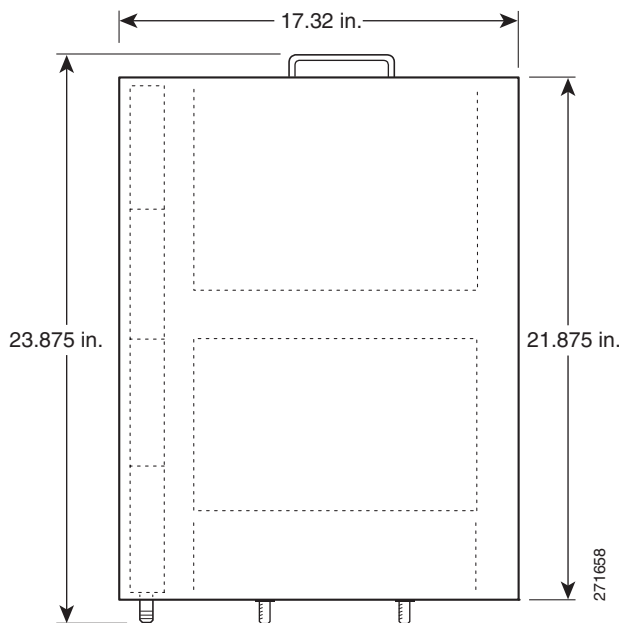
The rack-mounting hardware included with the Cisco uBR7225VXR universal broadband router is suitable for most 19-inch equipment racks and telco-type racks. To easily access field-replaceable units (FRUs) while the router is installed in a rack, ensure that you have access to the front and rear of the router.

Before using a particular rack, check for obstructions (such as a power strip) that could impair rack-mount installation. If a power strip impairs a rear rack-mount installation, remove the power strip before installing the Cisco uBR7225VXR router in the rack, then replace it after the chassis is installed. As an alternative, you can mount the Cisco uBR7225VXR router on an equipment shelf if the rack dimensions allow you to secure the router to the shelf, and the overall configuration permits safe installation and access. However, we recommend rack-mounting the Cisco uBR7225VXR router. [Figure 2-3 on page 2-16](#) shows the Cisco uBR7225VXR router footprint and outer dimensions.

When rack-mounting the Cisco uBR7225VXR router, consider the following information:

- To mount the router between two posts or rails using the brackets, the inner clearance (the width between the *inner* sides of the two posts or rails) must be at least 17.5 inches (44.45 cm).
- The height of the Cisco uBR7225VXR chassis is 3.5 inches (8.89 cm).
- When mounting the router in four-post or telco-type racks, be sure to use all the screws and the brackets provided to secure the chassis to the rack posts.

**Figure 2-3** Cisco uBR7225VXR Router Footprint and Outer Dimensions (View from Top Looking Down)



**Note**

We recommend the rear bracket mounting system for four-post racks because this method enables you to keep cables from protruding too far out in front of the Cisco uBR7225VXR router, and simultaneously manage the cables at the front of the chassis with the cable-management bracket.

When planning your rack installation, consider the following information:

- Install the Cisco uBR7225VXR router in an open rack whenever possible. If installation in an enclosed rack is unavoidable, ensure that the rack has adequate ventilation.
- If you plan to use an equipment shelf, ensure that the shelf is constructed to support the weight and dimensions of the chassis. [Figure 2-3](#) shows the chassis footprint, which you will need if you are designing a customized shelf. We recommend that you use the rack-mount kit for the Cisco uBR7225VXR router (product number ACS-uBR7225-RMK=).
- Allow sufficient clearance around the rack for maintenance. If the rack is mobile, you can push it back near a wall or cabinet for normal operation and pull it out for maintenance (connecting cables, or replacing or upgrading components). Otherwise, allow at least 23.25 inches (59.06 cm) of clearance at the front, and 19 inches (48.3 cm) at the back to remove any of the field-replaceable units.
- Maintain a minimum clearance of 3 inches (7.72 cm) on the right and left of the chassis for the cooling air inlet and exhaust ports, respectively. Avoid placing the Cisco uBR7225VXR router in an overly congested rack or directly next to another equipment rack; otherwise, the heated exhaust air from other equipment can enter the inlet air vents and cause an overtemperature condition inside the router.
- Always install heavier equipment in the lower half of a rack to maintain a low center of gravity and prevent the rack from falling.
- If you use telco-type racks, be sure that the rack is bolted to the floor and secured, because in these types of installations, only one end of the chassis mounts to the two rack posts with the brackets. Ensure that the weight of the chassis does not make the rack unstable.



- Install and use the cable-management bracket included with the Cisco uBR7225VXR rack-mount kit to keep cables organized. Consider the equipment and cabling that is already installed in the rack. Ensure that cables from other equipment will not impair access to the interface slots, or require you to disconnect cables unnecessarily to perform equipment maintenance or upgrades.

In addition to the preceding guidelines, review the precautions for avoiding overtemperature conditions in the “[Site Environment](#)” section on page 2-5. To properly install the Cisco uBR7225VXR router chassis in a rack, refer to the instructions in the “[Cisco uBR7225VXR Router Chassis Rack-Mounting Options](#)” section on page 3-2.

**Caution**

Do not install the Cisco uBR7225VXR chassis in an enclosed rack or room that is not properly ventilated or air-conditioned. The Cisco uBR7225VXR chassis overheats if the input air temperature reaches 105°F (41°C).

## Site Preparation Checklist

Before installing the Cisco uBR7225VXR router, assemble the equipment needed to support your network configuration and subscriber service offering. Ensure all power and cabling requirements are met based on the equipment to be installed. Also ensure that environmental conditions are met to maintain proper equipment operation.

[Table 2-2](#) is a checklist that identifies the key tasks to complete.

**Table 2-2**      **Site Preparation Checklist**

Task	Verified By	Date
<b>General:</b>		
Safety recommendations and guidelines reviewed.		
Required general CMTS preparations completed.		
Site power voltages verified.		
Site environmental specifications verified.		
Downstream and upstream channel plans created.		
Cable plant balanced, swept and verified to comply with DOCSIS or EuroDOCSIS recommendations.		
Optical receivers adjusted for proper upstream RF output levels.		
Required passwords, IP addresses, device names available.		
All additional CMTS equipment to support Internet access services, RF-related equipment, servers and other host computers, a Cisco uBR900 series cable access router, and console accessory kit to test operation of your network available.		
Required tools and cables available.		
<b>Telco Return Configurations:</b>		
Telco return dial-up plan created.		
Network access server installed and configured.		
Telephone circuits, connections, and all equipment to support telco return available.		
<b>IP Telephony Configurations:</b>		

Table 2-2 Site Preparation Checklist (continued)

Task	Verified By	Date
Gatekeeper and gateway equipment installed and configured.		
Dial plan based on the supported VoIP protocol used—H.323 or SGCP.		

## Component Checklists

- Check off the equipment as it is unpacked.
- Titles and quantities of documents will vary.

Table 2-3 provides the list to verify the contents of the shipping container for the Cisco uBR7225VXR router.

Table 2-3 Cisco uBR7225VXR Router Component List

Description	Received
<ul style="list-style-type: none"> <li>• Cisco uBR7225VXR chassis</li> <li>• Network processing engine</li> <li>• Up to two AC-input power supplies and power cords (blank power supply filler plate should be installed in empty power supply slot)</li> <li>• Up to two cable interface line cards (blank cable interface line cards should be installed in empty cable interface line card slots)</li> <li>• CompactFlash Disk</li> </ul>	
<p>The following accessories might arrive in separate shipping containers:</p> <ul style="list-style-type: none"> <li>• Rack-mount and cable-management kit—Two rack-mount brackets, cable-management bracket, eight M4 x 6-mm Phillips flathead screws, four M3 x 6-mm Phillips panhead screws, and four 10/32 x 3/8-inch slotted binderhead screws</li> <li>• AC-input power cables—Up to two AC-input power cables (if separate AC-input power supply ordered)</li> <li>• Documentation, including the following: <ul style="list-style-type: none"> <li>– Cisco Information Packet</li> <li>– Cisco Network Registrar documentation—if ordered</li> <li>– Cisco IOS software documentation set—if ordered</li> </ul> </li> </ul> <p><b>Note</b> All hardware and software documentation is also found at the following URL:</p> <p><a href="http://www.cisco.com/en/US/products/hw/cable/ps2217/tsd_products_support_series_home.html">http://www.cisco.com/en/US/products/hw/cable/ps2217/tsd_products_support_series_home.html</a></p>	



## CHAPTER 3

# Installing the Cisco uBR7225VXR Router

---

This chapter explains how to install and connect a Cisco uBR7225VXR universal broadband router and contains the following sections:

- [Cisco uBR7225VXR Router Installation Checklist, page 3-1](#)
- [Cisco uBR7225VXR Router Chassis Rack-Mounting Options, page 3-2](#)
- [Installing the Brackets on the Chassis, page 3-7](#)
- [Installing the Chassis in a Workbench or Tabletop Environment, page 3-12](#)
- [Cabling, page 3-13](#)
- [Console and Auxiliary Port Connection Equipment, page 3-14](#)
- [Protective Grounding, page 3-16](#)
- [Connecting Power, page 3-16](#)
- [Powering On the Cisco uBR7225VXR Router, page 3-18](#)

## Cisco uBR7225VXR Router Installation Checklist

A rack-mount and cable-management kit is included in the shipping container. The rack-mount brackets in the kit are for mounting the Cisco uBR7225VXR in standard, 19-inch-wide, 4-post equipment racks or telco-type equipment racks. The rack-mount brackets are not suitable for use with other racks, such as 23-inch telco racks. The cable-management bracket is designed to relieve the strain on interface cables that are installed on cable interface line cards in a Cisco uBR7225VXR router.

If you are installing an equipment shelf or using mounting hardware other than that supplied with the chassis, review the guidelines in the “[Equipment Racks](#)” section on [page 2-15](#), then proceed to the “[Cisco uBR7225VXR Router Chassis Rack-Mounting Options](#)” section on [page 3-2](#).

If you do not plan to install your Cisco uBR7225VXR router in an equipment rack, proceed to the “[Installing the Chassis in a Workbench or Tabletop Environment](#)” section on [page 3-12](#).

To assist you with your installation and to provide a historical record of what was done, and by whom, use “[Cisco uBR7225VXR Router Installation Checklist](#)” section on [page 2](#). Make a copy of this checklist and indicate when each procedure or verification is completed. When the checklist is completed, place it in your site log (see [Appendix G, “Site Log”](#)) along with the other records for your new router.

**Table 3-1 Cisco uBR7225VXR Router Installation Checklist**

Task	Verified by	Date
Router and all accessories unpacked		
Types and numbers of interfaces verified		
Verify shipping container contents see the <a href="#">“Shipping Container Contents” section on page 2-9</a>		
Router mounted in rack (optional)		
Cable-management bracket installed (optional but recommended)		
Chassis properly grounded		
AC power cables connected to power sources and router; cables secured		
Captive installation screws on network processing engine checked		
Network interface cables and devices connected		
ASCII terminal attached to console port		
Console port set for 9600 baud, 8 data bits, no parity, and 1 stop bit (9600 8N1)		
System power turned on (Input OK LED is on)		
System boot complete		
Network processing engine and all cable interface line cards operational		
System ready for global and interface-specific configuration		

## Cisco uBR7225VXR Router Chassis Rack-Mounting Options

The chassis mounts to two rack posts with brackets that attach to either the front, middle, or rear sides of the chassis. The inside width between the posts or mounting strips (left and right) must be at least 17.5 inches (44.45 cm).

Some equipment racks provide a power strip along the length of one of the mounting strips. [Figure 3-1](#) shows a typical 4-post equipment rack with a power strip along one of the back posts. If your rack has this feature, consider the position of the strip when planning fastener points and ensure that you will be able to pull cable interface line card cables and other FRUs straight out of their respective slots.

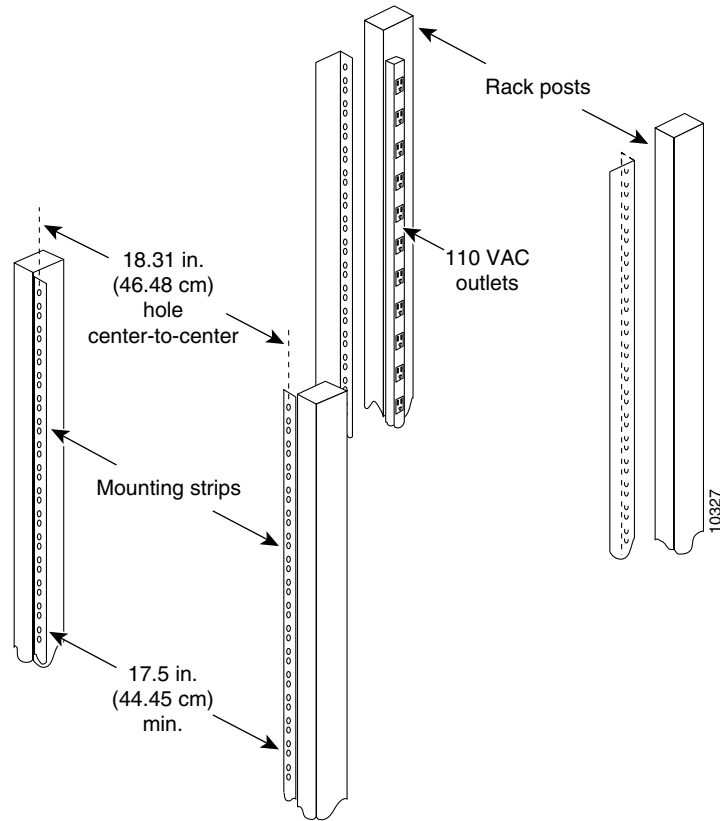
The inlet and exhaust ports for cooling air are located on the right and left of the chassis, respectively, so multiple universal broadband routers can be stacked in a rack with little or no vertical clearance.



### Note

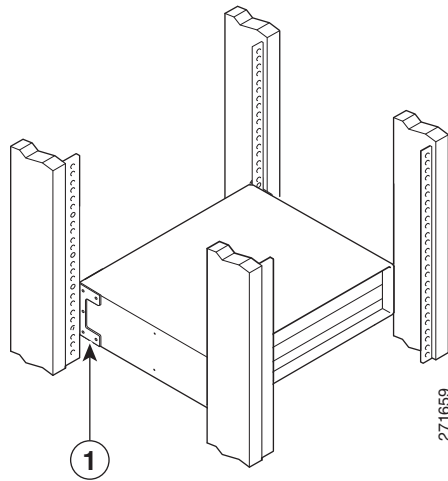
We recommend the rear bracket mounting system for 4-post racks. This method enables you to keep cables from protruding too far out in front of the Cisco uBR7225VXR router and to simultaneously manage the cables at the front of the chassis with the cable-management bracket.

**Figure 3-1 Typical 4-Post Equipment Rack Posts and Mounting Strips**



Mounting options are as follows:

- If you want the cable interface line card end (the front) of the chassis recessed in the rack, install the rack-mount brackets at the rear of the chassis in the orientation shown in [Figure 3-2 on page 3-4](#).
- If you want the front of the chassis mounted flush with the front posts of the rack, install the rack-mount brackets at the front of the chassis in the orientation shown in [Figure 3-3 on page 3-4](#).
- If you want the front of the chassis protruding out of the rack, install the rack-mount brackets at the front of the chassis in the orientation shown in [Figure 3-4 on page 3-5](#).
- If you want the chassis in a telco-type rack, install the rack-mount brackets in the middle of the chassis in the orientation shown in [Figure 3-5 on page 3-5](#).

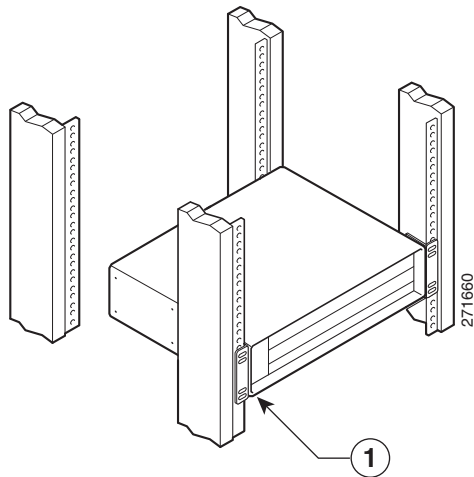
**Figure 3-2** *Installing the Chassis in a 4-Post Rack—Rear Installation*


---

**1** Rack-mount bracket
 

---

See the [“Installing Rack-Mount Brackets on the Rear of the Chassis”](#) section on page 3-7.

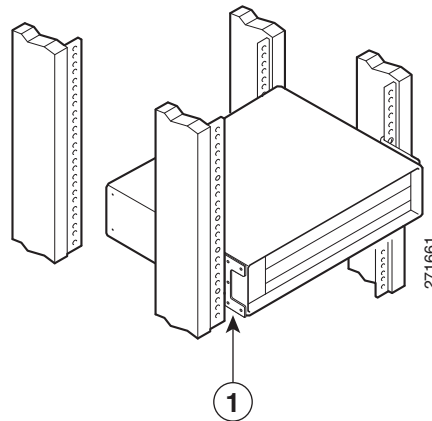
**Figure 3-3** *Installing the Chassis in a 4-Post Rack—Flush-Mounted Front Installation*


---

**1** Rack-mount bracket
 

---

See the [“Installing Rack-Mount Brackets on the Front of the Chassis”](#) section on page 3-8 for bracket mounting information.

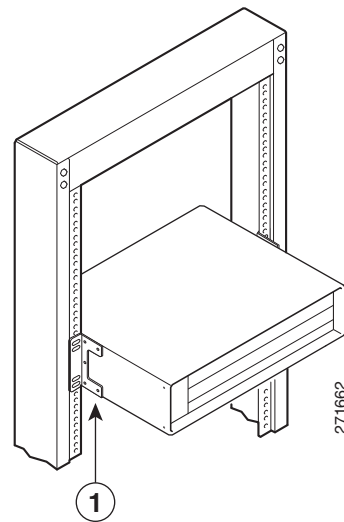
**Figure 3-4** Installing the Chassis in a 4-Post Rack—Chassis Protruding Front Installation


---

**1** Rack-mount bracket
 

---

See the “[Installing Rack-Mount Brackets in the Middle of the Chassis](#)” section on page 3-9 for bracket mounting information.

**Figure 3-5** Installing the Chassis in a Telco-Type Rack


---

**1** Rack-mount bracket
 

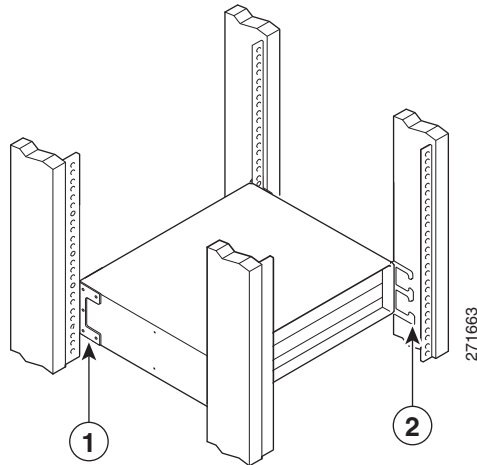
---

## Cable-Management Bracket Requirements

There are two cable-management bracket configurations available for rack-mounting the Cisco uBR7225VXR router. In the first configuration, for a 4-post rack, the rack-mount brackets are installed at the rear of the chassis and the cable-management bracket is installed at the right front of the chassis. (See [Figure 3-6](#).) You must install both sets of brackets before you install the chassis in the rack.

In the second configuration, for a telco-type rack, the rack-mount brackets are installed at the middle of the chassis and the cable-management bracket is installed at the right front of the chassis. (See [Figure 3-7](#).) You must install both sets of brackets before you install the chassis in the rack.

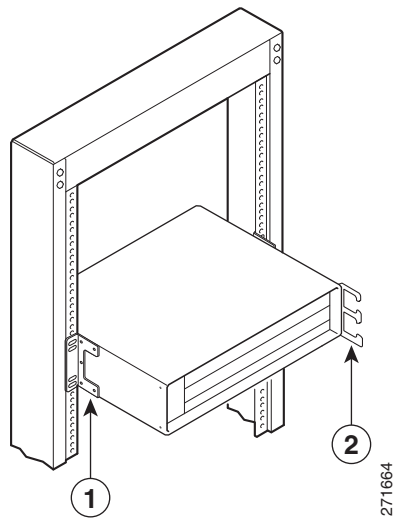
**Figure 3-6** *Installing the Chassis in a 4-Post Rack with an Installed Cable-Management Bracket*



**1** Rack-mount bracket

**2** Cable-management bracket

**Figure 3-7** *Installing the Chassis in a Telco-Type Rack with an Installed Cable-Management Bracket*



**1** Rack-mount bracket

**2** Cable-management bracket



## Installing the Brackets on the Chassis

This section explains how to install the rack-mount brackets and cable-management bracket on a Cisco uBR7225VXR universal broadband router. Before installing the chassis in the rack, you must install cable-management bracket and a rack-mount bracket on each side of the front, middle, or rear of the chassis.

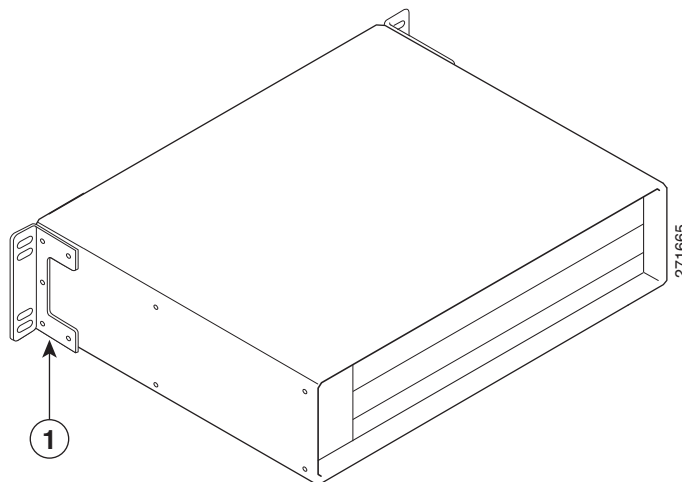
The parts and tools required for installing the rack-mount and cable-management bracket are listed in the “[Installation Tools](#)” section on page 2-8.

### Installing Rack-Mount Brackets on the Rear of the Chassis

To install the rack-mount brackets and cable-management bracket on the chassis for a rear rack-mount configuration, complete the following steps:

- 
- Step 1** Locate the threaded holes in the rear sides of the chassis.
  - Step 2** Align the first rack-mount bracket to the threaded holes in the right side of the chassis. See [Figure 3-8](#).

**Figure 3-8** *Installing the Rack-Mount Brackets on the Rear of the Chassis*




---

**1** Rack-mount bracket

---



**Note**

There are five holes in each of the rack-mount brackets for the Cisco uBR7225VXR router. Four holes are used for front and middle mount, and five holes are used for rear mount.

- Step 3** Thread five M4 x 6-mm Phillips flathead screws through the rack-mount bracket and into the side of the chassis. Use a number 2 Phillips screwdriver to tighten the screws.
- Step 4** Repeat [Step 1](#) through [Step 3](#) for the other rack-mount bracket.
- Step 5** If you plan to include the cable-management bracket in your rear rack-mount configuration, align the bracket with the two right front-side holes.

- Step 6** Thread two M3 x 6-mm Phillips panhead screws through the cable-management bracket and into the chassis, and tighten the screws.

This completes the procedure for installing the rack-mount brackets and the cable-management bracket on the chassis for a rear rack-mount configuration. Proceed to the “[Installing the Chassis in the Rack](#)” section on page 3-10.

**Caution**

To prevent injury, review the safety precautions in [Chapter 2, “Preparing the Cisco uBR7225VXR Router for Installation,”](#) before installing the Cisco uBR7225VXR router in a rack.

## Installing Rack-Mount Brackets on the Front of the Chassis

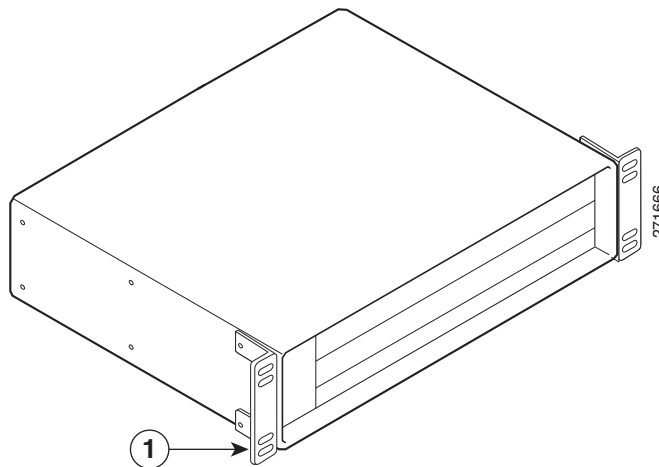
To install the rack-mount brackets and cable-management bracket on the chassis for a front rack-mount configuration, complete the following steps:

- Step 1** Locate the threaded holes in the front sides of the chassis.
- Step 2** If you want the front of the chassis flush with the front of the rack, align the first rack-mount bracket to the threaded holes in the right side of the chassis as shown in [Figure 3-9 on page 3-8](#).
- If you want the front of the chassis protruding from the rack, align the first rack-mount bracket to the threaded holes in the right side of the chassis as shown in [Figure 3-10 on page 3-9](#).

**Note**

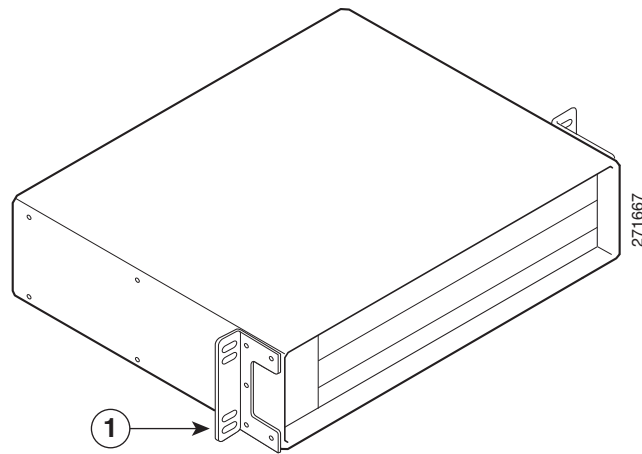
There are five holes in each of the rack-mount brackets for the Cisco uBR7225VXR. Four holes are used for front and middle mount, and five holes are used for rear mount.

**Figure 3-9** Installing the Rack-Mount Brackets so the Front of the Chassis Is Flush with the Rack



**1** Rack-mount bracket

**Figure 3-10** Installing the Rack-Mount Brackets so the Front of the Chassis Protrudes Out of the Rack



**1** Rack-mount bracket

- Step 3** Thread four M4 x 6-mm Phillips flathead screws through the rack-mount bracket and into the side of the chassis. Use a number 2 Phillips screwdriver to tighten the screws.
- Step 4** Repeat Step 1 through Step 3 for the other rack-mount bracket.
- Step 5** If you plan to include the cable-management bracket in your front rack-mount configuration, align the bracket with the two right front-side holes.
- Step 6** Thread two M3 x 6-mm Phillips panhead screws through the cable-management bracket and into the chassis, and tighten the screws.

This completes the procedure for installing the rack-mount brackets on the chassis for a front rack-mount configuration. Proceed to the [“Installing the Chassis in the Rack”](#) section on page 3-10.



**Caution**

To prevent injury, review the safety precautions in [Chapter 2, “Preparing the Cisco uBR7225VXR Router for Installation,”](#) before installing the universal broadband router in a rack.

## Installing Rack-Mount Brackets in the Middle of the Chassis

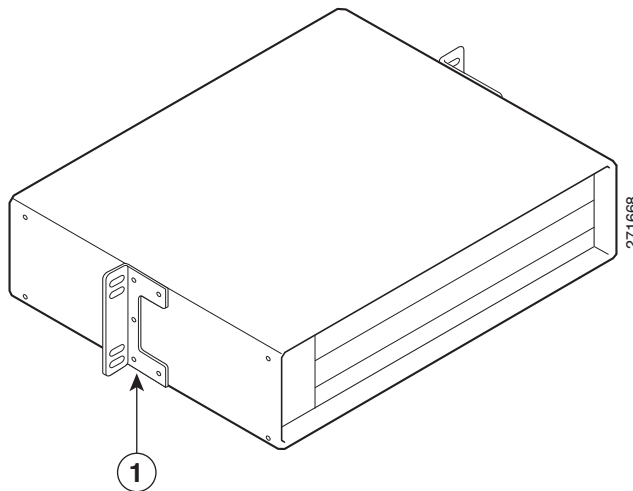
To install the rack-mount brackets and cable-management bracket at the middle of the chassis for a telco-type rack-mount configuration, complete the following steps:

- Step 1** Locate the threaded holes in the middle sides of the chassis.
- Step 2** Align the first rack-mount bracket to the threaded holes in the right side of the chassis. See [Figure 3-11](#).



**Note**

There are five holes in each of the rack-mount brackets for the Cisco uBR7225VXR router. Four holes are used for front and middle mount, and five holes are used for rear mount.

**Figure 3-11** Installing the Rack-Mount Brackets in the Middle of the Chassis for Telco-Type Racks


---

**1** Rack-mount bracket

---

- Step 3** Thread four M4 x 6-mm Phillips flathead screws through the rack-mount bracket and into the side of the chassis. Use a number 2 Phillips screwdriver to tighten the screws.
- Step 4** Repeat [Step 1](#) through [Step 3](#) for the other rack-mount bracket.
- Step 5** If you plan to include the cable-management bracket in your telco-type rack-mount configuration, align the bracket with the right front-side holes.
- Step 6** Thread two M3 x 6-mm Phillips panhead screws through the cable-management bracket and into the chassis, and tighten the screws.
- 

This completes the procedure for installing the rack-mount brackets and cable-management bracket on the Cisco uBR7225VXR router. Proceed to the following section, “[Installing the Chassis in the Rack.](#)”

**Caution**

To prevent injury, review the safety precautions in [Chapter 2, “Preparing the Cisco uBR7225VXR Router for Installation,”](#) before installing the Cisco uBR7225VXR router in a rack.

---

## Installing the Chassis in the Rack

After installing the brackets on the chassis, mount the chassis by securing the rack-mount brackets to the posts or mounting strips in the rack using the slotted screws provided.

**Note**

When installing the uBR7225VXR in a rack, ensure that paint is removed from the rack and an anti-oxidant is applied at the contact points to ensure reliable metal to metal contact.

---

**Caution**

Because the brackets support the weight of the entire chassis, be sure to use all of the required slotted screws to fasten the two rack-mount brackets to the rack posts. [Figure 3-2 on page 3-4](#), [Figure 3-3 on page 3-4](#), [Figure 3-4 on page 3-5](#), and [Figure 3-5 on page 3-5](#) show typical installations in 19-inch, four-post and telco-type equipment racks.

**Warning**

**Two people are required to lift the chassis. Grasp the chassis underneath the lower edge and lift with both hands. To prevent injury, keep your back straight and lift with your legs, not your back. To prevent damage to the chassis and components, never attempt to lift the chassis with the handles on the power supplies or on the interface processors, or by the plastic panels on the front of the chassis. These handles were not designed to support the weight of the chassis.** Statement 5

**Warning**

**To prevent bodily injury when mounting or servicing this unit in a rack, you must take special precautions to ensure that the system remains stable. The following guidelines are provided to ensure your safety:** Statement 1006

- This unit should be mounted at the bottom of the rack if it is the only unit in the rack.
- When mounting this unit in a partially filled rack, load the rack from the bottom to the top with the heaviest component at the bottom of the rack.
- If the rack is provided with stabilizing devices, install the stabilizers before mounting or servicing the unit in the rack.

To install the chassis in the rack, complete the following steps:

- Step 1** On the chassis, ensure that all captive installation screws on the network processing engine, each cable interface line card, and each power supply are tightened.
- Step 2** Make sure that your path to the rack is unobstructed. If the rack is on wheels, ensure that the brakes are engaged or that the rack is otherwise stabilized.

**Caution**

Two people should perform [Step 3](#) through [Step 6](#).

- Step 3** Position the chassis so that the front end is closest to you; then lift the chassis and move it to the rack. To prevent injury, avoid sudden twists or moves.
- Step 4** Slide the chassis into the rack, pushing it back until the brackets (installed at the front or rear of the chassis) meet the mounting strips or posts on both sides of the equipment rack.

**Note**

The rack-mount bracket must be placed behind the rack post or mounting strip in the rear installation configuration. (See [Figure 3-2 on page 3-4](#).)

- Step 5** While keeping the brackets flush against the posts or mounting strips, position the router so that the holes in the brackets are aligned with those in the mounting strips.

- Step 6** Insert the 10/32 x 3/8 slotted screws (two to a side) through the brackets and into the mounting strip (use the top and bottom bracket holes, shown in [Figure 3-2 on page 3-4](#), [Figure 3-3 on page 3-4](#), [Figure 3-4 on page 3-5](#), and [Figure 3-5 on page 3-5](#)). Using a 7/16-inch flat-blade screwdriver, tighten all the screws.

This completes the procedure for installing the chassis in the rack. Proceed to the “Cabling” section on [page 3-13](#) to continue the installation.

## Installing the Chassis in a Workbench or Tabletop Environment

The Cisco uBR7225VXR universal broadband router should already be in the area where you will install it, and your installation location should already be determined. If not, refer to the “Site Requirements” section on [page 2-5](#).

When installing the router on a workbench or tabletop, ensure that the surface is clean and in a safe location and that you have considered the following:

- The Cisco uBR7225VXR router requires at least 3 inches (7.72 cm) of clearance at the inlet and exhaust vents (the right and left sides of the router).
- The Cisco uBR7225VXR router should be installed off the floor. (Dust that accumulates on the floor can be drawn into the interior of the router by the cooling fans. Excessive dust inside the router can cause overtemperature conditions and component failures.)
- There must be approximately 23.25 inches (59.06 cm) of clearance at the front, and 19 inches (48.3 cm) at the back of the Cisco uBR7225VXR router for installing and replacing field-replaceable units (FRUs), or accessing network cables or equipment.
- Make sure that blank cable interface line card and blank power supply filler plates are installed in empty slots.
- The Cisco uBR7225VXR router will receive adequate ventilation (it is being installed in an enclosed cabinet where ventilation is adequate).
- If you plan to install the cable-management bracket on the front of the chassis, set aside the cable-management bracket and the four M3 x 6-mm Phillips panhead screws.



### Warning

**Do not stack the chassis on any other equipment. If the chassis falls, it can cause severe bodily injury and equipment damage.** Statement 48

Complete the following steps to install the Cisco uBR7225VXR router on a workbench or tabletop:

- Step 1** Remove any debris and dust from the tabletop or workbench, and the surrounding area. Also make sure that your path between the router and its new location is unobstructed.
- Step 2** On the chassis, ensure that all captive installation screws on the network processing engine, cable interface line cards, and each power supply are tightened.



### Warning

**Two people are required to lift the chassis. To prevent injury, keep your back straight and lift with your legs, not your back.** Statement 164

- Step 3** Add the five rubber feet supplied with the accessory kit to the base of the chassis. Five indented circles are provided on the base of the chassis to indicate the location to which the rubber feet can be added.
- Step 4** Place the Cisco uBR7225VXR router on the tabletop or workbench.
- Step 5** Ensure that there is the appropriate amount of space around the router.
- 

If you want to install a cable-management bracket on the Cisco uBR7225VXR router, proceed to the following section, “[Installing the Cable-Management Bracket on a Cisco uBR7225VXR Router in a Workbench or Tabletop Environment](#).” Otherwise, proceed to the “[Cabling](#)” section on page 3-13.

## Installing the Cable-Management Bracket on a Cisco uBR7225VXR Router in a Workbench or Tabletop Environment

To install the cable-management bracket on a Cisco uBR7225VXR universal broadband router installed on a workbench or tabletop, complete the following steps:

- Step 1** Locate the threaded holes in the right front side of the chassis.
- Step 2** Align the cable-management bracket with the two threaded holes on the front or rear side of the Cisco uBR7225VXR chassis. (See [Figure 3-7 on page 3-6](#).)
- Step 3** Thread two M3 x 6-mm Phillips panhead screws through the bracket and into the chassis. Use a number 2 Phillips screwdriver to tighten the screws.
- 

This completes the steps for installing the cable-management bracket on the Cisco uBR7225VXR router. Proceed to, “[Cabling](#)” section on page 3-13 to continue the installation.

## Cabling

This section provides information on connecting cable interface cards, auxiliary and console ports to your Cisco uBR7225VXR universal broadband router.



Warning

**This product is not intended to be directly connected to the Cable Distribution System. Additional regulatory compliance and legal requirements may apply for direct connection to the Cable Distribution System. This product may connect to the Cable Distribution System ONLY through a device that is approved for direct connection.** Statement 1078

---



Warning

**The intra-building port(s) of the equipment or subassembly is suitable for connection to intra-building or unexposed wiring or cabling only. The intra-building port(s) of the equipment or subassembly MUST NOT metallurgically connect to interfaces that connect to the OSP or its wiring. These interfaces are designed for use as intra-building interfaces only (Type 2 or Type 4 ports as described in GR-1089-CORE, Issue 4) and require isolation from the exposed OSP cabling. The addition of Primary Protectors is not sufficient protection in order to connect these interfaces metallurgically to OSP wiring.** Statement 7005

---

**Caution**

To comply with GR-1089-Core intra-building lightning-immunity requirements, you must use shielded (screened) cable that is grounded at both ends.

## Connecting Cable Interface Line Card Cables

The instructions for connecting the cables for each cable interface line card installed in the Cisco uBR7225VXR universal broadband router are contained in the cable interface line card installation document. Refer to the *Cisco uBR7200 Series Interface Line Card Hardware Installation Guide* at the following URL:

[http://www.cisco.com/en/US/docs/interfaces\\_modules/cable/line\\_cards/installation/guide/mcxfu.html](http://www.cisco.com/en/US/docs/interfaces_modules/cable/line_cards/installation/guide/mcxfu.html)

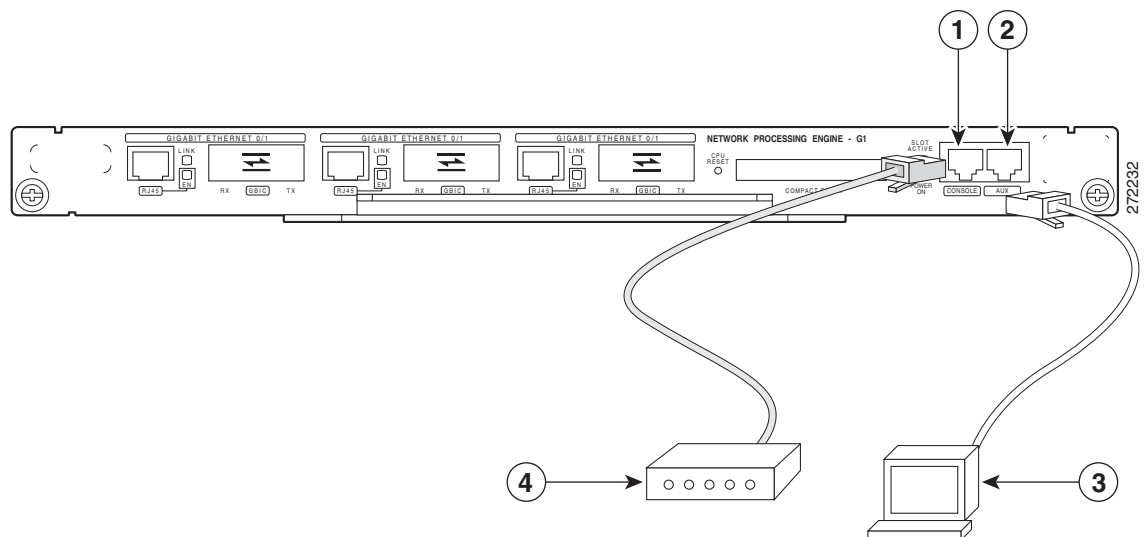
## Console and Auxiliary Port Connection Equipment

The NPE contains the console and auxiliary ports. The console port is a RJ-45 receptacle for connecting a data terminal, which you use to configure the interfaces and bring up the Cisco uBR7255VXR router. The auxiliary port is a RJ-45 receptacle for connecting a modem or the other DCE device (such as a channel service unit/data service unit [CSU/DSU]) to the router. (See [Figure 3-12 on page 3-14.](#))

**Note**

Both the console and auxiliary ports are asynchronous ports; any devices connected to these ports must be capable of asynchronous transmission. (Asynchronous is the most common type of serial device; for example, most modems are asynchronous devices.)

**Figure 3-12 Console and Auxiliary Port Connections**



1	Console port	3	Console terminal
2	Auxiliary port	4	Modem



Before connecting a terminal to the console port, configure the terminal to match the Cisco uBR7225VXR router console port as follows:

- 9600 baud
- 8 data bits
- No parity
- 1 stop bit (9600 8N1)

You need an RJ-45 console cable to connect the terminal to the console port. After you establish normal universal broadband router operation, you can disconnect the terminal.

You must supply your own interface cable between the auxiliary port and the equipment you are connecting. For console and auxiliary port pinouts, refer to the “[Console Port Signals](#)” section on page 3-15 and the “[Auxiliary Port Signals](#)” section on page 3-15.

## Console Port Signals

Both Data Set Ready (DSR) and Data Carrier Detect (DCD) signals are active when the system is running. The Request To Send (RTS) signal tracks the state of the Clear To Send (CTS) input. The console port does not support modem control or hardware flow control. [Table 3-2](#) lists the signals used on the console port. The console port requires a straight-through EIA/TIA-232 cable.

**Table 3-2 Console Port Signal**

Pin	Signal	Direction	Description
1	GND	–	Ground
2	TxD	<—	Transmit Data
3	RxD	—>	Receive Data
6	DSR	—>	Data Set Ready (always on)
7	GND	–	Ground
8	DCD	—>	Data Carrier Detect (always on)

## Auxiliary Port Signals

[Table 3-3](#) lists the signals used on the auxiliary port. The auxiliary port supports hardware flow control and modem control.

**Table 3-3 Auxiliary Port Signals**

Pin	Signal	Direction	Description
2	TxD	—>	Transmit Data
3	RxD	<—	Receive Data
4	RTS	—>	Request To Send (used for hardware flow control)
5	CTS	<—	Clear To Send (used for hardware flow control)
6	DSR	<—	Data Set Ready
7	Signal Ground	–	Signal Ground

**Table 3-3** Auxiliary Port Signals

Pin	Signal	Direction	Description
8	CD	←	Carrier Detect (used for modem control)
20	DTR	→	Data Terminal Ready (used for modem control only)

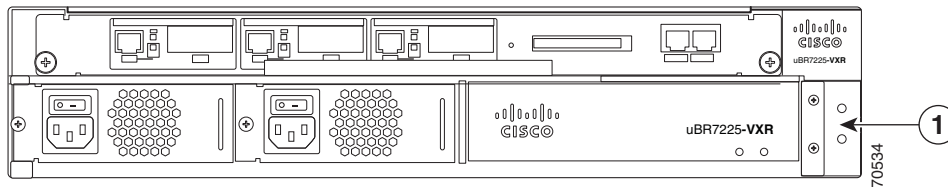
## Protective Grounding

The building installation should provide a means for connection to the protective earth grounding. The equipment should be connected to that means.


**Note**

The uBR7225VXR is intended for installation in a Common Bonding Network (CBN).

While installing the equipment, the service person should check whether the power source is adequately grounded. If it is not, the service person should arrange for the installation of a protective grounding conductor from the equipment to the protective grounding wire in the building. This conductor should consist of a minimum #6 American Wire Gauge (AWG) stranded copper wire. See [Figure 3-13](#) to identify the ground lug location.

**Figure 3-13** Cisco uBR7225VXR Ground Lug Location

1 Ground lug location

## Connecting Power

Following are the procedures for connecting AC-input power to your Cisco uBR7225VXR universal broadband router.


**Warning**

**High leakage current - earth connection essential before connecting to system power supply.**

Statement 342


**Warning**

**Care must be given to connecting units to the supply circuit so that wiring is not overloaded.**

Statement 1018


**Warning**

**Read the installation instructions before you connect the system to its power source.**

Statement 1004

**Warning**

**Before working on equipment that is connected to power lines, remove jewelry (including rings, necklaces, and watches). Metal objects will heat up when connected to power and ground and can cause serious burns or weld the metal object to the terminals.** Statement 43

**Warning**

**This equipment is intended to be grounded to comply with emission and immunity requirements. Ensure that the switch functional ground lug is connected to earth ground during normal use.** Statement 1064

**Warning**

**This equipment must be grounded. Never defeat the ground conductor or operate the equipment in the absence of a suitably installed ground conductor. Contact the appropriate electrical inspection authority or an electrician if you are uncertain that suitable grounding is available.** Statement 1024

**Note**

Detailed instructions for handling and replacing the Cisco uBR7225VXR router power supplies are contained in the *Cisco uBR7200 Series Universal Broadband Router AC-Input Power Supply Replacement Instructions* at the following URL:  
<http://www.cisco.com/en/US/docs/cable/cmts/ubr7200/installation/4848pwra.html>

## Connecting to the AC-Input Power Supply

**Warning**

**The device is designed to work with TN power systems.** Statement 19

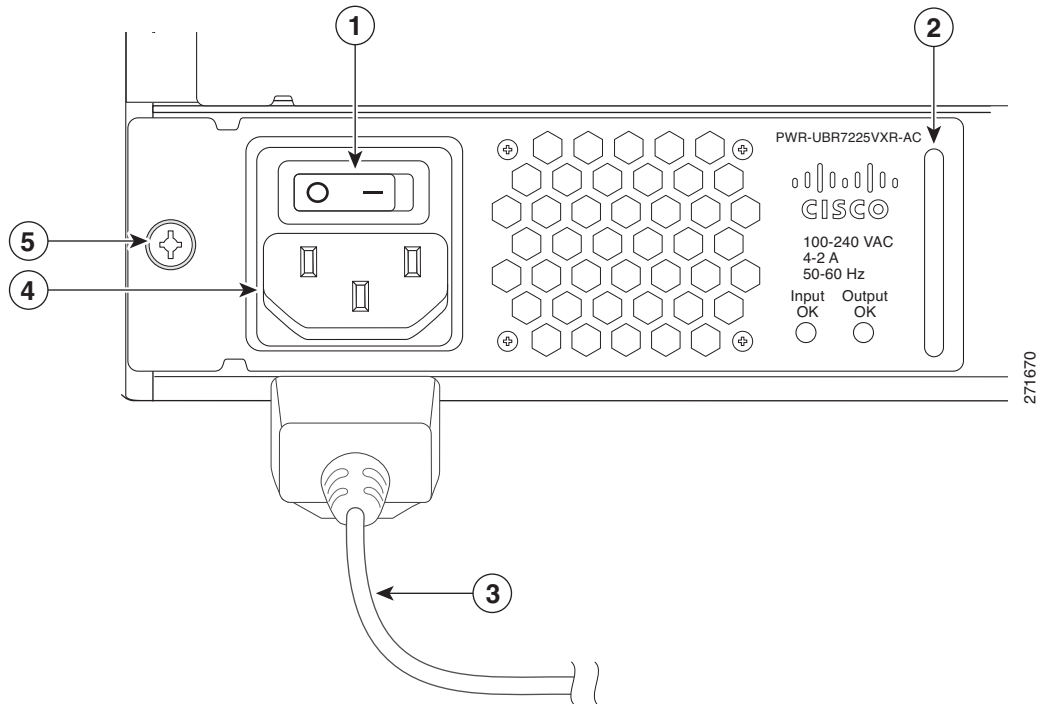
**Note**

A certified external Surge Protective Device (SPD) is used at the AC-input of the Cisco uBR7225VXR universal broadband router.

To connect to the AC-input power supply:

- Step 1** At the rear of the Cisco uBR7225VXR universal broadband router, ensure that the power switch on the power supply is in the **off** (0) position.
- Step 2** Plug in the power cable.

Figure 3-14 Connecting AC-Input Power



1	Power switch	4	Power receptacle
2	Handle	5	Captive installation screw
3	AC power cable		

**Step 3** Plug the AC power supply cable into the AC power source.

**Step 4** Repeat Step 1 through Step 3 for the second power supply (if present).

This completes the procedure for connecting AC-input power. Proceed to the [“Powering On the Cisco uBR7225VXR Router”](#) section on page 3-18.

## Powering On the Cisco uBR7225VXR Router

After installing your Cisco uBR7225VXR universal broadband router and connecting cables, power on the universal broadband router as follows:

**Step 1** Check for the following:

- Each cable interface line card is inserted in its slot and its captive installation screws are tightened.
- The network processing engine is inserted in to its slot and the captive installation screws are tightened.

**Note**

If the cable interface line card or the network processing engine is not properly seated or not fully locked into place, the Cisco uBR7225VXR router might enter a continuous restart loop. Make sure that the boards are seated and locked into position.

- Hybrid fiber-coaxial (HFC) network coaxial cable is connected to the cable interface line cards.
- A CompactFlash Disk is installed in a CompactFlash Disk slot in the front panel of the NPE-G1 or NPE-G2. Use only authorized Cisco provided CompactFlash Disks.
- Each AC-input power cable is connected.
- The console terminal is turned on.

**Step 2** At the rear of the Cisco uBR7225VXR router, place the power switch on the power supply in the **on** (I) position. Repeat this step if a second power supply is installed. The power supply OK LEDs comes on.

**Step 3** Listen for the fans; you should immediately hear them operating. In a very noisy environment, also look for air movement around the chassis to verify that the fans are operating. If the Cisco uBR7225VXR router was recently switched off, it might take up to 90 seconds for the power supply to restart and the fans to start operating.

**Note**

To facilitate headend installation, a Cisco uBR7225VXR universal broadband router equipped with at least one cable interface line card generates a downstream IF carrier when it starts running.

The downstream IF carrier will be present if a cable interface line card is properly installed and passes diagnostics, the router has been powered on for more than two minutes, the IF downstream shutdown command (**no cable downstream if-output**) has not been configured, or the Cisco uBR7225VXR router is not in ROMMON mode. The amplitude and shape of the downstream IF carrier will not change after the Cisco uBR7225VXR router is configured, unless a non-DOCSIS data rate is configured.

**Step 4** Observe the initialization process. When the system boot is complete (a few seconds), the network processing engine begins to initialize the cable interface line cards. During this initialization, the LEDs on each cable interface line card behave differently (most flash on and off). The enabled LED on each cable interface line card goes on when initialization is complete, and the console screen displays a script and system banner similar to the following:

```
Cisco IOS Software, 7200 Software (UBR7200-K9PU2-M), Version 12.2(33)SCA, RELEASE SOFTWARE
(fc1)
Technical Support: http://www.cisco.com/techsupport
Copyright (c) 1986-2008 by Cisco Systems, Inc.
Compiled Thu 14-Feb-08 13:58 by prod_rel_team
```

## Configuring the Interfaces

When you start up the Cisco uBR7225VXR router for the first time, the system automatically enters the setup facility (also called the system configuration dialog), which determines which cable interface cards are installed. The setup facility prompts you for configuration information.

On the console terminal, after the system displays the system banner and hardware configuration, the following System Configuration Dialog prompt appears:

```
--- System Configuration Dialog ---
```

At any point you may enter a questions mark '?' for help.  
Use ctrl-c to abort configuration dialof at any prompt.  
Default settings are in square brackets '['].

continue with configuration dialog? [yes]:

You can proceed with the setup facility or exit from the setup facility, using the command interface to configure global (system-wide) and interface-specific parameters.

**Caution**

The setup facility currently excludes cable-specific configuration commands. Upstream ports, therefore, have a default state of “shutdown” after the setup facility is run. You must configure upstream parameters. For additional information, refer to the *Cisco uBR7200 Series Software Configuration Guide* at the following URL:

<http://www.cisco.com/en/US/docs/cable/cmts/ubr7200/configuration/guide/cr72scg.html>

You do not have to configure the interfaces immediately; however, you cannot enable the interfaces or connect them to any networks until you have configured them.

Many of the cable interface line card LEDs do not come on until you have configured the interfaces. To verify correct operation of each interface, complete the first-time startup procedures and configuration, then refer to the document for each cable interface line card for LED descriptions and to check the status of the interfaces.

Your Cisco uBR7225VXR chassis installation is complete. To set up your cable network headend, proceed to [Chapter 4, “Connecting the Cisco uBR7225VXR Router to the Cable Headend.”](#) To begin configuring your Cisco uBR7225VXR router, see the *Cisco uBR7200 Series Software Configuration Guide* at the following URL:

<http://www.cisco.com/en/US/docs/cable/cmts/ubr7200/configuration/guide/cr72scg.html>



## CHAPTER 4

# Connecting the Cisco uBR7225VXR Router to the Cable Headend

---

This chapter describes how to connect the Cisco uBR7225VXR universal broadband router to a cable headend and contains the following sections:

- [Two-Way Data Headend Architecture, page 4-2](#)
- [One-Way Data Headend Architecture, page 4-3](#)
- [RF and Digital Data Overview, page 4-3](#)
- [Connecting and Configuring the Downstream, page 4-4](#)
- [Measuring the Downstream RF Signal, page 4-4](#)
- [Connecting and Configuring the Upstream, page 4-18](#)
- [Measuring the Upstream RF Signal, page 4-22](#)
- [Measuring the RF Signal at the Forward Test Point on a Laser Transmitter, page 4-37](#)
- [Configuring the Digital Signal, page 4-40](#)



### Note

---

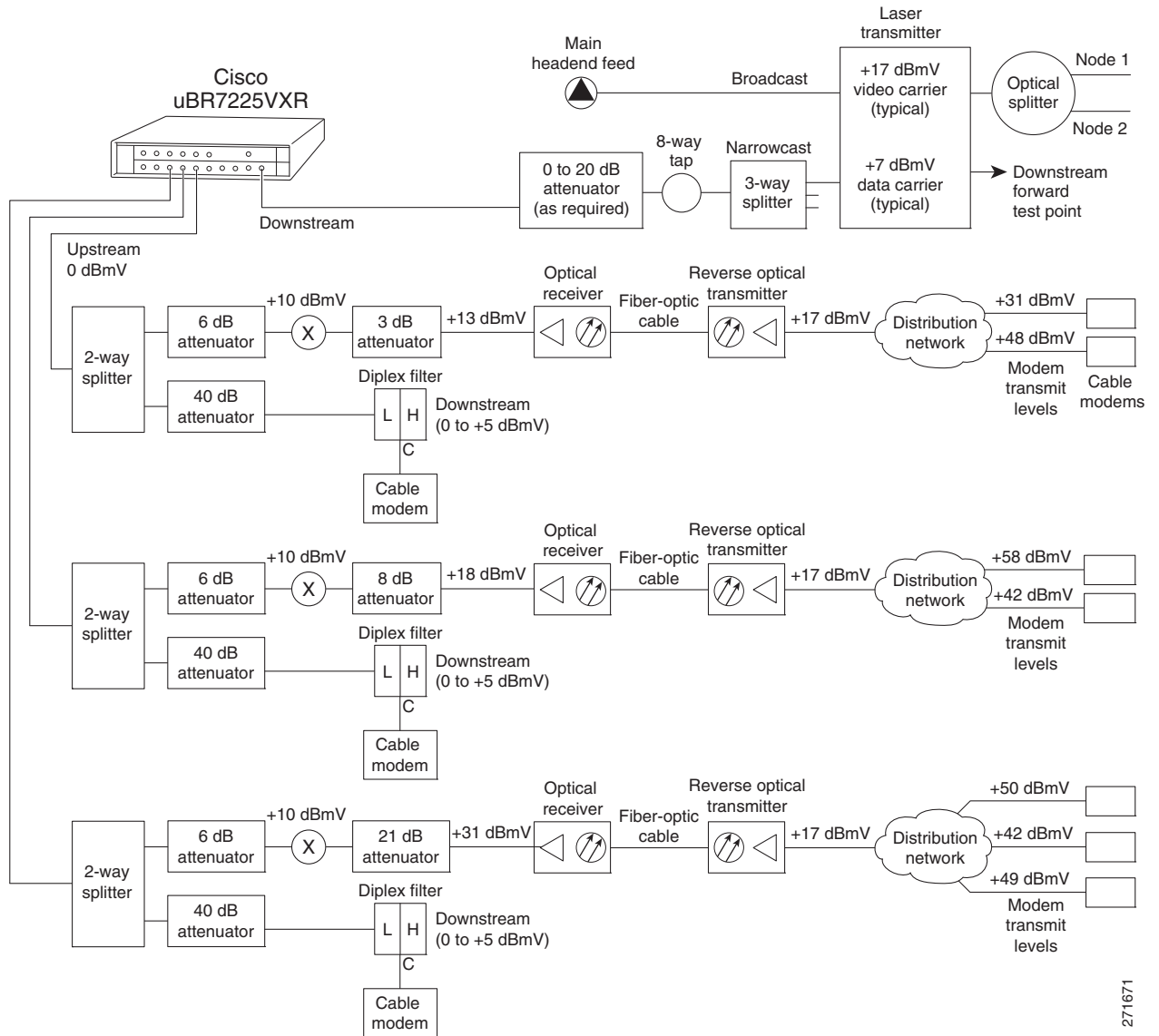
Before installing your Cisco uBR7225VXR router, analyze the radio frequency (RF) setup at your headend and configure the analog RF signals for interaction with digital data. This chapter guides you through the process of configuring the RF and digital data at the headend for optimal performance.

---

# Two-Way Data Headend Architecture

Figure 4-1 shows a typical headend configuration configured for two-way data, including digitized voice and fax.

Figure 4-1 Typical Cable Headend Configuration for Two-Way Data



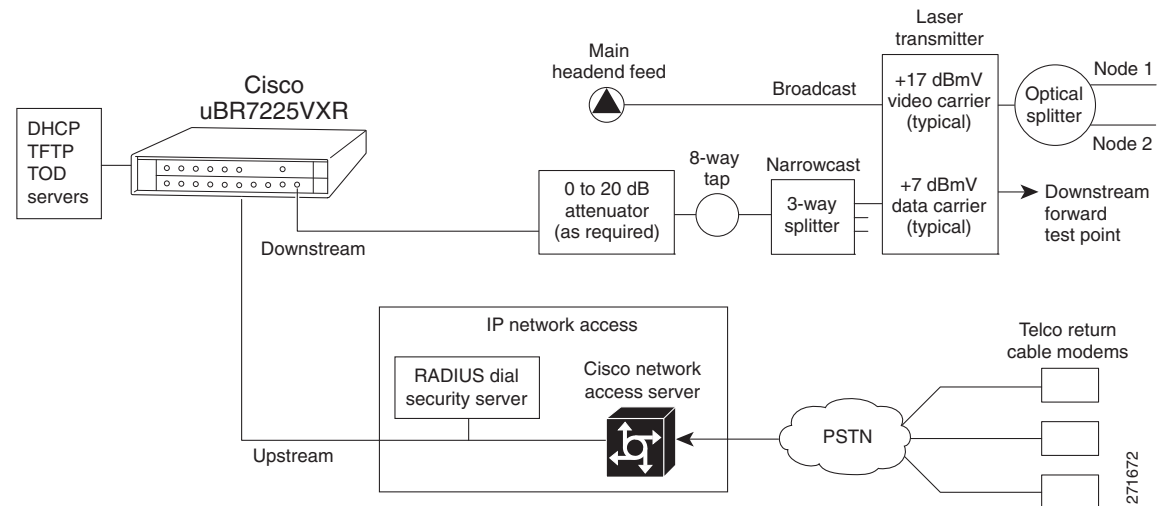
271671



# One-Way Data Headend Architecture

Figure 4-2 shows a typical headend configuration configured for one-way (downstream) data in a telco return cable system.

**Figure 4-2** Typical Cable Headend Configuration for One-Way (Telco Return) Data



## RF and Digital Data Overview

This section describes the interaction of digital and analog RF data as both signals are carried on the hybrid fiber-coaxial (HFC) network.

Two-way digital data signals are more susceptible than one-way signals to stresses in the condition of the HFC network. Degradation in video signal quality might not be noticed, but when two-way digital signals share the network with video signals, digital signals might be hampered by the following types of network impairments:

- **Impulse and electrical noise**—Impulse and electrical noise, usually forms of ingress, can enter the network from sources within a home, such as hair dryers, light switches, and thermostats; or from high-voltage lines that run near CATV cabling in the network. Areas of signal ingress may be located and repaired by implementing a comprehensive signal leakage maintenance program.
- **Amplifier thermal noise**—Amplifiers add noise to the HFC network that usually goes unnoticed in video signals, assuming a properly designed and operated network. Improperly configured amplifiers will degrade digital data signals. The larger the network, the higher the probability of amplifier thermal noise affecting the signals.
- **Ingress noise**—Ingress noise includes electrical sources (see “Impulse and electrical noise” above); amateur radio transmissions; citizens band radios; or high-power shortwave broadcast signals, which can interfere with frequencies anywhere between 3 and 65 MHz. These often are picked up by cabling and equipment in the network.



### Note

Some HFC upstream equipment passes interfering signals below 5 MHz, which may overload the reverse path.

- Noise funneling—The upstream data path to the headend is susceptible to picking up noise and interference from anywhere in the network, and all upstream noise ultimately ends up at the headend. This effect is known as *noise funneling* because of the cumulative nature of the noise from one or more locations in the network that becomes concentrated at the headend. As a network serviced by a single upstream receiver increases in size, the probability of noise funneling also increases.
- Variable transmit levels—Signal loss over coaxial cable is affected by temperature. This can cause variations of 6 to 10 dB per year.
- Clipping—The lasers in fiber-optic transmitters can stop transmitting light (clipping) when input levels are excessive. Excessive input levels may cause bit errors and reduced data throughput in both the upstream and downstream transmissions. If a laser is overdriven as briefly as a fraction of a second, clipping can occur.

## Connecting and Configuring the Downstream

After you install the Cisco uBR7225VXR universal broadband router in your headend site, you must connect the Cisco uBR7225VXR router to the HFC network and configure the network. The following sections describe how to connect to and configure the downstream.

### Installing and Configuring the Upconverter

The Cisco uBR-MC16U/E-16U and Cisco uBR-MC28U/E-28U cable interface line cards have an onboard integrated upconverter that generates an RF signal suitable for connection to a combiner and transmission on the coaxial cable network, without the need for any external upconverters.



#### Note

For more information, refer to the *Cisco uBR7200 Series Cable Interface Line Card Hardware Installation Guide* at the following URL:

[http://www.cisco.com/en/US/docs/interfaces\\_modules/cable/line\\_cards/installation/guide/mcxfu.html](http://www.cisco.com/en/US/docs/interfaces_modules/cable/line_cards/installation/guide/mcxfu.html)

## Measuring the Downstream RF Signal

The configuration of the downstream digitally modulated carrier at the headend is critical to the performance of the Cisco uBR7225VXR universal broadband router and cable modems. The following guidelines are provided to assist you in configuring the RF signal to the necessary specifications. There are two options you can use to measure the RF signal with a spectrum analyzer. These options are described in the following sections:

- [Measuring the Downstream RF Signal Using the Channel Power Option on a Spectrum Analyzer, page 4-5](#)
- [Measuring the Downstream RF Signal Using CATV Mode on a Spectrum Analyzer, page 4-11 \(equipped with digital channel power mode\)](#)

These two sections describe the procedures necessary to use a spectrum analyzer. You may also use a signal level meter that has the ability to measure the average power level of digitally modulated carriers, as well as a QAM analyzer. Some instruments to perform these measurements include:

- Acterna SDA-5000 w/Option 4 (<http://www.acterna.com>)
- Agilent 8591C, N1776A, 2010 or 3010 (<http://www.tm.agilent.com>)
- Sunrise Telecom AT-2000RQ, CM1000 or CR1200R (<http://www.sunrisetelecom.com>)
- Telsey DMA-120, DMA-121 or DMA122 (<http://www.telsey.it>)
- Trilithic 860DSP w/Option QA1 (<http://www.trilithic.com>)

If you complete these measurements using one of the previously mentioned options, your downstream signal can be verified as correctly configured and it can assist you with troubleshooting your network later on.

If you want to measure the downstream RF signal using the spectrum analyzer channel power option, proceed to the following section, “[Measuring the Downstream RF Signal Using the Channel Power Option on a Spectrum Analyzer](#).” If you want to measure the downstream RF signal using CATV mode, proceed to the “[Measuring the Downstream RF Signal Using CATV Mode on a Spectrum Analyzer](#)” section on page 4-11.

## Measuring the Downstream RF Signal Using the Channel Power Option on a Spectrum Analyzer

The following sections describe how to measure the downstream RF signal using the channel power option on a spectrum analyzer:

- [Measuring the Downstream IF Signal at the Cisco uBR7225VXR Router](#), page 4-5
- [Measuring the Downstream RF Signal at the Upconverter Output](#), page 4-7

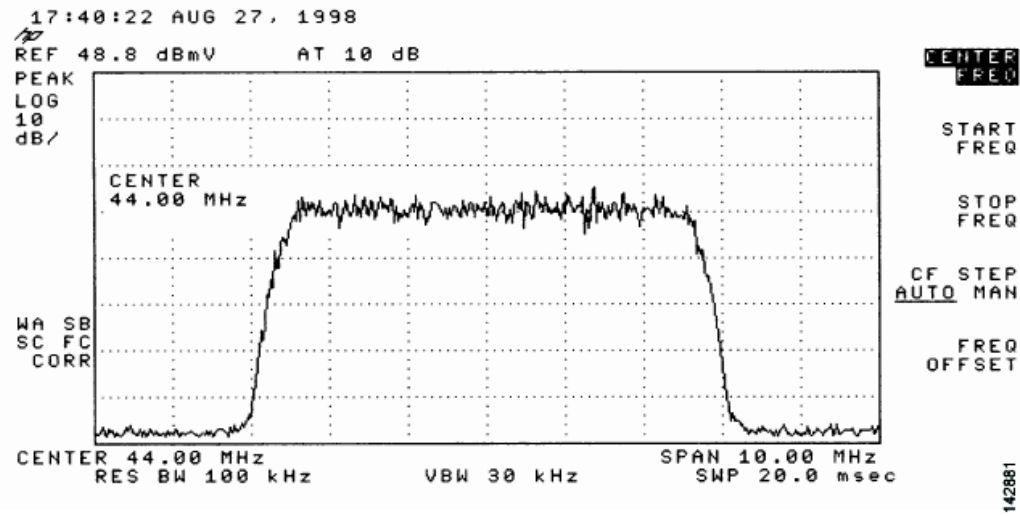
### Measuring the Downstream IF Signal at the Cisco uBR7225VXR Router

**Note**

Refer to the user guide that accompanied your spectrum analyzer to determine the exact steps required to use your analyzer to perform these measurements.

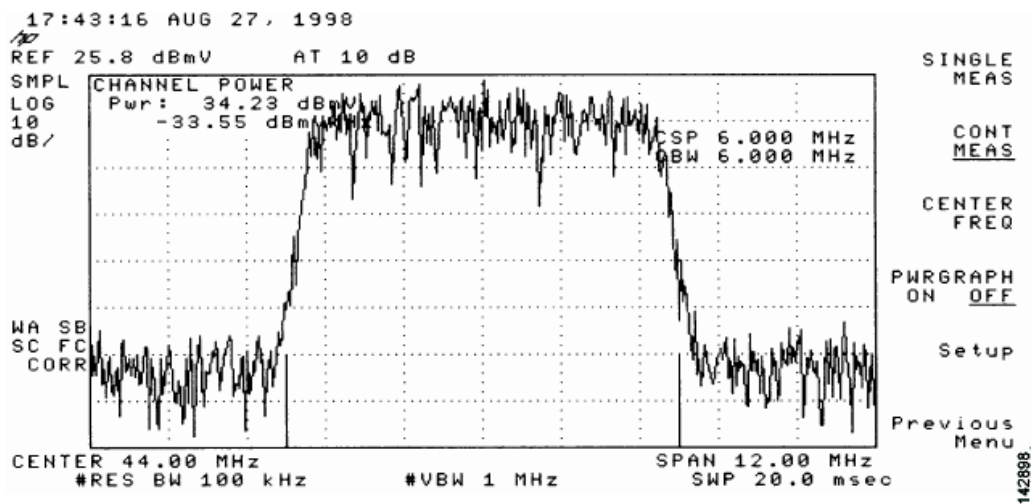
- 
- Step 1** Connect a spectrum analyzer to the downstream connector on a Cisco cable interface line card installed in a Cisco uBR7225VXR router.
  - Step 2** Turn the power switch on the spectrum analyzer to the ON position.
  - Step 3** Set the spectrum analyzer to view the downstream intermediate frequency (IF) signal with a center frequency of 44 MHz for a North American headend or 36.125 MHz for a European headend.
  - Step 4** Set the span to 10 MHz. Your analyzer should display a signal similar to the one shown in [Figure 4-3](#).

Figure 4-3 Viewing the Downstream IF Signal on a Spectrum Analyzer



- Step 5** Measure the IF signal using the channel power option on your spectrum analyzer. Set your channel spacing and your channel bandwidth to 6 MHz. Your analyzer should display a signal similar to the one shown in Figure 4-4.

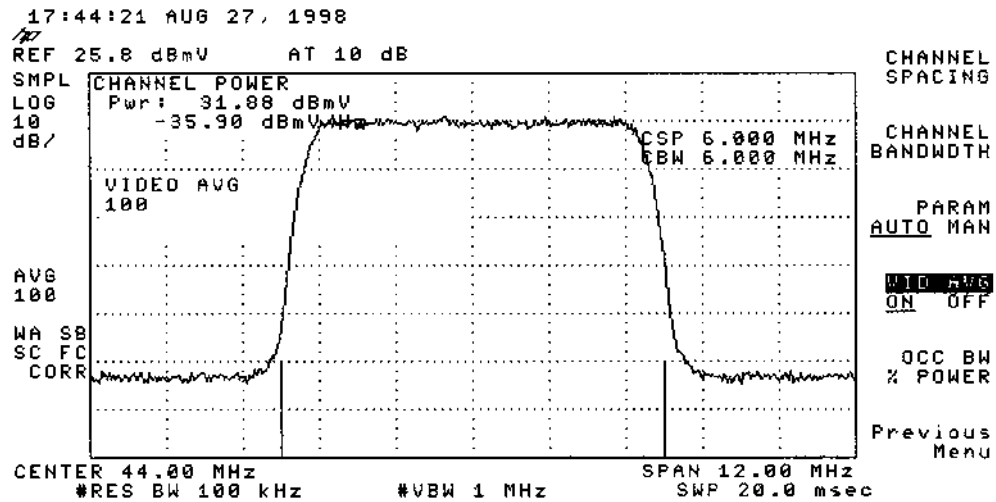
Figure 4-4 Measuring the IF Channel Power

**Note**

The IF channel power in Figure 4-4 is +34.23 dBmV, as displayed on the spectrum analyzer.

- Step 6** Select the video averaging feature. Your spectrum analyzer should display a signal similar to the one shown in Figure 4-5.

Figure 4-5 Measuring the IF Channel Power Using Video Averaging

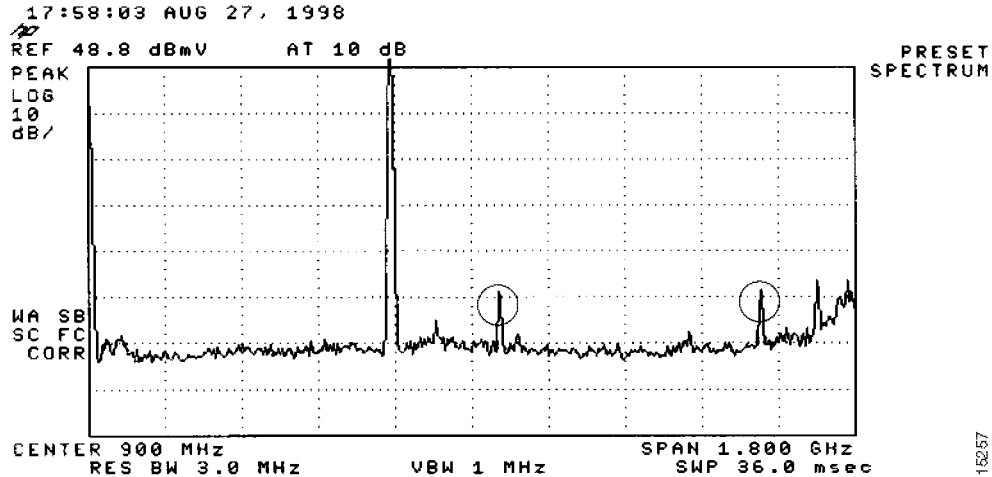
**Note**

The approximate in-channel peak-to-valley flatness may be verified using the spectrum analyzer's video averaging feature. Be aware, however, that amplitude values registered while in the video averaging mode are typically around 2.5 dB below the actual channel power.

## Measuring the Downstream RF Signal at the Upconverter Output

- Step 1** Disconnect the spectrum analyzer from the cable interface line card downstream connector.
- Step 2** Connect the downstream output of the cable interface line card to the upconverter input connector.
- Step 3** Connect the spectrum analyzer to the RF output of the upconverter. If your spectrum analyzer input is overloaded, you might see artifacts that are internally generated by the spectrum analyzer. The artifacts are circled on the analyzer trace shown in [Figure 4-6](#). Add attenuation as necessary to correct the overload condition.

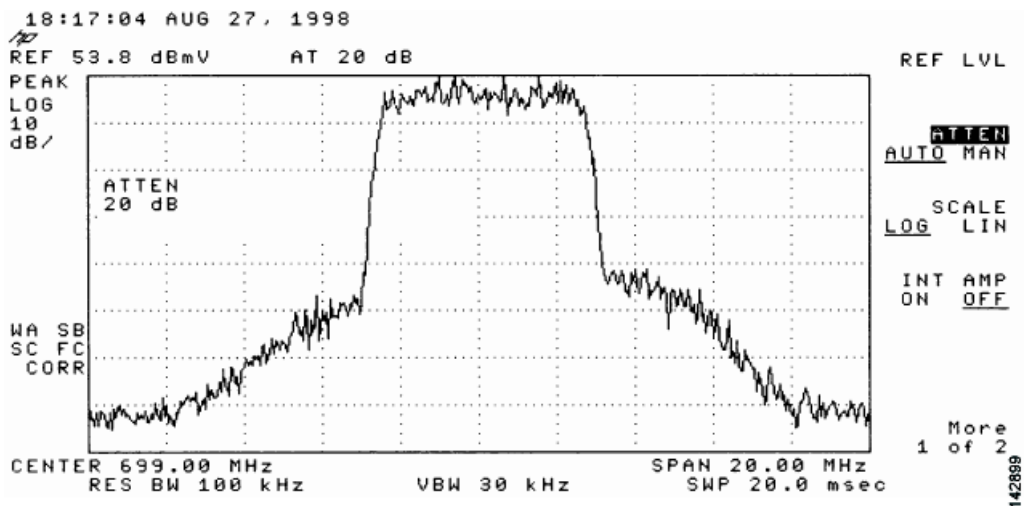
Figure 4-6 Overloaded Spectrum Analyzer Input



- Step 4** Set the input of the upconverter to a digital QAM signal and the output level to the manufacturer's recommended settings. Typical output amplitudes range from +50 to +58 dBmV, although DOCSIS specifies +61 dBmV.
- Step 5** Set the spectrum analyzer to view the RF signal at the center frequency you selected for your headend. In this example, the RF center frequency is 699 MHz. Set your span to 20 MHz. Finally, set your channel spacing and your channel bandwidth to 6 MHz.

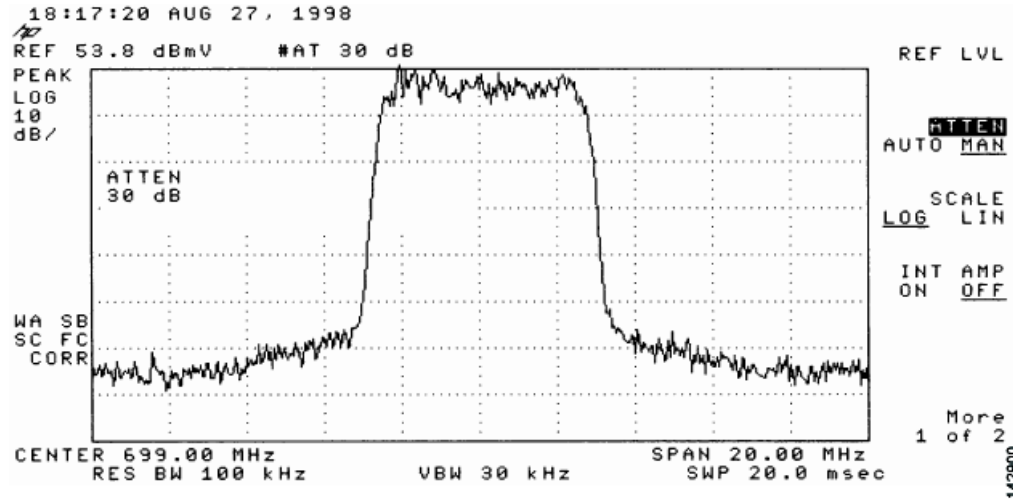
If the RF signal is causing an overload condition on the spectrum analyzer input, your analyzer might display a signal similar to the one shown in Figure 4-7. The sloping of the lines at the sides of the signal indicate a false reading.

Figure 4-7 Measuring the RF Signal at the Upconverter Output—Overload Condition



- Step 6** If you add attenuation to the input to the spectrum analyzer you can correct the overload condition as shown in Figure 4-8.

**Figure 4-8** Measuring the RF Signal at the Upconverter Output—Overload Condition Corrected with Attenuation



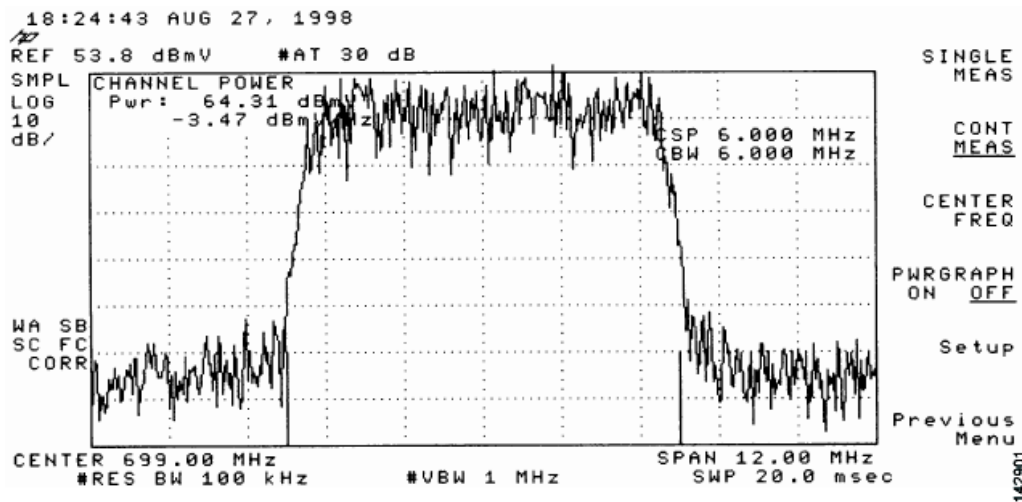
- Step 7** Change the spectrum analyzer settings to view the digital channel power. This setting enables you to see if there is too much power on the upconverter output. In [Figure 4-9](#), the upconverter output is reading +64.31 dBmV, which is beyond the DOCSIS-specified range of +50 to +61 dBmV.



**Tip**

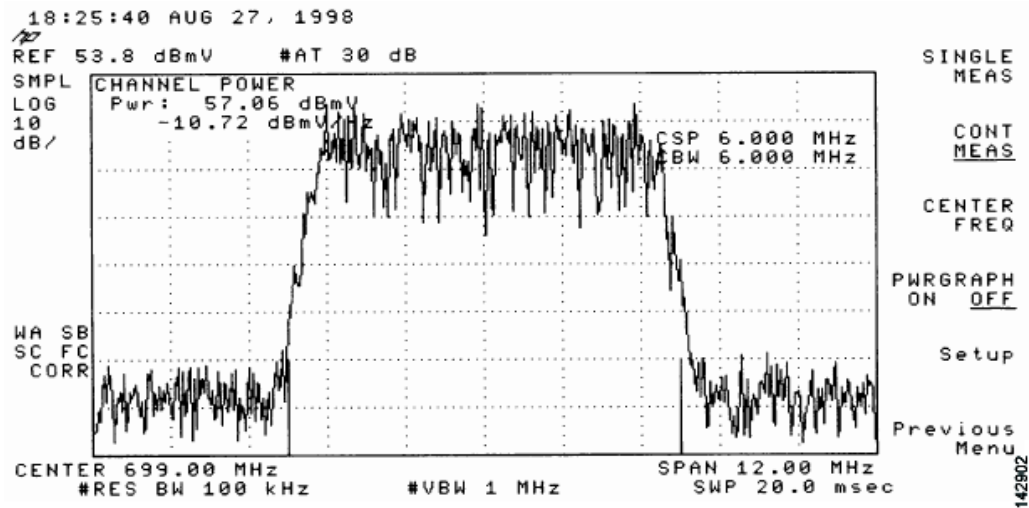
A spectrum analyzer might become overloaded and produce false readings (such as internally generated spurs) when measuring a signal at this amplitude.

**Figure 4-9** Measuring the RF Signal at the Upconverter Output—Upconverter Output Level Too High



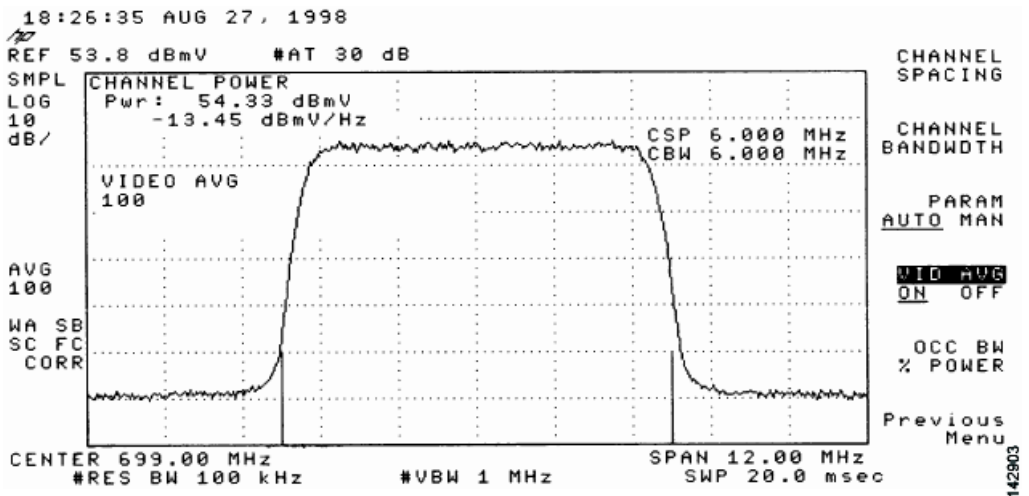
- Step 8** Adjust the power on the upconverter output to ensure that it is between +50 and +61 dBmV. In [Figure 4-10](#), the upconverter output is reading +57.06 dBmV, which is within the correct range.

**Figure 4-10** Measuring the RF Signal at the Upconverter Output—Output Adjusted to Correct Range



**Step 9** Select the video averaging feature on the spectrum analyzer. The signal becomes smoother and frequency response problems might become visible. Your analyzer now displays an RF signal similar to the one shown in Figure 4-11.

**Figure 4-11** Measuring the RF Signal at the Upconverter Output Using Video Averaging



**Note**

The approximate in-channel peak-to-valley flatness may be verified using the spectrum analyzer's video averaging feature. Be aware, however, that amplitude values registered while in the video averaging mode are typically around 2.5 dB below the actual channel power.



- Step 10** Verify that your headend RF measurements meet the recommended DOCSIS parameters listed in the tables in [Appendix B, “RF Specifications.”](#) Record your headend settings and measurements in your headend site log ([Appendix G, “Site Log”](#)). This will assist in troubleshooting the Cisco uBR7225VXR router installation later in the process.

---

This completes the procedure to measure the downstream RF signal using the channel power option. Proceed to the [“Measuring the RF Signal at the Forward Test Point on a Laser Transmitter”](#) section on [page 4-37](#).

## Measuring the Downstream RF Signal Using CATV Mode on a Spectrum Analyzer

The following two sections describe the methods you may use to measure the downstream RF signal using CATV mode (digital channel power option) on a spectrum analyzer:

- [Measuring the Downstream IF Signal at the Cisco uBR7225VXR Router Using CATV Mode, page 4-11](#)
- [Measuring the Downstream RF Signal at the Upconverter Output Using CATV Mode, page 4-14](#)

**Note**

We recommend using as recent a model of spectrum analyzer as possible to perform the two analyses described here. You can use spectrum analyzers, such as the Agilent 8591C (<http://www.tm.agilent.com>) or the Tektronix 2715 (<http://www.tek.com>) to help you perform the tasks outlined in this section.

## Measuring the Downstream IF Signal at the Cisco uBR7225VXR Router Using CATV Mode

**Note**

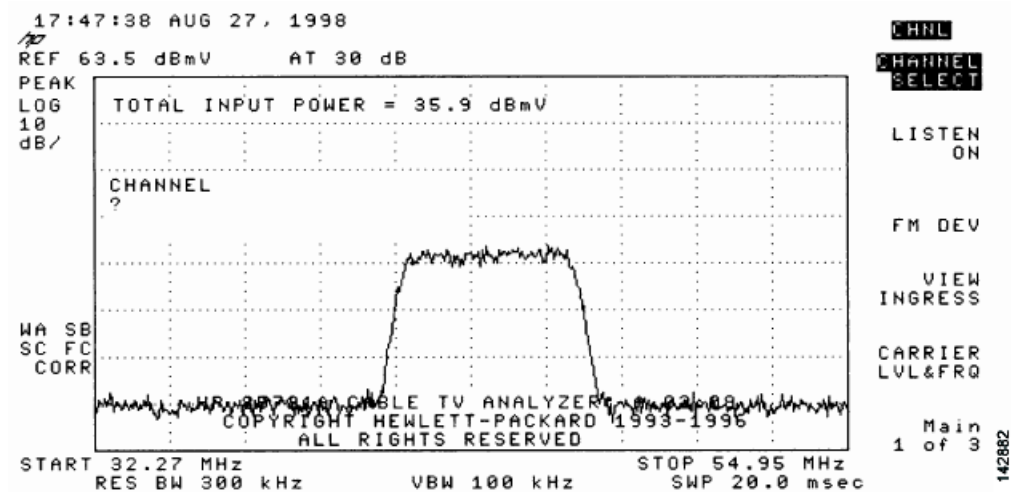
Refer to the user guide that accompanied your spectrum analyzer to determine the exact steps required to use your analyzer to perform these measurements.

- Step 1** Connect a spectrum analyzer to the downstream connector on a Cisco cable interface card installed in a Cisco uBR7225VXR router.
- Step 2** Turn the power switch on the spectrum analyzer to the **on** position.
- Step 3** Set the spectrum analyzer to CATV mode (CATV analyzer option) and select the channel measurement option to view the downstream intermediate frequency (IF) signal. Your analyzer should display a signal similar to the one shown in [Figure 4-12](#).

**Note**

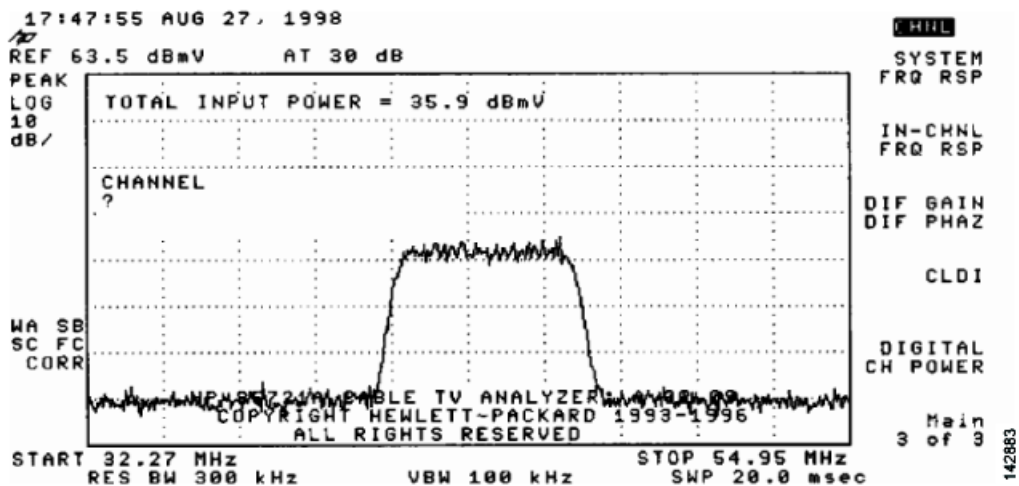
[Figure 4-12](#) shows the first of three screens that will be displayed by an Agilent 8591C when you use the analyzer in this mode. [Figure 4-13](#) is the last of the three screens displayed.

**Figure 4-12** Viewing the Downstream IF Signal on a Spectrum Analyzer in CATV Mode—Initial Screen



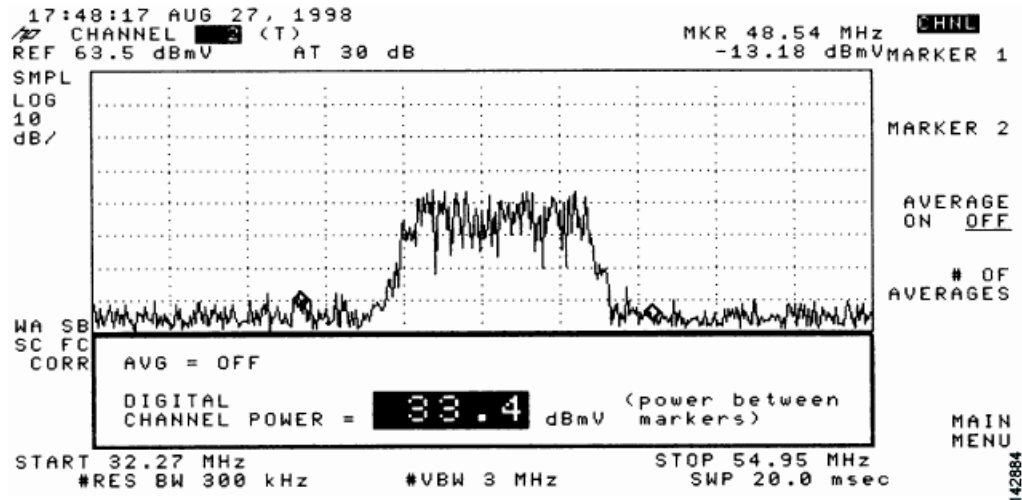
**Step 4** Advance to the last of the three screens in this display. Your analyzer should display a signal similar to the one shown in [Figure 4-13](#).

**Figure 4-13** Viewing the IF Signal on a Spectrum Analyzer in CATV Mode—Preliminary Digital Channel Power Screen



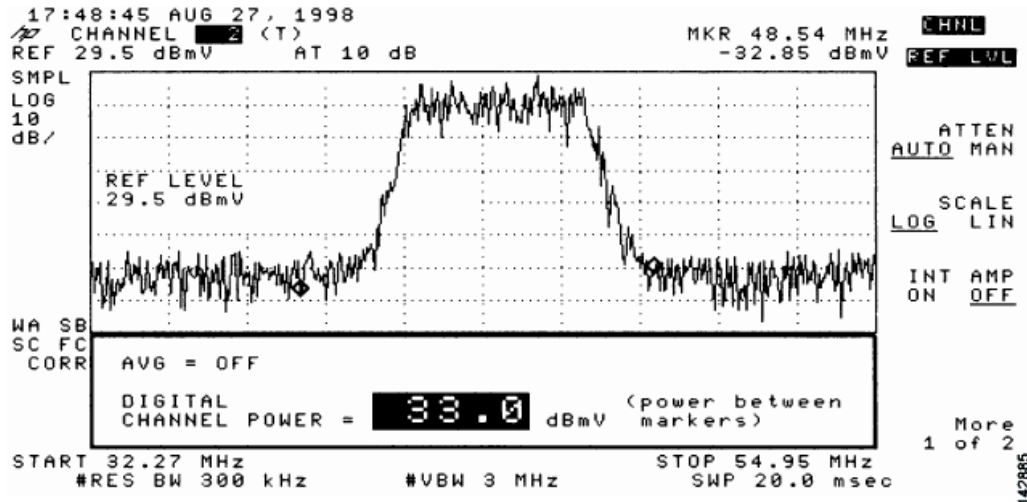
**Step 5** Enter a digital channel to measure and select digital channel power. Your spectrum analyzer will display a signal similar to the one shown in [Figure 4-14](#).

**Figure 4-14** Measuring the IF Signal on a Spectrum Analyzer in CATV Mode—Digital Channel Power Screen



**Step 6** Using the spectrum analyzer's reference level control, adjust the amplitude of the displayed signal until the shape of the signal is clearly distinguishable as a digitally modulated carrier, as shown in Figure 4-15.

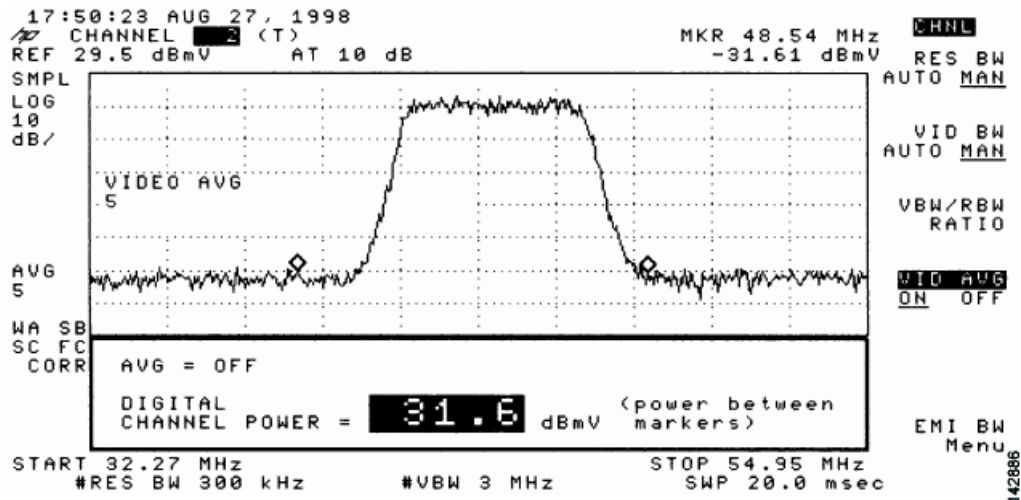
**Figure 4-15** Measuring the IF Signal on a Spectrum Analyzer in CATV Mode—Adjusted Digital Channel Power Screen



**Note** The IF channel power in Figure 4-15 is +33 dBmV, as displayed on the spectrum analyzer.

**Step 7** Select the video averaging feature. Your spectrum analyzer should display a signal similar to the one shown in Figure 4-16.

**Figure 4-16** Measuring the IF Signal on a Spectrum Analyzer in CATV Mode—Digital Channel Power Screen (Using Video Averaging)



**Note**

The approximate in-channel peak-to-valley flatness can be verified using the spectrum analyzer's video averaging feature. Be aware, however, that amplitude values registered while in the video averaging mode are typically around 2.5 dB below the actual channel power.

Proceed to the next section, “[Measuring the Downstream RF Signal at the Upconverter Output Using CATV Mode.](#)”

## Measuring the Downstream RF Signal at the Upconverter Output Using CATV Mode

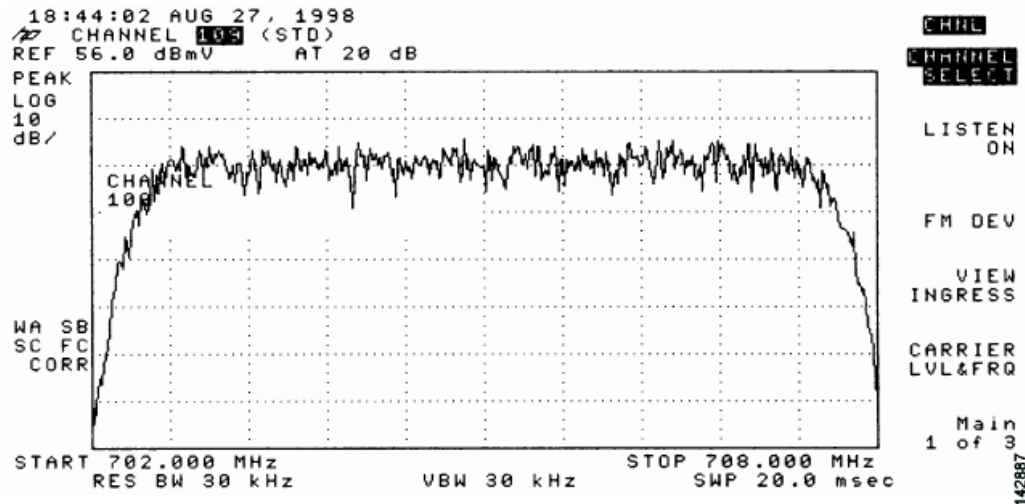
- Step 1** Disconnect the spectrum analyzer from the cable interface card downstream connector.
- Step 2** Connect the downstream output of the cable interface card to the upconverter input connector.
- Step 3** Connect the spectrum analyzer to the RF output of the upconverter.
- Step 4** Set the upconverter output level to the manufacturer's recommended settings. Typical output amplitudes range from +50 to +58 dBmV, although DOCSIS specifies levels as high as +61 dBmV.
- Step 5** Set the spectrum analyzer to view the RF signal at the center frequency you selected for your headend. In this example, the RF center frequency is 705 MHz.
- Step 6** Set the spectrum analyzer to CATV mode (CATV analyzer option) and select the channel measurement option to view the downstream RF signal. Your spectrum analyzer should display a signal similar to the one shown in [Figure 4-12](#).



**Note**

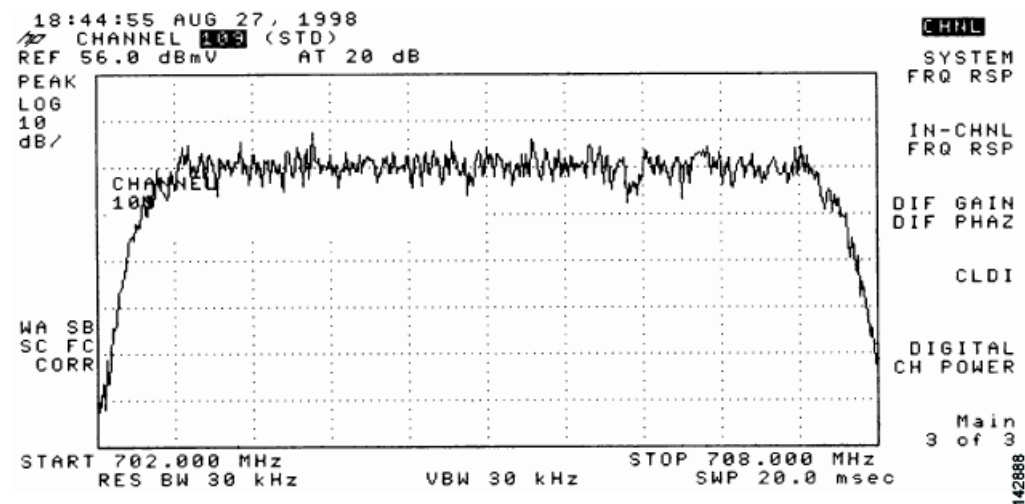
[Figure 4-17](#) shows the first of three screens that will be displayed by an Agilent 8591C when you use the analyzer in this mode. [Figure 4-18](#) is the last of the three screens displayed.

**Figure 4-17** Viewing the Downstream RF Signal on a Spectrum Analyzer in CATV Mode—Initial Screen



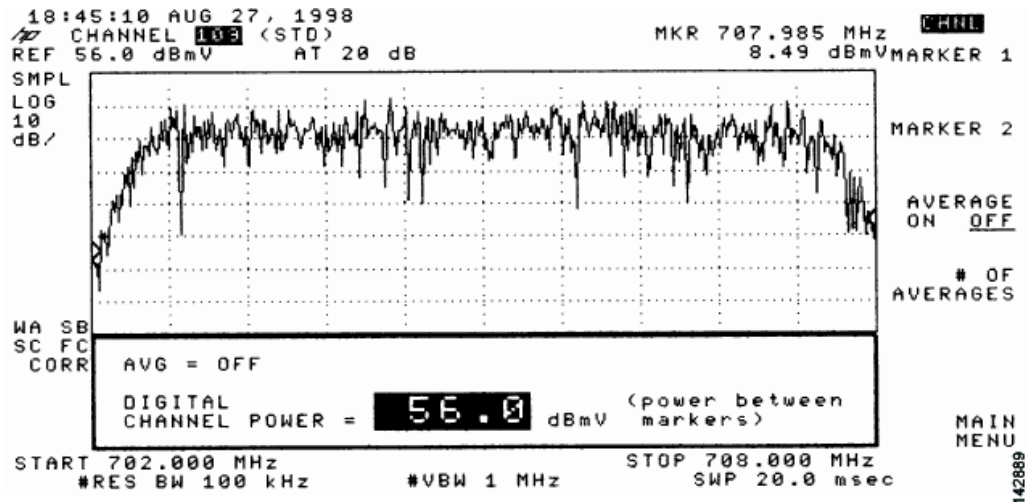
**Step 7** Advance to the last of the three screens in this display. Your analyzer should display a signal similar to the one shown in [Figure 4-18](#).

**Figure 4-18** Viewing the RF Signal on a Spectrum Analyzer in CATV Mode—Preliminary Digital Channel Power Screen



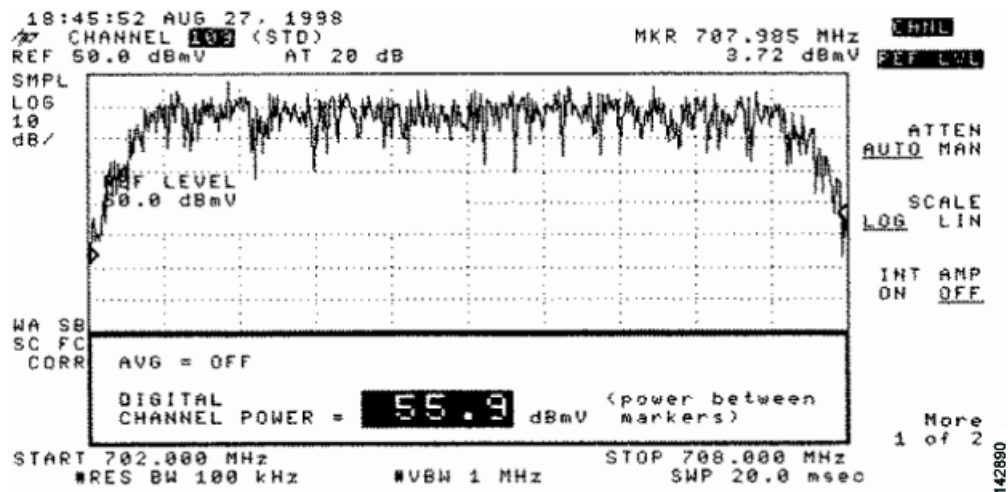
**Step 8** Enter a digital channel to measure and select digital channel power. Your spectrum analyzer will display a signal similar to the one shown in [Figure 4-19](#).

**Figure 4-19** Measuring the RF Signal at the Upconverter Output in CATV Mode—Digital Channel Power Screen



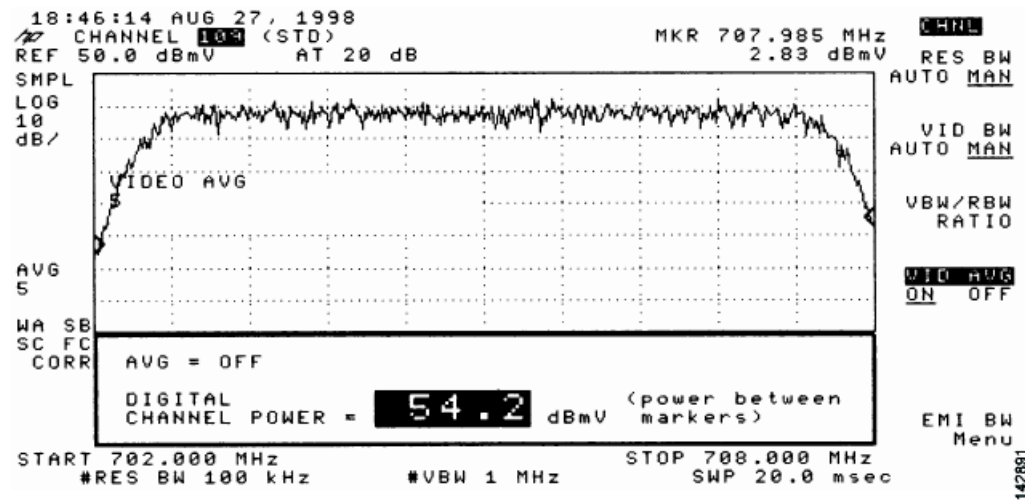
**Step 9** Using the spectrum analyzer's reference level control, adjust the amplitude of the displayed signal until the signal peak is within the top graticule of the analyzer's display grid, as shown in [Figure 4-20](#).

**Figure 4-20** Measuring the RF Signal at the Upconverter Output in CATV Mode—Adjusted Digital Channel Power Screen



**Step 10** Select the video averaging feature. Your spectrum analyzer should display a signal similar to the one shown in [Figure 4-21](#).

**Figure 4-21** Measuring the RF Signal at the Upconverter Output in CATV Mode—Digital Channel Power Screen Using Video Averaging



**Note**

The approximate in-channel peak-to-valley flatness can be verified using the spectrum analyzer's video averaging feature. Be aware, however, that amplitude values registered while in the video averaging mode are typically around 2.5 dB below the actual channel power.

- Step 11** Verify that your headend RF measurements meet the recommended DOCSIS parameters listed in the tables in [Appendix B, "RF Specifications."](#)
- Step 12** Record your headend settings and measurements in [Appendix G, "Site Log."](#) as you verify them. This will assist in troubleshooting the Cisco uBR7225VXR router installation later in the process.
- Step 13** After you have analyzed and adjusted the RF signal according to the steps outlined on the preceding pages, proceed to the ["Connecting and Configuring the Upstream"](#) section on page 4-18.

# Connecting and Configuring the Upstream

The following sections describe how to connect and configure the upstream for digital data.

## Connecting the Upstream to the Optical Receiver

To connect the upstream to the optical receiver, use a 2-way splitter as a combiner to leave the DOCSIS cable modem connected at the headend, and connect the upstream headend cable to the optical receiver. (See [Figure 4-22](#).)

The default upstream input level to the Cisco uBR7225VXR cable interface line card is 0 dBmV. You may adjust the upstream input level to other values using the Cisco IOS software running on your router. The Cisco uBR7225VXR router uses automatic power control when transmitting to remote cable modems. Accurately setting the power level helps to ensure reliable cable modem operation.

[Table 4-1](#) provides upstream input power ranges for the various cable interface line cards available for the Cisco uBR7225VXR router, depending on the channel bandwidth you are using.

**Table 4-1 Upstream Input Power Ranges According to Cable Interface Line Card Type**

Channel Bandwidth	Cisco MC11 FPGA	Cisco MC16E and MC16S	DOCSIS Specification
200 KHz	N/A	-10 to +25 dBmV	-16 to +14 dBmV
400 KHz	N/A	-10 to +25 dBmV	-13 to +17 dBmV
800 KHz	N/A	-10 to +25 dBmV	-10 to +20 dBmV
1.6 MHz	-10 to +10 dBmV	-10 to +25 dBmV	-7 to +23 dBmV
3.2 MHz	N/A	-10 to +25 dBmV	-4 to +26 dBmV

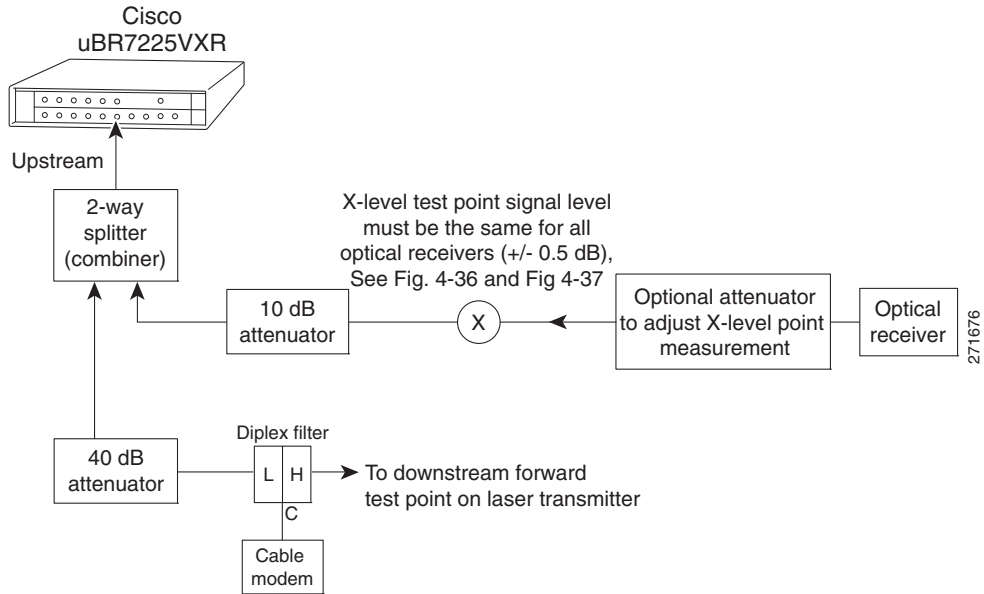


### Note

If you have a Cisco uBRMC16x cable interface line card (six upstream ports and one downstream port) installed in your Cisco uBR7225VXR router, the 2-way splitter described above would be replaced by six 2-way splitters (one splitter per upstream port). This would enable you to connect to all of the available upstream ports on the Cisco uBRMC16x.



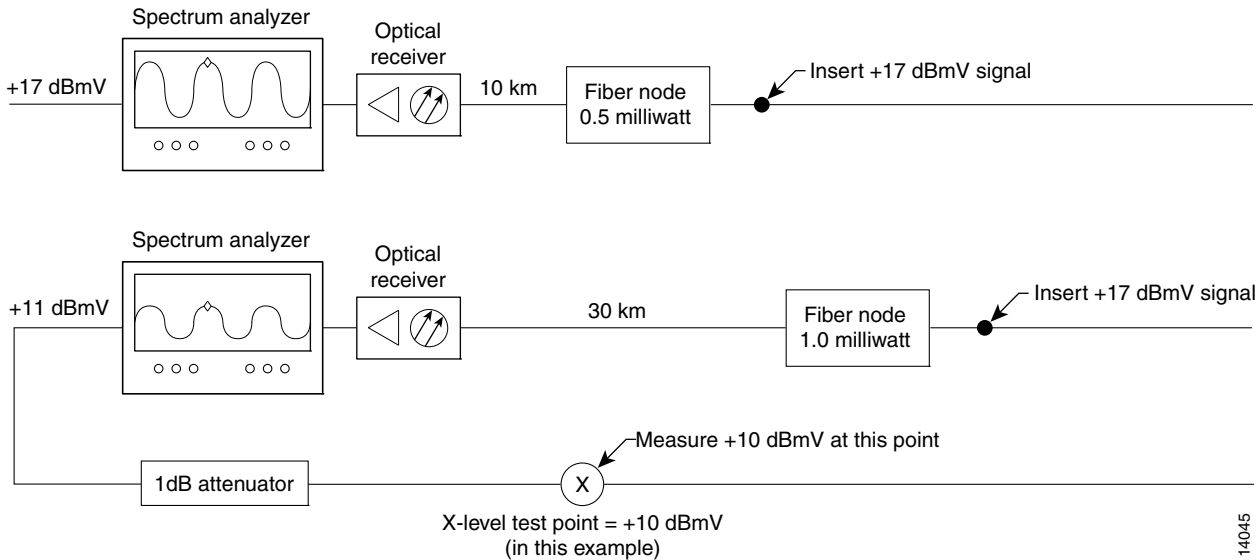
**Figure 4-22** Connecting and Configuring the Upstream



## Testing the Upstream Configuration

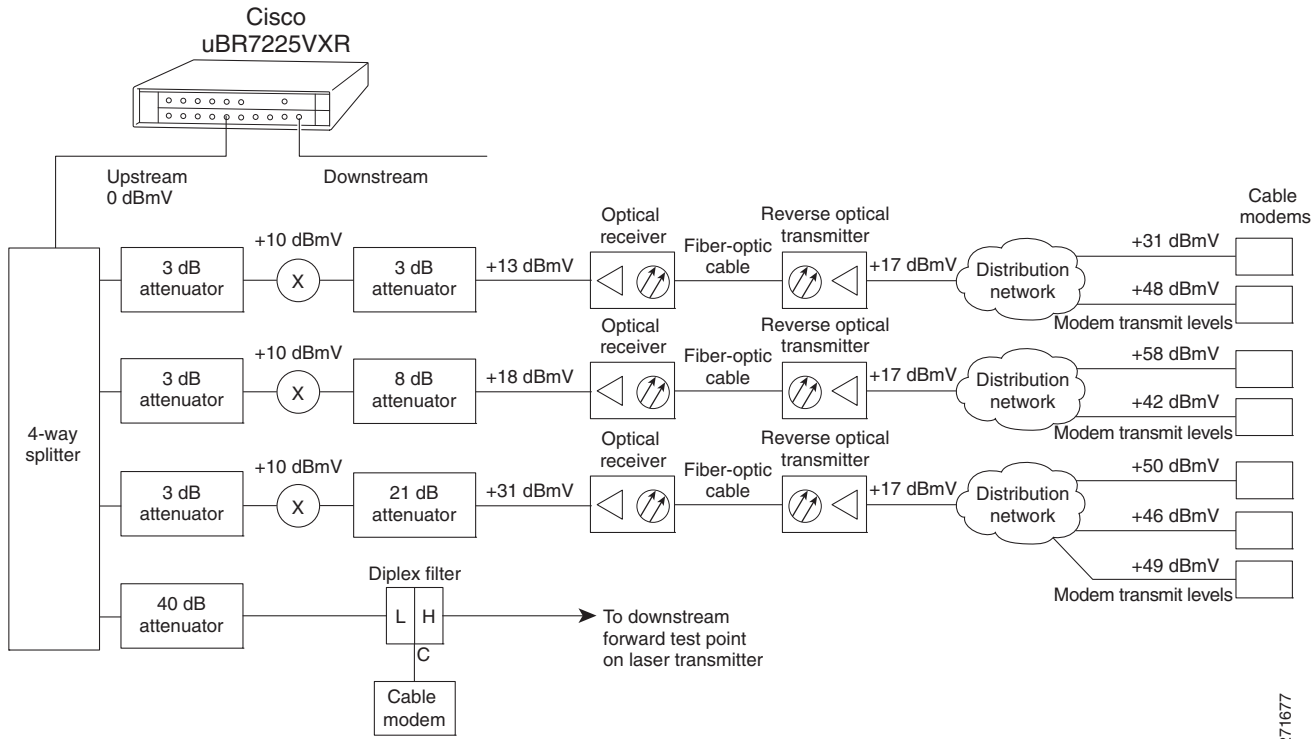
To test the upstream configuration, insert a test signal of known amplitude (+17 dBmV is shown in this example) into the fiber node and measure the amplitude output level at the output of the headend's optical receiver. This measurement depends on return laser performance and optical distance. This procedure is known as establishing the "X-level" test point. (See [Figure 4-23](#).)

**Figure 4-23** The "X-level" Test Point



This “X-level” test point measurement will be different for every fiber node in the HFC network until you adjust the attenuation on the upstream. You must adjust the attenuation so that this measurement is the same on every fiber node. If you change a receiver or a transmitter at the fiber node, or if you unplug a connector and plug it back in, you must recheck this amplitude measurement. Figure 4-24 shows how three distribution network “X-level” test points connected to the same upstream port are all calibrated to +10 dBmV using different attenuators.

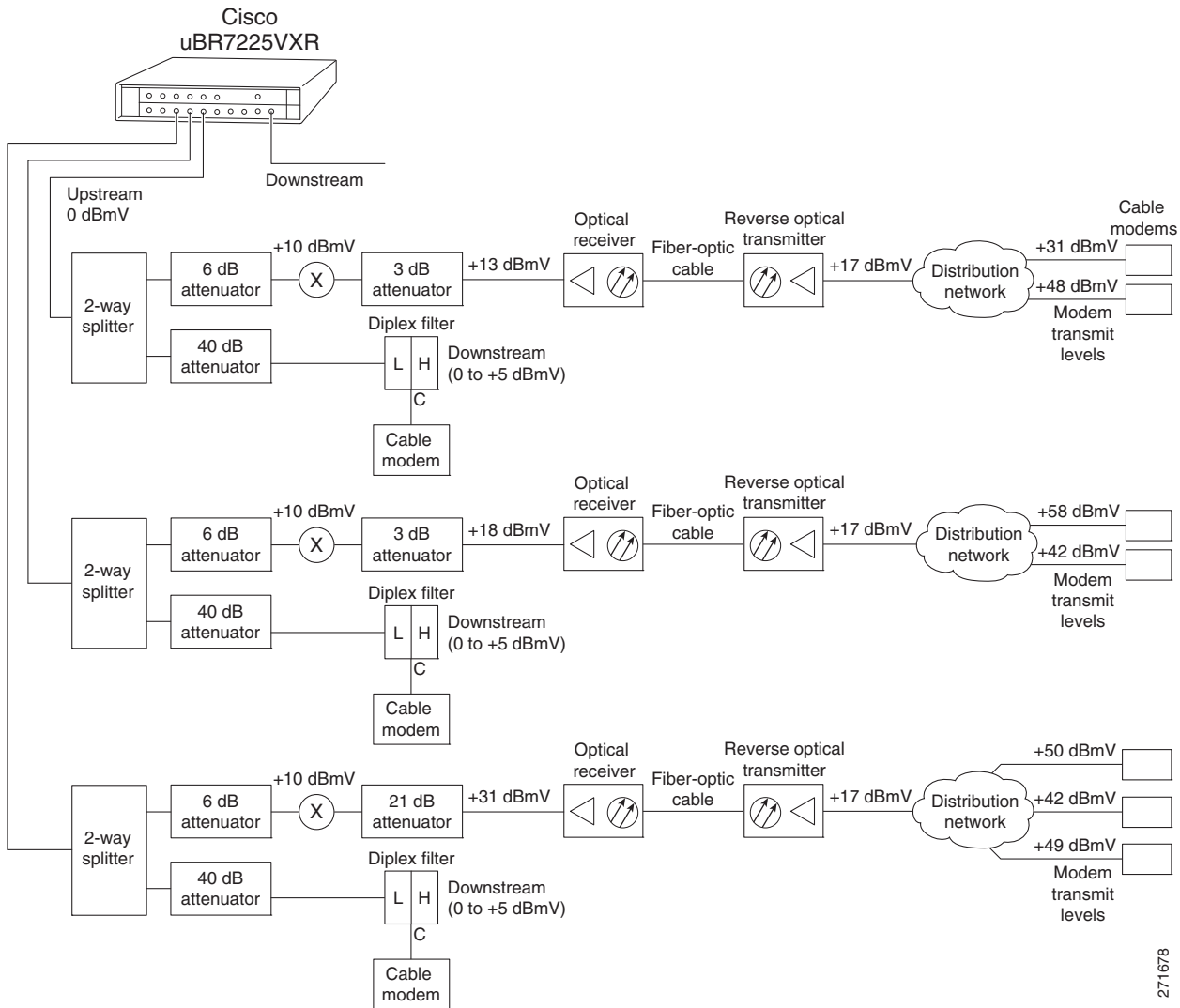
Figure 4-24 Calibrating Multiple “X-level” Test Points Connected to One Upstream Port



271677

Figure 4-25 shows how three distribution network “X-level” test points connected to the three different upstream ports are all calibrated to +10 dBmV using different attenuators.

Figure 4-25 Calibrating Multiple “X-level” Test Points Connected to Multiple Upstream Ports



## Measuring the Upstream RF Signal

You can use a spectrum analyzer to measure the upstream signal from one or more remote cable modems in a two-way data cable network. Performing this procedure can help alert you to potential problems in your cable network's upstream configuration before a problem occurs. This helps to avoid trying to solve a problem after a remote cable modem has experienced a failure in service. This procedure is referred to as the "zero-span" method.

### Measuring the Upstream RF Signal Using a Spectrum Analyzer

This procedure is designed to help you accurately measure an upstream RF signal where no adjacent channels are in use. To measure an upstream RF signal with active adjacent channels, refer to the ["Using the Zero-Span Method with Adjacent Upstream Channels"](#) section on page 4-28.


**Note**

Refer to the user guide that accompanied your spectrum analyzer to determine the exact steps required to use your analyzer to perform these measurements.

- 
- Step 1** Connect the spectrum analyzer to the upstream signal from your cable network.
  - Step 2** Turn the power switch on the spectrum analyzer to the **on** position.
  - Step 3** Set the spectrum analyzer to view the upstream RF signal with a center frequency matching the actual upstream center frequency defined in your Cisco uBR7225VXR router configuration file.
  - Step 4** Set the spectrum analyzer's span to 0 MHz.

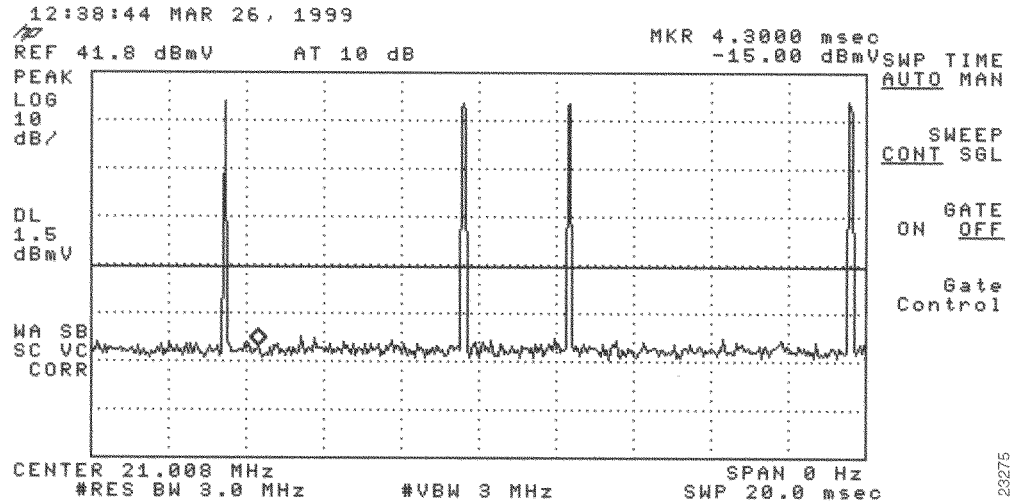

**Note**

You can view the configuration file for your Cisco uBR7225VXR router by using the **show controller cable slot/upstream/port** command, available in Cisco IOS Release 11.3(6)NA or later releases and Cisco IOS Release 12.0(5)T1 or later releases. For example, if you wanted to view the center frequency of port 0 on a cable interface card in slot 3, you would enter the **show controller cable 3/0** command.

If you have assigned spectrum groups in your configuration file, use the **show cable hop** command to display the current upstream center frequency for each cable interface.

- Step 5** Set both the resolution bandwidth and the video bandwidth on the spectrum analyzer to 3 MHz and the sweep rate to 20 microseconds. Provided there is a large amount of activity on your upstream channel, the spectrum analyzer should display a signal similar to the one shown in [Figure 4-26](#).

**Figure 4-26** Measuring the Upstream RF Signal—Setting the Resolution and Video Channel Bandwidth



**Tip**

The horizontal line passing through the center of the spectrum analyzer display in Figure 4-26 is the trigger line.

**Step 6**

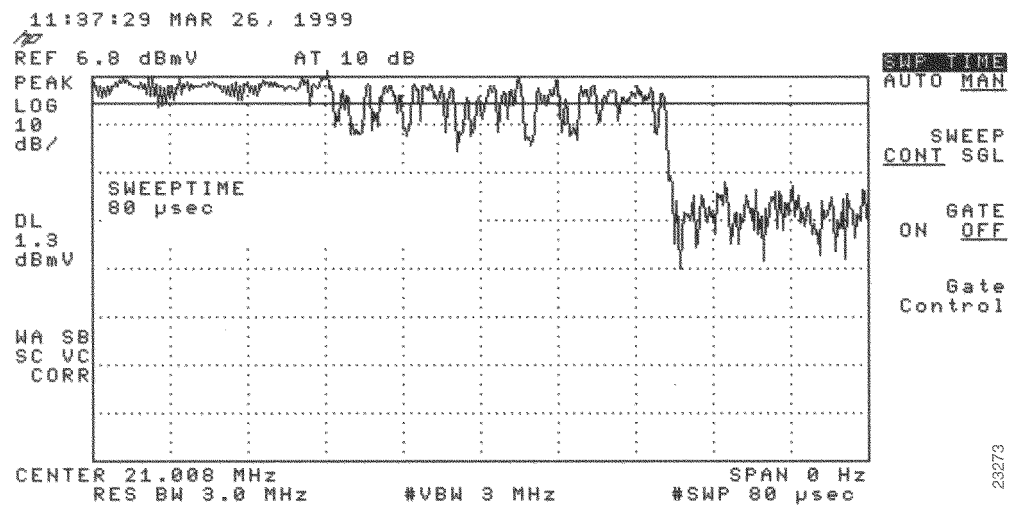
Set the sweep value to 80 microseconds. Your spectrum analyzer should display a signal similar to the one shown in Figure 4-27.



**Note**

Be sure that your particular spectrum analyzer is capable of supporting sweep times as short as 80 microseconds.

**Figure 4-27** Measuring the Upstream RF Signal—Setting the Sweep Time Period



**Step 7**

Position the trigger line on the spectrum analyzer so that it is roughly in the middle (approximately halfway between the highest and lowest portions) of the upstream RF signal.



**Note** Refer to the documentation that accompanied your particular spectrum analyzer for detailed instructions on activating and positioning the trigger line.

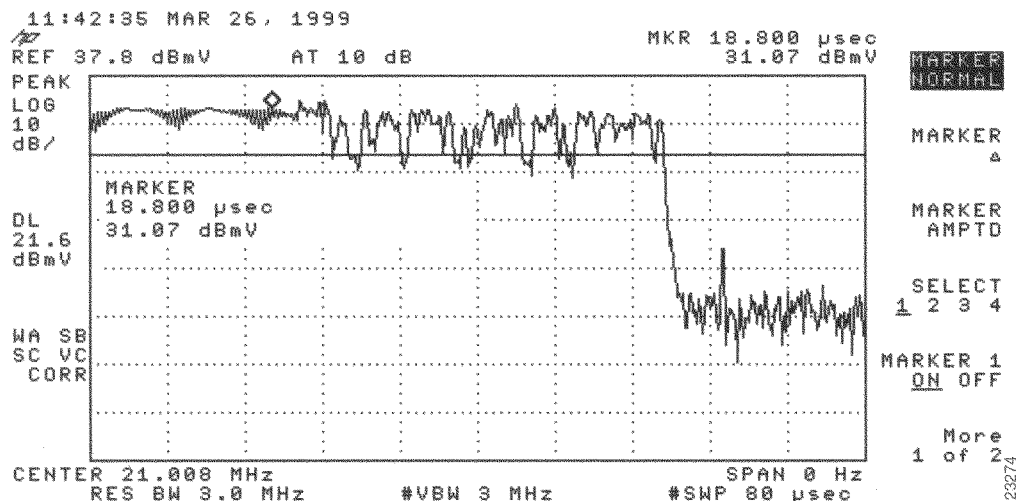
A known workaround exists for the Agilent 8591C spectrum analyzer. After activating and positioning the trigger line in video mode, you *must* press the “video” button on the spectrum analyzer once more to enable proper functionality.

**Step 8** Adjust the amplitude on your spectrum analyzer so that the uppermost portion of the upstream RF signal is in the top graticule of the analyzer’s display grid and adjust the trigger line accordingly. Your spectrum analyzer will then display an upstream RF signal similar to the one shown in [Figure 4-28](#).



**Note** We do not recommend using the spectrum analyzer’s “max-hold” feature while analyzing upstream signals in the frequency domain. “Max-hold” readings in the frequency domain can be inaccurate because the analyzer focuses on the peak power of the strongest ranging modem rather than the power levels of cable modems that are operating in a more ideal range.

**Figure 4-28** *Measuring the Upstream RF Signal—Accurately Measured Amplitude on Spectrum Analyzer*



**Step 9** Position a marker about 7/8 of the way into the preamble of the signal, as illustrated in [Figure 4-28](#). (The preamble is the regular pattern displayed at the front of the signal and the length of the preamble is a function of the channel width/data rate, modulation format, and DOCSIS burst-profile configurations.) The peak amplitude of the marker, which registers +31.07 dBmV in this case, will be within 1 dB of the true burst power.



**Note** To verify this reading, you can also measure the power rating with an Agilent 89441A vector signal analyzer (<http://www.tm.agilent.com>).

If the preamble of your upstream signal is displayed with a significantly lower amplitude than the rest of the RF signal, refer to the “[Using the Zero-Span Method with Adjacent Upstream Channels](#)” section on [page 4-28](#) for instructions on how to overcome this phenomenon.

- Step 10** Verify that your headend RF measurements meet the recommended DOCSIS parameters listed in the tables in [Appendix B, “RF Specifications.”](#)
- Step 11** Record your headend settings in [Appendix G, “Site Log.”](#) This will assist in troubleshooting the Cisco uBR7225VXR universal broadband router installation later in the process.

**Note**

Be sure not to narrow the focus of your analysis any further than approximately 3-MHz channel width. Doing so can yield incorrect readings. For example, if you were to view an upstream RF signal with a resolution bandwidth of only 300 kHz and a video channel bandwidth of only 100 kHz, your measurements would register lower than the actual transmission levels.

## Analyzing the Upstream RF Signal

When you have set up your spectrum analyzer to accurately read the upstream RF signal, you can verify that a remote cable modem is operating as it should by pinging the modem via a console terminal.

- Step 1** Log in to your Cisco uBR7225VXR universal broadband router with a console terminal.
- Step 2** Adjust the sweep time on your spectrum analyzer to 20 microseconds.
- Step 3** Ping the remote cable interface card using first a 64-byte, then a 1500-byte ping packet request, and take note of the upstream RF signal in each case. Several hundred or thousand ping packets might be required for a usable pattern to emerge.

[Figure 4-29](#) and [Figure 4-30](#) provide two examples of an ideal upstream RF signal based on a simple 64- or 1500-byte ping of a single remote cable interface. The more slender of the data spikes in the RF signal (the first and third spikes in [Figure 4-29](#)) are bandwidth request packet transmissions, while the larger spikes are the actual 64- or 1500-byte ping packet returns.

**Figure 4-29 Analyzing the Upstream RF Signal—64-Byte Data Packets**

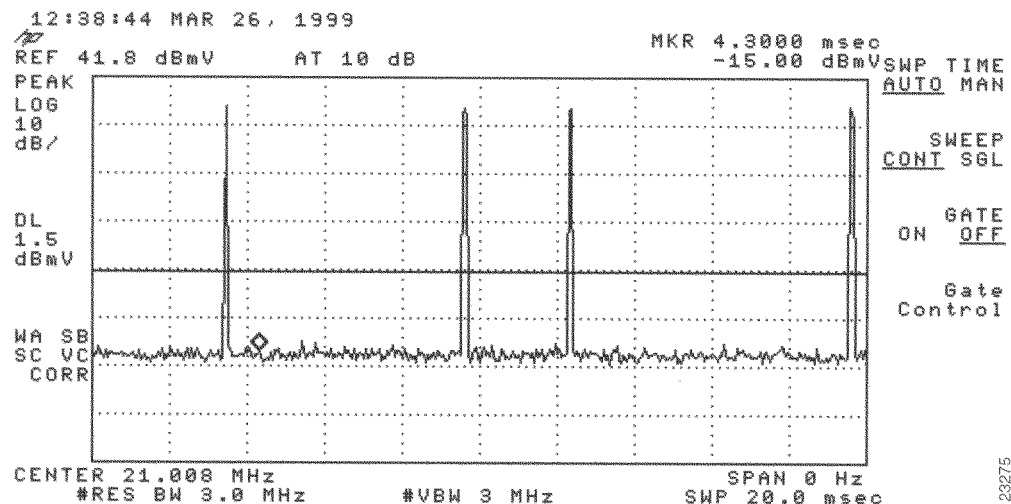
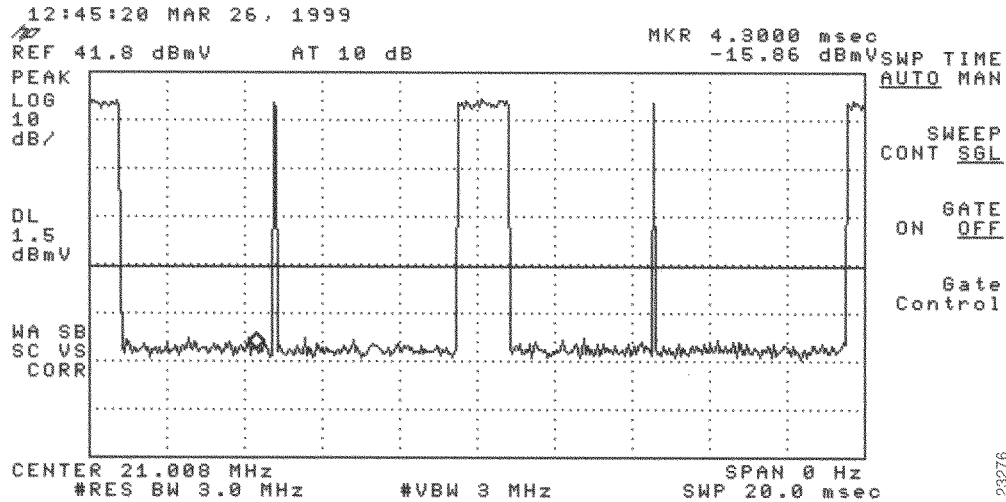


Figure 4-30 Analyzing the Upstream RF Signal—1500-Byte Data Packets



**Note** Both of the previous examples feature 16-QAM transmission with a channel width of 3.2 MHz, yielding a 10-Mbit/sec data rate. In addition, these examples have an optimal upstream carrier-to-noise ratio of approximately 50 dB.

Now it is time to view your upstream RF signal with multiple remote cable modems. Figure 4-31 and Figure 4-32 both display upstream RF signals encompassing more than one remote cable modem. In each case, there are two bandwidth requests followed by their respective ping packet returns, both at slightly different amplitudes. This situation is most commonly caused by a difference in the receive power from the two cable modems in question. In the example, the remote cable modem with the lesser amplitude is “cable modem A” and the other is “cable modem B.”

In the following example, cable modem A and cable modem B have been artificially configured to yield a larger than normal difference in amplitude between their respective upstream RF transmissions. Under normal conditions, the maximum difference in amplitude between any cable modems will be about 1.5 dB. Differences greater than 1.5 dB indicate a possible cable plant or remote cable modem problem.



**Note** To further illustrate this point, you can log in to your Cisco uBR7225VXR router using a console terminal and enter the **show cable modem** command to obtain a report of the receive power ratings for each modem. In the example, the receive power ratings for remote cable modems A and B are -2 dBmV and 0 dBmV, respectively.

The two bandwidth requests and ping packet returns on the upstream RF signal for cable modems A and B are slightly different in Figure 4-31 and Figure 4-32. Differences in the distance between bandwidth requests are primarily caused by the contention-based nature of multiple remote cable modems on the same line. Differences in the distance between ping packet returns are primarily caused by factors such as packet size and system loading.



Figure 4-31 Analyzing the Upstream RF Signal—Multiple Active Remote Cable Modems (A)

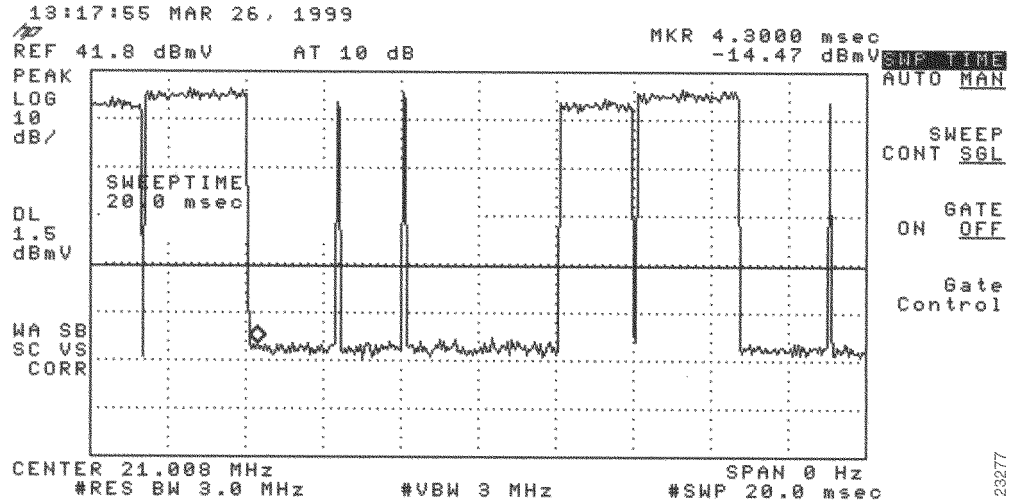
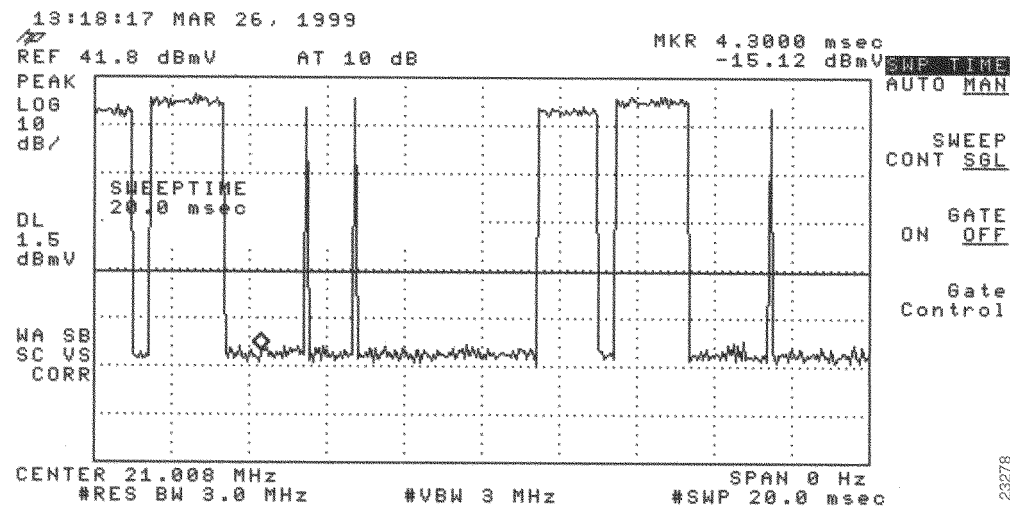


Figure 4-32 Analyzing the Upstream RF Signal—Multiple Active Remote Cable Modems (B)

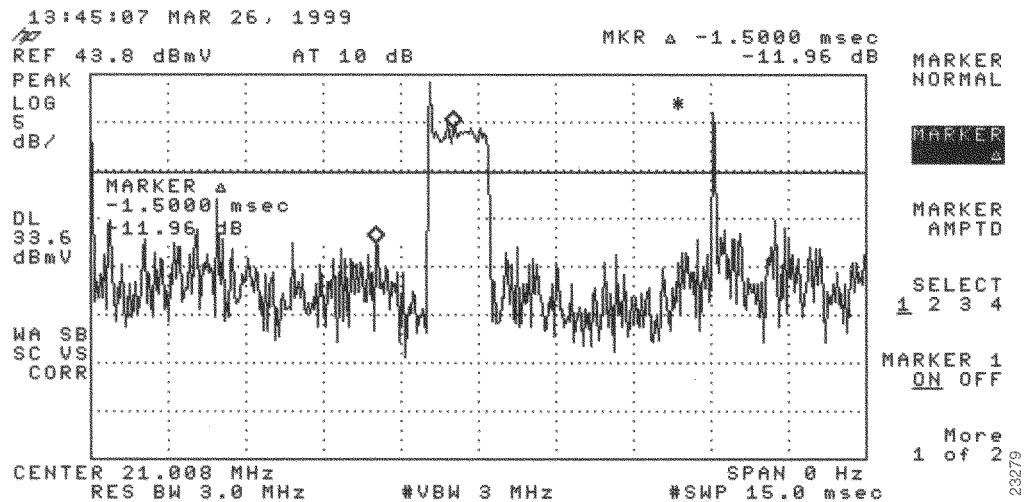
**Note**

When viewing the upstream RF signal on your spectrum analyzer, two ping packet returns (for example, from remote cable modems A and B) can be so close together that they appear to be one rather large packet with a slight jump or decline in amplitude halfway through the measurement. This is an indication that the upstream is 100 percent occupied during this time.

Figure 4-33 shows an upstream RF signal from a remote cable modem in a “real-life” scenario including outside plant noise. Notice the relatively tall spike at the very left edge of the ping packet return. This spike is mainly additive noise associated with an upstream RF signal mired by excessive amounts of severe outside plant noise (as in this example). In addition, notice that the carrier-to-impulse noise ratio measurement between the two diamond-shaped markers is only about 12 dB. (A few other noise peaks are even worse.)

The importance of this example is to bring to your attention the need for minimal outside plant noise. Time-varying, fast noise can cause bit errors in packet transmissions, rendering your communication link unreliable, if not unusable.

**Figure 4-33 Analyzing the Upstream RF Signal—Outside Plant Noise Included**



**Note**

This illustration depicts an upstream RF signal whose carrier-to-impulse noise ratio does not meet DOCSIS 1.0 specifications. The data packet in Figure 4-33 was “dropped” due to severe noise interference with a more narrow resolution bandwidth.

## Using the Zero-Span Method with Adjacent Upstream Channels

When measuring upstream signals using the zero-span method, a very wide resolution and video bandwidth give very accurate readings, but render your readings susceptible to energy in adjacent channels. As the number of upstream services increases, so does the likelihood of interference from adjacent channels. This section describes using the zero-span power measurement method, with a more narrow resolution bandwidth.

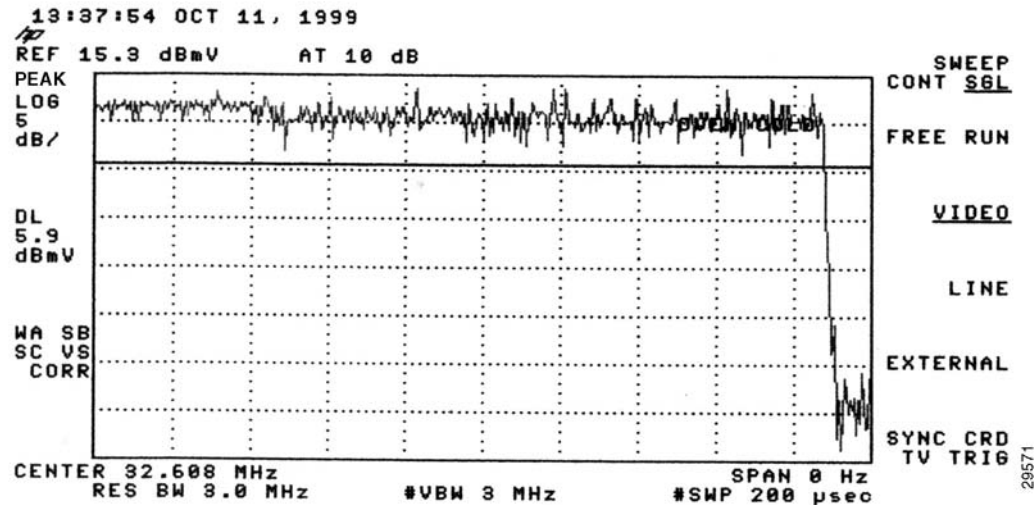
Simply narrowing the resolution bandwidth will not yield accurate readings. See Table 4-2.

**Table 4-2 Sample Channel Width and Symbol Rate Combinations with Their Respective Minimum Resolution Bandwidth Measurements**

Center Frequency	Channel Width	Symbol Rate	1/2 Symbol Rate	Center Frequency +/-1/2 Symbol Rate	Minimum Resolution Bandwidth
20.000	200 kHz	160	80	20.080 and 19.020 MHz	10 kHz
30.000	400 kHz	320	160	30.160 and 29.840 MHz	30 kHz
40.000	800 kHz	640	320	40.320 and 39.680 MHz	100 kHz
25.000	1.6 MHz	1280	640	25.640 and 24.360 MHz	100 kHz
28.000	3.2 MHz	2560	1280	29.280 and 27.720 MHz	300 kHz

- Step 1** Display a signal complete with preamble and upstream data transmission information similar to the resulting signal from [Step 3](#) through [Step 10](#) under the “[Measuring the Upstream RF Signal Using a Spectrum Analyzer](#)” section on page 4-22. Your spectrum analyzer should display a signal similar to the one in [Figure 4-34](#).

**Figure 4-34** Preamble Amplitude Before Resolution and Video Bandwidth Reduction



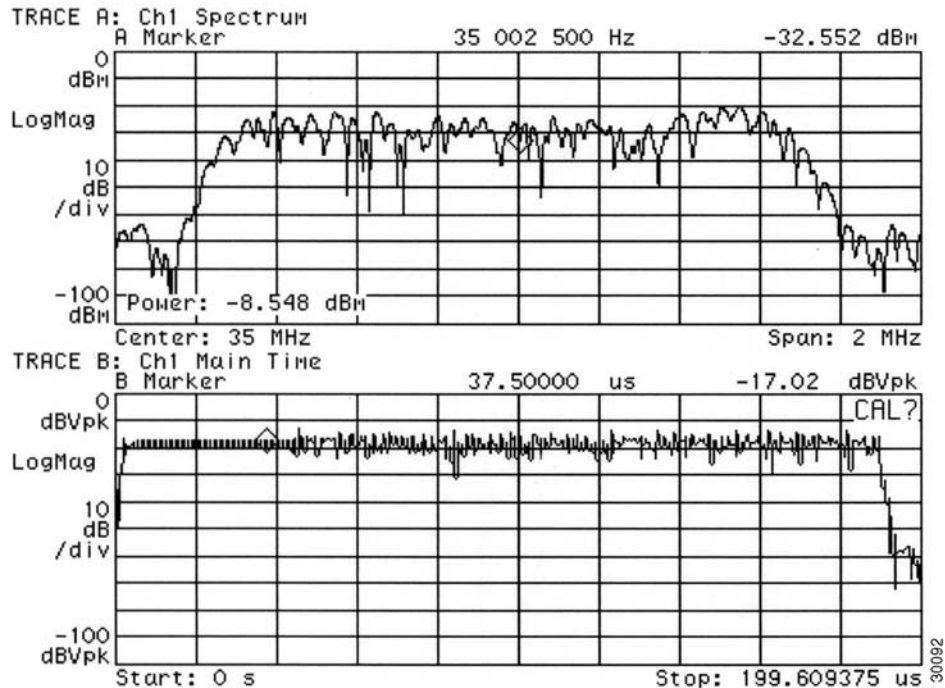
**Note**

[Figure 4-34](#) is a display from a standard spectrum analyzer. The following figures, [Figure 4-35](#) through [Figure 4-38](#), are taken from a vector signal analyzer. If you do not have access to a vector signal analyzer, or want to skip the following section describing its use when viewing your upstream signal, proceed to [Step 3](#).

- Step 2** (Optional) View your upstream signal using a vector signal analyzer such as the Agilent 89441A.
- The advantage of displaying these signals with the vector signal analyzer is that you can view them over the time domain for a specified time interval. In addition, the vector signal analyzer enables you to measure the digital channel power of a very short duration data transmission, like the preamble of a digital signal.
- Set up your vector signal analyzer to view both the “frequency” domain and “time” domain of your upstream signal. Your vector signal analyzer should display a pair of signals similar to those in [Figure 4-35](#).

Figure 4-35 Vector Signal Analyzer Plot of Upstream Data Burst

Date: 10-11-99 Time: 06:13 PM



The upper graph in [Figure 4-35](#) represents the frequency domain and the lower graph represents the time domain.

In the time domain, the channel power of the preamble of a digital upstream signal is not spread across the entire channel. However, the channel power of the remainder of the digital transmission *is* spread across the entire channel. Even though it may not seem so, the total channel power across both the preamble and the subsequent data segment remains constant.

- b. Narrow the view on your vector signal analyzer to display only the preamble of the digital data signal in both the frequency domain and time domain.

The upper display in [Figure 4-36](#) is a plot of only the preamble portion of the digital signal in [Figure 4-35](#). Notice how the amplitude of the signal experiences many “peaks” and “valleys.” When you are measuring the preamble power using the zero-span method, be sure that you measure the actual signal energy (a peak), rather than accidentally measuring the power level of a valley in the preamble.

**Figure 4-36** Vector Signal Analyzer Plot of Upstream Data Burst (Preamble Only)

Date: 10-11-99 Time: 06:12 PM

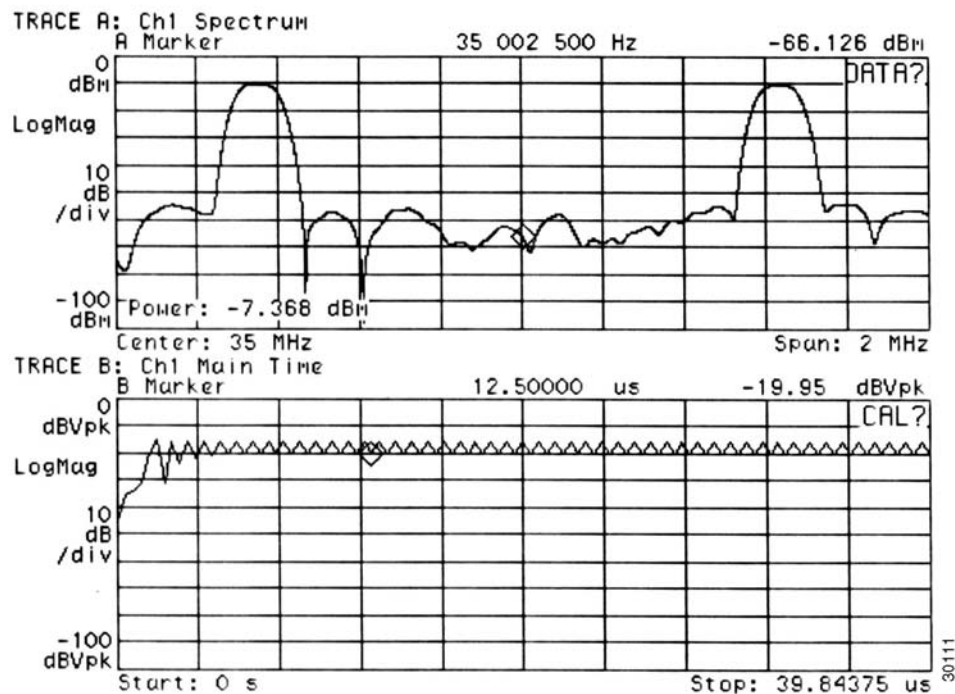


Figure 4-35 and Figure 4-36 illustrate the benefit of properly adjusting the center frequency of your spectrum analyzer to enable the power measurement of the preamble to match the power measurement of the rest of the digital transmission.

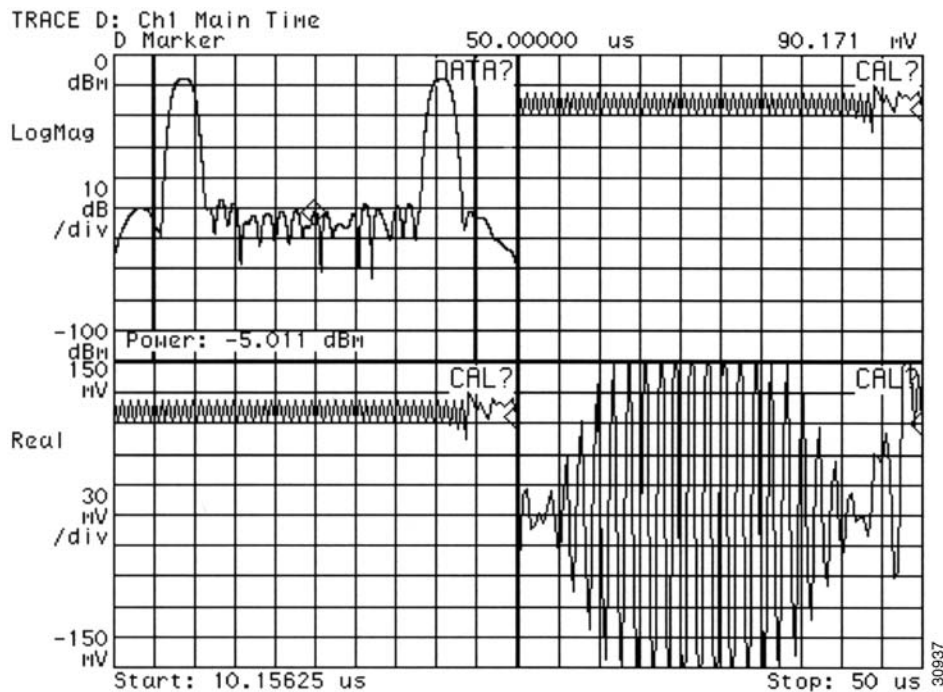
Figure 4-35 and Figure 4-36 show how adjusting the spectrum analyzer in the time domain reveals this frequency domain phenomenon. The spectrum analyzer is unable to capture the data as shown in the vector signal analyzer plots.

The power level in the upstream channel fluctuates by approximately 1 dB between Figure 4-35 and Figure 4-36. This difference is within both the measurement tolerance of the vector signal analyzer and the accuracy requirement for any DOCSIS-based cable modem.

- c. Switch your vector signal analyzer over to Digital Demodulation Mode. Your vector signal analyzer displays a set of screens similar to those in Figure 4-37.

Using this mode to view your upstream signal allows you to view the same time and frequency domain information found in Figure 4-36, as well as the upstream signal's phase characteristics, shown in the bottom-right portion of the vector signal analyzer display screen.

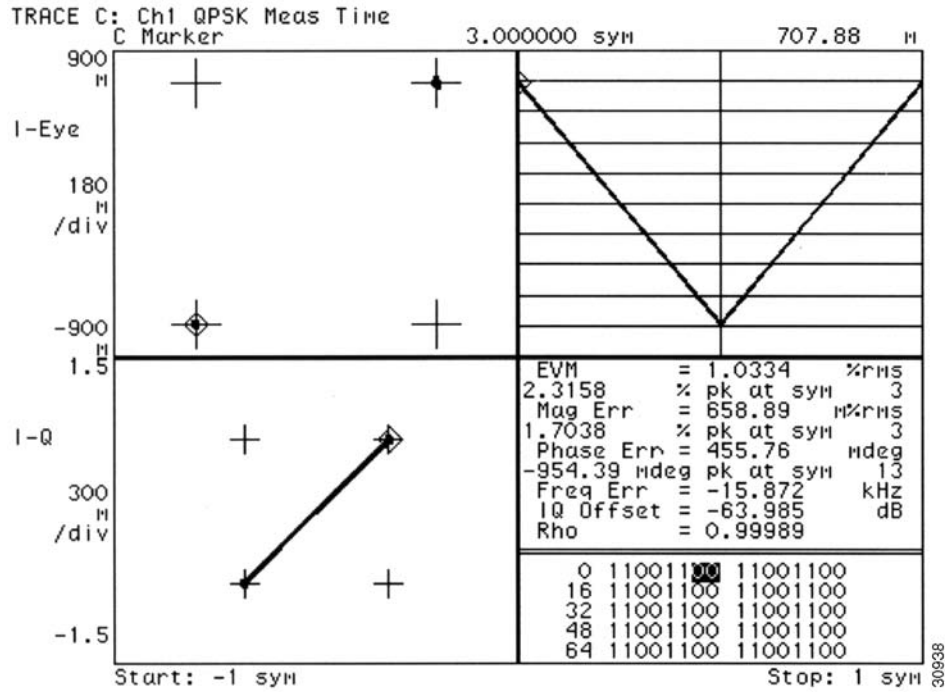
**Figure 4-37** Vector Signal Analyzer Plot of Upstream Data Burst (Preamble Only)—QPSK Demodulation Mode



- d. Switch your vector signal analyzer over to quaternary phase shift keying (QPSK) demodulation mode. Your vector signal analyzer will display a set of screens similar to those in [Figure 4-38](#).

[Figure 4-38](#) displays the QPSK demodulation information for the same upstream signal as in [Figure 4-37](#). However, there are some notable differences in the information presented. For example, notice that the constellation and transition graphs (top and bottom left) both indicate only two of the four QPSK data points handling any bits. Because this graph is covering only the preamble of the data transmission, you get to see only a portion of the whole signal performance. (If you were to view the entire signal transmission in this mode, all four QPSK data points would display bits.)

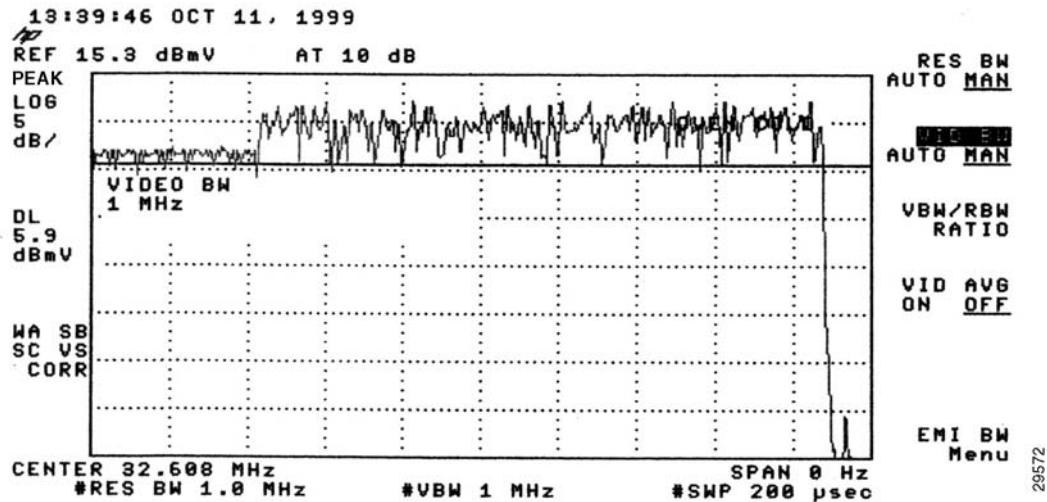
**Figure 4-38** Vector Signal Analyzer Plot of Upstream Data Burst (Preamble Only)—Digital Demodulation Mode



**Note** Before moving on to [Step 3](#), be sure to hook your spectrum analyzer back up to the upstream signal source.

**Step 3** On your spectrum analyzer, narrow both the resolution and video bandwidth to 1 MHz. You will notice that the preamble of the signal has dropped in amplitude, yielding a spectrum analyzer display similar to the one in [Figure 4-39](#).

Figure 4-39 Preamble Amplitude Before Center Frequency Adjustment

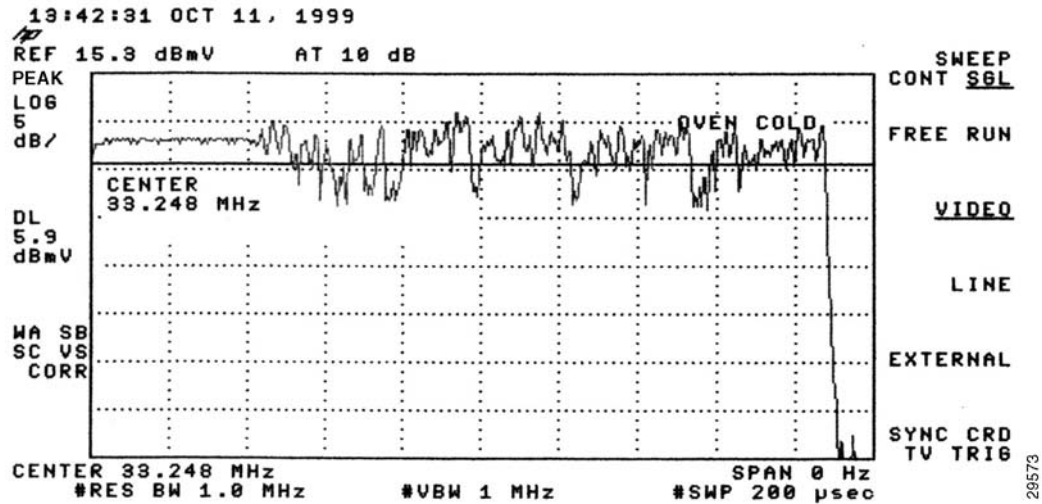


**Note** The slight amplitude variations shown in these figures are normal signal level variations between bursts in the upstream channel. Expect modems to vary upstream transmit power by nearly 1 dB between bursts. This is well within the requirements for DOCSIS compliance. The default variation between modems is up to 1.5 dB for most DOCSIS CMTS equipment.

- Step 4** Using the examples in [Table 4-2 on page 4-28](#) as a basis for the formula, calculate the correct center frequency offset necessary to measure the preamble peak power when viewed in a narrow bandwidth. In the example, the channel width is 1.6 MHz, which has a symbol rate of 1280 ksym/sec; therefore, the appropriate offset value is 640 kHz.
- Step 5** Change the center frequency on the spectrum analyzer by this offset value (33.248 MHz in the example) and check to see that the preamble has regained its lost amplitude by comparing it to the amplitude of the rest of the signal. If so, the spectrum analyzer should display a signal similar to the one in [Figure 4-40](#).



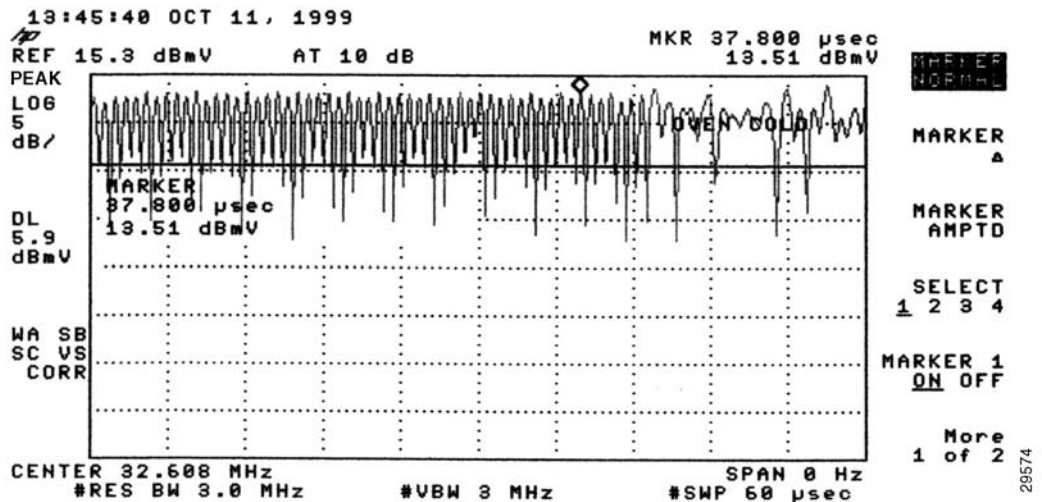
Figure 4-40 Preamble Amplitude Recovery After Center Frequency Adjustment



To get an even better look at the patterns and dramatic shifts in amplitude within the preamble itself, you can accelerate the sweep time for your zero-span signal processing.

- Step 6** Tune the spectrum analyzer to the original center frequency (32.608 MHz in this example).
- Step 7** Reset both the resolution and video bandwidth of the signal back to 3 MHz, but reduce the sweep time from 200 microseconds to 60 microseconds. The resulting display, similar to Figure 4-41, clearly shows the “tight” pattern of the preamble stretched across three-quarters of the spectrum analyzer display.

Figure 4-41 Original Preamble Viewed with Accelerated Sweep Time

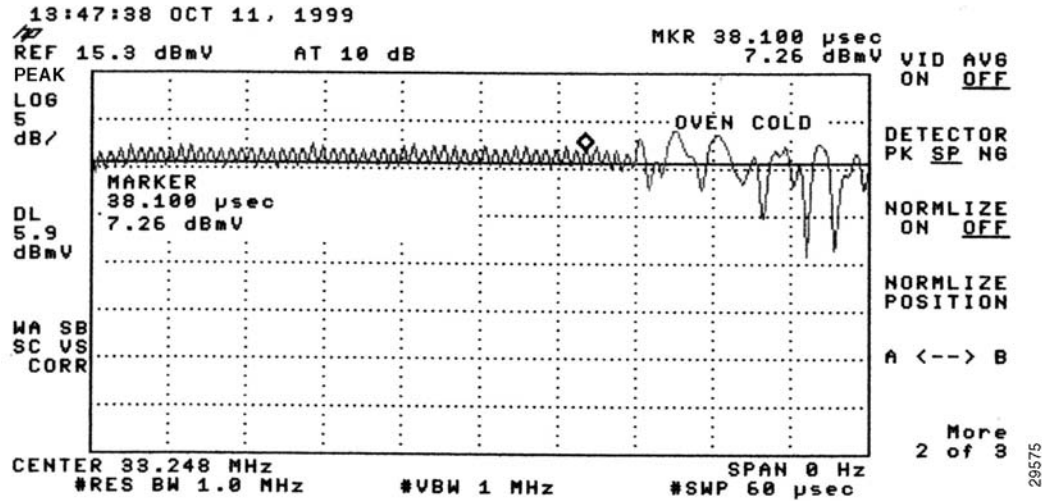


- Step 8** Change the center frequency back to 33.248 MHz and both the resolution and video bandwidth values to 1 MHz, retaining the new sweep time of 60 microseconds. The peak amplitude is clearly displayed with approximately 4.25 dB difference between the preamble and the rest of the upstream data transmission. (See Figure 4-42.)

  
**Note**

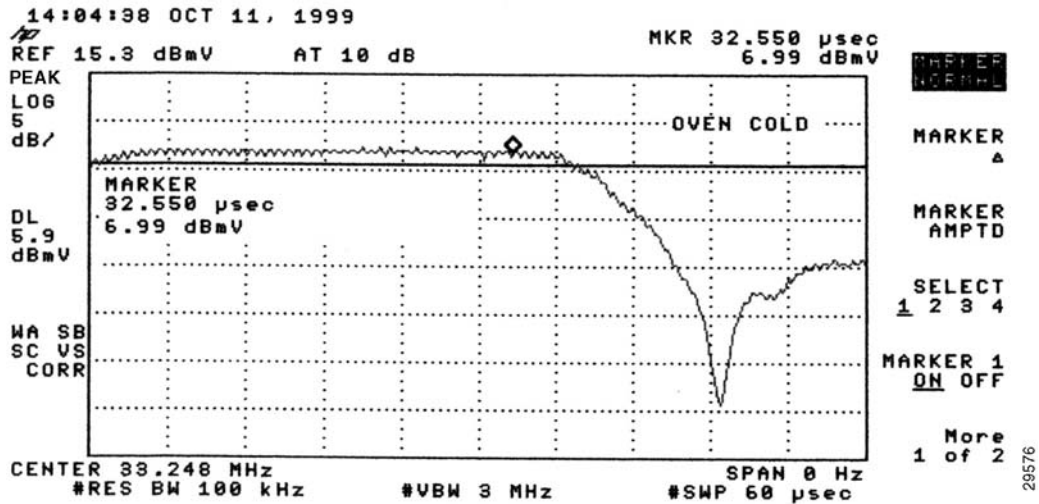
The 4.25 dB decrease in amplitude is due to a combination of half of the channel bandwidth (3 dB) and an additional 1.25 dB decrease attributed to the digital channel filter mask, known as the “alpha.” The value of alpha is 25 percent of an upstream DOCSIS channel’s width, and the peak signal energy spread across the entire upstream channel width.

**Figure 4-42 Preamble with Decreased Amplitude and Condensed Sweep Time**



**Step 9** Narrow the resolution bandwidth from 1 MHz to 100 kHz and *increase* the video bandwidth to 3 MHz, still retaining the 60 microseconds sweep time. Your spectrum analyzer should display a signal similar to [Figure 4-43](#).

**Figure 4-43 Very Narrow Resolution Bandwidth Limits Range of Spectrum Analysis**



**Note**

The slight “ramp-up” at the beginning of the preamble when viewed in this mode is attributed to the time required to charge the spectrum analyzer’s detector circuit.

Figure 4-43 shows a smooth and easily measured signal amplitude, providing accurate measurement of a very fast burst upstream carrier. You can compare the measurements obtained using a spectrum analyzer with those of specialized test equipment. In general, the readings from the spectrum analyzer will be within 1 to 2 dB of the (more expensive) specialized equipment. Because 1 to 2 dB is well within the calibration accuracy of spectrum analyzers, you can reliably use these procedures in the cable headend environment.

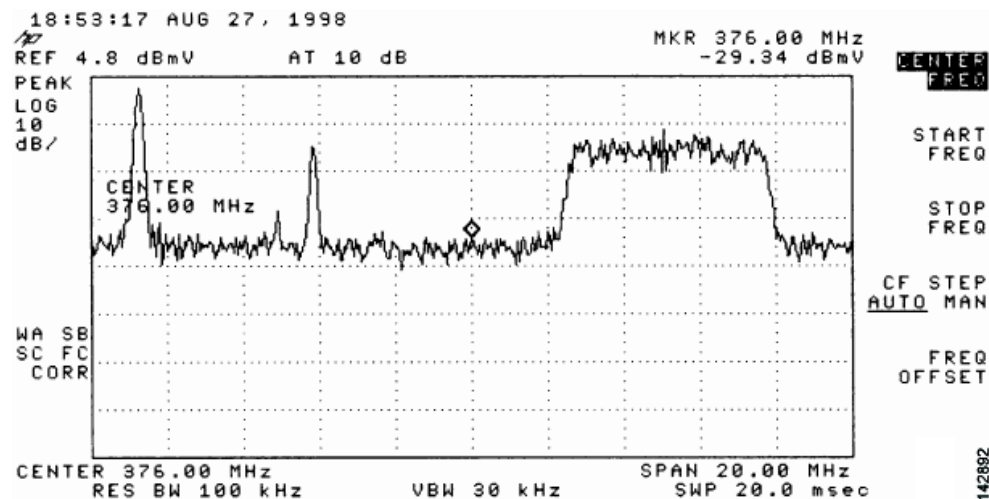
## Measuring the RF Signal at the Forward Test Point on a Laser Transmitter

This section describes RF signal measurements that should be taken with a spectrum analyzer at the downstream forward test point on the fiber-optic laser transmitter.

Use the following steps to measure the downstream forward test point on the fiber-optic laser transmitter:

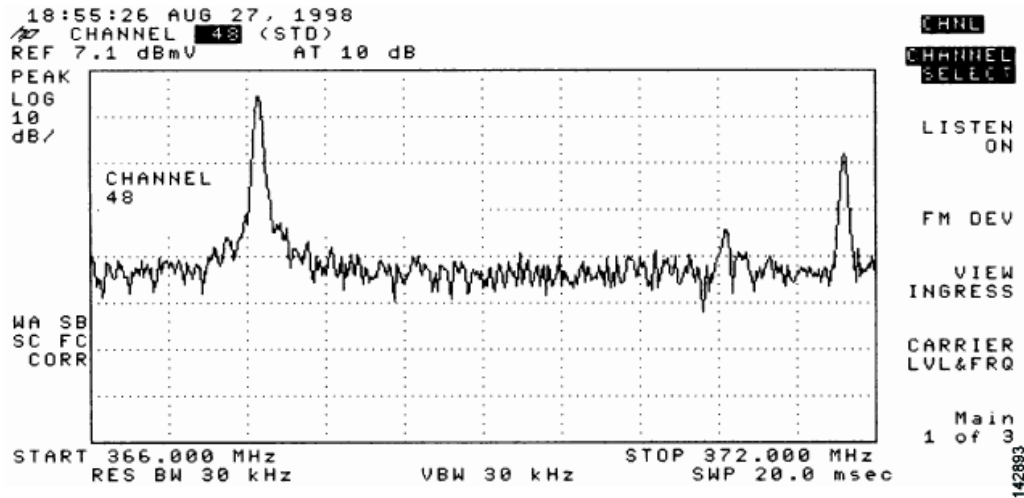
- Step 1** Connect the spectrum analyzer to the downstream forward test point on the fiber-optic laser transmitter. Figure 4-44 shows a typical measurement of the downstream forward test point.

**Figure 4-44** *Measuring the RF Signal at the Downstream Forward Test Point on the Laser Transmitter*



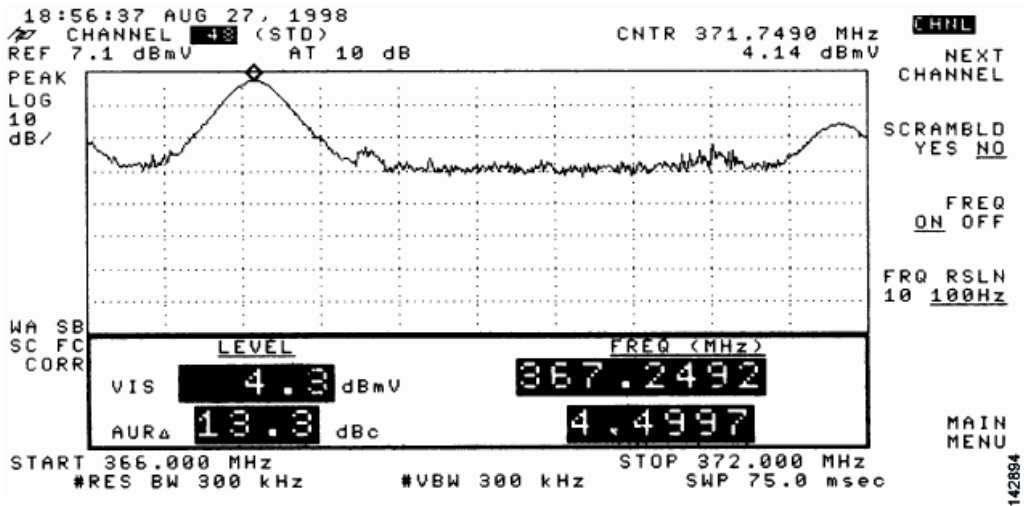
- Step 2** Using the spectrum analyzer zoom feature, zoom the display on the first individual video channel. In the example in Figure 4-45, the first video channel is channel 48.

Figure 4-45 Downstream Forward Test Point on the Laser Transmitter—Video Channel Display

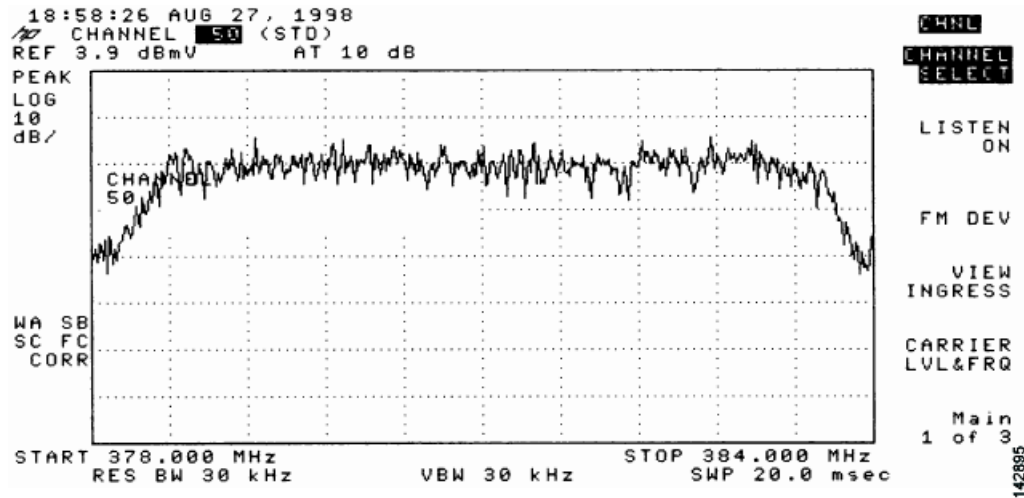


- Step 3** Select the carrier level (or amplitude) function. Figure 4-46 shows the detailed display of the analog carrier level and frequency screen for the channel 48 (in this example).

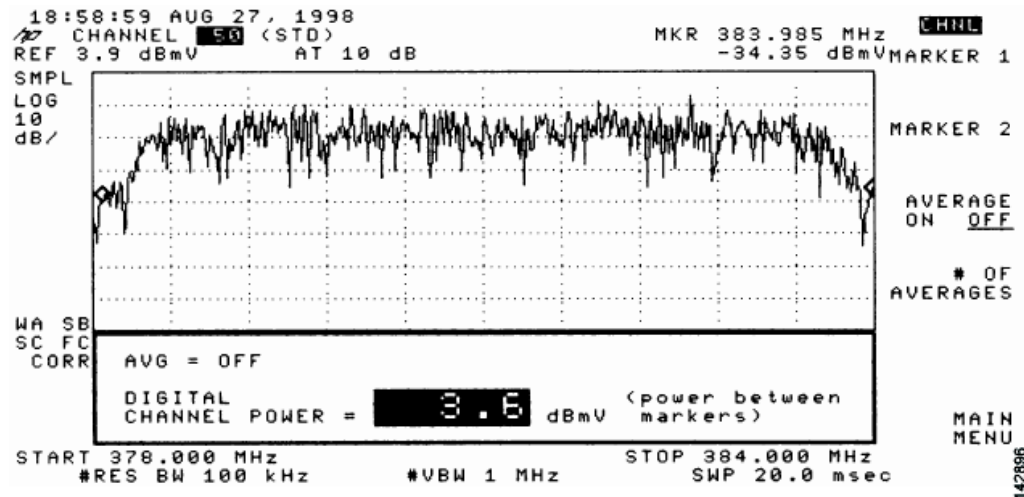
Figure 4-46 Downstream Forward Test Point on the Laser Transmitter—Detailed Video Channel Display



- Step 4** Return to the main menu on your spectrum analyzer.
- Step 5** Select a digital channel to measure. In the example in Figure 4-47, the digital channel shown is channel 50.

**Figure 4-47** Downstream Forward Test Point on the Laser Transmitter—Digital Channel Display

**Step 6** Go to the main menu on the spectrum analyzer and advance the screen displays (next screen) until the digital channel power display is shown. (See [Figure 4-48](#).)

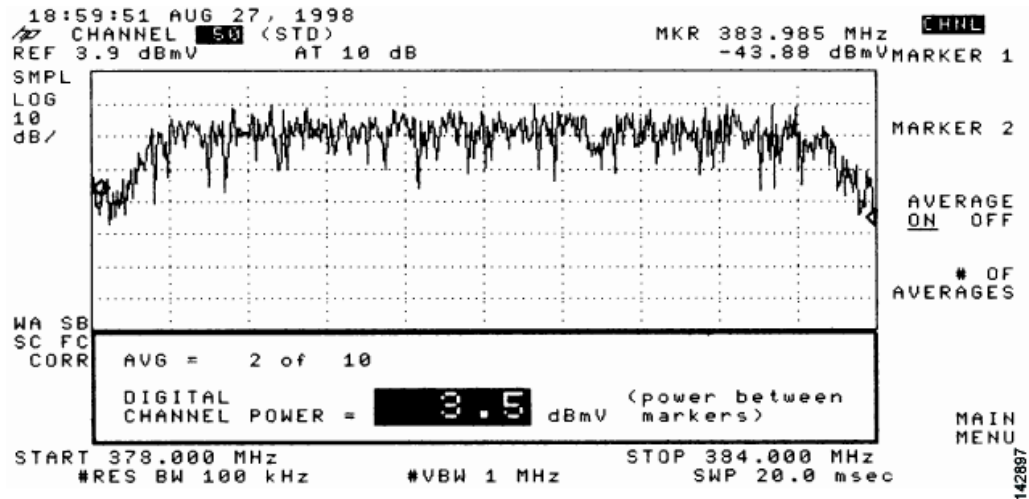
**Figure 4-48** Downstream Forward Test Point on the Laser Transmitter—Digital Channel Power Display**Note**

The +3.6 dBmV digital power rating is nearly the same as the previously measured video carrier level (+4.3 dBmV). This value is too high to provide reliable digital data transmission.

**Step 7** Set the upconverter output level so that the amplitude of the digitally modulated carrier is 6 dB to 10 dB below the amplitude found on the same frequency on an analog TV channel.

- Step 8** Select the video averaging feature to verify flatness through the headend combiner. After 10 averages, the power rating decreases by approximately 2.5 dB from actual digital channel power. While video averaging is in progress, your spectrum analyzer should display a signal similar to the one shown in Figure 4-49.

**Figure 4-49** Downstream Forward Test Point on the Laser Transmitter—Digital Channel Display Using Video Averaging



## Configuring the Digital Signal

After you have configured the RF signal, you must configure the digital data signal that will be carried between the Cisco uBR7225VXR universal broadband router and cable modems.

We recommend installing a Cisco uBR900 series cable access router at the headend to verify the digital data configuration. For instructions on how to install a Cisco uBR900 series access router, refer to the installation and configuration guides for the Cisco uBR900 series access router that you are using at the following URL:

<https://www.cisco.com/en/US/products/hw/cable/ps2221/index.html>

The output of the Cisco uBR7225VXR router is measured in RF signals through an internal upconverter. Upconverter output levels should be set to carry the digital signal data at 6 to 10 dB below the adjacent analog video signal. The value chosen is at the discretion of each cable operator.



### Note

The value chosen for the digital data in relation to the adjacent video signal must be made available to field technicians installing DOCSIS cable modem.

At a cable interface connection, this value can be measured to verify the correct operation of the cable interface.

Careful system design and operation can prevent potentially serious intermittent performance problems across your cable interface network. Each cable operator should make use of the following guidelines and practices to ensure reliable operation of any 64-QAM based digital network:

- “NCTA Recommended Practices for Measurements on Cable Television Systems” (<http://www.ncta.com>)
- Part 76 of the FCC Rules and Regulations (<http://transition.fcc.gov/oet/info/rules/>)
- DOCSIS 1.0 RF Interface Specification (<http://www.cablemodem.com>)
- DOCSIS 1.1 RF Interface Specification (<http://www.cablelabs.com/specifications/CM-SP-RFIV1.1-C01-050907.pdf>)

For example, if your headend overdrives the fiber-optic lasers transmitters, in either the upstream or downstream path, clipping may occur. Laser clipping leads to degraded signal integrity. In minor doses, this signal damage is not immediately visible on an analog video signal, but it can completely disrupt the digital transmission path. (That is, digital signals are more sensitive to clipping than analog signals and will more readily display the negative effects of laser clipping.)

If a digital signal employing forward error correction (FEC) is near its impairment limit, it is very susceptible to changes in signal level—on the order of as little as 0.1 dB. If there is no amplitude margin available in the transmission path between the headend and any one cable modem, the typical signal level variations of a properly functioning cable system (3 to 6 dB) can create intermittent service outages that are difficult to isolate.

Typical CATV measurement equipment, such as digital signal level meters, measure to an accuracy of  $\pm 1$  dB. However, some older analog meters only measure to an accuracy of  $\pm 3$  dB; therefore, maintaining 6-dB margins above the minimum levels can provide reliable long-term service.







## CHAPTER 5

# Maintaining the Cisco uBR7225VXR Router

---

This chapter describes basic maintenance for the Cisco uBR7225VXR universal broadband router and contains the following sections:

- [Online Insertion and Removal, page 5-1](#)
- [Environmental Monitoring and Reporting Functions, page 5-2](#)

## Online Insertion and Removal

The cable interface line cards and network processing engine in the Cisco uBR7225VXR universal broadband router support online insertion and removal (OIR). Technically, the Cisco uBR7225VXR universal broadband router supports true OIR, or “hot swapping,” of cable interface line cards only when exchanging cable interface line cards of the exact same type (for example, exchanging a Cisco uBR-MC28U line card for another Cisco uBR-MC28U line card). Under these conditions, no reload of the router is required.

You can remove and replace a cable interface line card with the same type of component without interrupting the system. This function allows you to install and replace the same type of cable interface cards while the router is operating.



### Note

---

To replace a cable interface line card with a different type of line card (for example, hot swapping from a Cisco uBR-MC16U to a Cisco uBR-MC28U, you must copy your startup configuration to your running configuration on the Cisco uBR7225VXR router to enable the interfaces on the new cable interface line card.

---



### Caution

---

When you use OIR for different types of cable interface line cards (for example, a Cisco uBR-MC16U line card replaced by a Cisco uBR-MC28U line card), you might have to reconfigure the interfaces, and we highly recommend that you reload the router.

---

Detailed instructions for installing Cisco cable interface cards are contained in the document *Cisco uBR7200 Series Cable Interface Line Card Hardware Installation Guide* at the following URL:  
[http://www.cisco.com/en/US/docs/interfaces\\_modules/cable/line\\_cards/installation/guide/mcxxfru.html](http://www.cisco.com/en/US/docs/interfaces_modules/cable/line_cards/installation/guide/mcxxfru.html)

**Caution**

The network processing engine cannot be removed if the router is operating. Removing the network processing engine while the Cisco uBR7225VXR router is operating causes the router to shut down or crash, and might damage or destroy memory files.

Each cable interface line card has a bus connector that connects it to the router's midplane. Each midplane connector has a set of tiered pins in three lengths. The pins send specific signals to the system as they make contact with the cable interface line card. The system assesses the signals it receives and the order in which it receives them to determine if a board is being removed or inserted into the midplane. From these signals, the system determines whether to reinitialize a new interface or shut down a removed interface. For example, when inserting a cable interface line card, the longest pins make contact with the cable interface line card first, and the shortest pins make contact last. The system recognizes the signals and the sequence in which it receives them.

When you remove or insert a cable interface line card in a Cisco uBR7225VXR router, the midplane pins send signals to notify the system, which then does the following:

1. Rapidly scans the midplane for configuration changes.
2. Initializes all newly inserted cable interface line cards, noting any removed interfaces and placing them in the administratively shutdown state.
3. Brings all previously configured interfaces on the cable interface line card back to the state they were in when it was removed. If the same type of interface card type is reinserted into a slot, its interfaces are configured and brought online up to the interface count of the original cable interface line card. If, however, any new interfaces are put in the administratively shutdown state, as if they were present (but not configured) at boot time, the system must be configured.

## Environmental Monitoring and Reporting Functions

Environmental monitoring and reporting functions are controlled by the network processing engine and allow you to maintain normal system operation by identifying and resolving adverse conditions before loss of operation. The environmental monitoring functions constantly monitor the internal chassis air temperature and AC supply voltages. Each power supply monitors its own voltage, currents, and temperature and shuts itself down if it detects a critical condition within the power supply. If conditions reach shutdown thresholds, the system shuts down to avoid equipment damage from excessive heat. The reporting functions periodically log the values of measured parameters so that you can retrieve them for analysis later, and the reporting functions display warnings on the console if any of the monitored parameters exceed defined thresholds.

### Environmental Monitoring

The environmental monitoring functions use the following five levels of status conditions to monitor the system. Two sensors on the network processing engine monitor the temperature of the cooling air as it moves through the chassis.

- Normal—All monitored parameters are within normal tolerances.
- Warning—The system has exceeded a specified threshold. The system continues to operate, but we recommend operator action to bring the system back to a normal state.
- Critical—An out-of-tolerance temperature or voltage condition exists. The system continues to operate; however, the system is approaching shutdown. Immediate operator action is required.

- Shutdown—The processor has detected a temperature condition that could result in physical damage to system components and has disabled DC power to all internal components. Requires immediate operator action. Before any shutdown, the system logs the status of monitored parameters in NVRAM so that you can retrieve it later to help determine the cause of the problem. The power supply repeatedly attempts to restart itself within 90 seconds to clear the temperature condition.
- Power supply shutdown—The power supply detected an internal out-of-tolerance overvoltage, overcurrent, or temperature condition and shut itself down. The power supply repeatedly attempts to restart itself within 90 seconds to clear the shutdown condition.

Table 5-1 lists the temperature thresholds for the processor-monitored levels.

**Table 5-1** Typical Processor-Monitored Temperature Thresholds for the Cisco uBR7225VXR

Parameter	High Warning	High Critical	Shutdown
NPE Inlet	111°F (44°C)	138°F (59°C)	176°F (80°C)
NPE Outlet	120°F (49°C)	147°F (64°C)	183°F (84°C)
MP NPE Inlet	120°F (49°C)	147°F (64°C)	183°F (84°C)
MP NPE	120°F (49°C)	147°F (64°C)	183°F (84°C)
MP LC Inlet	105°F (41°C)	132°F (56°C)	168°F (76°C)
MP LC	107°F (42°C)	134°F (57°C)	170°F (77°C)

Temperature sensors are located on the NPE Inlet and NPE Outlet. See the appropriate chapter for your NPE in the *Network Processing Engine and Network Services Engine Installation and Configuration* document for their exact locations. Temperature MP NPE Inlet is located on NPE side of the inlet edge of the midplane. Temperature MP LC Inlet is located on line card side of the inlet edge of the midplane. Temperature MP NPE is located on NPE side of the middle of the midplane. Temperature MP LC is located on line card side of the middle of the midplane.

If the air temperature exceeds a defined threshold, the system controller displays warning messages on the console terminal and, if the temperature exceeds the shutdown threshold, it shuts down the system. The system stores the present parameter measurements for both temperature and DC voltage in NVRAM so that you can retrieve them later as a report of the last shutdown parameters.

The power supplies monitor internal power supply temperature and voltages. A power supply is either within tolerance (normal) or out of tolerance (critical). If an internal power supply temperature or voltage reaches a critical level, the power supply shuts down without any interaction with the system processor.

## Reporting Functions

The Cisco uBR7225VXR router displays warning messages on the console if chassis interface-monitored parameters exceed a desired threshold. You can also retrieve and display environmental status reports with the **show environment**, **show environment all**, **show environment last**, and **show environment table** commands. Parameters are measured and reporting functions are updated every 60 seconds. A brief description of each of these commands follows.

**Caution**

To prevent overheating the chassis, ensure that your system is drawing cool inlet air. Overtemperature conditions can occur if the system is drawing in the exhaust air of other equipment. Ensure adequate clearance around the sides of the chassis so that cooling air can flow through the chassis interior unimpeded and exhaust air exits the chassis and is not drawn into the inlet vent of other devices.

The **show environment** command display reports the current environmental status of the system. The report displays parameters that are out of the normal values. No parameters are displayed if the system status is normal. The example that follows shows the display for a system in which all monitored parameters are within normal range:

```
Router# show environment

All measured values are normal
```

If the environmental status is *not* normal, the system reports the worst-case status level. Following is an example overvoltage warning:

```
Router# show environment

Warning: +3.45 V measured at +3.83 V
```

The **show environment last** command retrieves and displays the NVRAM log, which shows the reason for the last system shutdown (if the shutdown was related to voltage or temperature) and the environmental status at that time. Air temperature is measured and displayed, and the DC voltage supplied by the power supply is also displayed.

Following is sample output of the **show environment last** command for a Cisco uBR7225VXR router:

```
Router# show environment last

NPE Inlet previously measured at 26C/78F
NPE Outlet previously measured at 29C/84F
MP NPE Inlet previously measured at 24C/75F
MP NPE previously measured at 30C/86F
MP LC Inlet previously measured at 27C/80F
MP LC previously measured at 30C/86F
CPU Die previously measured at 45C/113F
+3.30 V previously measured at +3.28
+1.50 V previously measured at +1.49
+2.50 V previously measured at +2.48
+1.80 V previously measured at +1.78
+1.20 V previously measured at +1.19
VDD_CPU previously measured at +1.27
VDD_MEM previously measured at +2.48
VTT previously measured at +1.24
+3.45 V previously measured at +3.49
-11.95 previously measured at -11.79
+5.15 V previously measured at +5.00
+12.15 V previously measured at +11.71
+1.2 V(MP NPE) previously measured at +1.19
+1.8 V(MP NPE) previously measured at +1.81
+3.45 V(MP NPE) previously measured at +3.56
+5.15 V(MP NPE) previously measured at +5.27
+12 V(MP NPE) previously measured at +11.81
-12 V(MP NPE) previously measured at -12.00
+5.15 V(MP LC) previously measured at +5.27
+12 V(MP LC) previously measured at +11.81
last shutdown reason - power supply shutdown
```

The **show environment table** command displays the temperature and voltage thresholds for each temperature sensor and for each monitored status level, which are related to those thresholds listed in [Table 5-1](#). The display also lists the shutdown threshold for the system. You can abbreviate the command to **sh env table**.

Following is sample output of the **show environment table** command for a Cisco uBR7225VXR router:

```
Router# show environment table

Sample Point      LowCritical  LowWarning  HighWarning  HighCritical

NPE Inlet  44C/111F59C/138F80C/176F
NPE Outlet 49C/120F64C/147F84C/183F
MP NPE Inlet 49C/120F64C/147F84C/183F
MP NPE 49C/120F64C/147F84C/183F
MP LC Inlet 41C/105F56C/132F76C/168F
MP LC 42C/107F57C/134F77C/170F
CPU Die 90C/194F 105C/221F110C/230F
+3.30 V +2.30+3.12 +3.47 +4.29
+1.50 V +1.05+1.40 +1.57 +1.95
+2.50 V +1.71+2.34 +2.65 +3.28
+1.80 V +1.25+1.67 +1.91 +2.34
+1.20 V +0.82+1.13 +1.28 +1.56
VDD_CPU +0.89+1.21 +1.36 +1.71
VDD_MEM +1.71+2.34 +2.65 +3.28
VTT +0.85 +1.17 +1.32 +1.64
+3.45 V +2.42+3.24 +3.63 +4.49
-11.95 -7.14 -9.54 -14.28 -16.12
+5.15 V +3.63+4.84 +5.46 +6.75
+12.15 V +8.55+11.36+12.89+14.94
+1.2 V(MP NPE)+1.01+1.12+1.26+1.37
+1.8 V(MP NPE)+1.51+1.67+1.90+2.05
+3.45 V(MP NPE)+3.00+3.31+3.77+4.08
+5.15 V(MP NPE)+4.46+4.92+5.55+5.96
+12 V(MP NPE)+10.13+11.22+12.65+13.74
-12 V(MP NPE)-13.87-13.29-10.83-10.24
+5.15 V(MP LC)+4.44+4.91+5.56+6.03
+12 V(MP LC)+10.18+11.25+12.68+13.81
```

**Note**

Temperature ranges and values are subject to change.

The **show environment all** command displays an extended report that includes temperature readings and voltage readings. The **show environment all** command also displays a report showing which power supply slots are occupied and which are empty.

Following is sample output of the **show environment all** command for a Cisco uBR7225VXR router:

```
Router# show environment all

Power Supplies:
  Power Supply 1 is AC C49-300. Unit is on.
  Power Supply 2 is empty.

Temperature readings:
  NPE Inlet measured at 25C/77F
  NPE Outlet measured at 29C/84F
  MP NPE Inlet measured at 23C/73F
  MP NPE measured at 30C/86F
  MP LC Inlet measured at 28C/82F
  MP LC measured at 31C/87F
  CPU Die measured at 45C/113F
```

```

Voltage readings:
+3.30 V measured at +3.28 V
+1.50 V measured at +1.49 V
+2.50 V measured at +2.48 V
+1.80 V measured at +1.78 V
+1.20 V measured at +1.19 V
VDD_CPU measured at +1.27 V
VDD_MEM measured at +2.48 V
VTT measured at +1.24 V
+3.45 V measured at +3.49 V
-11.95 measured at -11.79 V
+5.15 V measured at +5.00 V
+12.15 V measured at +11.71 V
+1.2 V(MP NPE) measured at +1.19 V
+1.8 V(MP NPE) measured at +1.81 V
+3.45 V(MP NPE) measured at +3.56 V
+5.15 V(MP NPE) measured at +5.27 V
+12 V(MP NPE) measured at +11.81 V
-12 V(MP NPE) measured at -12.00 V
+5.15 V(MP LC) measured at +5.27 V
+12 V(MP LC) measured at +11.81 V

```

```

Fans:
NPE Fan 1 is working
NPE Fan 2 is working
NPE Fan 3 is working
LC Fan 1 is working
LC Fan 2 is working
LC Fan 3 is working

```

```

Envm stats saved 2 time(s) since reload

```

## Fan Failures

When the system power is on, the Cisco uBR7225VXR router fans should be operational. The system continues to operate if a fan fails; however, if the air temperature exceeds a defined threshold, the system controller displays warning messages on the console terminal and, if the temperature exceeds the shutdown threshold, it shuts down the system.

If the system does shut down because the temperature exceeded the shutdown threshold, the system displays the following message on console screen and in environment display when the system restarts:

```

Queued messages:
%ENVM-1-SHUTDOWN: Environmental Monitor initiated shutdown

```

For complete descriptions and instructions for the environmental monitor commands, refer to the following documents:

*Cisco IOS CMTS Command Reference Guide* at the following URL:

[http://www.cisco.com/en/US/docs/interfaces\\_modules/cable/line\\_cards/installation/guide/mcxxfru.html](http://www.cisco.com/en/US/docs/interfaces_modules/cable/line_cards/installation/guide/mcxxfru.html)

*Cisco IOS CMTS Cable Software Configuration Guide* at the following URL:

[http://www.cisco.com/web/techdoc/cable/Config/Sw\\_conf.html](http://www.cisco.com/web/techdoc/cable/Config/Sw_conf.html)

*Cisco IOS Configuration Fundamentals Command Reference* at the following URL:

[http://www.cisco.com/en/US/docs/ios/12\\_2/configfun/command/reference/ffun\\_r.html](http://www.cisco.com/en/US/docs/ios/12_2/configfun/command/reference/ffun_r.html)



## CHAPTER 6

# Troubleshooting

---

This chapter provides troubleshooting information for the Cisco uBR7225VXR universal broadband router and contains the following sections:

- [Overview, page 6-1](#)
- [Problem Solving with Subsystems, page 6-2](#)
- [Power Subsystem, page 6-4](#)
- [Cooling Subsystem, page 6-4](#)
- [Processor Subsystem, page 6-5](#)
- [Verifying the Downstream Signal, page 6-7](#)

## Overview

This chapter contains instructions to help installers and technicians troubleshoot hardware installation.

[Figure 6-1](#) shows the general troubleshooting strategy used to troubleshoot the hardware. Refer to this flow chart as necessary and follow the steps to isolate hardware problems to a specific subsystem.

For cable-specific commands for the Cisco uBR7225VXR universal broadband router, refer to the *Cisco IOS CMTS Cable Command Reference Guide* at the following URL:

[http://www.cisco.com/en/US/docs/ios/cable/command/reference/cbl\\_book.html](http://www.cisco.com/en/US/docs/ios/cable/command/reference/cbl_book.html)

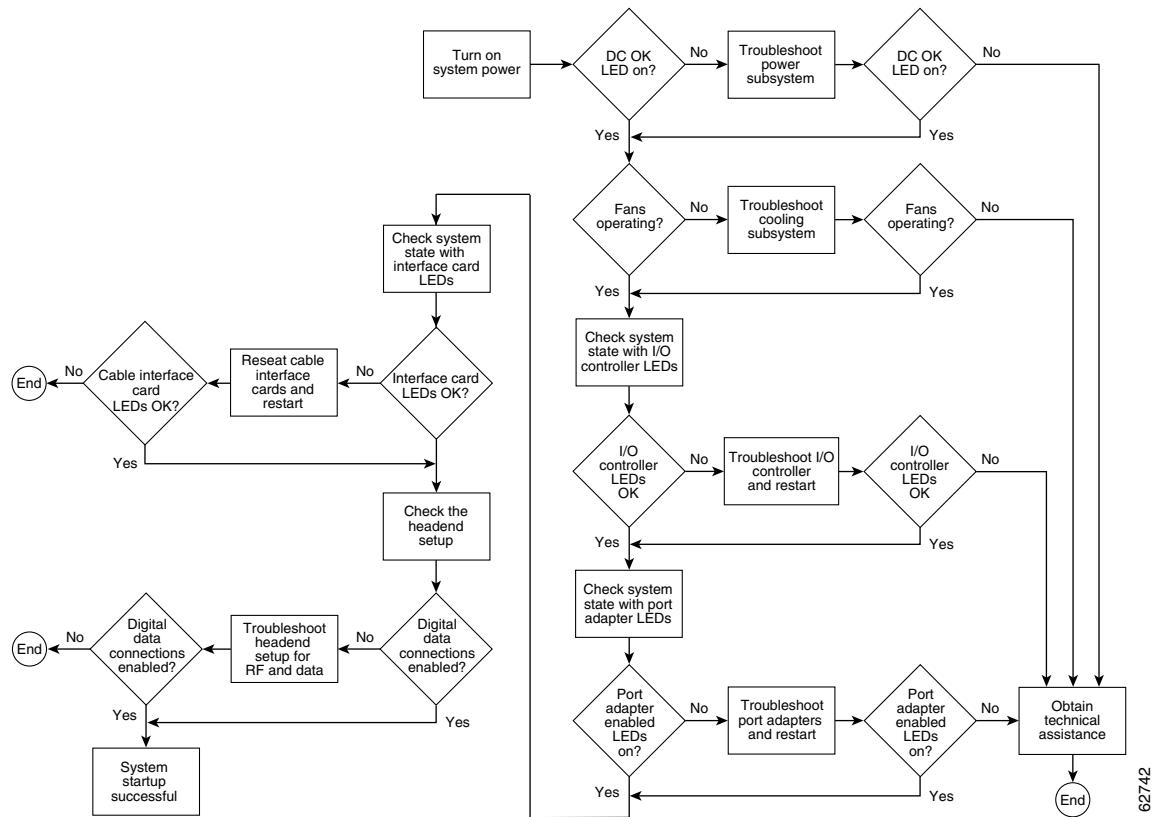
Resolve the problem if possible or contact the Cisco Technical Assistance Center.

## Providing Information

If you are contacting Cisco TAC or your customer service representative, provide the following information:

- Date you received your Cisco uBR7225VXR universal broadband router
- Chassis serial number
- Type of software and release number
- Brief description of the problem you are having
- Brief explanation of the steps you have taken to isolate and resolve the problem
- Maintenance agreement or warranty information

Figure 6-1 Troubleshooting Strategy for Startup Problems



## Problem Solving with Subsystems



### Tip

Isolating a problem to a specific subsystem simplifies the troubleshooting process.

The first step in isolating a problem is to compare what the system *is doing* to what it *should be doing*. Usually a startup problem is caused by a single component, so first isolating the problem to a subsystem rather than troubleshooting every component in the entire system is more efficient. The Cisco uBR7225VXR router subsystems are listed below.

- Power subsystem—Includes the power supplies, the external power cable, and the midplane.
- Cooling subsystem—The chassis fan tray is the single component in this subsystem. The fans should be operating whenever system power is on.
- Processor subsystem—Includes the network processing engine and cable interface line cards.

The system memory and management functions reside on the network processing engine. The enabled LED on each cable interface line card indicates if the cable interface line card is initialized.



### Caution

A cable interface line card that is partially installed in the midplane can cause the system to hang and crash.



- Cable headend subsystem—External to the Cisco uBR7225VXR router, this subsystem can prevent operation of the universal broadband router if the headend is not properly set up for the introduction of digital data into the hybrid fiber-coaxial (HFC) network.

The following section helps you isolate a problem to one of the subsystems and directs you to the appropriate troubleshooting section.

## Identifying Startup Problems

When you start up the Cisco uBR7225VXR router for the first time, observe the startup sequence described in the [“Powering On the Cisco uBR7225VXR Router”](#) section on page 3-18. This section contains a detailed description of the normal startup sequence.

Although an overtemperature condition is unlikely at initial startup, the environmental monitoring functions are included in this chapter because they also monitor internal voltages.

Startup problems are commonly caused by source power problems or a board (network processing engine or cable interface line card) that is not properly connected to the midplane. Always check that your boards are properly installed in the chassis.

With the exception of the fan tray and network processing engine, LEDs indicate all system states in the startup sequence. By checking the state of the LEDs, you can determine when and where the system failed in the startup sequence.



### Note

---

On rare occasions, an LED may be faulty.

---

Use the following descriptions to isolate the problem to a subsystem, then proceed to the appropriate sections to try to resolve the problem. When you start up the system, by turning on the power supply switch, the following should occur:

1. You should immediately hear the fans operating. If not, proceed to the [“Cooling Subsystem”](#) section on page 6-4. If you determine that the power supply is functioning normally and that a fan is faulty, contact a customer service representative. If a fan does not function properly at initial startup, there are no installation adjustments that you should make.
2. The power supply’s green Input OK LED (at the rear of the chassis) should go on immediately when you place the power supply switch in the ON (I) position, and should remain on during normal system operation. If the green Input OK LED *does not* go on, proceed to the [“Power Subsystem”](#) section on page 6-4.
3. The enabled LED on each cable interface line card comes on when the network processing engine completes its initialization of the card for operation. The enabled LED indicates that the line card is receiving power and has been recognized by the network processing engine; it does not indicate the state of the individual interfaces on the card. If an enabled LED fails to come on, refer to the [“Troubleshooting Cable Interface Line Cards”](#) section on page 6-6.
4. When all LEDs come on to indicate that the system has booted successfully, the initial system banner should appear on the console screen. If it is not displayed, refer to the [“Console and Auxiliary Port Connection Equipment”](#) section on page 3-14 to verify that the terminal is set correctly and that it is properly connected to the console port on the NPE.

# Power Subsystem

Check the following to help isolate a problem with the power subsystem:

---

- Step 1** Toggle the power supply switch off and on.
- Step 2** On the first power supply, is the Input OK LED on?
- If yes, the power source is good, and the power supply is functional.
  - If not, make sure that the power cable is connected at both ends. Then toggle the power switch off and on.
- Step 3** If the Input OK LED remains off, and the power switch is on, suspect the power source or the power cable.
- Turn the switch off, and connect the power cable to another power source, if available.
  - Turn the switch back on.
  - If the Input OK LED comes on, the problem is the first power source.
- Step 4** If the Input OK LED fails to come on after you connect the power supply to a new power source,
- Turn the power switch off.
  - Replace the power cord.
  - Turn the switch back on.
- Step 5** If the Input OK LED comes on, return the first power cable for replacement. Contact a service representative for further instructions.
- Step 6** If the Input OK LED still fails to come on when the power supply is connected to a different power source with a new power cable, the power supply is probably faulty.
- If a second power supply is available, and your Cisco uBR7225VXR router has a redundant power supply bay, install the second power supply in the second bay if there is no power supply installed in that bay.
  - Contact a service representative for further instructions.
- Step 7** Is the Input OK LED on for the second (redundant) power supply?
- If yes, proceed to the [“Cooling Subsystem”](#) section on page 6-4.
  - If not, repeat each of the above procedures for the second power supply.
- Step 8** If you are unable to resolve the problem or if you determine that either a power supply or chassis connector is faulty, contact a service representative for instructions.
- 

# Cooling Subsystem

Check the following to help isolate a problem with the cooling system:

---

- Step 1** Verify that the fans are operating when you start up the system.

To determine if the fans are operating, listen for them. In noisy environments, place your hand on the left side of the chassis (when viewing the chassis from the front) to feel for air being forced out the vents.

- a. If yes, the power to the fan tray is good.
- b. If no, there is a problem with the fan tray or power. See the “[Power Subsystem](#)” section on page 6-4.

**Step 2** Verify that the following message is **not** displayed.

```
Queued messages:  
%ENVM-1-SHUTDOWN: Environmental Monitor initiated shutdown
```

If the message is displayed, the system has detected an overtemperature condition or power out-of-tolerance condition inside the chassis.

The shutdown message could also indicate a faulty component or temperature sensor. Before the system shuts down, use the **show environment** or **show environment table** command to display the internal chassis environment.

If an environmental shutdown results from a power out-of-tolerance condition, the power OK LEDs goes off and the system shuts down. See the “[Power Subsystem](#)” section on page 6-4.

**Step 3** Although an overtemperature condition is unlikely at initial startup, ensure that heated exhaust air from other equipment is not entering the inlet vent on the router and that there is sufficient clearance around the sides of the chassis to allow cooling air to flow. Refer to the “[Site Environment](#)” section on page 2-5 and the “[Equipment Racks](#)” section on page 2-15 for more on site configurations.

## Processor Subsystem

The processor subsystem is comprised of the network processing engine and all cable interface cards. The network processing engine is a required system component. The system cannot operate unless the network processing engine is installed properly; however, the system can operate without any cable interface card installed.



### Note

The network processing engine (NPE-G1 or NPE-G2) used in Cisco uBR7225VXR allows the router to work without an I/O controller. NPE-G1 and NPE-G2 works with both Cisco uBR7225 and Cisco uBR7246 chassis.

If a cable interface card is partially connected to the midplane, the card sends connection incomplete signals to the processor, which then faults the peripheral component interconnect (PCI) bus and causes the system to hang.

Therefore, first ensure that the network processing engine is installed properly and the system software has initialized successfully. Then, if necessary, you can troubleshoot individual cable interface cards.

## Troubleshooting the Network Processing Engine

Check the following to help isolate a problem with the network processing engine (NPE):

**Step 1** If the NPE enabled LED does not go on as expected:

- a. Turn off the power to the router.

- b. Reseat the network processing engine in its slot.
  - c. Restart the router.
- Step 2** Verify that you are running a version of Cisco IOS software that supports the NPE you are using:
- a. For the latest Cisco IOS software release information, refer to the Cisco uBR7200 series release notes at the following URL:  
[http://www.cisco.com/en/US/products/hw/cable/ps2217/prod\\_release\\_notes\\_list.html](http://www.cisco.com/en/US/products/hw/cable/ps2217/prod_release_notes_list.html)
  - b. Use the **show version** command to determine the NPE that is installed in your router.
  - c. If the router does not respond to the console input, contact Cisco TAC for instructions.
- Step 3** If the enabled LED remains off, the system detected a processor hardware failure. This LED should be on in normal operation. Contact Cisco TAC for instructions.
- 

## Troubleshooting Cable Interface Line Cards

Check the following to help isolate a problem with the cable interface line cards:

---

- Step 1** Verify that *all* cable interface card enabled LEDs are on. If yes, the system is operational.
- Step 2** Check to see if *all* cable interface line card enabled LEDs are off.
- a. If yes, verify that you are running a version of Cisco IOS software that supports the cable interface line cards you are using.  
  
For the latest Cisco IOS software release information, refer to the Cisco uBR7200 series release notes, at the following URL:  
[http://www.cisco.com/en/US/products/hw/cable/ps2217/prod\\_release\\_notes\\_list.html](http://www.cisco.com/en/US/products/hw/cable/ps2217/prod_release_notes_list.html)  
  
For the latest information on supported features, refer to the Cisco uBR7200 series software feature guides at the following URL:  
[http://www.cisco.com/en/US/products/hw/cable/ps2217/products\\_feature\\_guides\\_list.html](http://www.cisco.com/en/US/products/hw/cable/ps2217/products_feature_guides_list.html)
  - b. If the Cisco IOS software is correct, contact Cisco TAC for instructions.
- Step 3** Check to see if *any* cable interface line card enabled LEDs are off.
- a. If the enabled LED on an individual cable interface line card is off, check to see if the cable interface line card has pulled away from the midplane.
  - b. Reseat the cable interface line card in its slot. (You do not have to turn off the system power when removing or replacing cable interface line cards.)
  - c. After the system reinitializes the interfaces, the enabled LED on the cable interface line card should come on.
- Step 4** If the enabled LED remains off, the system detected a processor hardware failure. This LED should be on in normal operation. Contact Cisco TAC for instructions.
-

## Other Troubleshooting Information Websites

These websites are provided to help you find the most current troubleshooting information:

- Search the Cisco TAC assistance website, at the following URL:  
<http://www.cisco.com/en/US/support/index.html>
- Search cable products field notices at the following URL:  
[http://www.cisco.com/en/US/support/tsd\\_products\\_field\\_notice\\_summary.html](http://www.cisco.com/en/US/support/tsd_products_field_notice_summary.html)
- Find router and Cisco IOS architecture technical tips at the following URL:  
[http://www.cisco.com/en/US/products/hw/routers/ps341/prod\\_tech\\_notes\\_list.html](http://www.cisco.com/en/US/products/hw/routers/ps341/prod_tech_notes_list.html)

## Verifying the Downstream Signal

If the Cable Modem Termination System (CMTS) has not been properly set up to support digital data, the Cisco uBR7225VXR router might start up, but fail to support data transmission. You can use a router with diagnostic capabilities, such as the Cisco uBR900 series cable access routers, to verify the downstream signal originating from a Cisco uBR7225VXR router. The Cisco uBR900 series cable access routers are equipped with 64- and 256-QAM receivers that require only minimal setup. Configure the Cisco uBR900 series routers according to DOCSIS practices.

**Tip**

A maximized signal-to-noise ratio (SNR) estimate optimizes cable interface reliability and service quality.

**Note**

The SNR estimate for a cable interface installed at the headend should be between 35 and 39 dB.

Before starting this procedure:

- Connect the Cisco uBR7225VXR router to the console. See the “[Console and Auxiliary Port Connection Equipment](#)” section on page 3-14.
- Set up the console. See the *Cisco uBR7200 Series Software Configuration Guide* at the following URL:  
<http://www.cisco.com/en/US/docs/cable/cmts/ubr7200/configuration/guide/cr72scg.html>

To verify the downstream signal originating from the Cisco uBR7225VXR router:

**Step 1**

When the Cisco uBR900 series cable access router is operating and you have established an input signal of between  $-10$  and  $+10$  dBmV on the modem, enter the **show controllers cable-modem 0** command. This command displays:

- Signal-to-noise ratio (SNR)
- Downstream signal frequency
- Downstream signal modulation scheme (64 QAM or 256 QAM)

Example:

```
Router# show controllers cable-modem 0
Tuner:status=0x00
Rx:tuner_freq 555000000, symbol_rate 5055926, local_freq 11520000
```

```
snr_estimate 352(TenthdB), ber_estimate 0, lock_threshold 26000
QAM in lock, FEC in lock, qam_mode QAM_64
```

This shows a downstream frequency of 555 MHz, 64-QAM downstream, and an SNR estimate of 35.2 dB.

**Note**

Use the **debug cable mac log verbose** and **show controllers cable 0 mac state** commands when troubleshooting the cable interface's initialization sequence and locking on the downstream signal.

**Step 2**

Scan the output for the value corresponding to the "SNR\_estimate" variable. If this value is at least 35 dB, then you have an optimized signal. If the value is less than 34 dB, you must adjust the cable interface line card.

- a. Verify that the line card DS output level is correct (+32 dBmV or +42 dBmV).
- b. Make sure that the Cisco uBR7225VXR line card IF input to the upconverter is within an acceptable range (check the upconverter manufacturer's specifications).
- c. Check the upconverter RF output level. A typical setting is +55 to +58 dBmV.
- d. Make sure that the upconverter RF output center frequency has been set correctly.
- e. Make sure that the proper amount of attenuation has been installed between the upconverter RF output and the headend combiner input so that the digitally modulated carrier's average power level is 6 dB to 10 dB below the level of the analog TV channels.
- f. Make sure that the digitally modulated carrier's RF average power level is in the -15 dBmV to +15 dBmV range at the input to the cable router.

**Note**

The exact value displayed will vary from cable interface to cable interface; however, the values collected from measurement to measurement on the same router will be consistent.

**Step 3**

If the previous steps do not identify the problem, check the downstream digitally modulated carrier using a QAM analyzer. Several third-party test equipment manufacturers have these instruments available.

- a. Measure modulation error ratio (MER), which should be 35 dB or greater in the headend.
- b. Check pre- and post-FEC bit error rate (BER). There should be no bit errors in the headend. If bit errors are observed, one likely cause is sweep transmitter interference.
  - Check the sweep transmitter to make sure that adequate guard bands have been programmed around the digitally modulated carrier.
  - Bit errors also may be caused by clipping of the digitally modulated carrier in the upconverter or other active device, including amplifiers and optical transmitters.
- c. Evaluate the digitally modulated carrier's constellation. Look for evidence of:
  - Gain compression
  - Phase noise
  - Inphase and quadrature (I-Q) imbalance
  - Coherent interference
  - Excessive noise
  - Clipping



# APPENDIX **A**

## Cisco uBR7225VXR Router Specifications

This appendix provides information on the Cisco uBR7225VXR universal broadband router physical and system specifications.

### Cisco uBR7225VXR Physical and System Specifications

[Table A-1](#) lists the Cisco uBR7225VXR physical specifications, power requirements, and software compatibility.

**Table A-1** *Cisco uBR7225VXR Physical Specifications*

Description	Specification
Midplane	Two primary PCI buses and one secondary PCI bus with an aggregate bandwidth of 600 Mbps
Dimensions (H x W x D)	3.5 x 17.32 x 21.875 in. (8.89 x 43.99 x 55.56 cm)
Weight	Chassis fully configured with a network processing engine and 2 power supplies: ~ 48 pounds (21.8 kg)
Heat dissipation	370W <sup>1</sup> (1262 Btu <sup>2</sup> )
Power dissipation	370W (1262 Btu)
AC-input power	300W maximum (for a 300W AC-input with either a single or dual power supply configuration) 540W maximum (for a 540W AC-input with either a single or dual power supply configuration)
Maximum AC-input voltage	100 to 240 VAC <sup>3</sup> wide input with power factor correction
AC-input current rating	4A-2A (for a 300W AC-input power supply) 7A-3A (for a 540W AC-input power supply)
AC-input cable	18 AWG <sup>4</sup> three-wire cable, with a three-lead IEC-320 receptacle on the power supply end, and a country-dependent plug on the power source end
Operating Frequency	50/60 Hz
Airflow	~105 cfm <sup>5</sup>
Temperature	32 to 104°F (0 to 40°C)
Humidity	10 to 90% noncondensing

**Table A-1** Cisco uBR7225VXR Physical Specifications (continued)

Description	Specification
Cisco IOS Release	12.2(33)SCA and later releases
Agency approval	Safety: UL/CSA/IEC/EN 60950-1; AS/NZS60950 EMI: FCC Class A, CSA Class A, EN60555-2, EN55022 Class A, VCCI Class 2, AS/NRZ 3548 Class A Immunity: IEC-1000-4-2, IEC-1000-4-3, IEC-1000-4-4, IEC-1000-4-5, IEC-1000-4-6, IEC-1000-4-11, IEC 1000-3-2 See the <i>Regulatory Compliance and Safety Information for Cisco uBR7200 Series Universal Broadband Routers</i> at the following URL: <a href="http://www.cisco.com/en/US/docs/cable/cmts/ubr7200/regulatory/compliance/ub72rcsi.html">http://www.cisco.com/en/US/docs/cable/cmts/ubr7200/regulatory/compliance/ub72rcsi.html</a>

1. W = watts
2. Btu = British thermal units.
3. VAC = volts alternating current.
4. AWG = American Wire Gauge.
5. cfm = cubic feet per minute.





# APPENDIX **B**

## RF Specifications

Information in the following tables is from the DOCSIS and EuroDOCSIS Radio Frequency Interface Specification, and should be considered minimum recommended performance criteria for reliable data transmission on cable networks. The full specification may be found at the CableLabs website (<http://www.cablemodem.com>), and additional Euro-DOCSIS information may be found at ComLabs website (<http://www.tcomlabs.com>).

- NCTA—“NCTA Recommended Practices for Measurements on Cable Television Systems, 2nd Edition”- National Cable Television Association, Washington DC, revised October 1993
- CableLabs1—“Two-Way Cable Television System Characterization,” Cable Television Laboratories, Inc., April 12, 1995
- CableLabs2—“Digital Transmission Characterization of Cable Television Systems,” Cable Television Laboratories, Inc., November, 1999



### Note

Raw data rate in Table B-1 and Table B-2 includes nominal data throughput plus overhead.

**Table B-1** Downstream Channel Data Rates

Modulation Format	Channel Bandwidth, MHz	Symbol Rate, Msym/sec	Raw Data Rate, Mbps	Nominal Data Rate, Mbps
QAM-64	6	5.056941	30.34	~27
QAM-256	6	5.360537	42.88	~38
QAM-64	8	6.952	41.71	~37
QAM-256	8	6.952	55.62	~50

**Table B-2** Upstream Channel Data Rates

Symbol Rate, ksym/sec	Channel Bandwidth, MHz	QPSK Raw Data Rate, Mbps	QPSK Nominal Data Rate, Mbps	QAM-16 Raw Data Rate, Mbps	QAM-16 Nominal Data Rate, Mbps
160	0.20	0.32	~0.3	0.64	~0.6
320	0.40	0.64	~0.6	1.28	~1.2
640	0.80	1.28	~1.2	2.56	~2.3

Table B-2 Upstream Channel Data Rates (continued)

Symbol Rate, ksym/sec	Channel Bandwidth, MHz	QPSK Raw Data Rate, Mbps	QPSK Nominal Data Rate, Mbps	QAM-16 Raw Data Rate, Mbps	QAM-16 Nominal Data Rate, Mbps
1280	1.60	2.56	~2.3	5.12	~4.6
2560	3.20	5.12	~4.6	10.24	~9.0

## DOCSIS 1.0 Transmission Characteristics

The following tables provide information on the assumed downstream RF channel transmission characteristics for DOCSIS 1.0.

### Downstream RF Channel Transmission Characteristics

Transmission is from the headend combiner to the cable modem input at the customer location. Measurement methods are defined in NCTA or CableLabs2 documentation.

Go to the following URL: <http://www.ncta.com/>. Search on “transmission”.

Go to the following URL: <http://www.cablelabs.com/>.

Table B-3 DOCSIS 1.0 Assumed Downstream RF Channel Transmission Characteristics

Parameter	Value
Frequency range <sup>1</sup>	Cable system normal downstream operating range is from 50 MHz to as high as 860 MHz. However, the values in this table apply only at frequencies $\geq$ 88 MHz.
RF channel spacing (design bandwidth)	6 MHz
Transit delay from headend to most distant customer	$\leq$ 0.800 msec (typically much less)
Carrier-to-noise ratio in a 6-MHz band (analog video level)	Not less than 35 dB <sup>2</sup>
Carrier-to-interference ratio for total power (discrete and broadband ingress signals)	Not less than 35 dB within the design bandwidth
Composite triple beat distortion for analog modulated carriers	Not greater than $-50$ dBc <sup>3</sup> within the design bandwidth
Composite second-order distortion for analog modulated carriers	Not greater than $-50$ dBc within the design bandwidth
Cross-modulation level	Not greater than $-40$ dBc within the design bandwidth
Amplitude ripple	0.5 dB within the design bandwidth
Group delay ripple in the spectrum occupied by the CMTS	75 ns within the design bandwidth
Micro-reflections bound for dominant echo	$-10$ dBc @ $\leq$ 0.5 microseconds $-15$ dBc @ $\leq$ 1.0 microseconds $-20$ dBc @ $\leq$ 1.5 microseconds $-30$ dBc @ $>$ 1.5 microseconds
Carrier hum modulation <sup>4</sup>	Not greater than $-26$ dBc (5%)
Burst noise	Not longer than 25 $\mu$ sec at a 10-Hz average rate
Signal level slope, 50-750 MHz	16 dB

**Table B-3** DOCSIS 1.0 Assumed Downstream RF Channel Transmission Characteristics (continued)

Parameter	Value
Seasonal and diurnal signal level variation	8 dB
Maximum analog video carrier level at the cable modem input, inclusive of above signal level variation	17 dBmV
Lowest analog video carrier level at the cable modem input, inclusive of above signal level variation	-5 dBmV

1. For measurements above the normal operating frequency band (except hum), impairments are referenced to the highest-frequency NTSC carrier level.
2. This presumes that the digital carrier is operated at analog peak carrier level. When the digital carrier is operated below the analog peak carrier level, the carrier-to-noise ratio may be less.
3. Decibels relative to carrier, a common measurement in RF engineering to specify the power of a sideband in a modulated signal relative to the carrier in decibels.
4. For hum measurements above the normal downstream operating frequency band, a continuous-wave carrier is sent at the test frequency at the same level as the highest-frequency NTSC carrier.

## Upstream RF Channel Transmission Characteristics

Transmission is from the cable modem output at the customer location to the headend. Measurement methods are defined in NCTA or CableLabs2 documentation.

**Table B-4** DOCSIS 1.0 Assumed Upstream RF Channel Transmission Characteristics

Parameter	Value
Frequency range	5 to 42 MHz edge to edge
Transit delay from the most distant cable modem to the nearest cable modem or CMTS	≤ 0.800 msec (typically much less)
Carrier-to-noise ratio	Not less than 25 dB
Carrier-to-ingress power (the sum of discrete and broadband ingress signals) ratio	Not less than 25 dB <sup>1</sup>
Carrier-to-interference (the sum of noise, distortion, common-path distortion, and cross-modulation) ratio	Not less than 25 dB
Carrier hum modulation	Not greater than -23 dBc (7%)
Burst noise	Not longer than 10 μsec at a 1-kHz average rate for most cases <sup>2, 3</sup>
Amplitude ripple	5 to 42 MHz: 0.5 dB/MHz
Group delay ripple	5 to 42 MHz: 200 ns/MHz
Micro-reflections—single echo	-10 dBc @ ≤ 0.5 microseconds -20 dBc @ ≤ 1.0 microseconds -30 dBc @ > 1.0 microseconds
Seasonal and diurnal signal level variation	Not greater than 8 dB min to max

1. Ingress avoidance or tolerance techniques may be used to ensure operation in the presence of time varying discrete ingress signals that could be as high as 0 dBc. (CableLabs1)
2. Amplitude and frequency characteristics sufficiently strong to partially or wholly mask the data carrier.
3. Impulse noise levels more prevalent at lower frequencies (<15 MHz).

# DOCSIS 1.1 Transmission Characteristics

The following tables provide information on the assumed downstream RF channel transmission characteristics for DOCSIS 1.1.

## Downstream RF Channel Transmission Characteristics

Transmission is from the headend combiner to the cable modem input at the customer location. Measurement methods are defined in NCTA or CableLabs2 documentation.

Go to the following URL: <http://www.ncta.com/>. Search on “transmission”.

Go to the following URL: <http://www.cablelabs.com/>.

**Table B-5** DOCSIS 1.1 Assumed Downstream RF Channel Transmission Characteristics

Parameter	Value
Frequency range	Cable system normal downstream operating range is from 50 MHz to as high as 860 MHz. However, the values in this table apply only at frequencies $\geq$ 88 MHz.
RF channel spacing (design bandwidth)	6 MHz
Transit delay from headend to most distant customer	$\leq$ 0.800 msec (typically much less)
Carrier-to-noise ratio in a 6-MHz band	Not less than 35 dB <sup>1</sup>
Carrier-to-composite triple beat distortion ratio	Not less than 41 dB <sup>1</sup>
Carrier-to-composite second order distortion ratio	Not less than 41 dB <sup>1</sup>
Carrier-to-cross-modulation ratio	Not less than 41 dB <sup>1</sup>
Carrier-to-any other discrete interference (ingress)	Not less than 41 dB <sup>1</sup>
Amplitude ripple	3 dB within the design bandwidth
Group delay ripple in the spectrum occupied by the CMTS	75 ns within the design bandwidth
Micro-reflections bound for dominant echo	-10 dBc @ $\leq$ 0.5 microseconds -15 dBc @ $\leq$ 1.0 microseconds -20 dBc @ $\leq$ 1.5 microseconds -30 dBc @ $>$ 1.5 microseconds
Carrier hum modulation	Not greater than -26 dBc (5%)
Burst noise	Not longer than 25 microseconds at a 10-Hz average rate
Maximum analog video carrier level at the cable modem input	17 dBmV
Maximum number of analog carriers	121

1. Measured relative to a QAM signal that is equal to the nominal video level in the plant.

## Upstream RF Channel Transmission Characteristics

Transmission is from the cable modem output at the customer location to the headend. Measurement methods are defined in NCTA or CableLabs2 documentation.

**Table B-6** *DOCSIS 1.1 Assumed Upstream RF Channel Transmission Characteristics*

Parameter	Value
Frequency range	5 to 42 MHz edge to edge
Transit delay from the most distant cable modem to the nearest cable modem or CMTS	≤ 0.800 msec (typically much less)
Carrier-to-interference plus ingress (the sum of noise, distortion, common-path distortion, and cross-modulation and the sum of discrete and broadband ingress signals, impulse noise excluded) ratio	Not less than 25 dB <sup>1</sup>
Carrier hum modulation	Not greater than -23 dBc (7%)
Burst noise	Not longer than 10 microseconds at a 1-kHz average rate for most cases <sup>2, 3</sup>
Amplitude ripple	5 to 42 MHz: 0.5 dB/MHz
Group delay ripple	5 to 42 MHz: 200 ns/MHz
Micro-reflections—single echo	-10 dBc @ ≤ 0.5 microseconds -20 dBc @ ≤ 1.0 microseconds -30 dBc @ > 1.0 microseconds
Seasonal and diurnal reverse gain (loss) variation	Not greater than 14 dB min to max

1. Ingress avoidance or tolerance techniques may be used to ensure operation in the presence of time varying discrete ingress signals that could be as high as 10 dBc. Ratios are guaranteed only within the digital carrier channels.
2. Amplitude and frequency characteristics sufficiently strong to partially or wholly mask the data carrier.
3. Impulse noise levels more prevalent at lower frequencies (<15 MHz).

## EuroDOCSIS Transmission Characteristics

The following tables provide information on the assumed RF channel transmission characteristics for EuroDOCSIS.

## Downstream RF Channel Transmission Characteristics

Transmission is from the headend combiner to the cable modem input at the customer location. Measurement methods are defined in CENELEC 50083-7 documentation.

**Table B-7** EuroDOCSIS Assumed Downstream RF Channel Transmission Characteristics for Analog TV and Sound Signals

Parameter	Value
Frequency range <sup>1</sup>	Cable system normal downstream operating range is from 47 MHz to as high as 862 MHz. However, the operating range for data communication is from 108 to 862 MHz. The use of frequencies between 108 and 136 MHz may be forbidden due to national regulation with regard to interference with aeronautical navigation frequencies.
RF channel spacing (design bandwidth)	7/8 MHz, 8 MHz channels are used for data communication
Transit delay from headend to most distant customer	≤ 0.800 msec (typically much less)
Carrier-to-noise ratio in a 8-MHz band (analog video level)	Not less than 44 dB <sup>2</sup>
Carrier-to-interference ratio for total power (discrete and broadband ingress signals)	Not less than 52 dB within the design bandwidth
Composite triple beat distortion for analog modulated carriers	PAL—Not greater than –57 dBc within the design bandwidth SECAM—Not greater than –52 dBc within the design bandwidth.
Composite second order distortion for analog modulated carriers	PAL—Not greater than –57 dBc within the design bandwidth. SECAM—Not greater than –52 dBc within the design bandwidth.
Cross-modulation level	Under consideration
Amplitude ripple	2.5 dB in 8 MHz
Group delay ripple in the spectrum occupied by the CMTS	100 ns over frequency range 0.5 to 4.43 MHz
Micro-reflections bound for dominant echo	–10 dBc @ ≤ 0.5 microseconds –15 dBc @ ≤ 1.0 microseconds –20 dBc @ ≤ 1.5 microseconds –30 dBc @ > 1.5 microseconds
Carrier hum modulation <sup>3</sup>	Not greater than –46 dBc (5%)
Burst noise	Not longer than 25 microseconds at a 10-Hz average rate
Signal level slope, 85–862 MHz	12 dB
Seasonal and diurnal signal level variation	8 dB
Maximum analog video carrier level at the system outlet, inclusive of above signal level variation	PAL: 77 dBmicroV SECAM: 74 dBmicroV
Lowest analog video carrier level at the system outlet, inclusive of above signal level variation	PAL: 60 dBmicroV SECAM: 57 dBmicroV

- For measurements shown, the normal downstream operating frequency band (except hum), impairments are referenced to the highest-frequency PAL/SECAM carrier level.
- This presumes that the digital carrier is operated at analog peak carrier level. When the digital carrier is operated below the analog peak carrier level, the carrier-to-noise ratio may be less.

- For hum measurements above the normal downstream operating frequency band, a continuous-wave carrier is sent to the test frequency at the same level as the highest-frequency PAL/SECAM carrier.

## Upstream RF Channel Transmission Characteristics

Transmission is from the cable modem output at the customer location to the headend.

**Table B-8** EuroDOCSIS Assumed Upstream RF Channel Transmission Characteristics

Parameter	Value
Frequency range	5 up to 65 MHz to edge
Transit delay from the most distant cable modem to the nearest cable modem or cable modem termination system	≤ 0.800 msec (typically much less)
Carrier-to-noise ratio in active channel	Not less than 22 dB
Carrier-to-ingress power (the sum of discrete and broadband ingress signals) ratio in active channel	Not less than 22 dB <sup>1</sup>
Carrier-to-interference (the sum of noise, distortion, common-path distortion, and cross-modulation) ratio in active channel	Not less than 22 dB
Carrier hum modulation	Not greater than -23 dBc (7%)
Burst noise	Not longer than 10 microseconds at a 1 kHz average rate for most cases <sup>2, 3</sup>
Amplitude ripple	5 to 65 MHz: 2.5 dB in 2 MHz
Group delay ripple	5 to 65 MHz: 300 ns in 2 MHz
Micro-reflections—single echo	-10 dBc @ ≤ 0.5 microseconds -20 dBc @ ≤ 1.0 microseconds -30 dBc @ > 1.0 microseconds
Seasonal and diurnal signal level variation	Not greater than 12 dB min to max

- Ingress avoidance or tolerance techniques **may** be used to ensure operation in the presence of time varying discrete ingress signals that could be as high as 0 dBc.
- Amplitude and frequency characteristics sufficiently strong to partially or wholly mask the data carrier.
- Impulse noise levels more prevalent at lower frequencies (<15 MHz).

# Electrical Input and Output

The information in [Table B-9](#) and [Table B-10](#) relates to both DOCSIS and EuroDOCSIS specifications.

**Table B-9** *Electrical Input to the Cable Modem*

Parameter	Value
Center frequency	<ul style="list-style-type: none"> <li>DOCSIS: 91 to 857 MHz <math>\pm</math>30 kHz</li> <li>EuroDOCSIS: 112 to 858 MHz <math>\pm</math>30 kHz</li> </ul>
Level range (one channel)	<ul style="list-style-type: none"> <li>DOCSIS: -15 dBmV to +15 dBmV</li> <li>EuroDOCSIS: 43 to 73 dBmicroV for QAM-64 47 to 77 dBmicroV for QAM-256</li> </ul>
Modulation type	QAM-64 and QAM-256
Symbol rate (nominal)	<ul style="list-style-type: none"> <li>DOCSIS: 5.056941 Msym/sec (QAM-64) and 5.360537 Msym/sec (QAM-256)</li> <li>EuroDOCSIS: 6.952 Msym/sec for QAM-64 and QAM-256</li> </ul>
Bandwidth	<ul style="list-style-type: none"> <li>DOCSIS: 6 MHz               <ul style="list-style-type: none"> <li>18% square root raised cosine shaping for QAM-64</li> <li>12% square root raised cosine shaping for QAM-256</li> </ul> </li> <li>EuroDOCSIS: 8 MHz               <ul style="list-style-type: none"> <li>15% square root raised cosine shaping for both QAM-64 and QAM-256</li> </ul> </li> </ul>
Total input power (40–900 MHz)	< 30 dBmV (90 dBmicroV)
Input (load) impedance	75 ohms
Input return loss	<ul style="list-style-type: none"> <li>DOCSIS: &gt; 6 dB (88–860 MHz)</li> <li>EuroDOCSIS: &gt; 6 dB (85–862 MHz)</li> </ul>
Connector	F connector per ISO-169-24 (common with the output)

**Table B-10** *Upstream Electrical Output from the Cable Modem*

Parameter	Value
Frequency	<ul style="list-style-type: none"> <li>DOCSIS: 5 to 42 MHz edge to edge</li> <li>EuroDOCSIS: 5 to 65 MHz edge to edge</li> </ul>
Level range (one channel)	<ul style="list-style-type: none"> <li>QAM-16: +8 to +55 dBmV (+68 to +115 dBmicroV)</li> <li>QPSK: +8 to +58 dBmV (+68 to +118 dBmicroV)</li> </ul>
Modulation type	QPSK and QAM-16
Symbol rate (nominal)	160 ksym/sec 320 ksym/sec 640 ksym/sec 1280 ksym/sec 2560 ksym/sec



**Table B-10** Upstream Electrical Output from the Cable Modem (continued)

Parameter	Value
Bandwidth	200 kHz 400 kHz 800 kHz 1600 kHz 3200 kHz
Output impedance	75 ohms
Output return loss	<ul style="list-style-type: none"><li>• DOCSIS: &gt;6 dB (5–42 MHz)</li><li>• EuroDOCSIS: &gt;6 dB (5–65 MHz)</li></ul>
Connector	F connector per ISO-169-24 (common with the input)





# APPENDIX **C**

## Cable Specifications

---

This appendix contains cable and cable pinout information for the Cisco uBR7225VXR universal broadband router.

- [Coaxial Cables, page C-1](#)
- [Console and Auxiliary Port Cables and Pinouts, page C-2](#)
- [Fast Ethernet Port Cables and Pinouts, page C-4](#)
- [Fiber-Optic Cables and Connectors, page C-6](#)



**Note**

---

This appendix specifies pinouts only for the pins used. Pins not listed in the tables are not connected.

---

## Coaxial Cables

The coaxial cable used to connect the Cisco uBR7200 series universal broadband routers at the headend should be very high-quality cable.

We recommend that you use a headend-grade coaxial cable or a quad-shield coaxial cable to connect the cable interface line cards to the hybrid fiber-coaxial (HFC) network. The center conductor must be straight and extend 1/8 inch (3.2 mm) beyond the end of the connector, and the connector should be securely crimped to the cable. The following headend cables are recommended:

- 59-series cable (preferred)—20 AWG (0.032 inch/0.81 mm diameter) silver plated, copper-clad, steel center conductor; bonded foil inner shield; 95 percent braid second shield; nonbonded foil third shield; 95 percent braid fourth shield.
- 59-series quad shield—20 AWG (0.032 inch/0.81 mm diameter) copper-clad steel center conductor; bonded foil inner shield; 53 percent braid second shield; nonbonded foil third shield; 34–35 percent braid fourth shield.
- 6-series quad shield—18 AWG (0.0359 inch/0.91 mm diameter) copper-clad steel center conductor; bonded foil inner shield; 60 percent braid second shield; nonbonded foil third shield; 40–42 percent braid fourth shield.



**Note**

---

Any of the three of the coaxial cables listed can be used to connect a Cisco cable interface line card to the HFC network; however, the consistent use of 59-series cable is preferred. If you connect a 59-series cable to a cable interface line card that was previously connected using 6-series cable, the difference in the center connector diameter might cause intermittent connectivity loss.

---

If you use different types of coaxial cable, the following problems can appear:

- Damage to Cisco uBR7225VXR cable interface line card connectors—Cable interface line card connectors are designed for 59-series or 6-series cable and connectors. Larger cables can damage the connectors.
- Poor return loss—High-quality cable and correct connectors help to ensure an optimal return loss of 16 dB or more.



**Caution**

Poorly shielded coaxial cable may result in undesired signal leakage (egress), interference from over-the-air signals (ingress), or crosstalk between cables in close physical proximity.

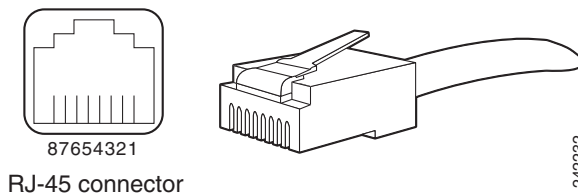
## Console and Auxiliary Port Cables and Pinouts

The router arrives with a console and auxiliary cable kit, which contains the cable and adapters you need to connect a console (an ASCII terminal or PC running terminal emulation software) or modem to the router. The console and auxiliary cable kit includes:

- RJ-45-to-RJ-45 rollover cable
- RJ-45-to-DB-9 female data terminal equipment (DTE) adapter labeled **TERMINAL**
- RJ-45-to-DB-25 male data communications equipment (DCE) adapter labeled **MODEM**

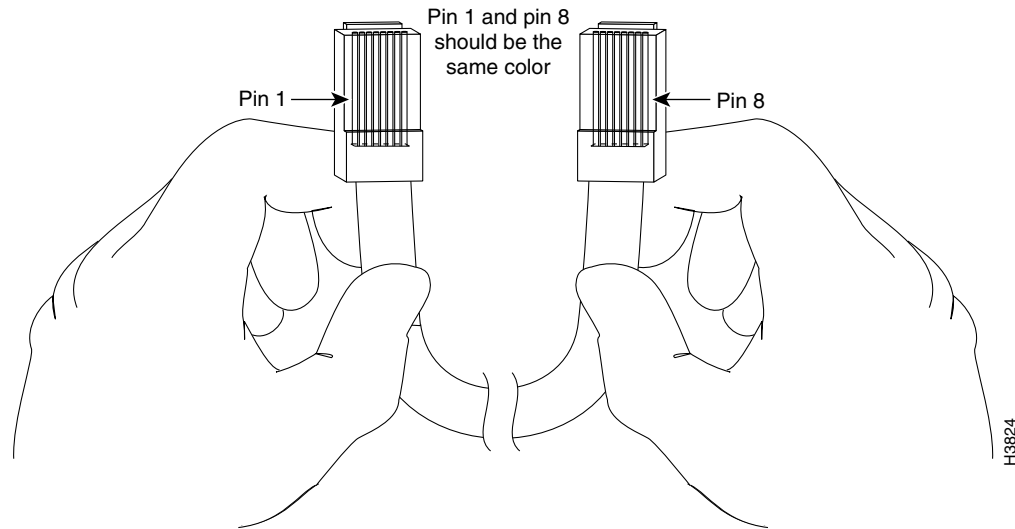
Figure C-1 shows the RJ-45 cable connector.

**Figure C-1** RJ-45 Plug and Receptacle



## Identifying an RJ-45 Rollover Cable

You can identify a rollover cable by holding the two ends of the cable next to each other with the tab at the back. The wire connected to the pin on the outside of the left hand plug should be the same color as the wire connected to the pin on the outside of the right hand plug, as shown in Figure C-2.

**Figure C-2 RJ-45 Rollover Cable Identification**

The colored wires at one connector are in the reverse order at the other connector (reverses pins 1 and 8, 2 and 7, 3 and 6, 4 and 5, 5 and 4, 6 and 3, 7 and 2, 8 and 1).

The wires of the straight-through cable are in the same sequence at both ends of the cable.

**Note**

If your cable was purchased from Cisco, pin 8 is white.

## Console Port Cables and Pinouts

Use the RJ-45-to-RJ-45 rollover cable and RJ-45-to-DB-9 female DTE adapter (labeled TERMINAL) to connect the console port to a PC running terminal emulation software. [Table C-1](#) lists the signals and pinouts for the asynchronous serial console port, the RJ-45-to-RJ-45 rollover cable, and the RJ-45-to-DB-9 female DTE adapter.

**Table C-1 Console Port Signaling and Cabling Using a DB-9 Adapter**

Console Port (DTE)	RJ-45-to-RJ-45 Rollover Cable		RJ-45-to-DB-9 Terminal Adapter	Console Device
	RJ-45 Pin	RJ-45 Pin	DB-9 Pin	
RTS	1 <sup>1</sup>	8	8	CTS
DTR	2	7	6	DSR
TxD	3	6	2	RxD
GND	4	5	5	GND
GND	5	4	5	GND
RxD	6	3	3	TxD
DSR	7	2	4	DTR
CTS	8 <sup>1</sup>	1	7	RTS

1. Pin 1 is connected internally to pin 8.

## Auxiliary Port Cables and Pinouts

Use the RJ-45-to-RJ-45 rollover cable and RJ-45-to-DB-25 male DCE adapter (labeled MODEM) to connect the auxiliary port to a modem. Table C-2 lists the signals and pinouts for the asynchronous serial auxiliary port, the RJ-45-to-RJ-45 rollover cable, and the RJ-45-to-DB-25 male DCE adapter (labeled MODEM).

**Table C-2** Auxiliary Port Signaling and Cabling Using a DB-25 Adapter

AUX Port (DTE)	RJ-45-to-RJ-45 Rollover Cable		RJ-45-to-DB-25 Modem Adapter	Modem (DCE)
	RJ-45 Pin	RJ-45 Pin	DB-25 Pin	
Signal				Signal
RTS	1	8	4	RTS
DTR	2	7	20	DTR
TxD	3	6	3	TxD
GND	4	5	7	GND
GND	5	4	7	GND
RxD	6	3	2	RxD
DSR	7	2	8	DCD
CTS	8	1	5	CTS

## Fast Ethernet Port Cables and Pinouts

The 10Base-T/100Base-TX Fast Ethernet ports support IEEE 802.3 and IEEE 802.3u specifications for 10-Mbps and 100-Mbps transmission over unshielded twisted-pair (UTP) cables. Each Fast Ethernet port on the NPE has an RJ-45 connector to attach to Category 3 or Category 5 UTP cables.

- Use a Category 3 UTP crossover cable when connecting 10Base-T port to a hub.
- Use a Category 3 UTP straight-through cable when connecting to a PC or other Ethernet device.
- Use a Category 5 UTP crossover cable when connecting 100Base-TX to a hub.
- Use a Category 5 UTP straight-through cable when connecting to a PC or other Ethernet device.

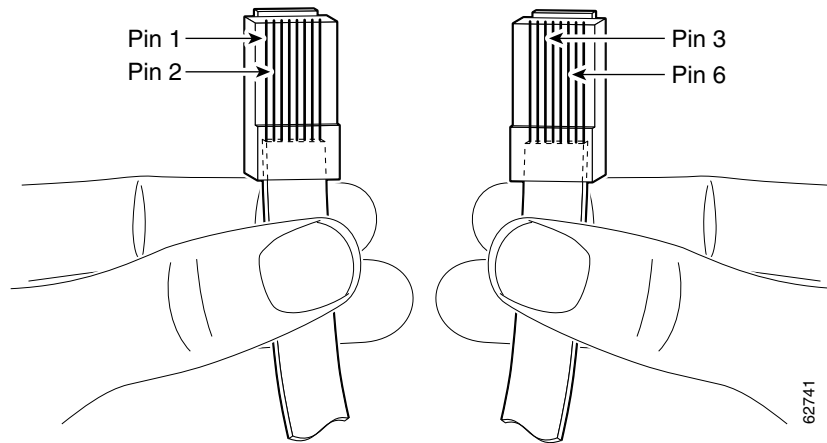


### Note

Cisco does not supply Category 3 or Category 5 UTP RJ-45 cables; these cables are available commercially.

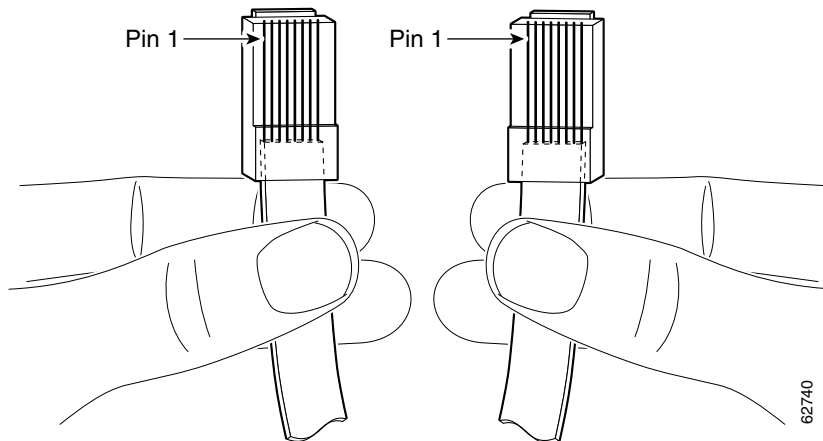
## Identifying an RJ-45 Crossover Cable

You can identify a crossover cable by comparing the two modular ends of the cable. Hold the cables side-by-side with the tab at the back. The first (far left) colored wire (pin 1) at one end of the cable is the third colored wire (pin 3) at the other end of the cable. The second colored wire (pin 2) at one end of the cable is the sixth colored wire (pin 6) at the other end of the cable. Pin 1 wire is white. See Figure C-3.

**Figure C-3 RJ-45 Crossover Cable Identification**

## Identifying an RJ-45 Straight-Through Cable

You can identify a straight-through cable by comparing the two modular ends of the cable. Hold the cables side-by-side with the tab at the back. The straight-through cable's wires are in the same sequence at both ends of the cable. See [Figure C-4](#).

**Figure C-4 RJ-45 Straight-Through Cable Identification****Note**

If your cable was purchased from Cisco, pin 1 is white. Pins 4, 5, 7, and 8 are not connected.

[Table C-3](#) lists the pinouts for the two Fast Ethernet ports.

**Table C-3 10BASE-T RJ-45 Connector Pinouts**

RJ-45 Pin	Description	RJ-45 Pin	Description
1	Tx+	3	Rx+
2	Tx-	6	Rx-

# Fiber-Optic Cables and Connectors



**Warning**

Because invisible radiation may be emitted from the aperture of the port when no fiber cable is connected, avoid exposure to radiation and do not stare into open apertures. Statement 1056

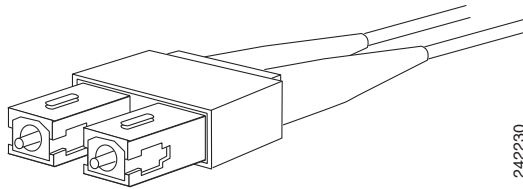


**Warning**

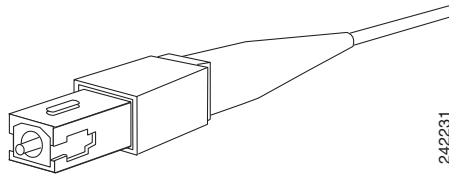
**Class 1 laser product.** Statement 1008

Use a single-mode or multimode fiber-optic interface cable to connect your Cisco uBR7225VXR router to another router or switch. In general, multimode cables are gray or orange, and single-mode cables are yellow. For Ethernet and multimode fiber-optic connections, use one duplex SC-type connector (Figure C-5) or two simplex SC-type connectors. (See Figure C-6.)

**Figure C-5 Duplex SC Cable Connector**

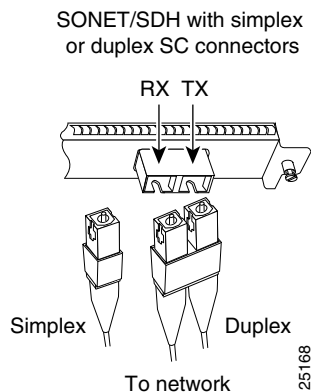


**Figure C-6 Simplex SC Cable Connector**



Attach either one duplex fiber cable or two simplex fiber cables between the digital pulse terminator (DPT) port adapter and the device to which the DPT port adapter is connected. Observe the receive (RX) and transmit (TX) cable relationship shown in Figure C-7.

**Figure C-7 Attaching Simplex or Duplex Fiber-Optic Cables**







## Industry-Standard Wiring Plans

---

### About Wiring Standards

In a traditional cable headend, a large number of wires connect the various components of the headend system. To organize the many wires, some cable operators use color-coding on the wire jackets based on signal type, and channel number or program content.

With the advancement of two-way Data-over-Cable services and fiber-optic nodes on the network, the cable headend wiring has become even more complex:

- A single upstream cable can now carry signals from multiple services and from many combinations of fiber-optic nodes—not just one.
- Each fiber-optic node has different content provided by the digital data services at the same frequency or channel locations—not separate channels.
- For proper testing of the network, more downstream test points are required. In addition, upstream test points of calibrated signal amplitude are becoming essential.

**Note**

---

Several third-party companies have available commercially-manufactured equipment that includes fixed or modular splitters, combiners, and test points for headend RF management.

---

Many coaxial cable manufacturers offer various jacket color options for headend-grade coaxial cable. To date, there are no official standards for headend coaxial cable color schemes, although individual cable companies and multiple system operators (MSOs) have in some instances implemented their own.

The telephone industry has developed standardized color schemes for telephony wiring applications. Some of these are included here for the benefit of cable operators that have or are deploying voice services on their cable networks. This appendix also includes standardized color codes for optical fiber.

## TIA/EIA Standards Information

A number of Electronic Industries Alliance (EIA) and Telecommunications Industry Association (TIA) standards are applicable to wiring.

Following is a list of applicable standards:

- TIA/EIA Telecommunications Building Wiring Standards Collection
- TIA/EIA-568A—Commercial Building Telecommunications Cabling Standard
- TIA/EIA-569A—Commercial Building Standard for Telecommunications Pathways and Spaces
- TIA/EIA-570A—Residential Telecommunications Cabling Standard
- TIA/EIA-598—Optical Fiber Cable Color Coding
- TIA/EIA-606—The Administration Standard for the Telecommunications Infrastructure of Commercial Buildings
- TIA/EIA-607—Commercial Building Grounding and Bonding Requirements for Telecommunications
- TIA/EIA TSB 72—Centralized Optical Fiber Cabling Guidelines
- TIA/EIA TSB 75—Additional Horizontal Cabling Practices for Open Offices
- TIA/EIA TSB 95—Additional Performance Guidelines for 4-Pair 100 OHM Category 5 Cabling

In addition, the following relevant standards are available from Global Engineering Documents:

- FIBS PUB 175—Federal Building Standard for Telecommunication Pathways and Spaces
- FIBS PUB 176—Residential and Light Commercial Telecommunications Wiring Standard

## Optical Fiber Color Codes

The most common color code for optical fiber is based on the ten colors that are used for plastic insulated conductor copper cables. Two other colors have been added to bring the optical fiber color code to twelve. These colors are now standardized under TIE/EIA-598—Optical Fiber Cable Color Coding.

The coloring specified in TIA/EIA-598 is used to identify individual optical fibers when the colors are applied to the surface of the coated fiber or included directly in the fiber's secondary coating. See [Table D-1](#). Buffered fibers have colored plastic buffering jackets. The standard colors also may be used to identify units (groups of fibers or loose tubes) or ribbons on a given cable. As well, units and ribbons may be identified with printed markings.

**Table D-1** TIA/EIA-598 Color Code

Position	Color
1	Blue
2	Orange
3	Green
4	Brown
5	Slate
6	White
7	Red

**Table D-1** TIA/EIA-598 Color Code (continued)

Position	Color
8	Black
9	Yellow
10	Violet
11	Rose
12	Aqua

## Telephone Wire Color Codes

To help simplify wire management, AT&T has devised a uniform scheme for dealing with large numbers of wires for the telephone industry. The scheme uses two color codes—one for large numbers of wires organized in pairs—and the other for smaller numbers of wires that can also be organized in pairs. We recommend that you try to implement this wiring scheme whenever possible.

For large numbers of wires, each pair is assigned a two-color code. The colors are selected from two groups of five, resulting in what is called a *binder-group* of 25 pairs. The colors used for a group are white, red, black, yellow, and violet. The colors used for “pair within a group” are blue, orange, green, brown, and slate.

Each pair must have a unique color combination. One wire within each pair has a solid background of its group color and stripes of the “pair within a group” color; the second wire has the colors reversed. [Table D-2](#) lists the sequences. Note that red-brown and red-orange wires may be easily confused.

**Table D-2** Telephone Industry 25-Pair Color Code and Pin Numbers

Pair Number	Wire Number	Solid Color	Stripe Color	Pin Number
1	1	White	Blue	26
1	2	Blue	White	1
2	1	White	Orange	27
2	2	Orange	White	2
3	1	White	Green	28
3	2	Green	White	3
4	1	White	Brown	29
4	2	Brown	White	4
5	1	White	Slate	30
5	2	Slate	White	5
6	1	Red	Blue	31
6	2	Blue	Red	6
7	1	Red	Orange	32
7	2	Orange	Red	7
8	1	Red	Green	33
8	2	Green	Red	8

**Table D-2 Telephone Industry 25-Pair Color Code and Pin Numbers (continued)**

Pair Number	Wire Number	Solid Color	Stripe Color	Pin Number
9	1	Red	Brown	34
9	2	Brown	Red	9
10	1	Red	Slate	35
10	2	Slate	Red	10
11	1	Black	Blue	36
11	2	Blue	Black	11
12	1	Black	Orange	37
12	2	Orange	Black	12
13	1	Black	Green	38
13	2	Green	Black	13
14	1	Black	Brown	39
14	2	Brown	Black	14
15	1	Black	Slate	40
15	2	Slate	Black	15
16	1	Yellow	Blue	41
16	2	Blue	Yellow	16
17	1	Yellow	Orange	42
17	2	Orange	Yellow	17
18	1	Yellow	Green	43
18	2	Green	Yellow	18
19	1	Yellow	Brown	44
19	2	Brown	Yellow	19
20	1	Yellow	Slate	45
20	2	Slate	Yellow	20
21	1	Violet	Blue	46
21	2	Blue	Violet	21
22	1	Violet	Orange	47
22	2	Orange	Violet	22
23	1	Violet	Green	48
23	2	Green	Violet	23
24	1	Violet	Brown	49
24	2	Brown	Violet	24
25	1	Violet	Slate	50
25	2	Slate	Violet	25

Cables with more than 25 pairs of wires are constructed from 25-pair groups. Very large cables have other variations generally not encountered inside terminal wire plants.

For small wiring groups, such as wires for an individual telephone station or terminal, you may use a second color-code scheme. Table D-2 lists this color code and the usual correspondence with the paired-wire color code. The alternate color code is included, because sometimes the station wire uses the first three pairs of the standard color code (white-blue, blue-white, and so on), while other times it uses the six alternate color wires.

**Table D-3** *Alternate Color Code Scheme for Smaller Numbers of Wires*

Pair Number	Wire Number	Solid Color	Stripe Color	Alternate Color	Pin Number
1	1	White	Blue	Green	4
1	2	Blue	White	Red	3
2	1	White	Orange	Black	2
2	2	Orange	White	Yellow	5
3	1	White	Green	White	1
3	2	Green	White	Blue	6





## Frequency Allocation Tables

---

This appendix provides information on broadcast and cable television NTSC and PAL/SECAM standards and frequencies used around the world.

There are three standards for transmitting video. They are defined by the method of encoding color onto a monochrome signal. The methods are defined as:

- NTSC—National Television System Committee

NTSC is the current standard used for analog television in the United States and elsewhere. NTSC supports color television transmission in a 6-MHz channel bandwidth and has 525 interlaced scan lines. Two fields are interlaced to make one frame with a frame rate of 29.97 frames per second and a field rate of 59.94 fields per second. A fraction (approximately 8 percent) of the available bandwidth is used for signal synchronization between the transmitter and the receiver, giving an effective resolution of 640 x 480. The aspect ratio, or ratio of picture width to picture height, is 4:3.

- PAL—Phase Alternating Line

PAL is a composite color system similar to NTSC. In PAL, however, the color difference signals alternate phase at the horizontal line rate. PAL video consists of a 625-line frame, a frame rate of 25 Hz, and a field rate of 50 Hz. As with NTSC, approximately 8 percent of the available bandwidth is used for synchronization yielding an effective resolution of 768 x 576. The aspect ratio is 4:3. The PAL standard and its variants are used primarily in Europe, Asia, Africa, Australia, Brazil, and Argentina.

- SECAM—SEquential Couleur Avec Memoire

SECAM is a color television broadcasting system using 625 picture lines and a 50-hertz (Hz) field rate, in which the two color-difference signals are transmitted sequentially instead of simultaneously.

NTSC information is covered in [Table E-4 on page E-3](#) and [Table E-5 on page E-8](#). General PAL/SECAM information is covered in [Table E-6 on page E-10](#). Use the information in [Table E-1](#), [Table E-2](#), and [Table E-3 on page E-2](#) to compare analog television standards used around the world.

Check these websites for more information:

<http://www.blondertongue.com>

<http://www.geo-orbit.org>

<http://www.acterna.com>

<http://developer.apple.com>

<http://www.c-cor.net>

<http://atxnetworks.com>

<http://www.alkenmrs.com>

# Standards Comparisons

The following tables (Table E-1, Table E-2, and Table E-3) include data from Recommendation ITU-R BT.470.6, Conventional Television Systems (1998) and provide a comparison of the different standards.

**Table E-1 Analog Television System Baseband Video Parameters**

	<b>M</b>	<b>N</b>	<b>B, B1, D1, G</b>	<b>H</b>	<b>I</b>	<b>D, K</b>	<b>K1</b>	<b>L</b>
<b>Lines per frame</b>	525	625	625	625	625	625	625	625
<b>Field rate (Hz)</b>	Monochrome: 60 Color: 59.94	50	50	50	50	50	50	50
<b>Horizontal rate (Hz)</b>	Monochrome: 15,750 Color: 15,734.264	15,625	15,625	15,625	15,625	15,625	15,625	15,625
<b>Video bandwidth (Mhz)</b>	4.2	4.2	5	5	5.5	6	6	6

**Table E-2 Analog Television Chrominance Sub Carrier Frequencies**

	<b>M/NTSC</b>	<b>M/PAL</b>	<b>B, B1, D, D1, G, H, K, N/PAL</b>	<b>I/PAL</b>	<b>N/PAL<sup>1</sup></b>	<b>B, D, G, H, K, K1, L/SECAM</b>
<b>Chrominance sub carrier frequency (Hz)</b>	3,579,545 $\pm 10$	3,575,611.49 $\pm 10$	4,433,618.75 $\pm 5$	4,433,618.75 $\pm 1$	3,582,056.25 $\pm 5$	$f_{OR} = 4,406,250$ $\pm 2,000$  $f_{OB} = 4,250,000$ $\pm 2,000$

1. This value applies to the combination N/PAL used in Argentina.

**Table E-3 Analog Television System RF Parameters**

	<b>M</b>	<b>N</b>	<b>B, B1, G</b>	<b>H</b>	<b>I</b>	<b>D, D1, K</b>	<b>K1</b>	<b>L</b>
<b>Channel bandwidth at RF (MHz)</b>	6	6	B=7 B1, G=8	8	8	8	8	8
<b>Frequency separation between visual and aural carrier (MHz)</b>	4.5	4.5	5.5	5.5	5.9996	6.5	6.5	6.5



# NTSC Cable Television Channels and Relative Frequencies

Table E-4 provides information on the NTSC frequency map for standard 6-MHz channels in North, Central, and South America, as well as parts of Asia. Table E-5 on page E-8 lists NTSC assignments for Japan.

**Table E-4** NCTA Cable Television Channels and Relative Frequencies

Channel No. <sup>1</sup>	Channel No., EIA	Bandwidth (MHz)	Visual Carrier (MHz)	Center Freq.	Aural Carrier (MHz)	Incrementally Related Carrier		Harmonically Related Carrier	
						Visual	Aural	Visual	Aural
T-7	none	5.75-11.75	7	8.75	11.5	N/A	N/A	N/A	N/A
T-8	none	11.75-17.75	13	14.75	17.5	N/A	N/A	N/A	N/A
T-9	none	17.75-23.75	19	10.75	23.5	N/A	N/A	N/A	N/A
T-10	none	23.75-29.75	25	26.75	29.5	N/A	N/A	N/A	N/A
T-11	none	29.75-35.75	31	32.75	35.5	N/A	N/A	N/A	N/A
T-12	none	35.75-41.75	37	38.75	41.5	N/A	N/A	N/A	N/A
T-13	none	41.75-47.75	43	44.75	47.5	N/A	N/A	N/A	N/A
TV-IF	none	40.0-46.0	45.75	44.0	41.25	N/A	N/A	N/A	N/A
2	2	54.0-60.0	55.25	57.0	59.75	55.2625	59.7625	54.0027	58.5027
3	3	60.0-66.0	61.25	63.0	65.75	61.2625	65.7625	60.0030	64.5030
4	4	66.0-72.0	67.25	69.0	71.75	67.2625	71.7625	66.0033	70.5030
5	5	76.0-82.0	77.25	79.0	81.75	79.2625	83.7625	78.0039	82.5039
6	6	82.0-88.0	83.25	85.0	87.75	85.2625	89.7625	84.0042	88.5042
	FM	88.0-108.0							
A-5	95	90.0-96.0	91.25	93.0	95.75	91.2625	95.7625	90.0045	94.5045
A-4	96	96.0-102.0	97.25	99.0	101.75	97.2625	101.7625	96.0048	100.5048
A-3	97	102.0-108.0	103.25	105.0	107.75	103.2625	107.7625	102.0051	106.5051
A-2	98 <sup>2</sup>	108.0-114.0	109.25	111.0	113.75	109.2750	113.7750	Cannot lock to comb	
A-1	99 <sup>2</sup>	114.0-120.0	115.25	117.0	119.75	115.2750	119.7750	ref: Refer to FCC regulations	
A	14 <sup>2</sup>	120.0-126.0	121.25	123.0	125.75	121.2625	125.7625	120.0060	124.5060
B	15 <sup>2</sup>	126.0-132.0	127.25	129.0	131.75	127.2625	131.7625	126.0063	130.5063
C	16 <sup>2</sup>	132.0-138.0	133.25	135.0	137.75	133.2625	137.7625	132.0066	136.5066
D	17	138.0-144.0	139.25	141.0	143.75	139.2625	143.7625	138.0069	142.5069
E	18	144.0-150.0	145.25	147.0	149.75	145.2625	149.7625	144.0072	148.5072
F	19	150.0-156.0	151.25	153.0	155.75	151.2625	155.7625	150.0075	154.5075
G	20	156.0-162.0	157.25	159.0	161.75	157.2625	161.7625	156.0078	160.5078
H	21	162.0-168.0	163.25	165.0	167.75	163.2625	167.7625	162.0081	166.5081
I	22	168.0-174.0	169.25	171.0	173.75	169.2625	173.7625	168.0084	172.5084
7	7	174.0-180.0	175.25	177.0	179.75	175.2625	179.7625	174.0087	178.5087

Table E-4 NCTA Cable Television Channels and Relative Frequencies (continued)

Channel No. <sup>1</sup>	Channel No., EIA	Bandwidth (MHz)	Visual Carrier (MHz)	Center Freq.	Aural Carrier (MHz)	Incrementally Related Carrier		Harmonically Related Carrier	
						Visual	Aural	Visual	Aural
8	8	180.0-186.0	181.25	183.0	185.75	181.2625	185.7625	180.0090	184.5090
9	9	186.0-192.0	187.25	189.0	191.75	187.2625	191.7625	186.0093	190.5093
10	10	192.0-198.0	193.25	195.0	197.75	193.2625	197.7625	192.0096	196.5096
11	11	198.0-204.0	199.25	201.0	203.75	199.2625	203.7625	198.0099	202.5099
12	12	204.0-210.0	205.25	207.0	209.75	205.2625	209.7625	204.0102	208.5102
13	13	210.0-216.0	211.25	213.0	215.75	211.2625	215.7625	210.0105	214.5105
J	23	216.0-222.0	217.25	219.0	221.75	217.2625	211.7625	216.0108	220.5108
K	24 <sup>2</sup>	222.0-228.0	223.25	225.0	227.75	223.2625	227.7625	222.0111	226.5111
L	25 <sup>2</sup>	228.0-234.0	229.25	231.0	233.75	229.2625	233.7625	228.0114	232.5114
M	26 <sup>2</sup>	234.0-240.0	235.25	237.0	239.75	235.2625	239.7625	234.0117	238.5117
N	27 <sup>2</sup>	240.0-246.0	241.25	243.0	245.75	241.2625	245.7625	240.0120	244.5120
O	28 <sup>2</sup>	246.0-252.0	247.25	249.0	251.75	247.2625	251.7625	246.0123	250.5123
P	29 <sup>2</sup>	252.0-258.0	253.25	255.0	257.75	253.2625	257.7625	252.0126	256.5126
Q	30 <sup>2</sup>	258.0-264.0	259.25	261.0	263.75	259.2625	263.7625	258.0129	262.5129
R	31 <sup>2</sup>	264.0-270.0	265.25	267.0	269.75	265.2625	269.7625	264.0132	268.5132
S	32 <sup>2</sup>	270.0-276.0	271.25	273.0	275.75	271.2625	275.7625	270.0135	274.5135
T	33 <sup>2</sup>	276.0-282.0	277.25	279.0	281.75	277.2625	281.7625	276.0138	270.5138
U	34 <sup>2</sup>	282.0-288.0	283.25	285.0	287.75	283.2625	287.7625	282.0141	286.5141
V	35 <sup>2</sup>	288.0-294.0	289.25	291.0	293.75	289.2625	293.7625	288.0144	292.5144
W	36 <sup>2</sup>	294.0-300.0	295.25	297.0	299.75	295.2625	299.7625	294.0147	298.5147
AA	37 <sup>2</sup>	300.0-306.0	301.25	303.0	305.75	301.2625	305.7625	300.0150	304.5150
BB	38 <sup>2</sup>	306.0-312.0	307.25	309.0	311.75	307.2625	311.7625	306.0153	310.5153
CC	39 <sup>2</sup>	312.0-318.0	313.25	315.0	317.75	313.2625	317.7625	312.0156	316.5156
DD	40 <sup>2</sup>	318.0-324.0	319.25	321.0	323.75	319.2625	323.7625	318.0159	322.5159
EE	41 <sup>2</sup>	324.0-330.0	325.25	327.0	329.75	325.2625	329.7625	324.0162	328.5162
FF	42 <sup>2</sup>	330.0-336.0	331.25	333.0	335.75	331.2625	335.7625	330.0165	334.5165
GG	43 <sup>2</sup>	336.0-342.0	337.25	339.0	341.75	337.2625	341.7625	336.0168	340.5168
HH	44 <sup>2</sup>	342.0-348.0	343.25	345.0	347.75	343.2625	347.7625	342.0171	346.5171
II	45 <sup>2</sup>	348.0-354.0	349.25	351.0	353.75	349.2625	353.7625	348.0174	352.5174
JJ	46 <sup>2</sup>	354.0-360.0	355.25	357.0	359.75	355.2625	359.7625	354.0177	358.5177
KK	47 <sup>2</sup>	360.0-366.0	361.25	363.0	365.75	361.2625	365.7625	360.0180	364.5180
LL	48 <sup>2</sup>	366.0-372.0	367.25	369.0	371.75	367.2625	371.7625	366.0183	370.5183
MM	49 <sup>2</sup>	372.0-378.0	373.25	375.0	377.75	373.2625	377.7625	372.0186	376.5186
NN	50 <sup>2</sup>	378.0-384.0	379.25	381.0	383.75	379.2625	383.7625	378.0189	382.5189
OO	51 <sup>2</sup>	384.0-390.0	385.25	387.0	389.75	385.2625	389.7625	384.0192	388.5192

Table E-4 NCTA Cable Television Channels and Relative Frequencies (continued)

Channel No. <sup>1</sup>	Channel No., EIA	Bandwidth (MHz)	Visual Carrier (MHz)	Center Freq.	Aural Carrier (MHz)	Incrementally Related Carrier		Harmonically Related Carrier	
						Visual	Aural	Visual	Aural
PP	52 <sup>2</sup>	390.0-396.0	391.25	393.0	395.75	391.2625	395.7625	390.0195	394.5195
QQ	53 <sup>2</sup>	396.0-402.0	397.25	399.0	401.75	397.2625	401.7625	396.0198	400.5198
RR	54	402.0-408.0	403.25	405.0	407.75	403.2625	407.7625	402.0201	406.5201
SS	55	408.0-414.0	409.25	411.0	413.75	409.2625	413.7625	408.0204	412.5204
TT	56	414.0-420.0	415.25	417.0	419.75	415.2625	419.7625	414.0207	418.5207
UU	57	420.0-426.0	421.25	423.0	425.75	421.2625	425.7625	420.0210	424.5210
VV	58	426.0-432.0	427.25	429.0	431.75	427.2625	431.7625	426.0213	430.5213
WW	59	432.0-438.0	433.25	435.0	437.75	433.2625	437.7625	432.0216	436.5216
XX	60	438.0-444.0	439.25	441.0	443.75	439.2625	443.7625	438.0219	442.5219
YY	61	444.0-450.0	445.25	447.0	449.75	445.2625	449.7625	444.0222	448.5222
ZZ	62	450.0-456.0	451.25	453.0	455.75	451.2625	455.7625	450.0225	454.5225
	63	456.0-462.0	457.25	459.0	461.75	457.2625	461.7625	456.0228	460.5228
	64	462.0-468.0	463.25	465.0	467.75	463.2625	467.7625	462.0231	466.5231
	65	468.0-474.0	469.25	471.0	473.75	469.2625	473.7625	468.0234	472.5234
	66	474.0-480.0	475.25	477.0	479.75	475.2625	479.7625	474.0237	478.5237
	67	480.0-486.0	481.25	483.0	485.75	481.2625	485.7625	480.0240	484.5240
	68	486.0-492.0	487.25	489.0	491.75	487.2625	491.7625	486.0243	490.5243
	69	492.0-498.0	493.25	495.0	497.75	493.2625	497.7625	492.0246	496.5246
	70	498.0-504.0	499.25	501.0	503.75	499.2625	503.7625	498.0249	502.5249
	71	504.0-510.0	505.25	507.0	509.75	505.2625	509.7625	504.0252	508.5252
	72	510.0-516.0	511.25	513.0	515.75	511.2625	515.7625	510.0255	514.5255
	73	516.0-522.0	517.25	519.0	521.75	517.2625	521.7625	516.0258	520.5258
	74	522.0-528.0	523.25	525.0	527.75	523.2625	527.7625	522.0261	526.5261
	75	528.0-534.0	529.25	531.0	533.75	529.2625	533.7625	528.0264	532.5264
	76	534.0-540.0	535.25	537.0	539.75	535.2625	539.7625	534.0267	538.5267
	77	540.0-546.0	541.25	543.0	545.75	541.2625	545.7625	540.0270	544.5270
	78	546.0-552.0	547.25	549.0	551.75	547.2625	551.7625	556.0273	550.5273
	79	552.0-558.0	553.25	555.0	557.75	553.2625	557.7625	552.0276	556.5276
	80	558.0-564.0	559.25	561.0	563.75	559.2625	563.7625	558.0279	562.5279
	81	564.0-570.0	565.25	567.0	569.75	565.2625	569.7625	564.0282	568.5282
	82	570.0-576.0	571.25	573.0	575.75	571.2625	575.7625	570.0285	574.5285
	83	576.0-582.0	577.25	579.0	581.75	577.2625	581.7625	576.0288	580.5288
	84	582.0-588.0	583.25	585.0	587.75	583.2625	587.7625	582.0291	586.5291
	85	588.0-594.0	589.25	591.0	593.75	589.2625	593.7625	588.0294	592.5294
	86	594.0-600.0	595.25	597.0	599.75	595.2625	599.7625	594.0297	598.5297

Table E-4 NCTA Cable Television Channels and Relative Frequencies (continued)

Channel No. <sup>1</sup>	Channel No., EIA	Bandwidth (MHz)	Visual Carrier (MHz)	Center Freq.	Aural Carrier (MHz)	Incrementally Related Carrier		Harmonically Related Carrier	
						Visual	Aural	Visual	Aural
	87	600.0-606.0	601.25	603.0	605.75	601.2625	605.7625	600.0300	604.5300
	88	606.0-612.0	607.25	609.0	611.75	607.2625	611.7625	606.0303	610.5303
	89	612.0-618.0	613.25	615.0	617.75	613.2625	617.7625	612.0306	616.5306
	90	618.0-624.0	619.25	621.0	623.75	619.2625	623.7625	618.0309	622.5309
	91	624.0-630.0	625.25	627.0	629.75	625.2625	629.7625	624.0312	628.5312
	92	630.0-636.0	631.25	633.0	635.75	631.2625	635.7625	630.0315	634.5315
	93	636.0-642.0	637.25	639.0	641.75	637.2625	641.7625	636.0318	640.5318
	94	642.0-648.0	643.25	645.0	647.75	643.2625	647.7625	642.0321	646.5321
	100	648.0-654.0	649.25	651.0	653.75	649.2625	653.7625	648.0324	652.5324
	101	654.0-660.0	655.25	657.0	659.75	655.2625	659.7625	654.0327	658.5327
	102	660.0-666.0	661.25	663.0	665.75	661.2625	665.7625	660.0330	664.5330
	103	666.0-672.0	667.25	669.0	671.75	667.2625	671.7625	666.0333	670.5333
	104	672.0-678.0	673.25	675.0	677.75	673.2625	677.7625	672.0336	676.5336
	105	678.0-684.0	679.25	681.0	683.75	679.2625	683.7625	678.0339	682.5339
	106	684.0-690.0	685.25	687.0	689.75	685.2625	689.7625	684.0342	688.5342
	107	690.0-696.0	691.25	693.0	695.75	691.2625	695.7625	690.0345	694.5345
	108	696.0-702.0	697.25	699.0	701.75	697.2625	701.7625	696.0348	700.5348
	109	702.0-708.0	703.25	705.0	707.75	703.2625	707.7625	702.0351	706.5351
	110	708.0-714.0	709.25	711.0	713.75	709.2625	713.7625	708.0354	712.5354
	111	714.0-720.0	715.25	717.0	719.75	715.2625	719.7625	714.0357	718.5357
	112	720.0-726.0	721.25	723.0	725.75	721.2625	725.7625	720.0360	724.5360
	113	726.0-732.0	727.25	729.0	731.75	727.2625	731.7625	726.0363	730.5363
	114	732.0-738.0	733.25	735.0	737.75	733.2625	737.7625	732.0366	736.5366
	115	738.0-744.0	739.25	741.0	743.75	739.2625	743.7625	738.0369	742.5369
	116	744.0-750.0	745.25	747.0	749.75	745.2625	749.7625	744.0372	748.5372
	117	750.0-756.0	751.25	753.0	755.75	751.2625	755.7625	750.0375	754.5375
	118	756.0-762.0	757.25	759.0	761.75	757.2625	761.7625	756.0378	760.5378
	119	762.0-768.0	763.25	765.0	767.75	763.2625	767.7625	762.0381	766.5381
	120	768.0-774.0	769.25	771.0	773.75	769.2625	773.7625	768.0384	772.5384
	121	774.0-780.0	775.25	777.0	779.75	775.2625	779.7625	774.0387	778.5387
	122	780.0-786.0	781.25	783.0	785.75	781.2625	785.7625	780.0390	784.5390
	123	786.0-792.0	787.25	789.0	791.75	787.2625	791.7625	786.0393	790.5393
	124	792.0-798.0	793.25	795.0	797.75	793.2625	797.7625	792.0396	796.5396
	125	798.0-804.0	799.25	801.0	803.75	799.2625	803.7625	798.0399	802.5399
	126	804.0-810.0	805.25	807.0	809.75	805.2625	809.7625	804.0402	808.5402

Table E-4 NCTA Cable Television Channels and Relative Frequencies (continued)

Channel No. <sup>1</sup>	Channel No., EIA	Bandwidth (MHz)	Visual Carrier (MHz)	Center Freq.	Aural Carrier (MHz)	Incrementally Related Carrier		Harmonically Related Carrier	
						Visual	Aural	Visual	Aural
	127	810.0-816.0	811.25	813.0	815.75	811.2625	815.7625	810.0405	814.5405
	128	816.0-822.0	817.25	819.0	821.75	817.2625	821.7625	816.0408	820.5408
	129	822.0-828.0	823.25	825.0	827.75	823.2625	827.7625	822.0411	826.5411
	130	828.0-834.0	829.25	831.0	833.75	829.2625	833.7625	828.0414	832.5414
	131	834.0-840.0	835.25	837.0	839.75	835.2625	839.7625	834.0417	838.5417
	132	840.0-846.0	841.25	843.0	845.75	841.2625	845.7625	840.0420	844.5420
	133	846.0-852.0	847.25	849.0	851.75	847.2625	851.7625	846.0423	850.5423
	134	852.0-858.0	853.25	855.0	857.75	853.2625	857.7625	852.0426	856.5426
	135	858.0-864.0	859.25	861.0	863.75	859.2625	863.7625	858.0429	862.5429
	136	864.0-870.0	865.25	867.0	869.75	865.2625	869.7625	864.0432	868.5432
	137	870.0-876.0	871.25	873.0	875.75	871.2625	875.7625	870.0435	874.5435
	138	876.0-882.0	877.25	879.0	881.75	877.2625	881.7625	876.0438	880.5438
	139	882.0-888.0	883.25	885.0	887.75	883.2625	887.7625	882.0441	886.5441
	140	888.0-894.0	889.25	891.0	893.75	889.2625	893.7625	888.0444	892.5444
	141	894.0-900.0	895.25	897.0	899.75	895.2625	899.7625	894.0447	898.5447
	142	900.0-906.0	901.25	903.0	905.75	901.2625	905.7625	900.0450	904.5450
	143	906.0-912.0	907.25	909.0	911.75	907.2625	911.7625	906.0453	910.5453
	144	912.0-918.0	913.25	915.0	917.75	913.2625	917.7625	912.0456	916.5456
	145	918.0-924.0	919.25	921.0	923.75	919.2625	923.7625	918.0459	922.5459
	146	924.0-930.0	925.25	927.0	929.75	925.2625	929.7625	924.0462	928.5462
	147	930.0-936.0	931.25	933.0	935.75	931.2625	935.7625	930.0465	934.5465
	148	936.0-942.0	937.25	939.0	941.75	937.2625	941.7625	936.0468	940.5468
	149	942.0-948.0	943.25	945.0	947.75	943.2625	947.7625	942.0471	946.5471
	150	948.0-954.0	949.25	951.0	953.75	949.2625	953.7625	948.0474	952.5474
	151	954.0-960.0	955.25	957.0	959.75	955.2625	959.7625	954.0477	958.5477
	152	960.0-966.0	961.25	963.0	965.75	961.2625	965.7625	960.0480	964.5480
	153	966.0-972.0	967.25	969.0	971.75	967.2625	971.7625	966.0483	970.5483
	154	972.0-978.0	973.25	975.0	977.75	973.2625	977.7625	972.0486	976.5486
	155	978.0-984.0	979.25	981.0	983.75	979.2625	983.7625	978.0489	982.5489
	156	984.0-990.0	985.25	987.0	989.75	985.2625	989.7625	984.0492	988.5492
	157	990.0-996.0	991.25	993.0	995.75	991.2625	995.7625	990.0495	994.5495
	158	996.0-1002.0	997.25	999.0	1001.75	997.2625	1001.7625	996.0498	1000.5498

1. This column is for historical channel listings.

2. Aeronautical channels visual carrier frequency tolerance +/-5 kHz.

# NTSC (M) Cable Television Frequencies for Japan

Japan uses NTSC (M) but has different channel assignments. See [Table E-5](#).

**Table E-5 Japanese Channel Assignments**

Channel Number	Bandwidth (MHz)	Visual Carrier (MHz)	Center Frequency	Aural Carrier (MHz)
1	90.0-96.0	91.25	93.00	95.75
2	96.0-102.0	97.25	99.00	101.75
3	102.0-108.0	103.25	105.00	107.75
4	170.0-176.0	171.25	173.00	175.75
5	176.0-182.0	177.25	179.00	181.75
6	182.0-188.0	183.25	185.00	187.75
7	188.0-194.0	189.25	191.00	193.75
8	192.0-198.0	193.25	195.00	197.75
9	198.0-204.0	199.25	201.00	203.75
10	204.0-210.0	205.25	207.00	209.75
11	210.0-216.0	211.25	213.00	215.75
12	216.0-222.0	217.25	219.00	221.75
C13	108.0-114.0	109.25	111.00	113.75
C14	114.0-120.0	115.25	117.00	119.75
C15	120.0-126.0	121.25	123.00	125.75
C16	126.0-132.0	125.25	129.00	131.75
C17	132.0-138.0	133.25	135.00	137.75
C18	138.0-144.0	139.25	141.00	143.75
C19	144.0-150.0	145.25	147.00	149.75
C20	150.0-156.0	151.25	153.00	155.75
C21	156.0-162.0	157.25	159.00	161.75
C22	164.0-170.0	165.25	167.00	169.75
C23	222.0-228.0	223.25	225.00	227.75
C24	230.0-236.0	231.25	233.00	235.75
C25	236.0-242.0	237.25	239.00	241.75
C26	242.0-248.0	243.25	245.00	247.75
C27	248.0-254.0	249.25	251.00	253.75
C28	254.0-258.0	253.25	257.00	257.75
C29	258.0-264.0	259.25	261.00	263.75
C30	264.0-270.0	265.25	267.00	269.75
C31	270.0-276.0	271.25	273.00	275.75
C32	276.0-282.0	277.25	279.00	281.75

Table E-5 Japanese Channel Assignments (continued)

Channel Number	Bandwidth (MHz)	Visual Carrier (MHz)	Center Frequency	Aural Carrier (MHz)
C33	282.0-288.0	283.25	285.00	287.75
C34	288.0-294.0	289.25	291.00	293.75
C35	294.0-300.0	295.25	297.00	299.75
C36	300.0-306.0	301.25	303.00	305.75
C37	306.0-312.0	307.25	309.00	311.75
C38	312.0-318.0	313.25	315.00	317.75
C39	318.0-324.0	319.25	321.00	323.75
C40	324.0-330.0	325.25	327.00	329.75
C41	330.0-336.0	331.25	333.00	335.75
C42	336.0-342.0	337.25	339.00	341.75
C43	342.0-348.0	343.25	345.00	347.75
C44	348.0-354.0	349.25	351.00	353.75
C45	354.0-360.0	355.25	357.00	359.75
C46	360.0-366.0	361.25	363.00	365.75
C47	366.0-372.0	367.25	369.00	371.75
C48	372.0-378.0	373.25	375.00	377.75
C49	378.0-384.0	379.25	381.00	383.75
C50	384.0-390.0	385.25	387.00	389.75
C51	390.0-396.0	391.25	393.00	395.75
C52	396.0-402.0	397.25	399.00	401.75
C53	402.0-408.0	403.25	405.00	407.75
C54	408.0-414.0	409.25	411.00	413.75
C55	414.0-420.0	415.25	417.00	419.75
C56	420.0-426.0	421.25	423.00	425.75
C57	426.0-432.0	427.25	429.00	431.75
C58	432.0-438.0	433.25	435.00	437.75
C59	438.0-444.0	439.25	441.00	443.75
C60	444.0-450.0	445.25	447.00	449.75
C61	450.0-456.0	451.25	453.00	455.75
C62	456.0-462.0	457.25	459.00	461.75
C63	462.0-468.0	463.25	465.00	467.75

# PAL/SECAM Cable Television Channels and Relative Frequencies

Table E-6 provides information on the Phase Alternating Line (PAL) and SEquential Couleur Avec Memoire (SECAM) frequency map for standard 7- and 8-MHz channel bands in Europe.

The FCS (reference subaltern frequency) for color integration is different for different countries. Also, the channel and frequency designations are different for different countries. For a summary of the ITU designations for PAL and SECAM systems and Recommendation ITU-R BT.470.6 standards, refer to Table E-1, Table E-2, and Table E-3 on page E-2. These tables provide general information that may help determine frequency allocations for specific countries. Table E-6 is a frequency allocation table for PAL B and G locations. Also note that some countries use different schemes for VHF and UHF.

More information can be found at the websites listed on page E-1.



## Note

The downstream frequency plan includes all center frequencies between 112 and 858 MHz on 250-kHz increments. It is up to the operator to decide which frequencies to use to meet national and network requirements.

**Table E-6** Cable Television Channels and Relative Frequencies, PAL B and G

Channel Number	Bandwidth (MHz)	Visual Carrier (MHz)	Aural Carrier (MHz)
E2	47.0-54.0	48.25	53.75
E3	54.0-61.0	55.25	60.75
E4	61.0-68.0	62.25	67.75
S3	118.0-125.0	119.25	124.75
S4	125.0-132.0	126.25	131.75
S5	132.0-139.0	133.25	138.75
S6	139.0-146.0	140.25	145.75
S7	146.0-153.0	147.25	152.75
S8	153.0-160.0	154.25	159.75
S9	160.0-167.0	161.25	166.75
S10	167.0-174.0	168.25	173.75
E5	174.0-181.0	175.25	180.75
E6	181.0-188.0	182.25	187.75
E7	188.0-195.0	189.25	194.5
E8	195.0-202.0	196.25	201.75
E9	202.0-209.0	203.25	208.75
E10	209.0-216.0	210.25	215.75
E11	216.0-223.0	217.25	222.75
E12	223.0-230.0	224.25	229.75
S11	230.0-237.0	231.25	236.75



**Table E-6** Cable Television Channels and Relative Frequencies, PAL B and G (continued)

<b>Channel Number</b>	<b>Bandwidth (MHz)</b>	<b>Visual Carrier (MHz)</b>	<b>Aural Carrier (MHz)</b>
S12	237.0-244.0	238.25	243.75
S13	244.0-251.0	245.25	250.75
S14	251.0-258.0	252.25	257.75
S15	258.0-265.0	259.25	264.75
S16	265.0-272.0	266.25	271.75
S17	272.0-279.0	273.25	278.75
S18	279.0-286.0	280.25	285.75
S19	286.0-293.0	287.25	289.75
S20	293.0-300.0	294.25	299.75
S21	302.0-310.0	303.25	308.75
S22	310.0-318.0	311.25	316.75
S23	318.0-326.0	319.25	324.75
S24	326.0-334.0	327.25	332.75
S25	334.0-342.0	335.25	340.75
S26	342.0-350.0	343.25	348.75
S27	350.0-358.0	351.25	356.75
S28	358.0-366.0	359.25	364.75
S29	366.0-374.0	367.25	372.05
S30	374.0-382.0	375.25	380.75
S31	382.0-390.0	383.25	388.75
S32	390.0-398.0	391.25	396.75
S33	398.0-406.0	399.25	404.75
S34	406.0-414.0	407.25	412.75
S35	414.0-422.0	415.25	420.75
S36	422.0-430.0	423.25	428.75
S37	430.0-438.0	431.25	436.75
S38	438.0-446.0	439.25	444.75
S39	446.0-454.0	447.25	452.75
S40	454.0-462.0	455.25	460.75
S41	462.0-470.0	463.25	468.75
21	470.0-478.0	471.25	476.75
22	478.0-486.0	479.25	484.75
23	486.0-494.0	487.25	492.75
24	494.0-502.0	495.25	500.75
25	502.0-510.0	503.25	508.75

**Table E-6** Cable Television Channels and Relative Frequencies, PAL B and G (continued)

Channel Number	Bandwidth (MHz)	Visual Carrier (MHz)	Aural Carrier (MHz)
26	510.0-518.0	511.25	516.75
27	518.0-526.0	519.25	524.75
28	526.0-534.0	527.25	532.75
29	534.0-542.0	535.25	540.75
30	542.0-550.0	543.25	548.75
31	550.0-558.0	551.25	556.75
32	558.0-566.0	559.25	564.75
33	566.0-574.0	567.25	572.75
34	574.0-582.0	575.25	580.725
35	582.0-590.0	583.25	588.75
36	590.0-598.0	591.25	596.75
37	598.0-606.0	599.25	604.75
38	606.0-614.0	607.25	612.75
39	614.0-622.0	615.25	620.75
40	622.0-630.0	623.25	628.75
41	630.0-638.0	631.25	636.75
42	638.0-646.0	639.25	644.75
43	646.0-654.0	647.25	652.75
44	654.0-662.0	655.25	660.75
45	662.0-670.0	663.25	668.75
46	670.0-678.0	671.25	676.75
47	678.0-686.0	679.25	684.75
48	686.0-694.0	687.25	692.75
49	694.0-702.0	695.25	700.75
50	702.0-710.0	703.25	708.75
51	710.0-718.0	711.25	716.75
52	718.0-726.0	719.25	724.75
53	726.0-734.0	727.25	732.75
54	734.0-742.0	735.25	740.75
55	742.0-750.0	743.25	748.75
56	750.0-758.0	751.25	756.75
57	758.0-766.0	759.25	764.75
58	766.0-774.0	767.25	772.75
59	774.0-782.0	775.25	780.75
60	782.0-790.0	783.25	788.75

**Table E-6** Cable Television Channels and Relative Frequencies, PAL B and G (continued)

<b>Channel Number</b>	<b>Bandwidth (MHz)</b>	<b>Visual Carrier (MHz)</b>	<b>Aural Carrier (MHz)</b>
61	790.0-798.0	791.25	796.75
62	798.0-806.0	799.25	804.75
63	806.0-814.0	807.25	812.75
64	814.0-822.0	815.25	820.75
65	822.0-830.0	823.25	828.75
66	830.0-838.0	831.25	836.75
67	838.0-846.0	839.25	844.75
68	846.0-854.0	847.25	852.75
69	854.0-862.0	855.25	860.75





# APPENDIX **F**

## Manufacturers for Headend Provisioning Requirements

Table F-1 and Table F-2 provide information on some of the manufacturers, websites, and product offerings required to prepare and provision a North American cable headend site for two-way data. Table F-3 and Table F-4 provide information on some of the manufacturers, websites, and product offerings required to prepare and provision a European cable headend site for two-way data.

### North American Channel Plans

**Table F-1** *Manufacturers for North American Headend Provisioning Requirements*

Manufacturer	Website or Phone Number	Products/Model
<b>Diplex Filters</b>		
Eagle Comtronics	<a href="http://www.eaglecomtronics.com">http://www.eaglecomtronics.com</a>	Diplex filters
Microwave Filter Company, Inc.	<a href="http://www.microwavefilter.com">http://www.microwavefilter.com</a>	Diplex filters
ATX Networks	<a href="http://atxnetworks.com/">http://atxnetworks.com/</a>	Diplex filters
Viewsonics	<a href="http://www.viewsonics.com">http://www.viewsonics.com</a>	Diplex filters
<b>Coaxial Jumpers, Attenuators, Splitters, and Taps</b>		
Viewsonics	<a href="http://www.viewsonics.com">http://www.viewsonics.com</a>	Variable attenuators, Comb generators, Cisco uBR kit (splitter, diplex filter, attenuators)
Vecima	<a href="http://www.vecima.com">http://www.vecima.com</a>	Cisco uBR kit (splitter, diplex filter, attenuators)
White Sands Engineering, Inc <sup>1</sup> .	<a href="http://www.whitesandsengineering.com">http://www.whitesandsengineering.com</a> 1 800-jumpers or 602 581-0331	Coaxial jumpers
<b>GPS Receivers</b>		
Agilent <sup>2</sup>	<a href="http://www.agilent.com">http://www.agilent.com</a>	Agilent 85960B, 85961B
Symmetricon	<a href="http://www.symmetricon.com">http://www.symmetricon.com</a>	TS2500, TS2700, TS3000

1. Asheridge Communications Limited is the European and Middle Eastern partner for White Sands Engineering and their URL is <http://www.ashcatv.com>  
 2. Formerly Hewlett-Packard Test and Measurement Division.

In addition, we recommend the following manufacturers, websites, and product offerings for various measurement devices you will need to prepare and provision a North American cable headend site for two-way data. See [Table F-2](#).

**Table F-2** *Manufacturers for North American Headend Measurement Devices*

Manufacturer	Website or Phone Number	Products/Model
<b>Digital Signal Level Meters/QAM Analyzers</b>		
Acterna	<a href="http://www.acterna.com">http://www.acterna.com</a>	SDA-5000, w/Option 4B
Agilent <sup>1</sup>	<a href="http://www.agilent.com">http://www.agilent.com</a>	Agilent 8594Q, N1776A
Telsey <sup>2</sup>	<a href="http://www.telsey.it">http://www.telsey.it</a>	DMA120, DMA122
Sencore	<a href="http://www.sencore.com">http://www.sencore.com</a>	QAM-B970
Sunrise Telecom <sup>3</sup>	<a href="http://www.sunrisetelecom.com">http://www.sunrisetelecom.com</a>	CR1200R, AT2000RQ
Trilithic	<a href="http://www.trilithic.com">http://www.trilithic.com</a>	860DSP w/Option QA1
<b>Spectrum Analyzers</b>		
Agilent	<a href="http://www.agilent.com">http://www.agilent.com</a>	Agilent 8591C, N1776A
Tektronics	<a href="http://www.tek.com">http://www.tek.com</a>	2715
Sunrise Telecom	<a href="http://www.sunrisetelecom.com">http://www.sunrisetelecom.com</a>	AT2000R
<b>Vector Signal Analyzers</b>		
Agilent	<a href="http://www.agilent.com">http://www.agilent.com</a>	Agilent 89411A

1. Formerly Hewlett-Packard Test and Measurement Division.
2. Formerly Tektronics DMA division.
3. Formerly Hukk Engineering and Avantron.

# European Channel Plans

**Table F-3** *Manufacturers for European Headend Provisioning Requirements*

<b>Manufacturer</b>	<b>Website or Phone Number</b>	<b>Products/Model</b>
<b>Diplex Filters</b>		
Eagle Comtronics	<a href="http://www.eaglecomtronics.com">http://www.eaglecomtronics.com</a>	Diplex filters
Microwave Filter Company, Inc.	<a href="http://www.microwavefilter.com">http://www.microwavefilter.com</a>	Diplex filters
ATX Networks	<a href="http://atxnetworks.com/">http://atxnetworks.com/</a>	Diplex filters
Viewsonics	<a href="http://www.viewsonics.com">http://www.viewsonics.com</a>	Diplex filters
<b>Coaxial Jumpers, Attenuators, Splitters, and Taps</b>		
Viewsonics	<a href="http://www.viewsonics.com">http://www.viewsonics.com</a>	Variable attenuators, Comb generators, Cisco kit (splitter, diplex filter, attenuators, coaxial jumpers)
Vecima	<a href="http://www.vecima.com">http://www.vecima.com</a>	Cisco uBR kit (splitter, diplex filter, attenuators)
White Sands Engineering, Inc.	<a href="http://www.whitesandsengineering.com">http://www.whitesandsengineering.com</a> 1 800-jumpers or 602 581-0331	Coaxial jumpers
<b>GPS Receivers</b>		
Agilent <sup>1</sup>	<a href="http://www.agilent.com">http://www.agilent.com</a>	Agilent 85960B, 85961B
Symmetricom	<a href="http://www.symmetricom.com">http://www.symmetricom.com</a>	TS2500, TS2700, TS3000

1. Formerly Hewlett-Packard Test and Measurement Division.

In addition, we recommend the following manufacturers, websites, and product offerings for various measurement devices you will need to prepare and provision a European cable headend site for two-way data.

**Table F-4** *Manufacturers for European Headend Measurement Devices*

Manufacturer	Website or Phone Number	Products/Model
<b>Digital Signal Level Meters/QAM Analyzer</b>		
Acterna	<a href="http://www.acterna.com">http://www.acterna.com</a>	SDA-5000 w/Option 4B
Agilent <sup>1</sup>	<a href="http://www.agilent.com">http://www.agilent.com</a>	Agilent 8594Q, N1776A
Sunrise Telecom <sup>2</sup>	<a href="http://www.sunrisetelecom.com">http://www.sunrisetelecom.com</a>	AT2000RQ
Swires Research	<a href="http://www.swire.com">http://www.swire.com</a>	TVA 2000-Q
Telsey <sup>3</sup>	<a href="http://www.telsey.it">http://www.telsey.it</a>	DMA121, DMA122
Trilithic	<a href="http://www.trilithic.com">http://www.trilithic.com</a>	860DSP w/Option QA1
<b>Spectrum Analyzers</b>		
Agilent	<a href="http://www.agilent.com">http://www.agilent.com</a>	Agilent 8591C
Tektronix	<a href="http://www.tek.com">http://www.tek.com</a>	2715
Sunrise Telecom	<a href="http://www.sunrisetelecom.com">http://www.sunrisetelecom.com</a>	AT2000R
<b>Vector Signal Analyzers</b>		
Agilent	<a href="http://www.agilent.com">http://www.agilent.com</a>	Agilent 89411A

1. Formerly Hewlett-Packard Test and Measurement Division.
2. Formerly Hukk Engineering and Avantron.
3. Formerly Tektronics DMA division.





## APPENDIX **G**

### Site Log

---

A site log provides a historical record of all actions relevant to the Cisco uBR7225VXR universal broadband router operation and maintenance. Keep your site log in a common place near the chassis where anyone who performs tasks has access to it. Site log entries might include the following:

- Installation progress—Make a copy of the [“Cisco uBR7225VXR Router Installation Checklist” section on page 3-1](#), and insert it into the site log. Make entries on the Installation Checklist as each procedure is completed.
- Upgrades and removal and replacement procedures—Use the site log as a record of system maintenance and expansion history. Each time a procedure is performed on the system, update the site log to reflect the following:
  - Cable interface line cards installed, removed, or replaced
  - Network processing engine removed, replaced, or upgraded
  - Power supply removed or replaced
  - Redundant power supply installed
  - Chassis replaced
  - Subchassis and midplane replaced
  - Configuration changed; cable interface line cards moved
  - Memory upgraded
  - Software upgraded
  - Corrective maintenance procedures performed
  - Intermittent problems
  - Related comments

[Table G-1](#) shows a sample site log page. Make copies of the sample or design your own site log to meet the needs of your site and equipment.





## GLOSSARY

---

### Symbols

- 10Base-T** 10-Mbps baseband Ethernet specification using two pairs of twisted-pair cabling (Category 3, 4, or 5): one pair for transmitting data and the other for receiving data. 10Base-T, which is part of the IEEE 802.3 specification, has a distance limit of approximately 328 feet (100 meters) per segment.
- 100Base-T** 100-Mbps baseband Fast Ethernet specification using UTP wiring. Like the 10Base-T technology on which it is based, 100Base-T sends link pulses over the network segment when no traffic is present. However, these link pulses contain more information than those used in 10Base-T. The 100Base-T specification is based on the IEEE 802.3 standard.
- 802.x** IEEE standards for the definition of LAN protocols.
- 1000Base-LX/LH** 1000-Mbps Gigabit Ethernet specification using two strands of multimode or single-mode fiber-optic cable per link. To guarantee proper signal recovery, a 1000Base-LX/LH link cannot exceed 1804 feet (550 meters) in length over multimode fiber or 32,810 feet (10 km) in length over single-mode fiber. Based on the IEEE 802.3 standard with reach over single-mode fiber extended from 5 km to 10 km.
- 1000Base-SX** 1000-Mbps Gigabit Ethernet specification using two strands of multimode fiber-optic cable per link. To guarantee proper signal recovery, a 1000Base-SX link cannot exceed 1804 feet (550 meters) in length. The 1000Base-SX specification is based on the IEEE 802.3 standard.
- 1000Base-X** 1000-Mbps Gigabit Ethernet specification that refers to the 1000Base-ZX, 1000Base-SX, and 1000Base-LX standards for Gigabit Ethernet over fiber-optic cabling. The 1000Base-X specification is based on the IEEE 802.3 standard.
- 1000Base-ZX** 1000-Mbps Gigabit Ethernet specification using two strands of single-mode fiber-optic cable per link. To guarantee proper signal recovery, a 1000Base-ZX link cannot be longer than 62.1 miles (100 km). This is a Cisco specification.

---

### A

- AAA server** Authorization, authentication, and accounting server.
- Alarm** A status condition that shows that a module or port is experiencing an abnormal operating condition. See also [Critical alarm](#), [Major alarm](#), and [Minor alarm](#).
- AS/NZS** Australia/New Zealand.
- ATM** Asynchronous Transfer Mode. International standard for cell relay in which multiple service types (such as voice, video, or data) are conveyed in fixed-length (53-byte) cells. Fixed-length cells allow cell processing to occur in hardware, thereby reducing transit delays. ATM is designed to take advantage of high-speed transmission media such as E3, SONET, and T3.

---

**B**

**BER** Bit error rate.

---

**C**

**CATV** Cable television. References to headend or distribution hub.

**CCS** Common channel signaling.

**CES** Circuit emulation service.

**Chrominance** The color portion of a video signal.

**CMTS** Cable modem termination system, such as the Cisco uBR7225VXR router.

**C/N ratio** Carrier-to-noise ratio.

**CNR** Cisco Network Registrar.

**CPE** Customer premises equipment.

**Critical alarm** An alarm condition that might affect most or all subscribers that connect to the reporting node. To obtain more information about a problem, use the **show facility-alarm status** command. See also [Major alarm](#) and [Minor alarm](#).

**CSRC** Cisco Subscriber Registration Center.

**CSU/DSU** Channel service unit/data service unit.

**CTS** Clear To Send.

---

**D**

**DCD** Data carrier detect.

**DCE** Data circuit-terminating equipment (ITU-T expansion). Devices and connections of a communications network that comprise the network end of the user-to-network interface. The DCE provides a physical connection to the network, forwards traffic, and provides a clocking signal used to synchronize data transmission between DCE and DTE devices. Modems and interface cards are examples of DCE. Compare with [DTE](#).

**DHCP** Dynamic Host Configuration Protocol.

**DNS** Domain Name System.

**DOCSIS** Data-over-Cable Service Interface Specification.

**DSR** Data set ready.

- DSU** Data Service Unit. Device used in digital transmission that adapts the physical interface on a DTE device to a transmission facility such as T1 or E1. The DSU is also responsible for such functions as signal timing. Often used with CSU, as in CSU/DSU.
- DTE** Data terminal equipment. Device at the user end of a user-network interface that serves as a data source, destination, or both. DTE connects to a data network through a DCE device (for example, a modem) and typically uses clocking signals generated by the DCE. DTE includes devices such as computers, protocol translators, and multiplexers.

---

**E**

- EIA** Electronic Industries Alliance.
- EMI** Electromagnetic interference.
- EPROM** Erasable programmable read-only memory.
- ESD** Electrostatic discharge.
- EuroDOCSIS** European Data-over-Cable Service Interface Specifications.

---

**F**

- Fast Ethernet** Any of a number of 100-Mbps Ethernet specifications. Fast Ethernet offers a speed increase 10 times that of the 10Base-T Ethernet specification, while preserving qualities such as frame format, MAC mechanisms, and MTU. Existing 10Base-T applications and network management tools can be used on Fast Ethernet networks. The Fast Ethernet specification is based on an extension to the IEEE 802.3 specification.
- FEC** Forward error correction.
- Flash memory** Nonvolatile storage that can be electrically erased and reprogrammed so that software images can be stored, booted, and rewritten as necessary. Flash memory was developed by Intel and is licensed to other semiconductor companies.
- FRU** Field-replaceable unit. A component that can be removed from a network device and replaced in the field. Line cards, power modules, and fan modules are typically FRUs.

---

**G**

- GPS** Global positioning system.

---

**H**

- H.323 VoIP network** Protocol that supports VoIP.

<b>HDLC</b>	High-Level Data Link Control.
<b>HFC</b>	Hybrid fiber-coaxial.
<b>HSSI</b>	High-Speed Serial Interface.

---

**I**

<b>IEC</b>	International Electrotechnical Commission.
<b>IEEE 802.3</b>	IEEE LAN protocol that specifies an implementation of the physical layer and the MAC sublayer of the data link layer. IEEE 802.3 uses CSMA/CD access at a variety of speeds over a variety of physical media. Extensions to the IEEE 802.3 standard specify implementations for Fast Ethernet and Gigabit Ethernet.
<b>ITU-T</b>	International Telecommunication Union-Telecommunications Standardization Sector.
<b>ITU-T J.83 Annex A</b>	Series J.83 deals with the transmission of television, sound programming, and other multimedia signals. Annex A defines the management interface between the customer premises equipment and the Frame Relay network for European channel plans.

---

**M**

<b>MAC</b>	Media Access Control.
<b>Major alarm</b>	One of a group of alarm conditions that are considered the second most severe of all reportable alarms. Major alarms affect several subscribers who connect to the reporting node. You can use the <b>show facility-alarm status</b> Cisco IOS command to obtain more information about the problem. See also <a href="#">Critical alarm</a> and <a href="#">Minor alarm</a> .
<b>MER</b>	Modulation error ratio.
<b>Minor alarm</b>	One of a group of alarm conditions that are considered the third most severe of all reportable alarms. Minor alarms affect a single or small number of subscribers who connect to the reporting node. You can use the <b>show facility-alarm status</b> Cisco IOS command to obtain more information about the problem. See also <a href="#">Critical alarm</a> and <a href="#">Major alarm</a> .
<b>MSO</b>	Multiple system operator.

---

**N**

<b>NCTA</b>	National Cable Television Association.
<b>NPE</b>	Network processing engine.
<b>NSE</b>	Network services engine.

**NTSC** National Television System Committee.

**NVRAM** Nonvolatile random-access memory.

---

**O**

**OIR** Online insertion and removal.

---

**P**

**PAL** Phase alternating line.

**PCI** Protocol control information.

---

**Q**

**QAM** Quadrature amplitude modulation. A modulation technique using variations in simple amplitude.

**QPSK** Quaternary phase shift keying. A compression technique used in modems and wireless networks.

---

**R**

**RTS** Request to send.

---

**S**

**SDH** Synchronous Digital Hierarchy.

**SDRAM** Synchronous dynamic random-access memory.

**SECAM** SEquential Couleur Avec Memoire.

**SGCP** Simple Gateway Control Protocol.

**SONET** Synchronous Optical Network. High-speed synchronous network specification developed by Bellcore and designed to run on optical fiber. STS-1 is the basic building block of SONET. It was approved as an international standard in 1988.

**SRAM** Static random-access memory.

**STB** Set-top box.

---

**T**

<b>T1</b>	Digital WAN carrier facility. T1 transmits DS1-formatted data at 1.544 Mbps through the telephone switching network.
<b>TAC</b>	Technical Assistance Center.
<b>ToD</b>	Time of day.
<b>TFTP</b>	Trivial File Transfer Protocol.

---

**U**

<b>UBR</b>	Universal broadband router.
<b>UTP</b>	Unshielded twisted-pair.

---

**V**

<b>VoIP</b>	Voice over IP.
<b>VPN</b>	Virtual private network.
<b>VXR</b>	Voice Extension Ready.

---

**X**

<b>X-level test point</b>	A test point that is established by inserting a test signal of known amplitude into a fiber node and then measuring the output level amplitude at the headend optical receiver.
---------------------------	---





## INDEX

---

### A

AAA server [2-13](#)  
access server [2-12](#)  
adapter pinouts [C-3](#)  
addresses, MAC [1-5](#)  
air exhaust [5-4](#)  
airflow [1-16, 2-16](#)  
attenuator manufacturers [F-1, F-3](#)  
authorization, authentication, and accounting server, see AAA server  
auxiliary port [C-3](#)  
auxiliary port, pinouts [C-4](#)

---

### B

banner, system [3-19](#)

---

### C

cable headend configurations, overview [1-6](#)  
cable interface line cards [1-12, 6-6](#)  
cable management bracket  
    how to install [3-6](#)  
cable-management bracket  
    4-post rack [3-6](#)  
    how to install [3-10](#)  
    requirements [3-5](#)  
cable-management kit, using [2-17](#)  
cable network configurations, overview [1-6](#)  
cables  
    AC power [1-13](#)  
    Category 3 or 5 UTP [C-4](#)

    connecting [3-14](#)  
    crossover [C-4, C-5](#)  
    Fast Ethernet ports [C-4](#)  
    interference [2-14](#)  
    return loss [C-2](#)  
    rollover [C-2](#)  
    safety guidelines [2-4](#)  
    straight-through [C-4, C-5](#)  
    swapping power [6-4](#)  
    ungrounded and uninsulated [2-4](#)  
    wire gauge [C-1](#)  
Category 3 or 5 UTP RJ-45 cables [C-4](#)  
CATV mode [4-11 to 4-17](#)  
caution  
    chassis, overheating [2-17](#)  
    network processing engine removal while system operating [5-2](#)  
channel range [1-6](#)  
channel rates [B-1](#)  
chassis  
    clearance [2-16](#)  
    footprint [2-15](#)  
    height [2-15](#)  
    installation [1-2](#)  
    lifting [2-2](#)  
    warning against stacking [3-12](#)  
chassis airflow [1-16](#)  
checklist [3-2](#)  
    installation [3-1](#)  
    site preparation [2-17](#)  
Cisco Network Registrar [1-7, 2-12](#)  
Cisco Subscriber Registration Center [1-7](#)  
Cisco uBR900 [6-7](#)

clearance, for air circulation [2-16](#)

clipping [4-4](#)

coaxial jumper manufacturers [F-1, F-3](#)

color codes

- optical fiber [D-2](#)
- small wiring groups [D-5](#)
- telephone wire [D-3](#)

commands

- show environment [2-6, 5-3, 5-5](#)

configuration tools [1-7](#)

configuring

- digital data [4-1](#)
- digital signal [4-40](#)
- RF data [4-1](#)
- RF signal [4-4](#)
- typical cable headend [4-2, 4-3](#)

configuring the console port [3-15](#)

connecting to power [3-16, 3-17](#)

connection equipment

- auxiliary port signals [3-15](#)
- console and auxiliary [3-14](#)
- console port signals [3-15](#)

console port, cables

- console port [C-3](#)

console terminal, system banner display [6-3](#)

cooling subsystem [6-2](#)

crossover cables [C-4, C-5](#)

---

## D

damage from overheating [5-2](#)

Data-over-Cable Service Interface Specifications [1-1, 2-12, 4-24, 4-34, 4-36](#)

data packets [4-25, 4-26](#)

data transmission, verify downstream signals [6-7](#)

described [i-xii](#)

DHCP server [2-12](#)

digital data signals [4-3](#)

digital signal level meter manufacturers [F-2, F-4](#)

diplex filter manufacturers [F-1, F-3](#)

diplex filters [2-11](#)

displays, environmental [5-3](#)

distance limitations, transmission [2-14](#)

DNS server [2-12](#)

DOCSIS [2-12](#)

- transfer configuration files [2-12](#)

DOCSIS 1.0 parameters [B-2](#)

DOCSIS 1.1 parameters [B-5](#)

downstream

- connecting and configuring [4-4](#)
- measuring laser transmitter forward test point [4-37 to 4-40](#)
- measuring RF signal [4-5 to 4-17](#)

---

## E

EEPROM, MAC address bank [1-5](#)

electrical input and output [B-8](#)

electrical noise [4-3](#)

electromagnetic pulse, avoiding [2-14](#)

EMI, shielding [2-4](#)

environmental monitor, description [5-2](#)

environmental specifications [2-6](#)

Environmental status [5-4](#)

equipment, CMTS [2-12](#)

EuroDOCSIS [1-1, 2-12, B-6](#)

examples

- show environment all command output [5-5](#)
- show environment command output [5-4](#)
- show environment last command output [5-4](#)

exhaust air [5-4](#)

---

## F

faceplate [1-11](#)

fan failures [5-6](#)

fan tray [1-2, 1-14, 1-16](#)

Fast Ethernet [C-4](#)

fiber-optic laser receivers [2-11](#)  
 field notices [6-7](#)  
 field-replaceable units, see FRUs [1-10](#)  
 flash memory card replacement instructions [1-12](#)  
 frequency allocation
 

- NTSC [E-1](#)
- NTSC (M) [E-8](#)
- NTSC standards [E-3](#)
- PAL standard [E-10](#)
- related websites [E-1](#)
- SECAM standard [E-10](#)
- standards comparisons [E-2](#)

 FRUs
 

- fan tray [1-14](#)
- network processing engine [1-10](#)

---

## G

Gigabit Ethernet [1-4](#)  
 GPS receiver manufacturers [F-1](#), [F-3](#)  
 gravity, maintaining low center [2-16](#)

---

## H

handles [1-13](#), [2-4](#)  
 handling cards [2-4](#)  
 hardware address [1-4](#)  
 hardware components, overview [1-10](#)  
 headend certification [2-11](#)  
 headend configurations, overview [1-6](#)  
 headend provisioning [2-10](#)  
 headend provisioning, required network information [2-7](#)  
 hybrid fiber-coaxial (HFC) [C-1](#)

---

## I

identifying startup problems [6-3](#)  
 IF

channel power [4-6](#)  
 measuring the signal [4-5](#), [?? to 4-7](#)  
 impulse noise [4-3](#)  
 ingress noise [4-3](#)  
 installation
 

- analyzing the RF [4-1](#)
- before you begin [2-7](#)
- checking the shipping container [2-9](#)
- checklist [3-1](#)
- connecting cables [3-14](#)
- connecting power [3-16](#)
- equipment [2-9](#)
- ESD [2-4](#)
- general [3-12](#)
- headend setup [4-1](#)
- initial configuration information [2-7](#)
- preparing for [4-1](#)
- rack-mounting the chassis [3-2](#)
- safety guidelines [2-1](#)
- safety recommendations [2-1](#)
- site requirements [2-5](#)
- tools [2-8](#)

 installation checklist [3-2](#)  
 installing chassis in a rack [3-2](#)  
 installing chassis on a tabletop [3-12](#)  
 interference, radio frequency [2-14](#)  
 intermediate frequency (IF) [4-11](#)  
 Internet access overview [1-6](#)  
 IP telephony network example [1-8](#)  
 IP telephony overview [1-8](#)  
 ITU-T J.83 [1-1](#)

---

## J

Japan, frequency allocations [E-8](#)  
 jewelry, avoiding for safety [2-2](#)

**K**

kits [2-8](#)

**L**

LEDs

cable interface line cards [6-6](#)

enabled [3-19](#)

power subsystem [6-4](#)

power supply [6-3](#)

lifting the chassis [2-2](#)

lightning storm, safety during [2-4](#)

**M**

MAC addresses [1-4, 1-5](#)

Means [i-xi](#)

measuring amplitude [4-26](#)

messages [2-6](#)

messages, environmental [5-3](#)

midplane [1-2, 1-17](#)

modulation [1-1](#)

**N**

network example [1-7](#)

network interface [1-4](#)

network processing engine [1-1](#)

description [1-10](#)

subsystem for troubleshooting [6-5](#)

system management functions [1-10](#)

upgradable memory modules [1-11](#)

noise

amplified thermal [4-3](#)

electrical [4-3](#)

funneling [4-4](#)

impulse [4-3](#)

ingress [4-3](#)

outside plant [4-28](#)

normal status level, environmental monitor [5-4](#)

NTSC (M) frequency allocations [E-8](#)

NTSC frequency allocation [E-3](#)

NTSC standard, description [E-1](#)

NVRAM log [5-3](#)

**O**

OIR [1-2, 5-1](#)

online insertion and removal, see OIR

operating conditions for chassis [A-1](#)

out-of-tolerance temperature condition [5-2](#)

out-of-tolerance voltage condition [5-2](#)

overheating, preventing [2-6](#)

overtemperature conditions [6-3](#)

**P**

packet [4-28](#)

packetized voice [1-1](#)

PAL [1-1, E-1](#)

PAL frequency allocation [E-10](#)

PAL standard, description [E-1](#)

parameters

downstream RF channel characteristics [B-2, B-4, B-6](#)

electrical input and output [B-8](#)

upstream RF channel characteristics [B-3, B-5](#)

upstream RF channel characteristics,  
EuroDOCSIS [B-7](#)

pass-through [2-13](#)

PCI bus [1-4](#)

ping [4-25, 4-26, 4-27](#)

pinouts [C-3, C-4](#)

power [3-19](#)

AC, site requirements [2-5](#)

cord [1-13, 6-4](#)

cord safety [2-1](#)

- emergency power-off switch [2-3](#)
- subsystem, for troubleshooting [6-2](#)
- surge suppression [2-14](#)
- ungrounded [2-3](#)

power connections

- AC power [3-17](#)
- overview [3-16](#)

power factor corrector, power supply [2-5](#)

power rating [4-39, 4-40](#)

power supply [1-1](#)

- LEDs [6-3](#)
- physical description [1-13](#)
- shutdown [5-3](#)
- troubleshooting [6-3](#)

preamble power [4-30](#)

preparing for two-way data operation [2-10](#)

problem solving, subsystem [6-2](#)

procedures

- cable interface line cards
  - cables [3-14](#)
- checking the shipping container [2-9](#)
- connecting power [3-16](#)
- general installation [3-12](#)
- rack-mounting the chassis [3-2](#)

processor shutdown [5-3](#)

processor troubleshooting [6-2](#)

provisioning [2-12, 2-13](#)

- AAA server [2-13](#)
- access server [2-12](#)
- diplex filters [2-11](#)

---

## Q

- QAM analyzer manufacturers [F-2, F-4](#)
- QPSK data points [4-32](#)
- QPSK demodulation mode [4-32](#)

---

## R

- rack-mount installation [3-1](#)
- rack-mount kit [2-10, 3-2](#)
- radio frequency interference (see RFI) [2-14](#)
- RADIUS dial server [2-12](#)
- rate, symbol [B-1](#)

RF

- analyzing the upstream signal [4-25](#)
- configuring the signal [4-4](#)
- measuring the signal [4-5](#)
- measuring the upstream signal [4-22](#)
- specifications [B-1, B-2](#)

RFI [2-14](#)

RJ-45 connector [C-2, C-4](#)

RJ-45 connector pinout

- 10BASE-T [C-5](#)
- DB-25 adapter [C-4](#)
- DB-9 adapter [C-3](#)

rollover cables [C-2](#)

router overview [1-1](#)

---

## S

- safety recommendations [2-1](#)
- SECAM [1-1](#)
- SECAM frequency allocation [E-10](#)
- SECAM standard, description [E-1](#)
- See [1-3](#)
- show commands
  - show environment [2-6, 5-3, 5-5](#)
  - show environment last [5-4](#)
- shutdown [5-2, 5-6](#)
- signal level meter [4-5](#)
- signal loss [4-4](#)
- site log [G-1](#)
- site preparation checklist [2-17](#)
- site requirements [2-5](#)
  - AC power [2-5](#)

environment [2-5](#)  
 equipment racks [2-15](#)  
 general precautions [2-6](#)  
 plant wiring [2-14](#)  
 power considerations [2-7](#)  
 slot/port numbers for interfaces [1-4](#)  
 SNMP, management [1-11](#)  
 specifications [A-1](#)  
 spectrum analyzer, using
 

- CATV mode option [4-11](#)
- channel power option [4-5 to 4-11](#)
- measure RF signal [4-5 to 4-17](#)

 spectrum analyzer manufacturers [F-2, F-4](#)  
 splitter manufacturers [F-1, F-3](#)  
 startup, system [3-18](#)  
 status, environmental [2-6](#)  
 straight-through cables [C-4, C-5](#)  
 subchassis, physical description [1-17](#)  
 subsystems for troubleshooting
 

- network processing engine [6-5](#)
- power [6-4](#)

 symbol [4-28, 4-34](#)  
 symbol rate [6-7, B-1, B-8](#)  
 symbol rate combinations [4-28](#)  
 system configurations, overview [1-6](#)  
 system specifications [A-1](#)

---

## T

tap manufacturers [F-1, F-3](#)  
 telco return, overview [1-9](#)  
 telco-type equipment racks [2-15, 3-1](#)  
 telephone jacks [2-4](#)  
 temperature, internal chassis [5-2](#)  
 test points
 

- calibrating [4-21](#)
- HFC network [4-20](#)

 TFTP server [2-12](#)  
 This [5-1](#)

thresholds, shutdown [5-2](#)  
 TIA/EIA standards information [D-2](#)  
 time domain [4-30](#)  
 time-of-day (TOD) server [2-12](#)  
 tools, for installation [2-8](#)  
 transmission characteristics [B-2, B-3, B-4, B-5, B-7](#)  
 troubleshooting
 

- cable interface line cards [6-6](#)
- cooling subsystem [6-4](#)
- identifying startup problems [6-3](#)
- network processing engine [6-5](#)
- power subsystem [6-4](#)
- processor subsystem [6-5](#)
- strategy [6-2](#)
- websites [6-7](#)

---

## U

upconverter manufacturers [F-1](#)  
 upstream
 

- analyzing RF signal [4-25 to 4-28](#)
- connecting and configuring [4-18 to 4-21](#)
- measuring RF signal [4-22 to 4-28](#)

 upstream data burst [4-28, 4-30](#)

---

## V

variable transmit levels [4-4](#)  
 vector signal analyzer manufacturers [F-2, F-4](#)  
 video averaging [4-6](#)  
 voice over IP, see VoIP  
 VoIP [1-8, 2-13](#)  
 VPN example [1-8](#)

---

## W

warning
 

- chassis lifting [3-11, 3-12](#)

- grounded equipment [3-17](#)
- installation [3-16](#)
- jewelry removal [3-17](#)
- lightning activity [2-4](#)
- power supply disconnection [2-4](#)
- product disposal [2-2](#)
- qualified personnel [2-2](#)
- safety precautions [3-10](#)
- service personnel [2-2](#)
- stacking the chassis [3-12](#)
- supply circuit [3-16](#)
- telecommunications lines [2-4](#)
- TN power [3-17](#)
- weight [1-3](#)
- wiring
  - interference [2-14](#)
  - optical color codes [D-2](#)
  - plant [2-14](#)
  - telephone [2-4](#)
  - telephone color codes [D-3](#)
  - telephone station, terminal color codes [D-5](#)

---

## X

- X-level test points [4-20](#)

---

## Z

- zero-span [4-28](#)





## Free Manuals Download Website

<http://myh66.com>

<http://usermanuals.us>

<http://www.somanuals.com>

<http://www.4manuals.cc>

<http://www.manual-lib.com>

<http://www.404manual.com>

<http://www.luxmanual.com>

<http://aubethermostatmanual.com>

Golf course search by state

<http://golfingnear.com>

Email search by domain

<http://emailbydomain.com>

Auto manuals search

<http://auto.somanuals.com>

TV manuals search

<http://tv.somanuals.com>