

# INSTRUCTIONS



**6106**

Indoor WDR Color IR Dome Camera

**6128**

Outdoor WDR Vandal-Proof IR Color Dome Camera

 **CHANNEL VISION™**

©2011 CHANNEL VISION TECHNOLOGY

# Contents

1. SAFETY PRECAUTIONS.....	2
2. INTRODUCTION .....	3
3. FEATURES .....	4
4. PACKING LIST .....	5
5. NAME and FUNCTION of EACH PART .....	6
5.1 OSD Button (Menu): .....	6
6. INSTALLATION.....	7
6.1 Camera Installation & Operation.....	7
6.2 Connect to Monitor.....	10
6.3 Connect the Power.....	11
6.4 Connection Layout .....	12
6.4.1 Connecting the Keyboard .....	13
PELCO Keyboard (or compatible) Installation.....	13
6.4.2 Connecting the Alarm.....	14
7. OPERATION.....	15
7.1 PELCO Keyboard (or compatible) Operation.....	15
8. SYSTEM SETUP.....	16
8.1 Digital Zoom Operation: .....	16
8.2 OSD (On Screen Display) .....	16
8.3 Sub Menu Description.....	17
8.3.1 LENS TYPE .....	17
8.3.2 EXPOSURE Setup .....	17
8.3.4 WHITE BALANCE Setup .....	19
8.3.5 PRIVACY MASK Setup.....	20
8.3.6 EFFECT Setup: .....	21
8.3.7 NOISE REDUCTION Setup .....	23
8.3.8 MOTION DETECT Setup.....	23
8.3.9 COMMUNICATION Setup .....	24
8.3.10 DEFAULT Setup.....	25
8.3.11 EXIT Setup.....	25
9. SPECIFICATION.....	26

# 1. SAFETY PRECAUTIONS

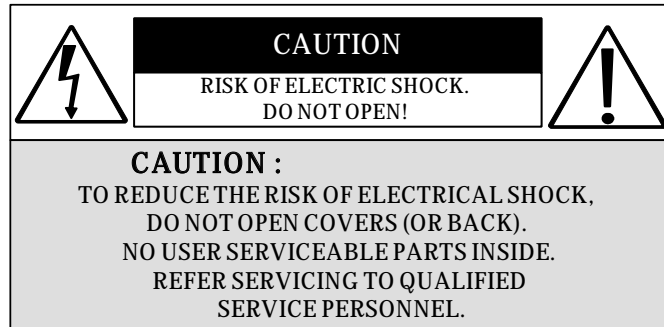

It is advised to read the Safety Precaution Guide through carefully before operating the product, to prevent any possible danger.

 **WARNING:** Alert the user to the presence of un-insulated dangerous voltage? .

 **CAUTION:** Alert the user the presence of important operating and maintenance (Servicing) instructions in the literature accompanying the appliance.



**Disposal of Old Electrical & Electronic Equipment (Applicable in the European Union and other European countries with separate collection systems).**

This symbol indicates that this product shall not be treated as household waste. Instead it shall be handed over to the applicable collection point for the recycling of electrical and electronic equipment. By ensuring this product is disposed of correctly, you will help prevent potential negative consequences for the environment and human health. For more detailed information about recycling of this product, please contact your local city office, your household waste disposal service or the shop where you purchased the product.

**Please be extra careful not to shake the product.**

**Please avoid places where frequent vibrations or shocks.**

**Do not install the product in extreme temperature conditions.**

Only use the camera under conditions where temperatures are between -10° and +50° . Be especially careful to provide ventilation when operating under high temperatures.

**Do not install the product in an environment where the humidity is high.**

Unless the product is waterproof or weatherproof, otherwise it can cause the image quality to be poor.

**Do not expose to strong light (sun rays), as color filters will be discolored.**

**Do not spill liquid of any kind on the product.**

If it gets wet, wipe it dry immediately. Alcohol or beverage can contain minerals that corrode the electronic components.

When any abnormal occurs, make sure to unplug the unit, and contact your local dealer.

## 2. INTRODUCTION

This WDR digital image camera uses a high resolution color Sony 1/3" interline transfer Charge Coupled Device (CCD) image sensor, producing clear images reaching 650 lines of horizontal resolution.

Using Super Wide Dynamic Range technology, this camera is able to capture both high-luminance and low luminance subjects under a wide variety of shooting conditions. 3-D Noise Reduction technology automatically reduces noise in low light environments after noise reduction. The camera provides motion detection warnings, offering comprehensive monitoring for added safety protection.



## 3. FEATURES

### **High Resolution**

CCD Sensor provides high resolutions reaching 650 TV lines with crisp, clear picture quality.

### **Wide Dynamic Range (WDR)**

High-quality WDR functionality, perfectly shows the image details between dark and light. The newly added environment dynamic detection switch enhances WDR image efficiency.

### **Day & Night**

IR cut-filter with AE automatically changes from color to B&W mode for day and night 24-hour surveillance. Selectable between manual Day & Night control or from external input signal Day & Night control.

### **Privacy Mask**

Privacy image masking with free position, supports up to 15 areas of privacy masking zones. Privacy area enlarges with the digital zoom-in function.

### **Lens (C/CS Mount)**

Built-in DC-type Vari-Focal lens with ICR.

### **OSD**

OSD (On Screen Display) Setup Menu.  
Camera tile setup of up to 16 alphanumeric characters

### **Application**

All functions can be operated from OSD: AES (Automatic Electronic Shutter), AI (Auto Iris), GC (Gain Control), WB (White Balance), BLC (Back Light compensation), and provides the flickerless mode, and line-lock function.

### **Excellent Sensitivity**

High sensitivity, low smear, high anti-blooming and high S/N ratio.

### **Digital Noise Reduction (DNR)**

2D/ 3D DNR, captures clear images in low light environments, saving DVR hard disk storage space when using MPEG/MPEG4/H.264 compression.

### **Digital Slow Shutter (DSS)**

When in low light, reduces the image frame refresh rate and increases the sensitivity of the camera.

### **Motion Detection**

Provides a motion detection alert for more comprehensive monitoring and specific editing of the motion detection area. When there are changes within the detection area, the camera immediately issues a warning.

### **Extra Connection**

Control the camera easily with the 5050 RS-485 interface; Connect the extra alarm out to combine with the motion detection function.

### **Image Control**

Performance: 16x digital zoom, freeze image, positive/ negative image, mirror function (left/ right), reverse turn (up/ down), and 180° rotation.

## 4. PACKING LIST

Check and make sure all the items shown below are included in your product package. If something is missing, contact your dealer as soon as possible.

### Dome (IR Type)



6106

6128

### User Manual

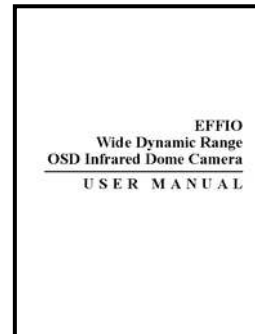

### Power Adaptor



### Accessories

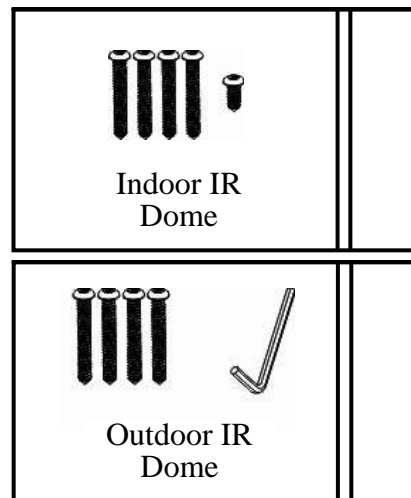

## 5. NAME and FUNCTION of EACH PART

### 5.1 OSD Button (Menu):

No.	Name	Function
1	UP	Digital Zoom-Out or Up direction button
2	DOWN	Digital Zoom-In or Down direction button
3	RIGHT	Increase Value ( + )
4	LEFT	Decrease Value ( - )
5	ENTER	Enter or Exit setup MENU

To adjust the OSD, remove the dome cover from the main body by gently turning the cover counter-clockwise to unlock and pull free from the main body. The OSD buttons can be found on the main body of the dome camera.

#### ■ Indoor IR Dome

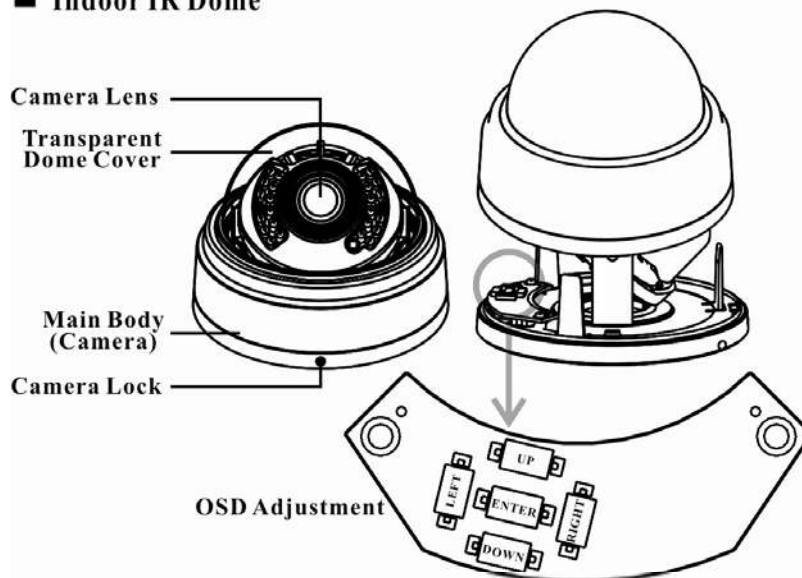

#### ■ Outdoor IR Dome

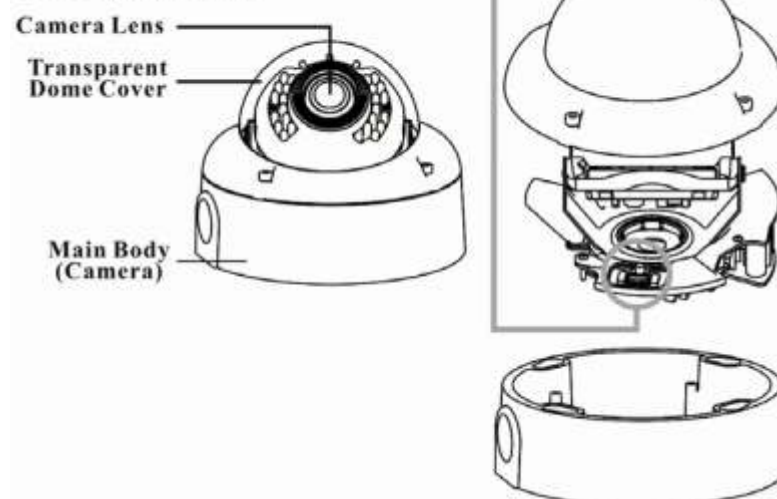

# 6. INSTALLATION

## 6.1 Camera Installation & Operation

### 1. Removing the Dome Cover

Remove the indoor dome cover from the main body by gently turning the cover counter-clockwise to unlock and pull free from the main body.

Remove the outdoor dome cover using the provided L-Wrench, loosen the screws securing the temper-resistant housing cover (with the screws still attached on the cover) to unlock the cover from the main body.

#### ■ Indoor IR Dome



#### ■ Outdoor IR Dome

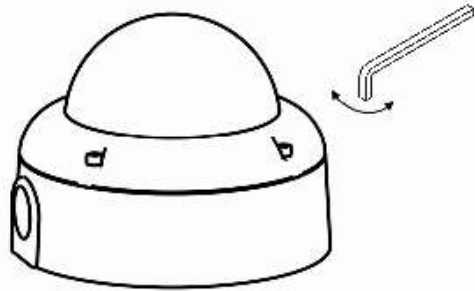

### 2. Camera Image Adjustment

You can adjust camera to any direction by using Pan, Tilt, and Rotate the mechanism.

Pan Base moves by  $360^\circ$  on the whole.

Tilt Base covers total  $119^\circ$  angle ( $64^\circ$  to one side and  $55^\circ$  to the other side).

Angle range of Rotate Base is  $360^\circ$ .

#### ■ Indoor IR Dome

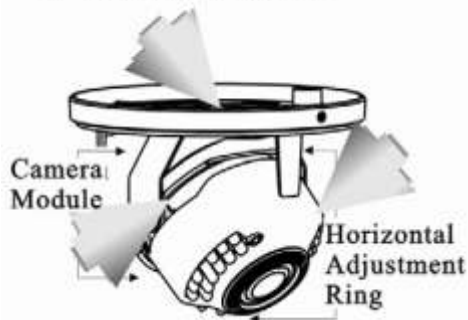

#### ■ Outdoor IR Dome

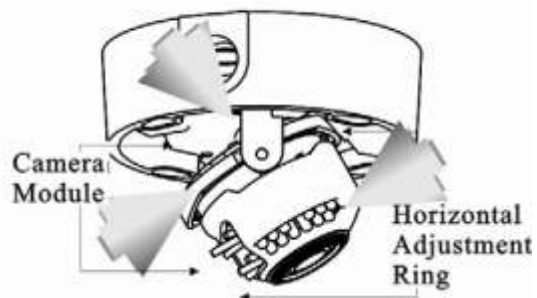



## Vari-Focal Lens with IR LED

### ■ 3-Axis Movement for Free Lens Rotation - Indoor

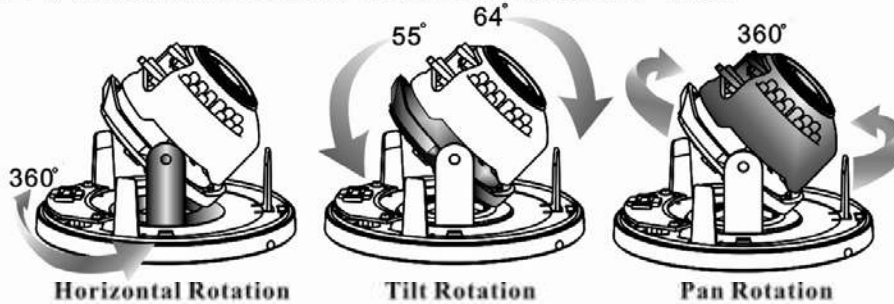

### ■ 3-Axis Movement for Free Lens Rotation - Outdoor

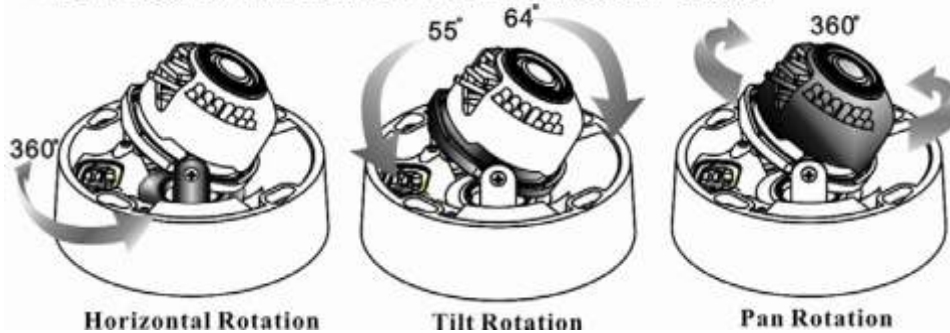

**Note:** This product is not suitable for horizontal 360° continuous rotation.

### 3. Adjusting the Vari-Focal Lens

Loosen the Zoom lever counter-clockwise several turns, and then rotate the Zoom lever to obtain the best image view.

Loosen the Focus lever counter-clockwise several turns, and then rotate the Focus lever to obtain the optimum picture quality.

Re-tighten the Zoom lever and Focus lever after adjustment.

#### ■ Indoor IR Dome

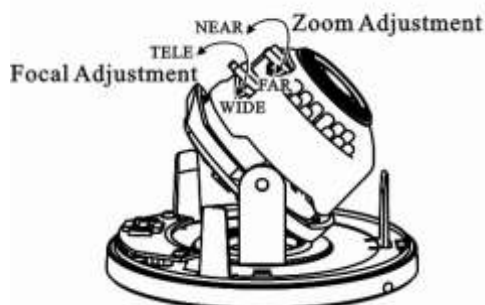

#### ■ Outdoor IR Dome

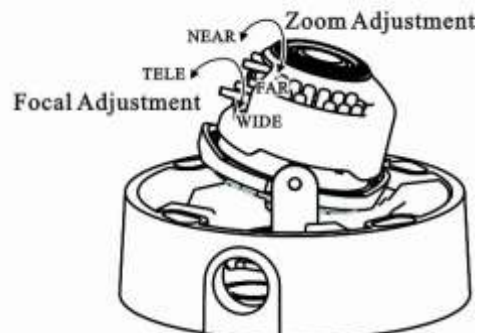

#### 4. Attaching the Dome Cover

After all the necessary adjustments have been made, reinstall the dome cover to the main body.

##### ■ Indoor IR Dome



##### ■ Outdoor IR Dome



- ⌘ Reinstall the indoor dome cover and the main body by turning the dome clockwise until it locks into place  
To prevent any damage or theft, lock-up the dome by using the countersunk head screw.

Reinstall the outdoor dome cover and the main body by using the provided L-Wrench to fasten the cover to the main body.

##### ■ Indoor IR Dome

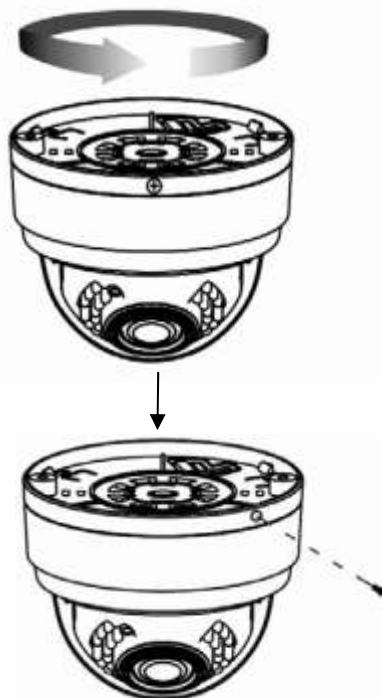

##### ■ Outdoor IR Dome



## 6.2 Connect to Monitor

Connect the Video-out port of the camera to a monitor. Since the connecting method varies depending on the instrument, refer to the manual supplied with the instrument for more information.

### ■ Indoor IR Dome

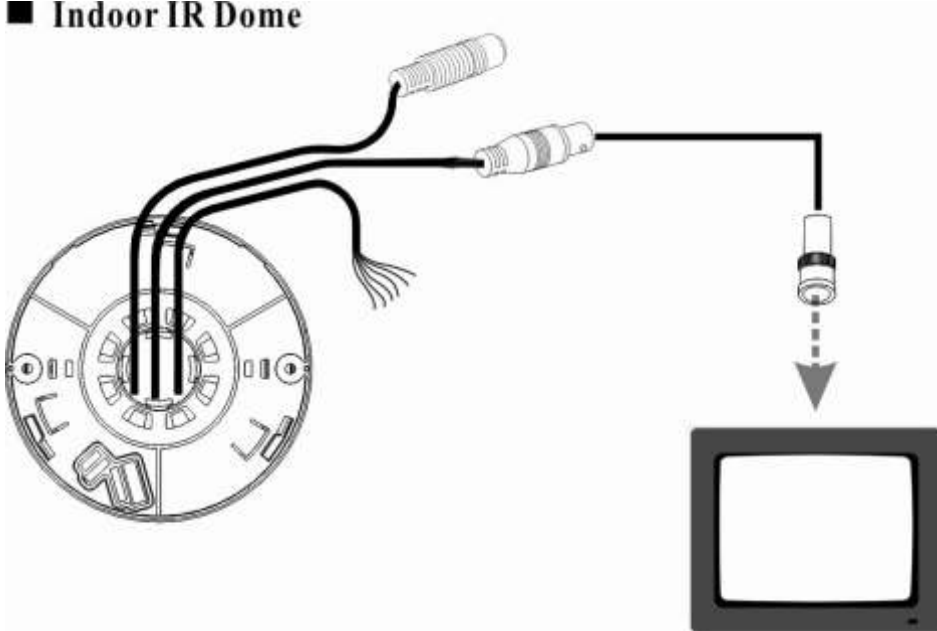

### ■ Outdoor IR Dome

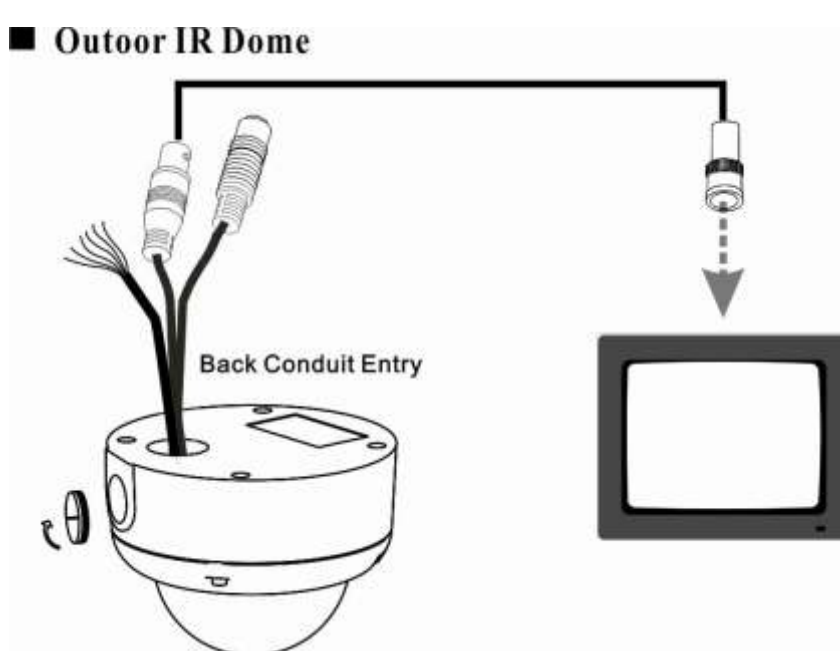

## 6.3 Connect the Power

Connect the indoor dome video output to a 75 Ohms type coaxial cable and the DC-Jack or AC/ DC-Terminator to the power source.

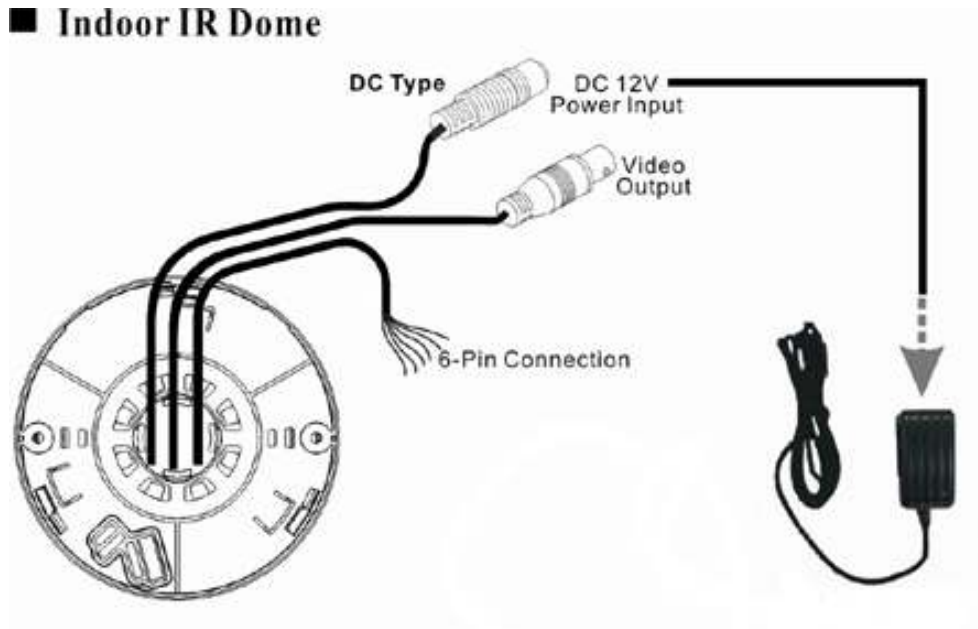

- ⌘ Connect the outdoor dome video output to a 75 Ohms type coaxial cable and the DC-Jack or AC/ DC-Terminator to the power source.  
When using conduit cabling, it is suggested to use a metal to cover over the cables to prevent external damage.  
To weatherproof, place weatherproof adhesive tape (P.T.F.E. THREAD SEAL TAPE) onto the metal cover before installation.

## ■ Outdoor IR Dome

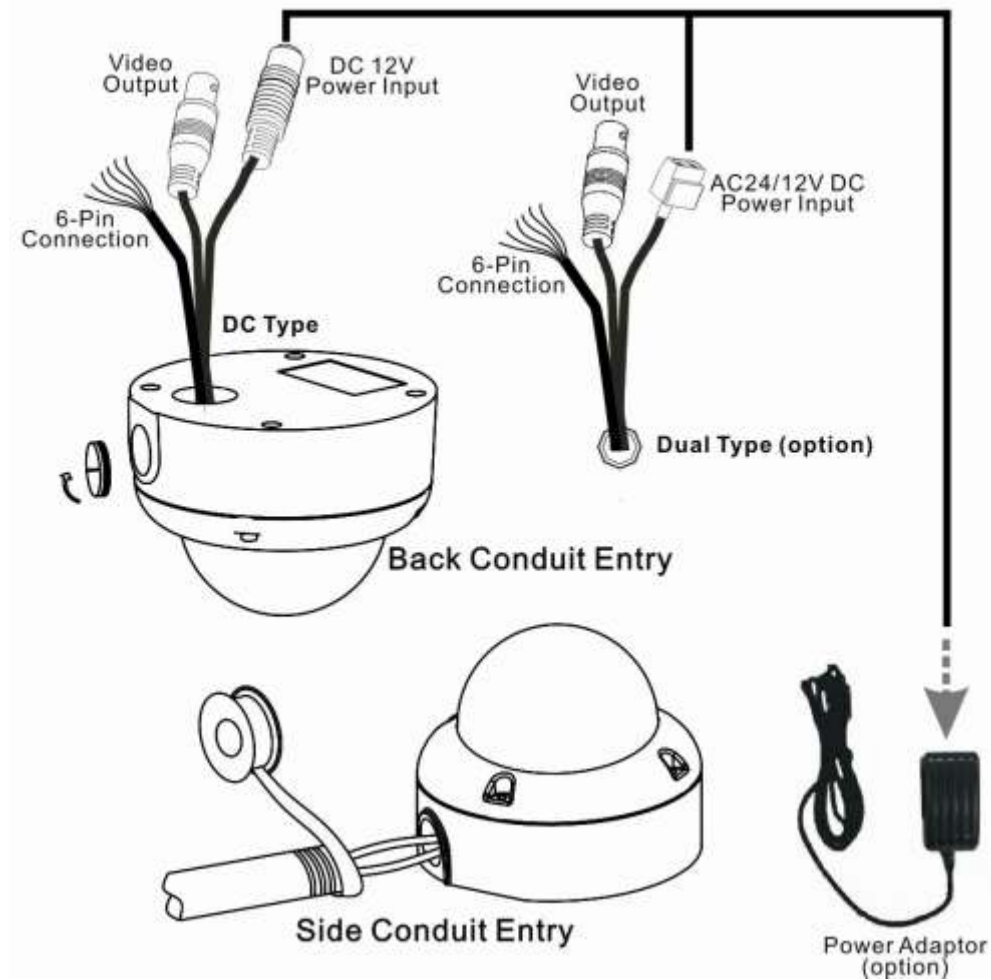

**Note:** Power adapter is sold separately.

## 6.4 Connection Layout

To connect the keyboard and alarm, please follow the setup guide shown below:

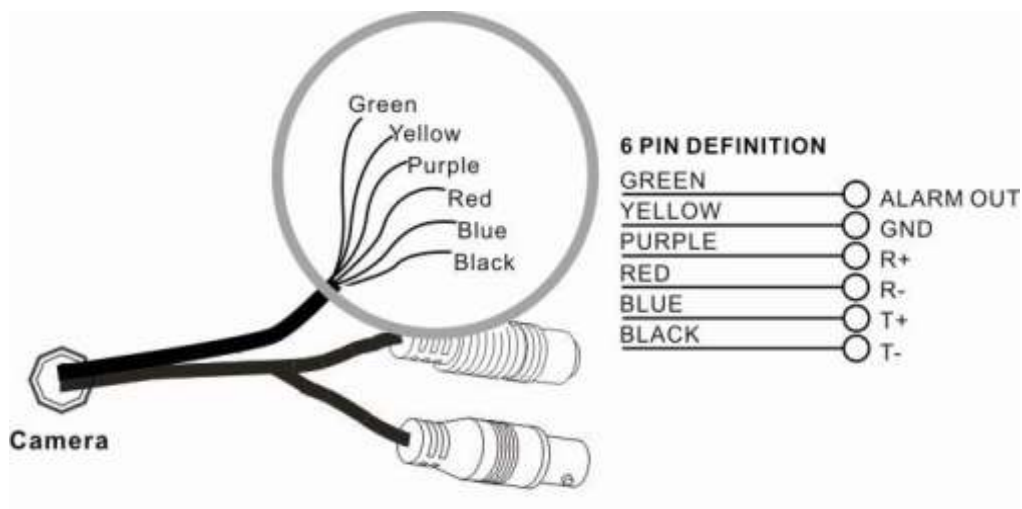

## 6.4.1 Connecting the Keyboard

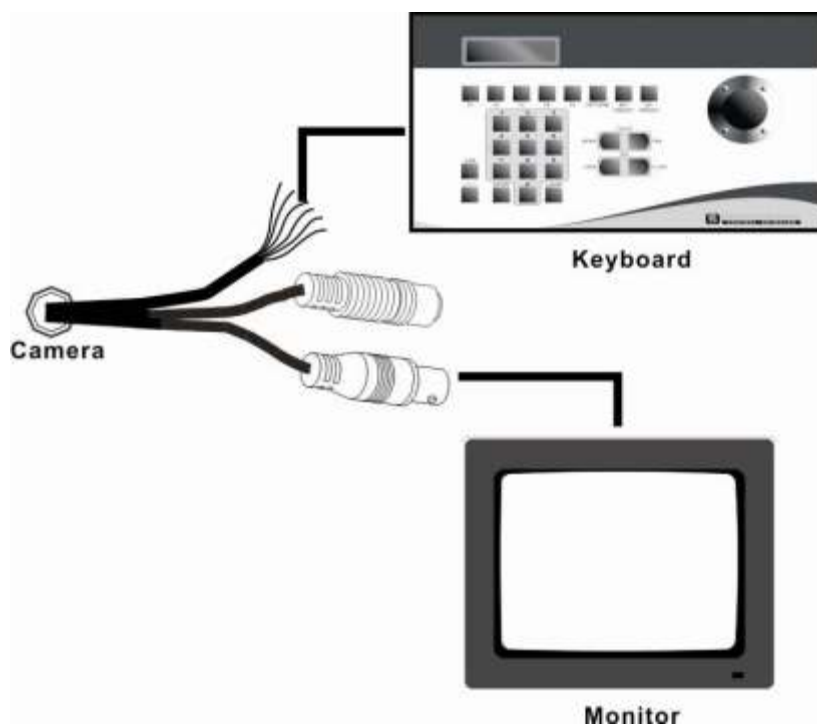

### PELCO Keyboard (or compatible) Installation

The RS-422 interface is used for communicating with a PELCO keyboard. Refer to Fig. 1; connect R+ of the camera to T+ of the PELCO keyboard. Connect R- of the camera to T- of the PELCO keyboard.

The user can adjust Camera ID via rear panel keys or via remote commands. Protocol, Speed and Parity should only be adjusted via rear panel keys.

Communication	Setting
CAMERA ID	0 ~ 253 for P protocol
	1 ~ 255 for D protocol
PROTOCOL	PELCO
SPEED	2400, 4800, 9600, 19200
PARITY	NONE

The speed of camera should be the same as the speed of the keyboard. Adjusted function is only effective, after exiting the OSD setup menu.

#### Note:

Maximum cable distance for RS-485 communication over 24-gauge wire is 4,000 feet (1,219 m). Recommend using a shielded twisted pair cable that meets the basic requirements for EIA RS-485 applications.

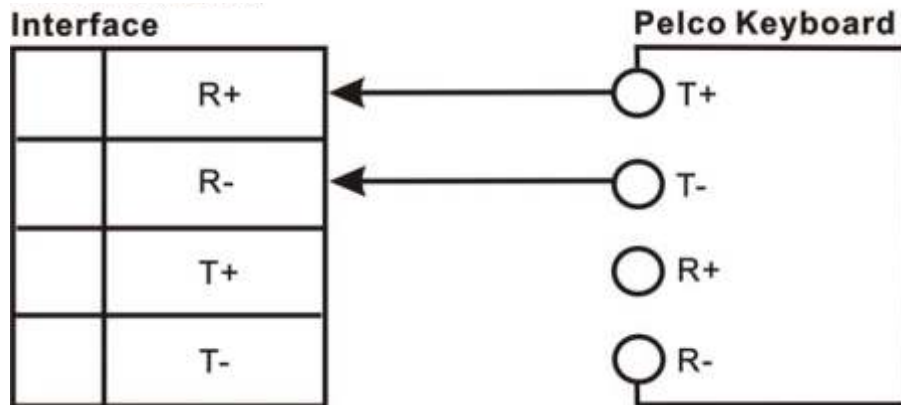
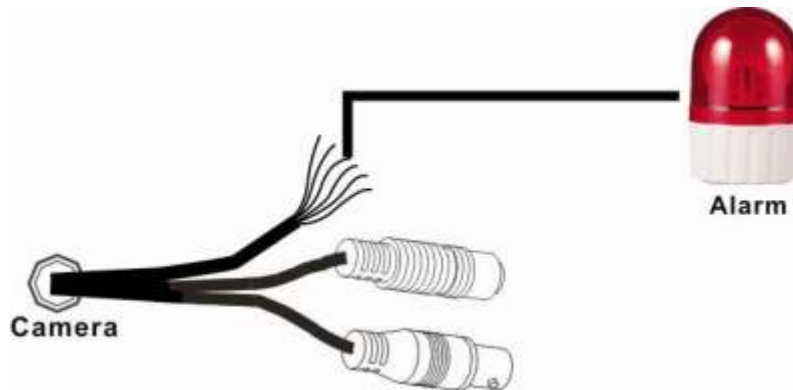

Fig.1

### 6.4.2 Connecting the Alarm



#### Alarm Installation

Connect GND and AL of the camera to the GND and AL of the alarm.

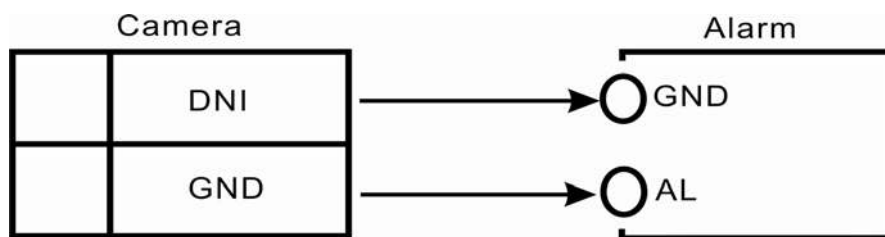

**Note:** The alarm is triggered by motion detection.

## 7. OPERATION

1. Mount the camera on the mounting bracket by using the hole on the top or bottom of the camera, and by using the enclosed mounting block, secured by 2 screws.
2. Connect the video output to the monitor or other video device via a 75 Ohms type coaxial cable.
3. Power Input Terminal (Dual Power): the camera accepts both AC 24V and DC 12 V power sources (non-polarity).

### 7.1 PELCO Keyboard (or compatible) Operation

#### Normal Display Mode

PELCO Keyboard	Camera Function
OPEN	Brightness +
CLOSE	Brightness -
Twist Joystick clockwise or Zoom In	Zoom Tele
Twist Joystick counterclockwise or Zoom Out	Zoom Wide
NEAR	None
FAR	None
Move Joystick Left	None
Move Joystick Right	None
Move Joystick Up	None
Move Joystick Down	None
Enter 95; Hold the PRESET key (approximately five seconds) until the main menu appears on the screen.	Accessing OSD Main Menu

**Note:**

CLOSE / OPEN adjustments are required to meet the EXPOSURE MODE settings, size LEVEL is only adjustable when the option is under [WDR], [BLC USER], and [NORMAL].

#### OSD Setup Menu Mode

PELCO Keyboard	Camera Function
OPEN	Sub Menu Enter
CLOSE	Sub Menu Exit
NEAR	Cursor Up
FAR	Cursor Down
Move Joystick Left	Decrease (-)
Move Joystick Right	Increase (+)
Move Joystick Up	Cursor Up
Move Joystick Down	Cursor Down
Twist Joystick clockwise or Zoom In	None
Twist Joystick counterclockwise or Zoom Out	None

**Note:**

Please refer to PELCO Keyboard (or compatible) manual for more information.



## 8. SYSTEM SETUP

### 8.1 Digital Zoom Operation:

Under normal display (before entering the OSD menu), use  $\overleftarrow{\wedge}$ (T)/  $\wedge$ (W) button to control the digital zoom (zoom range: 1 x ~ 16 x).

### 8.2 OSD (On Screen Display)

#### Main Menu Display

MAIN MENU	V.9729
LENS TYPE	MANUAL/DC
EXPOSURE	? ?
WHITE BALANCE	? ?
PRIVACY MASK	? ?
EFFECT	? ?
NOISE REDUCTION	? ?
MOTION DETECT	? ?
COMMUNICATION	? ?
DEFAULT	ON
EXIT	

#### Main Menu Setup

β In order to display the setup menu on the screen, set the menu command or press the button panel.

Use  $\square$  (T)/  $\square$  (W) control buttons to select each item.

Use ? (- )/ ? (+ ) control buttons to change the data.

Use MENU control button to ENTER/ EXIT the menu display.

#### <Note>

For maximum image quality it is suggested to use DC LENS PENTAX TS812E 8mm 1:1.2 CS.

## 8.3 Sub Menu Description

### 8.3.1 LENS TYPE

Built-in DC-type Vari-Focal lens with ICR (although the camera OSD supports both DC-type and Manual-type lenses, it is fixed to DC type because the camera is built-in only with a DC-type Vari-Focal lens).

### 8.3.2 EXPOSURE Setup

<b>EXPOSURE</b>	
MODE	[WDR]
AGC MAX	128
SHUTTER SPEED	AUTO
DESS MAX	OFF
DEFAULT	ON
RETURN	

1. MODE: There are four types of modes: [WDR] / [BLC SMART] / [BLCUSER] / [NORMAL]. When the function option is set to BLC SMART, it indicates that the backlight compensation is calculated by the system. Press MENU under [WDR] / [BLCUSER] / [NORMAL] mode to enter next page.

#### **[WDR] Setup:**

<b>WDR EXPOSURE</b>	
LEVEL	8
DEFAULT	ON
RETURN	

- (1) LEVEL: Setup range from 0-40 (Default Setup: 8).
- (2) DEFAULT: Return to Default Setup.
- (3) RETURN: Return to previous status.

**[BLCUSER] Setup:**

<b>BLC EXPOSURE</b>	
AREA	CENTER
START X	NA
END X	NA
START Y	NA
END Y	NA
LEVEL	7
DEFAULT	ON
RETURN	

- (1) AREA: Setup to BLC, the area is set as BLC area and under manual mode (1) CENTER (2) TOPS (3) TOPL (4) BOTTOMS (5) BOTTOMML (6) LEFT (7) RIGHT (Default Setup: NA).
- (2) START X: Horizontal start position (NA).
- (3) END X: Horizontal end position (NA).
- (4) START Y: Vertical start position (NA).
- (5) END Y: Vertical end position (NA).

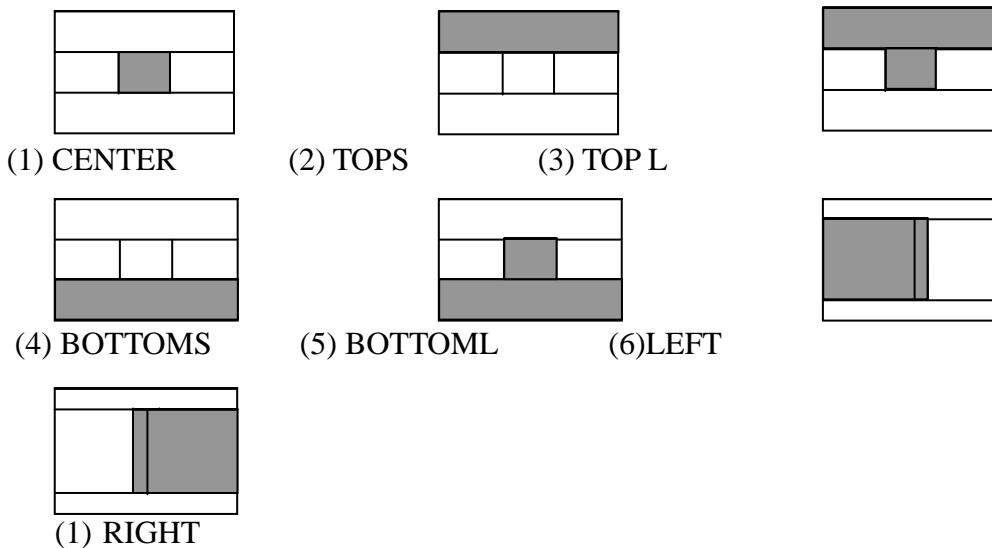

**[NORMAL] EXPOSURE Setup:**

<b>NORMAL EXPOSURE</b>	
LEVEL	96
DEFAULT	ON
RETURN	

- (1) LEVEL: Setup range from 0-255 (Default Setup: 96).
- (2) DEFAULT: Return to Default Setup.
- (3) RETURN: Return to previous status.

2. AGC MAX: Set AGC MODE to AUTO, AGC MAX setup range = 0~255.
3. SHUTTER SPEED consists of 9 types of modes: AUTO, NORMAL, FLICKERLESS (NTSC: 1/60 and PAL: 1/50), 1/250, 1/1000, 1/2000, 1/4000, 1/10000, 1/20000, 1/50000 and 1/100000 (Default Setup: NORMAL).
4. DSS MAX: Low speed shutter control, offers optimal brightness level. Therefore, in dark scene, raise the value higher than the the brightness level (Field Range: 2~256, Default Setup: OFF).
5. DEFAULT: Return to default setup.
6. RETURN: Return to previous status.

### 8.3.4 WHITE BALANCE Setup:

<b>WHITE BALANCE</b>	
WB MODE	AUTO
RED GAIN	NA
BLUE GAIN	NA
PUSH AUTO	NA
DEFAULT	ON
RETURN	▽◀

1. WB MODE: Five types of mode - AUTO, INDOOR, OUTDOOR, MANUAL, and PUSH AUTO (Default Setup: AUTO).
2. RED GAIN/ BLUE GAIN operate only when WB MODE is set to MANUAL, otherwise it is NA (Not Available).
3. When WB MODE is set to PUSH AUTO:
  - PUSH AUTO ON: Enable auto tracing white balance.
  - PUSH AUTO OFF: Depending on environment, disable auto tracing white balance and record the current white balance value.
4. DEFAULT: Return to default setup.
5. RETURN: Return to previous status.

### 8.3.5 PRIVACY MASK Setup:

<b>PRIVACY MASK</b>	
AREA	1
MASK	OFF
START X	20
END X	70
START Y	20
END Y	30
DEFAULT	ON
RETURN	▽◀

1. AREA: Maximum PRIVACY MASK area setting is 15 (Default Setup: 1).
2. MASK: Set MASK to "ON", MASK AREA becomes available for setup and is shown on the monitor (Default Setup: OFF).

<b>PRIVACY MASK</b>		
AREA	15	
MASK	ON	
START X	160	
END X	220	
	96	
	116	
DEFAULT	OFF	
▶ RETURN		

3. START X: Horizontal start position (0~240).
4. END X: Horizontal end position (0~240).
5. START Y: Vertical start position (0~150).
6. END Y: Vertical end position (0~150).
7. DEFAULT: Return to default setup.
8. RETURN: Return to previous status.

**Note:**

When the privacy mask has been enabled the motion area that has been covered by the privacy mask becomes ineffective.

### 8.3.6 EFFECT Setup:

<b>EFFECT</b>	
DISPLAY	▽◀
SHARPNESS	8
POSI/NEGA	POSI
MIRROR	OFF
FREEZE	OFF
SYNC	INT
V PHASE	NA
IRIS ADJ	▽◀
LANGUAGE	ENG
DEFAULT	ON
RETURN	▽◀

1. **DISPLAY:** Under this menu, a user can decide whether to reveal or hide TITLE DISP/ TITLE POS/ ID DISP/ ID POS/ZOOM DISP/ ZOOM POS. For more setup details on display, please follow the setup guide shown below:

#### DISPLAY Setup:

<b>DISPLAY</b>	
TITLE	~~~~~
TITLE DISP	ON
TITLE POS	RIGHT DOWN
ID DISP	ON
ID POS	RIGHT DOWN
ZOOM DISP	ON
ZOOM POS	LEFT DOWN
DEFAULT	ON
RETURN	▽◀

- (1) **TITLE:** You can enter up to 16 characters.

!	“	#	\$	%	&	'	(	)	*	+	,	-	.	/
0	1	2	3	4	5	6	7	8	9	:	;	<	=	>
?	@	A	B	C	D	E	F	G	H	I	J	K	L	M
N	O	P	Q	R	S	T	U	V	W	X	Y	Z	[	\
]	^	_	`	a	b	c	d	e	f	g	h	i	j	k
l	m	n	o	p	Q	r	s	t	u	v	w	x	y	z
{	}													

- (2) Four TITLE Setup Positions (TITLE/ ID/ ZOOM):  
RIGHT DOWN/ LEFT UP/ RIGHT UP/ LEFT DOWN (Default Setup: RIGHT DOWN).
- (3) Four ID Setup Positions:  
RIGHT DOWN/ LEFT UP/ RIGHT UP/ LEFT DOWN (Default Setup: RIGHT DOWN).
- (4) Four ZOOM Setup Positions:  
RIGHT DOWN/ LEFT UP/ RIGHT UP/ LEFT DOWN (Default Setup: RIGHT DOWN). Default Setup for Title/ ID/ ZOOM Display is "ON".
- (5) DEFAULT: Return to Default Setup.
- (6) RETURN: Return to previous status.
- 2. SHARPNESS: Video sharpness level setup: 0 ~15 (Default Setup: 8).
- 3. POSI/ NEGA: Images can be set to POSI (Positive Image) or NEGA (Negative Image). (Default Setup: POSI).
- 4. Four Types of MIRROR Mode: OFF/ HORIZONTAL/ VERTICAL/ ROTATE (Default Setup: Off).
- 5. FREEZE: Set FREEZE to "ON" to enable still field image (Default Setup: Off).
- 6. SYNC: Set to internal sync when using a DC 12V adaptor (Default Setup: INT). And to line-lock sync when using an AC 24V adaptor.
- 7. V PHASE: When L/L mode is selected, you can adjust the desired phase (0 ~ 358), otherwise it is an NA (Not Available) item (Default Setup: NA).
- 8. IRIS ADJ: When replacing the lens, face the camera toward the light, and then Select the option "ADJ". Message "ADJ..." means that adjustment is in progress, approx. about 10 ~ 30 seconds afterward a message "ADJ OK" appears indicates that the adjustment has been completed. When the message "Time Out" or "ADJ ERR" appears indicates that the adjustment has failed.
- 9. LANGUAGE: Select English/ Chinese as your OSD language display.
- 10. DEFAULT: Return to Default Setup.
- 11. RETURN: Return to previous status.

### 8.3.7 NOISE REDUCTION Setup:

NOISE REDUCTION	
NOISE REDUCE	ON
REDUCE LEVEL	MEDIUM
DEFAULT	ON
RETURN	▽◀

1. Enable/Disable 2D/3D Digital Noise Reduction function (Default Setup: ON).
2. Adjust three-dimension noise reduction level values: HIGH/ MEDIUM/ LOW.  
The higher the level, the better the noise reduction performance (Default Setup: MEDIUM).
3. DEFAULT: Return to default setup.
4. RETURN: Return to previous status.

### 8.3.8 MOTION DETECT Setup:

MOTION DETECT	
MOTION	OFF
AREA SET	□□
SENSITIVITY	10
DURATION	5 S
DEFAULT	ON
RETURN	□□

1. MOTION: Motion detection setup ON/ OFF (Default Setup: OFF).
2. AREA SET: Motion detection area setup ON/ OFF (Default Setup: OFF).

#### DETECTION AREA Setup:





Detection Block Setup: Press MENU button to enable or disable a single cell configuration setting Use up and down keys to move around or to end the setting mode. Press MENU button for 3 seconds to leave the setting page.

Keyboard Operation: Use the joystick to move the direction up, down, left or right and to move the cursor. Press ? IRIS OPEN? button to enable or disable a single cell configuration setting and press ? IRIS CLOSE? button to leave the Motion Mask Setting page.

3. SENSITIVITY: Detection sensitivity can be set to the range of 0 ~ 63 (Default Setup: 10).
4. DURATION: Alarm duration that arises after the motion alarm can be set to 5S / 10S / 15S / 20S / 30S / 1M / 2M / 3M / 4M / 5M (Default Setup: 5S). When an alarm has been triggered, a symbols "M" appears on the lower-left corner of the screen, and sends out a high Level 5V sound from the rear panel. When the alarm ends, the symbol "M" disappears, and sends out a Low Level sound from the rear panel.
5. DEFAULT: Return to default setup.
6. RETURN: Return to previous status.

### 8.3.9 COMMUNICATION Setup:

COMMUNICATION	
CAMERA ID	1
PROTOCOL	AUTO
SPEED	9600
PARITY	NONE
RETURN	□□

Please refer to ? 6. INSTALLATION? for more information on Communication.

### 8.3.10 DEFAULT Setup:

<b>MAIN MENU</b>		<b>V.9729</b>
LENS TYPE		MANUAL/DC
EXPOSURE		? ?
DAY/NIGHT		? ?
WHITE BALANCE		? ?
PRIVACY MASK		? ?
EFFECT		? ?
NOISE REDUCTION		? ?
MOTION DETECT		? ?
COMMUNICATION		? ?
> DEFAULT		ON
EXIT		

Select Default Settings and the system will return to its factory default settings. All user settings on the device will be erased.

### 8.3.11 EXIT Setup:

<b>MAIN MENU</b>		<b>V.9729</b>
LENS TYPE		MANUAL/DC
EXPOSURE		? ?
DAY/NIGHT		? ?
WHITE BALANCE		? ?
PRIVACY MASK		? ?
EFFECT		? ?
NOISE REDUCTION		? ?
MOTION DETECT		? ?
COMMUNICATION		? ?
DEFAULT		ON
> EXIT		

Select Exit Settings and the system will exit the menu page.

## 9. SPECIFICATION

Image Device	1/3" Color H-Res. Vertical Double-Density WD CCD (Sony Chipset)
Picture Elements	NTSC: 976 x 494 (H x V) / PAL: 976 x 582 (H x V)
Resolution	650 TVL
Min. Illumination	(0.0017) Lux(Day mode), (0.00011) Lux (Night mode) / F1.2
S/N Ratio	More than 48dB
Electronic Shutter	NTSC:1/60~1/100,000, PAL:1/50~1/100,000
Flickerless Mode	On / Off (NTSC:1/100, PAL:1/120)
Iris Control	DC Drive
Lens Mount	Vari-Focal IR Lens
Digital Noise Reduction	LOW/MID/HIGH
Motion detection	24*16 detection blocks
Gamma	0.45
White Balance	Auto / Indoor / Outdoor / Manual / Push Auto
Gain Control	Auto / Manual
Back Light Comp.	On / Off (Level & Area: user define and 7 default adjustable areas)
Wide Dynamic Range (WDR)	On / Off (Level adjustable), Auto detection
Day & Night (ICR)	Light Sensor
Digital Zoom	16x
Camera ID	000~255
Camera Title	Up to 16 characters
Mirror	Off / Horizontal / Vertical / Rotate
Privacy Masking	15 free areas (Area size adjustable)
Freeze	On / Off
Positive / Negative	On / Off
Digital Slow Shutter (DSS)	Off, 2~20, 40, 80, 160, 256 FLD
Remote Control	RS-485 / RS-422
Protocol	PELCO D&P
Sync. System	Internal / External Line Lock (AC only)
Video Output	1 Vp-p / 75 Ohms
Power Supply	DC12 V DC12V/AC24V Dual (Option, available only to outdoor IR Dome)
Power Consumption	Dual: (5.28) W max.
Operating Temp.	-10? ~ 50?



# CHANNEL VISION™

## 1 Year Limited Warranty

Channel Vision Technology will repair or replace any defect in material or workmanship which occurs during normal use of this product with new or rebuilt parts, free of charge in the USA, for one year from the date of original purchase. This is a no hassle warranty with no mail in warranty card needed. This warranty does not cover damages in shipment, failures caused by other products not supplied by Channel Vision Technology, or failures due to accident, misuse, abuse, or alteration of the equipment. This warranty is extended only to the original purchaser, and a purchase receipt, invoice, or other proof of original purchase date will be required before warranty repairs are provided.

Mail in service can be obtained during the warranty period by calling (800) 840-0288 toll free. A Return Authorization number must be obtained in advance and can be marked on the outside of the shipping carton.

This warranty gives you specific legal rights and you may have other rights (which vary from state to state). If a problem with this product develops during or after the warranty period, please contact Channel Vision Technology, your dealer or any factory-authorized service center.

Channel Vision products are not intended for use in medical, lifesaving, life sustaining or critical environment applications. Channel Vision customers using or selling Channel Vision products for use in such applications do so at their own risk and agree to fully indemnify Channel Vision for any damages resulting from such improper use or sale.



# CHANNEL VISION™

**channelvision.com**

234 Fischer Avenue, Costa Mesa, California 92626  
(714)424-6500 • (800)840-0288 • (714)424-6510 fax

500-301 Rev B

## Free Manuals Download Website

<http://myh66.com>

<http://usermanuals.us>

<http://www.somanuals.com>

<http://www.4manuals.cc>

<http://www.manual-lib.com>

<http://www.404manual.com>

<http://www.luxmanual.com>

<http://aubethermostatmanual.com>

Golf course search by state

<http://golfingnear.com>

Email search by domain

<http://emailbydomain.com>

Auto manuals search

<http://auto.somanuals.com>

TV manuals search

<http://tv.somanuals.com>