

Installation and Start-Up Instructions

NOTE: Read this entire instruction before beginning installation.

SAFETY CONSIDERATIONS

Improper installation, adjustment, alteration, service, maintenance, or use can cause explosion, fire, electrical shock or other conditions which may cause personal injury or property damage. Consult a qualified installer, service agency, or your distributor or branch for information or assistance. The qualified installer or agency must use factory-authorized kits or accessories when modifying this product. Refer to the individual instructions packaged with the kits or accessories when installing.

Follow all safety codes. Wear safety glasses and work gloves. Use quenching cloth for brazing operations. Have fire extinguisher available. Read these instructions thoroughly and follow all warning or cautions attached to the unit. Consult local building codes and National Electrical Code (NEC) for special requirements.

It is important to recognize safety information. This is the safety-alert symbol . When you see this symbol on the unit and in instructions or manuals, be alert to the potential for personal injury.

Understand the signal word— DANGER, WARNING, or CAUTION. These words are used with the safety-alert symbol. DANGER identifies the most serious hazards which will result in severe personal injury or death. WARNING signifies hazards that could result in personal injury or death. CAUTION is used to identify unsafe practices, which would result in minor personal injury or product and property damage.

WARNING

Before installing or servicing system, always turn off main power to system. There may be more than one disconnect switch. Turn off accessory heater power if applicable. Electrical shock can cause personal injury or death.

INSTALLATION

Step 1—Check Equipment and Jobsite

UNPACK UNIT

Move to final location. Remove carton taking care not to damage unit.

INSPECT EQUIPMENT

File claim with shipping company prior to installation if shipment is damaged or incomplete. Locate unit rating plate on unit service panel. (See Fig. 2.) It contains information needed to properly install unit. Check rating plate to be sure unit matches job specifications.

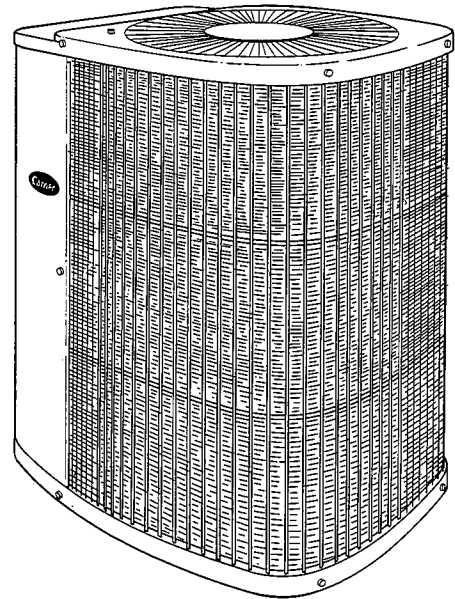

A88160

Fig. 1—Model 38TMA

Step 2—Install on a Solid, Level Mounting Pad

The minimum mounting pad dimensions are 26 in. x 32 in. (660.4mm x 812.8mm). If conditions or local codes require the unit be attached to pad, tiedown bolts should be used and fastened through knockouts provided in unit base pan. Refer to unit mounting pattern in Fig. 2 to determine base pan size and knockout hole location.

When installing, allow sufficient space for airflow clearance, wiring, refrigerant piping and service. Allow 30-in. (762mm) clearance to service end of unit and 48 in. (1219mm) above unit. For proper airflow, a 6-in. (152mm) clearance on one side of unit and 12 in. (305mm) on all remaining sides must be maintained. Maintain a distance of 24 in. (610mm) between air conditioners. Position so snow or ice from roof or eaves cannot fall directly on unit.

On rooftop applications, locate unit 6 in. (152mm) above roof surface. Where possible, place unit above a loadbearing wall.

Arrange supporting members to adequately support unit and minimize transmission of vibration to building. Consult local codes governing rooftop applications.

Step 3—Replace Indoor AccuRater® Piston, if Required

Check indoor coil piston to see if it matches the required piston shown on unit rating plate. If it does not match, replace indoor coil piston with piston shipped with this unit. The piston shipped with outdoor unit is correct for any approved indoor coil combination.

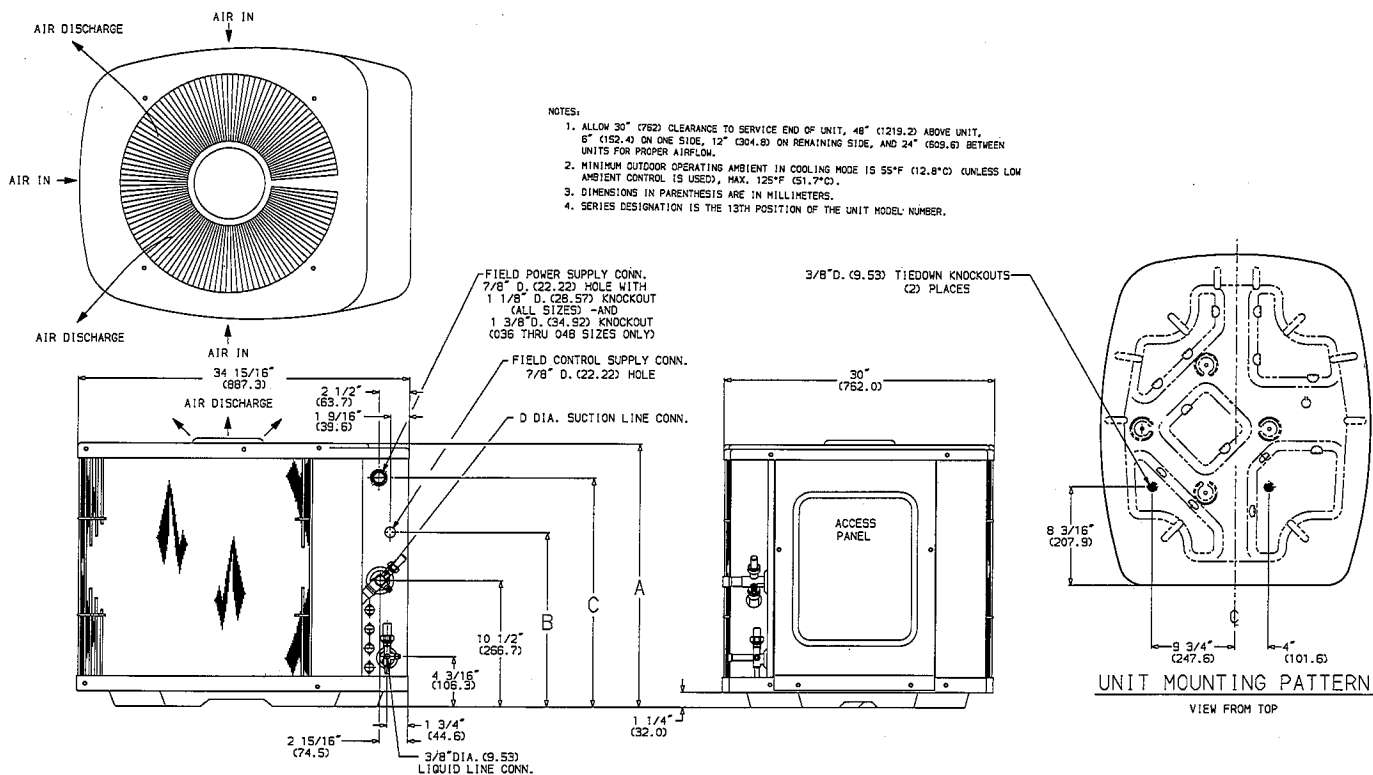

A91080

UNIT	A		B		C		D	
	In.	(mm)	In.	(mm)	In.	(mm)	In.	(mm)
024	25-7/8	657.2	15-1/2	393.7	21-7/8	555.6	5/8	15.88
030	25-7/8	657.2	15-1/2	393.7	21-7/8	555.6	3/4	19.05
036	31-7/8	809.6	21-1/2	546.1	27-7/8	708.0	3/4	19.05
042,060	37-7/8	962.0	27-1/2	698.5	33-7/8	860.4	7/8	22.22
048	31-7/8	809.6	21-1/2	546.1	27-7/8	708.0	7/8	22.22

Fig. 2—Unit Reference Drawing

CAUTION

If unit is to be installed on system with a thermostatic expansion valve (TXV), removal of the indoor coil piston is required.

Step 4—Make Piping Connections

Outdoor units may be connected to indoor sections using accessory tubing package or field-supplied tubing of refrigerant grade, correct size, and condition. The liquid- and vapor-tube diameters can be determined by using Table 1. For tubing requirements beyond 50 ft (15.24m), obtain information from your local distributor.

If required, install solenoid valve in liquid line to achieve desired rating. (See Fig. 3.)

CAUTION

DO NOT BURY MORE THAN 36 IN. (914mm) OF REFRIGERANT TUBING IN GROUND. If any section of tubing is buried, there must be a 6-in.(152mm) vertical rise to the valve connections on the outdoor unit. If more than the recommended length is buried, refrigerant may migrate to cooler buried section during extended periods of unit shut-down, causing refrigerant slugging and possible compressor damage at start-up.

CAUTION

For systems installed with a liquid-line solenoid valve, solenoid valve must be energized during evacuation and purging for effective evacuation.

If either refrigerant tubing or indoor coil is exposed to atmospheric conditions for longer than 5 minutes, it must be evacuated to 1000 microns to eliminate contamination and moisture in the system.

Run refrigerant tubes as directly as possible, avoiding unnecessary turns and bends. Suspend refrigerant tubes so they do not damage insulation on vapor tube and do not transmit vibration to structure. Also, when passing refrigerant tubes through wall, seal opening so vibration is not transmitted to structure. Leave slack in refrigerant tubes between structure and unit to absorb vibration.

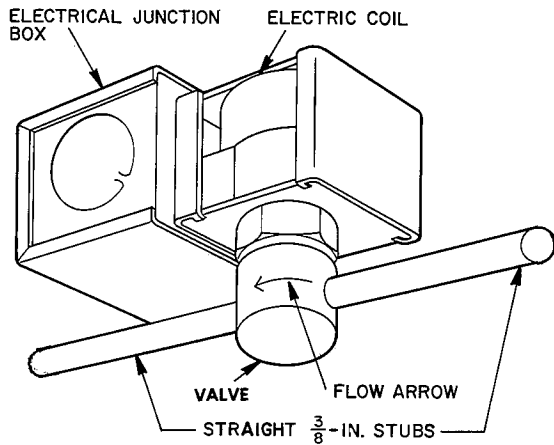

Fig. 3—Solenoid Valve Installation

A87044

Table 1—Refrigerant Connections and Recommended Liquid and Vapor Tube Diameters

UNIT SIZE	LIQUID		VAPOR	
	Conn. Dia.	Tube Dia.	Conn. Dia.	Tube Dia.
024	3/8	3/8	5/8	5/8
030, 036	3/8	3/8	3/4	3/4
042, 048	3/8	3/8	7/8	7/8
060	3/8	3/8	7/8	1-1/8

1. Tube diameters are for lengths up to 50 ft. For tube sets over 50 ft. consult Long-Line Application Guideline.
2. Do not apply cap-tube indoor coils to these units.

OUTDOOR UNITS CONNECTED TO FACTORY-APPROVED INDOOR UNITS

Outdoor units contain correct system refrigerant charge for operation with indoor unit of the same size when connected by 25 ft (7.62m) of field-supplied or factory accessory tubing. Check refrigerant charge for maximum efficiency (see Refrigerant Charging).

REFRIGERANT TUBING

Connect tubing to fittings on outdoor unit vapor and liquid service valves. (See Fig. 2.)

⚠ CAUTION

A brazing shield **MUST** be used when tubing sets are being brazed to the service valves to prevent damage to the painted unit surface.

⚠ CAUTION

To avoid valve damage while brazing, service valves must be wrapped with a heat-sinking material such as a wet cloth.

SWEAT CONNECTION

Use refrigerant grade tubing. Service valves are closed from factory and ready for brazing. After wrapping the service valve

with a wet cloth, the tubing set can be brazed to the service valve using either silver bearing or non-silver bearing brazing material. Consult local code requirements. Refrigerant tubing and indoor coil are now ready for leak testing. This check should include all field and factory joints.

Step 5—Make Electrical Connections

Be sure field wiring complies with local and national fire, safety and electrical codes, and voltage to system is within limits shown on unit rating plate. Contact local power company for correction of improper voltage. See unit rating plate for recommended circuit protection device.

NOTE: Operation of unit on improper line voltage constitutes abuse and could affect unit reliability. See unit rating plate. Do not install unit in system where voltage or phase imbalance may fluctuate above or below permissible limits.

NOTE: Use copper wire only between disconnect switch and unit.

DISCONNECT
PER N. E. C. AND/ OR
LOCAL CODES

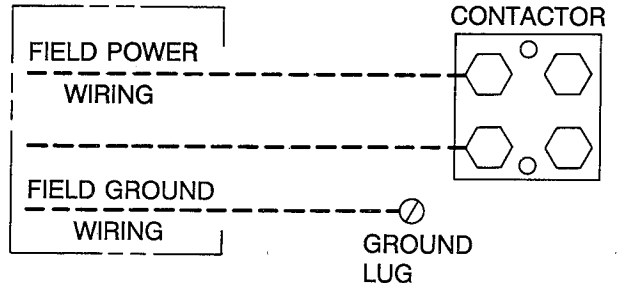

Fig. 4—Line Power Connections

A91056

⚠ WARNING

To avoid personal injury or death, do not supply power to unit with compressor terminal box cover removed.

BRANCH CIRCUIT DISCONNECT

Disconnect must be of adequate size to handle unit starting current, but not larger than maximum fuse size shown on unit rating plate. Locate disconnect within sight from and ready accessible from unit, per Section 440-14 of NEC.

⚠ WARNING

According to NEC, ANSI/NFPA 70, and local codes, the cabinet must have an uninterrupted or unbroken ground, to minimize personal injury if an electrical fault should occur. The ground may consist of electrical wire or metal conduit when installed in accordance with existing electrical codes. Failure to follow this warning could result in an electric shock, fire, or death.

ROUTE GROUND AND POWER WIRES

Remove access panel and control box cover to gain access to unit wiring. Extend wires from disconnect through power wiring hole provided (see Fig. 2) and into unit control box. Size wires per NEC, but not smaller than minimum wire size shown on unit rating plate.

CONNECT GROUND AND POWER WIRES

Connect ground wire to ground connection in control box for safety. Connect power wiring to contactor as shown in Fig. 4.

NOTE: Use No. 18 AWG color-coded, insulated (35 C min) wire. If thermostat is located more than 100 ft from unit as measured along the control voltage wires, use No. 16 AWG color-coded wires to avoid excessive voltage drop.

CONNECT CONTROL WIRING

Route 24-volt control wires through control wiring grommet and connect to brown and blue pigtailed supplied in unit splice box (Fig. 5.)

Use furnace or fan coil transformer as 24-volt supply for system as shown in Fig. 5, or use accessory transformer. Most systems require minimum 40 va, except 60 va is required for 048 and 060 size units or units installed with liquid line solenoid.

Step 6—Compressor Crankcase Heat

A crankcase heater is required if the refrigerant tubing is longer than 50 ft (15.24m).

Step 7—Install Electrical Accessories, if any

Refer to the individual instructions packaged with the kit or accessory when installing.

Step 8—Start-Up

1. When equipped with a crankcase heater, energize heater a minimum of 24 hours before starting unit. To energize heater only, set thermostat at OFF position and close electrical disconnect to outdoor unit.
2. Fully back seat (open) liquid and vapor tube service valves.
3. Unit is shipped with valve stem(s) front seated, and caps installed. Replace stem caps after system is opened to refrigerant flow (back seated). Replace caps finger-tight and tighten additional 1/6-turn with wrench.

4. Close electrical disconnects to energize system.
5. Set room thermostat at desired temperature. Be sure set point is below indoor ambient temperature.
6. Set room thermostat at COOL and fan switch at FAN or AUTO, as desired. Operate unit for 15 minutes. Check system refrigerant charge. See Refrigerant Charging.

Step 9—Checking Charge

Factory charge is shown on unit rating plate.

⚠ CAUTION

Do not vent refrigerant to atmosphere. Recover during system repair or final unit disposal.

⚠ WARNING

Service valve gage ports are not equipped with Schrader valves. To prevent personal injury, make sure gage manifold is connected to the valve gage ports before moving valves off fully back seated position. Wear safety glasses and glove when handling refrigerant.

⚠ CAUTION

Compressor damage may occur if system is overcharged.

Adjust charge by following procedure shown on Superheat Charging Tables located on unit information plate.

Step 10—Leave User's Manual with Homeowner

Explain system operation and maintenance procedures outlined in User's Manual.

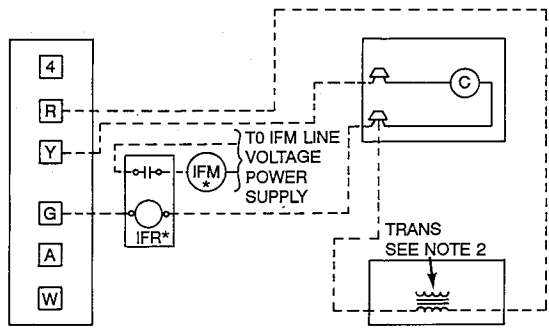

ARRANGEMENT A-(COOLING ONLY)

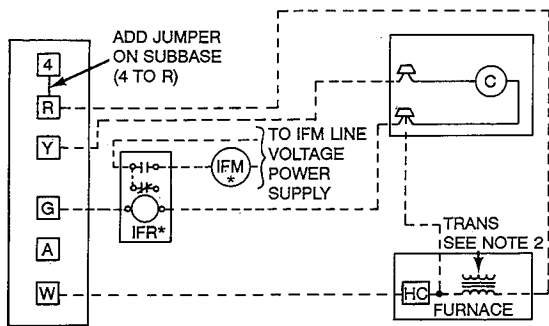

ARRANGEMENT B-ONE TRANSFORMER
(COOLING AND ONE-STAGE HEATING)

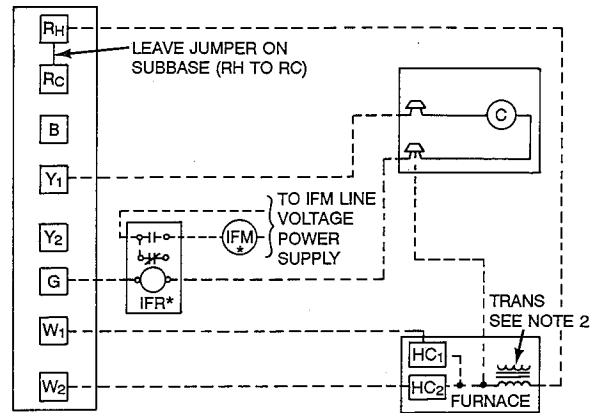

ARRANGEMENT C-ONE TRANSFORMER
(COOLING AND TWO-STAGE HEATING)

*IFR AND IFM ARE LOCATED IN FURNACE ON HEATING-COOLING APPLICATIONS. IF ACCESSORY IFR IS REQUIRED FOR COOLING-ONLY APPLICATIONS, LOCATE (IFR) IN FAN COIL.

C	-CONTACTOR		FIELD SPLICE
HC	-HEATING CONTROL		FIELD WIRING
IFM	-INDOOR FAN MOTOR		FACTORY WIRING
IFR	-INDOOR FAN RELAY		
TRANS	-TRANSFORMER		

NOTES: 1. REFER UTO UNIT WIRING LABEL FOR WIRE COLORS: C TO G AND C TO Y CONNECTIONS.
2. N.E.C. CLASS 2, 24V CIRCUIT, MIN. 40VA REQUIRED; 60VA REQUIRED FOR 050 AND 060 SIZE UNITS OR UNITS INSTALLED WITH LIQUID LINE SOLENOID VALVE.

Fig. 5—24-Volt Control Circuit Connections

A91058

Manufacturer reserves the right to discontinue, or change at any time, specifications or designs without notice and without incurring obligations.

Free Manuals Download Website

<http://myh66.com>

<http://usermanuals.us>

<http://www.somanuals.com>

<http://www.4manuals.cc>

<http://www.manual-lib.com>

<http://www.404manual.com>

<http://www.luxmanual.com>

<http://aubethermostatmanual.com>

Golf course search by state

<http://golfingnear.com>

Email search by domain

<http://emailbydomain.com>

Auto manuals search

<http://auto.somanuals.com>

TV manuals search

<http://tv.somanuals.com>