

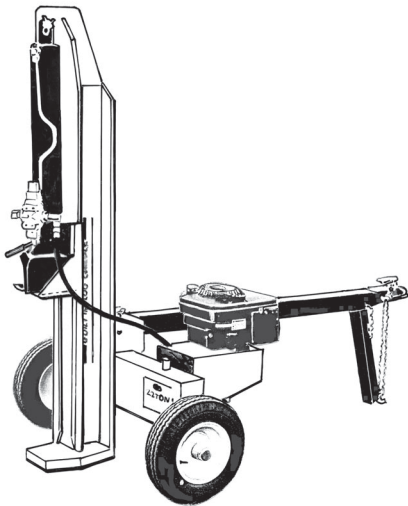

VERTICAL/HORIZONTAL LOG SPLITTERS

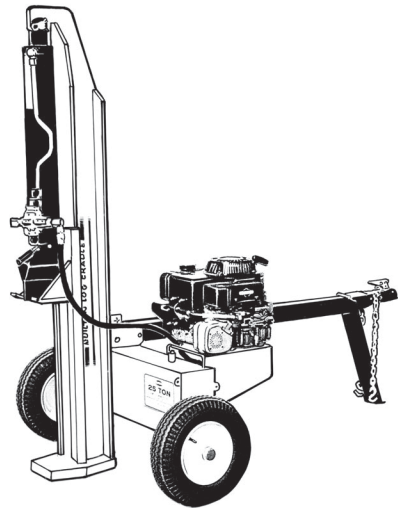

MODEL NO. LS401221
22 TON



MODEL NO. LS401216
25 TON

Owner's Manual

ASSEMBLY & OPERATING INSTRUCTIONS

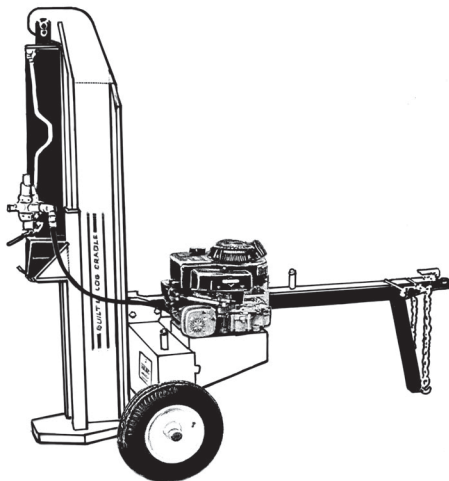

MODEL NO. LS401213
28 TON

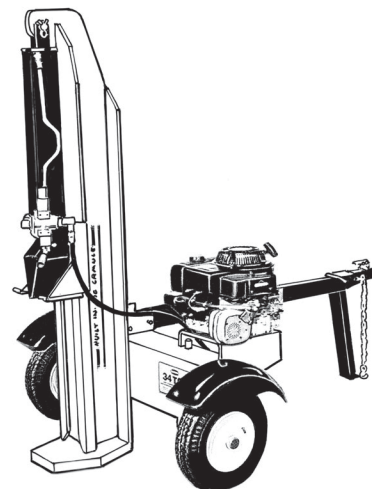

MODEL NO. LS401224
34 TON



This safety alert symbol identifies important safety messages in this manual. Failure to follow this important safety information may result in serious injury or death.

Table of Contents

| | Page(s) |
|---|------------|
| Important Safety Information..... | 1-6 |
| Intended Use | 1 |
| Personal Protective Equipment | 1 |
| Safety Decals | 1-2 |
| General Safety | 3 |
| Preparation of the Log | 3 |
| Work Area | 3 |
| Operation of the Log Splitter | 3-4 |
| Repair and Maintenance Safety | 4 |
| Hydraulic Safety | 5 |
| Fire Prevention | 5-6 |
| Towing Safety | 6 |
| Assembly Instructions | 7 |
| Operating Instructions | 7-9 |
| Engine Oil Recommendations | 8 |
| Starting Instructions | 8 |
| Towing | 9 |
| Operation | 9 |
| Maintenance | 9 |
| Parts List for Models LS401221, LS401213, LS401216 and LS401224 | 10-11 |
| Parts Breakdown Illustration | 12 |
| Notes | 13 |
| Specifications | Back Cover |



IMPORTANT SAFETY INFORMATION



WARNING: Read and thoroughly understand all instructions and safety information before assembling or operating this log splitter. Failure to do so may cause serious injury or death. Do not allow anyone to operate this log splitter who has not read this manual. As with all power equipment a log splitter can be dangerous if assembled or used improperly. Do not operate this log splitter if you have doubts or questions concerning safe operation. Call our customer service department at 1-800-525-8322 to address these concerns.

Si no entiende ingles, se prefiere que busque alguien que interprete las instrucciones para usted.

INTENDED USE

NEVER use this log splitter for any other purposes than splitting wood. It is designed for this use **only**. Any other use can cause serious injury or death.

PERSONAL PROTECTIVE EQUIPMENT



BEFORE operating this log splitter make sure that you wear safety gear such as goggles or safety glasses, steel toed shoes and tight fitting gloves (without loose cuffs or draw strings). Always wear a protective hearing device when operating this log splitter.

NEVER wear loose clothing or jewelry that can be caught by moving parts of the log splitter. Keep clothing and hair away from all moving parts when operating this log splitter.

SAFETY DECALS

Make sure that all safety warning decals are in good condition and readable. Always replace missing or defaced decals. Write us or call 1-800-525-8322 and they will be sent to you at no charge.

WARNING

- FAILURE TO FOLLOW THESE RULES CAN CAUSE TRAILER TO DETACH WHILE TOWING AND MAY RESULT IN SERIOUS INJURY OR DEATH.
- DO NOT EXCEED WEIGHT CAPACITY OF BALL OR LOAD LIMITS STAMPED ON COUPLER.
- ALWAYS USE SAFETY CHAINS WHEN TOWING.
- ALWAYS CHECK THAT THE COUPLER HANDLE IS LOCKED BEFORE TOWING.
- ALWAYS USE THE CORRECT BALL SIZE THAT IS STAMPED ON COUPLER.
- ALWAYS ADJUST COUPLER LOCKING PRESSURE ON BALL BEFORE USE.
- CHECK COUPLER TIGHTNESS BEFORE TOWING AND AFTER TOWING 50 MILES.
- ALWAYS CHECK COUPLER AND BALL FOR DAMAGE BEFORE TOWING. REPLACE IF DAMAGED.
- AVOID SHARP TURNS AND STEEP VERTICAL ANGLES WHEN TOWING TO PREVENT DAMAGE TO COUPLER OR ITS COMPONENTS.

OPERATING INSTRUCTIONS

- Before using, adjust coupler locking pressure on ball. Put handle in locked position with ball in coupler. Tighten locknut against tension spring so that coupler is firmly on ball. The proper adjustment allows handle to be released with moderate pressure.
- Pull up on coupler handle to open and place coupler over ball. When ball is seated in ball socket pull back on handle to locked position.
- Check to make sure the coupler is tight on the ball after towing for 50 miles. Always check for tightness before towing and make sure handle is in locked position.

PART NUMBER: DL52-2-9
LOCATION: TOP, FRONT END OF TONGUE

PART NUMBER: DL52-2-8
LOCATION: TOP, FRONT END OF TONGUE

CAUTION

VALVE ON FUEL LINE MUST BE IN THE **OFF** POSITION FOR TOWING.

PART NUMBER: DL52-2-10
LOCATION: BRIGGS & STRATTON ENGINES 8 H.P. AND UP



IMPORTANT SAFETY INFORMATION

WARNING

1. READ AND UNDERSTAND OPERATOR'S MANUAL THOROUGHLY BEFORE OPERATION. FAILURE TO DO SO MAY RESULT IN SERIOUS INJURY.
2. KEEP ALL SHIELDS IN PLACE.
3. KEEP HANDS, FEET AND CLOTHING AWAY FROM POWER-DRIVEN PARTS.
4. ALWAYS WEAR SAFETY GLASSES AND SAFETY SHOES DURING OPERATION.
5. ALWAYS OPERATE OUT-OF-DOORS WITH GOOD VENTILATION.
6. ALWAYS STOP ENGINE AND REMOVE SPARK PLUG WIRE BEFORE PERFORMING MAINTENANCE OPERATIONS.
7. ALWAYS SHUT OFF ENGINE WHEN LEAVING LOG SPLITTER UNATTENDED, EVEN FOR A SHORT PERIOD OF TIME.
8. ONLY ONE PERSON SHOULD LOAD AND OPERATE THE LOG SPLITTER. KEEP ALL OTHERS CLEAR DURING OPERATION. NEVER ALLOW ONE PERSON TO OPERATE VALVE WHILE ANOTHER IS POSITIONING THE LOG.
9. ALWAYS POSITION LOG WITH HANDS ON THE SIDES OF LOG. KEEP HANDS CLEAR OF ENDS.
10. KEEP ALL CHILDREN AWAY FROM THE LOG SPLITTER.
11. DO NOT STEP OVER THE LOG SPLITTER.
12. ONLY USE HANDS TO OPERATE THE CONTROL VALVE.
13. DO NOT OPERATE THE LOG SPLITTER WHILE UNDER THE INFLUENCE OF ALCOHOL, DRUGS OR MEDICATION.
14. ALWAYS OPERATE THE LOG SPLITTER ON LEVEL, DRY, NON-SLIPPERY SURFACES. KEEP OFF SLOPES.
15. KEEP WORK AREA CLEAR OF SPLIT WOOD, DEBRIS OR OTHER OBSTACLES.
16. ALWAYS STAY IN THE OPERATOR ZONE WHEN USING THE LOG SPLITTER.
17. ALWAYS SPLIT WOOD IN THE DIRECTION OF THE GRAIN ONLY.
18. DO NOT ADD GASOLINE WHILE THE ENGINE IS HOT OR RUNNING. ALLOW ALL SPILLED GAS TO EVAPORATE BEFORE USING LOG SPLITTER.

PART NUMBER: DL51-1-32
LOCATION: TOP OF HYDRAULIC CYLINDER



PART NUMBER: DL51-1-57
LOCATION: TOP, FORWARD SECTION
OF HYDRAULIC CYLINDER

CAUTION

USE EXTREME CARE WHEN TILTING THE BEAM. DUE TO THE HEAVY WEIGHT OF THE BEAM, SOME ASSISTANCE MAY BE NEEDED TO INSURE SAFETY AND PREVENT INJURY.

PART NUMBER: DL51-1-86
LOCATION: CLEVIS END OF BEAM
NEAR TILT LOCKING PIN
28 TON AND 34 TON MODELS ONLY

 **WARNING**

TO PREVENT SERIOUS INJURY OR DEATH AND/OR EQUIPMENT DAMAGE

Do not exceed 45 mph when towing this log splitter. Loss of control could result at high speed.

DL52-2-14

PART NUMBER: DL52-2-14
LOCATION: TOP, FRONT END OF TONGUE



IMPORTANT SAFETY INFORMATION

GENERAL SAFETY

Failure to follow these instructions may result in serious injury or death.

NEVER allow children or adults lacking proper instructions and understanding to operate this log splitter.

KEEP all people and pets a minimum of 10 feet away from your work area when operating this log splitter. Only the operator is to be near the log splitter during use.

If a helper is assisting in loading logs, **NEVER** actuate the control until the helper is clear of the work area.

NEVER operate the log splitter when under the influence of alcohol, drugs or medication.

NEVER allow a person who is tired or otherwise not alert to use your log splitter.

PREPARATION OF THE LOG

Both ends of the log should be cut as square as possible to help prevent the log from riding out of the splitter during operation. Do not split logs greater than 26 in. in length.

WORK AREA

NEVER operate the log splitter on slippery, wet, muddy or icy ground.

ONLY operate your log splitter on level ground. Operating on a slope could cause the log splitter to roll over or logs to fall off.

NEVER operate your log splitter in an enclosed area. Exhaust fumes contain carbon monoxide which can be deadly when inhaled.

NEVER attempt to move your log splitter over hilly or uneven terrain without a tow vehicle or adequate help.

ALWAYS block the wheels to prevent movement of the log splitter while in operation.

ONLY operate your log splitter in daylight or under good artificial light.

ALWAYS keep the work area clean. Remove split wood around your log splitter immediately so that you don't stumble over it.

OPERATION OF THE LOG SPLITTER

ONLY operate the log splitter from the operator zone.

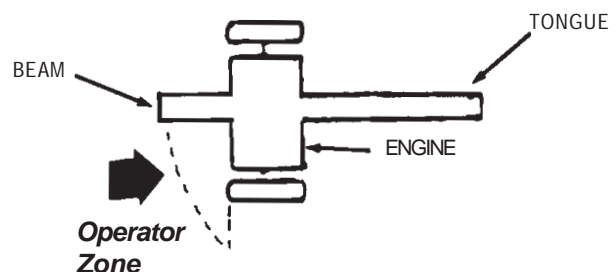



IMPORTANT SAFETY INFORMATION

KNOW how to stop the log splitter and disengage the controls before operating it.

NEVER place hands or feet between the log and splitting wedge during forward or reverse stroke. Serious injury or death could result.

NEVER straddle or step over the log splitter during operation.

NEVER reach or bend over the log splitter to pick up a log.

NEVER try to split two logs on top of each other.

NEVER try to cross split a second log.

NEVER allow one person to operate the valve while another is positioning the log.

NEVER attempt to load your log splitter when the ram or wedge is in motion.

ALWAYS use your hand to operate the control lever on the valve. **NEVER** use your foot, a rope or any extension device.

NEVER move the log splitter while the engine is running. Shut off the engine even if you are leaving the log splitter for a short period of time.

ALWAYS avoid contact with the muffler and other hot areas of the engine during operation to prevent burns.

REPAIR AND MAINTENANCE SAFETY

NEVER operate your log splitter when it is in poor mechanical condition or in need of repair.

Periodically check that all nuts, bolts, screws, hydraulic fittings and hose clamps are tightened.

NEVER alter your log splitter in any manner such as adding a rope or extension to the control lever or adding to the width or height of the wedge. Such alterations may cause your log splitter to be unsafe and will void the warranty.

Perform all recommended maintenance procedures before using your log splitter.

Replace all damaged or worn parts immediately.

NEVER tamper with the engine to run it at excessive speeds. The maximum engine speed is preset by the manufacturer and is within safety limits.

ALWAYS remove the spark plug wire before performing any service or repair on your log splitter.

ALWAYS check the level of hydraulic oil and engine oil before operation.

ALL replacement parts must meet manufacturer's specifications.



IMPORTANT SAFETY INFORMATION

HYDRAULIC SAFETY

The hydraulic system of your log splitter requires careful inspection along with the mechanical parts. Be sure to replace frayed, kinked, cracked or otherwise damaged hydraulic hose and components.

NEVER check for leaks of hydraulic fluid with your hand. Fluid escaping from a small hole can be almost invisible. Escaping fluid under pressure can have sufficient force to penetrate skin causing serious personal injury or even death. Leaks can be detected by passing a piece of cardboard over the suspected leak and looking for discoloration.

ALWAYS seek professional medical attention immediately if injured by escaping hydraulic fluid. Serious infection or reaction can develop if proper medical treatment is not administered immediately.

ALWAYS be sure to relieve all pressure by shutting off the engine and moving the valve control handle back and forth should it become necessary to loosen or remove any hydraulic fitting.

NEVER remove the cap from the hydraulic tank or reservoir while the log splitter is running. Hot oil under pressure could result in serious injury.

NEVER adjust the hydraulic valve. The pressure relief valve on your log splitter is preset at the factory. Only a qualified service technician should perform this adjustment.

FIRE PREVENTION

NEVER operate your log splitter near a flame or spark. Hydraulic oil and gasoline are flammable and can explode.

NEVER fill the gas tank while the engine is hot or running. Allow the engine to cool before refueling.

NEVER smoke while operating or refueling your log splitter. Gas fumes can easily explode.

ONLY refuel your log splitter in a clear area with no gas fumes or spilled gas.

ALWAYS use an approved fuel container.

ALWAYS replace the gas cap securely.

If gasoline has spilled, move the log splitter away from the area of the spill and avoid creating any source of ignition until the spilled gas has evaporated.

ALWAYS take a Class B fire extinguisher with you when operating this log splitter in dry areas as a precautionary measure against possible flying sparks.

ALWAYS drain the fuel tank prior to storage to avoid the potential fire hazard.

ALWAYS store gasoline in an approved, tightly sealed container. Store the container in a cool, dry place.

NEVER store gasoline in the house or near a heating appliance.



IMPORTANT SAFETY INFORMATION

IMPORTANT NOTE:

This log splitter is equipped with an internal combustion engine and should not be used on or near any unimproved forest-covered, brush-covered or grass-covered land unless the engine's exhaust system is equipped with a spark arrester meeting applicable local or state laws (if any). If a spark arrester is used, it should be maintained in effective working order by the operator. In the state of California a spark arrester is required by law. Other states have similar laws. Federal laws apply on federal lands. A spark arrester muffler (optional by manufacturer) is available as an accessory at your nearest engine dealer. Always check the legal requirements in your area.

TOWING SAFETY

ALWAYS check all local and state regulations regarding towing, licensing, and lights before towing your log splitter.

ALWAYS check before towing to make sure that the log splitter is correctly and securely attached to the towing vehicle and that the safety chains are secured to the hitch or bumper of the vehicle with enough slack to allow turning. Always use a Class I, 2" ball with this log splitter.

NEVER carry any cargo or wood on your log splitter.

NEVER allow anyone to sit or ride on your log splitter.

ALWAYS disconnect your log splitter from the towing vehicle before operating it.

ALWAYS be careful when backing up with your log splitter in tow. It could jackknife.

ALWAYS allow for added length of your log splitter when turning, parking, crossing intersections and in all driving situations.

NEVER exceed 45 mph when towing your log splitter. Towing the log splitter at speeds higher than 45 mph could result in loss of control, damage to the equipment, serious injury or death. Adjust towing speed for terrain and conditions. Be extra cautious when towing over rough terrain especially railroad crossings.

ASSEMBLY INSTRUCTIONS

NOTE: The following instructions pertain to four SpeeCo log splitters, the 22 ton (LS401221), 25 ton (LS401216), 28 ton (LS401213) and the 34 ton (LS401224). The four models share most of the component parts. Any differences are noted in the parts list and assembly instructions.

NOTE: This log splitter was partially assembled at the factory. Refer to the drawing and parts list should it become necessary to disassemble the unit for repair or replacement of parts.

STEP 1: Remove all the components from the crate. Inspect each piece for shipping damage. If any part is damaged, contact your dealer or delivering carrier.

STEP 2: Attach the tongue (3) to the tank/axle (2) as shown in the diagram using the two 1/2 in. NC x 4-1/2 in. hex cap screws (48), 1/2 in. lockwashers (47) and 1/2 in. NC hex nuts (46) from the hardware kit. Tighten. Make sure the ground stand (24) is in the vertical position.
NOTE: Flatwashers are included in the hardware kit should it be necessary to use them as spacers. This will eliminate play between the tongue and the tank/tongue mounting plate.

STEP 3: Remove the rubber covering from the two spindles on the tank/axle (2). The wheel bearing cups, bearing cones, grease seals and hub caps are already assembled. Bearing cones have been greased at the factory. Remove the blue, plastic protective covering from the wheel hubs. Mount the wheels (54) to the spindles on the tank/axle (2) using the 3/4 in. light flatwasher (59) and 3/4 in. slotted nut (60) from the hardware kit. There are two types of light flatwashers (59). Use the ones that best allow the wheel to rotate freely after the 3/4 in. slotted nut (60) is tightened down and bearing play is removed. Install the cotter pin (61) and the hub cap (62) from the hardware kit. Repeat step 4 for the other wheel.

STEP 4: Stand the beam (1) up on end. **NOTE:** At least two people are required to raise the beam for the 28 ton and 34 ton models to insure safety and prevent injury. Make sure that the beam is stable. Remove the pivot pin (52) and the clip pin (53) from the tank/axle (2). Roll the axle/tongue assembly into position between the two tabs on the beam (1). Slide the pivot pin (52) through the holes and lock in place with the clip pin (53).

STEP 5: Connect the end of the 1/2 in. I.D. x 44 in. (28 & 34 ton models) or 1/2 in. I.D. x 42 in. (22 & 25 ton models) hydraulic hose (21) coming from the fitting (20) on the pump (9) to the fitting (75) on the valve (5).

STEP 6: Slide one hose clamp (50) on the end of the 3/4 in. I.D. x 37 in. (28 ton and 34 ton models) or 3/4 in. I.D. x 32-1/2 in. (22 & 25 ton models) hydraulic hose (49) that comes from the fitting on the tank/axle (2). Then connect the hose to the fitting (69) on the valve (5). Tighten the hose clamp.

STEP 7: If the optional fender kit (standard on the 34 ton model) was purchased, attach the fenders (44) to the tank/axle (2) using the 1/4 in. NC x 3/4 in. hex cap screws (43), 1/4 in. flatwashers (42), 1/4 in. lockwashers (41) and 1/4 in. hex nuts (40). Tighten.

OPERATING INSTRUCTIONS



WARNING: Read and thoroughly understand all instructions and safety information before operating this log splitter. Failure to do so may cause serious injury or death. Do not allow anyone to operate this log splitter who has not read this manual. As with all power equipment a log splitter can be dangerous if it is assembled or used improperly. Do not operate this log splitter if you have doubts or questions concerning safe operation. Call our customer service department at 1-800-525-8322 to address these concerns.

Si no entiende ingles, se prefiere que busque alguien que interprete las instrucciones para usted.

IMPORTANT: The engine and hydraulic tank are shipped without oil. See the engine operating and maintenance instructions manual packed with your log splitter for the type of crankcase oil, fuel, etc. The engine manufacturer recommends lead-free gasoline only.



CAUTION: DO NOT START OR RUN THE ENGINE WITHOUT OIL IN THE HYDRAULIC RESERVOIR AND ENGINE.

STEP 2: The hydraulic reservoir should be filled with an SAE 20 hydraulic oil. If hydraulic oil is difficult to obtain, automatic transmission fluid can be substituted and should be used instead of hydraulic oil when temperatures are below 32 degrees F. Use only clean oil and take care to prevent dirt from entering the hydraulic reservoir.



CAUTION: *WHEN TIGHTENING THE BREATHER CAP ON THE TANK, POINT THE HOLE AWAY FROM THE ENGINE AND THE OPERATOR ZONE.*

ENGINE OIL RECOMMENDATIONS

- 1) **25 Ton, 28 Ton and 34 Ton Models-** For temperatures above 40 degrees F use an SAE 30W oil. Using multigrade oil may increase oil consumption. Using SAE 30W oil below 40 degrees F will result in hard starting and possible engine bore damage. For temperatures below 40 degrees F use an SAE 10W-30 or SAE 5W-30 oil. Oil capacity is about 1-1/2 quarts (48 ounces; 1.4 liters).
- 2) **22 Ton Model-** For temperatures above 40 degrees F use an SAE 30W oil. Using multigrade oils may increase oil consumption. Using SAE 30W oil below 40 degrees F will result in hard starting and possible engine bore damage. For temperatures below 40 degrees F use an SAE 10W-30 or SAE 5W-30 oil. Oil capacity is approximately 5/8 quart (20 ounces; 0.6 liter).

DIRECTIONS FOR FILLING HYDRAULIC SYSTEM

Fill the hydraulic reservoir with at least five gallons of hydraulic fluid (25 ton, 28 ton & 34 ton models). Use at least four gallons for the 22 ton model. After the hydraulic reservoir and the engine crankcase are filled with oil, start the engine. The hydraulic pump should prime itself. With the engine running, move the hydraulic valve lever toward the wedge. This will cause the cylinder to extend and expel air. When the cylinder is fully extended, retract it. Repeat this procedure several times. An erratic movement of the cylinder indicates that there is still air in the system. More oil should then be added to bring the fluid level up to the "OK" range on the dipstick. Total hydraulic capacities are as follows: 25, 28 and 34 ton models-31 quarts; 22 ton model-20 quarts. **NOTE:** If the tank is overfilled, it will tend to expel oil from the breather cap when the cylinder is retracted. After adding more oil to the tank, cycle the cylinder again until it has a constant speed indicating that all air has been expelled. Check the oil level in the reservoir again with the dipstick to make sure it is in the "OK" range. Do not fill beyond the "OK" range on the dipstick.

STARTING INSTRUCTIONS

Refer also to the Engine Operating and Maintenance Instructions manual for your particular log splitter.

1) 25 Ton, 28 Ton and 34 Ton Models with 10.5 h.p. Engine

- a) Move the throttle lever to "FAST". Always operate the engine with throttle lever in the "FAST" position
- b) Move choke control lever to "CHOKE" position.
- c) Grasp rope handle and pull slowly until resistance is felt. Then pull rapidly to start engine and avoid engine kickback.
- d) Allow the engine to warm up. If operating in warm weather, move the choke control lever toward "RUN" a short distance at a time over several seconds. For cold weather operation do this procedure over several minutes. Operate with choke lever in the "RUN" position.
- e) To stop engine, move the throttle lever to the "STOP" position.

2) 22 Ton Model with 6.5 h.p. Engine and Primer

- a) Move control lever to "FAST."
- b) Push primer bulb three (3) times.

NOTE: DO NOT USE PRIMER TO RESTART A WARM ENGINE AFTER A SHORT SHUTDOWN.

- c) Grasp starter handle and pull rope out slowly until resistance is felt. Then pull rope rapidly with full arm stroke. Let rope return to starter slowly.
- d) When engine starts, leave the control lever at "FAST." The throttle must be in the "FAST" position for maximum performance.

STEP 3: The engine maximum governed speed is preset at the factory at 3600 RPM no load speed. When splitting wood, the throttle should be set at the maximum setting to develop the horsepower required for the pump.

STEP 4: TOWING

The log splitter is equipped with pneumatic tires, a Class I coupler (2 in. diameter ball required) and safety chains. Before towing, the safety chains must be secured to the hitch or bumper of the vehicle. Local regulations should be checked regarding licensing, lights, towing, etc. See also Towing Safety on page 6 of this manual.

STEP 5: OPERATION



WARNING: See safety information related to operation of the log splitter on page 3 and 4 of this manual. Make sure that you have the recommended personal protective equipment described on page 1.

- 1) Set up the log splitter in a clear, level area and block the wheels. Make sure that the suction port on the tanks is always on the lower side of the log splitter.
- 2) Place a log on the beam against the foot plate. Make sure that the log is securely on the foot plate and up against the beam.
- 3) Depress the valve handle so that the cylinder will drive the wedge into the log. Extend the cylinder until the log splits or to the end of its stroke. If the log has not completely split after the cylinder has reached the end of its extension, retract the cylinder.
IMPORTANT: Leaving the valve in the "actuate" position at the end of the stroke may damage the pump. Always use extra care when splitting logs with unsquare ends.

NOTE: For operation in wooded areas, obtain a spark arrestor for the exhaust system. See the engine operating and maintenance manual and check with your authorized Briggs & Stratton service center. See also Fire Prevention on page 5 and 6 of this manual.

IMPORTANT: TO EXTEND THE LIFE OF THE HYDRAULIC CYLINDER, AVOID "BOTTOMING OUT" WEDGE PLATE TO THE FOOT PIECE. TO CONFORM WITH INDUSTRY SAFETY RECOMMENDATIONS, THE WEDGE STOPS 2 INCHES FROM THE END OF THE STROKE.

MAINTENANCE

- 1) Consult the operating and maintenance instructions of the engine manufacturer for engine care and maintenance.
- 2) Always check the oil level of the hydraulic reservoir before operation. Operating the log splitter without an adequate oil supply will cause severe damage to the pump.
- 3) Change the oil filter after the first 25 hours of operation. Thereafter, change the oil filter every 100 hours or seasonally, whichever comes first.
- 4) If the wedge becomes dull or nicked, it can be removed and sharpened. Remove the 1/2 in. diameter bolt that connects the wedge to the cylinder. The hose from the valve may need to be removed. While the log splitter is in the horizontal position, loosen the hose clamp and disconnect the hose from the valve. Carefully lift the cylinder to allow the wedge to slide forward. The wedge can now be lifted off and sharpened.
- 5) Clean the breather cap after 25 hours of operation. Clean it more often when operated in dusty conditions. To clean, remove the breather from the tank and flush with kerosene or liquid detergent to remove the dirt.
- 6) See also Repair and Maintenance Safety on page 4 of this manual.
- 7) All replacement parts must meet manufacturer's specifications.

PARTS BREAKDOWN FOR LS401221, LS401216, LS401213 AND LS401224 LOG SPLITTERS

| REFERENCE NO. | PART NO. | DESCRIPTION | NUMBER REQUIRED |
|---------------|-----------|--|-----------------|
| | LS401224 | 34 Ton Vertical/Horizontal Log Splitter Complete | |
| | LS401213 | 28 Ton Vertical/Horizontal Log Splitter Complete | |
| | LS401216 | 25 Ton Vertical/Horizontal Log Splitter Complete | |
| | LS401221 | 22 Ton Vertical/Horizontal Log Splitter Complete | |
| 1 | LS401148 | Beam (6-1/2" x 8") for 28 Ton and 34 Ton Models | 1 |
| | LS401182 | Beam (6" x 6") for 22 Ton and 25 Ton Models | 1 |
| 2 | LS401190 | Tank/Axle for 25 Ton, 28 Ton and 34 Ton Models | 1 |
| | LS401193 | Tank/Axle for 22 Ton Model | 1 |
| 3 | LS401261 | Tongue | 1 |
| 4 | HC390117 | 5" x 24" Hydraulic Cylinder for 34 Ton Model | 1 |
| | HC390119 | 4-1/2" x 24" Hydraulic Cylinder for 25 Ton and 28 Ton Models | 1 |
| | HC390118 | 4" x 24" Hydraulic Cylinder for 22 Ton Model | 1 |
| 5 | HC390406S | Auto-Return Valve for 22 Ton, 28 Ton and 34 Ton Models | 1 |
| | HC390406A | Auto-Return Valve for 25 Ton Model | 1 |
| 6 | LS401183 | Wedge for 28 Ton and 34 Ton Models | 1 |
| | LS401136 | Wedge for 22 Ton and 25 Ton Models | 1 |
| 7 | HC390524 | 10.5 H.P. Industrial/Commercial Engine for 25 Ton, 28 Ton and 34 Ton Models | 1 |
| | HC390529 | 6.5 H.P. Engine for 22 Ton Model | 1 |
| 8 | HC390601 | Filter | 1 |
| | HC390601A | Filter Element (see list of equivalent filter elements on page 5) | 1 |
| | HC390601B | Filter Base | 1 |
| 9 | HC390709 | 16 gpm Pump for 25 Ton, 28 Ton and 34 Ton Models (Barnes) | 1 |
| | HC390705B | 11 gpm Pump for 22 Ton Model (Barnes) | 1 |
| 10 | LS400824L | Pump-Engine Coupler for 25 Ton, 28 Ton and 34 Ton Models (3 pieces) | 1 |
| | LS400825L | 1" I.D. Coupler Half for 25 Ton, 28 Ton and 34 Ton Models (engine side) | 1 |
| | LS400826L | 1/2" I.D. Coupler Half for 25 Ton, 28 Ton and 34 Ton Models (pump side) | 1 |
| | LS400827L | Coupler Spider for 25 Ton, 28 Ton and 34 Ton Models | 1 |
| | LS400837 | Pump-Engine Coupler for 22 Ton Model | 1 |
| | LS400833L | 1/2" I.D. Coupler Half for 22 Ton Model (pump side) | 1 |
| | LS400838L | 7/8" I.D. Coupler Half for 22 Ton Model (engine side) | 1 |
| | LS400834L | Coupler Spider for 22 Ton Model | 1 |
| 12 | O/L | 5/16" NC x 1" Hex Cap Screw | 4 |
| 14 | O/L | 5/16" NC Locknut | 4 |
| 16 | LS400343 | 1/4" Square Engine Key for 25 Ton, 28 Ton and 34 Ton Models | 1 |
| | LS400321 | 3/16" Square Engine Key for 22 Ton Model | 1 |
| 17 | O/L | 5/16" NC x 1-1/2" Hex Cap Screw for 25 Ton, 28 Ton and 34 Ton Models | 4 |
| | O/L | 5/16" NC x 1-1/2" Hex Cap Screw for 22 Ton Model | 2 |
| | O/L | 5/16" NC x 2-1/2" Hex Cap Screw for 22 Ton Model | 1 |
| 18 | HC390316 | Hose Clamp # 16 | 2 |
| 19 | HC390248 | 1" x 9" Suction Hose for 25 Ton, 28 Ton and 34 Ton Models | 1 |
| | HC390241 | 3/4" x 8" Suction Hose for 22 Ton Model | 1 |
| 20 | HC390341 | 1/2" x 90 Degree Street Elbow | 1 |
| 21 | HC390257 | 1/2" I.D. x 47" Hydraulic Pressure Hose for 25 Ton, 28 Ton and 34 Ton Models | 1 |
| | HC390239 | 1/2" I.D. x 42" Hydraulic Pressure Hose for 22 Ton Model | 1 |
| 22 | HC390320 | 3/4 NPT x 3/4" 90 Degree Hose Fitting | 1 |
| 23 | HC390349 | 3/4" x 2-1/2" Nipple | 1 |
| 24 | LS401260 | Ground Stand | 1 |
| 25 | P7958 | 5/16" Locking Pin for Ground Stand | 1 |
| 26 | HW172718 | M10 x 1.5 x 85mm Bolt | 1 |
| 27 | O/L | 5/8" Lockwasher | 2 |
| 28 | O/L | 5/8" NF Hex Nut | 2 |
| 29 | HW172803 | M10 x 1.5 Nut | 3 |
| 31 | P789 | 7/8" Diameter Pin with 5/8" NF Thread | 1 |
| 32 | P794 | 1/4" Lynch Pin | 1 |
| 33 | LS400346 | Hitch Coupler for 2" Ball | 1 |

| REFERENCE NO. | PART NO. | DESCRIPTION | NUMBER REQUIRED |
|---------------|-----------|--|-----------------|
| 34 | HW172908 | 10mm Washer | 6 |
| 35 | HW172717 | M10 x 1.5 x 115mm Bolt 3/8" NC x 1" Grade 5 Hex Cap Screw | 1 |
| 36 | HW172716 | M10 x 1.5 x 100mm Bolt | 1 |
| 37 | LS400323 | Safety Chain with "S" Hook | 1 |
| | LS400345 | 3/8" "S" Hook | 1 |
| 39 | O/L | 5/16" NC Locknut for 25 Ton, 28 Ton and 34 Ton Models | 4 |
| | O/L | 5/16" Locknut for 22 Ton Model | 3 |
| 40 | O/L | 1/4" NC Hex Nut for Fender (optional) | 4 |
| 41 | O/L | 1/4" Lockwasher for Fender (optional) | 4 |
| 42 | O/L | 1/4" Flatwasher for Fender (optional) | 4 |
| 43 | O/L | 1/4" NC x 3/4" Hex Cap Screw for Fender (optional) | 4 |
| 44 | LS401151 | Fender for 34 Ton Model (optional for all other models) | 2 |
| 45 | LS400429 | Breather Cap | 1 |
| 46 | O/L | 1/2" NC Hex Nut | 2 |
| 47 | O/L | 1/2" Lockwasher | 3 |
| 48 | O/L | 1/2" NC x 4-1/2" Hex Cap Screw | 2 |
| 49 | HC390249 | 3/4" I.D. x 37" Hydraulic Return Hose for 22 Ton, 28 Ton and 34 Ton Models | 1 |
| | HC390250 | 3/4" I.D. x 32-1/2" Hydraulic Return Hose for 25 Ton Model | 1 |
| 50 | HC390316 | Hose Clamp # 16 | 2 |
| 52 | P71022WC | 5/8" x 6-1/4" Pivot Pin | 1 |
| 53 | O/L | 1/8" "R" Clip Pin | 1 |
| 54 | LS400312B | Pregreased Wheel Assembly | 2 |
| 55 | BE22176 | Grease Seal | 2 |
| 56 | BE22175 | Bearing Cone | 4 |
| 57 | BE22174 | Bearing Cup | 4 |
| 58 | LS400312 | 4.80 x 8" Road-Speed Tire | 2 |
| 59 | O/L | 3/4" Light Flatwasher | 2 |
| 60 | HN17120 | 3/4" NF Slotted Nut | 2 |
| 61 | O/L | 1/8" x 1-1/2" Cotter Pin | 2 |
| 62 | LS400332 | Hub Cap | 2 |
| 63 | O/L | 1/2" x 3-1/2" Grade 5 Hex Cap Screw for 28 Ton and 34 Ton Models | 1 |
| | O/L | 1/2" x 3" Grade 5 Hex Cap Screw for 22 Ton and 25 Ton Models | 1 |
| 64 | P7910 | Clip Pin | 2 |
| 65 | P7731A | Cylinder Pin | 1 |
| 66 | FW17316 | Flatwasher | 1 |
| 67 | HC390347 | Tube Fitting | 2 |
| 68 | HC390346 | 1/2" Diameter Steel Tube | 1 |
| 69 | HC390320 | 3/4 NPT x 3/4" 90 Degree Fitting | 1 |
| 70 | HC390343 | 1/2"-1/2" Hex Nipple | 1 |
| 71 | HC390311 | 3/4"-1/2" Reducer Bushing | 1 |
| 72 | HC390429A | Handle (valve) | 1 |
| | HC390434 | Chain Link for Valve Handle | 1 |
| | HC390435 | Valve Handle Mounting Bracket | 1 |
| 73 | O/L | 1/2" NC Hex Nut | 1 |
| 74 | LS401174 | 1-1/4" I.D. Grommet | 1 |
| 75 | HC390302 | Swivel Elbow 90 Degree | 1 |
| | LS401156 | Hardware Kit for 28 Ton and 34 Ton Models | 1 |
| | LS401155 | Hardware Kit for 22 Ton and 25 Ton Models | 1 |

O/L- Obtain locally. Common fasteners available through hardware and farm stores.

Replacement filter cartridge HC390601 interchanges with:

FRAM 1653A
NAPA 1553
Cross # 1A9023
Baldwin # BT839
Wicks # 51553

Repair Kits

HC390120F "O" Ring Kit for 4" x 24" Cylinder HC390118
HC390171 "O" Ring Kit for 4-1/2" x 24" Cylinder HC390119
HC390126 "O" Ring Kit for 5" x 24" Cylinder HC390117
HC390423 "O" Ring Kit for Valves HC390406A and HC390406S
HC390720B "O" Ring Kit for Pumps HC390705B and HC390709

LS401221, LS401216, LS401213 and LS401224 Log Splitters

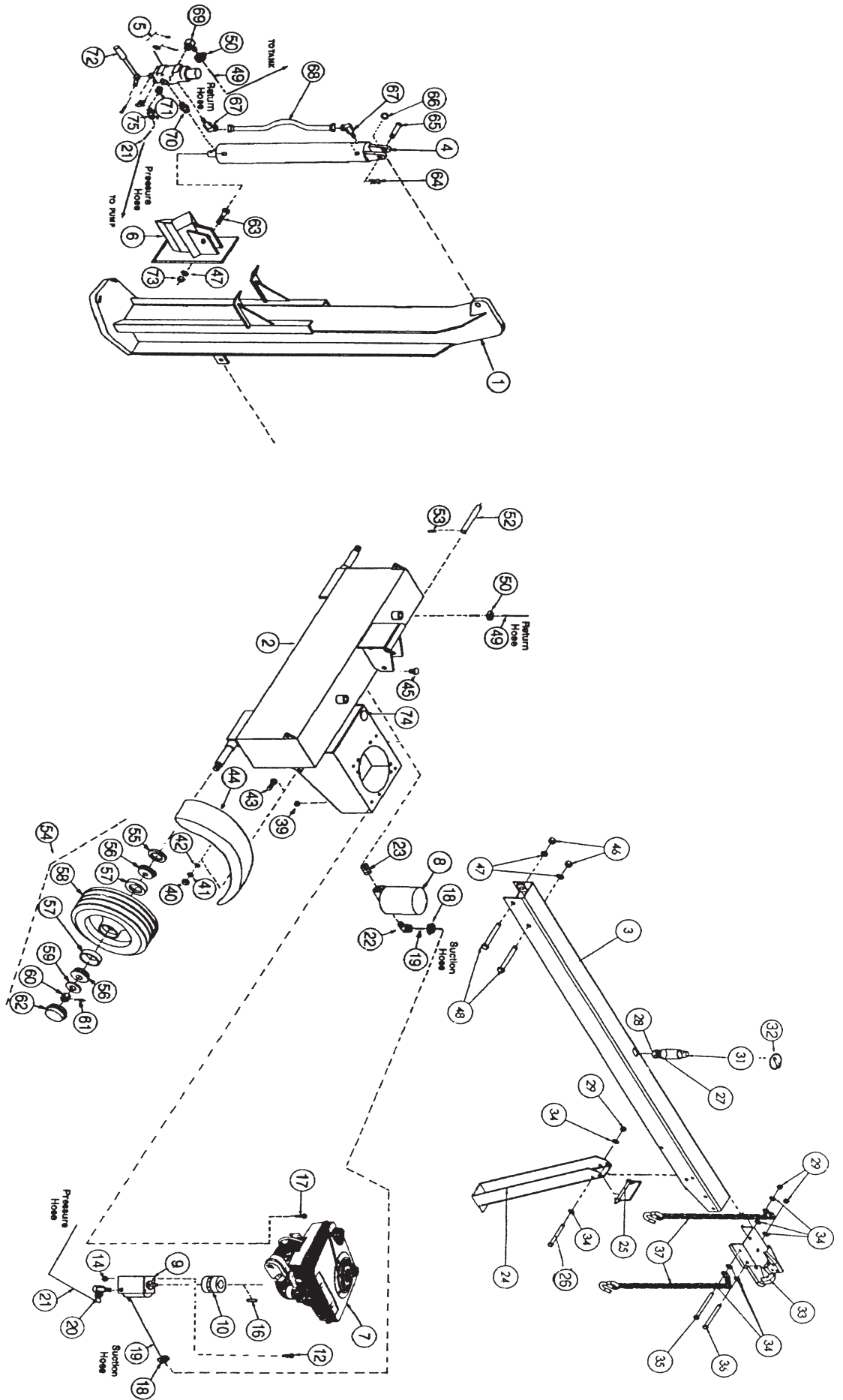

== NOTES ==

Model No. _____

Serial No. _____

Date of Purchase _____

Place of Purchase _____

SPECIFICATIONS

| | MODEL NO. LS401221 | MODEL NO. LS401216 | MODEL NO. LS401213 | MODEL NO. LS401224 |
|--------------------------|--|--|--|--|
| MAXIMUM SPLITTING FORCE | 22 Tons | 25 Tons | 28 Tons | 34 Tons |
| ENGINE | 6.5 H.P. Briggs & Stratton | 10.5 H.P. Briggs & Stratton Industrial/Commercial | 10.5 H.P. Briggs & Stratton Industrial/Commercial | 10.5 H.P. Briggs & Stratton Industrial/Commercial |
| CYLINDER | 4" Diameter X 24" Stroke | 4-1/2" Diameter X 24" Stroke | 4-1/2" Diameter X 24" Stroke | 5" Diameter X 24" Stroke |
| VALVE | Auto-Return | Auto-Return | Auto-Return | Auto-Return |
| PUMP | Two-Stage 11 gpm | Two-Stage 16 gpm | Two-Stage 16 gpm | Two-Stage 16 gpm |
| MAXIMUM LOG LENGTH | 26" | 26" | 26" | 26" |
| CYCLE TIME* | 14 Seconds | 12 Seconds | 12 Seconds | 15 Seconds |
| TIRES | 4.80 X 8" Pneumatic | 4.80 x 8" Pneumatic | 4.80 X 8" Pneumatic | 4.80 X 8" Pneumatic |
| WEDGE | 7" High with Spreader Wings | 7" High with Spreader Wings | 8" High with Spreader Wings | 8" High with Spreader Wings |
| BEAM SIZE | 6" X 6" | 6" X 6" | 6-1/2" X 8" | 6-1/2" X 8" |
| TOTAL HYDRAULIC CAPACITY | 17 Quarts | 31 Quarts | 31 Quarts | 31 Quarts |
| FILTER | Spin-On Replaceable | Spin-On Replaceable | Spin-On Replaceable | Spin-On Replaceable |
| HEIGHT | 72" in Vertical Position 42" in Horizontal Position | 72" in Vertical Position 42" in Horizontal Position | 72" in Vertical Position 42" in Horizontal Position | 72" in Vertical Position 42" in Horizontal Position |
| LENGTH | 78" | 78" | 78" | 78" |
| WIDTH | 49" | 49" | 49" | 49" |
| SHIPPING WEIGHT | 525 lbs. | 592 lbs. | 655 lbs. | 675 lbs. |

* Ideal case cycle times. Actual cycle times will vary depending on temperature, altitude, engine speed, pump efficiency, etc.

SPECIAL  PRODUCTS
 15000 W. 44TH AVE. GOLDEN, CO 80403-1824 • 303-279-5544
 TOLL FREE U.S.A. NO. 800-525-8322 • FAX 303-278-3432

Free Manuals Download Website

<http://myh66.com>

<http://usermanuals.us>

<http://www.somanuals.com>

<http://www.4manuals.cc>

<http://www.manual-lib.com>

<http://www.404manual.com>

<http://www.luxmanual.com>

<http://aubethermostatmanual.com>

Golf course search by state

<http://golfingnear.com>

Email search by domain

<http://emailbydomain.com>

Auto manuals search

<http://auto.somanuals.com>

TV manuals search

<http://tv.somanuals.com>