



# Catalyst 6500 Series Switch and Cisco 7600 Series Router CMM Installation and Verification Note

---

## Product Number: WS-SVC-CMM

This publication contains the procedures for installing and configuring the Catalyst 6500 series switch and Cisco 7600 series router Communication Media Module (CMM). Installation and configuration procedures are provided for the following CMM port adapters:

- 6-port T1 port adapter (WS-SVC-CMM-6T1)
- 6-port E1 port adapter (WS-SVC-CMM-6E1)
- 24-port FXS port adapter (WS-SVC-CMM-24FXS)
- 128-port ad-hoc conferencing and transcoding (ACT) port adapter (WS-SVC-CMM-ACT)



### Note

Except where specifically differentiated, the term “Catalyst 6500 series switches” includes both Catalyst 6500 series switches and Catalyst 6000 series switches.

---



### Note

Throughout this publication, except where specifically differentiated, the term *supervisor engine* refers to Supervisor Engine 1, Supervisor Engine 2, and Supervisor Engine 720. Additionally, the term *Multilayer Switch Feature Card (MSFC)* refers to MSFC, MSFC2, and MSFC3.

---



Corporate Headquarters:  
Cisco Systems, Inc., 170 West Tasman Drive, San Jose, CA 95134-1706 USA

Copyright © 2001–2005 Cisco Systems, Inc. All rights reserved.

# Contents

This publication contains these sections:

- [Front Panel Descriptions, page 2](#)
- [Requirements, page 6](#)
- [Safety Overview, page 7](#)
- [Required Tools, page 9](#)
- [Installing and Removing the CMM, page 9](#)
- [Removing and Replacing Port Adapters, page 18](#)
- [Verifying the Installation, page 24](#)
- [RJ-45 Port Connector and Cabling Specifications, page 24](#)
- [RJ-21 Port Connector and Cabling Specifications, page 26](#)
- [Accessing the Port Adapter Ports, page 27](#)
- [Configuring the Port Adapter Ports, page 28](#)
- [Configuring the Port Adapter Clock Source, page 28](#)
- [Disaster Recovery for CMM Software Upgrades, page 29](#)
- [Regulatory Standards Compliance, page 31](#)
- [Related Documentation, page 31](#)
- [Obtaining Documentation, page 32](#)
- [Documentation Feedback, page 33](#)
- [Cisco Product Security Overview, page 33](#)
- [Obtaining Technical Assistance, page 34](#)
- [Obtaining Additional Publications and Information, page 35](#)

## Front Panel Descriptions

These sections describe the front panel features of the CMM and the port adapters:

- [CMM, page 2](#)
- [6-Port T1 and E1 Port Adapters, page 4](#)
- [24-Port FXS Port Adapter, page 5](#)
- [Ad-Hoc Conferencing and Transcoding Port Adapter, page 5](#)

## CMM

The front panel features of the CMM are as follows:

- **STATUS LED**—When the CMM powers up, it initializes various hardware components and communicates with the supervisor engine. The STATUS LED shows the dialog with the supervisor engine and the results of the initialization. During the normal initialization sequence, the STATUS LED changes from off to red, to orange, and then to green. [Table 1](#) describes the STATUS LED operation.

- Port adapter slots—[Figure 1](#) shows the E1 port adapter in the left and middle slots, with a blank filler plate in the right slot.
- REAR MODULE STATUS LED—[Table 2](#) describes the REAR MODULE STATUS LED operation.

**Note**

For information on the supervisor engine LEDs, refer to the *Catalyst 6500 Series Switch Supervisor Engine Guide* at this URL:

[http://www.cisco.com/univercd/cc/td/doc/product/lan/cat6000/6000hw/supe\\_gd/index.htm](http://www.cisco.com/univercd/cc/td/doc/product/lan/cat6000/6000hw/supe_gd/index.htm)

**Figure 1 CMM Front Panel Features**

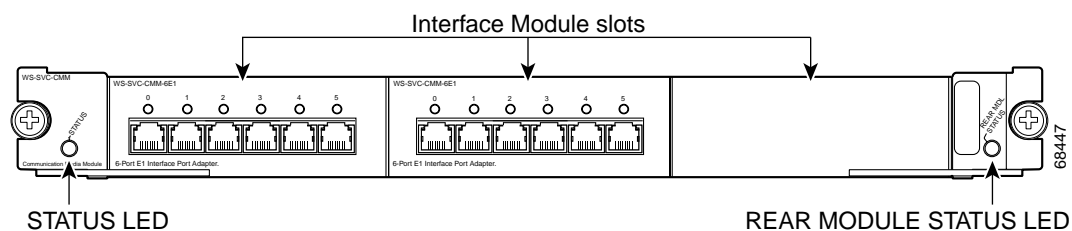

**Table 1 CMM STATUS LED**

Color	Description
Off	<ul style="list-style-type: none"> <li>• The module is waiting for the supervisor engine to grant power.</li> <li>• The module is not online.</li> <li>• The module is not receiving power, which could be caused by the following: <ul style="list-style-type: none"> <li>– Power is not available to the module.</li> <li>– Module temperature is over the limit<sup>1</sup>.</li> </ul> </li> </ul>
Red	<ul style="list-style-type: none"> <li>• The module is released from reset by the supervisor engine and is booting.</li> <li>• If the boot code fails to execute, the LED stays red after power up.</li> </ul>
Orange	<ul style="list-style-type: none"> <li>• The module is initializing hardware or communicating with the supervisor engine.</li> <li>• A fault occurred during the initialization sequence.</li> <li>• If the module fails to download its Field Programmable Gate Arrays (FPGAs) on startup, it continues initializing and is granted module online status from the supervisor engine, but the LED stays orange.</li> <li>• If the module is not granted module online status from the supervisor engine, the LED stays orange. This problem could be caused by the supervisor engine detecting a failure in an external loopback test that it issued to the module.</li> </ul>
Green	<ul style="list-style-type: none"> <li>• The module is operational; the supervisor engine has granted module online status.</li> </ul>

1. Enter the **show environment temperature mod** command to display the temperature of each of the four sensors on the module.

**Table 2 CMM Rear Module STATUS LED**

Color	Description
Green	Port adapter in slot 4 is up and operational.
Red	Port adapter in slot 4 is shut down.
No light	Slot 4 port adapter is not located by the system.

## 6-Port T1 and E1 Port Adapters

The front panel features of the 6-port T1 and E1 port adapters are as follows:

- Receive port LEDs—The LEDs on the front panel indicate the status of each T1 and E1 interface. [Table 3](#) describes the receive port LED operation.
- RJ-45 connectors—See the “[RJ-45 Port Connector and Cabling Specifications](#)” section on page 24 for details.

[Figure 2](#) shows the front panels of the 6-port T1 and E1 port adapters.

**Figure 2 6-Port T1 and E1 Port Adapter Front Panel Features**

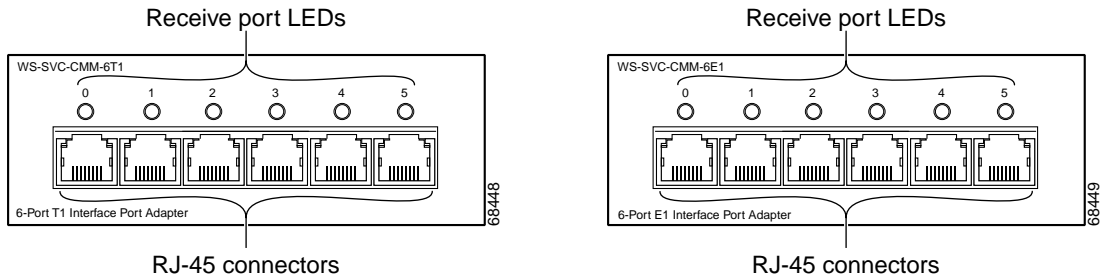

**Table 3 6-Port T1 and E1 Port Adapters Receive Port LEDs**

Color	Description
Green	T1/E1 interface is operational.
Red	T1/E1 receive alarm.
Yellow	T1/E1 remote alarm.
Off	T1/E1 interface has been administratively shut down, or there is no power.

## 24-Port FXS Port Adapter

The front panel features of the 24-port FXS port adapter are as follows:

- Receive port LEDs—The LEDs on the front panel indicate the status of each FXS interface. [Table 4](#) describes the receive port LED operation.
- RJ-21 connector—See the “[RJ-21 Port Connector and Cabling Specifications](#)” section on page 26 for details.



If the symbol of suitability with an overlaid cross appears above a port, you must not connect the port to a public network that follows the European Union standards. Connecting the port to this type of public network can cause severe personal injury or can damage the unit. Statement 1031

[Figure 3](#) shows the front panel of the 24-port FXS port adapter.

**Figure 3** 24-Port FXS Port Adapter Front Panel Features

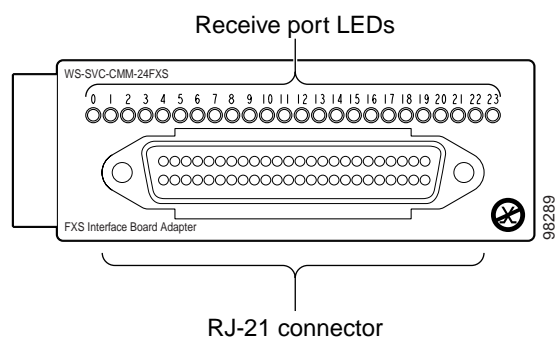

**Table 4** 24-Port FXS Port Adapter Receive Port LEDs

Color	Description
Green	Port is off-hook or ringing.
Off	Port is not active (connected device on-hook) or is disabled through the CLI.

## Ad-Hoc Conferencing and Transcoding Port Adapter

The front panel features of the ad-hoc conferencing and transcoding port adapter are shown in [Figure 4](#), and the STATUS LED is described in [Table 5](#).

**Figure 4** Ad-hoc Conferencing and Transcoding Port Adapter Front Panel Features

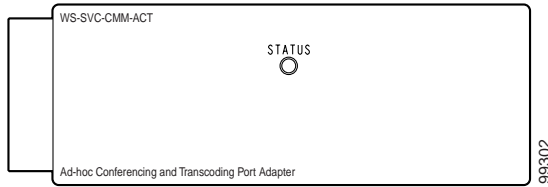

**Table 5** Ad-hoc Conferencing and Transcoding Port Adapter STATUS LED

Color	Description
Green	Port adapter is up and operational.
Red	Port adapter is shut down.
Off	Port adapter is not located by the system.

## Requirements

These sections describe the hardware and software requirements:

- [Hardware Requirements, page 6](#)
- [Software Requirements, page 7](#)

## Hardware Requirements

The hardware requirements for the CMM are as follows:

- Catalyst 6500 series switch.
- Cisco 7600 series router.
- A Supervisor Engine 1, Supervisor Engine 2, or Supervisor Engine 720—The supervisor engine can have an MSFC, MSFC2, or MSFC3, but the CMM does not require one for configuration or operation.
- Port adapters—You can install up to three T1, E1, or FXS port adapters into slots 1 through 3 on the CMM base module.

You can install up to four ACT port adapters into the CMM base module. (The internally located slot 4 is reserved for the ACT port adapter.)



**Note** You cannot mix T1 port adapters with E1 port adapters, but any other combination of port adapters is supported.

- CMM module blank filler plate (WS-SVC-CMM-BLANK) for unused port adapter slots.

## Software Requirements

For software requirements, refer to the *Release Notes for the Cisco Catalyst 6500 Series and the Cisco 7600 Series Communication Media Module* at this URL:

[http://www.cisco.com/univercd/cc/td/doc/product/lan/cat6000/mod\\_1cn/cmm/index.htm](http://www.cisco.com/univercd/cc/td/doc/product/lan/cat6000/mod_1cn/cmm/index.htm)

## Safety Overview

Throughout this publication, safety warnings appear in procedures that, if performed incorrectly, can harm you. A warning symbol precedes each warning statement.



---

### IMPORTANT SAFETY INSTRUCTIONS

This warning symbol means danger. You are in a situation that could cause bodily injury. Before you work on any equipment, be aware of the hazards involved with electrical circuitry and be familiar with standard practices for preventing accidents. Use the statement number provided at the end of each warning to locate its translation in the translated safety warnings that accompanied this device. Statement 1071

---

### SAVE THESE INSTRUCTIONS

---



---

**Ultimate disposal of this product should be handled according to all national laws and regulations.** Statement 1040

---



---

**Only trained and qualified personnel should be allowed to install, replace, or service this equipment.** Statement 1030

---



---

**If the symbol of suitability with an overlaid cross appears above a port, you must not connect the port to a public network that follows the European Union standards. Connecting the port to this type of public network can cause severe personal injury or can damage the unit.** Statement 1031

---



---

**During this procedure, wear grounding wrist straps to avoid ESD damage to the card. Do not directly touch the backplane with your hand or any metal tool, or you could shock yourself.** Statement 94

---



---

**Invisible laser radiation may be emitted from disconnected fibers or connectors. Do not stare into beams or view directly with optical instruments.** Statement 1051

---



Warning

**Blank faceplates and cover panels serve three important functions: they prevent exposure to hazardous voltages and currents inside the chassis; they contain electromagnetic interference (EMI) that might disrupt other equipment; and they direct the flow of cooling air through the chassis. Do not operate the system unless all cards, faceplates, front covers, and rear covers are in place.**

Statement 1029



Warning

**Hazardous voltage or energy is present on the backplane when the system is operating. Use caution when servicing.** Statement 1034



Warning

**Before opening the unit, disconnect the telephone-network cables to avoid contact with telephone-network voltages.** Statement 1041



Warning

**Do not work on the system or connect or disconnect cables during periods of lightning activity.**

Statement 1001



Warning

**Never install telephone jacks in wet locations unless the jack is specifically designed for wet locations.** Statement 1036



Warning

**Never touch uninsulated telephone wires or terminals unless the telephone line has been disconnected at the network interface.** Statement 1037



Warning

**Hazardous network voltages are present in WAN ports regardless of whether power to the unit is OFF or ON. To avoid electric shock, use caution when working near WAN ports. When detaching cables, detach the end away from the unit first.** Statement 1026



Warning

**To avoid electric shock, do not connect safety extra-low voltage (SELV) circuits to telephone-network voltage (TNV) circuits. LAN ports contain SELV circuits, and WAN ports contain TNV circuits. Some LAN and WAN ports both use RJ-45 connectors. Use caution when connecting cables.** Statement 1021



Warning

**To reduce the risk of fire, use only No. 26 AWG or larger telecommunication line cord.** Statement 1023



# Required Tools



Warning

**Only trained and qualified personnel should be allowed to install, replace, or service this equipment.** Statement 1030

These tools are required to remove and replace the CMM and port adapters:

- Flat-blade screwdriver (for CMM)
- Number 1 Phillips screwdriver (for the screws and standoffs)
- Antistatic mat or foam pad
- Your own ESD-prevention equipment or the disposable grounding wrist strap that is included with all upgrade kits, field-replaceable units (FRUs), and spares

Whenever you handle a module, always use a wrist strap or other grounding device to prevent electrostatic discharge (ESD). For information on preventing ESD, refer to the “Preventing ESD” section of the *Regulatory Compliance and Safety Information* publication.

## Installing and Removing the CMM

This section describes the procedures for installing and removing the CMM:

- [Installing the CMM, page 9](#)
- [Removing the CMM, page 16](#)

## Installing the CMM

This section describes how to install the CMM into the Catalyst 6500 series switch or the Cisco 7600 series router.



Note

All modules, including the supervisor engine (if you have redundant supervisor engines), support hot swapping. You can add, replace, or remove modules without interrupting the system power or causing other software or interfaces to shut down. For more information about hot-swapping modules, refer to the *Catalyst 6500 Series Switch Module Installation Guide*.



Warning

**During this procedure, wear grounding wrist straps to avoid ESD damage to the card. Do not directly touch the backplane with your hand or any metal tool, or you could shock yourself.** Statement 94

To install the CMM into the Catalyst 6500 series switch or the Cisco 7600 series router, perform these steps:

- 
- Step 1** Make sure that you take the necessary precautions to prevent ESD damage.
- Step 2** Choose a slot for the CMM.
- Step 3** Verify that there is enough clearance to accommodate any interface equipment that you will connect directly to the module ports. If possible, place modules between empty slots that contain only module filler plates.
- Step 4** Verify that the captive installation screws are tightened on all modules that are installed in the chassis. This action ensures that the EMI gaskets on all modules are fully compressed to maximize the opening space for the replacement module.



---

**Note** If the captive installation screws are loose, the EMI gaskets on the installed modules will push adjacent modules toward the open slot, reducing the opening size and making it difficult to install the replacement module.

---

- Step 5** Remove the module filler plate by removing the two Phillips pan-head screws from the filler plate. (To remove a module, refer to the [“Removing the CMM” section on page 16.](#))
- Step 6** Fully open both ejector levers on the new or replacement module. (See [Figure 5.](#))
- Step 7** Depending on the orientation of the slots in the chassis (horizontal or vertical), perform one of the following sets of substeps:

#### Horizontal slots

- a. Position the module in the slot. Make sure that you align the sides of the module carrier with the slot guides on each side of the slot. (See [Figure 5.](#))
- a. Carefully slide the module into the slot until the EMI gasket along the top edge of the module makes contact with the module in the slot above it and both ejector levers have closed to approximately 45 degrees with respect to the module faceplate. (See [Figure 6.](#))

Figure 5 Positioning the Module in a Horizontal Slot Chassis

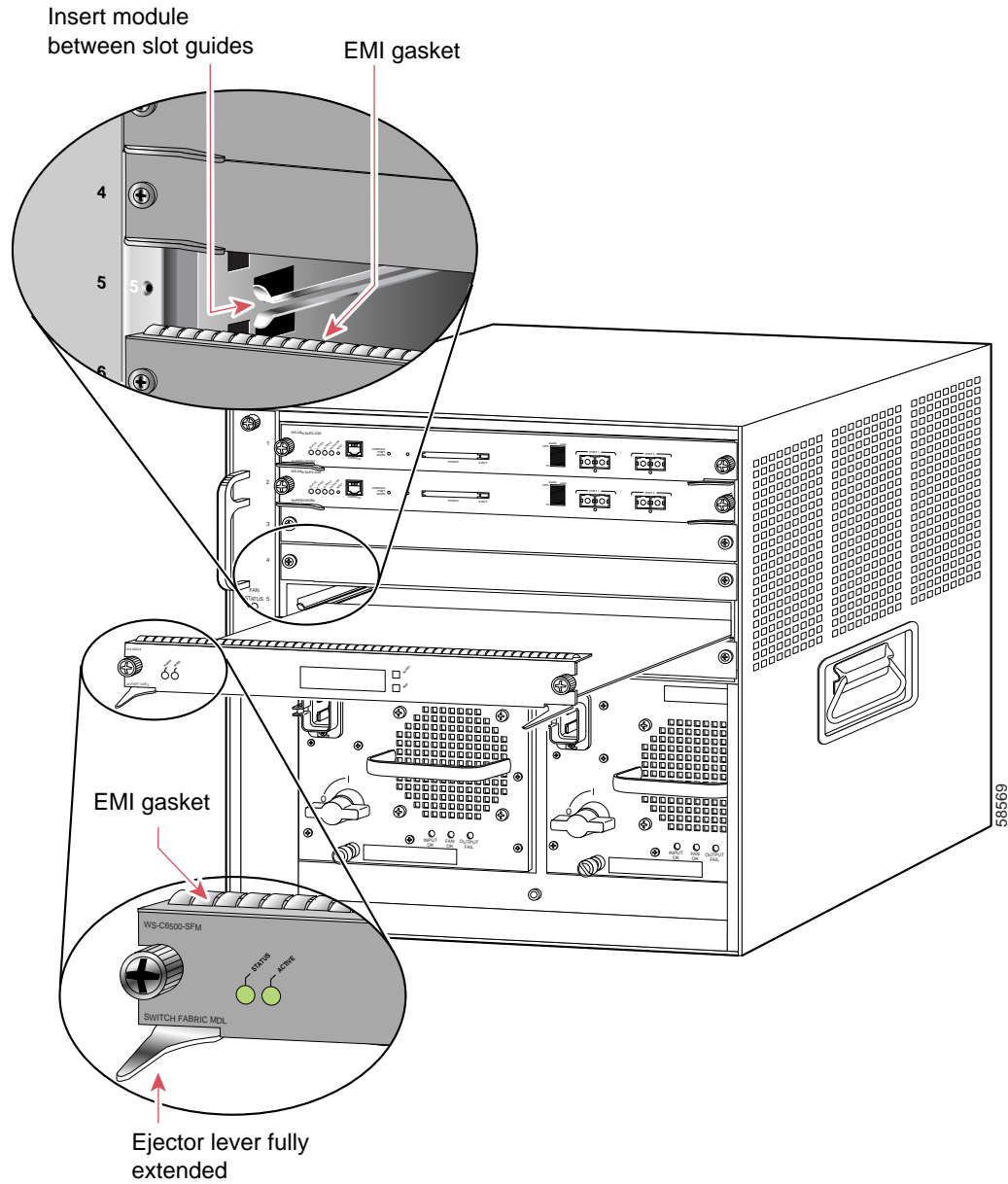
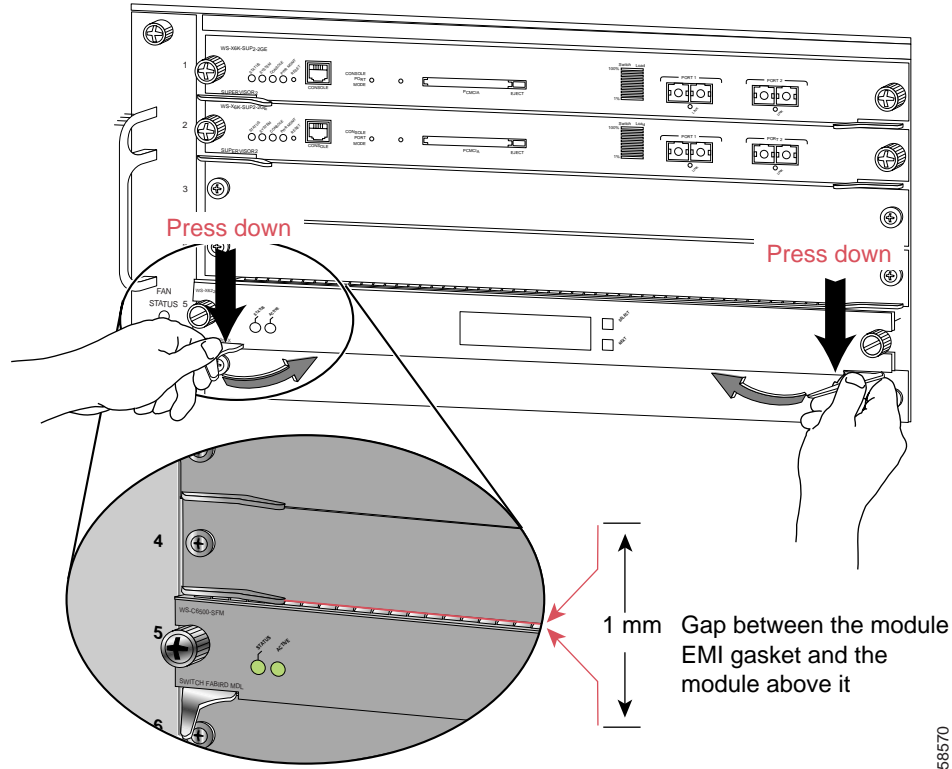

Figure 6 Clearing the EMI Gasket in a Horizontal Slot Chassis



- b. Using the thumb and forefinger of each hand, grasp the two ejector levers and press down to create a small (0.040 inch [1 mm]) gap between the EMI gasket and the module above it. (See [Figure 6.](#))

  
**Caution**

Pressing down too firmly on the levers will bend and damage them.

- c. While pressing down, simultaneously close the left and right ejector levers to fully seat the module in the backplane connector. The ejector levers are fully closed when they are flush with the module faceplate. (See [Figure 7.](#))

58570

**Figure 7** Ejector Lever Closure in a Horizontal Slot Chassis

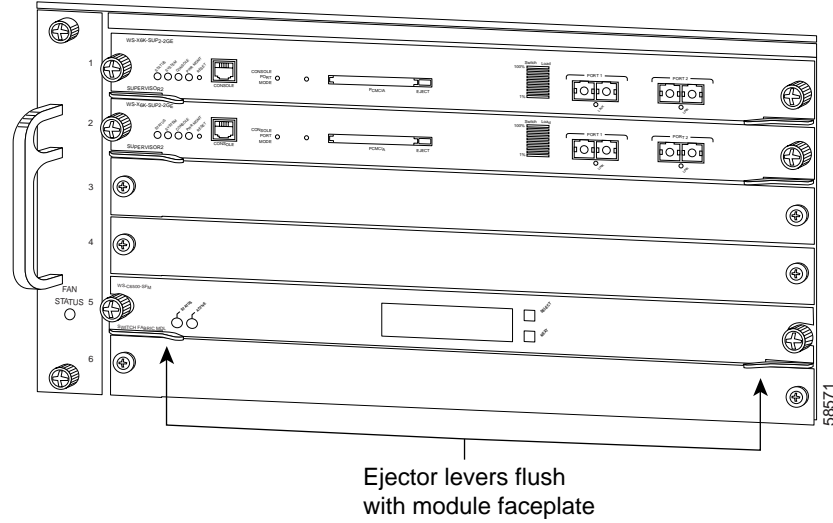

**Note** Failure to fully seat the module in the backplane connector can result in error messages.

- d. Tighten the two captive installation screws on the module.



**Note** Make sure that the ejector levers are fully closed before tightening the captive installation screws.

#### Vertical slots

- a. Position the module in the slot. (See [Figure 8](#).) Make sure that you align the sides of the module carrier with the slot guides on the top and bottom of the slot.

**Figure 8** Positioning the Module in a Vertical Slot Chassis

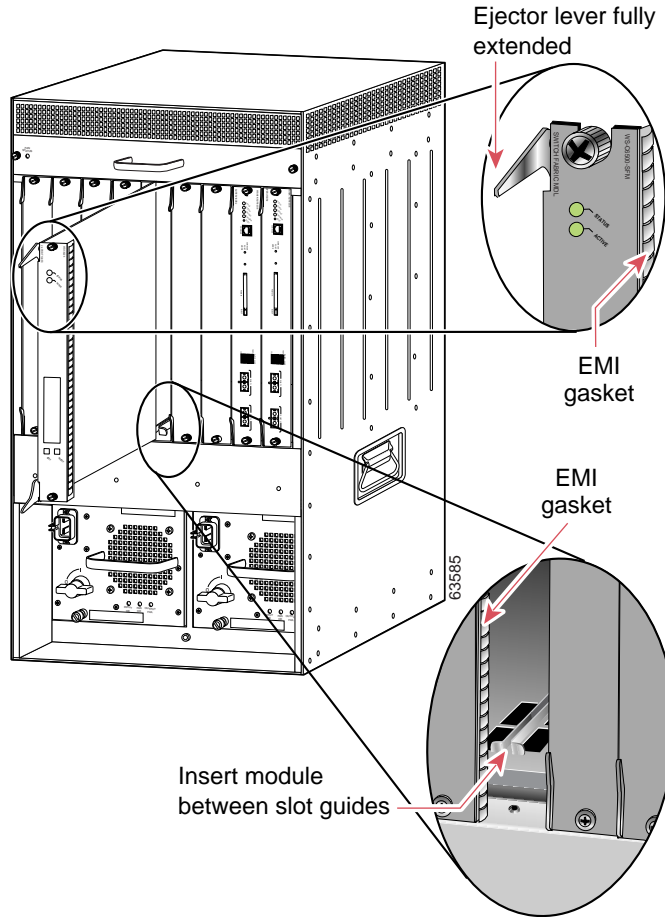

- b. Carefully slide the module into the slot until the EMI gasket along the right edge of the module makes contact with the module in the slot adjacent to it and both ejector levers have closed to approximately 45 degrees with respect to the module faceplate. (See [Figure 9](#).)
- c. Using the thumb and forefinger of each hand, grasp the two ejector levers and exert a slight pressure to the left, deflecting the module approximately 0.040 inches (1 mm) to create a small gap between the module's EMI gasket and the module adjacent to it. (See [Figure 9](#).)

Figure 9 Clearing the EMI Gasket in a Vertical Slot Chassis

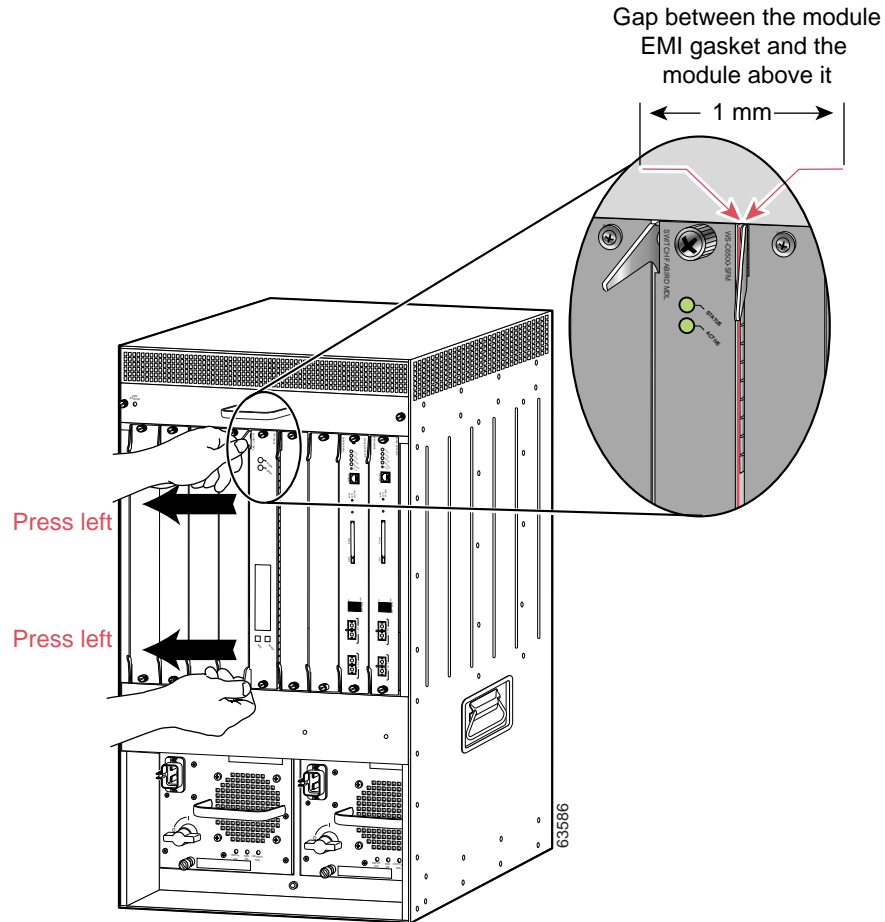

**Caution**

Exerting too much pressure on the ejector levers will bend and damage them.

- d. While pressing on the ejector levers, simultaneously close them to fully seat the module in the backplane connector. The ejector levers are fully closed when they are flush with the module faceplate. (See [Figure 10](#).)

Figure 10 Ejector Lever Closure in a Vertical Slot Chassis

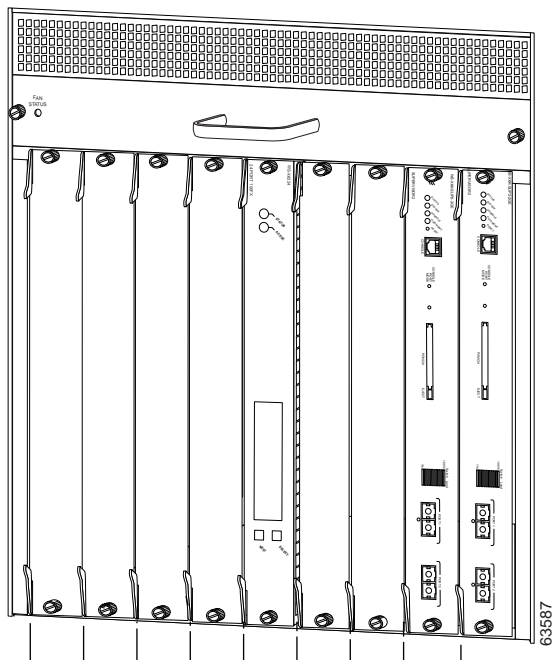

All ejector levers flush with module faceplate

- e. Tighten the two captive installation screws on the module.



**Note** Make sure that the ejector levers are fully closed before tightening the captive installation screws.

This completes the CMM installation procedure.

## Removing the CMM

This section describes how to remove the CMM from a Catalyst 6500 series switch or the Cisco 7600 series router.



**Caution**

During this procedure, wear grounding wrist straps to avoid ESD damage to the module. Do not directly touch the backplane with your hand or any metal tool, or you could shock yourself.



**Warning**

**Invisible laser radiation may be emitted from disconnected fibers or connectors. Do not stare into beams or view directly with optical instruments.** Statement 1051



To remove a module from the chassis, perform these steps:

- 
- Step 1** Disconnect any network interface cables that are attached to the module.
- Step 2** Verify that the captive installation screws on all of the modules in the chassis are tight.
- This step assures that the space that is created by the removed module is maintained.



---

**Note** If the captive installation screws are loose, the electromagnetic interference (EMI) gaskets on the installed modules will push the modules toward the open slot, reducing the opening size and making it difficult to install the replacement module.

---

- Step 3** Loosen the two captive installation screws on the module.
- Step 4** Depending on the orientation of the slots in the chassis (horizontal or vertical), perform one of the following sets of substeps:

**Horizontal slots**

- a. Place your thumbs on the left and right ejector levers, and simultaneously rotate the levers outward to unseat the module from the backplane connector.
- b. Grasp the front edge of the module, and slide the module part of the way out of the slot. Place your other hand under the module to support the weight of the module. Do not touch the module circuitry.

**Vertical slots**

- a. Place your thumbs on the ejector levers that are located at the top and bottom of the module, and simultaneously rotate the levers outward to unseat the module from the backplane connector.
- b. Grasp the edges of the module, and slide the module straight out of the slot. Do not touch the module circuitry.

- Step 5** Place the module on an antistatic mat or antistatic foam, or immediately reinstall it in another slot.
- Step 6** If the slot from which you removed the module is to remain empty, install a module filler plate to keep dust out of the chassis and to maintain proper airflow through the chassis.



**Warning**

---

**Blank faceplates and cover panels serve three important functions: they prevent exposure to hazardous voltages and currents inside the chassis; they contain electromagnetic interference (EMI) that might disrupt other equipment; and they direct the flow of cooling air through the chassis. Do not operate the system unless all cards, faceplates, front covers, and rear covers are in place.**

Statement 1029

---

# Removing and Replacing Port Adapters

Follow the procedures in this section to remove and replace the port adapters on the CMM:

- [Removing a Port Adapter from CMM Slots 1 through 3, page 18](#)
- [Installing a Port Adapter in CMM Slots 1 through 3, page 21](#)
- [Installing and Removing an Ad-Hoc Conferencing and Transcoding Port Adapter in Slot 4, page 22](#)

## Removing a Port Adapter from CMM Slots 1 through 3



Note

When you face the CMM front panel, slot 1 is on the left, slot 2 is in the middle, and slot 3 is on the right. Slot 4 is located internally. (See [Figure 13](#).)

To remove a port adapter, perform these steps:



Warning

**Hazardous voltage or energy is present on the backplane when the system is operating. Use caution when servicing.** Statement 1034

- Step 1** Remove the CMM from the Catalyst 6500 series switch or the Cisco 7600 series router; see the [“Removing the CMM” section on page 16](#).
- Step 2** Carefully place the CMM, component-side down, on an antistatic mat or foam pad, with the front of the CMM facing toward you. (See [Figure 11](#).)
- Step 3** Remove the two Phillips screws securing the port adapter. (See [Figure 11](#).)
- Step 4** Carefully turn the CMM component-side up and place it on the antistatic mat or foam pad.
- Step 5** Remove the two standoffs and the two remaining Phillips screws securing the port adapter. (See [Figure 12](#).)
- Step 6** Note the location of the two connectors in [Figure 13](#) and remove the port adapter, taking care when lifting up and disconnecting the port adapter from the connectors.



Tip

To unseat the port adapter from the two connectors, grasp the rear of the port adapter with one hand, and gently but firmly pull up on the rear of the port adapter until it is free of the connectors.

- Step 7** Place the removed port adapter in an antistatic bag.
- Step 8** If leaving an empty slot, install a blank filler plate.

  
Warning

Blank faceplates and cover panels serve three important functions: they prevent exposure to hazardous voltages and currents inside the chassis; they contain electromagnetic interference (EMI) that might disrupt other equipment; and they direct the flow of cooling air through the chassis. Do not operate the system unless all cards, faceplates, front covers, and rear covers are in place.

Statement 1029

- Step 9** To install the CMM into the Catalyst 6500 series switch or the Cisco 7600 series router, see the [“Installing the CMM” section on page 9](#).

*Figure 11 CMM (Bottom View)*

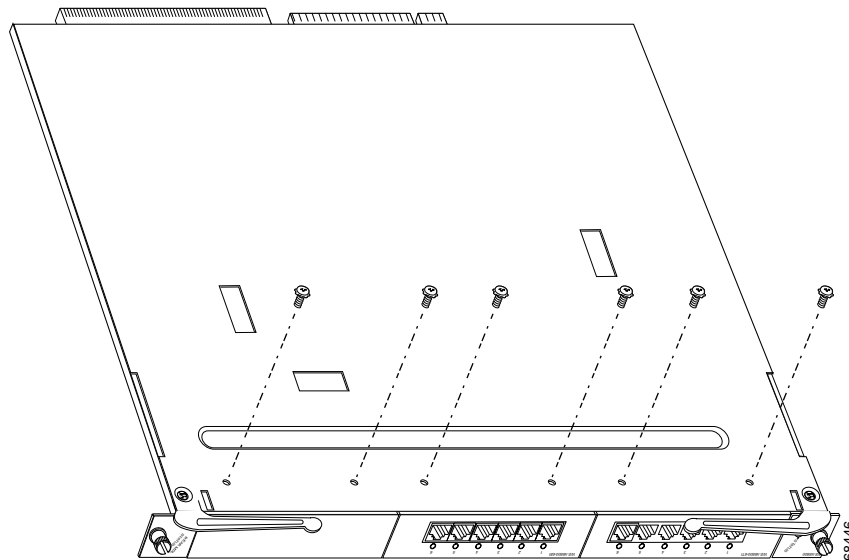

Phillips screws (6)  
(installed from bottom)

Figure 12 CMM (Top View with Port Adapters Installed)

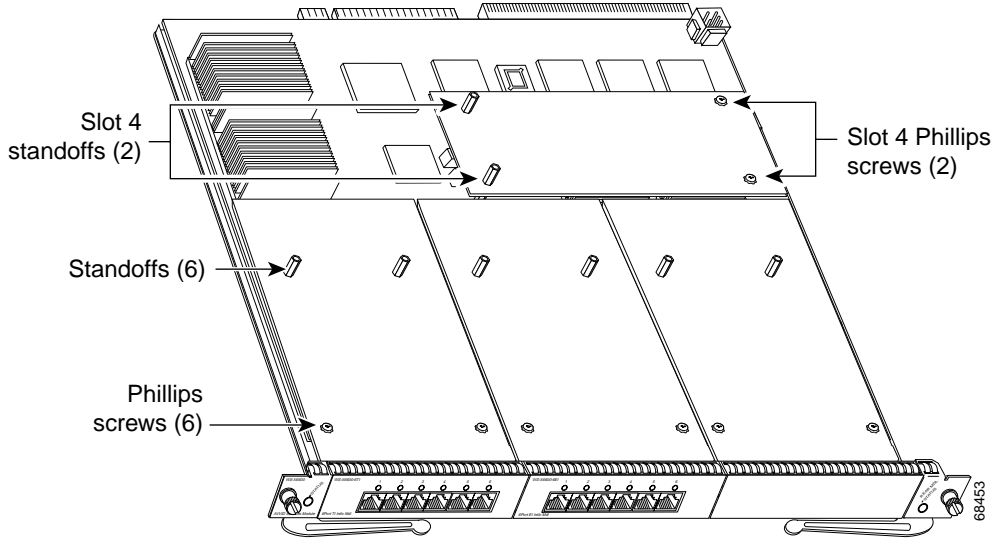
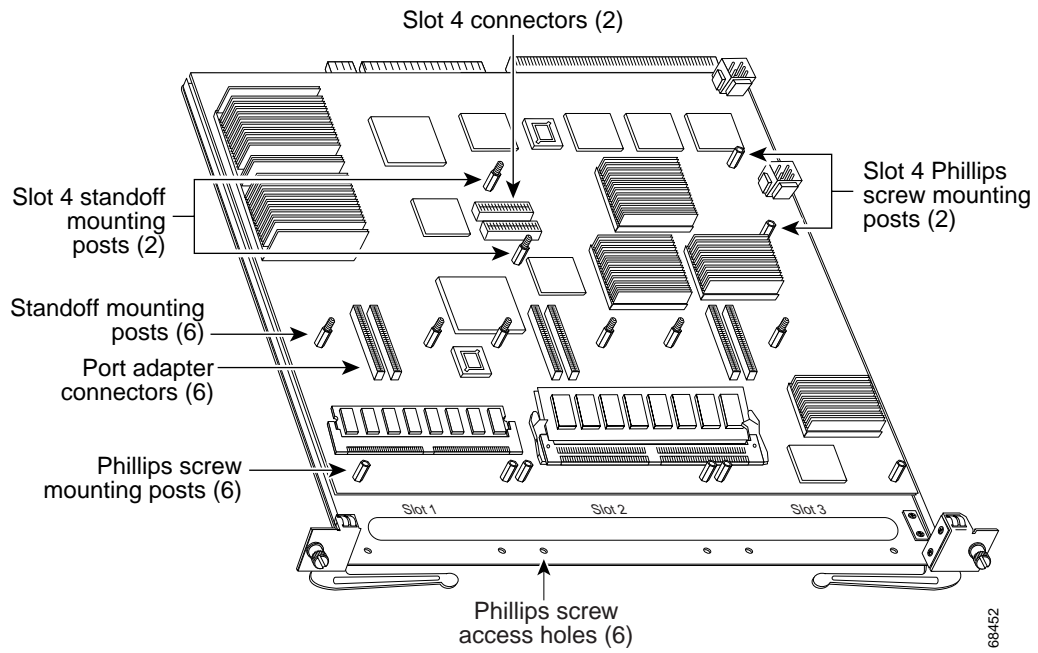

Figure 13 CMM (Top View with Port Adapters Removed)



## Installing a Port Adapter in CMM Slots 1 through 3

**Note**

When you face the CMM front panel, slot 1 is on the left, slot 2 is in the middle, and slot 3 is on the right. Slot 4 is located internally. (See [Figure 13](#).)

To install a port adapter in CMM slots 1 through 3, perform these steps:

**Warning**

**Hazardous voltage or energy is present on the backplane when the system is operating. Use caution when servicing.** Statement 1034

- Step 1** Remove the CMM from the Catalyst 6500 series switch or the Cisco 7600 series router; see the [“Removing the CMM”](#) section on page 16.
- Step 2** Carefully place the CMM, component-side up, on an antistatic mat or foam pad, with the front of the CMM facing toward you.
- Step 3** If there is a blank filler plate installed, remove it.
- Step 4** Remove the new port adapter from its antistatic bag.
- Step 5** Locate the slot in which you are going to install the port adapter. Note the location of the following items (see [Figure 13](#)):
- Two port adapter connectors
  - Two standoff mounting posts
  - Two Phillips screw mounting posts
  - Two Phillips screw access holes
- Step 6** Align the port adapter with the mounting posts and mounting holes. Ensure that the connectors on the port adapter are aligned with the connectors on the CMM.
- Step 7** When all mounting posts and mounting holes are aligned, gently push down on the port adapter edges to ensure that the keys on the connectors are properly aligned. If necessary, while applying pressure with your left hand, rock the module up and down slightly with your right hand to seat the port adapter.

**Tip**

To seat the port adapter into the two connectors, grasp the rear of the port adapter with one hand, and gently but firmly push down on the rear of the port adapter until it is seated in the connectors. You will hear a distinctive “click” when the port adapter seats in the connectors.

**Caution**

Use care not to damage the connectors on the port adapter. If you damage a connector, you will have to return the port adapter to Cisco for repair.



**Caution**

Using the screws or standoffs to seat the port adapter could warp the port adapter. *Before* you install and tighten the securing screws, ensure that the port adapter is fully seated by visually verifying that the bottom of the port adapter is in contact with the top of the mounting posts.

- Step 8** Install the two standoffs and two Phillips screws to secure the port adapter. (See [Figure 12.](#))
- Step 9** Carefully turn the CMM component-side down, and place it on the antistatic mat or foam pad.
- Step 10** Install the two remaining Phillips screws. (See [Figure 11.](#))
- Step 11** Install the CMM into the Catalyst 6500 series switch or the Cisco 7600 series router; see the [“Installing the CMM”](#) section on page 9.

## Installing and Removing an Ad-Hoc Conferencing and Transcoding Port Adapter in Slot 4



**Note**

The ad-hoc conferencing and transcoding port adapter is the only port adapter that can be installed in slot 4. Slot 4 is located internally. (See [Figure 13.](#))



**Warning**

**Hazardous voltage or energy is present on the backplane when the system is operating. Use caution when servicing.** Statement 1034

Follow these procedures to remove and install an ad-hoc conferencing and transcoding port adapter in slot 4:

- [Removing an Ad-hoc Conferencing and Transcoding Port Adapter in Slot 4, page 22](#)
- [Installing an Ad-Hoc Conferencing and Transcoding Port Adapter in Slot 4, page 23](#)

### Removing an Ad-hoc Conferencing and Transcoding Port Adapter in Slot 4

To remove a port adapter in CMM slot 4, perform these steps:

- Step 1** Remove the CMM from the Catalyst 6500 series switch or Cisco 7600 series router; see the [“Removing the CMM”](#) section on page 16.
- Step 2** Carefully place the CMM, component side up, on an antistatic mat or foam pad, with the front of the CMM facing toward you.
- Step 3** In [Figure 13](#), note the location of the two slot 4 Phillips screw mounting posts. Remove the two Phillips screws that secure the right-hand side of the port adapter.

**Step 4** In [Figure 13](#), note the location of the two slot 4 standoff mounting posts. Remove the two mounting posts that secure the port adapter.

**Step 5** In [Figure 13](#), note the location of the two slot 4 connectors. Carefully remove the port adapter, taking care when lifting up and disconnecting the port adapter from the connectors.



**Tip**

To unseat the port adapter from the two connectors, grasp the left-hand side of the port adapter with one hand, and gently but firmly pull up on the port adapter until it is free of the connectors.

**Step 6** Place the removed port adapter in an antistatic bag.

**Step 7** Install the CMM into the Catalyst 6500 series switch or the Cisco 7600 series router; see the [“Installing the CMM” section on page 9](#).

## Installing an Ad-Hoc Conferencing and Transcoding Port Adapter in Slot 4

To install a port adapter in CMM slot 4, perform these steps:



**Note**

To install a port adapter in CMM slot 4, you need to remove the face plate from the port adapter. To remove the face plate, position the port adapter with the face plate facing toward you, turn the port adapter component side down on an antistatic mat or foam pad, and then remove the two Phillips screws that secure the face plate.

**Step 1** Remove the CMM from the Catalyst 6500 series switch or the Cisco 7600 series router; see the [“Removing the CMM” section on page 16](#).

**Step 2** Carefully place the CMM, component side up, on an antistatic mat or foam pad, with the front of the CMM facing toward you.

**Step 3** In [Figure 13](#), note the location of the two, slot-4 Phillips screw mounting posts, and note the location of the two, slot-4 standoff mounting posts.

**Step 4** Align the port adapter with the two slot 4 Phillips screw mounting posts and two slot 4 standoff mounting posts. Ensure that the connectors on the port adapter are aligned with the connectors on the CMM.

**Step 5** When all mounting posts and mounting holes are aligned, gently push down on the port adapter edges that ensure that the keys on the connectors are properly aligned. If necessary, while applying pressure with your left hand, rock the module up and down slightly with your right hand to seat the port adapter.



**Tip**

To seat the port adapter into the two connectors, grasp the left-hand side of the port adapter with one hand, and gently but firmly push down on the left-hand side of the port adapter until it is seated in the connectors. You will hear a distinctive “click” when the port adapter seats in the connectors.



**Caution**

Use care not to damage the connectors on the port adapter. If you damage a connector, you will have to return the port adapter to Cisco for repair.



**Caution**

Using the screws or standoffs to seat the port adapter could warp the port adapter. *Before* you install and tighten the securing screws, ensure that the port adapter is fully seated by visually verifying that the bottom of the port adapter is in contact with the top of the mounting posts.

- Step 6** Install the two standoffs and two Phillips screws to secure the port adapter. (See [Figure 12.](#))
- Step 7** Install the CMM into the Catalyst 6500 series switch or Cisco 7600 series router; see the [“Installing the CMM”](#) section on page 9.

## Verifying the Installation

Enter the **show module** *mod-num* command to verify that the system acknowledges the new CMM and has brought it online.

This example shows the output of the **show module** command with a CMM in slot 4:

```

Console> (enable) show module 4
Mod Slot Ports Module-Type           Model           Sub Status
-----
4   4     5     Communication Media Mod.  WS-SVC-CMM     no  ok

Mod Module-Name           Serial-Num
-----
4                          sad054206jc

Mod MAC-Address(es)           Hw     Fw     Sw
-----
4  00-01-64-46-6a-0e to 00-01-64-46-6a-17  1.0    12.2(2002012.2(20020530:100440
    
```

## RJ-45 Port Connector and Cabling Specifications



**Warning**

**Before opening the unit, disconnect the telephone-network cables to avoid contact with telephone-network voltages.** Statement 1041



**Warning**

**Do not work on the system or connect or disconnect cables during periods of lightning activity.** Statement 1001



**Warning**

**Never install telephone jacks in wet locations unless the jack is specifically designed for wet locations.** Statement 1036



**Warning**

**Never touch uninsulated telephone wires or terminals unless the telephone line has been disconnected at the network interface.** Statement 1037



  
Warning

Hazardous network voltages are present in WAN ports regardless of whether power to the unit is OFF or ON. To avoid electric shock, use caution when working near WAN ports. When detaching cables, detach the end away from the unit first. Statement 1026

  
Warning

To avoid electric shock, do not connect safety extra-low voltage (SELV) circuits to telephone-network voltage (TNV) circuits. LAN ports contain SELV circuits, and WAN ports contain TNV circuits. Some LAN and WAN ports both use RJ-45 connectors. Use caution when connecting cables. Statement 1021

  
Warning

To reduce the risk of fire, use only No. 26 AWG or larger telecommunication line cord. Statement 1023

The T1 and E1 port adapter RJ-45 port connector and cabling specifications are described in this section:

- [Figure 14](#) shows the RJ-45 port cable connector pin orientation.
- [Table 6](#) describes the RJ-45 port pinouts.

**Figure 14** RJ-45 Port Connector

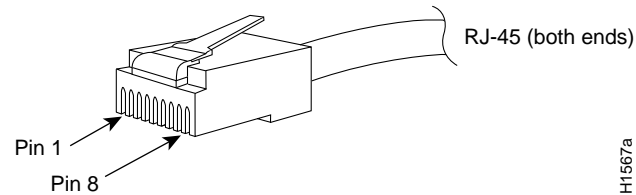

**Table 6** 6-Port T1 and E1 Port Adapter RJ-45 Port Pinouts

Pin <sup>1</sup>	Description
1	Receive R1
2	Receive T1
3	Not connected
4	Transmit R
5	Transmit T
6	Not connected
7	Not connected
8	Not connected

1. [Table 6](#) lists the pinouts for the RJ-45 port connector, not the pinouts of the cable connecting to the port.

# RJ-21 Port Connector and Cabling Specifications



Warning



If the symbol of suitability with an overlaid cross appears above a port, you must not connect the port to a public network that follows the European Union standards. Connecting the port to this type of public network can cause severe personal injury or can damage the unit. Statement 1031



Caution

Do not connect the WS-SVC-CMM-24 FXS port adapter directly to a voicemail server, IVR application, or fax server if the servers have unused wiring pairs with voltage on them. We recommend that you connect the 25-pair cables to punch-down blocks and cross connect to the voicemail, IVR, or fax servers. If you do not use punch-down blocks and cross connects to the WS-SVC-CMM-24 FXS port adapter, you could damage the port adapter. For example, the FLT-8 card for the Octel 250 uses every other pair for its voice ports. The unused pairs have +36 VDC across ring-to-ground in an on-hook condition, and this high voltage has been known to damage the WS-SVC-CMM-24 FXS port adapter.

Use a standard RJ-21 Category 5 telco connector and cable to connect to the RJ-21 connector. Two types of RJ-21 connectors are shown in [Figure 15](#) and [Figure 16](#). A pinout for the module's RJ-21 connector is provided in [Table 7](#).

**Figure 15** RJ-21 Telco Interface 90-Degree Cable Connector

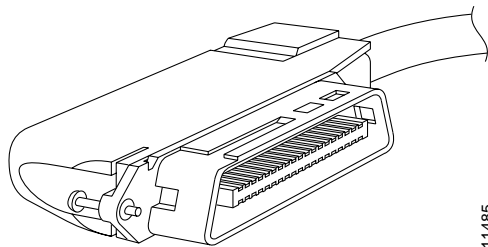

**Figure 16** RJ-21 Telco Interface 180-Degree Cable Connector

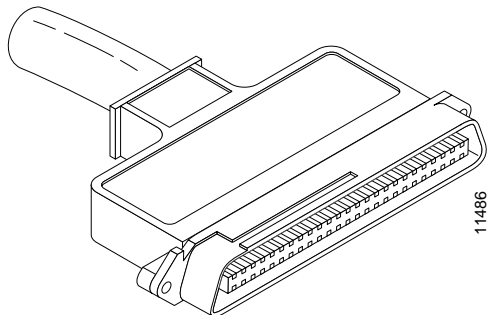

Table 7 RJ-21 Connector Pinouts

Port Number	Connector Pin Number	Signal	Port Number	Connector Pin Number	Signal
1	1 26	Ring Tip	13	13 38	Ring Tip
2	2 27	Ring Tip	14	14 39	Ring Tip
3	3 28	Ring Tip	15	15 40	Ring Tip
4	4 29	Ring Tip	16	16 41	Ring Tip
5	5 30	Ring Tip	17	17 42	Ring Tip
6	6 31	Ring Tip	18	18 43	Ring Tip
7	7 32	Ring Tip	19	19 44	Ring Tip
8	8 33	Ring Tip	20	20 45	Ring Tip
9	9 34	Ring Tip	21	21 46	Ring Tip
10	10 35	Ring Tip	22	22 47	Ring Tip
11	11 36	Ring Tip	23	23 48	Ring Tip
12	12 37	Ring Tip	24	24 49	Ring Tip
–	–	–	–	25, 50, 51, 52	GND

## Accessing the Port Adapter Ports

From the CMM command-line interface (CLI), you identify each port adapter by *interface\_name* followed by *slot\_num/port\_num*. For example, to configure the first port on a 6-port T1 port adapter that is installed in slot 2, specify **T1 2/0**. For the second port, specify **T1 2/1**, and so on.

## Configuring the Port Adapter Ports

Configuring the CMM interfaces is similar to configuring the voice interfaces on other Cisco products. CMM interface configuration requirements are dependent on your AVVID network requirements. For interface configuration procedures, refer to the Cisco IOS Voice, Video, and Fax documentation for your release at this URL:

<http://www.cisco.com/univercd/cc/td/doc/product/software/index.htm>



### Note

The CMM requires a static IP address. Obtaining an IP address through a DHCP server is not supported. You assign an IP address to the CMM Gigabit Ethernet backplane interface through the CLI by using the **interface GigabitEthernet1/0** command.

## Configuring the Port Adapter Clock Source

The CMM T1/E1 port adapter clock configuration is the same as the configuration on many other Cisco gateways. The CLI commands that are used for configuring the clock are identical to other gateways. To set clocking for individual T1 or E1 ports, enter the **clock source** command in controller configuration mode as follows:

```
clock source {line [primary | secondary {1..17}] | internal}
```

To return to the default configuration, use the **no clock source** command.



### Note

We do not recommend that you use the **clock source line** command. You must enter either the **clock source line primary** command or the **clock source line secondary** command.

If you configure the clock source for a port adapter port as **primary**, the Rx clock that is received from the remote end is used to supply the clock for all CMM T1/E1 ports that are configured for the internal clock on that CMM. Only one port adapter port can be configured as the **primary** clock source on a CMM. If you do not configure any of the port adapter ports as the **primary** clock source, the internal TDM system clock uses the free running clock on one of the port adapters.

If you configure the clock source for a port adapter port as **secondary**, you must also specify the priority preference level of the source. The system automatically switches among the secondary sources to use the highest level of preference that has the Rx clock available when the specified primary clock source is absent.

If you configure the clock source for a port adapter port as **internal**, the port uses the clock that is provided by the system. This system clock could be a CMM internal clock or the Rx clock from the port that is configured as the **primary** clock source.

# Disaster Recovery for CMM Software Upgrades



## Note

Disaster recovery is supported only on systems that are using Catalyst operating system software on the supervisor engine.

This section describes how to recover in the event that the CMM software image fails to load properly. If there is a corrupted image in the CMM bootflash, the CMM does not come online and stays at the ROMMON prompt. You will need to copy a new image to the supervisor engine Flash memory, download the image from the supervisor engine to the CMM bootflash, and configure the system by using the power management bits to control which image is booted when the CMM is reset.



## Note

The downloaded image must be the same version that was previously operating on the CMM. Failure to perform the disaster recovery with the same image version could result in corrupted port adapters.

These sections provide disaster recovery procedures:

- [Disaster Recovery for Supervisor Engine 1 and Supervisor Engine 2, page 29](#)
- [Disaster Recovery for Supervisor Engine 720, page 30](#)



## Tip

If the CMM image fails to load properly, a crash information file is generated and then saved in the CMM bootflash.

## Disaster Recovery for Supervisor Engine 1 and Supervisor Engine 2

For systems that use Catalyst operating system software on the supervisor engine, perform these steps:

- Step 1** Before performing the disaster recovery, remove the port adapters from the CMM. See the [“Removing and Replacing Port Adapters”](#) section on page 18 for removal procedures.
- Step 2** Enter the **copy tftp [device]** command to copy the golden image to the supervisor engine Flash memory where [device] can be either bootflash or slot0.
- Step 3** Enter the **set filename-alias slot0:ws-svc-cmm [device]:[golden-image]** command to translate the file name of the downloaded file. The [golden-image] is the file to be downloaded, and the [device] can be either bootflash or slot0. For example, the **set filename-alias slot0:ws-svc-cmm bootflash:abc** command sets the file named abc in bootflash to be downloaded.
- Step 4** Enter the **set module power down mod pm\_option** command to power down the CMM. Set the power management bits (pm\_option) to 10 if the supervisor engine is in slot 1. Set the power management bits to 11 if the supervisor engine is in slot 2.

- Step 5 Enter the **set poll disable** command to disable polling.
- Step 6 Enter the **set module power up *mod*** command to power up the CMM.  
When the CMM powers up, disaster recovery is complete.
- Step 7 After you complete the disaster recovery, enter the **clear filename-alias slot0:ws-svc-cmm** command to terminate the filename translation.
- Step 8 Set the power management bits of the CMM to zero (0). This step is necessary to prevent the download mechanism from triggering every time that the CMM is reset.
- Step 9 Enter the **set poll enable** command to enable polling.

## Disaster Recovery for Supervisor Engine 720



**Note** Disaster recovery is supported only on systems that are using Catalyst operating system software on the supervisor engine.



**Note** This procedure requires CMM software release 12.3(8)XY or later.



**Note** To successfully perform disaster recovery on the Supervisor Engine 720, you must have the latest ROMMON version on the CMM.



**Note** Supervisor Engine 720 does not have a slot0:. It has a disk0:.

For systems that use Catalyst operating system software on the supervisor engine, perform these steps:

- Step 1 Before performing the disaster recovery, remove all of the port adapters from the CMM. See the [“Removing and Replacing Port Adapters”](#) section on page 18 for removal procedures.
- Step 2 Enter the **copy tftp [device]** command to copy the golden image to the supervisor engine Flash memory where [device] is disk0:.
- Step 3 Enter the **set filename-alias disk0:ws-svc-cmm [device]:[golden-image]** command to translate the filename of the downloaded file. The [golden-image] is the file to be downloaded, and the [device] can be either bootflash or disk0. For example, the **set filename-alias disk0:ws-svc-cmm disk0:wscmm-i6s-mz.123.8.XY** command sets the file named wscmm-i6s-mz.123.8.XY in disk0: to be downloaded.
- Step 4 Enter the **set module power down *mod pm\_option*** command to power down the CMM. Set the power management bits (*pm\_option*) to 10 if the supervisor engine is in slot 5 or slot 7. Set the power management bits to 11 if the supervisor engine is in slot 6 or slot 8.
- Step 5 Enter the **set poll disable** command to disable polling.
- Step 6 Enter the **set module power up *mod*** command to power up the CMM.  
When the CMM powers up, disaster recovery is complete.

- Step 7** After you complete the disaster recovery, enter the **clear filename-alias disk0:ws-svc-cmm** command to terminate the filename translation.
- Step 8** After you complete the disaster recovery, set the power management bits of the CMM to zero (0). This step is necessary to prevent the download mechanism from triggering every time that the CMM is reset.
- Step 9** Enter the **set poll enable** command to enable polling.
- 

## Regulatory Standards Compliance

Catalyst 6500 series switches and modules comply with the regulatory standards that are listed in the *Regulatory Compliance and Safety Information for the Catalyst 6500 Series Switches* publication at this URL:

[http://www.cisco.com/univercd/cc/td/doc/product/lan/cat6000/6000hw/78\\_12928.htm](http://www.cisco.com/univercd/cc/td/doc/product/lan/cat6000/6000hw/78_12928.htm)

Cisco 7600 series routers comply with the regulatory standards that are listed in the *Regulatory Compliance and Safety Information for the Cisco 7600 Series Routers* publication at this URL:

[http://www.cisco.com/univercd/cc/td/doc/product/core/cis7600/rcsi/78\\_13690.htm](http://www.cisco.com/univercd/cc/td/doc/product/core/cis7600/rcsi/78_13690.htm)

## Related Documentation

For more detailed installation and configuration information, refer to these publications:

- *Regulatory Compliance and Safety Information for the Catalyst 6500 Series Switches*
- *Regulatory Compliance and Safety Information for the Cisco 7600 Series Routers*
- *Catalyst 6500 Series Switch Module Installation Guide*
- *Cisco 7600 Series Router Module Installation Guide*
- *Catalyst 6500 Series Switch Cisco IOS Software Configuration Guide*
- *Cisco 7600 Series Router Cisco IOS Software Configuration Guide*
- *Catalyst 6500 Series Switch Cisco IOS Command Reference*
- *Cisco 7600 Series Router Cisco IOS Command Reference*

# Obtaining Documentation

Cisco documentation and additional literature are available on Cisco.com. Cisco also provides several ways to obtain technical assistance and other technical resources. These sections explain how to obtain technical information from Cisco Systems.

## Cisco.com

You can access the most current Cisco documentation at this URL:

<http://www.cisco.com/univercd/home/home.htm>

You can access the Cisco website at this URL:

<http://www.cisco.com>

You can access international Cisco websites at this URL:

[http://www.cisco.com/public/countries\\_languages.shtml](http://www.cisco.com/public/countries_languages.shtml)

## Documentation DVD

Cisco documentation and additional literature are available in a Documentation DVD package, which may have shipped with your product. The Documentation DVD is updated regularly and may be more current than printed documentation. The Documentation DVD package is available as a single unit.

Registered Cisco.com users (Cisco direct customers) can order a Cisco Documentation DVD (product number DOC-DOCDVD=) from the Ordering tool or Cisco Marketplace.

Cisco Ordering tool:

<http://www.cisco.com/en/US/partner/ordering/>

Cisco Marketplace:

<http://www.cisco.com/go/marketplace/>

## Ordering Documentation

You can find instructions for ordering documentation at this URL:

[http://www.cisco.com/univercd/cc/td/doc/es\\_inpk/pdi.htm](http://www.cisco.com/univercd/cc/td/doc/es_inpk/pdi.htm)

You can order Cisco documentation in these ways:

- Registered Cisco.com users (Cisco direct customers) can order Cisco product documentation from the Ordering tool:  
<http://www.cisco.com/en/US/partner/ordering/>
- Nonregistered Cisco.com users can order documentation through a local account representative by calling Cisco Systems Corporate Headquarters (California, USA) at 408 526-7208 or, elsewhere in North America, by calling 1 800 553-NETS (6387).



# Documentation Feedback

You can send comments about technical documentation to [bug-doc@cisco.com](mailto:bug-doc@cisco.com).

You can submit comments by using the response card (if present) behind the front cover of your document or by writing to the following address:

Cisco Systems  
Attn: Customer Document Ordering  
170 West Tasman Drive  
San Jose, CA 95134-9883

We appreciate your comments.

## Cisco Product Security Overview

Cisco provides a free online Security Vulnerability Policy portal at this URL:

[http://www.cisco.com/en/US/products/products\\_security\\_vulnerability\\_policy.html](http://www.cisco.com/en/US/products/products_security_vulnerability_policy.html)

From this site, you can perform these tasks:

- Report security vulnerabilities in Cisco products.
- Obtain assistance with security incidents that involve Cisco products.
- Register to receive security information from Cisco.

A current list of security advisories and notices for Cisco products is available at this URL:

<http://www.cisco.com/go/psirt>

If you prefer to see advisories and notices as they are updated in real time, you can access a Product Security Incident Response Team Really Simple Syndication (PSIRT RSS) feed from this URL:

[http://www.cisco.com/en/US/products/products\\_psirt\\_rss\\_feed.html](http://www.cisco.com/en/US/products/products_psirt_rss_feed.html)

## Reporting Security Problems in Cisco Products

Cisco is committed to delivering secure products. We test our products internally before we release them, and we strive to correct all vulnerabilities quickly. If you think that you might have identified a vulnerability in a Cisco product, contact PSIRT:

- Emergencies—[security-alert@cisco.com](mailto:security-alert@cisco.com)
- Nonemergencies—[psirt@cisco.com](mailto:psirt@cisco.com)



Tip

We encourage you to use Pretty Good Privacy (PGP) or a compatible product to encrypt any sensitive information that you send to Cisco. PSIRT can work from encrypted information that is compatible with PGP versions 2.x through 8.x.

Never use a revoked or an expired encryption key. The correct public key to use in your correspondence with PSIRT is the one that has the most recent creation date in this public key server list:

<http://pgp.mit.edu:11371/pks/lookup?search=psirt%40cisco.com&op=index&exact=on>

In an emergency, you can also reach PSIRT by telephone:

- 1 877 228-7302
- 1 408 525-6532

## Obtaining Technical Assistance

For all customers, partners, resellers, and distributors who hold valid Cisco service contracts, Cisco Technical Support provides 24-hour-a-day, award-winning technical assistance. The Cisco Technical Support Website on Cisco.com features extensive online support resources. In addition, Cisco Technical Assistance Center (TAC) engineers provide telephone support. If you do not hold a valid Cisco service contract, contact your reseller.

### Cisco Technical Support Website

The Cisco Technical Support Website provides online documents and tools for troubleshooting and resolving technical issues with Cisco products and technologies. The website is available 24 hours a day, 365 days a year, at this URL:

<http://www.cisco.com/techsupport>

Access to all tools on the Cisco Technical Support Website requires a Cisco.com user ID and password. If you have a valid service contract but do not have a user ID or password, you can register at this URL:

<http://tools.cisco.com/RPF/register/register.do>



#### Note

Use the Cisco Product Identification (CPI) tool to locate your product serial number before submitting a web or phone request for service. You can access the CPI tool from the Cisco Technical Support Website by clicking the **Tools & Resources** link under Documentation & Tools. Choose **Cisco Product Identification Tool** from the Alphabetical Index drop-down list, or click the **Cisco Product Identification Tool** link under Alerts & RMAs. The CPI tool offers three search options: by product ID or model name; by tree view; or for certain products, by copying and pasting **show** command output. Search results show an illustration of your product with the serial number label location highlighted. Locate the serial number label on your product and record the information before placing a service call.

### Submitting a Service Request

Using the online TAC Service Request Tool is the fastest way to open S3 and S4 service requests. (S3 and S4 service requests are those in which your network is minimally impaired or for which you require product information.) After you describe your situation, the TAC Service Request Tool provides recommended solutions. If your issue is not resolved using the recommended resources, your service request is assigned to a Cisco TAC engineer. The TAC Service Request Tool is located at this URL:

<http://www.cisco.com/techsupport/servicerequest>

For S1 or S2 service requests or if you do not have Internet access, contact the Cisco TAC by telephone. (S1 or S2 service requests are those in which your production network is down or severely degraded.) Cisco TAC engineers are assigned immediately to S1 and S2 service requests to help keep your business operations running smoothly.

To open a service request by telephone, use one of the following numbers:

Asia-Pacific: +61 2 8446 7411 (Australia: 1 800 805 227)

EMEA: +32 2 704 55 55

USA: 1 800 553-2447

For a complete list of Cisco TAC contacts, go to this URL:

<http://www.cisco.com/techsupport/contacts>

## Definitions of Service Request Severity

To ensure that all service requests are reported in a standard format, Cisco has established severity definitions.

**Severity 1 (S1)**—Your network is “down,” or there is a critical impact to your business operations. You and Cisco will commit all necessary resources around the clock to resolve the situation.

**Severity 2 (S2)**—Operation of an existing network is severely degraded, or significant aspects of your business operation are negatively affected by inadequate performance of Cisco products. You and Cisco will commit full-time resources during normal business hours to resolve the situation.

**Severity 3 (S3)**—Operational performance of your network is impaired, but most business operations remain functional. You and Cisco will commit resources during normal business hours to restore service to satisfactory levels.

**Severity 4 (S4)**—You require information or assistance with Cisco product capabilities, installation, or configuration. There is little or no effect on your business operations.

## Obtaining Additional Publications and Information

Information about Cisco products, technologies, and network solutions is available from various online and printed sources.

- Cisco Marketplace provides a variety of Cisco books, reference guides, and logo merchandise. Visit Cisco Marketplace, the company store, at this URL:

<http://www.cisco.com/go/marketplace/>

- *Cisco Press* publishes a wide range of general networking, training and certification titles. Both new and experienced users will benefit from these publications. For current Cisco Press titles and other information, go to Cisco Press at this URL:

<http://www.ciscopress.com>

- *Packet* magazine is the Cisco Systems technical user magazine for maximizing Internet and networking investments. Each quarter, Packet delivers coverage of the latest industry trends, technology breakthroughs, and Cisco products and solutions, as well as network deployment and troubleshooting tips, configuration examples, customer case studies, certification and training information, and links to scores of in-depth online resources. You can access Packet magazine at this URL:

<http://www.cisco.com/packet>

- *iQ Magazine* is the quarterly publication from Cisco Systems designed to help growing companies learn how they can use technology to increase revenue, streamline their business, and expand services. The publication identifies the challenges facing these companies and the technologies to help solve them, using real-world case studies and business strategies to help readers make sound technology investment decisions. You can access iQ Magazine at this URL:

<http://www.cisco.com/go/iqmagazine>

- *Internet Protocol Journal* is a quarterly journal published by Cisco Systems for engineering professionals involved in designing, developing, and operating public and private internets and intranets. You can access the Internet Protocol Journal at this URL:

<http://www.cisco.com/ipj>

- World-class networking training is available from Cisco. You can view current offerings at this URL:

<http://www.cisco.com/en/US/learning/index.html>

---

This document is to be used in conjunction with the documents listed in the “Related Documentation” section.

CCSP, CCVP, the Cisco Square Bridge logo, Follow Me Browsing, and StackWise are trademarks of Cisco Systems, Inc.; Changing the Way We Work, Live, Play, and Learn, and iQuick Study are service marks of Cisco Systems, Inc.; and Access Registrar, Aironet, ASIST, BPX, Catalyst, CCDA, CCDP, CCIE, CCIP, CCNA, CCNP, Cisco, the Cisco Certified Internetwork Expert logo, Cisco IOS, Cisco Press, Cisco Systems, Cisco Systems Capital, the Cisco Systems logo, Cisco Unity, Empowering the Internet Generation, Enterprise/Solver, EtherChannel, EtherFast, EtherSwitch, Fast Step, FormShare, GigaDrive, GigaStack, HomeLink, Internet Quotient, IOS, IP/TV, iQ Expertise, the iQ logo, iQ Net Readiness Scorecard, LightStream, Linksys, MeetingPlace, MGX, the Networkers logo, Networking Academy, Network Registrar, *Packet*, PIX, Post-Routing, Pre-Routing, ProConnect, RateMUX, ScriptShare, SlideCast, SMARTnet, StrataView Plus, TeleRouter, The Fastest Way to Increase Your Internet Quotient, and TransPath are registered trademarks of Cisco Systems, Inc. and/or its affiliates in the United States and certain other countries.

All other trademarks mentioned in this document or Website are the property of their respective owners. The use of the word partner does not imply a partnership relationship between Cisco and any other company. (0502R)

 Printed in the USA on recycled paper containing 10% postconsumer waste.

## Free Manuals Download Website

<http://myh66.com>

<http://usermanuals.us>

<http://www.somanuals.com>

<http://www.4manuals.cc>

<http://www.manual-lib.com>

<http://www.404manual.com>

<http://www.luxmanual.com>

<http://aubethermostatmanual.com>

Golf course search by state

<http://golfingnear.com>

Email search by domain

<http://emailbydomain.com>

Auto manuals search

<http://auto.somanuals.com>

TV manuals search

<http://tv.somanuals.com>