



# Cisco CompactFlash Adapter for Bootflash Upgrade Installation Note

---

**Product Numbers: WS-CF-UPG=, CF-ADAPTER=**

This publication describes how to replace the switch processor (SP) bootflash memory module (DIMM) with CompactFlash on the Supervisor Engine 720.

## Contents

This publication consists of these sections:

- [Safety Overview, page 2](#)
- [Installing the SP Bootflash Memory Upgrade Kit, page 8](#)
- [Safety Warning Translations, page 27](#)
- [Obtaining Documentation, page 33](#)
- [Documentation Feedback, page 34](#)
- [Cisco Product Security Overview, page 34](#)
- [Product Alerts and Field Notices, page 35](#)
- [Obtaining Technical Assistance, page 36](#)
- [Obtaining Additional Publications and Information, page 38](#)



### Note

---

For translations of the warnings in this publication, see the [“Safety Warning Translations” section on page 27](#).

---

The CompactFlash adapter (see [Figure 1](#)) is a device that plugs into the SP bootflash DIMM socket on the Supervisor Engine 720. This device expands the amount of bootflash memory that is available. The kits contain a CompactFlash adapter with the CompactFlash installed. The CompactFlash adapter contains a Cisco IOS image (12.2(18)SXE5 or greater). See your Cisco IOS release notes for the exact release information.



---

**Corporate Headquarters:**

**Cisco Systems, Inc., 170 West Tasman Drive, San Jose, CA 95134-1706 USA**

© 2005–2006 Cisco Systems, Inc. All rights reserved.



**Note**

The CompactFlash adapter is not supported in systems that run the Catalyst operating system.

This upgrade is applicable only for the SP bootflash; it is independent from the SP DRAM.

**Figure 1 CompactFlash Adapter**

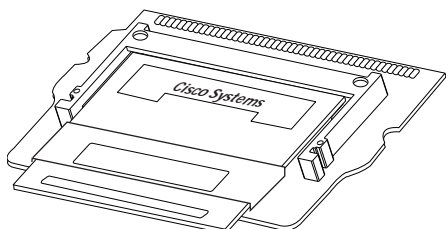

## Safety Overview

Safety warnings appear throughout this publication in procedures that may harm you if performed incorrectly. A warning symbol precedes each warning statement.

### Statement 1071—Warning Definition



**Warning**

#### **IMPORTANT SAFETY INSTRUCTIONS**

**This warning symbol means danger. You are in a situation that could cause bodily injury. Before you work on any equipment, be aware of the hazards involved with electrical circuitry and be familiar with standard practices for preventing accidents. Use the statement number provided at the end of each warning to locate its translation in the translated safety warnings that accompanied this device.**

#### **SAVE THESE INSTRUCTIONS**

**Waarschuwing**

#### **BELANGRIJKE VEILIGHEIDSINSTRUCTIES**

**Dit waarschuwingssymbool betekent gevaar. U verkeert in een situatie die lichamelijk letsel kan veroorzaken. Voordat u aan enige apparatuur gaat werken, dient u zich bewust te zijn van de bij elektrische schakelingen betrokken risico's en dient u op de hoogte te zijn van de standaard praktijken om ongelukken te voorkomen. Gebruik het nummer van de verklaring onderaan de waarschuwing als u een vertaling van de waarschuwing die bij het apparaat wordt geleverd, wilt raadplegen.**

#### **BEWAAR DEZE INSTRUCTIES**

<b>Varoitus</b>	<p><b>TÄRKEITÄ TURVALLISUUSOHJEITA</b></p> <p>Tämä varoitusmerkki merkitsee vaaraa. Tilanne voi aiheuttaa ruumiillisia vammoja. Ennen kuin käsittelet laitteistoa, huomioi sähköpiirien käsittelemiseen liittyvät riskit ja tutustu onnettomuuksien yleisiin ehkäisytapoihin. Turvallisuusvaroitusten käännökset löytyvät laitteen mukana toimitettujen käännettyjen turvallisuusvaroitusten joukosta varoitusten lopussa näkyvien lausuntonumeroiden avulla.</p> <p><b>SÄILYTÄ NÄMÄ OHJEET</b></p>
<b>Attention</b>	<p><b>IMPORTANTES INFORMATIONS DE SÉCURITÉ</b></p> <p>Ce symbole d'avertissement indique un danger. Vous vous trouvez dans une situation pouvant entraîner des blessures ou des dommages corporels. Avant de travailler sur un équipement, soyez conscient des dangers liés aux circuits électriques et familiarisez-vous avec les procédures couramment utilisées pour éviter les accidents. Pour prendre connaissance des traductions des avertissements figurant dans les consignes de sécurité traduites qui accompagnent cet appareil, référez-vous au numéro de l'instruction situé à la fin de chaque avertissement.</p> <p><b>CONSERVEZ CES INFORMATIONS</b></p>
<b>Warnung</b>	<p><b>WICHTIGE SICHERHEITSHINWEISE</b></p> <p>Dieses Warnsymbol bedeutet Gefahr. Sie befinden sich in einer Situation, die zu Verletzungen führen kann. Machen Sie sich vor der Arbeit mit Geräten mit den Gefahren elektrischer Schaltungen und den üblichen Verfahren zur Vorbeugung vor Unfällen vertraut. Suchen Sie mit der am Ende jeder Warnung angegebenen Anweisungsnummer nach der jeweiligen Übersetzung in den übersetzten Sicherheitshinweisen, die zusammen mit diesem Gerät ausgeliefert wurden.</p> <p><b>BEWAHREN SIE DIESE HINWEISE GUT AUF.</b></p>
<b>Avvertenza</b>	<p><b>IMPORTANTI ISTRUZIONI SULLA SICUREZZA</b></p> <p>Questo simbolo di avvertenza indica un pericolo. La situazione potrebbe causare infortuni alle persone. Prima di intervenire su qualsiasi apparecchiatura, occorre essere al corrente dei pericoli relativi ai circuiti elettrici e conoscere le procedure standard per la prevenzione di incidenti. Utilizzare il numero di istruzione presente alla fine di ciascuna avvertenza per individuare le traduzioni delle avvertenze riportate in questo documento.</p> <p><b>CONSERVARE QUESTE ISTRUZIONI</b></p>
<b>Advarsel</b>	<p><b>VIKTIGE SIKKERHETSINSTRUKSJONER</b></p> <p>Dette advarselssymbolet betyr fare. Du er i en situasjon som kan føre til skade på person. Før du begynner å arbeide med noe av utstyret, må du være oppmerksom på farene forbundet med elektriske kretser, og kjenne til standardprosedyrer for å forhindre ulykker. Bruk nummeret i slutten av hver advarsel for å finne oversettelsen i de oversatte sikkerhetsadvarslene som fulgte med denne enheten.</p> <p><b>TA VARE PÅ DISSE INSTRUKSJONENE</b></p>

**Aviso INSTRUÇÕES IMPORTANTES DE SEGURANÇA**

Este símbolo de aviso significa perigo. Você está em uma situação que poderá ser causadora de lesões corporais. Antes de iniciar a utilização de qualquer equipamento, tenha conhecimento dos perigos envolvidos no manuseio de circuitos elétricos e familiarize-se com as práticas habituais de prevenção de acidentes. Utilize o número da instrução fornecido ao final de cada aviso para localizar sua tradução nos avisos de segurança traduzidos que acompanham este dispositivo.

**GUARDE ESTAS INSTRUÇÕES****¡Advertencia! INSTRUCCIONES IMPORTANTES DE SEGURIDAD**

Este símbolo de aviso indica peligro. Existe riesgo para su integridad física. Antes de manipular cualquier equipo, considere los riesgos de la corriente eléctrica y familiarícese con los procedimientos estándar de prevención de accidentes. Al final de cada advertencia encontrará el número que le ayudará a encontrar el texto traducido en el apartado de traducciones que acompaña a este dispositivo.

**GUARDE ESTAS INSTRUCCIONES****Varning! VIKTIGA SÄKERHETSANVISNINGAR**

Denna varningssignal signalerar fara. Du befinner dig i en situation som kan leda till personskada. Innan du utför arbete på någon utrustning måste du vara medveten om farorna med elkretsar och känna till vanliga förfaranden för att förebygga olyckor. Använd det nummer som finns i slutet av varje varning för att hitta dess översättning i de översatta säkerhetsvarningar som medföljer denna anordning.

**SPARA DESSA ANVISNINGAR****Figyelem FONTOS BIZTONSÁGI ELOÍRÁSOK**

Ez a figyelmeztető jel veszélyre utal. Sérülésveszélyt rejte helyzetben van. Mielőtt bármely berendezésen munkát végezte, legyen figyelemmel az elektromos áramkörök okozta kockázatokra, és ismerkedjen meg a szokásos balesetvédelmi eljárásokkal. A kiadványban szereplő figyelmeztetések fordítása a készülékhez mellékelt biztonsági figyelmeztetések között található; a fordítás az egyes figyelmeztetések végén látható szám alapján kereshető meg.

**ORIZZE MEG EZEKET AZ UTASÍTÁSOKAT!****Предупреждение ВАЖНЫЕ ИНСТРУКЦИИ ПО СОБЛЮДЕНИЮ ТЕХНИКИ БЕЗОПАСНОСТИ**

Этот символ предупреждения обозначает опасность. То есть имеет место ситуация, в которой следует опасаться телесных повреждений. Перед эксплуатацией оборудования выясните, каким опасностям может подвергаться пользователь при использовании электрических цепей, и ознакомьтесь с правилами техники безопасности для предотвращения возможных несчастных случаев. Воспользуйтесь номером заявления, приведенным в конце каждого предупреждения, чтобы найти его переведенный вариант в переводе предупреждений по безопасности, прилагаемом к данному устройству.

**СОХРАНИТЕ ЭТИ ИНСТРУКЦИИ**

**警告** 重要的安全性说明

此警告符号代表危险。您正处于可能受到严重伤害的工作环境中。在您使用设备开始工作之前，必须充分意识到触电的危险，并熟练掌握防止事故发生的标准工作程序。请根据每项警告结尾提供的声明号码来找到此设备的安全性警告说明的翻译文本。

请保存这些安全性说明

**警告** 安全上の重要な注意事項

「危険」の意味です。人身事故を予防するための注意事項が記述されています。装置の取り扱い作業を行うときは、電気回路の危険性に注意し、一般的な事故防止策に留意してください。警告の各国語版は、各注意事項の番号を基に、装置に付属の「Translated Safety Warnings」を参照してください。

これらの注意事項を保管しておいてください。

**주의** 重要 안전 지침

이 경고 기호는 위험을 나타냅니다. 작업자가 신체 부상을 일으킬 수 있는 위험한 환경에 있습니다. 장비에 작업을 수행하기 전에 전기 회로와 관련된 위험을 숙지하고 표준 작업 관례를 숙지하여 사고를 방지하십시오. 각 경고의 마지막 부분에 있는 경고문 번호를 참조하여 이 장치와 함께 제공되는 번역된 안전 경고문에서 해당 번역문을 찾으십시오.

이 지시 사항을 보관하십시오.

**Aviso** **INSTRUÇÕES IMPORTANTES DE SEGURANÇA**

**Este símbolo de aviso significa perigo. Você se encontra em uma situação em que há risco de lesões corporais. Antes de trabalhar com qualquer equipamento, esteja ciente dos riscos que envolvem os circuitos elétricos e familiarize-se com as práticas padrão de prevenção de acidentes. Use o número da declaração fornecido ao final de cada aviso para localizar sua tradução nos avisos de segurança traduzidos que acompanham o dispositivo.**

**GUARDE ESTAS INSTRUÇÕES****Advarsel** **VIGTIGE SIKKERHEDSANVISNINGER**

**Dette advarselssymbol betyder fare. Du befinder dig i en situation med risiko for legemeskade. Før du begynder arbejde på udstyr, skal du være opmærksom på de involverede risici, der er ved elektriske kredsløb, og du skal sætte dig ind i standardprocedurer til undgåelse af ulykker. Brug erklæringsnummeret efter hver advarsel for at finde oversættelsen i de oversatte advarsler, der fulgte med denne enhed.**

**GEM DISSE ANVISNINGER****تحذير****إرشادات الأمان الهامة**

يوضح رمز التحذير هذا وجود خطر. وهذا يعني أنك متواجد في مكان قد ينتج عنه التعرض لإصابات. قبل بدء العمل، احذر مخاطر التعرض للصدمات الكهربائية وكن على علم بالإجراءات القياسية للحيلولة دون وقوع أي حوادث. استخدم رقم البيان الموجود في أحر كل تحذير لتحديد مكان ترجمته داخل تحذيرات الأمان المترجمة التي تأتي مع الجهاز. قم بحفظ هذه الإرشادات

**Upozorenje VAŽNE SIGURNOSNE NAPOMENE**

Ovaj simbol upozorenja predstavlja opasnost. Nalazite se u situaciji koja može prouzročiti tjelesne ozljede. Prije rada s bilo kojim uređajem, morate razumjeti opasnosti vezane uz električne sklopove, te biti upoznati sa standardnim načinima izbjegavanja nesreća. U prevedenim sigurnosnim upozorenjima, priloženima uz uređaj, možete prema broju koji se nalazi uz pojedino upozorenje pronaći i njegov prijevod.

**SAČUVAJTE OVE UPUTE**

**Upozornění DŮLEŽITÉ BEZPEČNOSTNÍ POKYNY**

Tento upozorňující symbol označuje nebezpečí. Jste v situaci, která by mohla způsobit nebezpečí úrazu. Před prací na jakémkoliv vybavení si uvědomte nebezpečí související s elektrickými obvody a seznamte se se standardními opatřeními pro předcházení úrazům. Podle čísla na konci každého upozornění vyhledejte jeho překlad v přeložených bezpečnostních upozorněních, která jsou přiložena k zařízení.

**USCHOVEJTE TYTO POKYNY**

**Προειδοποίηση ΣΗΜΑΝΤΙΚΕΣ ΟΔΗΓΙΕΣ ΑΣΦΑΛΕΙΑΣ**

Αυτό το προειδοποιητικό σύμβολο σημαίνει κίνδυνο. Βρίσκεστε σε κατάσταση που μπορεί να προκαλέσει τραυματισμό. Πριν εργαστείτε σε οποιοδήποτε εξοπλισμό, να έχετε υπόψη σας τους κινδύνους που σχετίζονται με τα ηλεκτρικά κυκλώματα και να έχετε εξοικειωθεί με τις συνήθεις πρακτικές για την αποφυγή ατυχημάτων. Χρησιμοποιήστε τον αριθμό δήλωσης που παρέχεται στο τέλος κάθε προειδοποίησης, για να εντοπίσετε τη μετάφρασή της στις μεταφρασμένες προειδοποιήσεις ασφαλείας που συνοδεύουν τη συσκευή.

**ΦΥΛΑΞΤΕ ΑΥΤΕΣ ΤΙΣ ΟΔΗΓΙΕΣ**

## אזהרה

## הוראות בטיחות חשובות

סימן אזהרה זה מסמל סכנה. אתה נמצא במצב העלול לגרום לפציעה. לפני שתעבוד עם ציוד כלשהו, עליך להיות מודע לסכנות הכרוכות במעגלים חשמליים ולהכיר את הנהלים המקובלים למניעת תאונות. השתמש במספר ההוראה המסופק בסופה של כל אזהרה כדי לאתר את התרגום באזהרות הבטיחות המתורגמות שמצורפות להתקן.

## שמור הוראות אלה

## Opomena

## ВАЖНИ БЕЗБЕДНОСНИ НАПАТСТВИЈА

Симболот за предупредување значи опасност. Се наоѓате во ситуација што може да предизвика телесни повреди. Пред да работите со опремата, бидете свесни за ризикот што постои кај електричните кола и треба да ги познавате стандардните постапки за спречување на несреќни случаи. Искористете го бројот на изјавата што се наоѓа на крајот на секое предупредување за да го најдете неговиот период во преведените безбедносни предупредувања што се испорачани со уредот.  
ЧУВАЈТЕ ГИ ОБИЕ НАПАТСТВИЈА

## Ostrzeżenie

## WAŻNE INSTRUKCJE DOTYCZĄCE BEZPIECZEŃSTWA

Ten symbol ostrzeżenia oznacza niebezpieczeństwo. Zachodzi sytuacja, która może powodować obrażenia ciała. Przed przystąpieniem do prac przy urządzeniach należy zapoznać się z zagrożeniami związanymi z układami elektrycznymi oraz ze standardowymi środkami zapobiegania wypadkom. Na końcu każdego ostrzeżenia podano numer, na podstawie którego można odszukać tłumaczenie tego ostrzeżenia w dołączonym do urządzenia dokumencie z tłumaczeniami ostrzeżeń.

## NINIEJSZE INSTRUKCJE NALEŻY ZACHOWAĆ

## Upozornenie

## DÔLEŽITÉ BEZPEČNOSTNÉ POKYNY

Tento varovný symbol označuje nebezpečenstvo. Nachádzate sa v situácii s nebezpečenstvom úrazu. Pred prácou na akomkoľvek vybavení si uvedomte nebezpečenstvo súvisiace s elektrickými obvodmi a oboznámte sa so štandardnými opatreniami na predchádzanie úrazom. Podľa čísla na konci každého upozornenia vyhľadajte jeho preklad v preložených bezpečnostných upozorneniach, ktoré sú priložené k zariadeniu.

## USCHOVAJTE SI TENTO NÁVOD

# Installing the SP Bootflash Memory Upgrade Kit

The SP memory upgrade procedure is divided into the following tasks:

- [Verifying the SP ROMMON Version, page 8](#)
- [Upgrading and Verifying the SP ROMMON Image, page 8](#)
- [Removing the Supervisor Engine 720, page 10](#)
- [Installing the CompactFlash Adapter, page 13](#)
- [Reinstalling the Supervisor Engine 720, page 16](#)

## Verifying the SP ROMMON Version

An SP ROMMON upgrade may be required to support the CompactFlash adapter; you must determine what SP ROMMON release is installed on the Supervisor Engine 720 prior to performing an SP ROMMON upgrade. The minimum SP ROMMON release required is 8.4(2). To determine the currently running SP ROMMON release, enter the **remote command switch show version | include ROM** command

If your system is running SP ROMMON Release 8.4(2) or a later release, you can continue on to [“Removing the Supervisor Engine 720” section on page 10](#). If your SP ROMMON release is earlier than 8.4(2), you must upgrade the SP ROMMON image. Go to the [“Upgrading and Verifying the SP ROMMON Image” section on page 8](#).

## Upgrading and Verifying the SP ROMMON Image

In order to utilize the SP CompactFlash adapter, your Supervisor Engine 720 must have SP ROMMON Release 8.4(2) or a later release installed on it.

**Note**

The upgrade task description is based on the Supervisor Engine 720 installed in a 9-slot chassis currently running ROMMON from its S (Gold) region; the ROMMON upgrade to support the CompactFlash adapter will be done in the F1 region.



To upgrade your SP ROMMON, perform these steps:

**Step 1** Download the latest SP ROMMON (c6ksup3-rm2.srec.8.4.2) from [cisco.com](http://www.cisco.com) and copy it to any of the following locations: sup-bootflash:, bootflash:, disk0:, or disk1: by entering this URL:

<http://www.cisco.com/cgi-bin/tablebuild.pl/cat6000-rommon>

**Step 2** Display the SP ROMMON image status by entering the **show rom-monitor slot 5 sp** command



**Note** The system responds with a message indicating that SP is: “Currently running ROMMON from the S (Gold) region.”

**Step 3** Verify that the necessary SP ROMMON version is present by entering the **dir {sup-bootflash:|bootflash:|disk 0:|disk 1:}** command.

**Step 4** Upgrade the SP ROMMON image by entering the **upgrade rom-monitor slot 5 sp file {sup-bootflash:|bootflash:|disk 0:|disk 1:} c6ksup3-rm2.srec.8.4.2** command.



**Note** Slot 5 indicates the slot number of the supervisor engine to be upgraded; the supervisor engine can be installed in either slot 5, slot 6, or in both slots.

Reload the switch by entering the **reload** command. At the prompt, type **Y** to confirm and press **Enter**.



**Note** Do not perform a Reset.

**Step 5** Boot the Cisco IOS software from the boot device. At this point the SP ROMMON upgrade process is complete; the next steps are used to verify that the upgrade has been completed correctly.

**Step 6** Enter privileged EXEC mode by entering the **enable** command

**Step 7** Display the SP ROMMON image status by entering the **show rom-monitor slot 5 sp**



**Note** The system responds with a message indicating that SP is “Currently running ROMMON from F1 region.”

**Step 8** Verify the SP ROMMON version by entering the **remote command switch show version | include ROM** command.



**Note** You should see “ROM: System Bootstrap, Version 8.4(2).”

## Removing the Supervisor Engine 720



### Warning

**Only trained and qualified personnel should be allowed to install, replace, or service this equipment.** Statement 1030

The following tools are required to perform the bootflash upgrade kit installation:

- 3/16-inch flat-blade screwdriver for the captive installation screws on the supervisor engine
- Antistatic mat or foam pad to support and protect the removed supervisor engine
- Your own ESD-prevention equipment or the disposable grounding wrist strap included with all upgrade kits, field-replaceable units (FRUs), and spares



### Warning

**Blank faceplates and cover panels serve three important functions: they prevent exposure to hazardous voltages and currents inside the chassis; they contain electromagnetic interference (EMI) that might disrupt other equipment; and they direct the flow of cooling air through the chassis. Do not operate the system unless all cards, faceplates, front covers, and rear covers are in place.** Statement 1029



### Warning

**Hazardous voltage or energy is present on the backplane when the system is operating. Use caution when servicing.** Statement 1034



### Caution

Always use an ESD wrist strap when handling the Supervisor Engine 720 or coming in contact with internal components.

To remove the supervisor engine, follow these steps:

- Step 1** Power down your system.
- Step 2** Disconnect any network interface cables attached to the supervisor engine.
- Step 3** Attach an ESD grounding strap to your wrist and to ground. (If you are unsure about the correct way to attach an ESD grounding strap, see the [“Attaching Your ESD Grounding Strap”](#) section on page 24 for instructions.)
- Step 4** Verify that the captive installation screws on all of the modules in the chassis are tight. This step ensures that the space created by the removed module is maintained.



### Note

If the captive installation screws are loose, the EMI gaskets on the installed modules will push the modules toward the open slot, reducing the opening size and making it difficult to reinstall the module.

- Step 5** Loosen the two captive screws on the supervisor engine that is to be removed.

**Step 6** Depending on the orientation of the slots in the chassis (horizontal or vertical), perform one of the following two sets of steps:

**Horizontal slots**

- a. Place your thumbs on the left and right ejector levers, and simultaneously rotate the levers outward to unseat the supervisor engine from the backplane connector. (See [Figure 2.](#))
- b. Grasp the front edge of the supervisor engine, and slide the supervisor engine partially out of the slot. Place your other hand under the supervisor engine to support the weight of the module. Do not touch the module circuitry. (See [Figure 3.](#))

**Vertical slots**

- a. Place your thumbs on the ejector levers located at the top and bottom of the supervisor engine, and simultaneously rotate the levers outward to unseat the supervisor engine from the backplane connector.
- b. Grasp the edges of the supervisor engine, and slide the supervisor engine straight out of the slot. Do not touch the module circuitry.

**Step 7** Immediately place the supervisor engine on an antistatic mat or antistatic foam.

Figure 2 Opening the Ejector Levers (Horizontal Chassis Shown)

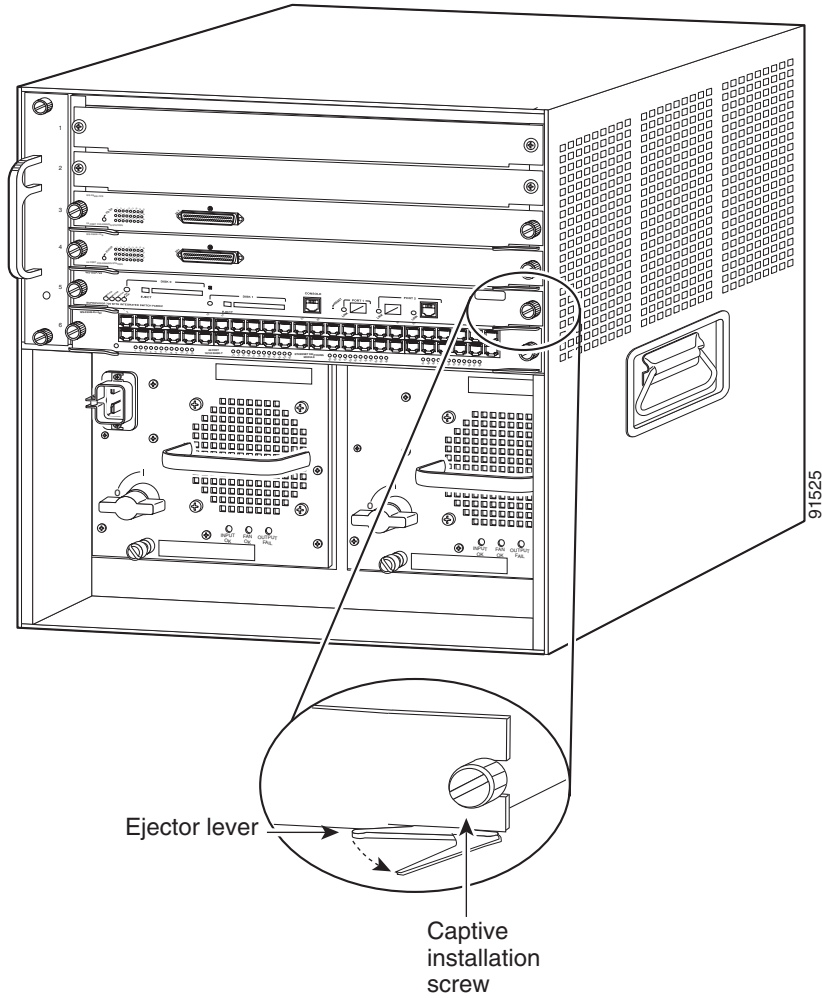

**Figure 3** Removing the Module from the Chassis (Horizontal Chassis Shown)

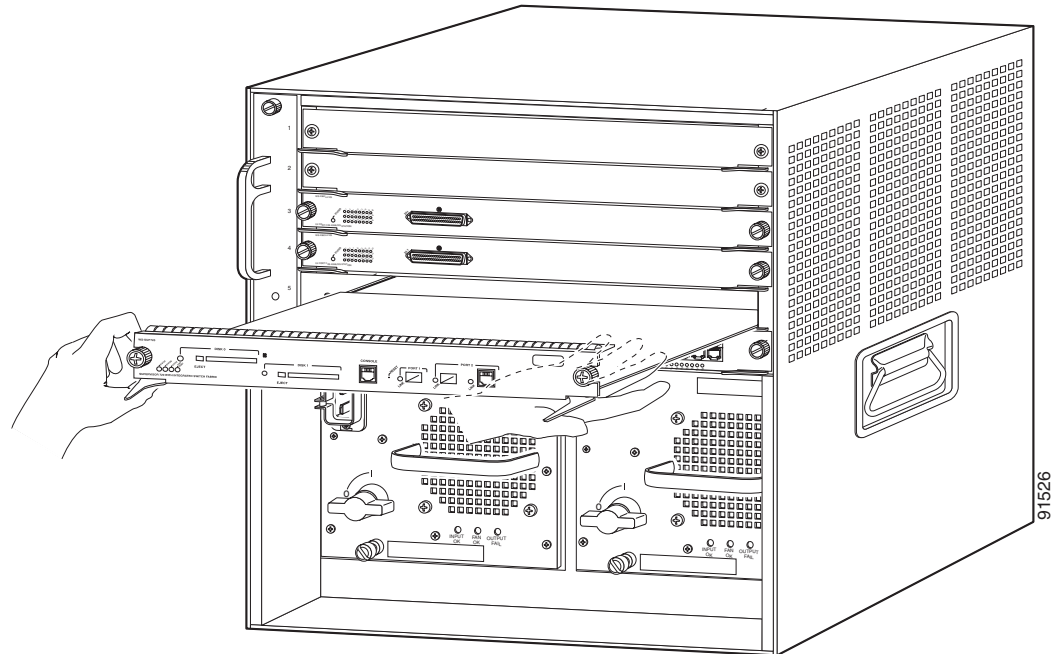

## Installing the CompactFlash Adapter

To install the CompactFlash adapter, follow these steps:

- Step 1** Locate the SP BOOTFLASH DIMM socket on the Supervisor Engine 720. (See [Figure 4](#).) The SP BOOTFLASH DIMM is on the left side of the Supervisor Engine 720 as you face the front of the board; the RP BOOTFLASH DIMM is on the right side of the Supervisor Engine 720 as you face the front of the board.



**Note** The DIMM is a sensitive component that is susceptible to ESD damage. To prevent ESD damage, wear an ESD grounding wrist strap and handle the DIMM by the edges only; avoid touching the memory modules, pins, or traces (including the metal *fingers* along the connector edge of the DIMM). Attach an ESD grounding strap to your wrist and to ground. (If you are unsure about the correct way to attach an ESD grounding strap, see the [“Attaching Your ESD Grounding Strap”](#) section on page 24 for instructions.)

**Figure 4** *SP and RP DIMM Locations on the Supervisor Engine 720*

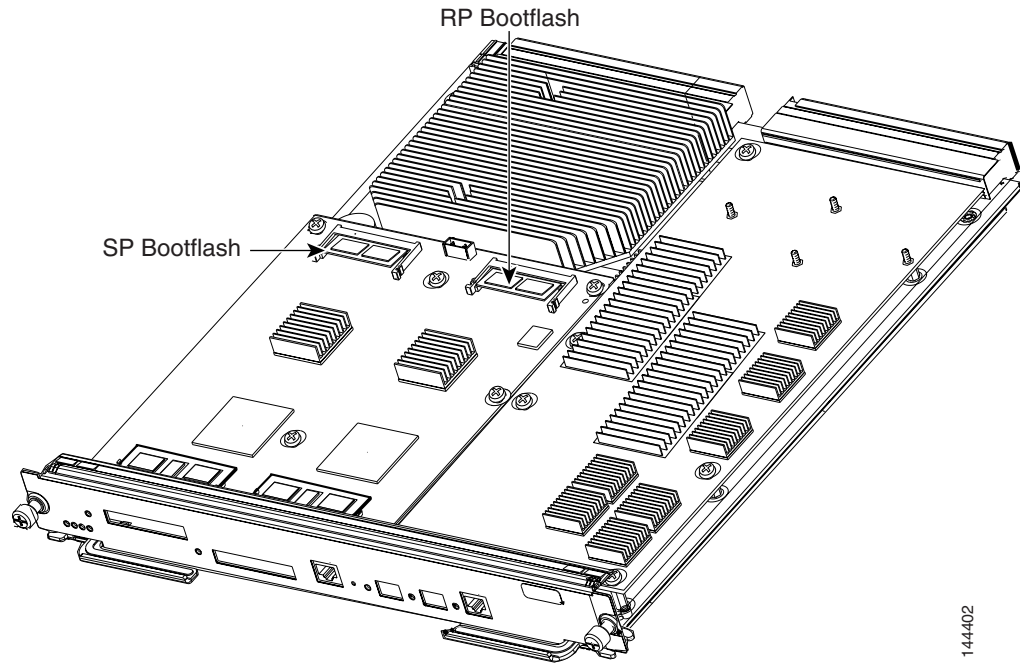

- Step 2** Release the SP DIMM from the socket by simultaneously releasing the two locking spring clip tabs on either side of the DIMM socket. (See [Figure 5](#), left view.) The DIMM will flip up in the socket. (See [Figure 5](#), right view.)
- Step 3** Hold the DIMM by its edges and carefully remove it from the DIMM socket.

**Figure 5** *Removing the DIMM*

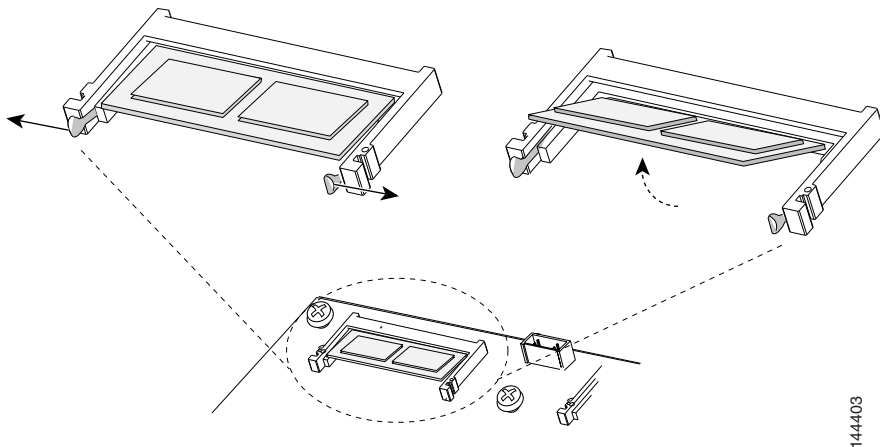

- Step 4** Immediately place the DIMM in an antistatic bag.

**Step 5** Open the antistatic bag containing the SP CompactFlash adapter.



**Note** The SP CompactFlash adapter has a label attached to the CompactFlash identifying it as the SP CompactFlash adapter.

**Step 6** Carefully align the CompactFlash adapter edge connector with the DIMM socket. Slide the CompactFlash adapter edge connector at an angle into the socket. (See [Figure 6](#).)



**Note** Make sure that the CompactFlash adapter edge connector is fully inserted into the DIMM socket.

**Step 7** Press down firmly on both edges of the CompactFlash adapter until the CompactFlash adapter latches into place. Visually verify that both locking spring clips are fully engaged over the edges of the CompactFlash adapter. (See [Figure 6](#).)

**Figure 6** *Installing the CompactFlash Adapter*

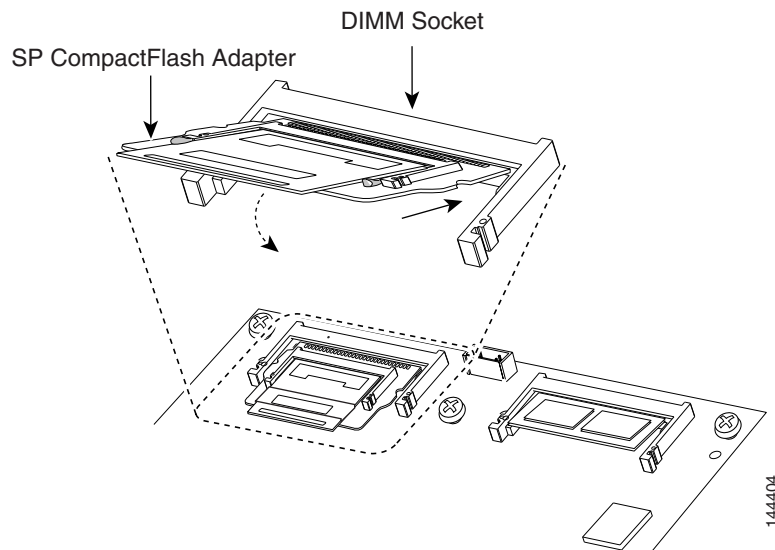

You are now ready to reinstall the Supervisor Engine 720 into the switch chassis.

## Reinstalling the Supervisor Engine 720

**Caution**

During this procedure, wear grounding wrist straps and handle modules by the carrier edges only to avoid ESD damage to the card.

To reinstall the Supervisor Engine 720 in the chassis, follow these steps:

**Step 1** Attach an ESD grounding strap to your wrist and to ground. (If you are unsure about the correct way to attach an ESD grounding strap, see the [“Attaching Your ESD Grounding Strap”](#) section on page 24 for instructions.)

**Step 2** Verify that the captive installation screws are tightened on all modules installed in the chassis. This action assures that the EMI gaskets on all modules are fully compressed in order to maximize the opening space for the removed module.

**Note**

If the captive installation screws are loose, the EMI gaskets on the installed modules will push adjacent modules toward the open slot, reducing the opening size and making it difficult to install the removed module.

**Step 3** Fully open both ejector levers on the supervisor engine that is being installed. (See [Figure 7](#).)



**Figure 7 Positioning the Module in a Horizontal Slot Chassis**

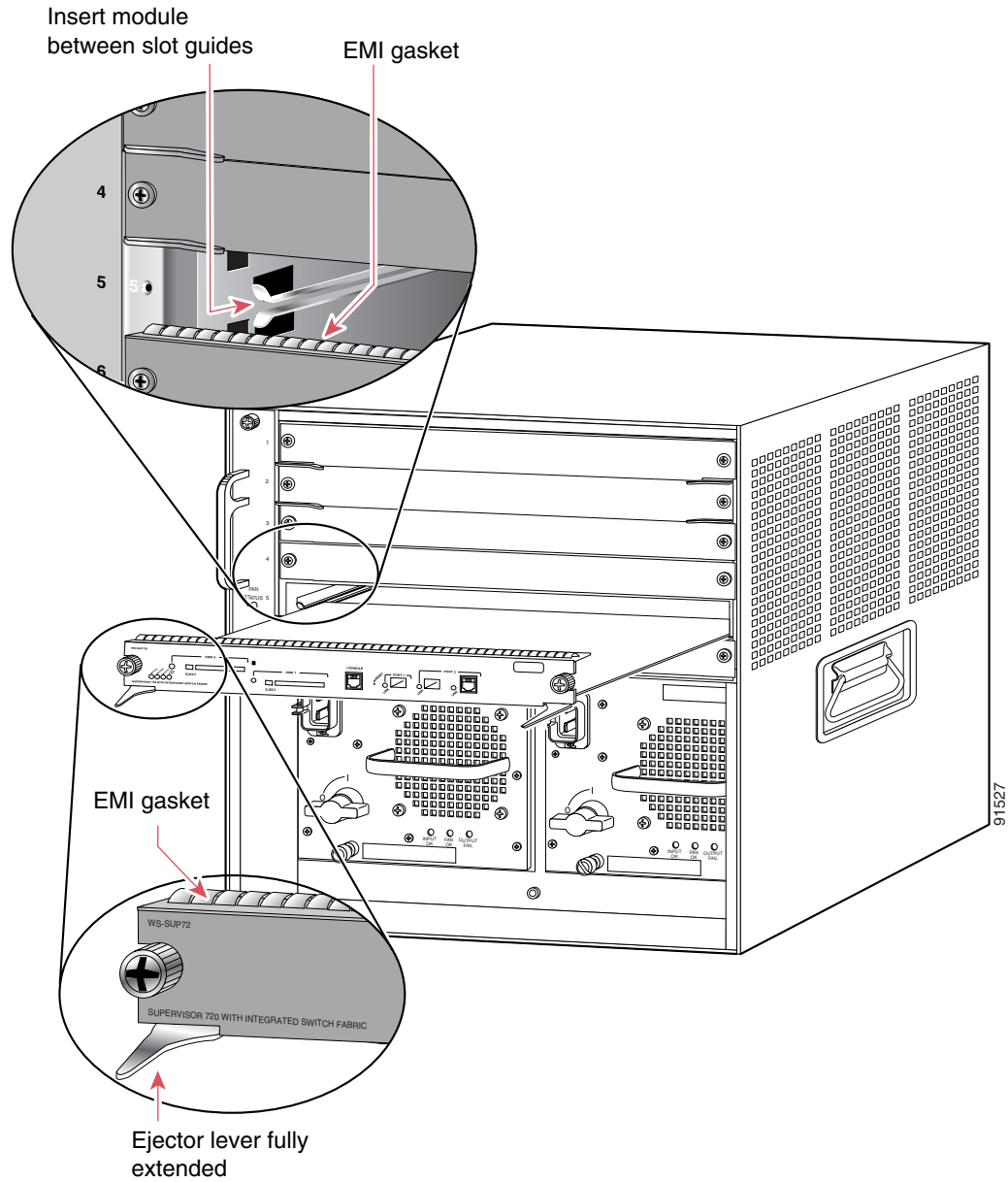

- Step 4** Depending on the orientation of the slots in the chassis (horizontal or vertical), perform one of the following two sets of steps:

#### Horizontal slots

- a. Position the supervisor engine in the slot. (See [Figure 7](#).) Make sure that you align the sides of the module carrier with the slot guides on each side of the slot.
- b. Carefully slide the supervisor engine into the slot until the EMI gasket along the top edge of the module makes contact with the module in the slot above it and both ejector levers have closed to approximately 45 degrees with respect to the module faceplate. (See [Figure 8](#).)
- c. Using the thumb and forefinger of each hand, grasp the two ejector levers and press down to create a small 0.040 inch (1 mm) gap between the supervisor engine's EMI gasket and the module above it. (See [Figure 8](#).)



---

**Note** Do not press down too forcefully on the levers because they will bend and be damaged.

---

- d. While pressing down, simultaneously close the left and right ejector levers to fully seat the supervisor engine in the backplane connector. The ejector levers are fully closed when they are flush with the module faceplate. (See [Figure 8](#).)



---

**Note** Failure to fully seat the module in the backplane connector can result in error messages.

---

- e. Tighten the two captive installation screws on the supervisor engine.



---

**Note** Make sure that the ejector levers are fully closed before tightening the captive installation screws.

---

- f. Power up your system.





---

**Note** Depending on how your system bootstring is configured, your system might stay in ROMMON. To boot the system from the CF adapter, enter the **boot bootdisk:** command. Once you install the CF adapter, you must define the Cisco IOS bootstring as **boot system flash sup-bootdisk:[image name]**. With SP ROMMON Release 8.4(2), the bootstring has to be defined as sup-bootdisk:. SP ROMMON releases later than 8.4(2) only accept the bootstring defined as sup-bootflash:.

---

- g. Verify that the Supervisor Engine 720 STATUS LED is lit. Periodically check the STATUS LED. If the STATUS LED changes from orange to green, the module has successfully completed the boot process and is now online. If the STATUS LED remains orange or turns red, the supervisor engine has not successfully completed the boot process and may have encountered an error.

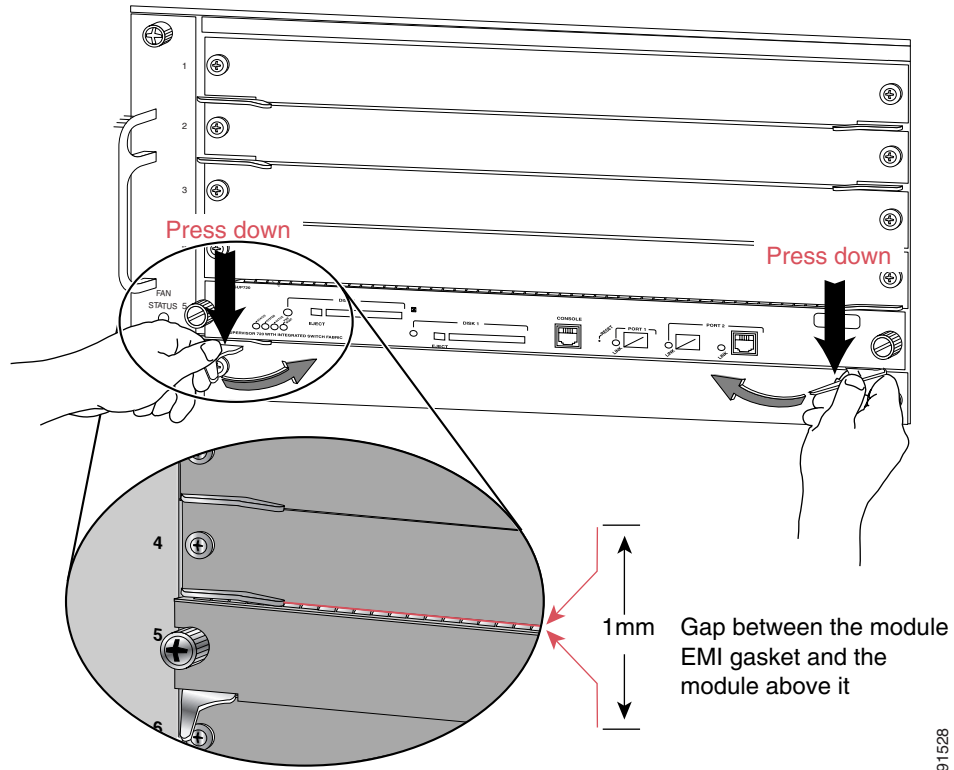
**Figure 8** Clearing the EMI Gasket in a Horizontal Slot Chassis



**Vertical slots**

- a. Position the supervisor engine in the slot. (See [Figure 9](#).) Make sure that you align the sides of the module carrier with the slot guides on the top and bottom of the slot.
- b. Carefully slide the supervisor engine into the slot until the EMI gasket along the right edge of the module makes contact with the module in the slot adjacent to it and both ejector levers have closed to approximately 45 degrees with respect to the module faceplate. (See [Figure 10](#).)

**Figure 9** Positioning the Module in a Vertical Slot Chassis

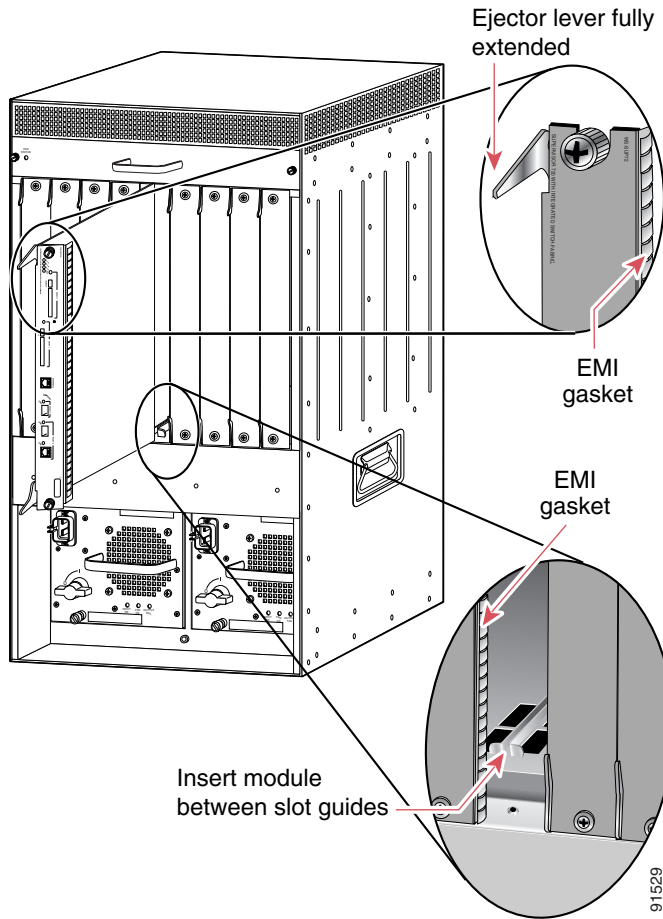

**Figure 10** Clearing the EMI Gasket in a Vertical Slot Chassis

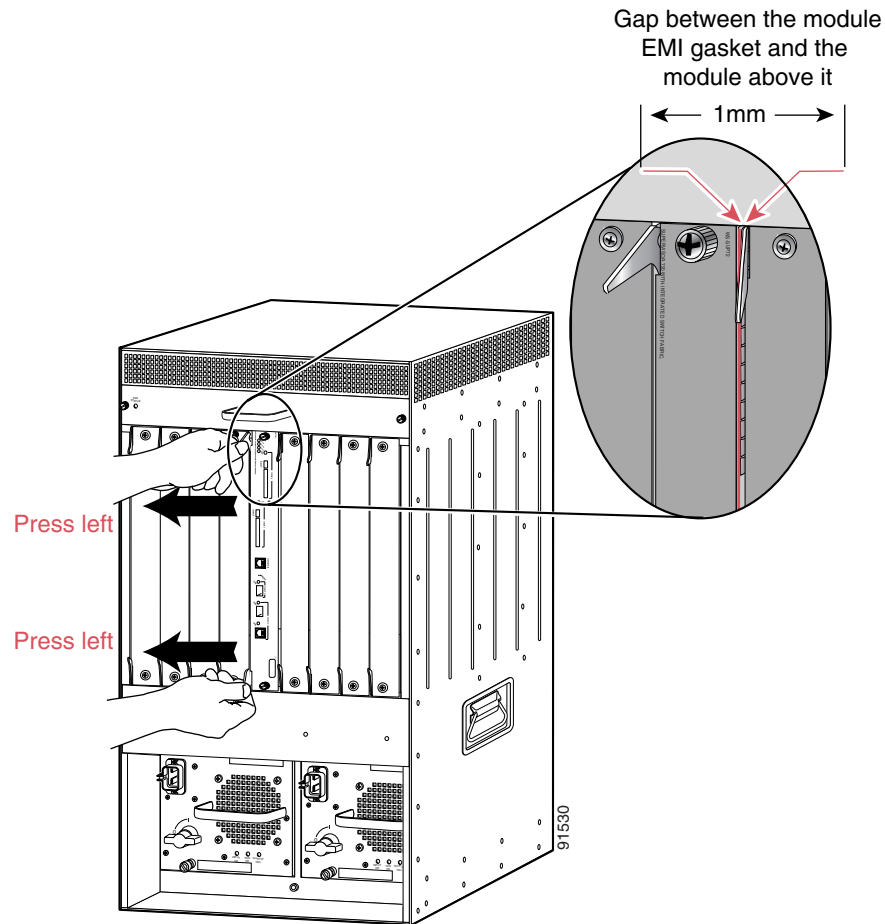

- c. Using the thumb and forefinger of each hand, grasp the two ejector levers and exert a slight pressure to the left, deflecting it approximately 0.040 inches (1 mm) creating a small gap between the supervisor engine's EMI gasket and the module adjacent to it. (See [Figure 10](#).)



**Note** Do not exert too much pressure on the ejector levers because they will bend and be damaged.

- d. While pressing down on the ejector levers, simultaneously close the levers to fully seat the supervisor engine in the backplane connector. The ejector levers are fully closed when they are flush with the module faceplate.

- e. Tighten the two captive installation screws on the supervisor engine.



**Note** Make sure that the ejector levers are fully closed before tightening the captive installation screws.

- f. Power up your system.



**Note** Depending on how your system bootstring is configured, your system might stay in ROMMON. To boot the system from the CF adapter, enter the **boot bootdisk:** command. Once you install the CF adapter, you must define the Cisco IOS bootstring as **boot system flash sup-bootdisk:[image name]**  
 With SP ROMMON Release 8.4(2), the bootstring has to be defined as sup-bootdisk:. SP ROMMON releases later than 8.4(2) only accept the bootstring defined as sup-bootflash:.

- g. Verify that the Supervisor Engine 720 STATUS LED is lit. Periodically check the STATUS LED. If the STATUS LED changes from orange to green, the module has successfully completed the boot process and is now online. If the STATUS LED remains orange or turns red, the supervisor engine has not successfully completed the boot process and may have encountered an error.

## Removing and Installing the CompactFlash in the CompactFlash Adapter

CompactFlash is normally shipped already installed in the CompactFlash adapter. However, there might be occasions when you will need to replace a defective CompactFlash or swap an existing CompactFlash for a larger capacity device.

To remove the CompactFlash from the adapter, follow these steps:

**Step 1** Remove the Supervisor Engine 720 from the system chassis. See the [“Removing the Supervisor Engine 720” section on page 10](#).

**Step 2** Place the Supervisor Engine 720 on an antistatic mat.



**Caution** Do not remove the CompactFlash from the CompactFlash adapter while the adapter is installed in the DIMM socket; you must remove the CompactFlash adapter first.

**Step 3** Release the CompactFlash adapter from the DIMM socket by simultaneously releasing the two locking spring clips on either side of the DIMM socket. The CompactFlash adapter will flip up in the socket.

**Step 4** Hold the CompactFlash adapter by its edges and carefully remove it from the DIMM socket.

**Step 5** Holding the CompactFlash adapter in one hand as shown in [Figure 11](#), grasp the CompactFlash with your other hand (View 1) and carefully and firmly pull the CompactFlash (Views 2 and 3) to disconnect the CompactFlash from the adapter.

**Figure 11** Removing the CompactFlash from the Adapter

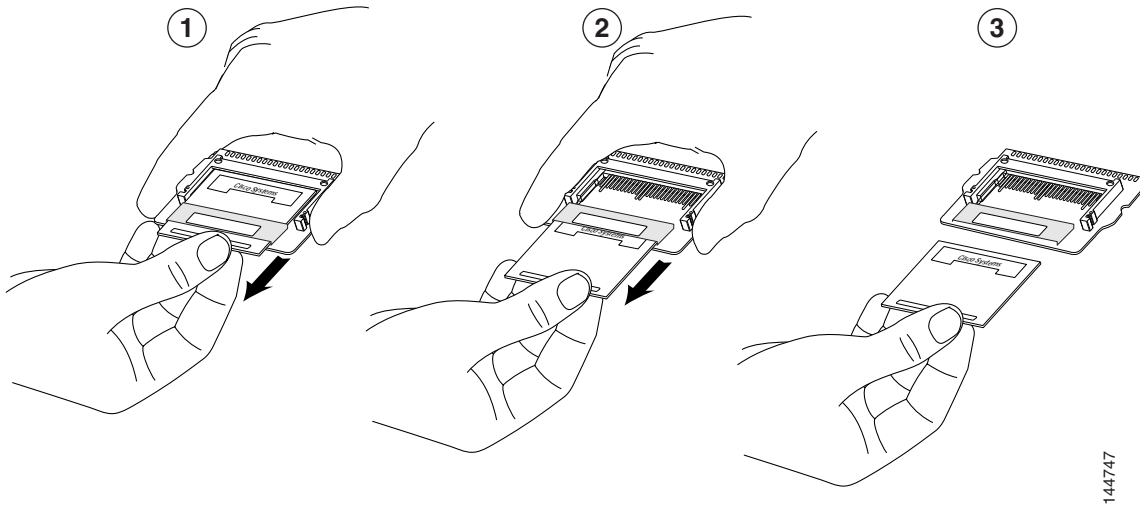

To install the CompactFlash in the adapter, follow these steps:

- Step 1** Remove the replacement CompactFlash from its packaging.
- Step 2** Grasp the empty adapter and the CompactFlash, and position the CompactFlash in front of the adapter as shown in [Figure 12](#), View 1. Align the slots in the CompactFlash with the rails in the adapter.
- Step 3** Slide the CompactFlash into the adapter until the CompactFlash is firmly seated in the adapter connector. (See [Figure 12](#), Views 2 and 3.)



**Note** To make good electrical contact, you must fully insert the adapter's connector pins into the CompactFlash; the pins should not be visible.

- Step 4** Install the CompactFlash adapter in the DIMM socket using [Step 6](#) and [Step 7](#) on Page 15.
- Step 5** Reinstall the Supervisor Engine 720 in the chassis following the “[Reinstalling the Supervisor Engine 720](#)” procedure on page 16.

Figure 12 Installing a CompactFlash in the Adapter

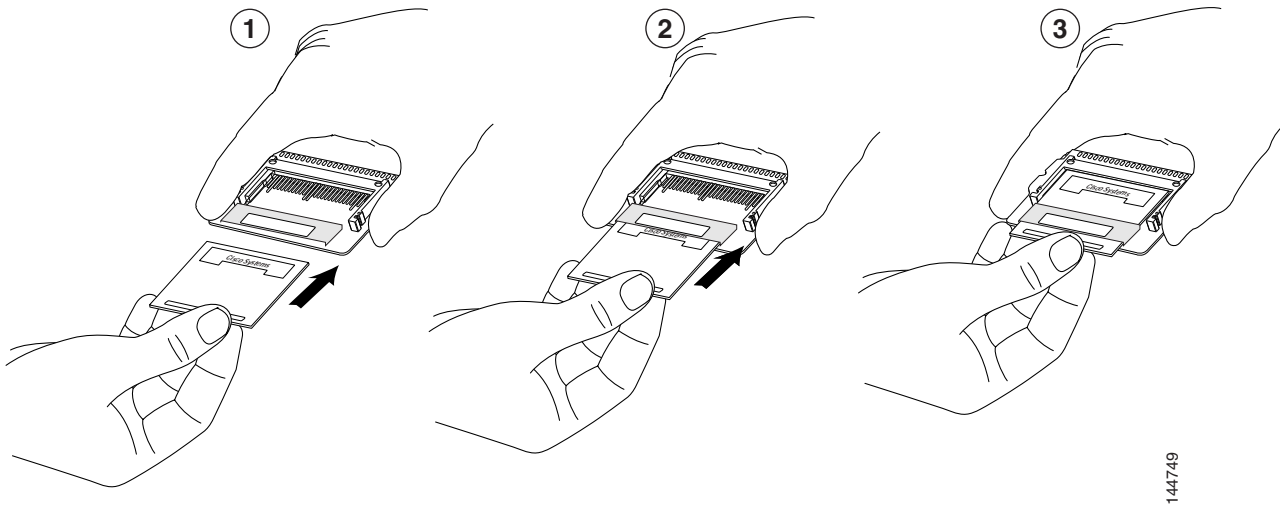

## Attaching Your ESD Grounding Strap

Electrostatic discharge (ESD) damage, which can occur when modules or other FRUs are improperly handled, results in intermittent or complete failures. Modules consist of printed circuit boards that are fixed in metal carriers. Electromagnetic interference (EMI) shielding and connectors are integral components of the carrier. Although the metal carrier helps to protect the board from ESD, always use an ESD grounding strap when handling modules.

Follow these guidelines for preventing ESD damage:

- Always use an ESD wrist strap and ensure that it makes maximum contact with bare skin. ESD grounding straps are available with banana plugs, metal spring clips, or alligator clips. All Catalyst 6500 series chassis are equipped with a banana plug connector (identified by the ground symbol next to the connector) on the front panel. If you have an older Catalyst 6500 series chassis equipped with a plastic banana plug connector, we recommend that you use either the supplied ESD grounding wrist strap (with a metal clip) or an ESD grounding wrist strap equipped with an alligator clip. If you have a newer Catalyst 6500 series chassis that has a bare metal hole as the banana plug connector (also identified by the ground symbol next to the connector), we recommend that you use a personal ESD grounding strap equipped with a banana plug.
- If you choose to use the disposable ESD wrist strap supplied with most FRUs or an ESD wrist strap equipped with an alligator clip, you must attach the system ground lug to the chassis in order to provide a proper grounding point for the ESD wrist strap.



**Note** This system ground is also referred to as the network equipment building system (NEBS) ground.

- If your chassis does not have the system ground attached, you must install the system ground lug. Refer to the online *Catalyst 6500 Series Switches Installation Guide* for the procedure.





---

**Note** You do not need to attach a supplemental system ground wire to the system ground lug; the lug provides a direct path to the bare metal of the chassis.

---

After you install the system ground lug, you can perform the procedure in this section.

To attach the ESD wrist strap, follow these steps:

- 
- Step 1** Attach the ESD wrist strap to bare skin as follows:
- a. If you are using the ESD wrist strap supplied with the FRUs, open the wrist strap package and unwrap the ESD wrist strap. Place the black conductive loop over your wrist and tighten the strap so that it makes good contact with your bare skin.
  - b. If you are using an ESD wrist strap equipped with an alligator clip, open the package and remove the ESD wrist strap. Locate the end of the wrist strap that attaches to your body and secure it to your bare skin.
- Step 2** Grasp the spring or alligator clip on the ESD wrist strap and momentarily touch the clip to a bare metal spot (unpainted surface) on the rack. We recommend that you touch the clip to an unpainted rack rail so that any built-up static charge is then safely dissipated to the entire rack.
- Step 3** Attach either the spring clip or the alligator clip to the ground lug screw as follows (see [Figure 13](#)):
- a. If you are using the ESD wrist strap that is supplied with the FRUs, squeeze the spring clip jaws open, position the spring clip to one side of the system ground lug screw head, and slide the spring clip over the lug screw head so that the spring clip jaws close behind the lug screw head.



---

**Note** The spring clip jaws do not open wide enough to fit directly over the head of the lug screw or the lug barrel.

---

- b. If you are using an ESD wrist strap that is equipped with an alligator clip, attach the alligator clip directly over the head of the system ground lug screw or to the system ground lug barrel.

**Figure 13** Attaching the ESD Wrist Strap Clip to the System Ground Lug Screw

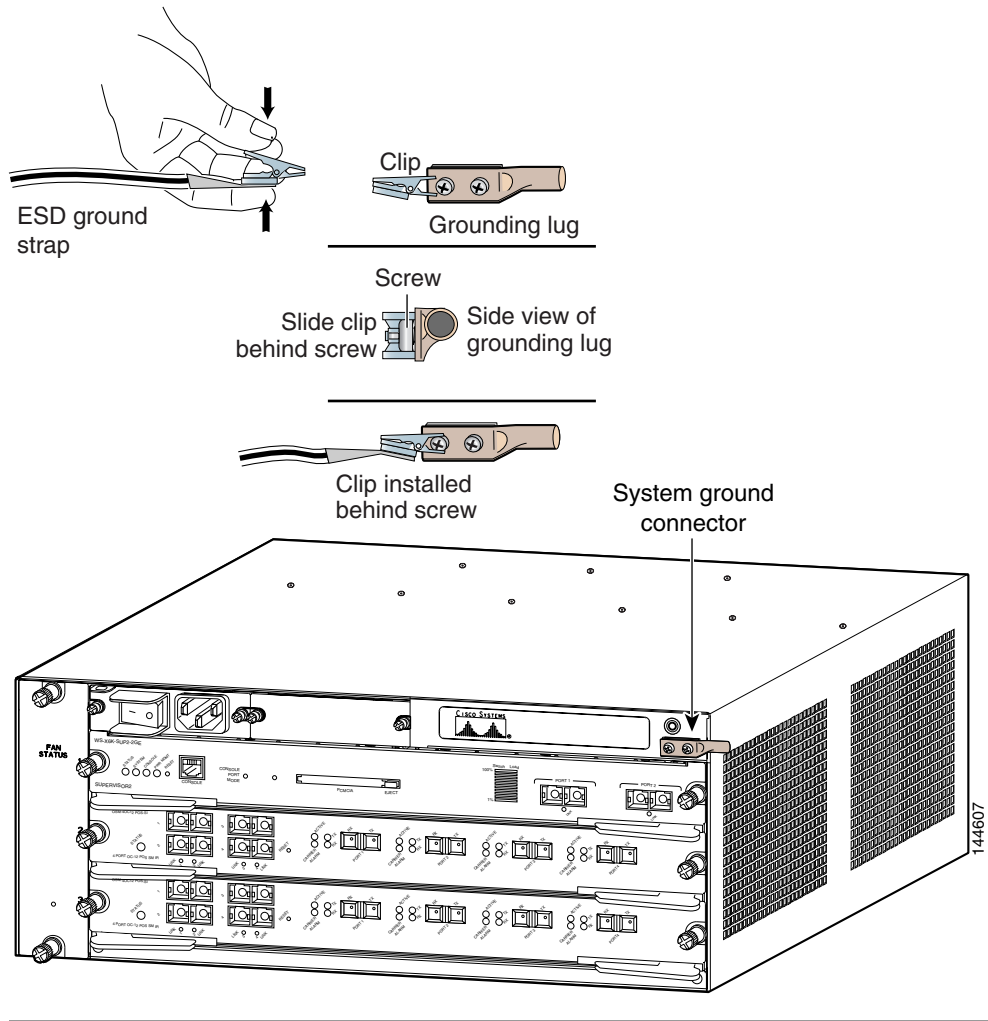

## Module Handling Guidelines

Follow these guidelines when handling modules:

- Handle carriers by available handles or edges only; avoid touching the printed circuit boards or connectors.
- Place a removed component board-side-up on an antistatic surface or in a static shielding container. If you plan to return the component to the factory, immediately place it in a static shielding container.
- Never attempt to remove the printed circuit board from the metal carrier.



**Caution**

For safety, periodically check the resistance value of the antistatic strap. The measurement should be between 1 and 10 megohm (Mohm).

# Safety Warning Translations

This section repeats in multiple languages the basic warnings that appear in this publication.

## Statement 1030—Equipment Installation



**Warning**

**Only trained and qualified personnel should be allowed to install, replace, or service this equipment.**

**Waarschuwing**

**Deze apparatuur mag alleen worden geïnstalleerd, vervangen of hersteld door bevoegd geschoold personeel.**

**Varoitus**

**Tämän laitteen saa asentaa, vaihtaa tai huoltaa ainoastaan koulutettu ja laitteen tunteva henkilökunta.**

**Attention**

**Il est vivement recommandé de confier l'installation, le remplacement et la maintenance de ces équipements à des personnels qualifiés et expérimentés.**

**Warnung**

**Das Installieren, Ersetzen oder Bedienen dieser Ausrüstung sollte nur geschultem, qualifiziertem Personal gestattet werden.**

**Avvertenza**

**Questo apparato può essere installato, sostituito o mantenuto unicamente da un personale competente.**

**Advarsel**

**Bare opplært og kvalifisert personell skal foreta installasjoner, utskiftninger eller service på dette utstyret.**

**Aviso**

**Apenas pessoal treinado e qualificado deve ser autorizado a instalar, substituir ou fazer a revisão deste equipamento.**

**¡Advertencia!**

**Solamente el personal calificado debe instalar, reemplazar o utilizar este equipo.**

**Varning!**

**Endast utbildad och kvalificerad personal bör få tillåtelse att installera, byta ut eller reparera denna utrustning.**

**Figyelem**

**A berendezést csak szakképzett személyek helyezhetik üzembe, cserélhetik és tarthatják karban.**

**Предупреждение**

**Установку, замену и обслуживание этого оборудования может осуществлять только специально обученный квалифицированный персонал.**

**警告**

**只有经过培训且具有资格的人员才能进行此设备的安装、更换和维修。**

**警告**

**この装置の設置、交換、保守は、訓練を受けた相応の資格のある人が行ってください。**

주의	교육을 받고 자격을 갖춘 사람만 이 장비를 설치, 교체, 또는 서비스를 수행해야 합니다.
Aviso	<b>Somente uma equipe treinada e qualificada tem permissão para instalar, substituir ou dar manutenção a este equipamento.</b>
Advarsel	<b>Kun uddannede personer må installere, udskifte komponenter i eller servicere dette udstyr.</b>
تحذير	يسمح للمنيين المتخصصين فقط بتركيب المعدة أو استبدالها أو إجراء الصيانة عليها.
Upozorenje	<b>Uređaj smije ugrađivati, mijenjati i servisirati samo za to obučeno i osposobljeno servisno osoblje.</b>
Upozornění	<b>Instalaci, výměnu nebo opravu tohoto zařízení smějí provádět pouze proškolené a kvalifikované osoby.</b>
Προειδοποίηση	Η τοποθέτηση, η αντικατάσταση και η συντήρηση του εξοπλισμού επιτρέπεται να γίνονται μόνο από καταρτισμένο προσωπικό με τα κατάλληλα προσόντα.
אזהרה	רק עובדים מיומנים ומוסמכים רשאים להתקין, להחליף, או לטפל בציד זה.
Орoмена	Местењето, заменувањето и сервисирањето на оваа опрема треба да му биде дозволено само на обучен и квалификуван персонал.
Ostrzeżenie	<b>Do instalacji, wymiany i serwisowania tych urządzeń mogą być dopuszczone wyłącznie osoby wykwalifikowane i przeszkolone.</b>
Upozornenie	<b>Inštaláciu, výmenu alebo opravu tohto zariadenia smú vykonávať iba vyškolené a kvalifikované osoby.</b>

## Statement 1029—Blank Faceplates and Cover Panels



### Warning

Blank faceplates and cover panels serve three important functions: they prevent exposure to hazardous voltages and currents inside the chassis; they contain electromagnetic interference (EMI) that might disrupt other equipment; and they direct the flow of cooling air through the chassis. Do not operate the system unless all cards, faceplates, front covers, and rear covers are in place.

Statement

### Waarschuwing

Legge vlakplaten en afdekpanelen vervullen drie belangrijke functies: ze voorkomen blootstelling aan gevaarlijke voltages en stroom binnenin het frame, ze bevatten elektromagnetische storing (EMI) hetgeen andere apparaten kan verstoren en ze leiden de stroom van koellucht door het frame. Het systeem niet bedienen tenzij alle kaarten, vlakplaten en afdekkingen aan de voor- en achterkant zich op hun plaats bevinden.

### Varoitus

Tyhjillä tasolaikoilla ja suoja-paneelilla on kolme tärkeää käyttötarkoitusta: Ne suojaavat asennuspohjan sisäisille vaarallisille jännitteille ja sähkövirralle altistumiselta; ne pitävät sisälläan elektromagneettisen häiriön (EMI), joka voi häiritä muita laitteita; ja ne suuntaavat tuuletusilman asennuspohjan läpi. Järjestelmää ei saa käyttää, elleivät kaikki tasolaikat, etukannet ja takakannet ole kunnolla paikoillaan.

### Attention

Ne jamais faire fonctionner le système sans que l'intégralité des cartes, des plaques métalliques et des panneaux avant et arrière ne soient fixés à leur emplacement. Ceux-ci remplissent trois fonctions essentielles : ils évitent tout risque de contact avec des tensions et des courants dangereux à l'intérieur du châssis, ils évitent toute diffusion d'interférences électromagnétiques qui pourraient perturber le fonctionnement des autres équipements, et ils canalisent le flux d'air de refroidissement dans le châssis.

### Warnung

Blanke Faceplates und Abdeckungen haben drei wichtigen Funktionen: (1) Sie schützen vor gefährlichen Spannungen und Strom innerhalb des Chassis; (2) sie halten elektromagnetische Interferenzen (EMI) zurück, die andere Geräte stören könnten; (3) sie lenken den kühlenden Luftstrom durch das Chassis. Das System darf nur betrieben werden, wenn alle Karten, Faceplates, Vorder- und Rückabdeckungen an Ort und Stelle sind.

### Avvertenza

Le piattaforme bianche e i pannelli di protezione hanno tre funzioni importanti: Evitano l'esposizione a voltaggi e correnti elettriche pericolose nello chassis, trattengono le interferenze elettromagnetiche (EMI) che potrebbero scambussolare altri apparati e dirigono il flusso di aria per il raffreddamento attraverso lo chassis. Non mettete in funzione il sistema se le schede, le piattaforme, i pannelli frontali e posteriori non sono in posizione.

### Advarsel

Blanke ytterplater og deksler sørger for tre viktige funksjoner: de forhindrer utsettelse for farlig spenning og strøm inni kabinettet; de inneholder elektromagnetisk forstyrrelse (EMI) som kan avbryte annet utstyr, og de dirigerer luftavkjølingsstrømmen gjennom kabinettet. Betjen ikke systemet med mindre alle kort, ytterplater, frontdeksler og bakdeksler sitter på plass.

### Aviso

As faces furadas e os painéis de protecção desempenham três importantes funções: previnem contra uma exposição perigosa a voltagens e correntes existentes no interior do chassis; previnem contra interferência electromagnética (EMI) que poderá danificar outro equipamento; e canalizam o fluxo do ar de refrigeração através do chassis. Não deverá operar o sistema sem que todas as placas, faces, protecções anteriores e posteriores estejam nos seus lugares.

- ¡Advertencia!** Las placas frontales y los paneles de relleno cumplen tres funciones importantes: evitan la exposición a niveles peligrosos de voltaje y corriente dentro del chasis; reducen la interferencia electromagnética (EMI) que podría perturbar la operación de otros equipos y dirigen el flujo de aire de enfriamiento a través del chasis. No haga funcionar el sistema a menos que todas las tarjetas, placas frontales, cubiertas frontales y cubiertas traseras estén en su lugar.
- Varning!** Tomma framplattor och skyddspaneler har tre viktiga funktioner: de förhindrar att personer utsätts för farlig spänning och ström som finns inuti chassit; de innehåller elektromagnetisk interferens (EMI) som kan störa annan utrustning; och de styr riktningen på kylflödet genom chassit. Använd inte systemet om inte alla kort, framplattor, fram- och bakskydd är på plats.
- Figyelem** Az előlapok és burkolópanelek három fontos funkciót töltenek be: biztosítják a veszélyes feszültségű és áramerősségű területek érintésvédelmét; elnyelik a más berendezések működésében működési zavarokat okozó elektromágneses interferenciát (EMI); a gépházon belül terelik a hűtőlevegőt. Csak úgy működtesse a rendszert, ha minden kártya, lemez, elülső és hátulsó burkolat a helyén van.
- Предупреждение** Заглушки передней панели и защитные панели выполняют три важные функции: помогают избежать поражения электротоком высокого напряжения при прикосновении к внутренним элементам, экранируют электромагнитное излучение, которое может нарушить работу другого оборудования, а также направляют охлаждающий воздушный поток внутри корпуса. Не пользуйтесь устройством со снятыми крышками, заглушками, передними и задними защитными панелями.
- 警告** 空白面板和盖板具有三个重要的功能：它们可以防止接触到底盘内危险的电压和电流；它们将可能破坏其它设备的电磁干扰 (EMI) 封闭起来；它们可以使冷气流从底盘通过。请勿在全部卡、面板、前盖和后盖未安装完毕时操作系统。
- 警告** ブランクの前面プレートおよびカバー パネルは、3つの重要な役割を果たします。シャーシ内部の危険な電圧および電流に接触しないように防御の役割を果たします。他の機器に悪影響を与えるEMI(電磁波干渉)を外に出しません。さらに、シャーシ全体に冷却用の空気を流します。カード、前面プレート、前面カバー、および背面カバーがすべて取り付けられてから、システムを稼働させてください。
- 주의** 비어있는 전면케이스 커버와 커버 패널은 다음과 같은 세가지 중요한 역할을 합니다. 쉼시 내부의 위험한 전압 및 전류에 노출되는 것을 방지, 기타 장비에 영향을 끼칠 수 있는 전자파 간섭(EMI)을 포함, 냉각 공기를 쉼시로 유입. 모든 카드, 전면케이스 커버, 전면 및 후면 커버가 장착되어 있지 않은 경우, 시스템을 작동하지 마십시오.
- Aviso** Plaquetas vazias e painéis de proteção têm três funções importantes: impedem a exposição a tensões e correntes elétricas perigosas dentro do chassi; apresentam interferência eletromagnética (EMI) que pode danificar outros equipamentos: direcionam o fluxo do ar refrigerado pelo chassi. Não opere o sistema a menos que todas as placas, plaquetas, tampas frontais e tampas traseiras estejam em seu devido lugar.
- Advarsel** Blanke frontplader og sidepaneler tjener tre vigtige formål: de forhindrer udsættelse for farlig spænding og strøm inde i chassiset, de isolerer elektromagnetisk interferens (EMI), der kan forstyrre andet udstyr, og de leder en strøm af kølig luft gennem chassiset. Betjen ikke systemet medmindre alle kort, frontplader, sidepaneler og bagpaneler er på plads.

تحذير	تؤدي كل من الواجهات الفارغة ولوحات التغطية ثلاث وظائف هامة: الحيلولة دون التعرض للجهد الكهربائي الخطير والتيارات الموجودة في الهيكل المعدني، حيث يحتوي كلاً منهما على واجهة كهرومغناطيسية ( ) والتي قد تعيق عمل الأجهزة الأخرى كما يقوم بتوجيه تيار التبريد داخل الهيكل المعدني. لا تحاول تشغيل النظام إلا إذا كانت كافة البطاقات والواجهات والأغطية الأمامية والخلفية موضوعة في مكانها.
Upozorenje	<b>Prazna prednja ploča i pokrovne ploče imaju tri važne funkcije: sprječavaju izlaganje opasnome visokom naponu i struji unutar kućišta, proizvode elektromagnetnu interferenciju koja može ometati rad ostalih uređaja, te usmjeravaju protok rashladnog zraka kroz kućište. Sustav nemojte koristiti ako sve kartice, te prednje, pokrovne i stražnje ploče nisu pravilno ugrađene.</b>
Upozornění	<b>Prázdné líčové desky a krycí panely mají tři důležité funkce: zabraňují odkrytí nebezpečného napětí a proudu uvnitř skříně; obsahují elektromagnetické rušení, které může rušit jiná zařízení; směřují proud chladícího vzduchu skříní. Nepoužívejte systém, pokud nejsou všechny karty, líčové desky, přední kryty a zadní kryty na svém místě.</b>
Προειδοποίηση	Οι κενές προσόψεις και τα κενά πλαίσια καλύμματος χρησιμεύουν για τρεις σημαντικές λειτουργίες: Αποκλείουν την έκθεση σε επικίνδυνες τάσεις και ρεύματα στο εσωτερικό του σασί, περικλείουν τις ηλεκτρομαγνητικές παρεμβολές (EMI) που ενδέχεται να προκαλέσουν προβλήματα σε άλλο εξοπλισμό και κατευθύνουν τη ροή του αέρα ψύξης μέσα στο σασί. Μην θέτετε το σύστημα σε λειτουργία αν δεν βρίσκονται στη θέση τους όλες οι κάρτες, οι μπροστινές πλάκες, οι προσόψεις και οι πλάτες.
אזהרה	לוחות כיסוי ריקים ולוחות כיסוי משמשים לשלוש פונקציות חשובות: הם מונעים חשיפה למתחים מסוכנים ולזרם בתוך התושבת; הם מכילים הפרעות אלקטרומגנטיות (EMI) העלולות לשבש ציוד אחר; והם מכוונים את זרימת האוויר המצנן דרך התושבת. אל תפעיל את המערכת אלא אם כל הכרטיסים, לוחות הכיסוי, הלוחות הקדמיים והכיסויים האחוריים נמצאים במקומם.
Opomena	Празните предни плочи и плочите за покривање служат за три важни функции: го спречуваат изложувањето на ризични напони и струи во куќиштето; содржат електромагнетни интерференции (EMI) што можат да попречуваат друга опрема; и го насочуваат протокот на воздухот за разладување низ куќиштето. Не работете со системот ако сите картички, предни плочи, предни капаци и задни капаци не се на своите места.
Ostrzeżenie	<b>Zaśleпки i panele osłonowe pełnią trzy ważne funkcje: zapobiegają kontaktowi użytkownika z niebezpiecznymi napięciami i prądami występującymi wewnątrz obudowy; pochłaniają zakłócenia elektromagnetyczne, które mogłyby negatywnie wpływać na działanie innych urządzeń; kierują przepływem powietrza chłodzącego wewnątrz obudowy. System można eksploatować wyłącznie wtedy, gdy zamontowane są wszystkie karty, zaślepki oraz przednie i tylne osłony.</b>
Upozornenie	<b>Prázdné líčové dosky a krycie panely majú tri dôležité funkcie: zabraňujú odkrytiu nebezpečného napätia a prúdu vnútri skrine; obsahujú elektromagnetické rušenie, ktoré môže rušiť iné zariadenia; smerujú prúd chladiaceho vzduchu cez skriňu. Nepoužívajte systém, pokiaľ nie sú všetky karty, líčové dosky, predné kryty a zadné kryty na svojom mieste.</b>

## Statement 1034—Backplane Voltage



**Warning**

**Hazardous voltage or energy is present on the backplane when the system is operating. Use caution when servicing.**

**Waarschuwing**

**Er is gevaarlijke spanning of energie aanwezig op de achterplaat wanneer het systeem bediend wordt. Wees voorzichtig bij het onderhoud.**

**Varoitus**

**Kun laite on toiminnassa, taustalevyyn muodostuu vaarallista jännitettä. Ole varovainen huoltaessasi laitetta.**

**Attention**

**Lorsque le système est en fonctionnement, des tensions électriques circulent sur le fond de panier. Prendre des précautions lors de la maintenance.**

**Warnung**

**Wenn das System in Betrieb ist, treten auf der Rückwandplatine gefährliche Spannungen oder Energien auf. Vorsicht bei der Wartung.**

**Avvertenza**

**Quando il sistema è in funzione, il pannello posteriore è sotto tensione pericolosa. Prestare attenzione quando si lavora sul sistema.**

**Advarsel**

**Farlig spenning er til stede på bakpanelet når systemet kjøres. Utvis forsiktighet under service.**

**Aviso**

**Há presença de voltagem perigosa ou de energia na placa traseira quando o sistema está em operação. Tenha cuidado ao fazer a manutenção.**

**¡Advertencia!**

**Cuando el sistema está en funcionamiento, el voltaje del plano trasero es peligroso. Tenga cuidado cuando lo revise.**

**Varning!**

**Farlig spänning föreligger på bakplattan när systemet körs. Var försiktig vid service.**

**Figyelem**

**A rendszer működése közben veszélyes feszültség vagy energia van jelen a hátlapon. Karbantartás közben óvatosan járjon el!**

**Предупреждение**

**При работе оборудования на разъемах задней панели присутствует высокое напряжение. Будьте внимательны при работе с оборудованием.**

**警告**

**当系统正在运行时，背板上有很危险的电压或能量。进行维修时务必小心。**

**警告**

**システムの稼働中は、バックプレーンに危険な電圧またはエネルギーがかかっています。保守作業を行うときは注意してください。**

**주의**

**시스템이 가동 중일 때 뒷면에서 위험한 전압 또는 에너지가 발생합니다. 서비스 수행시 주의하십시오.**

**Aviso**

**O sistema em funcionamento emite tensão ou energia elétrica perigosa no painel traseiro. Seja cauteloso ao fazer a manutenção.**



Advarsel	<b>Der er farlig spænding og energi på bagpladen når systemet er i brug. Vær forsigtig under servicering.</b>
تحذير	عند تشغيل النظام، يوجد قدر كبير من الجهد الكهربائي الخطير في الجزء الخلفي. كن حريصاً عند إجراء الصيانة.
Upozorenje	<b>Kad sustav radi, na stražnjoj je ploči prisutan opasan visoki napon ili energija. Budite oprezni kod servisiranja.</b>
Upozornění	<b>Při provozu systému je na zadní desce nebezpečné napětí nebo energie. Při opravě dbejte opatrnosti.</b>
Προειδοποίηση	Όταν το σύστημα λειτουργεί, στην πίσω πλάκα συνδέσεων είναι παρούσα επικίνδυνη τάση ή ενέργεια. Να είστε προσεκτικοί κατά τις εργασίες συντήρησης.
אזהרה	מתח מסוכן וחשמל קיימים בלוח האחורי כאשר המערכת פעילה. נקוט זהירות בעת הטיפול.
Opomena	На задната плоча има ризичен напон или енергија кога системот работи. Бидете претпазливи при сервисирањето.
Ostrzeżenie	<b>Podczas pracy systemu na płycie interfejsu magistrali występują niebezpieczne napięcia lub energia elektryczna. Przy wykonywaniu czynności serwisowych należy zachować ostrożność.</b>
Upozornenie	<b>Počas prevádzky systému je na zadnej doske nebezpečné napätie alebo energia. Pri oprave buďte opatrní.</b>

## Obtaining Documentation

Cisco documentation and additional literature are available on Cisco.com. This section explains the product documentation resources that Cisco offers.

### Cisco.com

You can access the most current Cisco documentation at this URL:

<http://www.cisco.com/techsupport>

You can access the Cisco website at this URL:

<http://www.cisco.com>

You can access international Cisco websites at this URL:

[http://www.cisco.com/public/countries\\_languages.shtml](http://www.cisco.com/public/countries_languages.shtml)

## Product Documentation DVD

The Product Documentation DVD is a library of technical product documentation on a portable medium. The DVD enables you to access installation, configuration, and command guides for Cisco hardware and software products. With the DVD, you have access to the HTML documentation and some of the PDF files found on the Cisco website at this URL:

<http://www.cisco.com/univercd/home/home.htm>

The Product Documentation DVD is created monthly and is released in the middle of the month. DVDs are available singly or by subscription. Registered Cisco.com users can order a Product Documentation DVD (product number DOC-DOCDVD= or DOC-DOCDVD=SUB) from Cisco Marketplace at the Product Documentation Store at this URL:

<http://www.cisco.com/go/marketplace/docstore>

## Ordering Documentation

You must be a registered Cisco.com user to access Cisco Marketplace. Registered users may order Cisco documentation at the Product Documentation Store at this URL:

<http://www.cisco.com/go/marketplace/docstore>

If you do not have a user ID or password, you can register at this URL:

<http://tools.cisco.com/RPF/register/register.do>

## Documentation Feedback

You can provide feedback about Cisco technical documentation on the Cisco Technical Support & Documentation site area by entering your comments in the feedback form available in every online document.

## Cisco Product Security Overview

Cisco provides a free online Security Vulnerability Policy portal at this URL:

[http://www.cisco.com/en/US/products/products\\_security\\_vulnerability\\_policy.html](http://www.cisco.com/en/US/products/products_security_vulnerability_policy.html)

From this site, you will find information about how to do the following:

- Report security vulnerabilities in Cisco products
- Obtain assistance with security incidents that involve Cisco products
- Register to receive security information from Cisco

A current list of security advisories, security notices, and security responses for Cisco products is available at this URL:

<http://www.cisco.com/go/psirt>

To see security advisories, security notices, and security responses as they are updated in real time, you can subscribe to the Product Security Incident Response Team Really Simple Syndication (PSIRT RSS) feed. Information about how to subscribe to the PSIRT RSS feed is found at this URL:

[http://www.cisco.com/en/US/products/products\\_psirt\\_rss\\_feed.html](http://www.cisco.com/en/US/products/products_psirt_rss_feed.html)

## Reporting Security Problems in Cisco Products

Cisco is committed to delivering secure products. We test our products internally before we release them, and we strive to correct all vulnerabilities quickly. If you think that you have identified a vulnerability in a Cisco product, contact PSIRT:

- For emergencies only—[security-alert@cisco.com](mailto:security-alert@cisco.com)

An emergency is either a condition in which a system is under active attack or a condition for which a severe and urgent security vulnerability should be reported. All other conditions are considered nonemergencies.

- For nonemergencies—[psirt@cisco.com](mailto:psirt@cisco.com)

In an emergency, you can also reach PSIRT by telephone:

- 1 877 228-7302
- 1 408 525-6532



**Tip**

We encourage you to use Pretty Good Privacy (PGP) or a compatible product (for example, GnuPG) to encrypt any sensitive information that you send to Cisco. PSIRT can work with information that has been encrypted with PGP versions 2.x through 9.x.

Never use a revoked encryption key or an expired encryption key. The correct public key to use in your correspondence with PSIRT is the one linked in the Contact Summary section of the Security Vulnerability Policy page at this URL:

[http://www.cisco.com/en/US/products/products\\_security\\_vulnerability\\_policy.html](http://www.cisco.com/en/US/products/products_security_vulnerability_policy.html)

The link on this page has the current PGP key ID in use.

If you do not have or use PGP, contact PSIRT to find other means of encrypting the data before sending any sensitive material.

## Product Alerts and Field Notices

Modifications to or updates about Cisco products are announced in Cisco Product Alerts and Cisco Field Notices. You can receive Cisco Product Alerts and Cisco Field Notices by using the Product Alert Tool on Cisco.com. This tool enables you to create a profile and choose those products for which you want to receive information.

To access the Product Alert Tool, you must be a registered Cisco.com user. (To register as a Cisco.com user, go to this URL: <http://tools.cisco.com/RPF/register/register.do>) Registered users can access the tool at this URL: <http://tools.cisco.com/Support/PAT/do/ViewMyProfiles.do?local=en>

# Obtaining Technical Assistance

Cisco Technical Support provides 24-hour-a-day award-winning technical assistance. The Cisco Technical Support & Documentation website on Cisco.com features extensive online support resources. In addition, if you have a valid Cisco service contract, Cisco Technical Assistance Center (TAC) engineers provide telephone support. If you do not have a valid Cisco service contract, contact your reseller.

## Cisco Technical Support & Documentation Website

The Cisco Technical Support & Documentation website provides online documents and tools for troubleshooting and resolving technical issues with Cisco products and technologies. The website is available 24 hours a day at this URL:

<http://www.cisco.com/techsupport>

Access to all tools on the Cisco Technical Support & Documentation website requires a Cisco.com user ID and password. If you have a valid service contract but do not have a user ID or password, you can register at this URL:

<http://tools.cisco.com/RPF/register/register.do>



**Note**

Use the **Cisco Product Identification Tool** to locate your product serial number before submitting a request for service online or by phone. You can access this tool from the Cisco Technical Support & Documentation website by clicking the **Tools & Resources** link, clicking the **All Tools (A-Z)** tab, and then choosing **Cisco Product Identification Tool** from the alphabetical list. This tool offers three search options: by product ID or model name; by tree view; or, for certain products, by copying and pasting **show** command output. Search results show an illustration of your product with the serial number label location highlighted. Locate the serial number label on your product and record the information before placing a service call.



**Tip**

Displaying and Searching on Cisco.com

If you suspect that the browser is not refreshing a web page, force the browser to update the web page by holding down the Ctrl key while pressing F5.

To find technical information, narrow your search to look in technical documentation, not the entire Cisco.com website. On the Cisco.com home page, click the **Advanced Search** link under the Search box and then click the **Technical Support & Documentation**.radio button.

To provide feedback about the Cisco.com website or a particular technical document, click **Contacts & Feedback** at the top of any Cisco.com web page.

## Submitting a Service Request

Using the online TAC Service Request Tool is the fastest way to open S3 and S4 service requests. (S3 and S4 service requests are those in which your network is minimally impaired or for which you require product information.) After you describe your situation, the TAC Service Request Tool provides recommended solutions. If your issue is not resolved using the recommended resources, your service request is assigned to a Cisco engineer. The TAC Service Request Tool is located at this URL:

<http://www.cisco.com/techsupport/servicerequest>

For S1 or S2 service requests, or if you do not have Internet access, contact the Cisco TAC by telephone. (S1 or S2 service requests are those in which your production network is down or severely degraded.) Cisco engineers are assigned immediately to S1 and S2 service requests to help keep your business operations running smoothly.

To open a service request by telephone, use one of the following numbers:

Asia-Pacific: +61 2 8446 7411

Australia: 1 800 805 227

EMEA: +32 2 704 55 55

USA: 1 800 553 2447

For a complete list of Cisco TAC contacts, go to this URL:

<http://www.cisco.com/techsupport/contacts>

## Definitions of Service Request Severity

To ensure that all service requests are reported in a standard format, Cisco has established severity definitions.

**Severity 1 (S1)**—An existing network is “down” or there is a critical impact to your business operations. You and Cisco will commit all necessary resources around the clock to resolve the situation.

**Severity 2 (S2)**—Operation of an existing network is severely degraded, or significant aspects of your business operations are negatively affected by inadequate performance of Cisco products. You and Cisco will commit full-time resources during normal business hours to resolve the situation.

**Severity 3 (S3)**—Operational performance of the network is impaired while most business operations remain functional. You and Cisco will commit resources during normal business hours to restore service to satisfactory levels.

**Severity 4 (S4)**—You require information or assistance with Cisco product capabilities, installation, or configuration. There is little or no effect on your business operations.

# Obtaining Additional Publications and Information

Information about Cisco products, technologies, and network solutions is available from various online and printed sources.

- The *Cisco Product Quick Reference Guide* is a handy, compact reference tool that includes brief product overviews, key features, sample part numbers, and abbreviated technical specifications for many Cisco products that are sold through channel partners. It is updated twice a year and includes the latest Cisco channel product offerings. To order and find out more about the *Cisco Product Quick Reference Guide*, go to this URL:

<http://www.cisco.com/go/guide>

- Cisco Marketplace provides a variety of Cisco books, reference guides, documentation, and logo merchandise. Visit Cisco Marketplace, the company store, at this URL:
- Cisco Press publishes a wide range of general networking, training, and certification titles. Both new and experienced users will benefit from these publications. For current Cisco Press titles and other information, go to Cisco Press at this URL:

<http://www.ciscopress.com>

- *Packet* magazine is the magazine for Cisco networking professionals. Each quarter, *Packet* delivers coverage of the latest industry trends, technology breakthroughs, and Cisco products and solutions, as well as network deployment and troubleshooting tips, configuration examples, customer case studies, certification and training information, and links to scores of in-depth online resources. You can subscribe to *Packet* magazine at this URL:

<http://www.cisco.com/packet>

- *Internet Protocol Journal* is a quarterly journal published by Cisco Systems for engineering professionals involved in designing, developing, and operating public and private internets and intranets. You can access the *Internet Protocol Journal* at this URL:

<http://www.cisco.com/ipj>

- Networking products offered by Cisco Systems, as well as customer support services, can be obtained at this URL:

<http://www.cisco.com/en/US/products/index.html>

- Networking Professionals Connection is an interactive website where networking professionals share questions, suggestions, and information about networking products and technologies with Cisco experts and other networking professionals. Join a discussion at this URL:

<http://www.cisco.com/discuss/networking>

- “What’s New in Cisco Documentation” is an online publication that provides information about the latest documentation releases for Cisco products. Updated monthly, this online publication is organized by product category to direct you quickly to the documentation for your products. You can view the latest release of “What’s New in Cisco Documentation” at this URL:

<http://www.cisco.com/univercd/cc/td/doc/abtunicd/136957.htm>

- World-class networking training is available from Cisco. You can view current offerings at this URL:

<http://www.cisco.com/en/US/learning/index.html>

---

This document is to be used in conjunction with the Cisco IOS Software Configuration Guide.

CCVP, the Cisco Logo, and the Cisco Square Bridge logo are trademarks of Cisco Systems, Inc.; Changing the Way We Work, Live, Play, and Learn is a service mark of Cisco Systems, Inc.; and Access Registrar, Aironet, BPX, Catalyst, CCDA, CCDP, CCIE, CCIP, CCNA, CCNP, CCSP, Cisco, the Cisco Certified Internetwork Expert logo, Cisco IOS, Cisco Press, Cisco Systems, Cisco Systems Capital, the Cisco Systems logo, Cisco Unity, Enterprise/Solver, EtherChannel, EtherFast, EtherSwitch, Fast Step, Follow Me Browsing, FormShare, GigaDrive, GigaStack, HomeLink, Internet Quotient, IOS, IP/TV, iQ Expertise, the iQ logo, iQ Net Readiness Scorecard, iQuick Study, LightStream, Linksys, MeetingPlace, MGX, Networking Academy, Network Registrar, *Packet*, PIX, ProConnect, RateMUX, ScriptShare, SlideCast, SMARTnet, StackWise, The Fastest Way to Increase Your Internet Quotient, and TransPath are registered trademarks of Cisco Systems, Inc. and/or its affiliates in the United States and certain other countries.

All other trademarks mentioned in this document or Website are the property of their respective owners. The use of the word partner does not imply a partnership relationship between Cisco and any other company. (0609R)

© 2005–2006 Cisco Systems, Inc. All rights reserved.



## Free Manuals Download Website

<http://myh66.com>

<http://usermanuals.us>

<http://www.somanuals.com>

<http://www.4manuals.cc>

<http://www.manual-lib.com>

<http://www.404manual.com>

<http://www.luxmanual.com>

<http://aubethermostatmanual.com>

Golf course search by state

<http://golfingnear.com>

Email search by domain

<http://emailbydomain.com>

Auto manuals search

<http://auto.somanuals.com>

TV manuals search

<http://tv.somanuals.com>