



Installation and Upgrade Guide for Cisco Unified Videoconferencing 3515 MCU12 and MCU24 Release 5.1

Corporate Headquarters

Cisco Systems, Inc.
170 West Tasman Drive
San Jose, CA 95134-1706
USA
<http://www.cisco.com>
Tel: 408 526-4000
800 553-NETS (6387)
Fax: 408 526-4100

Text Part Number: OL-11897-01



THE SPECIFICATIONS AND INFORMATION REGARDING THE PRODUCTS IN THIS MANUAL ARE SUBJECT TO CHANGE WITHOUT NOTICE. ALL STATEMENTS, INFORMATION, AND RECOMMENDATIONS IN THIS MANUAL ARE BELIEVED TO BE ACCURATE BUT ARE PRESENTED WITHOUT WARRANTY OF ANY KIND, EXPRESS OR IMPLIED. USERS MUST TAKE FULL RESPONSIBILITY FOR THEIR APPLICATION OF ANY PRODUCTS.

THE SOFTWARE LICENSE AND LIMITED WARRANTY FOR THE ACCOMPANYING PRODUCT ARE SET FORTH IN THE INFORMATION PACKET THAT SHIPPED WITH THE PRODUCT AND ARE INCORPORATED HEREIN BY THIS REFERENCE. IF YOU ARE UNABLE TO LOCATE THE SOFTWARE LICENSE OR LIMITED WARRANTY, CONTACT YOUR CISCO REPRESENTATIVE FOR A COPY.

The Cisco implementation of TCP header compression is an adaptation of a program developed by the University of California, Berkeley (UCB) as part of UCB's public domain version of the UNIX operating system. All rights reserved. Copyright © 1981, Regents of the University of California.

NOTWITHSTANDING ANY OTHER WARRANTY HEREIN, ALL DOCUMENT FILES AND SOFTWARE OF THESE SUPPLIERS ARE PROVIDED "AS IS" WITH ALL FAULTS. CISCO AND THE ABOVE-NAMED SUPPLIERS DISCLAIM ALL WARRANTIES, EXPRESSED OR IMPLIED, INCLUDING, WITHOUT LIMITATION, THOSE OF MERCHANTABILITY, FITNESS FOR A PARTICULAR PURPOSE AND NONINFRINGEMENT OR ARISING FROM A COURSE OF DEALING, USAGE, OR TRADE PRACTICE.

IN NO EVENT SHALL CISCO OR ITS SUPPLIERS BE LIABLE FOR ANY INDIRECT, SPECIAL, CONSEQUENTIAL, OR INCIDENTAL DAMAGES, INCLUDING, WITHOUT LIMITATION, LOST PROFITS OR LOSS OR DAMAGE TO DATA ARISING OUT OF THE USE OR INABILITY TO USE THIS MANUAL, EVEN IF CISCO OR ITS SUPPLIERS HAVE BEEN ADVISED OF THE POSSIBILITY OF SUCH DAMAGES.

CCVP, the Cisco Logo, and the Cisco Square Bridge logo are trademarks of Cisco Systems, Inc.; Changing the Way We Work, Live, Play, and Learn is a service mark of Cisco Systems, Inc.; and Access Registrar, Aironet, BPX, Catalyst, CCDA, CCDP, CCIE, CCIP, CCNA, CCNP, CCSP, Cisco, the Cisco Certified Internetwork Expert logo, Cisco IOS, Cisco Press, Cisco Systems, Cisco Systems Capital, the Cisco Systems logo, Cisco Unity, Enterprise/Solver, EtherChannel, EtherFast, EtherSwitch, Fast Step, Follow Me Browsing, FormShare, GigaDrive, GigaStack, HomeLink, Internet Quotient, IOS, IP/TV, iQ Expertise, the iQ logo, iQ Net Readiness Scorecard, iQuick Study, LightStream, Linksys, MeetingPlace, MGX, Networking Academy, Network Registrar, *Packet*, PIX, ProConnect, RateMUX, ScriptShare, SlideCast, SMARTnet, StackWise, The Fastest Way to Increase Your Internet Quotient, and TransPath are registered trademarks of Cisco Systems, Inc. and/or its affiliates in the United States and certain other countries.

All other trademarks mentioned in this document or Website are the property of their respective owners. The use of the word partner does not imply a partnership relationship between Cisco and any other company. (0609R)

Installation and Upgrade Guide for Cisco Unified Videoconferencing 3515 MCU12 and MCU24 Release 5.1
© 2007 Cisco Systems, Inc. All rights reserved.



Preface vii

Purpose	vii
Audience	vii
Organization	vii
Document Conventions	viii
Obtaining Documentation	viii
Cisco.com	viii
Product Documentation DVD	ix
Ordering Documentation	ix
Documentation Feedback	ix
Cisco Product Security Overview	ix
Reporting Security Problems in Cisco Products	x
Product Alerts and Field Notices	x
Obtaining Technical Assistance	xi
Cisco Technical Support & Documentation Website	xi
Submitting a Service Request	xii
Definitions of Service Request Severity	xii
Obtaining Additional Publications and Information	xii

CHAPTER 1

Cisco Unified Videoconferencing 3515 MCU Functionality	1-1
Introducing the Cisco Unified Videoconferencing 3515 MCU	1-1
About Cisco Unified Videoconferencing 3515 MCU Users	1-2
Administrators	1-2
Chair Controllers and Operators	1-2
Conference users	1-2
Main Features of the 3515 MCU	1-2
Port Capacities of the 3515 MCU12 and MCU24	1-5
Cisco Unified Videoconferencing 3515 MCU12 Port Capacity	1-5
Cisco Unified Videoconferencing 3515 MCU24 Port Capacity	1-5
About Cisco Unified Videoconferencing 3515 MCU Architecture	1-6
About Cisco Unified Videoconferencing 3515 MCU Topologies	1-7
Centralized Topology	1-7
Cascaded Conferences	1-7

CHAPTER 2

Setting Up Your Cisco Unified Videoconferencing 3515 MCU 2-1

- Physical Description of the Cisco Unified Videoconferencing 3515 MCU 2-1
- Preparing to Install the 3515 MCU 2-2
- Verifying the Package Contents of the 3515 MCU 2-3
- Mounting the Cisco Unified Videoconferencing 3515 MCU Unit in a 19-inch Rack 2-4
- Cisco Unified Videoconferencing 3515 MCU Unit Initial Configuration 2-5
 - Connecting to a PC 2-5
 - Setting the IP Address 2-6
 - Connecting the Cisco Unified Videoconferencing 3515 MCU Unit to the LAN 2-8
- Video Processing Module Initial Configuration for the 3515 MCU 2-8
 - Accessing the Video Processing Module Main Menu 2-8
 - Setting the IP Address 2-9
 - Setting Ethernet Speed and Duplex Parameters 2-9
 - Changing the Configuration Software Password 2-10
 - Changing the Security Level 2-11
 - Pointing the EMP to the Controlling Cisco Unified Videoconferencing 3515 MCU 2-11
 - Changing Advanced Configuration Settings 2-12
 - Saving Network Configuration Settings 2-13
- Managing and Monitoring the Cisco Unified Videoconferencing 3515 MCU Unit 2-13
 - SNMP Management 2-13
 - Local Port Monitoring Connections 2-13
 - Performing Software Upgrades 2-14
- Accessing the Cisco Unified Videoconferencing 3515 MCU Administrator Interface 2-14
- Registering the Online Help for the 3515 MCU 2-15
 - Netscape Navigator Users 2-15

CHAPTER 3

Using the Cisco Software Upgrade Utility 3-1

- Introduction 3-1
- Launching the Cisco Software Upgrade Utility 3-1
- Upgrading Software 3-2

CHAPTER 4

Cisco Unified Videoconferencing 3515 MCU Cable Connections and Pin-outs 4-1

- Unit RS-232 9-Pin Serial Port on the 3515 MCU 4-1
- RJ-45 8-Pin IP Network Port on the 3515 MCU 4-2

CHAPTER 5

Cisco Unified Videoconferencing 3515 MCU Technical Specifications 5-1

- Technical Specifications Table for the 3515 MCU 5-1

CHAPTER 6**Cisco Unified Videoconferencing 3515 MCU Safety 6-1**

Electrical Safety for the 3515 MCU 6-1

Grounding 6-1

High Voltage 6-2

ESD Procedures for the 3515 MCU 6-2

CHAPTER 7**Cisco Unified Videoconferencing 3515 MCU Compliance and Certifications 7-1**

Safety Compliance for the 3515 MCU 7-1

EMC for the 3515 MCU 7-1

FCC Part 15 Notice 7-2

Telecom for the 3515 MCU 7-2

ACTA Part 68 Notice 7-2

Industry Canada 7-3

Environmental Compliance for the 3515 MCU 7-4

INDEX



Preface

Revised: November 27, 2006, OL-11897-01

Purpose

This guide describes how to install and upgrade the Cisco Unified Videoconferencing 3515 MCU12 and the Cisco Unified Videoconferencing 3515 MCU24 unit.

Audience

This guide is intended for network administrators who need instructions about how to install and upgrade the Cisco Unified Videoconferencing 3515 MCU unit.

Organization

This manual is organized as follows:

Chapter	Description
Chapter 1, “Cisco Unified Videoconferencing 3515 MCU Functionality”	Provides a general overview of Cisco Unified Videoconferencing 3515 MCU products, features, and network architecture.
Chapter 2, “Setting Up Your Cisco Unified Videoconferencing 3515 MCU”	Describes how to install the Cisco Unified Videoconferencing 3515 MCU, how to use the Administrator interface to configure board settings and add Cisco Unified Videoconferencing 3515 MCU users.
Chapter 3, “Using the Cisco Software Upgrade Utility”	Describes how to use the Cisco Software Upgrade Utility
Chapter 4, “Cisco Unified Videoconferencing 3515 MCU Cable Connections and Pin-outs”	Describes the pin-to-pin and pin-out configurations of the connectors and cables of the Cisco Unified Videoconferencing 3515 MCU

Chapter	Description
Chapter 5, “Cisco Unified Videoconferencing 3515 MCU Technical Specifications”	Describes the technical specifications for the Cisco Unified Videoconferencing 3515 MCU.
Chapter 6, “Cisco Unified Videoconferencing 3515 MCU Safety”	Describes safety procedures and requirements for operating the Cisco Unified Videoconferencing 3515 MCU.
Chapter 7, “Cisco Unified Videoconferencing 3515 MCU Compliance and Certifications”	Provides certifications that have been approved for the Cisco Unified Videoconferencing 3515 MCU.

Document Conventions

This document uses the following conventions:

Convention	Description
boldface font	Commands and keywords are in boldface .
<i>italic font</i>	Arguments for which you supply values are in <i>italics</i> .
[]	Elements in square brackets are optional.
{ x y z }	Alternative keywords are grouped in braces and separated by vertical bars.
[x y z]	Optional alternative keywords are grouped in brackets and separated by vertical bars.
string	A nonquoted set of characters. Do not use quotation marks around the string or the string will include the quotation marks.
screen font	Terminal sessions and information the system displays are in <code>screen font</code> .
boldface screen font	Information you must enter is in boldface screen font .
<i>italic screen font</i>	Arguments for which you supply values are in <i>italic screen font</i> .
^	The symbol ^ represents the key labeled Control—for example, the key combination ^D in a screen display means hold down the Control key while you press the D key.
< >	Nonprinting characters, such as passwords are in angle brackets.

Obtaining Documentation

Cisco documentation and additional literature are available on Cisco.com. This section explains the product documentation resources that Cisco offers.

Cisco.com

You can access the most current Cisco documentation at this URL:

<http://www.cisco.com/techsupport>

You can access the Cisco website at this URL:

<http://www.cisco.com>

You can access international Cisco websites at this URL:

http://www.cisco.com/public/countries_languages.shtml

Product Documentation DVD

The Product Documentation DVD is a library of technical product documentation on a portable medium. The DVD enables you to access installation, configuration, and command guides for Cisco hardware and software products. With the DVD, you have access to the HTML documentation and some of the PDF files found on the Cisco website at this URL:

<http://www.cisco.com/univercd/home/home.htm>

The Product Documentation DVD is created and released regularly. DVDs are available singly or by subscription. Registered Cisco.com users can order a Product Documentation DVD (product number DOC-DOCDVD= or DOC-DOCDVD=SUB) from Cisco Marketplace at the Product Documentation Store at this URL:

<http://www.cisco.com/go/marketplace/docstore>

Ordering Documentation

You must be a registered Cisco.com user to access Cisco Marketplace. Registered users may order Cisco documentation at the Product Documentation Store at this URL:

<http://www.cisco.com/go/marketplace/docstore>

If you do not have a user ID or password, you can register at this URL:

<http://tools.cisco.com/RPF/register/register.do>

Documentation Feedback

You can provide feedback about Cisco technical documentation on the Cisco Technical Support & Documentation site area by entering your comments in the feedback form available in every online document.

Cisco Product Security Overview

Cisco provides a free online Security Vulnerability Policy portal at this URL:

http://www.cisco.com/en/US/products/products_security_vulnerability_policy.html

From this site, you will find information about how to do the following:

- Report security vulnerabilities in Cisco products
- Obtain assistance with security incidents that involve Cisco products
- Register to receive security information from Cisco

A current list of security advisories, security notices, and security responses for Cisco products is available at this URL:

<http://www.cisco.com/go/psirt>

To see security advisories, security notices, and security responses as they are updated in real time, you can subscribe to the Product Security Incident Response Team Really Simple Syndication (PSIRT RSS) feed. Information about how to subscribe to the PSIRT RSS feed is found at this URL:

http://www.cisco.com/en/US/products/products_psirt_rss_feed.html

Reporting Security Problems in Cisco Products

Cisco is committed to delivering secure products. We test our products internally before we release them, and we strive to correct all vulnerabilities quickly. If you think that you have identified a vulnerability in a Cisco product, contact PSIRT:

- For emergencies only—security-alert@cisco.com

An emergency is either a condition in which a system is under active attack or a condition for which a severe and urgent security vulnerability should be reported. All other conditions are considered nonemergencies.

- For nonemergencies—psirt@cisco.com

In an emergency, you can also reach PSIRT by telephone:

- 1 877 228-7302
- 1 408 525-6532



Tip

We encourage you to use Pretty Good Privacy (PGP) or a compatible product (for example, GnuPG) to encrypt any sensitive information that you send to Cisco. PSIRT can work with information that has been encrypted with PGP versions 2.x through 9.x.

Never use a revoked encryption key or an expired encryption key. The correct public key to use in your correspondence with PSIRT is the one linked in the Contact Summary section of the Security Vulnerability Policy page at this URL:

http://www.cisco.com/en/US/products/products_security_vulnerability_policy.html

The link on this page has the current PGP key ID in use.

If you do not have or use PGP, contact PSIRT to find other means of encrypting the data before sending any sensitive material.

Product Alerts and Field Notices

Modifications to or updates about Cisco products are announced in Cisco Product Alerts and Cisco Field Notices. You can receive Cisco Product Alerts and Cisco Field Notices by using the Product Alert Tool on Cisco.com. This tool enables you to create a profile and choose those products for which you want to receive information.

To access the Product Alert Tool, you must be a registered Cisco.com user. (To register as a Cisco.com user, go to this URL: <http://tools.cisco.com/RPF/register/register.do>) Registered users can access the tool at this URL: <http://tools.cisco.com/Support/PAT/do/ViewMyProfiles.do?local=en>

Obtaining Technical Assistance

Cisco Technical Support provides 24-hour-a-day award-winning technical assistance. The Cisco Technical Support & Documentation website on Cisco.com features extensive online support resources. In addition, if you have a valid Cisco service contract, Cisco Technical Assistance Center (TAC) engineers provide telephone support. If you do not have a valid Cisco service contract, contact your reseller.

Cisco Technical Support & Documentation Website

The Cisco Technical Support & Documentation website provides online documents and tools for troubleshooting and resolving technical issues with Cisco products and technologies. The website is available 24 hours a day at this URL:

<http://www.cisco.com/techsupport>

Access to all tools on the Cisco Technical Support & Documentation website requires a Cisco.com user ID and password. If you have a valid service contract but do not have a user ID or password, you can register at this URL:

<http://tools.cisco.com/RPF/register/register.do>



Note

Use the **Cisco Product Identification Tool** to locate your product serial number before submitting a request for service online or by phone. You can access this tool from the Cisco Technical Support & Documentation website by clicking the **Tools & Resources** link, clicking the **All Tools (A-Z)** tab, and then choosing **Cisco Product Identification Tool** from the alphabetical list. This tool offers three search options: by product ID or model name; by tree view; or, for certain products, by copying and pasting **show** command output. Search results show an illustration of your product with the serial number label location highlighted. Locate the serial number label on your product and record the information before placing a service call.



Tip

Displaying and Searching on Cisco.com

If you suspect that the browser is not refreshing a web page, force the browser to update the web page by holding down the Ctrl key while pressing F5.

To find technical information, narrow your search to look in technical documentation, not the entire Cisco.com website. On the Cisco.com home page, click the **Advanced Search** link under the Search box and then click the **Technical Support & Documentation** radio button.

To provide feedback about the Cisco.com website or a particular technical document, click **Contacts & Feedback** at the top of any Cisco.com web page.

Submitting a Service Request

Using the online TAC Service Request Tool is the fastest way to open S3 and S4 service requests. (S3 and S4 service requests are those in which your network is minimally impaired or for which you require product information.) After you describe your situation, the TAC Service Request Tool provides recommended solutions. If your issue is not resolved using the recommended resources, your service request is assigned to a Cisco engineer. The TAC Service Request Tool is located at this URL:

<http://www.cisco.com/techsupport/servicerequest>

For S1 or S2 service requests, or if you do not have Internet access, contact the Cisco TAC by telephone. (S1 or S2 service requests are those in which your production network is down or severely degraded.) Cisco engineers are assigned immediately to S1 and S2 service requests to help keep your business operations running smoothly.

To open a service request by telephone, use one of the following numbers:

Asia-Pacific: +61 2 8446 7411

Australia: 1 800 805 227

EMEA: +32 2 704 55 55

USA: 1 800 553 2447

For a complete list of Cisco TAC contacts, go to this URL:

<http://www.cisco.com/techsupport/contacts>

Definitions of Service Request Severity

To ensure that all service requests are reported in a standard format, Cisco has established severity definitions.

Severity 1 (S1)—An existing network is “down” or there is a critical impact to your business operations. You and Cisco will commit all necessary resources around the clock to resolve the situation.

Severity 2 (S2)—Operation of an existing network is severely degraded, or significant aspects of your business operations are negatively affected by inadequate performance of Cisco products. You and Cisco will commit full-time resources during normal business hours to resolve the situation.

Severity 3 (S3)—Operational performance of the network is impaired while most business operations remain functional. You and Cisco will commit resources during normal business hours to restore service to satisfactory levels.

Severity 4 (S4)—You require information or assistance with Cisco product capabilities, installation, or configuration. There is little or no effect on your business operations.

Obtaining Additional Publications and Information

Information about Cisco products, technologies, and network solutions is available from various online and printed sources.

- The Cisco Online Subscription Center is the website where you can sign up for a variety of Cisco e-mail newsletters and other communications. Create a profile and then select the subscriptions that you would like to receive. To visit the Cisco Online Subscription Center, go to this URL:

<http://www.cisco.com/offer/subscribe>

- The *Cisco Product Quick Reference Guide* is a handy, compact reference tool that includes brief product overviews, key features, sample part numbers, and abbreviated technical specifications for many Cisco products that are sold through channel partners. It is updated twice a year and includes the latest Cisco channel product offerings. To order and find out more about the *Cisco Product Quick Reference Guide*, go to this URL:
<http://www.cisco.com/go/guide>
- Cisco Marketplace provides a variety of Cisco books, reference guides, documentation, and logo merchandise. Visit Cisco Marketplace, the company store, at this URL:
<http://www.cisco.com/go/marketplace/>
- Cisco Press publishes a wide range of general networking, training, and certification titles. Both new and experienced users will benefit from these publications. For current Cisco Press titles and other information, go to Cisco Press at this URL:
<http://www.ciscopress.com>
- *Internet Protocol Journal* is a quarterly journal published by Cisco Systems for engineering professionals involved in designing, developing, and operating public and private internets and intranets. You can access the *Internet Protocol Journal* at this URL:
<http://www.cisco.com/ipj>
- Networking products offered by Cisco Systems, as well as customer support services, can be obtained at this URL:
<http://www.cisco.com/en/US/products/index.html>
- Networking Professionals Connection is an interactive website where networking professionals share questions, suggestions, and information about networking products and technologies with Cisco experts and other networking professionals. Join a discussion at this URL:
<http://www.cisco.com/discuss/networking>
- “What’s New in Cisco Documentation” is an online publication that provides information about the latest documentation releases for Cisco products. Updated monthly, this online publication is organized by product category to direct you quickly to the documentation for your products. You can view the latest release of “What’s New in Cisco Documentation” at this URL:
<http://www.cisco.com/univercd/cc/td/doc/abtnicd/136957.htm>
- World-class networking training is available from Cisco. You can view current offerings at this URL:
<http://www.cisco.com/en/US/learning/index.html>



Cisco Unified Videoconferencing 3515 MCU Functionality

This section describes the following topics:

- [Introducing the Cisco Unified Videoconferencing 3515 MCU, page 1-1](#)
- [About Cisco Unified Videoconferencing 3515 MCU Users, page 1-2](#)
- [Main Features of the 3515 MCU, page 1-2](#)
- [Port Capacities of the 3515 MCU12 and MCU24, page 1-5](#)
- [About Cisco Unified Videoconferencing 3515 MCU Architecture, page 1-6](#)
- [About Cisco Unified Videoconferencing 3515 MCU Topologies, page 1-7](#)

Introducing the Cisco Unified Videoconferencing 3515 MCU

The Cisco Unified Videoconferencing 3515 MCU enables multimedia, multiparty collaboration in applications such as group conferencing, distance learning, training and video telephony. The Cisco Unified Videoconferencing 3515 MCU supports multimedia, multiparty communications in the board room, at the desktop, in the home, or on the road over wireless.

The Cisco Unified Videoconferencing 3515 MCU provides core IP-centric functionality, a wide range of layouts, powerful audio and video transcoding, an open API for customer application development, support of web-initiated data collaboration, and software upgradeable technology. Services are pre-configured so that they suit most conferencing requirements. However, when necessary, administrators can create customized services to suit their networks and user needs.

About Cisco Unified Videoconferencing 3515 MCU Users

The Cisco Unified Videoconferencing 3515 MCU provides an intuitive web interface with a single point of entry for configuring, controlling and monitoring the Cisco Unified Videoconferencing 3515 MCU unit and conference sessions. Access to the interfaces is password-protected for four types of users—Administrators, Chair Controllers, Operators and conference users.

Administrators

Administrators use the Administrator interface for configuring, controlling and managing the Cisco Unified Videoconferencing 3515 MCU, conference services and supporting devices and applications.

Chair Controllers and Operators

Chair Controllers and Operators can use the Conference Control interface for controlling audio, video and data connections, for selecting advanced conference view image positioning and multiple layouts, and for creating new conferences and sub-conferences.

Chair Controllers can use the Conference Control interface to view conference details and manage a specific conference.

Operators have a global view of all current conferences, and can act as Chair Controllers for all current conferences.

Conference users

Conference users participate in actual video or audio conferences.

Main Features of the 3515 MCU

[Table 1-1](#) lists the main features provided by the Cisco Unified Videoconferencing 3515 MCU for effective audio and videoconferencing and a satisfying user experience.

Table 1-1 Summary of Cisco Unified Videoconferencing 3515 MCU Features

Feature	Description
Flat capacity	Each conference participant can connect with his or her own optimal codec, resolution and bandwidth (from 64 Kbps up to 2 Mbps) without affecting other participants or the MCU capacity.
Superior video quality	Video and audio processing is carried out per user rather than per conference. Each user connects using unique, optimized audio and video settings to enjoy the best audio and video quality supported by his/her endpoint and network.

Table 1-1 Summary of Cisco Unified Videoconferencing 3515 MCU Features (continued)

Feature	Description
Seamless interoperability	<p>The Cisco Unified Videoconferencing 3515 MCU is built on the strong foundation of the Cisco H.323 and SIP software, ensuring full compliance and unmatched interoperability with IP and ISDN networks.</p> <p>The MCU enables H.323, SIP and SCCP devices to participate in the same conference session.</p> <p>When used with the Cisco Unified Videoconferencing 3500 Gateway, the MCU also enables ISDN and V.35 wireless devices to participate in the same conference session.</p>
Intuitive web-based management and control	Both the Cisco Unified Videoconferencing 3515 MCU system and actual conference sessions are managed, configured, and dynamically modified through an intuitive, web-based interface that offers easy, high-level conference control and administrative flexibility for an enhanced user experience.
Supported protocols	<ul style="list-style-type: none"> • H.323 version 4 • SIP RFC 3261 for the Session Initiation Protocol • SCCP • H.243 for conference control • RFC 2833 for in-band DTMF with SIP • H.281 for far end camera control (FECC) • H.235 for IP-based media encryption • H.239 for standard simultaneous transmission of live video and presentation sharing feeds. • SDP (RFC 3264, 2327) • T.120 • H.320 (when using a gateway) <p>Note The Cisco Unified Videoconferencing 3515 MCU supports calls from H.323 and SIP endpoints in the same conference. Call signalling is handled on all ports regardless of the protocol type.</p>
Audio transcoding codecs	<ul style="list-style-type: none"> • G.711 A/μ Law • G.722 • G.722.1 • G.723.1 • G.728 • G.729 A and B

Table 1-1 Summary of Cisco Unified Videoconferencing 3515 MCU Features (continued)

Feature	Description
Unmatched video quality	<p>The Cisco Unified Videoconferencing 3515 MCU delivers exceptionally high quality video and audio processing, using latest industry standards and leveraging upon advanced software upgradeable DSP chips. The Cisco QualiVision feature provides highly improved, standard-based video quality for networks with packet loss, assuring best video quality at all times.</p> <p>The Cisco Unified Videoconferencing 3515 MCU achieves the best video quality by supporting the following video capabilities:</p> <ul style="list-style-type: none"> • H.261, H.263 and H.264 in the same conference • A choice of 26 Continuous Presence layouts • Up to 2 Mbps on each stream without affecting capacity • QCIF, CIF and 4CIF in the same conference without affecting capacity • VGA, SVGA, XGA (supported for presentation channel only)
Multi-view (Dual Video)	Supports dual-screen video and data transmissions to endpoints supporting two monitors using the H.239 standard or TANDBERG DuoVideo. One monitor receives the conference video image and the other screen displays a presentation.
T.120 Data Collaboration support	Data collaboration is defined by the T.120 standard. Data collaboration using T.120 over the video conference connection enhances the conference by providing the tools for conference participants to share data instantaneously.
Security and privacy	<ul style="list-style-type: none"> • Administrator and operator password protection for accessing the Cisco Unified Videoconferencing 3515 MCU web interfaces. • Optional PIN protection for joining a conference and web access. • Additional PIN protection for conference Chair Control. • The Cisco Unified Videoconferencing 3515 MCU uses H.235-based encryption to achieve secure communication with endpoints that support this standard.
In-conference control using DTMF or H.243	During a conference, participants may use their endpoint remote control or keypad to perform actions such as mute, volume control, changing video layouts and inviting participants. Users interact with the Cisco Unified Videoconferencing 3515 MCU via DTMF signaling or the onscreen GUI of H.243-compliant endpoints.
Optional no self see	The administrator can configure the Cisco Unified Videoconferencing 3515 MCU service to remove the self-view for each conference participant. This feature enables more effective use of the video screen.
IVR messages	The Cisco Unified Videoconferencing 3515 MCU includes pre-recorded greetings to conference participants and announcements as each new participant joins the conference. Using the Cisco Audio Message Utility, IVR messages can be recorded to provide custom greetings and announcements.

Port Capacities of the 3515 MCU12 and MCU24

The Cisco Unified Videoconferencing 3515 MCU12 and Cisco Unified Videoconferencing 3515 MCU24 are delivered with a predetermined number of ports.

The Cisco Unified Videoconferencing 3545 MCU supports switched High Definition (HD) video service types. HD services enable Voice Activated single-screen displays at up to 2 Mbps, and offer resolutions of 1280 x 720 pixels (720p) and 1920 x 1080 pixels (1080p).

HD service types also enable you to set a minimum downspeeding bandwidth rate which is common to all endpoints participating in a conference.

Cisco Unified Videoconferencing 3515 MCU12 Port Capacity

Cisco Unified Videoconferencing 3515 MCU12 supports a fixed number of ports as follows:

- 72 ports of fully transcoded audio.
- 18 ports of fully processed standard rate video (up to 384 Kbps)
- 12 ports of fully processed high rate video (up to 2Mbps).
 - Any Continuous Presence layout.
 - All ports are fully video processed.
 - Video and audio processing per user, not per conference. Each user connects using unique, optimized audio and video settings to enjoy the best audio and video quality supported by his/her endpoint and network.
 - Any mixture of H.261/H.263/H.264.
 - Mixed QCIF/CIF/4CIF conferences (4CIF is provided with H.263 at 15fps).
 - Unlimited number of conferences.



Note When using a High Definition Video service type, only a single screen is available.

Cisco Unified Videoconferencing 3515 MCU24 Port Capacity

Cisco Unified Videoconferencing 3515 MCU24 supports a fixed number of ports as follows:

- 72 ports of fully transcoded audio.
- 36 ports of fully processed standard rate video (up to 384 Kbps)
- 24 ports of fully processed high rate video (up to 2Mbps).
 - Any Continuous Presence layout.
 - All ports are fully video processed.
 - Video and audio processing per user, not per conference. Each user connects using unique, optimized audio and video settings to enjoy the best audio and video quality supported by his/her endpoint and network.
 - Any mixture of H.261/H.263/H.264;
 - Mixed QCIF/CIF/4CIF conferences (4CIF is provided with H.263 at 15fps).

- Unlimited number of conferences.

**Note**

When using a High Definition Video service type, only a single screen is available.

About Cisco Unified Videoconferencing 3515 MCU Architecture

The Cisco Unified Videoconferencing 3515 MCU enables both voice-only and video conference calls for H.323, SIP, H.320, SCCP and regular PSTN network telephones. H.323 and SIP devices can connect to a conference directly through the Cisco Unified Videoconferencing 3515 MCU. Other devices such as voice telephones and video conferencing terminals (H.320) can connect to a conference via a gateway, such as the Cisco Unified Videoconferencing 3500 Gateway.

Figure 1-1 Supported Devices and Protocols

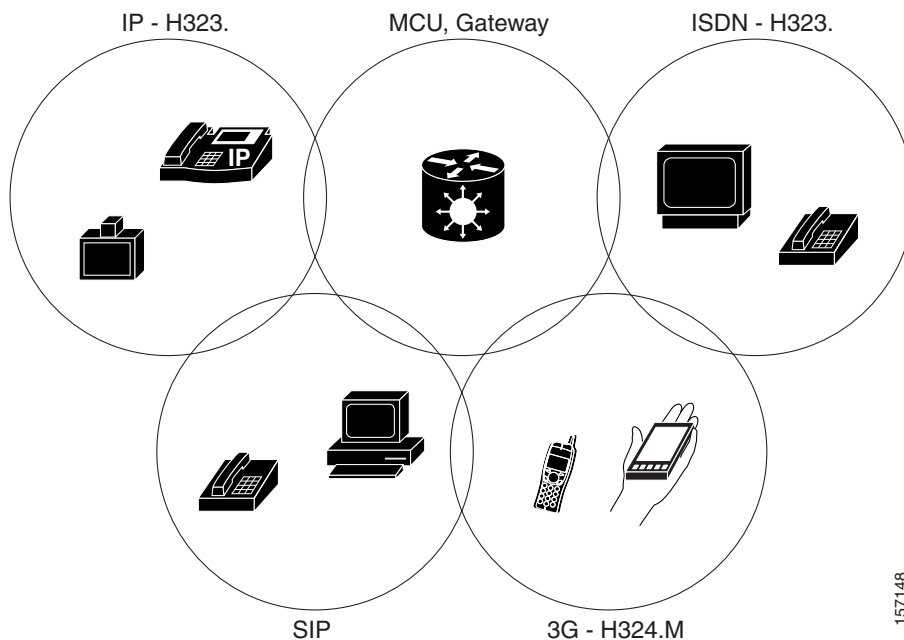

The Cisco Unified Videoconferencing 3515 MCU supports devices that can send and receive video streams, as well as those that cannot send but only receive video streams. This means that terminals without a video camera or video capturing capabilities can participate in a conference as voice-only participants while benefiting from seeing the other participants.

About Cisco Unified Videoconferencing 3515 MCU Topologies

The Cisco Unified Videoconferencing 3515 MCU can work in a centralized or cascaded topology. This section describes these two options.

Centralized Topology

In a centralized topology, the Cisco Unified Videoconferencing 3515 MCU performs media processing for all connected terminals. The Cisco Unified Videoconferencing 3515 MCU can handle multiple conferences simultaneously.

Figure 1-2 Centralized Topology

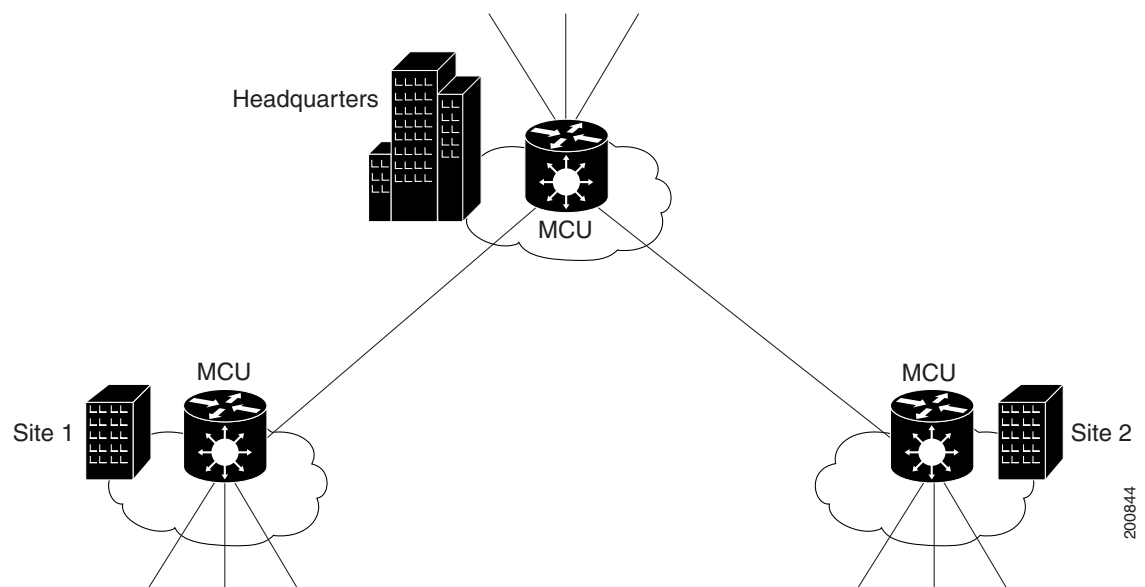

Cascaded Conferences

The Cisco Unified Videoconferencing 3515 MCU allows you to combine two or more conferences resulting in a larger conference with many more participants. This is called *cascading*. Cascading creates a distributed environment that helps reduce the drain on network resources. In addition, the processing resources required by the Cisco Unified Videoconferencing 3515 MCU are distributed between participating MCUs. Costly telephone or ISDN line usage can be further reduced with the mediation of a gateway.

Cascading occurs when one conference with “x” number of participants invites another conference with “y” number of participants. The two conferences effectively become one large conference. The bandwidth required across a cascaded conference link is only that of one audio/video stream between the two conferences. This is significantly less than the accumulated bandwidth of all the participants. Each separate Cisco Unified Videoconferencing 3515 MCU unit participating in a conference retains control of its individual conference resources and participants.

The cascaded conference in [Figure 1-3](#) minimizes the use of network bandwidth while distributing processing among the participating the Cisco Unified Videoconferencing 3515 MCU units.

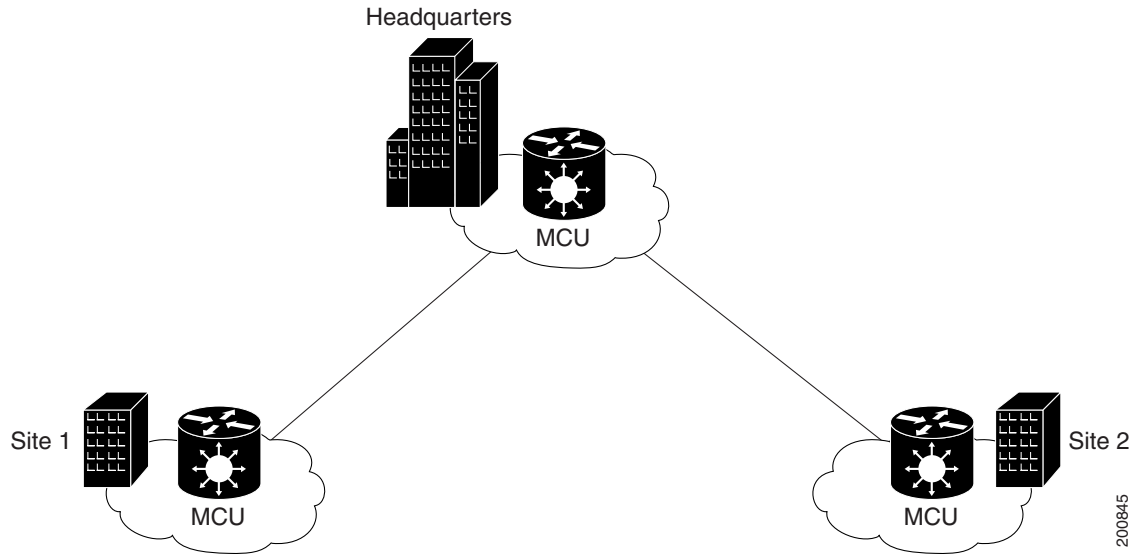
Figure 1-3 Cascaded Conference



Setting Up Your Cisco Unified Videoconferencing 3515 MCU

This section describes the following topics:

- [Physical Description of the Cisco Unified Videoconferencing 3515 MCU, page 2-1](#)
- [Preparing to Install the 3515 MCU, page 2-2](#)
- [Verifying the Package Contents of the 3515 MCU, page 2-3](#)
- [Mounting the Cisco Unified Videoconferencing 3515 MCU Unit in a 19-inch Rack, page 2-4](#)
- [Cisco Unified Videoconferencing 3515 MCU Unit Initial Configuration, page 2-5](#)
- [Video Processing Module Initial Configuration for the 3515 MCU, page 2-8](#)
- [Managing and Monitoring the Cisco Unified Videoconferencing 3515 MCU Unit, page 2-13](#)
- [Accessing the Cisco Unified Videoconferencing 3515 MCU Administrator Interface, page 2-14](#)
- [Registering the Online Help for the 3515 MCU, page 2-15](#)

Physical Description of the Cisco Unified Videoconferencing 3515 MCU

Each Cisco Unified Videoconferencing 3515 MCU unit internally contains two cards:

- Signaling and audio card (MCU—the upper card)
- Video processing card (EMP—the lower card)

The two cards work together to perform audio and videoconferencing, but each card requires a unique IP address. The cards communicate with each other using IP as the backbone.



Note

For correct operation, the EMP card must register with the MCU.

This section provides a physical description of the Cisco Unified Videoconferencing 3515 MCU12 and Cisco Unified Videoconferencing 3515 MCU24 units.

The Cisco Unified Videoconferencing 3515 MCU unit has a 10/100BaseT Ethernet port on the front panel that uses an RJ-45 connector to connect to the network. There is an asynchronous, 9-pin serial-port that you can use with a hyperterminal program to configure and monitor the module.

Figure 2-1 shows the front panel of the Cisco Unified Videoconferencing 3515 MCU unit. Table 2-1 describes the components of the front panel.

Figure 2-1 Cisco Unified Videoconferencing 3515 MCU Front Panel

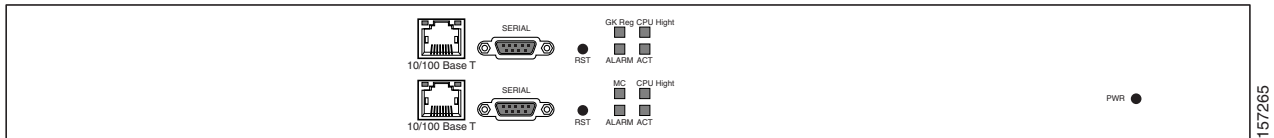

Table 2-1 Front Panel Components

Component	Description
10/100 BaseT connector	An RJ-45 connector that provides the primary Ethernet connection for the IP network port.
Serial connector	A DB-9 connector that allows you to connect a PC terminal for local configuration.
RST button	Allows you to reset the Cisco Unified Videoconferencing 3515 MCU unit manually.
GK Reg and MC LEDs	Lights green when the Cisco Unified Videoconferencing 3515 MCU unit is registered with a gatekeeper.
CPU High LED	Lights green when more than 50% of the Cisco Unified Videoconferencing 3515 MCU unit resources are in use.
ACT LED	Lights green to indicate that there is at least one currently active conference on the Cisco Unified Videoconferencing 3515 MCU unit.
ALARM LED	Lights green to indicate that an error has occurred and the Cisco Unified Videoconferencing 3515 MCU unit requires resetting.
10/100 BaseT LEDs	The top part of the 10/100 BaseT connector contains two LED indicators. The left-hand LED lights green when the local IP network link is active. The right-hand LED lights green if the connection speed is 100 Mbps, and is off when the connection speed is 10 Mbps.

Preparing to Install the 3515 MCU

This section describes the installation requirements for installing the Cisco Unified Videoconferencing 3515 MCU unit.

- Proper clearance at the sides of the unit to allow adequate ventilation, and at least 20 cm clearance at the back of the unit to allow access to cable connections
- A PC with a serial port and terminal emulation software to assign the Cisco Unified Videoconferencing 3515 MCU unit an IP address
- Two dedicated IP addresses—one each for the MCU and EMP units
- The IP address of the router that the Cisco Unified Videoconferencing 3515 MCU unit will use to communicate across the network
- For an H.323 environment, IP address of the H.323 gatekeeper with which you want the Cisco Unified Videoconferencing 3515 MCU unit to register

- For a Skinny Client Control Protocol (SCCP) environment, the IP address of the Trivial File Transfer Protocol (TFTP) server or Cisco Unified CallManager from which you want the Cisco Unified Videoconferencing 3515 MCU unit to get configuration information
- Available IP network ports on the switch for the Cisco Unified Videoconferencing 3515 MCU unit
- A grounded AC power outlet
- A 10BaseT or 100BaseT LAN cable
- Ambient room temperature range of 32° to 104°F (0° to 40°C)
- Non-condensing relative humidity range of 5% to 90%

Verifying the Package Contents of the 3515 MCU

Inspect the contents of the box for shipping damage. Report any damage or missing items to your Cisco representative. [Table 2-2](#) lists the package contents for the Cisco Unified Videoconferencing 3515 MCU unit.

Table 2-2 *Package Contents with Cisco Unified Videoconferencing 3515 MCU12 or Cisco Unified Videoconferencing 3515 MCU24 Unit*

Product	Contents
Cisco Unified Videoconferencing 3515 MCU unit	<ul style="list-style-type: none"> • Cisco Unified Videoconferencing 3515 MCU12 or Cisco Unified Videoconferencing 3515 MCU24 unit • Power cable (depending on customer location) • Terminal cable • Two LAN cables (one for the MCU, one for the video processing module) • Rack mounting kit (two brackets and six screws) • Four rubber feet • Guide to Cisco Conferencing Documentation • Regulatory Compliance and Safety Information for Cisco Unified Videoconferencing 3500 Products • Cisco Unified Videoconferencing Software CD-ROM • Cisco Information Package

Mounting the Cisco Unified Videoconferencing 3515 MCU Unit in a 19-inch Rack

You can optionally mount the Cisco Unified Videoconferencing 3515 MCU unit in a standard 19-inch rack. Two mounting brackets and a set of screws are included in the Cisco Unified Videoconferencing 3515 MCU unit shipping box.

Procedure

-
- Step 1** Disconnect all cables including the power cables.
 - Step 2** Place the Cisco Unified Videoconferencing 3515 MCU unit right-side up on a hard flat surface, with the front panel facing you.
 - Step 3** Position a mounting bracket over the mounting holes on each side of the Cisco Unified Videoconferencing 3515 MCU unit, as shown in [Figure 2-2](#).

Figure 2-2 Fitting a Bracket for Rack Mounting

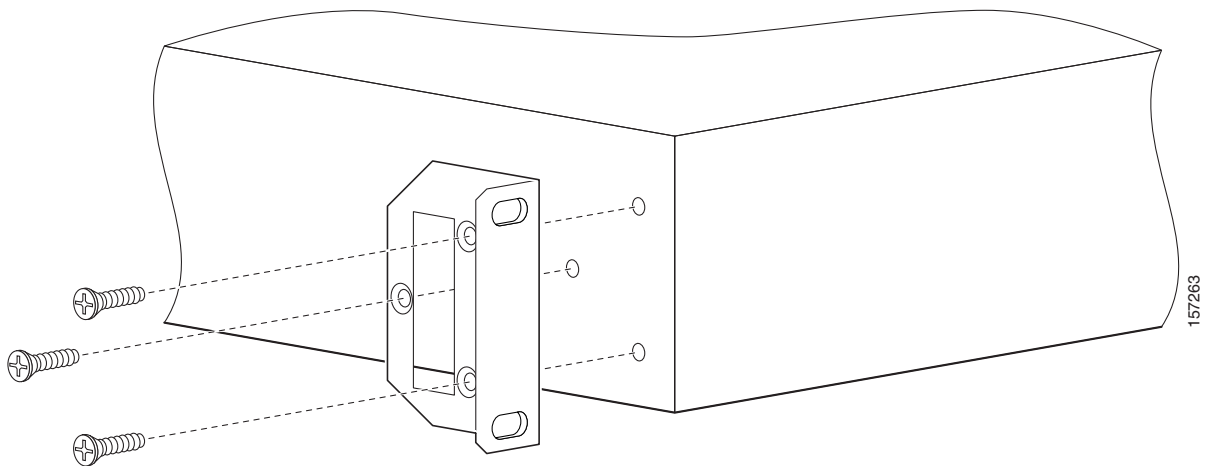

- Step 4** Pass the screws through the brackets and tighten them into the screw holes on each side of the Cisco Unified Videoconferencing 3515 MCU unit using a suitable screwdriver.
 - Step 5** Insert the Cisco Unified Videoconferencing 3515 MCU unit into the 19-inch rack.
 - Step 6** Fasten the brackets to the side rails of the rack.
 - Step 7** Make sure that the air vents at the sides of the Cisco Unified Videoconferencing 3515 MCU unit are not blocked.
-

Cisco Unified Videoconferencing 3515 MCU Unit Initial Configuration

Initial monitoring and administration of the Cisco Unified Videoconferencing 3515 MCU unit are performed from a remote PC via a serial connection. This allows you to access the boot configuration menu of the Cisco Unified Videoconferencing 3515 MCU unit. At power-up, the Cisco Unified Videoconferencing 3515 MCU unit goes through the following boot phases:

- Auto-boot—The embedded operating system initializes and displays basic information.
- Configuration menu—A six-second countdown allows you to enter the configuration menu.
- Initialization—The Cisco Unified Videoconferencing 3515 MCU unit completes its boot sequence and is ready for operation.

**Note**

You can perform serial port configuration of the Cisco Unified Videoconferencing 3515 MCU unit only at startup, during a short period indicated by a six-second countdown. Once the initialization phase is complete, the only way you can access the configuration menu is by restarting the Cisco Unified Videoconferencing 3515 MCU unit.

Connecting to a PC

This section describes how to use the serial port connection to configure the Cisco Unified Videoconferencing 3515 MCU unit with an IP address.

Procedure

- Step 1** Locate the terminal cable shipped with the Cisco Unified Videoconferencing 3515 MCU unit.
- Step 2** Connect the end labeled PC to the serial port on the computer.
- Step 3** Connect the end labeled Unit to the upper serial port connector on the Cisco Unified Videoconferencing 3515 MCU unit front panel.

**Note**

The PC terminal should have an installed terminal emulation application, such as HyperTerminal.

Setting the IP Address

This section describes how to use the serial port to configure the unit with an IP address and other address information.

The upper serial port on the Cisco Unified Videoconferencing 3515 MCU unit front panel is used to assign a new IP address to your Cisco Unified Videoconferencing 3515 MCU unit. You can assign the IP address before or after you connect the hardware to the network.

Before You Begin

Gather the items listed in [Table 2-3](#) to assign an IP address to the Cisco Unified Videoconferencing 3515 MCU unit.

Table 2-3 Requirements for Setting the IP Address

Requirements	Notes
Dedicated IP address for the Cisco Unified Videoconferencing 3515 MCU unit	
IP address of the default router the Cisco Unified Videoconferencing 3515 MCU unit uses to communicate over the network	
Subnet mask for the Cisco Unified Videoconferencing 3515 MCU unit if applicable	
Domain Name Server and domain name for Cisco Unified Videoconferencing 3515 MCU unit if applicable	
PC with available serial port and terminal emulator software installed	
RS-232 terminal cable (shipped with the unit)	

Procedure

-
- Step 1** Connect the RS-232 terminal cable to the PC terminal.
 - Step 2** Connect the power cable.
 - Step 3** Start the terminal emulation application on the PC.
 - Step 4** Set the communication settings in the terminal emulation application on the PC as follows:
 - Baud rate: 9600
 - Data bits: 8
 - Parity: None
 - Stop bits: 1
 - Flow control: None
 - Step 5** Turn on the power to the Cisco Unified Videoconferencing 3515 MCU unit.
A log of the auto-boot events appears on the computer.
 - Step 6** When the message “Press any key to start configuration” appears on the screen, press any key within six seconds.

The network configuration Main menu appears as follows:

```
Press any key to start configuration...
Main menu
N: Configure default network port values
P: Change the configuration software password
S: Configure network security level
A: Advanced configuration menu
Q: Quit

Select:
```



Caution If you do not press a key before the countdown ends, the device continues its initialization and you can only configure the device by pressing the RST button on the front panel.

Step 7 At the prompt, enter **N** to configure default network port values and press **Enter**.

Step 8 At the Enter IP address for Interface No. 1 prompt, enter the IP address you want to assign to the Cisco Unified Videoconferencing 3515 MCU unit and press **Enter**.



Caution Do not use leading zeros in the IP address.

Step 9 At the Enter Default Router IP Address prompt, enter the IP address of the router that you want the Cisco Unified Videoconferencing 3515 MCU unit to use and press **Enter**.



Caution Do not use leading zeros in the IP address.

Step 10 At the Enter IP Mask (HEX) prompt, enter the subnet mask as follows:

- Convert the subnet mask IP address to hexadecimal notation, enter the hexadecimal number at the prompt, and press **Enter**.

For example, for the subnet mask 255.255.255.0 the hexadecimal value you enter is FFFFFFF0.



Note You can use the desktop calculator on your computer to convert the subnet mask ID to hexadecimal notation.

- If a subnet mask is not used, press **Enter**.

After you enter the subnet mask parameter, the unit updates the boot line parameter and reboots.

Step 11 At the network configuration Main menu, enter **Q** to save your changes and allow the device to complete the boot process.



Caution Configuration of any of the parameters other than N: Configure default network port values may alter the function of the device and should not be performed by an unauthorized person.

Connecting the Cisco Unified Videoconferencing 3515 MCU Unit to the LAN

This section describes how to connect the Cisco Unified Videoconferencing 3515 MCU unit to the Local Area Network (LAN).

Procedure

-
- Step 1** Connect the supplied LAN cable from your network hub to the 10/100BaseT Ethernet port on the front panel of the Cisco Unified Videoconferencing 3515 MCU unit. The 10/100BaseT port accepts an RJ-45 connector.
- Step 2** Turn on the power to the Cisco Unified Videoconferencing 3515 MCU unit.
-

Video Processing Module Initial Configuration for the 3515 MCU

You must also configure an IP address for the video processing module. The IP address of the video processing module must be different than the IP address configured for the Cisco Unified Videoconferencing 3515 MCU unit.

Initial monitoring and administration of the video processing module are performed from a remote PC using a terminal emulation application, such as HyperTerminal. To make the serial connection, connect a PC terminal to the lower serial port on the front panel of the Cisco Unified Videoconferencing 3515 MCU unit as described in the [“Connecting to a PC” section on page 2-5](#). The serial configuration utility runs as a target configuration service. You can use the serial configuration utility to:

- Configure default network port values.
- Modify the configuration software password.
- Modify the Cisco Unified Videoconferencing 3515 MCU unit IP address.
- Modify advanced configuration settings such as the web server port and LAN port, and to restore the factory configuration.

Accessing the Video Processing Module Main Menu

You access the video processing module Main configuration menu in the same way as you access the Cisco Unified Videoconferencing 3515 MCU unit network configuration Main menu as described in the [“Procedure” section on page 2-6](#).

The video processing module Main configuration menu appears as follows:

```

Main menu
N: Configure default network port values
P: Change the configuration software password
S: Configure network security level
M: Change MCU ip address
A: Advanced configuration menu
Q: Quit

Select:
```

Setting the IP Address

This section describes how to use the serial port to configure the unit with an IP address and other address information.

The lower serial port on the Cisco Unified Videoconferencing 3515 MCU unit front panel is used to assign a new video processing module an IP address. You can assign the IP address before or after you connect the hardware to the network.

Procedure

Step 1 At the prompt, enter **N** to configure default network port values and press **Enter**.

Step 2 The default network properties screen appears as follows:

```
Enter IP Address for default Interface
Without leading zeros <172.20.35.110:ffff0000>
Enter Default Router IP Address for default Interface
Without leading zeros <current default Gateway IP address>:
```

Step 3 At the Enter IP address for default interface prompt, enter the IP address you want to assign to the video processing module followed by the subnet mask, in the format <IP address:subnet mask> and press **Enter**.



Note You must enter the subnet mask in the hexadecimal format.

Step 4 At the Enter Default Router IP Address prompt, enter the IP address of the default gateway that you want the video processing module to use and press **Enter**.

Allow the unit to complete the reboot process. A new emulator session begins.

Step 5 At the Main menu, do one of the following:

- Enter the letter for the set of parameters that you want to configure.
- Enter **Q** to save your changes and allow the device to complete the boot process.



Caution

Configuration of any of the parameters other than N: Configure default network port values may alter the function of the device and should not be performed by an unauthorized person.

Setting Ethernet Speed and Duplex Parameters

You can use the serial port to set the Ethernet speed and duplex parameters that you want the Cisco Unified Videoconferencing 3515 MCU to use.



Note

We recommend that you manually set these parameters on the Cisco Unified Videoconferencing 3515 MCU and switch to Ethernet speed 100 Mbps and full duplex.

Procedure

-
- Step 1** Access the Cisco Unified Videoconferencing 3515 MCU through the serial port and start a terminal emulator session.
-  **Note** If the Cisco Unified Videoconferencing 3515 MCU is already running, you need to reboot or restart the device.
-
- Step 2** When the message “Press any key to start configuration” appears on the screen, press any key within six seconds.
The network configuration Main menu appears.
- Step 3** At the prompt, enter **A** to display the Advanced Configuration menu and press **Enter**.
The Advanced Configuration menu appears.
- Step 4** At the prompt, enter **3** to select “Change LAN port Settings” and press **Enter**.
- Step 5** At the prompt, enter the number or letter for one of the following:
- **1** - 10Mbps Half Duplex
 - **2** - 100Mbps half Duplex
 - **3** - 10Mbps Full Duplex
 - **4** - 100Mbps Full Duplex
 - **5** - Auto
 - **Q** - Quit
- Enter this value to retain the current setting. The default setting is Auto.
- Step 6** Press **Enter**.
The network configuration Main menu appears.
- Step 7** At the Network Configuration menu, do one of the following:
- Enter the letter for the set of parameters that you want to configure.
 - Enter **Q** to save your changes and allow the device to complete the boot process.
-

Changing the Configuration Software Password

You can use the serial port to change the configuration software password.

Procedure

-
- Step 1** At the prompt, enter **P** to change the configuration software password and press **Enter**.
The user profile screen appears as follows:
- ```
Enter user name:
Enter new password:
```
- Step 2** At the Enter user name prompt, enter the new user name and press **Enter**.



- Step 3** At the Enter user password prompt, enter the new password and press any key to return to the video processing module Main menu.
- 

## Changing the Security Level

You can use the serial port to change the security level. Security levels are as follows:

- 0 (low)—Allows SNMP, Telnet, HTTP, FTP, and ICMP to access the MCU.
- 1 (medium)—Allows access to the MCU only through SNMP, HTTP and ICMP.
- 2 (high)—Allows only HTTP to access the MCU.

### Procedure

---

- Step 1** At the prompt, enter **S** to configure the network security level and press **Enter**.

The security level screen appears as follows:

```
The current security level is [0 low].
Enter a new security level (0-low, 1-medium, 2-high):
```

- Step 2** Enter the new security level required and press **Enter**.

The updated security level screen appears as follows:

```
The current security level is [0 low].
Enter a new security level (0-low, 1-medium, 2-high):
2
Board security level changing to [2 high]:
Set icmpRequestBlock to 2
The new security level is [2 high].
```

- Step 3** The video processing module Main menu displays.
- 

## Pointing the EMP to the Controlling Cisco Unified Videoconferencing 3515 MCU

You can use the serial port to point the EMP to the IP address of the controlling Cisco Unified Videoconferencing 3515 MCU unit.

### Procedure

---

- Step 1** At the prompt, enter **M** to change the Cisco Unified Videoconferencing 3515 MCU IP address and press **Enter**.

The Cisco Unified Videoconferencing 3515 MCU IP address screen displays as follows:

```
Enter MCU ip address
Without leading zeros <current IP address>:
```

- Step 2** Enter the IP address of the Cisco Unified Videoconferencing 3515 MCU and press any key to return to the EMP Main menu.
-

## Changing Advanced Configuration Settings

You can use the serial port to change the following advanced configuration settings:

- Web server port (for future use)
- Restore factory configuration (for future use)
- LAN port settings
- Disable DSP reset

### Procedure

**Step 1** At the prompt, enter **A** to access the **Advanced Configuration** menu.

The Advanced Configuration menu appears as follows:

```
Advanced configuration menu
Q: Quit
1: Configure web server port
2: Restore factory configuration
3: Change Lan port Settings
4: Disable DSP reset
```

Select:

**Step 2** At the prompt, enter **1** to configure the web server port.

The current web port server setting displays.

**Step 3** At the prompt, enter **2** to restore the factory configuration settings.

You are asked to confirm your choice as follows:

```
Select: 2
Are you sure you want to restore factory configuration? [y, n]:
```

**Step 4** Enter **y** or **n**.

**Step 5** At the prompt, enter **3** to change Ethernet speed and duplex parameters.

The network interface card settings screen appears as follows:

```
Choose : 1 - 10Mbps Half Duplex
 : 2 - 100Mbps Half Duplex
 : 3 - 10Mbps Full Duplex
 : 4 - 100Mbps Full Duplex
 : 5 - Auto
 other - Quit
:
```

**Step 6** Enter either a number between 0 and 5 inclusive, representing the required option.

**Step 7** Press any other key to quit without changing the network working mode.

**Step 8** At the prompt, enter **4** to disable the DSP reset facility.



#### Note

After options Q and 1-3, press any key to return to the video processing module Main menu. After option 4, the video processing module Main menu displays automatically.



#### Caution

Only qualified technical personnel should modify the DSP reset function settings.

## Saving Network Configuration Settings

Modified network configuration settings are automatically saved when you exit the video processing module Main menu.

### Procedure

- 
- Step 1** Ensure you have completed your configuration.
- Step 2** At the prompt, enter **Q** to exit the video processing module Main menu.
- The video processing module Main menu closes and your machine will automatically reboot.
- 

## Managing and Monitoring the Cisco Unified Videoconferencing 3515 MCU Unit

You can manage and monitor the Cisco Unified Videoconferencing 3515 MCU unit locally or from remote connections. You can also upgrade Cisco Unified Videoconferencing 3515 MCU software.

## SNMP Management

The Cisco Unified Videoconferencing 3515 MCU unit is equipped with an SNMP agent. You can access the Cisco Unified Videoconferencing 3515 MCU unit using an SNMP management client.

## Local Port Monitoring Connections

You should access the Cisco Unified Videoconferencing 3515 MCU unit using a local port connection for preliminary configuration and monitoring.

### Serial Port

The Cisco Unified Videoconferencing 3515 MCU unit includes a DB-9 serial port connector and an RJ-45 serial port connector. The DB-9 serial port is used to access the boot sequence menu from a local PC. Using a terminal emulation application running on the PC, you can assign an IP address and subnet mask to the Cisco Unified Videoconferencing 3515 MCU unit.

The RJ-45 serial port is used to connect a PC terminal to the Cisco Unified Videoconferencing 3515 MCU unit.

## Performing Software Upgrades

You can perform software upgrades by using the Cisco Upgrade Utility to upload files via a network or modem connection to the Cisco Unified Videoconferencing 3515 MCU unit. For more information, see [Chapter 3, “Using the Cisco Software Upgrade Utility”](#).

## Accessing the Cisco Unified Videoconferencing 3515 MCU Administrator Interface

The Cisco Unified Videoconferencing 3515 MCU Administrator is a web interface that allows you to configure general Cisco Unified Videoconferencing 3515 MCU unit settings, monitor Cisco Unified Videoconferencing 3515 MCU unit operation, create or edit services, manage media processor units and perform maintenance.

You access the Cisco Unified Videoconferencing 3515 MCU Administrator web interface in the Cisco Unified Videoconferencing 3515 MCU unit access window by signing in as an Administrator.

You can use your web browser from any remote PC station to monitor and to configure the Cisco Unified Videoconferencing 3515 MCU unit. A web server is installed in the Cisco Unified Videoconferencing 3515 MCU unit to facilitate the use of the remote web-based monitoring and management.

Access to the Cisco Unified Videoconferencing 3515 MCU configuration interface is controlled by a user name and a password. Once you have entered the settings you want, you should upload them to the unit for them to take effect, or you can save them to a configuration file to be loaded at a later time.

### Before You Begin

The following requirements are necessary to access the Cisco Unified Videoconferencing 3515 MCU Administrator web interface:

- A Java-compliant browser. Microsoft Internet Explorer version 5.5 or later is recommended.
- The Cisco Unified Videoconferencing 3515 MCU unit IP address or a web link to the Cisco Unified Videoconferencing 3515 MCU unit.
- The required user name and password.



### Note

For first-time installation, you must assign an IP address to the Cisco Unified Videoconferencing 3515 MCU unit using a serial port connection before you can access the web interface. For more information, see the [“Setting the IP Address”](#) section on page 2-6.

### Procedure

**Step 1** Launch your browser and enter the IP address or the name of the Cisco Unified Videoconferencing 3515 MCU unit followed by /admin.

For example, <http://125.221.23.44/admin> or **board\_name/admin**.

The Cisco Unified Videoconferencing 3515 MCU access window appears.

**Step 2** Enter the Administrator user name and password in the appropriate fields and click **Go**. The default global user name is *admin*. The default password is <null>.

The Cisco Unified Videoconferencing 3515 MCU Administrator interface appears.

**Note**

If you try to sign in as an Administrator and another Administrator is currently signed in, the Cisco Unified Videoconferencing 3515 MCU signs you in as a Read only user. The words *Read Only* appear at the top of the window and a pop-up displays the IP address of the Administrator already signed in. Read only users cannot edit any of the Cisco Unified Videoconferencing 3515 MCU settings.

## Registering the Online Help for the 3515 MCU

The online help files for the Cisco Unified Videoconferencing 3515 MCU Administrator and Conference Control interfaces are shipped on the Cisco Unified Videoconferencing Software CD-ROM. To use the online help, you must install the help files for the appropriate Cisco Unified Videoconferencing 3515 MCU in a shared directory on your network and register the directory location in the Administrator interface.

If you wish to install the online help on a shared network location and link it to the Cisco Unified Videoconferencing 3515 MCU Administrator, perform the following steps:

### Procedure

- Step 1** Copy the online help library from the Cisco Unified Videoconferencing Software CD-ROM to a shared folder on a PC on your network.
- Step 2** Log in to the Cisco Unified Videoconferencing 3515 MCU Administrator interface.
- Step 3** In the Online help URL field of the Device Web tab, enter the directory path to the help files you installed on your PC.  
The path must have the form:  
file://computerName/sharedDirectory  
where computerName is the name of the computer on the network and sharedDirectory is the path to the Online Help folder on the CD-ROM. For example:  
file://myComputer/Shared/Online Help
- Step 4** Click **Upload** in the Cisco Unified Videoconferencing 3515 MCU Administrator toolbar, followed by **Refresh**.
- Step 5** You may need to log out and log back in to the Cisco Unified Videoconferencing 3515 MCU Administrator for the change to take effect.

## Netscape Navigator Users

Online help files located on the local network and accessed using Netscape Navigator 4.x must be located on a mapped network drive.





# Using the Cisco Software Upgrade Utility

---

This section describes the following topics:

- [Introduction, page 3-1](#)
- [Launching the Cisco Software Upgrade Utility, page 3-1](#)
- [Upgrading Software, page 3-2](#)

## Introduction

The Cisco Software Upgrade Utility is an interactive GUI interface that enables you to upgrade Cisco software installed on Cisco devices.

The Cisco Software Upgrade Utility enables you to select files to be uploaded via a network or modem connection to the Cisco device. You can select either to perform a typical upgrade which includes all the new files or a customized upgrade which enables you to select which files to upload.

The upgrade files are uploaded and then burned into the memory of the Cisco device.

### Before You Begin

Cisco devices automatically save configuration settings before a software upgrade takes place. However, it is recommended that you save all configuration information using the Export button in the Cisco device web interface toolbar. You can retrieve all these settings after the software upgrade is complete by using the Import button in the Cisco device web interface toolbar.

## Launching the Cisco Software Upgrade Utility

This section describes how to install and launch the Cisco Software Upgrade Utility.

### Procedure

- 
- Step 1** Download the *UpgradeUtility.exe* file from the Cisco Unified Videoconferencing Software CD-ROM.
  - Step 2** Double click the *UpgradeUtility.exe* file to run the Software Upgrade Utility.  
The upgrade files are extracted and the Upgrade Utility dialog box appears.
-

# Upgrading Software

This section describes how to use the Software Upgrade Utility to upgrade Cisco software installed on Cisco devices.

## Procedure

---

- Step 1** In the General Information section of the Upgrade Utility dialog box, enter the IP address of the device you want to upgrade.
- Step 2** In the Login Information section, enter the administrator user name and password for the target device, as configured in the device network configuration settings.
- Step 3** (Optional) Modify the read and write community settings for the target device as follows:
- Click **Customize SNMP Settings**.
- The Customize SNMP Settings dialog box displays.
- Enter the required read community and write community values.



---

**Note** We recommend that you modify the default settings for security purposes.

---

- Click **OK** to return to the Upgrade Utility dialog box.
- Step 4** (Optional) Select the components of the target device you want to upgrade as follows:
- Click **Customize**.
- The Customize dialog box appears.
- Check the device components you want to upgrade in the Select the components you want to upgrade list.



---

**Note** The components displayed vary according to the Cisco device upgraded.

---

- Click **OK** to return to the Upgrade Utility dialog box.
- Step 5** Click **Upgrade** to upgrade all components of the Cisco device software (or only those components you manually selected via the Customize option).

The Cisco Software Upgrade Utility informs you whether or not the upgrade is successful.



---

**Note** When the upgrade is complete, the Cisco device automatically resets itself and starts operation with the new software version.

---





## Cisco Unified Videoconferencing 3515 MCU Cable Connections and Pin-outs

This section describes the following topics:

- [Unit RS-232 9-Pin Serial Port on the 3515 MCU, page 4-1](#)
- [RJ-45 8-Pin IP Network Port on the 3515 MCU, page 4-2](#)

### Unit RS-232 9-Pin Serial Port on the 3515 MCU

[Table 4-1](#) describes the Cisco Unified Videoconferencing 3515 MCU unit RS-232 9-pin D-type serial port pin-out configuration.

**Table 4-1** *RS-232 9-pin D-Type Serial Port Pin-out*

| Pin | Function | I/O    |
|-----|----------|--------|
| 1   | NC       |        |
| 2   | RXD      | Input  |
| 3   | TXD      | Output |
| 4   | NC       |        |
| 5   | GND      |        |
| 6   | NC       |        |
| 7   | NC       |        |
| 8   | NC       |        |
| 9   | NC       |        |

## RJ-45 8-Pin IP Network Port on the 3515 MCU

Table 4-2 describes the pin-out configuration of the RJ-45 IP network port.

**Table 4-2 Pin-out Configuration of the RJ-45 IP Network Port**

| <b>Pin</b> | <b>Function</b> | <b>I/O</b> |
|------------|-----------------|------------|
| 1          | TXD+            | Output     |
| 2          | TXD+            | Output     |
| 3          | RXD+            | Input      |
| 4          | NC              |            |
| 5          | NC              |            |
| 6          | RXD-            | Input      |
| 7          | NC              |            |
| 8          | NC              |            |



# Cisco Unified Videoconferencing 3515 MCU Technical Specifications

This section provides technical specifications for the Cisco Unified Videoconferencing 3515 MCU.

## Technical Specifications Table for the 3515 MCU

**Table 5-1** Cisco Unified Videoconferencing 3515 MCU Unit Technical Specifications

|                                 |                                                                                                                                                                                                                                                                                                                                                           |
|---------------------------------|-----------------------------------------------------------------------------------------------------------------------------------------------------------------------------------------------------------------------------------------------------------------------------------------------------------------------------------------------------------|
| <b>Unit Dimensions</b>          | <ul style="list-style-type: none"> <li>• Height: 1U (1.75 inches or 44.45 mm)</li> <li>• Width: 17.25 inches (438.15 mm)</li> <li>• Depth: 10 inches (254 mm)</li> <li>• Weight: 4.45 kg (9.81 lbs)—may vary according to configuration</li> </ul>                                                                                                        |
| <b>LED Indicators</b>           | <ul style="list-style-type: none"> <li>• 10/100 BaseT:               <ul style="list-style-type: none"> <li>– Link</li> <li>– Connection Speed</li> </ul> </li> <li>• GK Reg</li> <li>• CPU High</li> <li>• ALARM</li> <li>• ACT</li> <li>• MC (video processing module only)</li> </ul>                                                                  |
| <b>Push Buttons</b>             | <ul style="list-style-type: none"> <li>• RST</li> </ul>                                                                                                                                                                                                                                                                                                   |
| <b>Communication Interfaces</b> | <ul style="list-style-type: none"> <li>• Ethernet 10/100 Mbps auto-negotiate speed select</li> <li>• Asynchronous serial port RS-232 connected via 9-pin D-type connector</li> <li>• RJ-45 serial port (for video processing module)</li> <li>• SVGA port (for video processing module)</li> <li>• USB connector (for video processing module)</li> </ul> |
| <b>Chipset</b>                  | <ul style="list-style-type: none"> <li>• PowerPC MPC755 32-bit RISC microprocessor running at 400MHz or more</li> <li>• MPC8260 secondary microprocessor running at 200/133MHz or more</li> </ul>                                                                                                                                                         |

**Table 5-1** Cisco Unified Videoconferencing 3515 MCU Unit Technical Specifications (continued)

|                         |                                                                                                                                                                                                                      |
|-------------------------|----------------------------------------------------------------------------------------------------------------------------------------------------------------------------------------------------------------------|
| <b>Operating System</b> | <ul style="list-style-type: none"> <li>• RTOS, VxWorks 5.4</li> </ul>                                                                                                                                                |
| <b>Memory</b>           | <ul style="list-style-type: none"> <li>• 32 MB on-board flash memory for field upgrades, supports up to 64 MB</li> <li>• 1 MB L-2 Cache at 200 MHz or more</li> <li>• 128 MB SDRAM, supports up to 256 MB</li> </ul> |
| <b>Failsafe</b>         | <ul style="list-style-type: none"> <li>• Watchdog timer built in</li> </ul>                                                                                                                                          |
| <b>Power Supply</b>     | <ul style="list-style-type: none"> <li>• Input 100-240VAC autoswitched</li> <li>• Output + 3.3VDC, + 5VDC, + 12VDC</li> <li>• Maximum power load 150W</li> </ul>                                                     |



# Cisco Unified Videoconferencing 3515 MCU Safety

---

This section describes the following topics:

- [Electrical Safety for the 3515 MCU, page 6-1](#)
- [ESD Procedures for the 3515 MCU, page 6-2](#)

## Electrical Safety for the 3515 MCU

To avoid an electric shock or damage to the Cisco Unified Videoconferencing 3515 MCU unit, servicing should be performed by qualified service personnel only.

To reduce the risk of damaging power surges, Cisco recommends installing an AC surge arrestor in the AC outlet from which the Cisco Unified Videoconferencing 3515 MCU unit is powered.



**Warning**

---

**Do not attempt to open the Cisco Unified Videoconferencing 3515 MCU unit.**

---



**Warning**

---

**Changes or modifications to the device that are not approved by the party responsible for compliance could void the user's authority to operate the equipment.**

---

## Grounding

The power cable of the Cisco Unified Videoconferencing 3515 MCU unit should only be connected to a power outlet that has a protective earth contact. Do not use an extension cord that does not have a protective conductor (ground). The Cisco Unified Videoconferencing 3515 MCU unit can become dangerous if you interrupt any of the protective conductors (grounding) or disconnect any of the protective earth terminals.

## High Voltage

Disconnect the Cisco Unified Videoconferencing 3515 MCU unit from the power line before removing the cover. Avoid any adjustment, maintenance, or repair of an opened chassis under voltage. These actions should only be carried out by a skilled person who is aware of the dangers involved. Capacitors inside the chassis may still be charged, even if the unit has been disconnected from the power source.

## ESD Procedures for the 3515 MCU

To prevent damage to the Cisco Unified Videoconferencing 3515 MCU unit by random electrostatic discharge (ESD), the use of wrist straps is highly recommended.



# Cisco Unified Videoconferencing 3515 MCU Compliance and Certifications

---

This section describes the following topics:

- [Safety Compliance for the 3515 MCU, page 7-1](#)
- [EMC for the 3515 MCU, page 7-1](#)
- [Telecom for the 3515 MCU, page 7-2](#)
- [Environmental Compliance for the 3515 MCU, page 7-4](#)

## Safety Compliance for the 3515 MCU

This section lists the safety standards supported by the Cisco Unified Videoconferencing 3515 MCU unit.

- UL 60950
- CSA C22.2 No. 60950
- EN 60950
- TS 001
- AS/NZS 60950
- IEC 60950

## EMC for the 3515 MCU

This section lists the EMC compliance for the Cisco Unified Videoconferencing 3515 MCU unit.

- FCC Part 15 (CFR 47) Class A
- ICES-003 Class A
- EN 55022 Class A
- CISPR22 Class A
- AS/NZS CISPR22 Class A
- VCCI Class A
- CISPR24

- EN 55024
- EN 50082-1
- EN 61000-3-2
- EN 61000-3-3
- EN 61000-6-1



Warning

---

**This is a class A product. In a domestic environment this product may cause radio interference in which case the user may be required to take adequate measures.**

---

## FCC Part 15 Notice

This section provides RF interference information for the user.

This equipment has been tested and found to comply with the limits for a Class A digital device, pursuant to Part 15 of the FCC rules. These limits are designed to provide reasonable protection against harmful interference when the equipment is operated in a commercial environment. This equipment generates, uses, and can radiate radio frequency energy and, if not installed and used in accordance with the instruction manual, may cause harmful interference to radio communications. Operation of this equipment in a residential area is likely to cause harmful interference, in which case the user will be required to correct the interference at one's own expense.



Warning

---

**Changes or modifications to the device that are not approved by the party responsible for compliance could void the user's authority to operate the equipment.**

---

## Telecom for the 3515 MCU

- This section lists standards compliance for products that connect to ISDN lines.
- ACTA Part 68
- Industry Canada
- CE CTR3, CE CTR4

## ACTA Part 68 Notice

- 
- Step 1** This equipment complies with ACTA Part 68. On the cover of this equipment is a label that contains, among other information, the ACTA registration number. If requested, this information must be provided to the telephone company.
- Step 2** Applicable registration jack USOCs (Universal Service Order Codes) for the equipment is RJ48C for PRI interfaces and RJ49C for BRI interfaces.
- Step 3** An FCC compliant telephone cord and modular plug is provided with equipment. This equipment is designated to be connected to the telephone network or premises wiring using a compatible modular jack which is Part 68 compliant. See Installation Instructions for details.



- Step 4** If the terminal equipment Cisco Unified Videoconferencing 3515 MCU causes harm to the telephone network, the telephone company will notify you in advance that temporary discontinuance of service may be required. But if advance notice is not practical, the telephone company will notify the customer as soon as possible. Also, you will be advised of your right to file a complaint with the FCC if you believe it is necessary.
- Step 5** The telephone company may make changes in its facilities, equipment, operations or procedures that could affect the operation of the equipment. If this happens, the telephone company will provide advance notice in order for you to make necessary modifications to maintain uninterrupted service.
- Step 6** If trouble is experienced with the Cisco Unified Videoconferencing 3515 MCU equipment, please contact your Cisco representative for information on service or repairs. If the equipment is causing harm to the telephone network, the telephone company may request that you disconnect the equipment until the problem is resolved.
- Step 7** The Facility Interface Codes are: 04DU9-BN; 04DU9-DN; 04DU9-1SN. The Service Order Code is: 6.0N.
- Step 8** Only Cisco Systems, Inc. qualified service personnel may repair the equipment.
- 

## Industry Canada

The Industry Canada (IC) label identifies certified equipment. This certification means that the equipment meets certain telecommunications network protective, operational and safety requirements. The IC does not guarantee the equipment will operate to the user's satisfaction.

Before installing this equipment, users should ensure that it is permissible to be connected to the facilities of the local telecommunications company. The equipment must also be installed using an acceptable method of connection. In some cases, the company's inside wiring associated with a single line individual service may be extended by means of a certified connector assembly (telephone extension cord). The customer should be aware that compliance with the above condition may not prevent degradation of service in some situations.

Repairs to some certified equipment should be made by an authorized maintenance facility designated by the supplier. Any repairs or alterations made by the user to this equipment, or equipment malfunctions, may give the telecommunications company cause to request the user to disconnect the equipment.

Users should ensure for their own protection that the ground connections of the power utility, telephone lines and internal metallic water pipe system, are connected together. This precaution may be particularly important in rural areas.

The abbreviation, IC, before the registration number signifies that registration was performed based on a Declaration of Conformity indicating that Industry Canada technical specifications were met. It does not imply that Industry Canada approved the equipment.



### Warning

---

**Users should not attempt to make such connections themselves, but should contact the appropriate electric inspection authority, or electrician, as appropriate.**

---

# Environmental Compliance for the 3515 MCU

Cisco complies with the following EU Directives:

- Restrictions on the Use of Hazardous Substances (RoHS) Directive 2002/95/EC
- Waste Electrical and Electronic Equipment (WEEE) Directive 2002/96/EC



---

## Numerics

- 19-inch rack [2-4](#)
  - mount unit [2-4](#)
- 6-second countdown [2-5, 2-7](#)
- 9-pin serial-port [2-1](#)

---

## A

- ACT LED See LED indicators
- Administrator interface [1-2, 2-14](#)
- Advanced Configuration menu [2-8, 2-10, 2-12](#)
- architecture [1-6](#)
- audio
  - codecs [1-3](#)
- auto-boot [2-5](#)

---

## B

- boot configuration menu [2-5](#)

---

## C

- cables
  - RJ-45 8-pin IP network port [4-2](#)
  - RS-232 9-pin serial port [4-1](#)
- cascaded conferences [1-7](#)
- Certifications
  - EMC [7-1](#)
  - Telecom [7-2](#)
- chipset [5-1](#)
- codecs
  - audio transcoding [1-3](#)

- video [1-4](#)

- communication interfaces [5-1](#)
- communication settings [2-6](#)
- Conference Control interface [1-2](#)
- Configuration menu [2-5](#)
- Continuous Presence [1-4](#)

---

## D

- data collaboration [1-4](#)
- DB-9 [2-2, 2-13](#)
- DTMF [1-4](#)
- dual-screen video [1-4](#)
- Duo Video [1-4](#)
- duplex parameters [2-9, 2-12](#)

---

## E

- EMC [7-1](#)
- encryption [1-4](#)
- Ethernet
  - cable [2-3](#)
  - port [2-1](#)
  - speed [2-9, 2-12](#)

---

## F

- failsafe [5-2](#)
- flat capacity [1-2](#)
- front panel [2-2](#)
  - components [2-2](#)

**G**

GK LED See LED indicators  
 global user name [2-14](#)

**H**

H.235 [1-3](#)  
 H.239 [1-3, 1-4](#)  
 H.243 [1-4](#)  
 High Definition [1-5](#)

**I**

initial configuration [2-5](#)  
 initialization [2-5](#)  
 installation procedures
 

- access administrator interface [2-14](#)
- change advanced configuration settings [2-12](#)
- change configuration software password [2-8, 2-10](#)
- change IP address [2-8](#)
- change LAN port settings [2-12](#)
- change password [2-7](#)
- change security level [2-11](#)
- change unit IP address [2-11](#)
- configure default network port values [2-7, 2-8](#)
- configure IP address for unit [2-6](#)
- configure IP address for video processing module [2-9](#)
- configure network security level [2-7, 2-8](#)
- configure web server [2-12](#)
- configure web server port [2-12](#)
- connect to the serial port [2-5](#)
- connect unit to the LAN [2-8](#)
- disable DSP reset [2-12](#)
- display Advanced Configuration menu [2-8](#)
- display advanced configuration menu [2-7](#)
- mount unit in a 19-inch rack [2-4](#)
- restore factory configuration [2-12](#)
- restore factory settings [2-12](#)

save network configuration settings [2-13](#)  
 set default network properties [2-9](#)  
 set duplex parameters [2-10, 2-12](#)  
 set Ethernet speed [2-10, 2-12](#)  
 installation requirements [2-2](#)  
 interoperability [1-3](#)  
 IP address
 

- change for unit [2-11](#)
- configure for unit [2-6](#)
- configure for video processing module [2-9](#)

 IVR [1-4](#)

**L**

LAN cable [2-3](#)  
 layouts
 

- Continuous Presence [1-4](#)

 LED indicators [2-2, 5-1](#)  
 local port monitoring [2-13](#)

**M**

Main menu [2-8, 2-11, 2-12](#)  
 MC LED See LED indicators  
 memory [5-2](#)  
 multi-view See dual-screen video

**N**

Netscape Navigator [2-15](#)  
 Network Configuration menu [2-7, 2-8, 2-10](#)

**O**

online help [2-15](#)

- Netscape Navigator [2-15](#)

 operating system [5-2](#)  
 optional no self see [1-4](#)

**P**

- package contents [2-3](#)
- password
  - change configuration software password [2-10](#)
- pin-out configuration
  - RJ-45 IP network port [4-2](#)
  - RS-232 9-pin D-type serial port [4-1](#)
- ports
  - RJ-45 IP [4-2](#)
  - RS-232 9-pin serial [4-1](#)
- power supply [5-2](#)
- privacy [1-4](#)
- protocols [1-3](#)
- push buttons [5-1](#)

**R**

- remote control [1-4](#)
- remote management and monitoring [2-13](#)
- reset button [2-2](#)
- RJ-45 [2-2](#)
- RS-232 terminal cable [2-5](#)
- RST [2-2](#)
- RST button [5-1](#)

**S**

- Safety
  - compliance [7-1](#)
  - electrical [6-1](#)
  - ESD procedures [6-2](#)
- security [1-4](#)
  - change security level [2-11](#)
- self-view [1-4](#)
- serial connector [2-2](#)
- SNMP
  - agent [2-13](#)
- Software Upgrade Utility [2-14](#)

- software upgrade utility procedures
  - install and launch [3-1](#)
  - use utility [3-2](#)
- summary of features [1-2](#)

**T**

- T.120 [1-4](#)
- Telecom [7-2](#)
- terminal cable [2-5](#)
- topologies [1-7](#)
- transcoding [1-3](#)

**U**

- unit dimensions [5-1](#)
- upgrade software [3-1](#)
- user types [1-2](#)
  - administrators [1-2](#)
  - chair controllers [1-2](#)
  - conference participants [1-2](#)
  - operators [1-2](#)

**V**

- video
  - codec [1-4](#)
  - coding [1-4](#)
  - formats [1-4](#)
- video quality [1-2, 1-4](#)

**W**

- web-based management and control [1-3](#)
- web interface [2-14](#)



## Free Manuals Download Website

<http://myh66.com>

<http://usermanuals.us>

<http://www.somanuals.com>

<http://www.4manuals.cc>

<http://www.manual-lib.com>

<http://www.404manual.com>

<http://www.luxmanual.com>

<http://aubethermostatmanual.com>

Golf course search by state

<http://golfingnear.com>

Email search by domain

<http://emailbydomain.com>

Auto manuals search

<http://auto.somanuals.com>

TV manuals search

<http://tv.somanuals.com>