

# CHICAGO

## Electric<sup>®</sup>Generators

# GENERATOR SET

## 6.5 HP - RECOIL START - 2600W/2800W RATED

Model 92456

### OPERATING INSTRUCTIONS



3491 Mission Oaks Blvd., Camarillo, CA 93011  
Visit our Web site at <http://www.harborfreight.com>

**TO PREVENT SERIOUS INJURY OR DEATH,  
READ AND UNDERSTAND ALL WARNINGS  
AND INSTRUCTIONS BEFORE USE.**

Copyright© 2004 by Harbor Freight Tools®. All rights reserved. No portion of this manual or any artwork contained herein may be reproduced in any shape or form without the express written consent of Harbor Freight Tools.

**For technical questions and replacement parts, please call 1-800-444-3353**

## PRODUCT SPECIFICATIONS

Wattage	2,600 / 2,800 (Continuous-Rated/Peak)
Electrical Output	20 Amps @ 110/120 VAC, 60 Hz 10 Amps @ 12 VDC
Electrical Supply	Two 110/120 VAC, 3-Prong Grounding Outlets One 23 Amp Circuit Breaker
Voltmeter	0-150 Volts / 50 Volt Increments
Display Lights	Red (Run)
Generator Type	Brush-less / Revolving Field / Self Exciting Two Pole / Single Phase
Gasoline Engine	6.5 HP / Unleaded Gasoline Powered / Recoil Start / 4-Cycle OHV / Air-Cooled / 196 cc Displacement / 3600 RPM 0.63 Quart (0.6 Liter) Oil Capacity / CARB and EPA Certified
Fuel Tank Capacity	3.96 Gallons (15 Liters) / Includes Fuel Gauge
Estimated Run Time	7.8 Continuous Running Hours
Weight	112 Pounds

**This product requires oil and fuel to be added before starting. Attempting to start the engine without oil WILL ruin the engine and void the warranty.**

Caution: This generator is not intended to power sensitive electronic equipment without the addition of an appropriate line conditioner (sold separately).

The Emission Control System for this generator's engine is warranted for standards set by the U.S. Environmental Protection Agency and by the California Air Resources Board (also known as CARB). For warranty information, refer to the back two pages of this manual.

The engine's carburetor may need to be adjusted by a qualified mechanic for efficient high-altitude use.

## SAVE THIS MANUAL

You will need this manual for the safety warnings and precautions, operating, inspection, maintenance and cleaning procedures, parts list and assembly diagram. Keep your invoice with this manual. Write the invoice number on the inside of the front cover. Keep this manual and invoice in a safe and dry place for future reference.

---

## UNPACKING

---

When unpacking, check to make sure all the parts shown on the **Parts Lists on pages 18 and 20** are included. If any parts are missing or broken, please call Harbor Freight Tools at the number shown on the cover of this manual as soon as possible.

---

## GENERAL SAFETY RULES

---

 **WARNING!**

**READ AND UNDERSTAND ALL INSTRUCTIONS**  
**Failure to follow all instructions listed below may result in electric shock, fire, and/or serious injury.**  
**SAVE THESE INSTRUCTIONS**

### WORK AREA

1. **Keep your work area clean and well lit.** Cluttered benches and dark areas invite accidents.
2. **Do not operate power tools in explosive atmospheres, such as in the presence of flammable liquids, gases, or dust.** Generators create sparks which may ignite the dust or fumes.
3. **Keep bystanders, children, and visitors away while operating a generator.** Provide barriers or shields as needed.

### ELECTRICAL SAFETY

1. **Grounded tools must be plugged into an outlet properly installed and grounded in accordance with all codes and ordinances. Never remove the grounding prong or modify the plug in any way. Do not use any adapter plugs. Check with a qualified electrician if you are in doubt as to whether the outlet is properly grounded.** If the tools should electrically malfunction or break down, grounding provides a low resistance path to carry electricity away from the user.
2. **Double insulated tools are equipped with a polarized plug (one blade is wider than the other). This plug will fit in a polarized outlet only one way. If the plug does not fit fully in the outlet, reverse the plug. If it still does not fit, contact a qualified electrician to install a polarized outlet. Do not change the plug in any way.** Double insulation  eliminates the need for the three wire grounded power cord and grounded power supply system.

3. **Avoid body contact with grounded surfaces such as pipes, radiators, ranges, and refrigerators.** There is an increased risk of electric shock if your body is grounded.
4.  **Do not expose power tools to rain or wet conditions.** Water entering a generator will increase the risk of electric shock.
5. **Do not abuse the Power Cords. Never use a Power Cord to carry tools or pull the Plug from an outlet. Keep Power Cords away from heat, oil, sharp edges, or moving parts. Replace damaged Power Cords immediately.** Damaged Power Cords increase the risk of electric shock.
6. **When operating a power tool outside, use an outdoor extension cord marked “W-A” or “W”.** These extension cords are rated for outdoor use, and reduce the risk of electric shock.

### PERSONAL SAFETY

1. **Stay alert. Watch what you are doing, and use common sense when operating a generator. Do not use a generator while tired or under the influence of drugs, alcohol, or medication.** A moment of inattention while operating generators may result in serious personal injury.
2. **Dress properly. Do not wear loose clothing or jewelry. Contain long hair. Keep your hair, clothing, and gloves away from moving parts.** Loose clothes, jewelry, or long hair can be caught in moving parts.
3. **Avoid accidental starting. Make sure the Power Switch is in its “OFF” position, and disconnect the Spark Plug Wire when not in use.**
4. **Remove adjusting keys or wrenches before turning the generator on.** A wrench or a key that is left attached to a rotating part of the generator may result in personal injury.
5. **Do not overreach. Keep proper footing and balance at all times.**
6. **Use safety equipment. Always wear eye protection.** Wear ANSI approved safety impact eye goggles. Dust mask, nonskid safety shoes, hard hat, or hearing protection must be used for appropriate conditions.
7. **Do not force the generator. Use the correct generator for your application.** The correct generator will do the job better and safer at the rate for which it is designed.
8. **Do not use the generator if the Power Switch does not turn it on or off.** Any generator that cannot be controlled with the Power Switch is dangerous and must be replaced.

## GENERATOR USE AND CARE

1. **Make sure the Power Switch is in its “OFF” position and disconnect the spark plug wire before making any adjustments, changing accessories, or storing the generator.** Such preventive safety measures reduce the risk of starting the generator accidentally.
2. **Store idle generators out of reach of children and other untrained persons.** Generators are dangerous in the hands of untrained users.
3. **Maintain generators with care.** Do not use a damaged generator. Tag damaged generators “Do not use” until repaired.
4. **Check for misalignment or binding of moving parts, breakage of parts, and any other condition that may affect the generator’s operation. If damaged, have the generator serviced before using.** Many accidents are caused by poorly maintained generators.
5. **Use only accessories that are recommended by the manufacturer for your model.** Accessories that may be suitable for one generator may become hazardous when used on another generator.

## SERVICE

1. **Maintain labels and nameplates on the Generator and Engine.** These carry important information. If unreadable or missing, contact Harbor Freight Tools for a replacement.
2. **Generator service must be performed only by qualified repair personnel.** Service or maintenance performed by unqualified personnel could result in a risk of injury.
3. **When servicing a generator, use only identical replacement parts. Follow instructions in the “*Inspection, Maintenance, And Cleaning*” section of this manual.** Use of unauthorized parts or failure to follow maintenance instructions may create a risk of electric shock or injury.

## SPECIFIC PRODUCT WARNINGS AND PRECAUTIONS

### HEART PACEMAKER PRECAUTION

1.  **WARNING!** People with pacemakers should consult their physician(s) before using this product. Electromagnetic fields in close proximity to a heart pacemaker could cause interference to or failure of the pacemaker.

### INSTALLATION PRECAUTIONS

1. Ensure installation meets all applicable safety, and local and national electrical codes. Have installation performed by a qualified, licensed electrician and building contractor.
2. All electrical work, including the earth-ground connection, should be completed by a licensed electrician.
3. Any separate fuel storage Generator supply facility must be built or installed in full compliance with all relevant local, state, and federal regulations.
4.  If the generator is installed indoors, exhaust fumes must be piped out of the building using leak-free, heat-resistant piping. **Use the Generator only in well ventilated outdoor areas. Carbon monoxide fumes are a colorless, odorless gas that, if inhaled, can cause serious injury or death.** Pipes and silencer should not use any flammable materials, nor should they be installed near the same. Generator exhaust fumes must be within legal limits.
5. If the generator is installed outdoors, it must be weatherproofed and should be soundproofed. It should not be run outdoors without protection to the Generator and wiring conduit.
6. Never lift the Generator using the engine or alternator lifting lugs. Connect lifting equipment to the Frame of the Generator.
7. Before lifting the Generator, ensure the lift rigging and supporting structure are in good condition, and are rated to lift such a load.
8. Keep all personnel away from the suspended generator while relocating.
9. The supporting floor/ground surface should be level, and strong enough to safely hold the weight of the Generator. If the floor/ground surface is not level, strong cross members should be placed under the full length of the Generator Frame at its low side.

10. For trailer installation, the Generator should be mounted on the center point of the trailer, over the wheels.
11. Install sound and weather proofing only when it is not raining or snowing to avoid trapping moisture within the Generator's area.



### FIRE AND EXPLOSION PRECAUTIONS



1. Gasoline fuel and fumes are flammable, and potentially explosive. Use proper fuel storage and handling procedures. Always have multiple ABC class fire extinguishers nearby.
2. Keep the Generator and surrounding area clean at all times.
3. When spills of fuel or oil occur, they must be cleaned up immediately. Dispose of fluids and cleaning materials as per any local, state, or federal codes and regulations. Store oil rags in a covered metal container.
4. Never store fuel or other flammable materials near the Generator.
5. Do not smoke, or allow sparks, flames or other sources of ignition around the Engine and Fuel Tank. Fuel vapors are explosive.
6. Keep grounded conductive objects, such as tools, away from exposed, live electrical parts and connections to avoid sparking or arcing. These events could ignite fumes or vapors.
7. Do not refill the Fuel Tank while the Engine is running or while the Engine is still hot. Do not operate the Generator with known leaks in the fuel system.
8. Excessive buildup of unburned fuel gases in the exhaust system can create a potentially explosive condition. This buildup can occur after repeated failed start attempts, valve testing, or hot engine shutdown. If this occurs, open exhaust system drain plugs, if equipped, and allow the gases to dissipate before attempting to restart the Generator.
9. Use only engine manufacturer recommended fuel and oil.



## MECHANICAL PRECAUTIONS

1. **ALWAYS** make sure the Power Switch is in its “OFF” position. Disconnect the spark plug wire, and allow the Engine to completely cool before carrying out maintenance.
2. Check for damaged parts. Before using the Generator, any part that appears damaged should be carefully checked to determine that it will operate properly and perform its intended function. Check for alignment and binding of moving parts, any broken parts or mounting fixtures, and any other condition that may affect proper operation. Any part that is damaged should be properly repaired or replaced by a qualified technician.
3. The Generator is designed with guards for protection from moving parts. In any case, care must still be taken to protect personnel and equipment from other mechanical hazards when working around the generator.
4. Do not operate the Generator with safety guards removed. While the Generator is running, do not attempt to reach around the safety guards for maintenance or any other reason.
5. Keep hands, arms, long hair, loose clothing, and jewelry away from moving parts. Be aware that when engine parts are moving fast they cannot be seen clearly.
6. Keep access doors on enclosures closed and locked when access is not required.
7. When working on or around the Generator always wear protective clothing including ANSI approved safety gloves, safety eye goggles, and safety hat.
8. Do not alter or adjust any part of the Generator that is assembled and supplied by the manufacturer.
9. Always follow and complete scheduled Engine and Generator maintenance.

## CHEMICAL PRECAUTIONS

1. Avoid contact with hot fuel, oil, exhaust fumes, and solid surfaces.
2. Avoid body contact with fuels, oils, and lubricants used in the Generator. If swallowed, seek medical treatment immediately. Do not induce vomiting if fuel is swallowed. For skin contact, immediately wash with soap and water. For eye contact, immediately flush eyes with clean water.



## NOISE PRECAUTIONS

1. Prolonged exposure to noise levels above 85 dBA is hazardous to hearing. Always wear ANSI approved ear protection when operating or working around the Generator when it is running.

## ELECTRICAL PRECAUTIONS

1. All connections and conduits from the Generator to the load must only be installed by trained and licensed electricians, and in compliance with all relevant local, state, and federal electrical codes and standards, and other regulations where applicable.
2. The Generator must be earth-grounded in accordance with all relevant electrical codes and standards before operation.
3. If an extension cord (not included) is used, make sure to use only UL<sup>®</sup> listed cords having the correct gauge and length. **(See Figure A.)**

<b>REQUIRED MINIMUM EXTENSION CORD GAUGE – 120 VOLT</b>					
<b>NAMEPLATE AMPERES (At Full Load)</b>	<b>EXTENSION CORD LENGTH</b>				
	<b>0 - 25 Feet</b>	<b>25 - 50 Feet</b>	<b>50 -100 Feet</b>	<b>100 – 150 Feet</b>	<b>150– 200 Feet</b>
<b>0 - 5</b>	<b>16</b>	<b>16</b>	<b>16</b>	<b>12</b>	<b>12</b>
<b>5.1 - 8</b>	<b>16</b>	<b>16</b>	<b>14</b>	<b>10</b>	<b>-</b>
<b>8.1 - 12</b>	<b>14</b>	<b>14</b>	<b>12</b>	<b>-</b>	<b>-</b>
<b>12.1 - 15</b>	<b>12</b>	<b>12</b>	<b>10</b>	<b>-</b>	<b>-</b>
<b>15.1 - 20</b>	<b>10</b>	<b>10</b>	<b>10</b>	<b>-</b>	<b>-</b>

**FIGURE A**

4. Do not attempt to connect or disconnect load connections while standing in water, or on wet or soggy ground.
5. Do not touch electrically energized parts of the Generator and interconnecting cables or conductors with any part of the body, or with any non-insulated conductive object.
6. Connect the generator only to a load or electrical system (115 volt) that is compatible with the electrical characteristics and rated capacities of the Generator.
7. Before servicing equipment powered by the Generator, disconnect the equipment from its power input.

8. Keep all electrical equipment clean and dry. Replace any wiring where the insulation is cracked, cut, abraded or otherwise degraded. Replace terminals that are worn, discolored, or corroded. Keep terminals clean and tight.
9. Insulate all connections and disconnected wires.
10. Guard against electric shock. Prevent body contact with grounded surfaces such as pipes, radiators, ranges, and refrigerator enclosures.
11. Use only Class BC or Class ABC fire extinguishers on electrical fires.

## INSTALLATION

1. **NOTE:** Prior to powering tools and equipment, make sure the Generator's rated voltage, wattage, and amperage capacity (115 V - 20 Amps) is adequate to supply all electrical loads that the unit will power. If powering exceeds the Generator's capacity, it may be necessary to group one or more of the tools and/or equipment for connection to a separate Generator.
2. Electrical and other permits may be required for the installation of emergency power systems. Investigate the local building and electrical codes before installing this unit. Installation must be completed by licensed contractors.
3.  **WARNING!** The Generator is quite heavy. Use care and the proper lifting or hoisting equipment when moving it to the installation location. Always connect hoist lines to the Frame (41B) of the Generator.

## GENERAL LOCATION

1. It is recommended to locate and install the Generator outdoors where cooling air is readily available.
2. Install the Generator so that the air inlets and outlets are not blocked by obstructions such as bushes, trees, or snow drifts. Locating it in the path of heavy winds or snowdrifts may require the placement of a barrier for protection. The air inlet, in normal weather conditions, should face the prevailing wind direction.
3. Install the Generator on a concrete slab or other area where rain drainage or flood waters can not reach it.
4. Generator placement should allow four feet of access to all sides for maintenance.

5. Place the Generator as close as possible to the electrical tools and equipment being powered to reduce the length of extension cords.
6. If the Generator is located indoors the Engine exhaust must be ventilated to the outdoors using leakproof, heat resistant, flexible, metal, flex tubing.

## GENERATOR SUPPORT AND MOUNTING

1. Mount the Generator on a concrete slab capable of supporting the weight of the Generator. The slab must extend on all sides beyond the Frame (41B) by at least one foot. Contact a cement contractor for slab specifications if necessary. Attach the Frame to the concrete slab using 3/8" diameter expansion anchor bolts (not supplied).

## GROUNDING THE GENERATOR

1. **NOTE:** It is recommended that only a trained and licensed electrician perform this procedure.
2. Connect a #6 AWG grounding wire (not included) from the Ground Connector (8) on the Generator to a grounding rod (not included) that has been driven at least 24 inches deep into the earth. The grounding rod must be an earth-driven copper or brass rod (electrode) which can adequately ground the Generator. **(See Figure B, next page.)**

## OPERATING INSTRUCTIONS

**NOTE:** For additional references to the parts listed in the following pages, refer to the **Assembly Diagrams on pages 19 and 21.**

### **Pre-Start Checks:**

1. Check to make sure the Engine's Power Switch (2) is in its "**OFF**" position. **(See Figure B, next page.)**
2. **IMPORTANT!** Prior to first using the Generator, the Engine **MUST** be filled with approximately 3/4 (0.63) quart of a high quality SAE 10W-30 grade engine oil. To do so, unscrew and remove the Engine's Oil Dipstick (65A) located at the bottom of the Engine Crankcase. Fill the Engine's Crankcase until the oil level is level with the **upper marked line** on the Dipstick. Then, screw the Dipstick back into the Oil Fill Hole. **(See Figure C, next page.)**

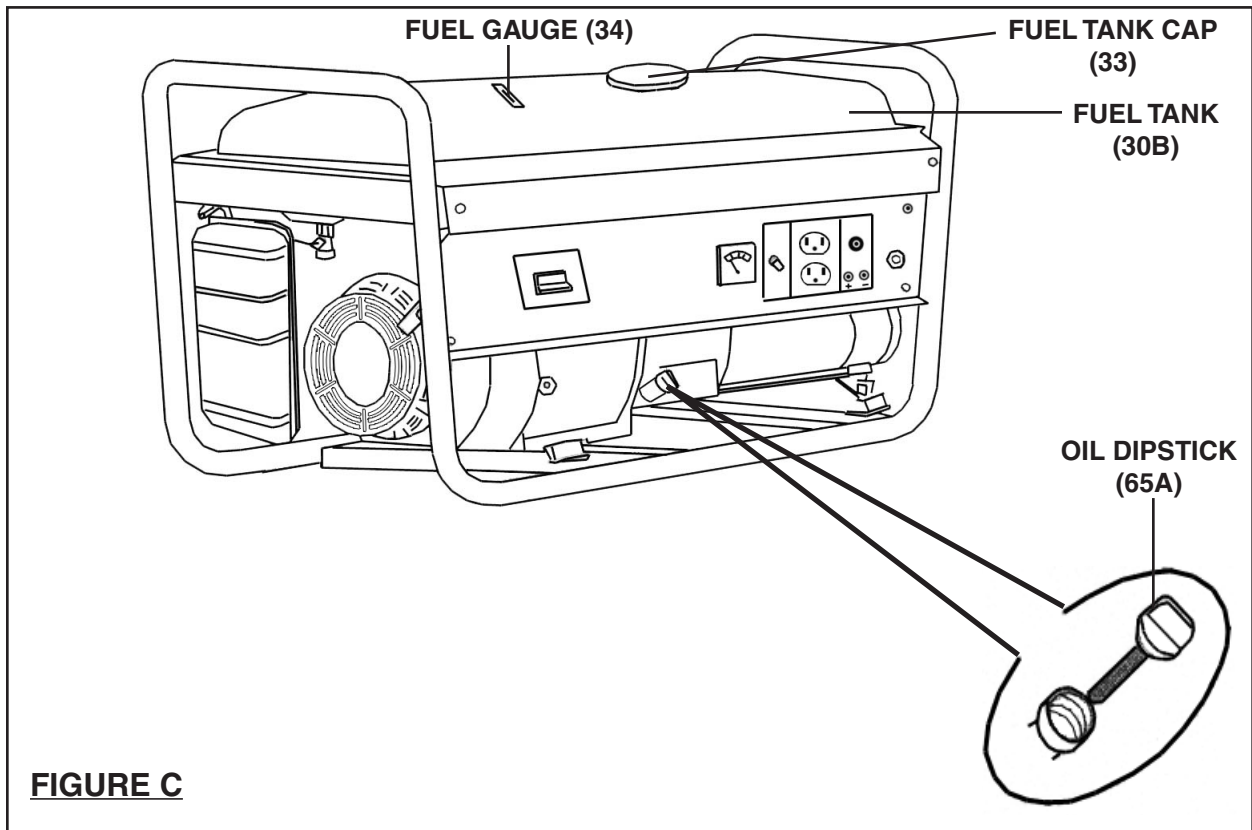
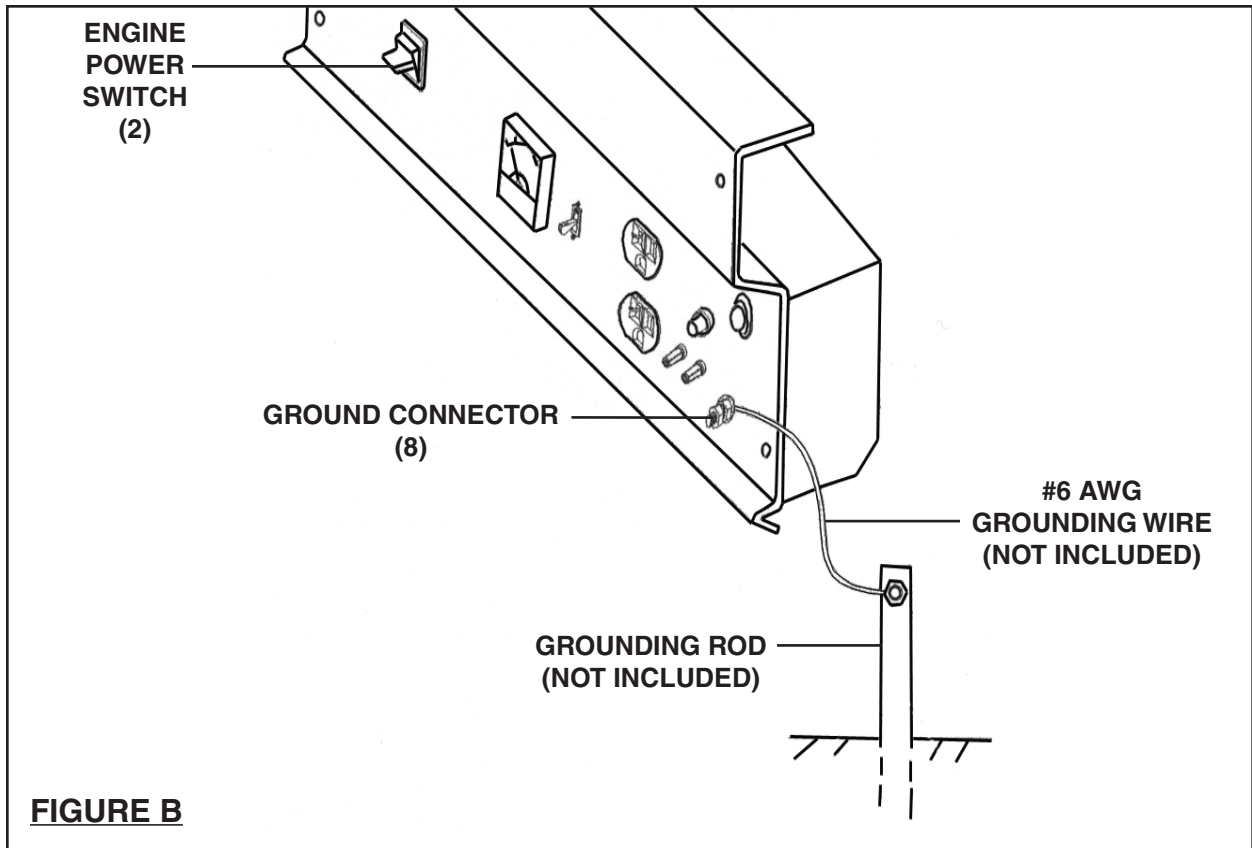

3. Before the first use, remove the Fuel Tank Cap (33) and fill the Fuel Tank (30B) with **unleaded** gasoline. Then, replace the Fuel Tank Cap. Thereafter, check the Engine's Fuel Gauge (34) for the amount of unleaded gasoline in the Fuel Tank. If necessary, refill the Fuel Tank with unleaded gasoline. **(See Figure C.)**

**To Start The Engine:**

1. Make sure the electrical powered tools/equipment that will be used **is not** plugged in to the Generator.
2. Turn the 115 volt AC Circuit Breaker (5) to its **"ON"** position. **(See Figure D.)**

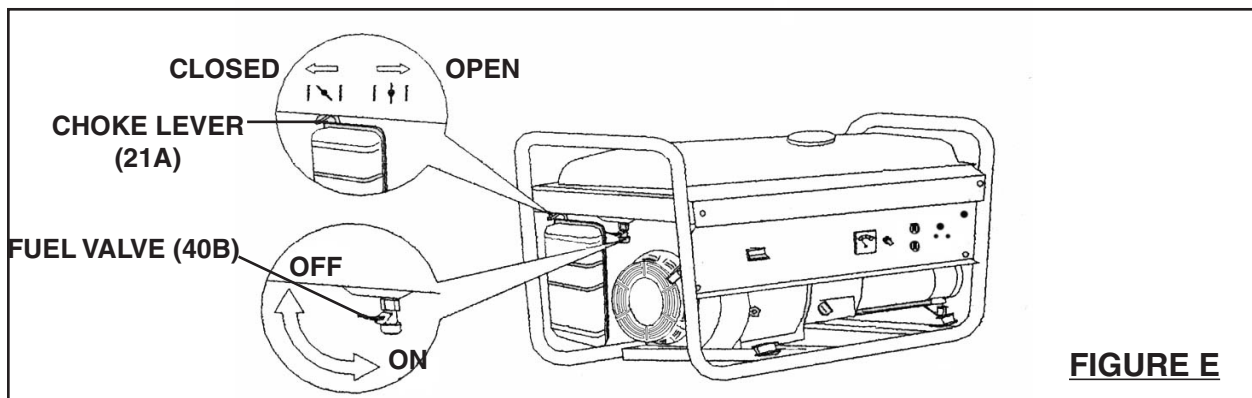
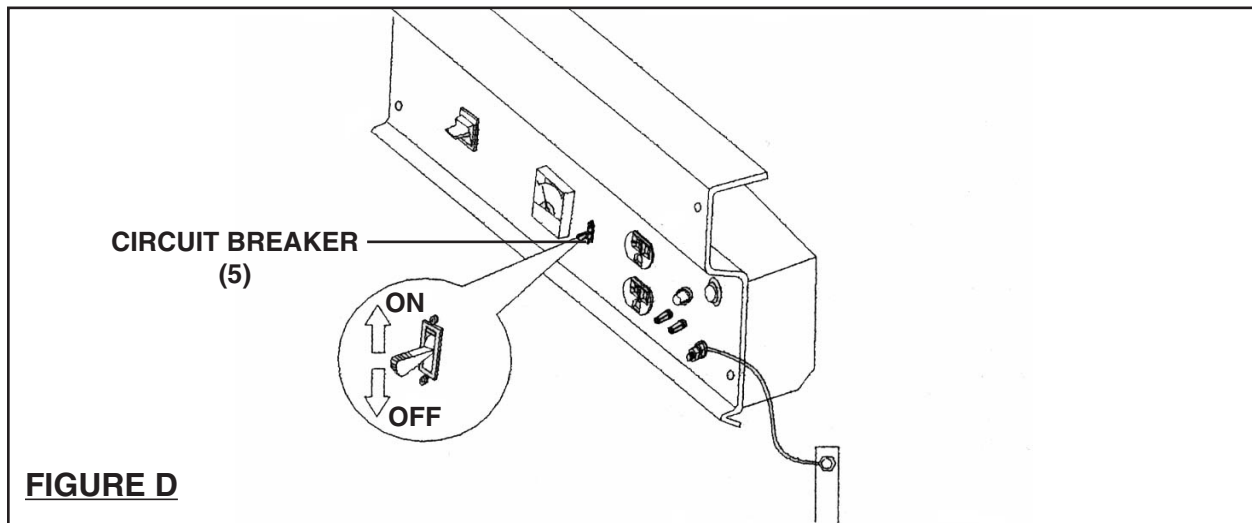

3. Turn on the Fuel Valve (40B). **(See Figure E.)**
4. Close the Choke Lever (21A) to about 1/8" clearance. **(See Figure E.)**

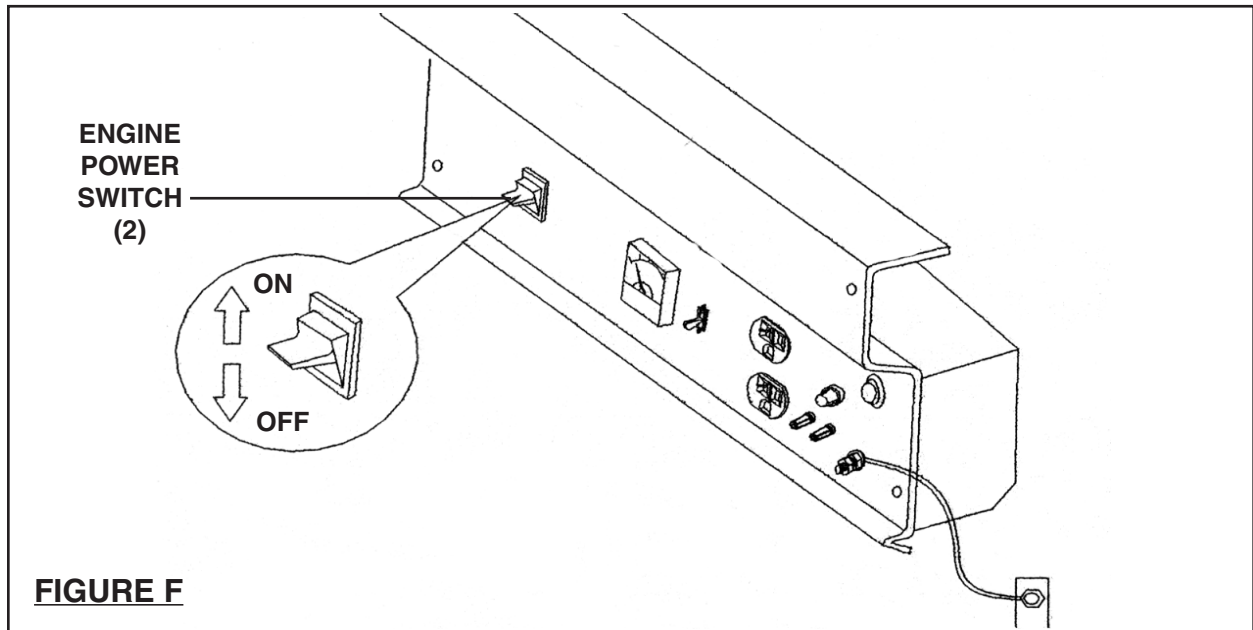

**FIGURE F**

5. Turn the Engine Power Switch (2) to its "ON" position. **(See Figure F.)**

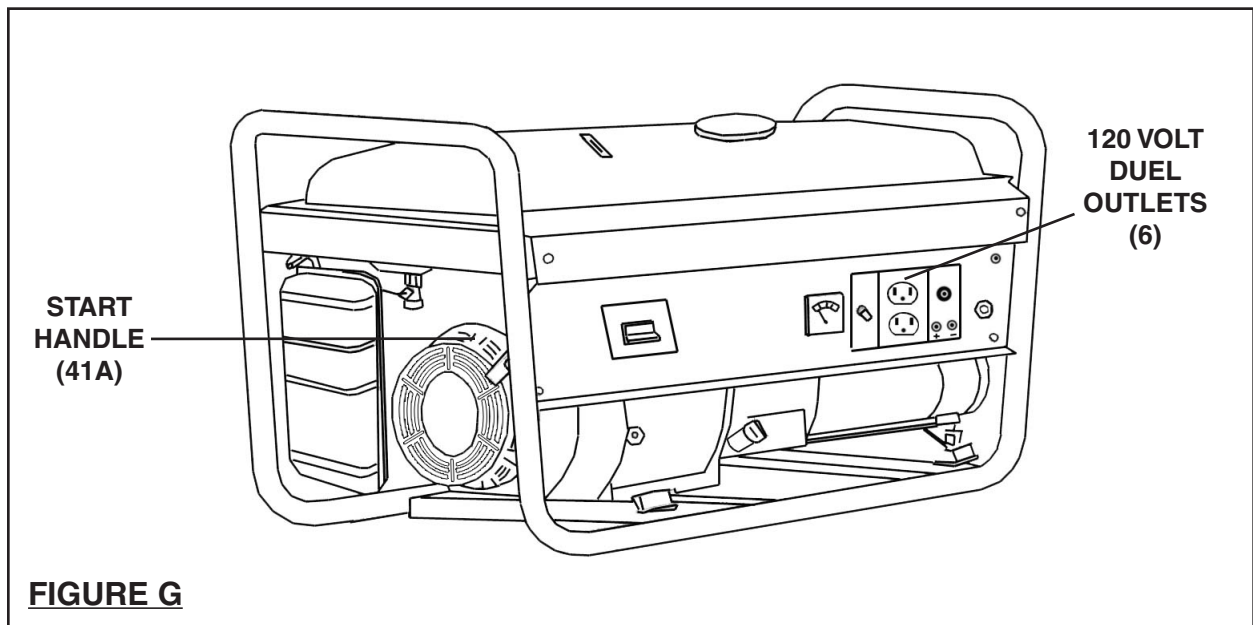

**FIGURE G**

6. Hold the Start Handle (41A) loosely and pull it slowly several times to allow the gasoline to flow into the Engine's carburetor. Then hold the Start Handle firmly and pull the rope hard and fast. Pull the rope all the way out, using two hands if necessary. If necessary pull the rope several times until the Engine starts. **(See Figure G.)**
7. Allow the Engine to run for several seconds. Then, open the Choke Lever (21A) all the way. **(See Figure E.)**

### **Powering 120 Volt AC Tools And Equipment:**

1. Prior to powering tools and equipment, make sure the Generator's rated voltage, and amperage capacity (**115 VAC / 20 Amps**) is adequate to supply all electrical loads that the unit will power. If powering exceeds the Generator's capacity, it may be necessary to group one or more of the tools and/or equipment for connection to a separate generator.
2. Once the Generator is running, simply connect the Power Cords of 115 volt AC powered tools and equipment into the 115 volt AC Dual Outlets (6).  
**(See Figure G.)**
3. **NOTE:** The Generator features an AC Non-Fuse Circuit Breaker (5) to protect the AC circuit in case of an overload. Should an overload occur the Breaker will "trip" to its "**OFF**" position, causing the Generator to automatically shut down. In this case, refer to Step #1 above in this section. Then, reset the circuitry system by turning the Circuit Breaker to its "**ON**" position. Restart the Generator and continue powering the remaining tools and equipment. **(See Figure D.)**
4. When finished using the Generator, turn the Engine Power Switch (2) to its "**OFF**" position. Turn the Fuel Valve (40B) to its "**OFF**" position. Then, disconnect all electrical powered tools and equipment from the Generator's 115 volt AC Dual Outlets (6). **(See Figures E, F, and G.)**
5. After the Engine and Generator have completely cooled, store the Generator in a safe, clean, dry location (if not already installed in one).

### **Powering 12 Volt DC Tools And Equipment:**

1. Prior to powering a tool or equipment, make sure the Generator's rated voltage, and amperage capacity (**12 VDC / 10 Amps**) is adequate to supply all electrical loads that the unit will power. If powering exceeds the Generator's capacity, it may be necessary to group one or more of the tools and/or equipment for connection to a separate generator.
2. Connect the Power Cord of a 12 VDC powered tool or equipment to the DC Terminals (7). **NOTE:** Make sure to connect the **positive (+)** lead of the Power Cord to the **positive (+)** Terminal on the Generator, and connect the **negative (-)** lead of the Power Cord to the **negative (-)** Terminal on the Generator.  
**(See Figure H, next page.)**
3. If using *only* a 12 volt DC tool or equipment, turn the 120 volt AC Circuit Breaker (5) to its "**OFF**" position. **(See Figure D.)**
4. Start and run the Engine as previously discussed in this manual.



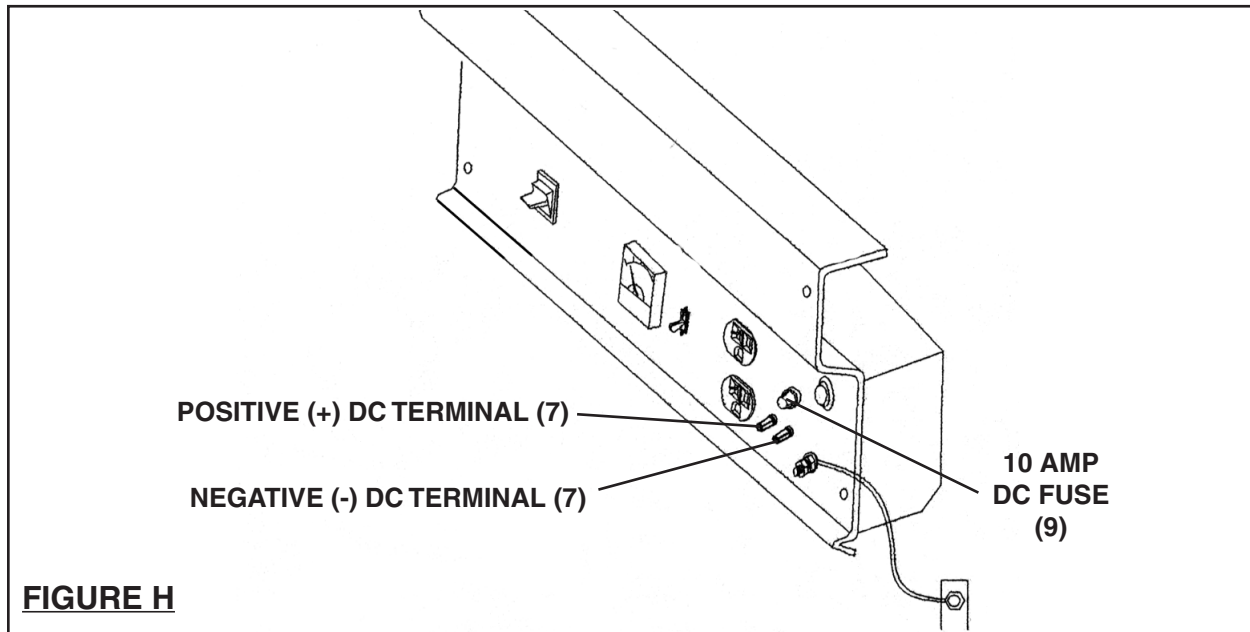

**FIGURE H**

5. When finished using the Generator, turn the Engine Power Switch (2) to its “**OFF**” position. Turn the Fuel Valve (40B) to its “**OFF**” position. Then, disconnect the electrical powered tool or equipment from the Generator’s DC Terminals (7). **(See Figure H.)**
6. After the Engine and Generator have completely cooled, store the Generator in a safe, clean, dry location (if not already installed in one).
7. **NOTE:** The Generator features a 10 AMP DC Fuse (9) to protect the DC circuit in case of an overload. Should an overload occur the Fuse will burn out, causing the Generator to automatically shut down. In this case, refer to Step #1 in this section. Then, reset the circuitry system by replacing the burnt Fuse with a new 10 AMP DC Fuse. Restart the Generator and continue powering the remaining tool or equipment. **(See Figure H.)**

---

## INSPECTION, CLEANING, AND MAINTENANCE

---

1. **CAUTION!** Always make sure the Engine Power Switch (2) is in its “**OFF**” position. Disconnect the spark plug wire from the engine and allow sufficient time for the Engine and Generator to completely cool before performing any inspection, maintenance, or cleaning.
2. **Before each use**, inspect the general condition of the Generator. Check for loose screws, misalignment or binding of moving parts, cracked or broken parts, damaged electrical wiring, and any other condition that may affect its safe operation. If abnormal noise or vibration occurs, have the problem corrected before further use. **Do not use damaged equipment.**

3. Follow all maintenance procedures as outlined in the **Engine Maintenance Schedule** below at the specified intervals. In addition, observe the following details:

**Before each use:** check to make sure the Engine's oil level is adequate. If necessary, fill the Engine's Crankcase until the oil level is even with the Oil Fill Hole.

**Before each use:** with a soft brush, cloth, or vacuum, remove all debris from the Generator and engine. Then, use a premium quality, lightweight machine oil to lubricate all moving parts.

**After the initial 20 hours of use and every 100 hours of use thereafter:** drain the old Engine oil and replace with approximately 3/4 (0.63) quart of a high quality SAE 10W-30 grade engine oil.

### Engine Maintenance Schedule

Interval (More frequent maintenance will be necessary in dusty or severe conditions.)	8 hours or daily, before use	50 hours or weekly	100 hours or biweekly	200 hours or monthly	500 hours or every 6 months	1000 hours or yearly	Details
Clean engine and check bolts & nuts							
Check and refill engine oil							
Change engine oil*							*Initial change immediately after 20 hour break-in period
Clean spark plug (28A)							
Clean and adjust spark plug (28A) electrodes							
Replace spark plug (28A)							
Clean air cleaner element (19A)							Wear dust mask and vacuum or blow clean with compressed air.
Replace air cleaner element (19A)							
Clean/replace fuel filter(s)^							^QUALIFIED TECHNICIAN/MECHANIC ONLY
Replace fuel lines and filter(s)^							^QUALIFIED TECHNICIAN/MECHANIC ONLY
Remove carbon from cylinder head (11A)^							^QUALIFIED TECHNICIAN/MECHANIC ONLY
Check and adjust valve clearance^							^QUALIFIED TECHNICIAN/MECHANIC ONLY
Clean and adjust carburetor^							^QUALIFIED TECHNICIAN/MECHANIC ONLY
Overhaul engine^							^QUALIFIED TECHNICIAN/MECHANIC ONLY

4. **Storage:** Before storing, drain all fuel out of the generator's gas tank. If this is not followed, old fuel in the generator's fuel tank may clog the generator and prevent it from starting until cleaned out.

## PARTS LIST

Part	Description	Qty.
1	Bolt (M6 x 12) w/Lock Washer	9
2	Engine Power Switch	1
3B	Control Panel	1
4	Voltmeter	1
5	Circuit Breaker	1
6	Outlet	2
7	DC Terminal	2
8	Ground Connector	1
9	DC Fuse	1
10	Pilot Light	1
11	Shock Absorber	4
12	Shock Absorber Foot	4
13	Lock Washer Nut	4
14	Stator Cover	1
15	Alternator Back Cover	1
16	Capacitor	1
17	Bolt (M5 x 16)	4
18	Rectifier	1
19	Bolt (M5 x 16)	3
20	Cable Sheath	1
21	Bolt (M8 x 242)	1
22	Bolt (M6 x 172)	4

Part	Description	Qty.
23	Bolt (M5 x 20)	4
24	Connection Board	1
25	Nut (M5)	4
26	Stator	1
27	Rotor	1
28	Cooling Fan	1
29	Heat Insulation Board	1
30B	Fuel Tank	1
31	Fuel Filter	1
32	Seal Ring	1
33	Fuel Tank Cap	1
34	Fuel Gauge	1
35B	Bolt (M6 x 12)	2
36	Lock Washer Bolt (M6 x 12)	4
37	Spacer	4
38	Rub Washer	4
39	Bush	4
40B	Fuel Valve	1
41B	Frame	1
42	Switch Box Cover	1
43	Engine	1

**NOTE:** Some parts are listed and shown for illustration purposes only, and are not available individually as replacement parts.

### PLEASE READ THE FOLLOWING CAREFULLY

THE MANUFACTURER AND/OR DISTRIBUTOR HAS PROVIDED THE PARTS LIST AND ASSEMBLY DIAGRAM IN THIS MANUAL AS A REFERENCE TOOL ONLY. NEITHER THE MANUFACTURER OR DISTRIBUTOR MAKES ANY REPRESENTATION OR WARRANTY OF ANY KIND TO THE BUYER THAT HE OR SHE IS QUALIFIED TO MAKE ANY REPAIRS TO THE PRODUCT, OR THAT HE OR SHE IS QUALIFIED TO REPLACE ANY PARTS OF THE PRODUCT. IN FACT, THE MANUFACTURER AND/OR DISTRIBUTOR EXPRESSLY STATES THAT ALL REPAIRS AND PARTS REPLACEMENTS SHOULD BE UNDERTAKEN BY CERTIFIED AND LICENSED TECHNICIANS, AND NOT BY THE BUYER. THE BUYER ASSUMES ALL RISK AND LIABILITY ARISING OUT OF HIS OR HER REPAIRS TO THE ORIGINAL PRODUCT OR REPLACEMENT PARTS THERETO, OR ARISING OUT OF HIS OR HER INSTALLATION OF REPLACEMENT PARTS THERETO.

# ASSEMBLY DIAGRAM

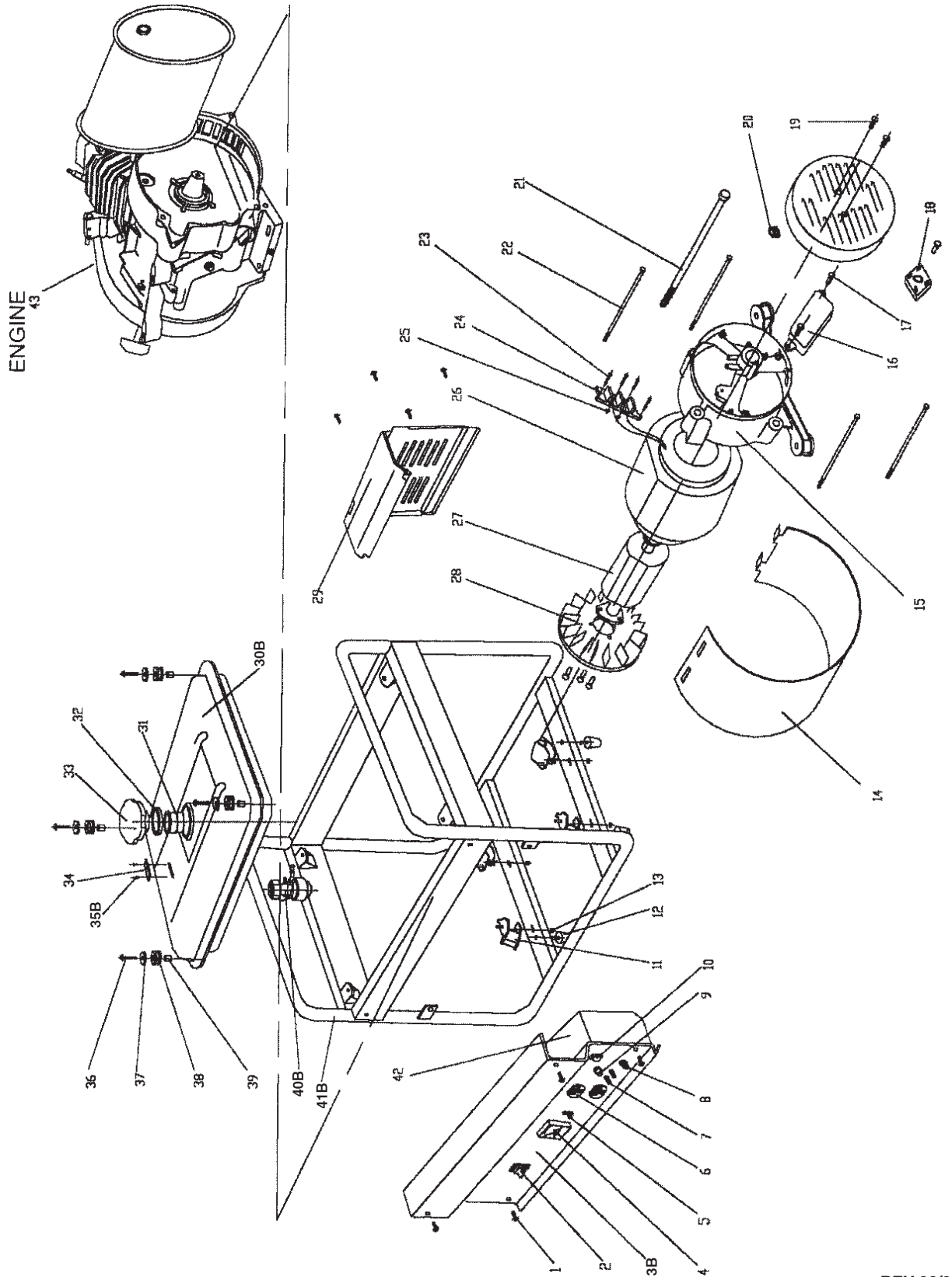

## PARTS LIST - CONTINUED

Part	Description	Qty.	Part	Description	Qty.
1A	Muffler	1	42B	Starting Case Assy.	1
2A	Cylinder Head Bolt	4	43A	Spiral Spring	1
3A	Cylinder Head Cover Bolt	4	44A	Starting Wheel	1
4A	Cylinder Head Cover	1	45A	C-clip	1
5A	Lock Nut	2	46A	Starting Ratchet	2
6A	Adjusting Screw	2	47A	Friction Plate Screw	1
7A	Rocker Arm	3	48B	Cover	1
8A	Rocker Arm Bolt	2	49A	Starter Pulley	1
9A	Valve Push Rod Guiding Board	1	50A	Cooling Fan	1
10A	Valve Push Rod	2	51A	Flywheel Magneto	1
11A	Cylinder Head	1	52A	Cylinder Block	1
12A	Carburetor Shield	1	53A	Speed Control Lever	1
13A	Carburetor Packing I	1	54A	Governor Arm	1
14A	Carburetor Assembly	1	55A	Governor Spring	1
15A	Air Cleaner Case	1	56A	Governor Support	1
16A	Air Cleaner Seal	1	57A	Bolt (M6 x 15)	2
17A	Bolt (M6)	4	58A	Oil Alert Nut	1
18A	Air Cleaner Cover	1	59A	Plug (M10 x 15)	2
19A	Air Cleaner Element	1	60A	Plug Washer	2
20A	Air Cleaner Separator	1	61A	Oil Alert	1
21A	Choke Lever	1	62A	Bolt (M6)	2
22A	Carburetor Packing II	1	63A	Crankshaft	1
23A	Stud Bolt (M6 x 109)	2	64A	Crankshaft Gear	1
24A	Intake Valve	1	65A	Oil Dipstick	2
25A	Exhaust Valve	1	66A	Oil Dipstick Seal Ring	2
26A	Cylinder Head Gasket	1	67A	Gear Casing	1
27A	Exhaust Pipe Stud	2	68A	Bolt (M8 x 35)	6
28A	Spark Plug	1	69A	Gear Case Packing	2
29A	Valve Guide	2	70A	Bearing	2
30A	Valve Spring	2	71A	Camshaft Assy.	1
31A	Rocker Shaft C-clip	2	72A	Locating Pin	4
32A	Anti-Wear Valve Stem Protector	2	73A	Oil Seal	2
33A	Cylinder Head Cover Packing	1	74A	Connecting Rod Bolt	2
34A	Governor Spring	1	75A	Connecting Rod Cap	1
35A	Bolt	1	76A	Connecting Rod	1
36A	High Tension Line	1	77A	Piston	1
37A	Ignition Coil	1	78A	Compression Ring I	1
38A	Nut (Special 14mm)	1	79A	Compression Ring II	1
39A	Starter Ratchet Spring	2	80A	Oil Scraper Ring	1
40A	Start Rope	1	81A	Piston Pin	1
41A	Start Handle	1	82A	Piston Pin C-clip	2

**NOTE:** Some parts are listed and shown for illustration purposes only, and are not available individually as replacement parts.



## WIRING DIAGRAM

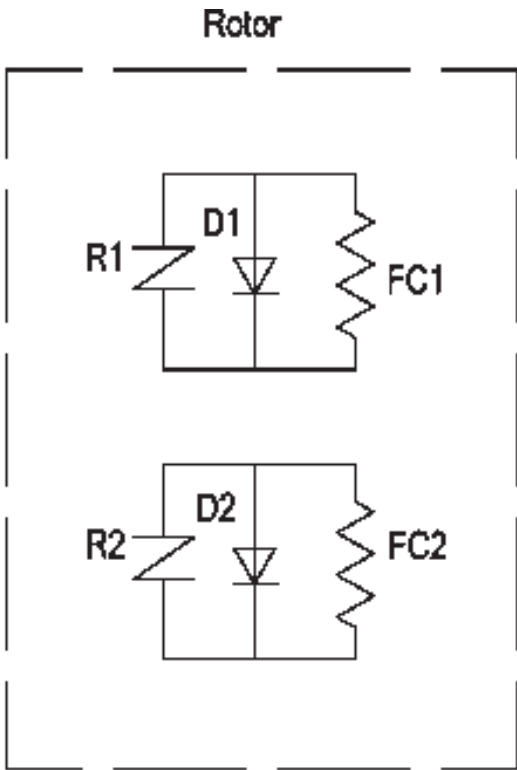

R1 Over Volt Protective  
R2 Resistance

D1 Spin Rectifier  
D2

FC1 Rotor Pole Winding  
FC2

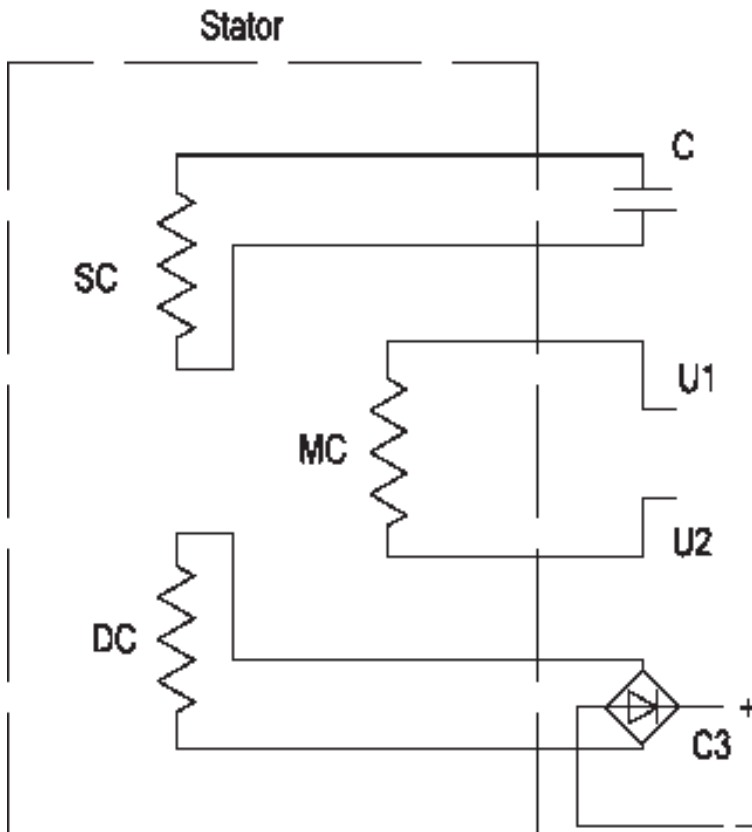

DC Stator DC Winding

C Capacitor

MC Stator Main Winding

D3 Single - phase Rectifier

SC Stator Auxiliary Winding





## Emission Control System Warranty

### California and United States Emission Control Defects Warranty Statement

The California Air Resources Board (herein CARB), the United States Environmental Protection Agency (herein EPA), and Harbor Freight Tools® (herein HFT) are pleased to explain the emission control system warranty on your 1995 and later Small Off-Road Engine (herein engine). In California, the engine must be designed, built and equipped to meet the State's stringent anti-smog standards. Elsewhere within the United States, new off-road, spark-ignition engines certified for model year 1997 and later, must meet similar standards set forth by the EPA. HFT must warrant the emission control system on your engine for the periods of time described below, provided there has been no abuse, neglect or improper maintenance of your engine.

Your emission control system may include parts such as the carburetor or fuel-injection system, and the ignition system. Also included may be hoses, belts, connectors and other emission-related assemblies.

Where a warrantable condition exists, HFT will repair your engine at no cost to you including diagnosis, parts and labor.

### Manufacturer's Warranty Coverage

The 1995 and later engines are warranted for two (2) years. If any emission-related part on your engine is defective, the part will be repaired or replaced by HFT.

### Harbor Freight Tools Emission Control

### Defects Warranty Coverage

Engines are warranted for a period of two (2) years relative to emission control parts defects, subject to the provisions set forth below. If any emission related part on your engine is defective, the part will be repaired or replaced by HFT.

### Owner's Warranty Responsibilities

- As the engine owner, you are responsible for the performance of the required maintenance listed in your Owner's Manual. HFT recommends that you retain all receipts covering maintenance on your engine, but HFT cannot deny warranty solely for the lack of receipts or for your failure to ensure the performance of all scheduled maintenance.
- As the engine owner, you should, however, be aware that HFT may deny you warranty coverage if your engine or a part has failed due to abuse, neglect, improper maintenance, or unapproved modifications.
- You are responsible for shipping your engine to a HFT warranty station as soon as a problem exists. Contact the HFT Customer Service department at the number below to make shipping arrangements. The warranty repairs should be completed in a reasonable amount of time, not to exceed 30 days.

If you have any questions regarding your warranty rights and responsibilities, you should contact the Harbor Freight Tools Customer Service Department at 1-800-444-3353.

# Emission Control System Warranty - continued

## Harbor Freight Tools Emission Control Defects Warranty Provisions

### **1. Length of Coverage**

HFT warrants to a first retail purchaser and each subsequent purchaser that the engine is free from defects in materials and workmanship that cause the failure of warranted parts for a period of two (2) years after the date of delivery to the first retail purchaser.

### **2. No Charge Repair or Replacement**

Repair or replacement of any warranted part will be performed at no charge to the owner if the work is performed through a warranty station authorized by HFT. For emissions warranty service, contact the HFT Customer Service Department at 1-800-444-3353.

### **3. Consequential Damages Coverage**

Coverage under this warranty shall also extend to the failure of any engine components caused by the failure of any warranted part while it is still covered under this warranty.

### **4. Coverage Exclusions**

Warranty claims shall be filed in accordance with the provisions of the HFT warranty policy explained in the box at the top of the previous page. HFT shall not be liable for any loss of use of the engine, for any alternative usage, for any damage to goods, loss of time, or inconvenience. Warranty coverage shall also be excluded for any part which fails, malfunctions, or is damaged due to failure to follow the maintenance and operating instructions set forth in the Owner's Manual including, but not limited to:

- (a) use of parts which are not authorized by HFT
- (b) improper installation, adjustment or repair of the engine or of any warranted part unless performed by an authorized warranty center
- (c) failure to follow recommendations on fuel use contained in the Owner's Manual
- (d) improper or inadequate maintenance of any warranted parts
- (e) repairs performed outside of the authorized warranty service dealers

- (f) alterations by changing, adding to or removing parts from the engine.

### **5. Service and Maintenance**

Component parts which are not scheduled for replacement as required maintenance or are scheduled only for regular inspection to the effect of "repair or replace as necessary" are warranted for the warranty period. Any warranted part which is scheduled for replacement as required maintenance is warranted for the period of time up to the first scheduled replacement point for that part. Any replacement part, provided it is equivalent in durability and performance, may be used in performance of maintenance or repairs. The owner is responsible for commissioning a qualified technician/mechanic to perform all required maintenance, as outlined in the **Inspection, Cleaning, and Maintenance** section on page 17 of this manual.

### **6. Warranted Parts**

- 1) Fuel Metering System**
  - i) Carburetor and its internal parts.
  - ii) Fuel pump (if so equipped).
  - iii) Cold start enrichment system.
- 2) Air Induction System**
  - i) Intake pipe/manifold.
  - ii) Air cleaner.
- 3) Ignition System**
  - i) Spark plug.
  - ii) Magneto ignition system.
- 4) Catalyst System (if so equipped)**
  - i) Exhaust pipe stud.
  - ii) Muffler.
  - iii) Catalytic converter (if so equipped).
- 5) Miscellaneous items Used in Above Systems**
  - i) Vacuum, temperature and time sensitive valves and switches.

## Free Manuals Download Website

<http://myh66.com>

<http://usermanuals.us>

<http://www.somanuals.com>

<http://www.4manuals.cc>

<http://www.manual-lib.com>

<http://www.404manual.com>

<http://www.luxmanual.com>

<http://aubethermostatmanual.com>

Golf course search by state

<http://golfingnear.com>

Email search by domain

<http://emailbydomain.com>

Auto manuals search

<http://auto.somanuals.com>

TV manuals search

<http://tv.somanuals.com>