

CHICAGO

Electric Generators

3050 RATED WATTS/3500 MAX. WATTS GASOLINE GENERATOR CERTIFIED IN CALIFORNIA

Model 67561

SET UP, OPERATING, AND SERVICING INSTRUCTIONS



⚠ DANGER

Using an engine indoors **CAN KILL YOU IN MINUTES.**

Engine exhaust contains carbon monoxide. This is a poison you cannot see or smell.



NEVER use inside a home or garage, **EVEN IF** doors and windows are open.

Only use **OUTSIDE** and far away from windows, doors, and vents.

Visit our website at: <http://www.harborfreight.com>



**Read this material before using this product.
Failure to do so can result in serious injury.
SAVE THIS MANUAL.**

Copyright© 2009 by Harbor Freight Tools®. All rights reserved. No portion of this manual or any artwork contained herein may be reproduced in any shape or form without the express written consent of Harbor Freight Tools. Diagrams within this manual may not be drawn proportionally. Due to continuing improvements, actual product may differ slightly from the product described herein. Tools required for assembly and service may not be included.

For technical questions or replacement parts, please call 1-800-444-3353.

CONTENTS

IMPORTANT SAFETY INFORMATION	3	EVERY 300 OPERATION HOURS:	16
AC APPLICATIONS	6	STORAGE	16
EXTENSION CORDS	7	ENGINE TROUBLESHOOTING	18
BASIC SPECIFICATIONS	8	EQUIPMENT TROUBLESHOOTING	20
FUNCTIONS	8	MAIN PARTS LIST	21
UNPACKING	8	MAIN ASSEMBLY DIAGRAM	22
CONTROLS	9	PARTS LIST AND DIAGRAM A - CRANKCASE ASSEMBLY	23
OPERATING INSTRUCTIONS	10	PARTS LIST AND DIAGRAM B - CYLINDER HEAD ASSEMBLY	24
STARTING THE ENGINE	10	PARTS LIST AND DIAGRAM C - CRANKSHAFT, PISTON, CONNECTING ROD, CAMSHAFT AND FLYWHEEL ASSEMBLIES	25
CHECKING AND FILLING ENGINE OIL	10	PARTS LIST AND DIAGRAM D - RECOIL STARTER AND IGNITION COIL ASSEMBLY	26
CHECKING AND FILLING FUEL	11	PARTS LIST AND DIAGRAM E - AIR CLEANER AND MUFFLER ASSEMBLY	27
START PROCEDURE	11	PARTS LIST AND DIAGRAM F - FUEL SUPPLY SYSTEM	27
BREAK-IN PERIOD	12	PARTS LIST AND DIAGRAM G - STARTER AND GENERATOR ASSEMBLY	28
EQUIPMENT OPERATION	12	WIRING DIAGRAM	29
CONTROL PANEL FEATURES	13	LIMITED 1 YEAR / 90 DAY WARRANTY	30
TECHNICAL SPECIFICATIONS ..	14	EMISSION CONTROL SYSTEM WARRANTY	30
SERVICING	14		
MAINTENANCE PROCEDURES	14		
ENGINE OIL CHANGE	14		
AIR FILTER ELEMENT MAINTENANCE	14		
SPARK PLUG MAINTENANCE ..	15		
CLEANING, MAINTENANCE, AND LUBRICATION SCHEDULE	16		
AFTER INITIAL 20 OPERATION HOUR PERIOD: ..	16		
EVERY 25 OPERATION HOURS THEREAFTER:	16		
EVERY 50 OPERATION HOURS:	16		
EVERY 100 OPERATION HOURS:	16		

SAVE THIS MANUAL

Keep this manual for the safety warnings and precautions, assembly, operating, inspection, maintenance and cleaning procedures. Write the product's serial number in the back of the manual near the assembly diagram (or month and year of purchase if product has no number). Keep this manual and the receipt in a safe and dry place for future reference.

IMPORTANT SAFETY INFORMATION

In this manual, on the labeling, and all other information provided with this product:



This is the safety alert symbol. It is used to alert you to potential personal injury hazards. Obey all safety messages that follow this symbol to avoid possible injury or death.

⚠ DANGER DANGER indicates a hazardous situation which, if not avoided, will result in death or serious injury.

⚠ WARNING WARNING indicates a hazardous situation which, if not avoided, could result in death or serious injury.

⚠ CAUTION CAUTION, used with the safety alert symbol, indicates a hazardous situation which, if not avoided, could result in minor or moderate injury.

NOTICE NOTICE is used to address practices not related to personal injury.

CAUTION CAUTION, without the safety alert symbol, is used to address practices not related to personal injury.



WARNING! Read all instructions. Failure to follow all instructions listed below may result in fire, serious injury and/or DEATH. The warnings and precautions discussed in this manual cannot cover all possible conditions and situations that may occur. It must be understood by the operator that common sense and caution are factors which cannot be built into this product, but must be supplied by the operator.

SAVE THESE INSTRUCTIONS

SET UP PRECAUTIONS

1. Gasoline fuel and fumes are flammable, and potentially explosive. Use proper fuel storage and handling procedures. Do not store fuel or other flammable materials nearby.
2. Have multiple ABC class fire extinguishers nearby.
3. Operation of this equipment may create sparks that can start fires around dry vegetation.

- A spark arrestor may be required. The operator should contact local fire agencies for laws or regulations relating to fire prevention requirements.
4. Set up and use only on a flat, level, well-ventilated surface.
 5. Wear ANSI-approved safety goggles, heavy-duty work gloves, and dust mask/respirator during set up.
 6. Use only oil and fuel recommended in the "Specifications" section of this manual.
3. Do not leave the equipment unattended when it is running. Turn off the equipment (and remove safety keys, if available) before leaving the work area.
 4. Wear ANSI-approved safety goggles and hearing protection during use.
 5. People with pacemakers should consult their physician(s) before use. Electromagnetic fields in close proximity to a heart pacemaker could cause pacemaker interference or pacemaker failure. Caution is necessary when near the engine's magneto or recoil starter.
 6. Use only accessories that are recommended by Harbor Freight Tools for your model. Accessories that may be suitable for one piece of equipment may become hazardous when used on another piece of equipment.

OPERATING PRECAUTIONS

1.  **CARBON MONOXIDE HAZARD**
Using an engine indoors CAN KILL YOU IN MINUTES.

Engine exhaust contains carbon monoxide. This is a poison you cannot see or smell.



NEVER use inside a home or garage, **EVEN IF** doors and windows are open.

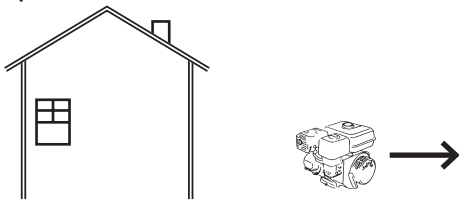

Only use **OUTSIDE** and far away from windows, doors, and vents.

2. Keep children away from the equipment, especially while it is operating.
7. Do not operate in explosive atmospheres, such as in the presence of flammable liquids, gases, or dust. Gasoline-powered engines may ignite the dust or fumes.
8. Stay alert, watch what you are doing and use common sense when operating this piece of equipment. Do not use this piece of equipment while tired or under the influence of drugs, alcohol or medication.
9. Do not overreach. Keep proper footing and balance at all times. This enables better control of the equipment in unexpected situations.
10. Use this equipment with both hands only. Using equipment with only one hand can easily result in loss of control.
11. Dress properly. Do not wear loose clothing or jewelry. Keep hair, clothing and gloves away from moving parts. Loose clothes, jewelry or long hair can be caught in moving parts.

12. Parts, especially exhaust system components, get very hot during use. Stay clear of hot parts.
13. Do not cover the engine or equipment during operation.
14. Keep the equipment, engine, and surrounding area clean at all times.
15. Use the equipment, accessories, etc., in accordance with these instructions and in the manner intended for the particular type of equipment, taking into account the working conditions and the work to be performed. Use of the equipment for operations different from those intended could result in a hazardous situation.
16. Do not operate the equipment with known leaks in the engine's fuel system.
17. This product contains or, when used, produces a chemical known to the State of California to cause cancer and birth defects or other reproductive harm. (California Health & Safety Code § 25249.5, *et seq.*)
18. When spills of fuel or oil occur, they must be cleaned up immediately. Dispose of fluids and cleaning materials as per any local, state, or federal codes and regulations. Store oil rags in a bottom-ventilated, covered, metal container.
19. Keep hands and feet away from moving parts. Do not reach over or across equipment while operating.
20. Before use, check for misalignment or binding of moving parts, breakage of parts, and any other condition that may affect the equipment's operation. **If damaged, have the equipment serviced before using.** Many accidents are caused by poorly maintained equipment.
21. Use the correct equipment for the application. Do not modify the

equipment and do not use the equipment for a purpose for which it is not intended.

22. **CAUTION:** This generator is not intended to power sensitive electronic equipment* without the addition of an appropriate line conditioner and surge protector (both not included). Sensitive electronic equipment should be operated on approved inverter type generators or pure sine wave generators.

If the plugged in product operates abnormally or unusually slow, immediately stop using the generator as a power source. Always read and adhere to the instruction manual of the product to be powered, to make sure that it can be safely and efficiently powered by a portable generator.

Note: When using a generator to provide home standby electricity, a transfer switch (sold separately) is needed to prevent back feeding power into the utility line.

Connections for standby power to a building electrical system must be made by a qualified electrician. The connection must isolate the generator power from utility power, and must comply with all applicable laws and electrical codes.

WARNING: Improper connections to a building electrical system can allow electrical current from the generator to backfeed into the utility lines. Such backfeed may electrocute utility company workers or others who contact the lines during a power outage, and the generator may explode, burn, or cause fires when utility power is restored. Consult the utility company or a qualified electrician.

***Sensitive electronic equipment includes, but is not limited to, audio/video equipment, some television sets, computers, and printers.**

AC APPLICATIONS

1. Before connecting an appliance or power cord to the generator: Make sure that it is in good working order. Faulty appliances or power cords can create a potential for electrical shock.
2. If an appliance begins to operate abnormally, becomes sluggish or stops suddenly, turn it off immediately. Disconnect the appliance, and determine whether the problem is the appliance, or if the rated load capacity of the generator has been exceeded.
3. Make sure that the electrical rating of the tool or appliance does not exceed that of the generator. Never exceed the maximum power rating of the generator. Power levels between rated and maximum may be used for no more than 30 minutes.
4. Substantial overloading will open the circuit breaker. Exceeding the time limit for maximum power operation or slightly overloading the generator may not switch the circuit breaker or circuit protector OFF, but will shorten the service life of the generator.
3. **Do not alter or adjust any part of the equipment or its engine that is sealed by the manufacturer or distributor. Only a qualified service technician may adjust parts that may increase or decrease governed engine speed.**
4. Wear ANSI-approved safety goggles, heavy-duty work gloves, and dust mask/respirator during service.
5. Maintain labels and nameplates on the equipment. These carry important information. If unreadable or missing, contact Harbor Freight Tools for a replacement.
6. Have the equipment serviced by a qualified repair person using only identical replacement parts. This will ensure that the safety of the equipment is maintained. Do not attempt any service or maintenance procedures not explained in this manual or any procedures that you are uncertain about your ability to perform safely or correctly.
7. Store equipment out of the reach of children.
8. Follow scheduled engine and equipment maintenance.
9. Refueling Precautions:
 - a. Do not smoke, or allow sparks, flames, or other sources of ignition around the equipment, especially when refuelling.
 - b. Do not refill the fuel tank while the engine is running or hot.
 - c. Do not fill fuel tank to the top. Leave a little room for the fuel to expand as needed.
 - d. Refuel in a well-ventilated area only.

SERVICE PRECAUTIONS

1. **Before service, maintenance, or cleaning:**
 - a. **Turn the engine switch to its "OFF" position.**
 - b. **Allow the engine to completely cool.**
 - c. **Then, remove the spark plug wire(s) from the spark plug(s).**
2. Keep all safety guards in place and in proper working order. Safety guards include muffler, air cleaner, mechanical guards, and heat shields, among other guards.



SAVE THESE INSTRUCTIONS.

Extension Cords

1. *Grounded* tools require a three wire extension cord. *Double Insulated* tools can use either a two or three wire extension cord.
2. As the distance from the supply outlet increases, you must use a heavier gauge extension cord. Using extension cords with inadequately sized wire causes a serious drop in voltage, resulting in loss of power and possible tool damage.
(See Table A.)
3. The smaller the gauge number of the wire, the greater the capacity of the cord. For example, a 14 gauge cord can carry a higher current than a 16 gauge cord.
(See Table A.)
4. When using more than one extension cord to make up the total length, make sure each cord contains at least the minimum wire size required.
(See Table A.)
5. If you are using one extension cord for more than one tool, add the nameplate amperes and use the sum to determine the required minimum cord size.
(See Table A.)
6. If you are using an extension cord outdoors, make sure it is marked with the suffix "W-A" ("W" in Canada) to indicate it is acceptable for outdoor use.
7. Make sure the extension cord is properly wired and in good electrical condition. Always replace a damaged extension cord or have it repaired by a qualified electrician before using it.
8. Protect the extension cords from sharp objects, excessive heat, and damp or wet areas.

RECOMMENDED MINIMUM WIRE GAUGE FOR EXTENSION CORDS* (120/240 VOLT)					
NAMEPLATE AMPERES (at full load)	EXTENSION CORD LENGTH				
	25 Feet	50 Feet	75 Feet	100 Feet	150 Feet
0 – 2.0	18	18	18	18	16
2.1 – 3.4	18	18	18	16	14
3.5 – 5.0	18	18	16	14	12
5.1 – 7.0	18	16	14	12	12
7.1 – 12.0	18	14	12	10	-
12.1 – 16.0	14	12	10	-	-
16.1 – 20.0	12	10	-	-	-

TABLE A * Based on limiting the line voltage drop to five volts at 150% of the rated amperes.

BASIC SPECIFICATIONS

Fuel	Type	91+ octane premium unleaded gasoline
	Capacity	4 Gallons
Engine Oil	Type	SAE 10W-30 above 32°F SAE 5W-30 at 32°F or below
	Capacity	2/3 Quart with Low Oil Shutdown Sensor
Spark Plug Gap		0.024" - 0.031"
Run Time @ 50% Load		9 Hours with full tank
Engine Type		7 HP Four-stroke Overhead Valve Design
Ignition		Recoil Start with Electronic Ignition
Electrical Outlets		One 20A duplex NEMA 120V~receptacle
		One 25A NEMA 120V 3 prong twist lock receptacle
		One T-Type 12V outlet (10A DC Breaker)

Note: Additional specifications found in the TECHNICAL ENGINE SPECIFICATIONS chart in this manual.

The emission control system for this engine is warranted for standards set by the U.S. Environmental Protection Agency and by the California Air Resources Board (also known as CARB). For warranty information, refer to the last pages of this manual.

At high altitudes, the engine's carburetor, governor (if so equipped), and any other parts that control the fuel-air ratio will need to be adjusted by a qualified technician to allow efficient high-altitude use and to prevent damage to the engine and any other devices used with this product.

Functions

This unit can power items such as the following:

ITEM	RUNNING WATTS	START-UP WATTS
Belt Sander	1200	2400
Refrigerator/Freezer	700	2200
1/2 HP Sump Pump	1050	2150
1/2 HP Well Pump	1000	2100
Miter Saw	1650	3000
1-1/2 HP Capacitor Start & Run Motor	1400	3100

Note: The above wattages are estimates. Check nameplate wattages on all loads before connecting to generator.

UNPACKING

When unpacking, check to make sure that the item is intact and undamaged. If any parts are missing or broken, please call Harbor Freight Tools at 1-800-444-3353 as soon as possible.



REMOVE THESE BOLTS AND BRACKETS BEFORE USE!

There are two metal brackets that hold the generator in place during shipment to prevent damage. They must be removed before use. **See the photo above.**

CONTROLS

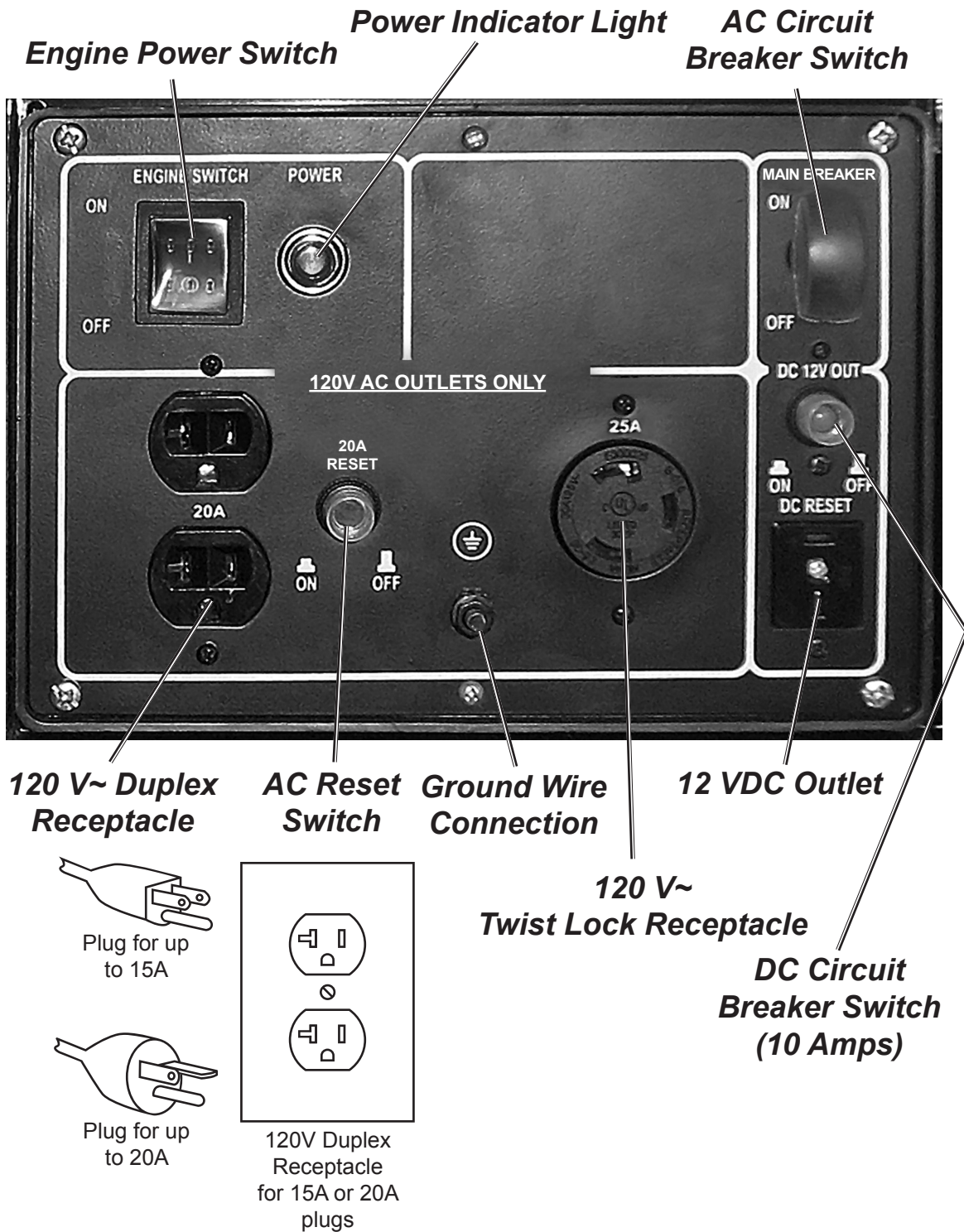

Engine Power Switch

Power Indicator Light

AC Circuit Breaker Switch

120 V~ Duplex Receptacle

AC Reset Switch

Ground Wire Connection

12 VDC Outlet

120 V~ Twist Lock Receptacle

DC Circuit Breaker Switch (10 Amps)

Note: Be sure to use the proper plug for the amps needed.

Figure 1

OPERATING INSTRUCTIONS



Read the **ENTIRE IMPORTANT SAFETY INFORMATION** section at the beginning of this manual including all text under subheadings therein before set up or use of this product.

⚠️ WARNING TO PREVENT SERIOUS INJURY:

Operate only with proper spark arrestor installed. Operation of this equipment may create sparks that can start fires around dry vegetation. A spark arrestor may be required. The operator should contact local fire agencies for laws or regulations relating to fire prevention requirements.

Starting the Engine



Inspect engine and equipment looking for damaged, loose, and missing parts before set up and starting. If any problems are found, do not use equipment until fixed properly.

Before starting, first familiarize yourself with proper shut down and emergency shut down procedures.

Checking and Filling Engine Oil

CAUTION! Your Warranty is VOID if the engine's crankcase is not properly filled with oil before each use. Before each use, check the oil level. Do not run the engine with low or no engine oil. Running the engine with no or

low engine oil WILL permanently damage the engine. **Check the oil level with the engine stopped and in a level position.**

1. Wipe dipstick exterior with a clean cloth. Remove the dipstick and wipe it off with a clean rag. Pour engine oil into the oil fill hole until the level of oil is even with the bottom edge of the oil fill hole (if you cannot see the oil through the oil fill hole, then the oil is too low and more oil must be added).
2. Reinsert the dipstick into the oil filler neck, but do not screw in; then remove it to check the oil level. The oil level should reach the upper limit (H) mark on the dipstick (bottom edge of the oil fill hole).
3. If the oil level is not to the upper limit mark (bottom edge of the oil fill hole), add the appropriate type of oil until the oil level reaches the upper limit mark.

THIS GENERATOR HAS AN AUTO-SHUTDOWN OIL SENSOR. IF ENGINE STOPS OR WILL NOT START, CHECK OIL LEVEL.

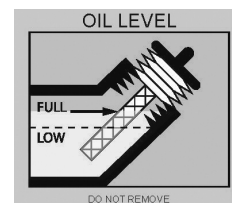

Engine Oil	SAE 10W-30 above 32°F SAE 5W-30 at 32°F or below
------------	---

4. Replace the Oil Dipstick.

The Oil Sensor will automatically shut down the engine before the oil level falls below the safe/low limit. To avoid nuisance tripping of the Oil Sensor and damage to property, check that the oil level is at the

bottom edge of the oil fill hole before each start-up.

CAUTION! DO NOT run the engine with low oil or no oil; the engine will be permanently damaged.

Checking and Filling Fuel

1. Check the fuel level. If the fuel level is more than 1" below the fill neck of the fuel tank, add more fuel.

Note: Do not overfill the fuel tank.



▲WARNING! TO PREVENT SERIOUS INJURY FROM FIRE:

- Fill the fuel tank in a well-ventilated area away from ignition sources. Do not smoke.
2. To fill the Fuel Tank, first wipe off the Fuel Tank Cap and the surrounding area.
 3. Unscrew, and remove the Fuel Tank Cap.
 4. Mix fuel stabilizer (not included) with 91 octane (or better) premium unleaded gasoline according to fuel stabilizer directions.

Note: Use only premium octane unleaded gasoline.

5. Fill the Fuel Tank to about 1 inch under the fill neck of the gasoline tank with the stabilized unleaded gasoline mixture.
6. Then replace the Fuel Tank Cap.

Start Procedure



Before starting the engine:

- a. **Inspect the equipment and engine.**

- b. **Fill the engine with the proper amount and type of fuel and oil.**
- c. **Read the Equipment Operation section that follows.**

1. Unplug loads from the Generator and make sure the AC Circuit Breaker Switch is in the OFF position before starting to prevent permanent generator damage.
2. Turn the engine fuel valve to its ON or OPEN position.
3. Turn the Engine Power Switch to its ON or RUN position.
4. Then, turn the engine choke lever to its "CHOKE" position. Set the choke lever in the "RUN" position when starting a warm engine.
5. Grasp the starter handle, and pull slowly until resistance is felt. While holding the handle, allow the starter rope to rewind. Then, pull the starter handle with a rapid, full arm stroke. Once again while holding the handle, allow the rope to rewind. Repeat as necessary, until the engine starts.
6. After the engine starts and warms up, slowly move the choke lever to its "RUN" position.

IMPORTANT: Allow the engine to run at no load until warm (1-5 minutes) to stabilize.

7. Move the AC Circuit Breaker Switch to its ON or RUN position.

Break-in Period

1. Breaking-in the engine will help to ensure proper equipment and engine operation, and will extend the engine's lifespan. The warranty is void if the engine is not broken in properly. The first 20 hours of operation is the break-in period.
2. During the first 3 hours of use:
 - Do not apply a heavy load to the equipment.
3. After the first 20 hours of use:
 - Change the engine oil.

Under normal operating conditions subsequent maintenance follows the schedule explained in the MAINTENANCE AND SERVICING section.

Equipment Operation

⚠ WARNING TO PREVENT SERIOUS INJURY

**AND DEATH:
DO NOT CONNECT
GENERATOR DIRECTLY TO
HOUSEHOLD WIRING.
A portable electric generator
that is connected to your
household wiring without a
proper cut off switch can
'back feed' into the power
lines connected to your home.
Power created by your
generator can injure or even
kill a utility lineman making
outage repairs many miles
away.
Only a certified electrician can
safely connect the generator
to your home's wiring.**

1. Make sure your generator is properly grounded to avoid electrical shocks. Connect a 10 gauge or larger insulated copper wire to the Ground Wire Connection on the Control Panel. Connect this wire to a suitable external ground, such as a copper stake in the ground.
2. Don't overload the generator. The total wattage used by the appliances should be less than the output rating of the generator. If you put too many appliances on the generator, it could seriously damage the appliances and electronics. Overloading the generator could also cause fires in the power cord. This generator is rated at 3050 / 3500 Watts.

NOTE: At start-up, appliances draw more power in a surge than they do during continuous operation. When figuring total wattage of all appliances connected to this generator, use the higher start-up amperage rating of each appliance.

3. Do not exceed the current limit specified for any one receptacle.
4. Move the AC Circuit Breaker Switch to the ON position.
5. Plug in your extension cord or appliance.
6. Be sure that all appliances are in good working order before connecting them to the generator. If an appliance begins to operate abnormally, becomes sluggish, or stops suddenly, turn off the AC Circuit Breaker and the generator Engine Power Switch immediately. Then disconnect the appliance and examine it for signs of malfunction.

Note: If an overloaded circuit causes the AC Circuit Breaker to switch off, reduce the electrical load on the circuit and wait a few minutes before resetting the circuit breaker.

7. The DC terminal may be used to operate 12 Volt DC portable appliances only.

CAUTION! Do not use this generator to charge 12VDC batteries. Directly charging a 12 Volt battery may cause the battery to overheat and possibly explode. CAUTION: Do not attempt to start an automobile engine with this generator. Voltage back feed from the alternator may damage the generator.

Note: The DC terminal may be used while the AC power is in use. An overloaded DC circuit will trip the DC circuit protector (push button comes out). If this happens, wait a few minutes before pushing in the circuit protector to resume operation.

8. **Disconnect all loads from the generator before shutting off.** To prevent accidents, turn off the engine and disconnect its spark plug wire after use. Wait for the engine to cool, clean external parts with clean cloth, then store the equipment out of children's reach according to the Storage instructions in this manual.

Control Panel Features

1. Engine Power Switch must be in ON position for engine to start and run. Move to OFF position to stop engine.
2. Power Indicator Light, when lit, shows that the generator is producing electrical energy.

3. AC Circuit Breaker Switch protects circuits when using AC power.
4. 120 V~ duplex outlet provides two grounded outlets for standard 110-120 V~ household appliances. The outlets are configured for both standard 15A plugs or 20A plugs - See Figure 1 "Controls".
5. 120 V~ twist lock receptacle provides a grounded outlet for one 120 Volt appliance, such as a water heater.
6. 12 VDC outlet provides a power source for 12 volt DC items, such as automotive accessories. 12 VDC Circuit Breaker Switch provides circuit protection for 12 VDC accessories.

TECHNICAL SPECIFICATIONS

Engine Type		4 Stroke, OHV
Bore x Stroke		70 x 54mm
Compression Ratio		8.5:1
Displacement		208cc
Fuel	Type	91+ octane premium unleaded gasoline
	Capacity	4 Gallons
Engine Oil	Type	SAE 10W-30 above 32° F SAE 5W-30 at 32° F or below
	Capacity	2/3 Quarts
Spark Plug	Compatible Types	NGK BP61S Bosch W6DC Champion N11YC
	Gap	0.024~0.031"
Valve Clearance	Intake	0.1mm
	Exhaust	0.15mm
Speed		3600 RPM

SERVICING

⚠ WARNING TO PREVENT SERIOUS INJURY FROM ACCIDENTAL STARTING:
Turn the Power Switch of the equipment to its "OFF" position, wait for the engine to cool, and disconnect the spark plug wire(s) before performing any inspection, maintenance, or cleaning procedures.

⚠ WARNING TO PREVENT SERIOUS INJURY FROM EQUIPMENT FAILURE:
Do not use damaged equipment. If abnormal noise, vibration, or excess smoking occurs, have the problem corrected before further use.

Maintenance Procedures



Many maintenance procedures, including those not detailed in this manual, will need to be performed by a qualified technician for safety. If you have any doubts about your ability to safely service the equipment or engine, have a qualified technician service the equipment instead.

Note: Warranty is void if proper maintenance and servicing procedures are not followed.

Engine Oil Change

⚠ CAUTION! Oil is very hot during operation and can cause burns. Wait for engine to cool before changing oil.

1. Place a drain pan (not included) underneath the crankcase's drain plug.
2. Remove the Drain Plug (1a) and, if possible, tilt the crankcase slightly to help drain the oil out. Recycle used oil.
3. If the Drain Plug Washer (2a) is damaged, replace with a new Washer.
4. Re-install the Drain Plug and tighten it in place.
5. Refill the oil to the proper level following the instructions under the Starting the Engine section.

Air Filter Element Maintenance

1. Wipe off the air cleaner cover.

2. The air cleaner cover is held in place by clamps. Remove the clamps and the cover.
 3. Remove the air filter element.
 4. **Cleaning:**
 - a. There are two foam filter elements. Wash them in warm water and mild liquid soap several times. Rinse. Squeeze out excess water and allow it to dry completely.
 - b. Soak the filter in lightweight oil briefly, then squeeze out the excess oil.
 5. Install the new filter or the cleaned filter. Secure the Air Cleaner Cover before use.
- Gasket-style: Finger-tighten until the gasket contacts the cylinder head, then about 1/2-2/3 turn more.
Non-gasket-style: Finger-tighten until the plug contacts the head, then about 1/16 turn more.
6. Apply dielectric spark plug boot protector (sold separately) to the end of the spark plug and reattach the wire securely.

Spark Plug Maintenance

1. Disconnect spark plug wire from end of plug. Clean out debris from around spark plug.
2. Using a spark plug wrench, remove the spark plug.
3. Inspect the spark plug:
If the electrode is oily, clean it using a clean, dry rag.
If the electrode has deposits on it, polish it using emery paper.
If the white insulator is cracked or chipped, the spark plug needs to be replaced.
4. When installing a new spark plug, adjust the plug's gap to the specification on the Technical specification chart. Do not pry against the electrode or the insulator, the spark plug can be damaged.
5. Install the new spark plug or the cleaned spark plug into the engine.

Cleaning, Maintenance, and Lubrication Schedule

Note: This maintenance schedule is intended solely as a general guide. If performance decreases or if equipment operates unusually, check systems immediately. The maintenance needs of each piece of equipment will differ depending on factors such as duty cycle, temperature, air quality, fuel quality, and other factors.

Note: These procedures are in addition to the regular checks and maintenance explained as part of the regular operation of the engine and equipment.

After Initial 20 Operation Hour Period:

- a. Change engine oil.

Every 25 Operation Hours Thereafter:

- a. Clean/replace air filter element.
- b. Inspect/clean spark plug.

Every 50 Operation Hours:

- a. Change engine oil.
- b. Replace fuel filter (if equipped).
- c. Check spark plug. Clean and re-gap as needed.

Every 100 Operation Hours:

- a. Replace spark plug.
- b. Replace air filter element.
- c. Clean fuel tank and fuel strainer.

Note: All maintenance procedures scheduled for 25, 50, and 100 operation hours should be performed at least yearly.

Every 300 Operation Hours:

- a. Clean fuel tank and carburetor.
- b. Clean carbon build-up from combustion chamber.
- c. Check oil tube condition and replace as needed.

Storage

1. Wait for engine to cool, then clean engine with clean cloth.
2. When the equipment is to remain idle for longer than 20 days, prepare the engine for storage as follows:
 - a. Change engine oil and empty fuel tank.
 - b. Either leave fuel tank empty or refill fuel tank with fresh unleaded gasoline mixed with a fuel stabilizer intended for long term engine storage (not included). After filling, run engine for about 5-10 minutes to circulate the treated gasoline through the carburetor. Wait for engine to cool before proceeding.
 - c. Clean out area around spark plug. Remove spark plug and pour one tablespoon of engine oil into cylinder through spark plug hole.
 - d. Reinstall spark plug, but leave spark plug wire disconnected.
 - e. Pull recoil starter to distribute oil in cylinder. Stop after one or two revolutions when you feel the piston start the compression stroke (when you start to feel resistance).
 - f. Disconnect battery cables (if equipped).
3. Apply a thin coat of rust preventive oil to all uncoated metal parts.

4. Cover and store in a dry, well-ventilated area out of reach of children.
5. Before starting the engine after storage, keep in mind that untreated gasoline will deteriorate quickly.
 - a. Place a container below the carburetor bowl and drain the fuel from the fuel tank and carburetor bowl.
 - b. Discard the drained fuel properly as per local ordinance.
 - c. Change to fresh fuel if untreated gasoline has been sitting for a month, if treated gasoline has been sitting beyond the fuel stabilizer's recommended time period, or if the engine does not start properly.

Engine Troubleshooting

Problem: Low power output. Engine bogs down or dies under load. Excess exhaust or unburned fuel in exhaust. See chart below:

Engine System	Possible Cause	Possible Solution
Ignition System	Incorrect Ignition Timing	Adjust Engine Advance Angle
Fuel Supply System	<ol style="list-style-type: none"> 1. Air in fuel line or fuel line clogged. 2. Main Jet not adjusted properly. 3. Metering Jet or Main Jet clogged. 4. Fuel Cock clogged. 5. Carbon Fouling in Combustion Chamber. 6. Clogged Air Filter. 7. Intake Manifold leaking. 	<ol style="list-style-type: none"> 1. Purge air or clear obstruction. 2. Readjust Main Jet. 3. Clean and Readjust. 4. Clean as needed. 5. Clean out Combustion Chamber. 6. Clean or replace Air Filter. 7. Repair or replace as needed.
Poor Compression	<ol style="list-style-type: none"> 1. Worn Piston, Piston Ring or Cylinder Wall. 2. Leaking Cylinder Head Gasket. 3. Worn Valves, Valve Seats, Stems or Valve Guides. 	<ol style="list-style-type: none"> 1. Check compression and wear tolerances, repair or replace as needed. 2. Check compression, replace as needed. 3. Check wear tolerances, repair or replace as needed.

Problem: Engine does not start or does not run smoothly. See chart below:

Symptom	Possible Cause	Possible Solution
Engine is Pinging	Excess wear of: <ul style="list-style-type: none"> • Piston, Cylinder Wall or Rings. • Piston Pin or Piston Pin Hole. • Connecting Rod Wrist Pin. • Crankshaft Roller Bearing. 	Check wear, replace as needed.
Abnormal Combustion or engine running hot or excess smoking.	<ol style="list-style-type: none"> 1. Combustion chamber carbon fouling. 2. Dirty or old gasoline or oil in gas. 	<ol style="list-style-type: none"> 1. Clean out Combustion chamber and spark plug. 2. Drain gas, clean out fuel filter and replace with fresh gas, minimum 91 octane premium unleaded gasoline.
Engine does not start.	<ol style="list-style-type: none"> 1. Engine Switch in OFF position. 2. Water in Carburetor Bowl. 3. Spark Plug gap not correct. 4. Incorrect Ignition Timing. 5. Damaged coil or ignition wires. 6. Low Oil level. 	<ol style="list-style-type: none"> 1. Move Switch to ON position. 2. Drain carburetor Bowl, clean Fuel Filter. 3. Clean and re-gap plug to 0.024" - 0.031". Replace plug if needed. 4. Check timing and adjust. 5. Check for damaged wires, test output. 6. Check oil level, top off as needed.

Engine not running Smoothly	<ol style="list-style-type: none"> 1. Poor Fuel quality. 2. Incorrect choke setting. 3. Incorrect Timing. 	<ol style="list-style-type: none"> 1. Replace fuel with 91+ octane premium unleaded gasoline. 2. Adjust the choke. 3. Have the timing checked by a qualified technician.
-----------------------------	--	---

Problem: Engine stops suddenly while running. See chart below:

Engine System	Possible Cause	Possible Solution
Fuel Supply System	<ol style="list-style-type: none"> 1. Fuel is used up. 2. Fuel Filter is clogged. 3. Carburetor Float is leaking. 4. Needle Valve sticks. 	<ol style="list-style-type: none"> 1. Check fuel level and refill as needed. 2. Clean Fuel Filter. 3. Replace if needed. 4. Clean and readjust.
Ignition System	<ol style="list-style-type: none"> 1. Engine Switch is in OFF position. 2. Spark Plug tip is burned through or carbon fouled. 3. Spark Plug Wire is disconnected. 4. Spark Plug wire is shorting against engine body or frame. 5. Ignition Coil is shorted or damaged. 	<ol style="list-style-type: none"> 1. Move Switch to ON position. 2. Clean or replace spark plug. Reset gap to 0.024 - 0.031". 3. Check connections at both ends. 4. Check condition of spark plug wire, replace as needed. 5. Check coil continuity and output.
Mechanical problem	<ol style="list-style-type: none"> 1. Engine Piston, Piston Rod, Valve or Crankshaft may be damaged. 2. Generator Shaft may be seized. 	<ol style="list-style-type: none"> 1. Have serviced by a qualified technician. 2. Disconnect engine and attempt to rotate generator shaft by hand. Repair or replace as needed.

Problem: Engine runs excessively hot. See chart below:

Problem	Possible Cause	Possible Solution
Engine runs excessively hot	<ol style="list-style-type: none"> 1. Improper Ignition Timing. 2. Exhaust manifold, muffler or exhaust pipe damaged or clogged. 3. Intake Manifold leaking. 4. Dirty or clogged Cylinder Cooling Fins. 5. Cooling Fan loose or damaged. 6. Bent Piston Rod 7. Worn Piston, Piston Ring or Cylinder Wall. 8. Improper engine speed. 9. Worn Crankshaft Main Bearing. 	<ol style="list-style-type: none"> 1. Check and reset Ignition Timing. 2. Check condition of exhaust system, repair as needed. 3. Check condition of intake manifold and gasket. Repair as needed. 4. Clean Cylinder Wall Cooling Fins. 5. Check condition of cooling fan. Repair or replace as needed. 6. Replace Piston Rod. 7. Check clearances, replace as needed. 8. Engine speed is self-regulating. Be sure choke is fully open. Reduce electrical load on generator. 9. Check for wear. Replace as needed.

Equipment Troubleshooting		
Problem	Possible Causes	Probable Solutions
Engine Will Not Start	<ol style="list-style-type: none"> 1. No fuel in tank. 2. Engine Switch in OFF position. 3. Fuel Valve turned OFF. 4. Engine Oil level low. 5. No spark at spark plug. 6. No fuel reaching carburetor. 	<ol style="list-style-type: none"> 1. Refill the fuel tank. 2. Move the Switch to the ON position. 3. Turn the fuel valve ON. 4. Top off oil level. 5. Check that the spark plug wire is not loose or disconnected. Clean and re-gap spark plug. Replace if necessary. 6. Clean fuel filter cup. Check fuel line for leaks or obstructions.
Engine misses, is hard to start or runs poorly	<ol style="list-style-type: none"> 1. Fuel filter dirty. 2. Air cleaner dirty. 3. Spark plug dirty or wrong gap. 	<ol style="list-style-type: none"> 1. Check and clean the fuel filter. 2. Check and clean the air filter. 3. Check, clean and re-gap spark plug.
Power Light does not come on	<ol style="list-style-type: none"> 1. Engine is running poorly. 2. Ground wire is not connected. 3. Generator is not functioning. 	<ol style="list-style-type: none"> 1. Improve engine performance. 2. Connect ground wire. 3. Take generator to qualified service technician.
No or not enough power at the AC outlets.	<ol style="list-style-type: none"> 1. AC Breaker switch in the OFF position. 2. AC circuits overloaded. 	<ol style="list-style-type: none"> 1. Reset the Breaker Switch to the ON position. 2. Disconnect some appliances to reduce the load.
No power at the 12 VDC outlet.	DC Breaker Switch open.	Disconnect the 12 Volt appliance, then press the 12 VDC breaker switch IN. Reconnect the 12 V accessory.



Follow all safety precautions whenever diagnosing or servicing the equipment or engine. Consult a qualified service technician for any repairs beyond your training or ability.

PLEASE READ THE FOLLOWING CAREFULLY

THE MANUFACTURER AND/OR DISTRIBUTOR HAS PROVIDED THE PARTS LIST AND ASSEMBLY DIAGRAM IN THIS MANUAL AS A REFERENCE TOOL ONLY. NEITHER THE MANUFACTURER OR DISTRIBUTOR MAKES ANY REPRESENTATION OR WARRANTY OF ANY KIND TO THE BUYER THAT HE OR SHE IS QUALIFIED TO MAKE ANY REPAIRS TO THE PRODUCT, OR THAT HE OR SHE IS QUALIFIED TO REPLACE ANY PARTS OF THE PRODUCT. IN FACT, THE MANUFACTURER AND/OR DISTRIBUTOR EXPRESSLY STATES THAT ALL REPAIRS AND PARTS REPLACEMENTS SHOULD BE UNDERTAKEN BY CERTIFIED AND LICENSED TECHNICIANS, AND NOT BY THE BUYER. THE BUYER ASSUMES ALL RISK AND LIABILITY ARISING OUT OF HIS OR HER REPAIRS TO THE ORIGINAL PRODUCT OR REPLACEMENT PARTS THERETO, OR ARISING OUT OF HIS OR HER INSTALLATION OF REPLACEMENT PARTS THERETO.

Main Parts List

Part	Description	Qty
1	Gasoline Engine, UP170,7.0HP	1
2	Front Cover	1
3	Rotor assy	1
4	Stator assy	1
5	Protection board	1
6	Rear cover	1
7	White grounding wire	1
8	Connection pole	1
9	Carbon Brush	1
10	Rear cover	1
11	3kw Automatic Voltage Regulator	1
12	Shock Absorber	4
13	Muffler guard	1
14	Muffler assy	1
15	Pulsed Valve	1
16	Muffler Gasket	1
17	Exhaust Gasket	1
18	Fuel Tank (CARB Standard 278C blue)	1
19	Strainer	1
20	Fuel Tank Cap Assembly	1
21	Fuel Marker	1
22	Fuel Tank Connector	1
23	Washer ϕ 10.5	4
24	Shock Absorber for fuel tank	4
25	Clamp ϕ 7	1
26	Fuel Pipe ϕ 4.5	1
27	Clamp ϕ 8	1
28	Fuel Tank Cock Assembly	1
29	Fuel Pipe ϕ 7.5*300mm	1
30	Clamp ϕ 13	4
31	Fuel Pipe ϕ 7.5*380mm	1
32	Carbon Box	1
33	Frame assy	1
34	Control panel assy	1
35	Shock Absorber	4
36	Bracket	2
37	Grounding Wire (12cm) ϕ 6+ ϕ 6	1
38	Muffler guard 1	1
39	Muffler guard 2	1
40	Flange Screw M8X25	4
41	Flange Screw M8	4
42	Flange Screw M6X45	2
43	Spring washer 6	2
44	Plate washer 6	2
45	Plate washer 8	4
46	Spring washer 8	4

Part	Description	Qty
47	Flange Screw M8X25	4
48	Washer 8	1
49	Spring washer 8	1
50	Flange Screw 5/16-210, 24UNC	1
51	Flange Screw M6X130	4
52	Spring washer 6	4
53	Toothed Washer 5	1
54	Plate washer 5	1
55	Spring washer 5	1
56	Flange Screw M5X16	1
57	Full screw bolt M5X20	2
58	Flange nut M5	4
59	Plate washer 5	4
60	Spring washer 5	2
61	Flange Screw M5X16	2
62	Flange Screw M5X16	1
63	Flange Screw M5X12	2
64	Flange Screw M5X16	2
65	Flange Screw M8	8
66	Flange Screw M8	2
67	Spring washer 8	2
68	Plate washer 8	2
69	Nut M6X20	2
70	Spring washer 6	2
71	Flange Screw M8X35	1
72	Flange Screw M8	1
73	Flange Screw M6X12	2
74	Nut M6X14	2
75	Flange Screw M8X20	4
76	Washer 8	4
77	Flange nut M8	4
78	Flange Screw M6X12	6
79	Toothed Washer 5	1
80	Plate washer 5	1
81	Spring washer 5	1
82	Flange Screw M5X16	1
83	Flange nut M6	1
84	Toothed Washer 5	1
85	Plate washer 6	1
86	Spring washer 6	1
87	Flange Screw M6X12	1
88	Flange nut M6	4
89	Flange nut M8	4
90	Flange Screw M8X25	2
91	Flange nut M6	4
92	Nut M6X12	4

Main Assembly Diagram

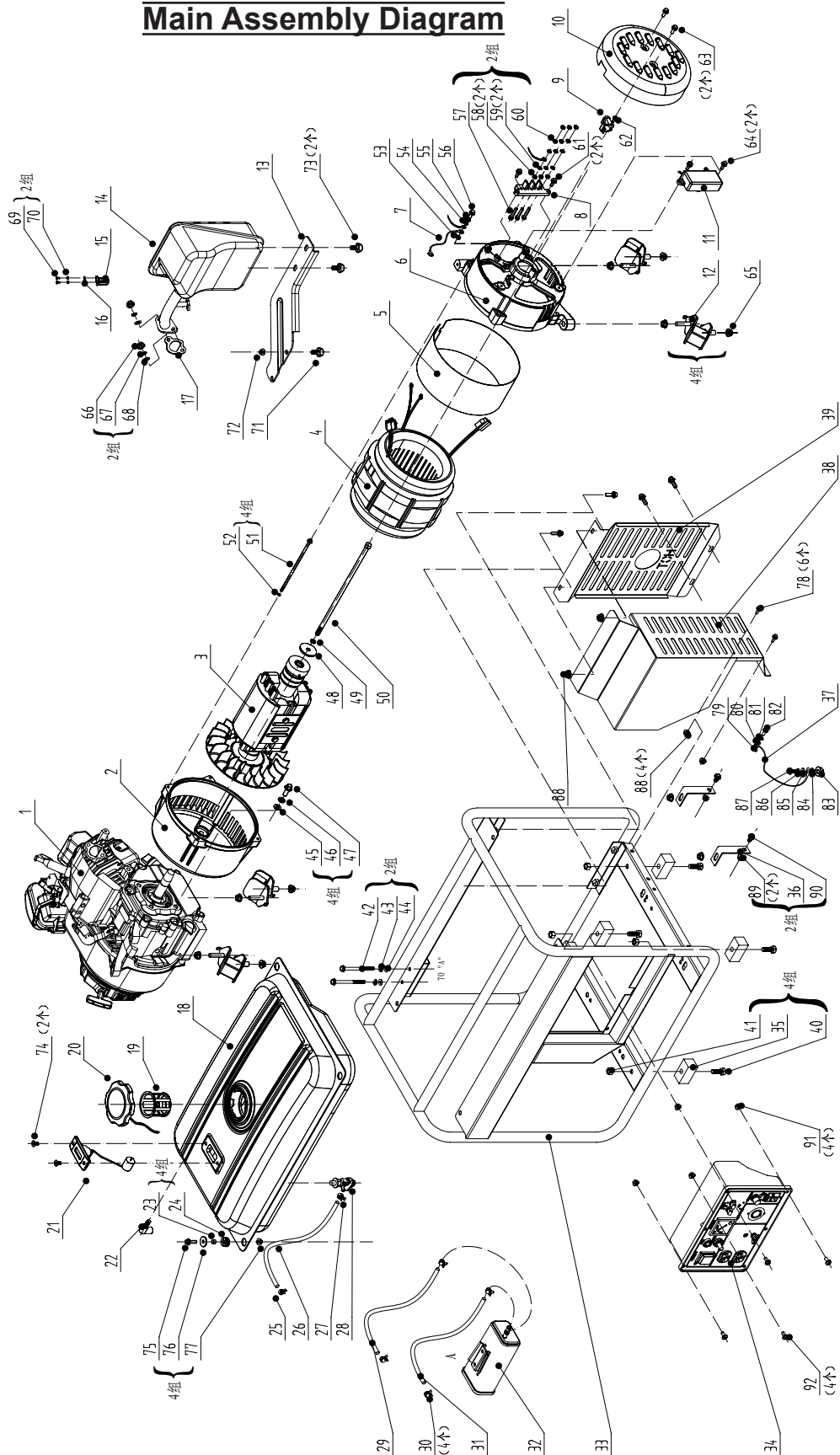

Parts List and Diagram A - Crankcase Assembly

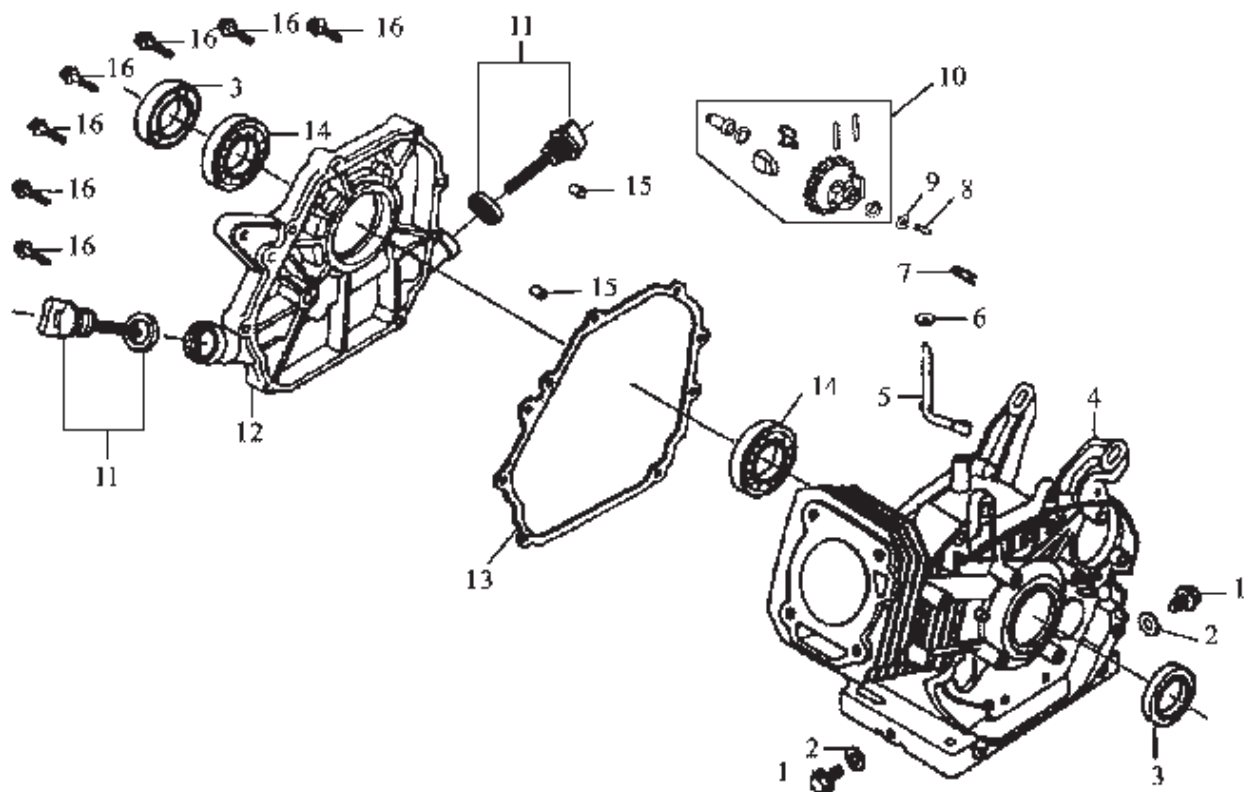

NOTE: All part numbers listed on the following pages have a letter suffix. For example, the Crankcase Cover shown in the above diagram is part # 12a. Whenever referring to engine sub-assembly parts, be sure to include the complete part number including the letter suffix.

Part #	Description	Qty
1a	Drain Plug	2
2a	Drain Plug Washer	2
3a	Crankshaft Oil Seal	2
4a	Crankcase	1
5a	Regulating Sway Bar	1
6a	Washer	1
7a	Split Pin	1
8a	Regulating Shaft	1

Part #	Description	Qty
9a	Snap Ring	1
10a	Driven Gear Assembly	1
11a	Dipstick with Seal	2
12a	Crankcase Cover	1
13a	Crankcase Gasket	1
14a	Bearing 6205	2
15a	Set Pin m 8 x 14	2
16a	Bolt m8 x 33.5	6

NOTE: Not all engine sub-assembly components shown on the following pages are available as separate replacement parts. They may be shown for informational purposes only.

Parts List and Diagram B - Cylinder Head Assembly

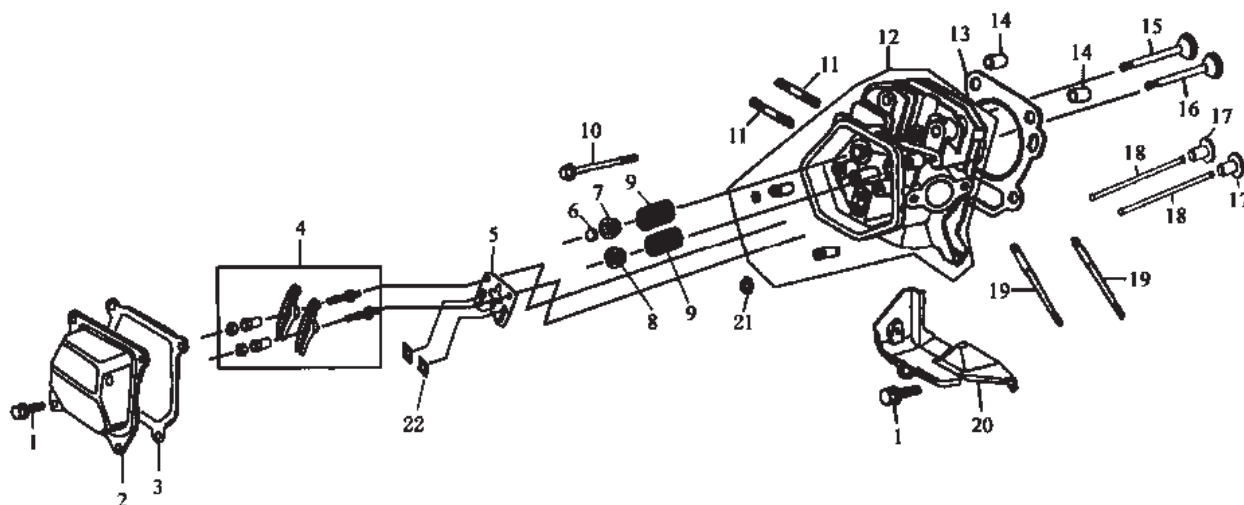

Part #	Description	Qty
1b	Bolt m 6 x 12	6
2b	Cylinder Head Cover	1
3b	Cylinder Head Cover Gasket	1
4b	Valve Rocker Assembly	1
5b	Push Guide	1
6b	Cap	1
7b	Exhaust Spring Seat	1
8b	Intake Spring Seat	1
9b	Valve Spring	2
10b	Bolt m 8 x 60	4
11b	Stud AM 8 x 34	2
12b	Cylinder Head Assembly	1

Part #	Description	Qty
13b	Cylinder Head Gasket	1
14b	Set Pin	2
15b	Exhaust Valve	1
16b	Intake Valve	1
17b	Tappet	2
18b	Pusher	2
19b	Stud AM 6 x 112	2
20b	Lead Wind Cover	1
21b	Oil Pipe Seal	1
22b	Clip	2

Parts List and Diagram C - Crankshaft, Piston, Connecting Rod, Camshaft and Flywheel Assemblies

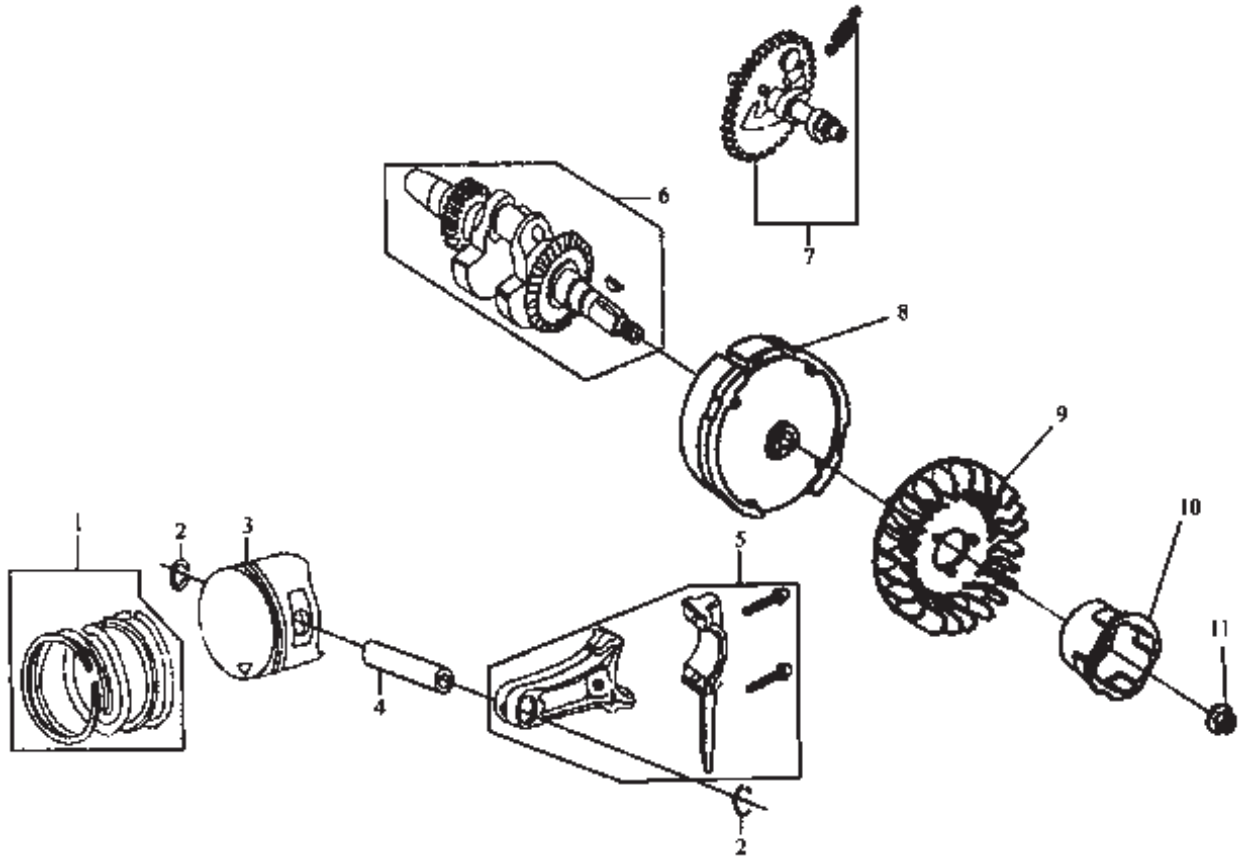

Part #	Description	Qty
1c	Piston Ring Set	1
2c	Piston Ring Circlip	2
3c	Piston	1
4c	Piston Pin	1
5c	Connecting Rod Assembly	1
6c	Crankshaft Assembly	1

Part #	Description	Qty
7c	Camshaft Assembly	1
8c	Flywheel	1
9c	Flywheel Fan	1
10c	Starting Flange	1
11c	Nut m 14 x 1.5	1

Parts List and Diagram D - Recoil Starter and Ignition Coil Assembly

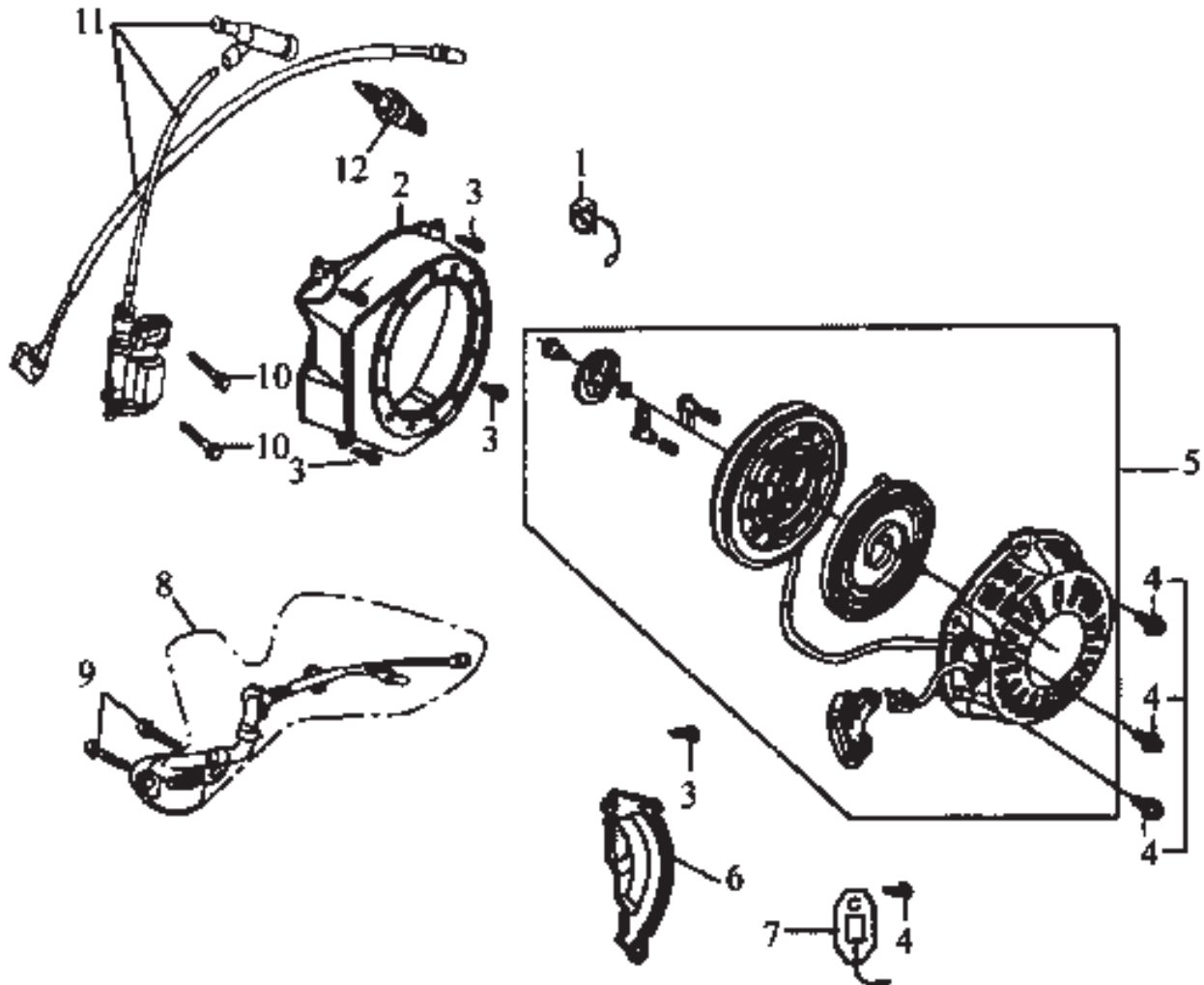

Part #	Description	Qty
1d	Engine Switch	1
2d	Fan Hood	2
3d	Bolt m 6 x 12	5
4d	Bolt m 6 x 8	4
5d	Recoil Starter Assembly	1
6d	Complete Shroud	1

Part #	Description	Qty
7d	Diode	1
8d	Oil Sensor	1
9d	Bolt m 6 x 14	2
10d	Bolt m 6 x 22	2
11d	Ignition Coil Assembly	1
12d	Spark Plug F6TC	1

Parts List and Diagram E - Air Cleaner and Muffler Assembly

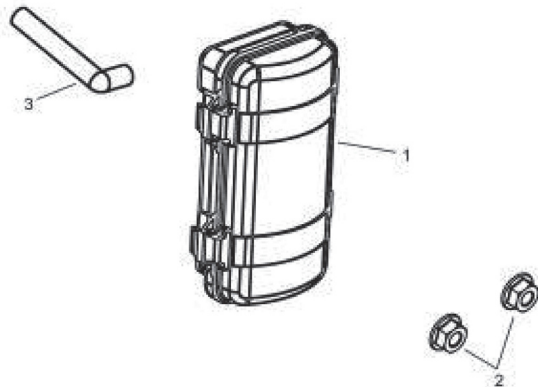

Part #	Description	Qty
1e	Air Cleaner Assembly	1
2e	Nut m6	2
3e	Air Duct	1

Parts List and Diagram F - Fuel Supply System

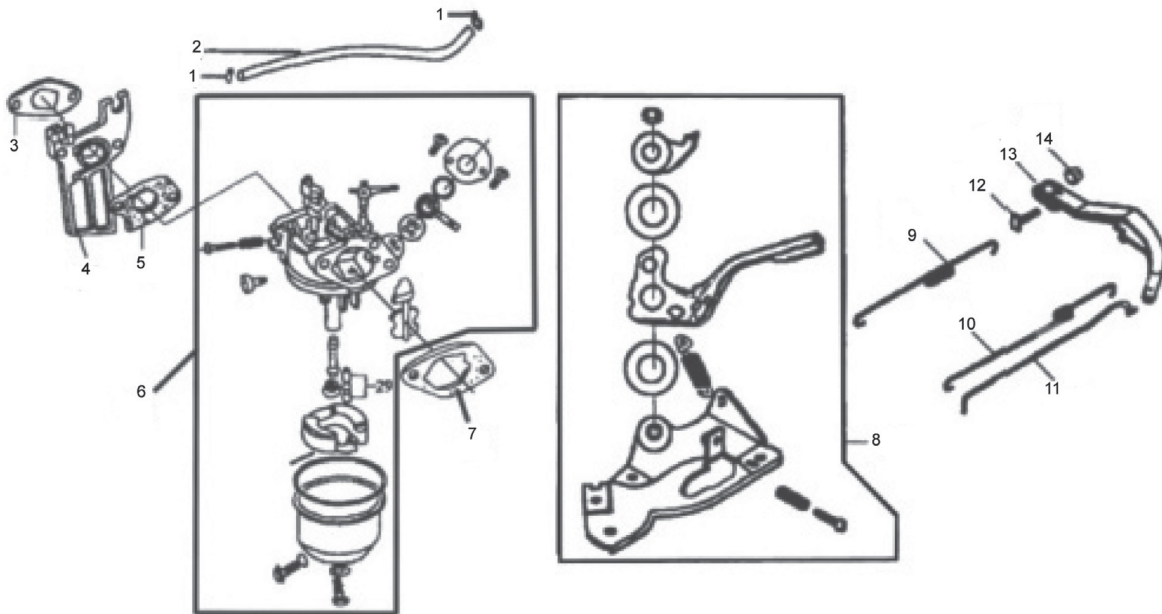

Part	Description	Qty
1f	Pipe Clamp	2
2f	Fuel Pipe m 4.5 x 170	1
3f	Intake Gasket	1
4f	Connecting Block	1
5f	Carburetor Gasket	1
6f	Carburetor Assembly	1
7f	Air Cleaner Gasket	1

Part	Description	Qty
8f	Regulator Assembly	1
9f	Back Spring	1
10f	Regulating Spring	1
11f	Pulling Rod	1
12f	Lock Bolt	1
13f	Regulating Spring	1
14f	Nut M6	1

Parts List and Diagram G - Starter and Generator Assembly

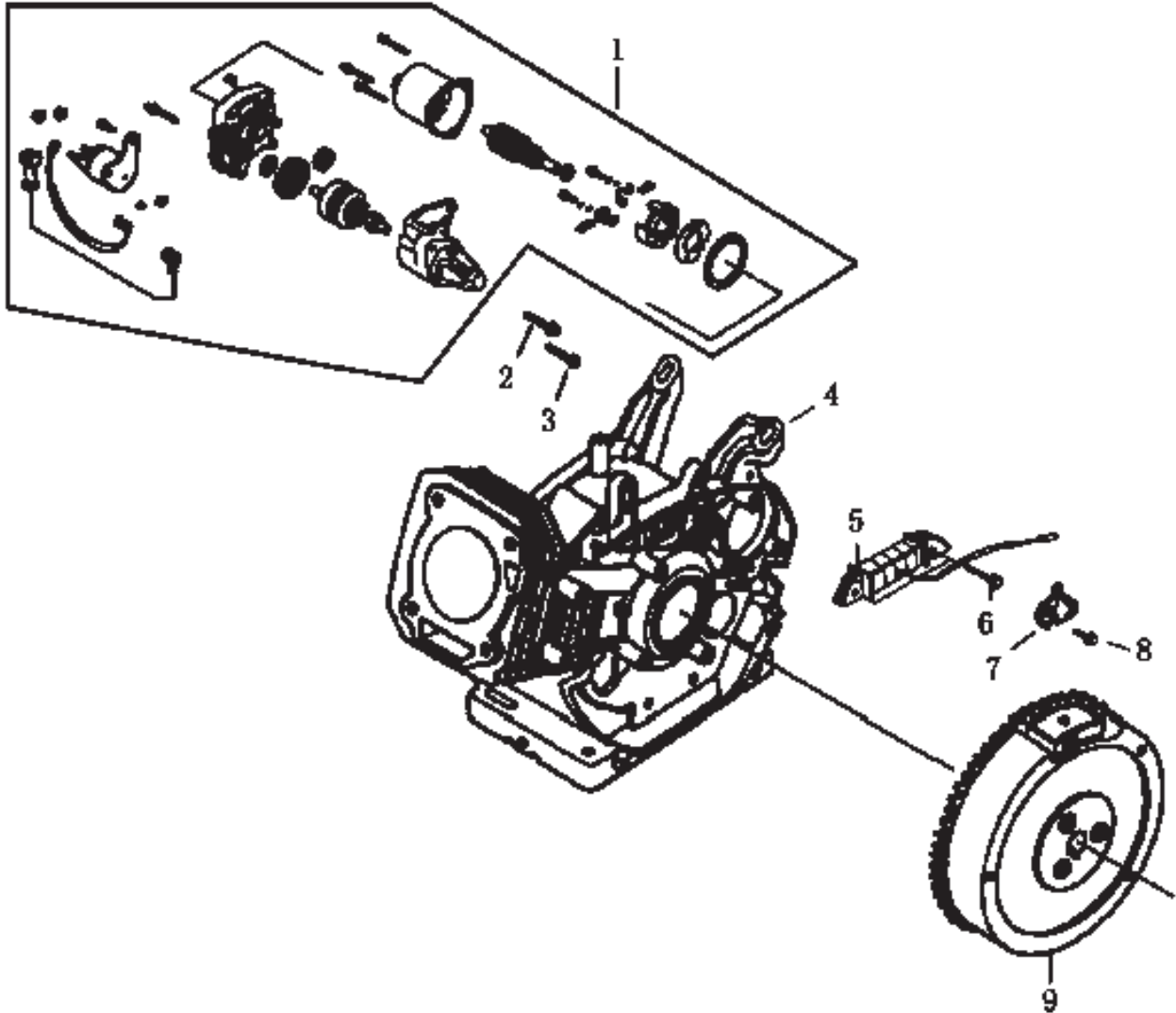

Part #	Description	Qty
1g	Starting Motor Assembly	1
2g	Bolt m6 x 28	1
3g	Bolt m6 x 32	1
4g	Crankcase	1
5g	Charge Coil	1

Part #	Description	Qty
6g	Bolt m6 x 35	2
7g	Clamp Cord	1
8g	Bolt m6 x 12	2
9g	Flywheel	1

Record Product's Serial Number Here: _____

Note: If product has no serial number, record month and year of purchase instead.

Note: Some parts are listed and shown for illustration purposes only, and are not available individually as replacement parts.

Wiring Diagram

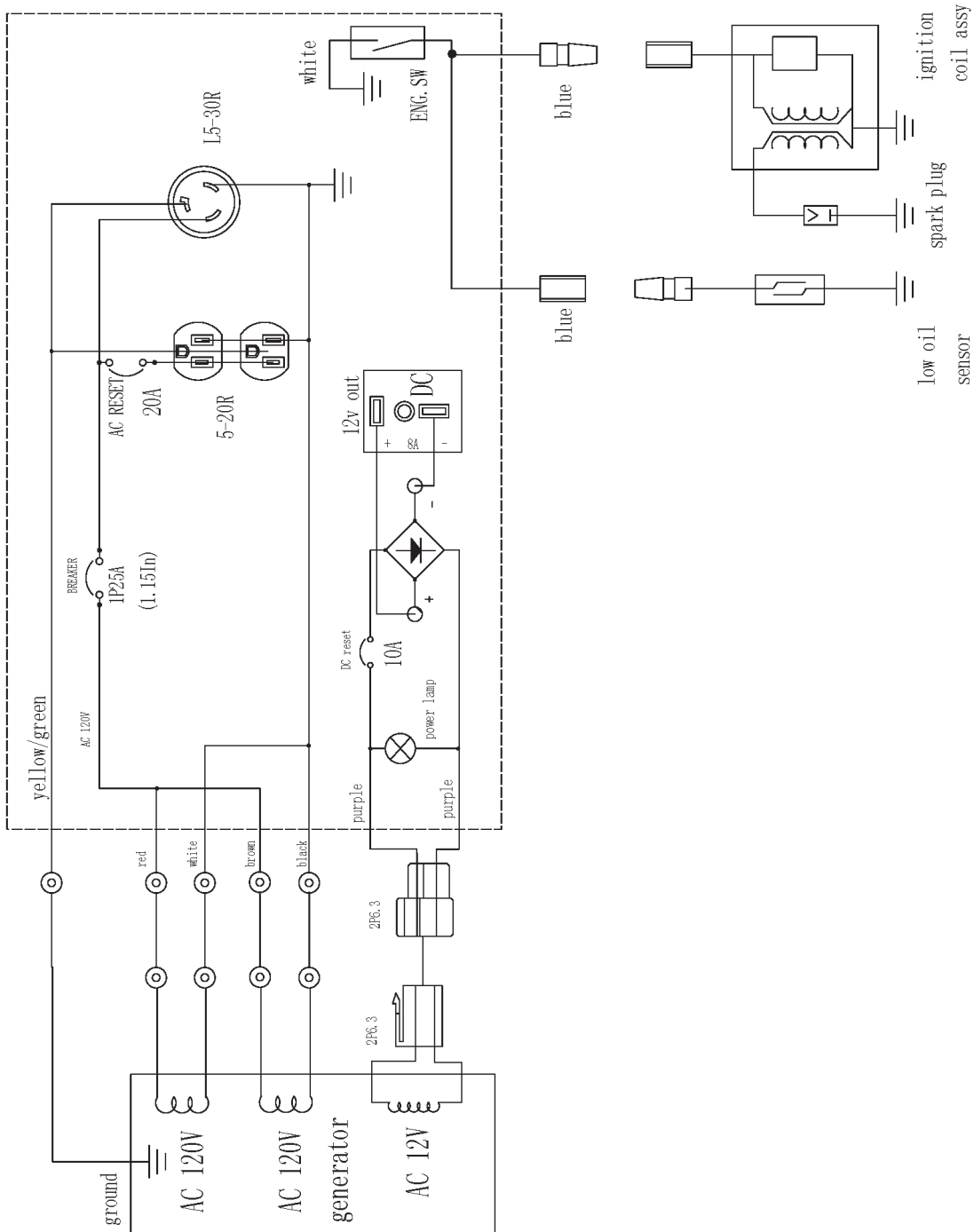

LIMITED 1 YEAR / 90 DAY WARRANTY

Harbor Freight Tools Co. makes every effort to assure that its products meet high quality and durability standards, and warrants to the original purchaser that for a period of ninety days from date of purchase that the engine/motor, the belts (if so equipped), and the blades (if so equipped) are free of defects in materials and workmanship. Harbor Freight Tools also warrants to the original purchaser, for a period of one year from date of purchase, that all other parts and components of the product are free from defects in materials and workmanship (90 days if used by a professional contractor or if used as rental equipment). This warranty does not apply to damage due directly or indirectly, to misuse, abuse, negligence or accidents, repairs or alterations outside our facilities, normal wear and tear, or to lack of maintenance. We shall in no event be liable for death, injuries to persons or property, or for incidental, contingent, special or consequential damages arising from the use of our product. Some states do not allow the exclusion or limitation of incidental or consequential damages, so the above limitation of exclusion may not apply to you. **THIS WARRANTY IS EXPRESSLY IN LIEU OF ALL OTHER WARRANTIES, EXPRESS OR IMPLIED, INCLUDING THE WARRANTIES OF MERCHANTABILITY AND FITNESS.**

To take advantage of this warranty, the product or part must be returned to us with transportation charges prepaid. Proof of purchase date and an explanation of the complaint must accompany the merchandise. If our inspection verifies the defect, we will either repair or replace

the product at our election or we may elect to refund the purchase price if we cannot readily and quickly provide you with a replacement. We will return repaired products at our expense, but if we determine there is no defect, or that the defect resulted from causes not within the scope of our warranty, then you must bear the cost of returning the product.

This warranty gives you specific legal rights and you may also have other rights which vary from state to state.

**3491 Mission Oaks Blvd. • PO Box
6009 • Camarillo, CA 93011 • (800)
444-3353**

EMISSION CONTROL SYSTEM WARRANTY

California and United States Emission Control Defects Warranty Statement

The California Air Resources Board (herein CARB), the United States Environmental Protection Agency (herein EPA), and Harbor Freight Tools (herein HFT) are pleased to explain the emission control system warranty on your 1995 and later Small Off-Road Engine (herein engine). In California, the engine must be designed, built and equipped to meet the State's stringent anti-smog standards. Elsewhere within the United States, new off-road, spark-ignition engines certified for model year 1997 and later, must meet similar standards set forth by the EPA. HFT must warrant the emission control system on your engine for the periods of time described below, provided there has been no abuse, neglect or improper maintenance of your engine.

Your emission control system may include parts such as the carburetor or fuel-injection system, and the ignition system. Also included may be hoses, belts, connectors and other emission-related assemblies.

Where a warrantable condition exists, HFT will repair your engine at no cost to you including diagnosis, parts and labor.

Manufacturer's Warranty Coverage

The 1995 and later engines are warranted for two (2) years. If any emission-related part on your engine is defective, the part will be repaired or replaced by HFT.

Harbor Freight Tools Emission Control Defects Warranty Coverage

Engines are warranted for a period of two (2) years relative to emission control parts defects, subject to the provisions set forth below. If any emission related part on your engine is defective, the part will be repaired or replaced by HFT.

Owner's Warranty Responsibilities

- As the engine owner, you are responsible for the performance of the required maintenance listed in your Owner's Manual. HFT recommends that you retain all receipts covering maintenance on your engine, but HFT cannot deny warranty solely for the lack of receipts or for your failure to ensure the performance of all scheduled maintenance.
- As the engine owner, you should, however, be aware that HFT may deny you warranty coverage if your engine or a part has failed due to abuse, neglect, improper maintenance, or unapproved modifications.
- You are responsible for shipping your engine to a HFT warranty station as soon as a problem exists. Contact the HFT Customer Service department at the number below to make shipping arrangements. The warranty repairs should be completed in a reasonable amount of time, not to exceed 30 days.

If you have any questions regarding your warranty rights and responsibilities, you should contact the Harbor Freight Tools Customer Service Department at 1-800-444-3353.

Harbor Freight Tools Emission Control Defects Warranty Provisions

1. Length of Coverage

HFT warrants to a first retail purchaser and each subsequent purchaser that the engine is free from defects in materials and workmanship that cause the failure of warranted parts for a period of two (2) years after the date of delivery to the first retail purchaser.

2. No Charge Repair or Replacement

Repair or replacement of any warranted part will be performed at no charge to the owner if the work is performed through a warranty station authorized by HFT. For emissions warranty service, contact the HFT Customer Service Department at 1-800-444-3353.

3. Consequential Damages Coverage

Coverage under this warranty shall also extend to the failure of any engine components caused by the failure of any warranted part while it is still covered under this warranty.

4. Coverage Exclusions

Warranty claims shall be filed in accordance with the provisions of the HFT warranty policy explained in the box at the top of the previous page. HFT shall not be liable for any loss of use of the engine, for any alternative usage, for any damage to goods, loss of time, or inconvenience. Warranty coverage shall also be excluded for any part which fails, malfunctions, or is damaged due to failure to follow the maintenance and operating instructions set forth in the Owner's Manual including, but not limited to:

- a) Use of parts which are not authorized by HFT
- b) Improper installation, adjustment or repair of the engine or of any warranted part unless performed by an authorized warranty center
- c) Failure to follow recommendations on fuel use contained in the Owner's Manual
- d) Improper or inadequate maintenance of any warranted parts
- e) Repairs performed outside of the authorized warranty service dealers
- f) Alterations by changing, adding to or removing parts from the engine.

5. Service and Maintenance

Component parts which are not scheduled for replacement as required maintenance or are scheduled only for regular inspection to the effect of "repair or replace as necessary" are warranted for the warranty period. Any warranted part which is scheduled for replacement as required maintenance is warranted for the period of time up to the first scheduled replacement point for that part. Any replacement part, provided it is equivalent in durability and performance, may be used in performance of maintenance or repairs. The owner is responsible for commissioning a qualified technician/mechanic to perform all required maintenance, as outlined in the Inspection, Cleaning, and Maintenance section in this manual.

6. Warranted Parts

- 1) Fuel Metering System
 - i) Carburetor and its internal parts.
 - ii) Fuel pump (if so equipped).
 - iii) Cold start enrichment system.
- 2) Air Induction System
 - i) Intake pipe/manifold.
 - ii) Air cleaner.
- 3) Ignition System
 - i) Spark plug.
 - ii) Magneto ignition system.
- 4) Catalyst System (if so equipped)
 - i) Exhaust pipe stud.
 - ii) Muffler.
 - iii) Catalytic converter (if so equipped).
- 5) Miscellaneous Items Used in Above Systems
 - i) Vacuum, temperature and time sensitive valves and switches.
 - ii) Hoses, belts, connectors, and assemblies.

Free Manuals Download Website

<http://myh66.com>

<http://usermanuals.us>

<http://www.somanuals.com>

<http://www.4manuals.cc>

<http://www.manual-lib.com>

<http://www.404manual.com>

<http://www.luxmanual.com>

<http://aubethermostatmanual.com>

Golf course search by state

<http://golfingnear.com>

Email search by domain

<http://emailbydomain.com>

Auto manuals search

<http://auto.somanuals.com>

TV manuals search

<http://tv.somanuals.com>