

SPI EXPANSION

IMPORTANT: THE 1st KT-MOD-INP16 SPI IN (TB1) MUST BE CONNECTED TO THE KT-400 SPI PORT BEFORE STARTING A GROUP OF OUTPUT MODULES (KT-MOD-REL8 and KT-MOD-OUT16) THROUGH THE SPI EXPANSION CONNECTOR (SPI EXP)

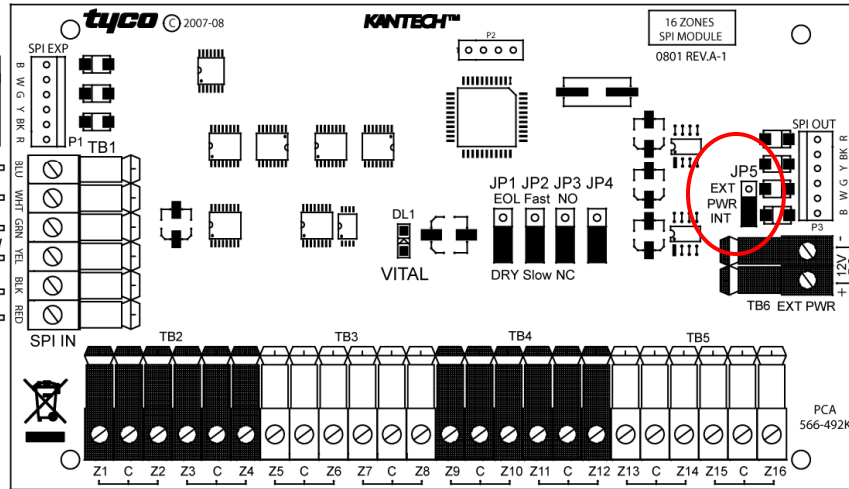

SPI OUT CONNECTION TO INPUT MODULES KT-MOD-INP16 ONLY

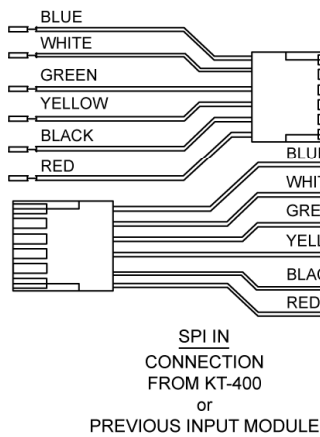
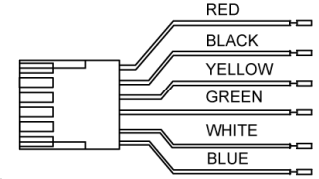

REGULATED POWER SUPPLY 12 VDC, 2 Amps

1. Introduction

The **KT-MOD-INP16** is an input module that adds up to 16 zones to the **KT-400** controller. The module supports daisy chaining; you can interconnect up to 15 **KT-MOD-INP16** modules for a total of 240 external inputs per **KT-400**. Adding the 16 onboard inputs of the **KT-400** gives a total of 256 inputs per **KT-400**. Combining input and output expansion modules gives the flexibility to connect up to 256 inputs and 256 outputs.

Note 1: The **KT-400** SPI port maximum current draw, when the 12V AUX terminals are not used, is 500 mA.

Note 2: External power supply (12 VDC, 2 Amps) is required when the total current draw exceeds 500mA on the SPI Port.

2. Specifications

- Maximum Current Draw: up to 40 mA per module
- Supports single end-of-line (5600 ohm resistors) and no end-of-line (DRY) zone loops
- Supports Normally Closed (NC) and Normally Open (NO) contacts
- The C (Common) terminal is +12 VDC
- Input change with a debouncing of 500 ms (Slow) or 150 ms (Fast)
- Reports one condition per input: SECURE or ALARM
- Can be used for contact or elevator input
- Cannot be connected to output modules **KT-MOD-REL8** and **KT-MOD-OUT16** through SPI OUT, only through its SPI EXP expansion port

3. Installing the KT-MOD-INP16 Module

3.1. Unpacking

The **KT-MOD-INP16** package includes the following parts:

- One (1) **KT-MOD-INP16** module, 14 cm x 8 cm (5.7 in x 3.25 in)
- One (1) SPI cable with 1 SPI connector, 41 cm (16 in)
- Four (4) plastic standoffs
- Two (2) installation sheets, English and French

VITAL LED

1 flash/sec	Communicating with KT-400	
Continuous quick flashing	Loss communication for more than 5 secs, Fail-soft state	

3.2. Mounting

The **KT-MOD-INP16** can be installed inside a compatible cabinet (**KT-MOD-CAB** or **KT-400**) or mounted in a dry and secure location at less than 1 m (3 ft) from the **KT-400**.

1. Press the four (4) plastic standoffs through the mounting holes of the cabinet,
2. Secure the cabinet to the wall in the desired location. Use appropriate wall anchors when securing the cabinet to drywall, plaster, concrete, brick or other surfaces.
3. Press the module into the plastic standoffs to secure the module to the cabinet.

3.3. SPI Wiring

Perform the following steps to complete wiring:

Note 1: Before beginning to wire the unit, ensure that all power (AC transformer and battery) is disconnected from the **KT-400**.

Note 2: If you are combining input and output modules through the SPI EXP expansion port of the **KT-MOD-INP16**, the input module must be the 1st module connected to the **KT-400** SPI Port.

1. Connect the 6-pin SPI connector to the **KT-400** SPI port or to the SPI OUT of the previous **KT-MOD-INP16** module.
 2. Connect the six SPI wires (blue (BLU), white (WHT), green (GRN), yellow (YEL), black (BLK) and red (RED)) to the SPI IN (TB1) terminals.
 3. You can use the SPI EXP of the 1st **KT-MOD-INP16** to start a group of output modules (**KT-MOD-REL8** and **KT-MOD-OUT16** only).
 4. Connect the 6-pin SPI connector from the SPI OUT to the next **KT-MOD-INP16** module.
 5. Complete all zone wiring to the zone input terminals (Z1-Z16).
- 3.4. Check the power jumper **JP5** position. Put it on **EXT** if you need external power or **INT** if no external power is required.

CONFIGURATIONS FOR THE SIXTEEN ZONE INPUTS WITH JUMPERS

JP1	JP2	JP3	DESCRIPTION
EOL		NO	Normally Open contact with single End of Line resistor
EOL		NC	Normally Close contact with single End of Line resistor
DRY		NO	Normally Open contact without End of Line resistor
DRY		NC	Normally Close contact without End of Line resistor
	FAST		150 ms input debounce time
	SLOW		500 ms input debounce time

4. Configurations with Jumpers

There are 3 jumpers available to configure the KT-MOD-INP16. The jumper settings apply to **ALL** 16 inputs at the same time.

Note: Jumper JP4 is for future use.

DRY (without end-of-line resistor): In a simple NC dry contact configuration, the **secure** state is given when a short is detected. The voltage becomes lower than the **Level 1** threshold value (1.1V).

The **alarm** state is given when the input is open. The voltage becomes higher than the **Level 2** threshold value (3.75V). If the alarm switch is programmed as NO device, the **alarm** state will be given when the input is shorted.

EOL (with end-of-line resistor): For NC device, the **secure** state is given when a single resistor is detected. The voltage becomes lower than the **Level 3** threshold value (2.9V) and higher than the **Level 2** threshold value (2.25V).

The **alarm** state is given when the input is open or short. The voltage becomes higher than the **Level 4** threshold value (3.75V) or lowers than the **Level 1** threshold value (1.1V). If the alarm switch is programmed as NO device, the **alarm** state will be given when a single resistor is detected.

5. Applying Power

After all wiring is completed, connect the 16 VAC to the KT-400. Connect the battery leads to the battery, and then apply power to the AC transformer.

Note: Do not connect power until all wiring is complete.

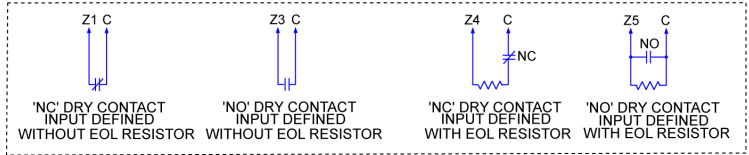
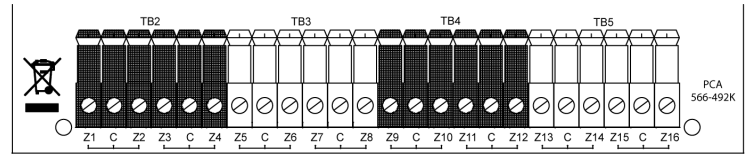

DRY (Without EOL Resistor)

Input	State		Level
	NC	NO	
Open	Alarm	Secure	High
			2
			1
Short	Secure	Alarm	Low

Fixed values for:
Level 1 = 1.1 V
Level 2 = 3.75 V

EOL (With EOL Resistor)

Input	State		Level
	NC	NO	
Open	Alarm	Secure	High
			4
			3
Resistor	Secure	Alarm	2
			1
Short	Alarm	Secure	Low

Fixed values for:
Level 1 = 1.1 V
Level 2 = 2.25 V
Level 3 = 2.9 V
Level 4 = 3.75 V

Terminal Connections

Module no.: _____

Date of installation: _____

KT-400 Name: _____

KT-400 SITE NAME: _____

KT-400 Serial Number: _____

AUX: _____

SPI BUS (FROM): _____

SPI BUS (TO): _____

Z1: _____ Z9: _____

Z2: _____ Z10: _____

Z3: _____ Z11: _____

Z4: _____ Z12: _____

Z5: _____ Z13: _____

Z6: _____ Z14: _____

Z7: _____ Z15: _____

Z8: _____ Z16: _____

FCC & IC COMPLIANCE STATEMENT

CAUTION: Changes or modifications not expressly approved by Kantech could void your authority to use this equipment.

This equipment generates and uses radio frequency energy and if not installed and used properly, in strict accordance with the manufacturer's instructions, may cause interference to radio and television reception. It has been type tested and found to comply with the limits for Class A device in accordance with the specifications of Part 15 of FCC Rules, which are designed to provide reasonable protection against such interference in any residential installation. However, there is no guarantee that interference will not occur in a particular installation. If this equipment does cause interference to television or radio reception, which can be determined by turning the equipment off and on, the user is encouraged to try to correct the interference by one or more of the following measures:

- Re-orient the receiving antenna
- Relocate the alarm control with respect to the receiver
- Move the alarm control away from the receiver
- Connect the alarm control into a different outlet so that alarm control and receiver are on different circuits.

If necessary, the user should consult the dealer or an experienced radio/television technician for additional suggestions. The user may find the following booklet prepared by the FCC helpful: "How to Identify and Resolve Radio/Television Interference Problems". This booklet is available from the U.S. Government Printing Office, Washington, D.C. 20402, Stock # 004-000-00345-4. This device complies with Part 15 of the FCC rules. Operation is subject to the following two conditions: (1) this device may not cause harmful interference, and (2) this device must accept any interference received including interference that may cause undesired operation. This Class A digital apparatus meets all requirements of the Canadian Interference Causing Equipment Regulations. The KT-400 is also compliant with EN55022: 1994, amendment 1: 1995, Class A.

Free Manuals Download Website

<http://myh66.com>

<http://usermanuals.us>

<http://www.somanuals.com>

<http://www.4manuals.cc>

<http://www.manual-lib.com>

<http://www.404manual.com>

<http://www.luxmanual.com>

<http://aubethermostatmanual.com>

Golf course search by state

<http://golfingnear.com>

Email search by domain

<http://emailbydomain.com>

Auto manuals search

<http://auto.somanuals.com>

TV manuals search

<http://tv.somanuals.com>