



Cisco Multiband Wall-Mount Antenna (AIR-ANTM5560P-R)

This document outlines the specifications and describes the AIR-ANTM5560P-R multiband wall-mount antenna and contains the following sections:

- [Cisco 90-Day Limited Hardware Warranty Terms, page 1](#)
- [Overview, page 3](#)
- [Technical Specifications, page 3](#)
- [System Requirements, page 7](#)
- [Installation Guidelines, page 8](#)
- [Safety Instructions, page 9](#)
- [Installation Instructions, page 10](#)
- [Obtaining Documentation, page 13](#)
- [Documentation Feedback, page 14](#)
- [Cisco Product Security Overview, page 14](#)
- [Obtaining Technical Assistance, page 15](#)
- [Obtaining Additional Publications and Information, page 17](#)

Cisco 90-Day Limited Hardware Warranty Terms

There are special terms applicable to your hardware warranty and various services that you can use during the warranty period. Your formal Warranty Statement, including the warranties and license agreements applicable to Cisco software, is available on Cisco.com. Follow these steps to access and download the *Cisco Information Packet* and your warranty and license agreements from Cisco.com.

1. Launch your browser, and go to this URL:

http://www.cisco.com/univercd/cc/td/doc/es_inpk/cetrans.htm

The Warranties and License Agreements page appears.



Corporate Headquarters:
Cisco Systems, Inc., 170 West Tasman Drive, San Jose, CA 95134-1706 USA

© 2005 Cisco Systems, Inc. All rights reserved.

2. To read the *Cisco Information Packet*, follow these steps:
 - a. Click the **Information Packet Number** field, and make sure that the part number 78-5235-03A0 is highlighted.
 - b. Select the language in which you would like to read the document.
 - c. Click **Go**.

The Cisco Limited Warranty and Software License page from the Information Packet appears.

- d. Read the document online, or click the **PDF** icon to download and print the document in Adobe Portable Document Format (PDF).



Note You must have Adobe Acrobat Reader to view and print PDF files. You can download the reader from Adobe’s website: <http://www.adobe.com>

3. To read translated and localized warranty information about your product, follow these steps:
 - a. Enter this part number in the Warranty Document Number field:
78-5236-01C0
 - b. Select the language in which you would like to read the document.
 - c. Click **Go**.

The Cisco warranty page appears.

- d. Review the document online, or click the **PDF** icon to download and print the document in Adobe Portable Document Format (PDF).

You can also contact the Cisco service and support website for assistance:

http://www.cisco.com/public/Support_root.shtml.

Duration of Hardware Warranty

Ninety (90) days.

Replacement, Repair, or Refund Policy for Hardware

Cisco or its service center will use commercially reasonable efforts to ship a replacement part within ten (10) working days after receipt of a Return Materials Authorization (RMA) request. Actual delivery times can vary, depending on the customer location.

Cisco reserves the right to refund the purchase price as its exclusive warranty remedy.

To Receive a Return Materials Authorization (RMA) Number

Contact the company from whom you purchased the product. If you purchased the product directly from Cisco, contact your Cisco Sales and Service Representative.

Complete the information below, and keep it for reference:

Company product purchased from	
Company telephone number	
Product model number	
Product serial number	
Maintenance contract number	

Overview

The AIR-ANTM5560P-R antenna operates in the 2.4- and 5-GHz bands, and is designed for use with spatial-diversity access point (AP) systems. The AIR-ANTM5560P-R antenna is compatible with Cisco 802.11a/b/g radio products using a reverse-polarity threaded Neill-Concelman (RP-TNC) connector.

Figure 1 shows the AIR-ANTM5560P-R antenna.

Figure 1 Cisco AIR-ANTM5560P-R Antenna

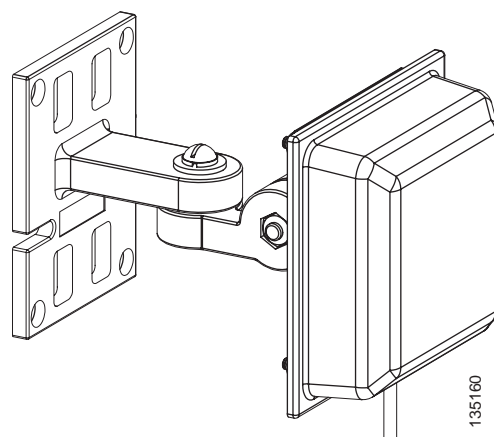

Technical Specifications

The following table lists the technical specifications for AIR-ANTM5560P-R.

Antenna type	Directional panel
Operating frequency range	2400 to 2500 MHz and 4900 to 5990 MHz
Maximum VSWR ¹ bandwidth	2.0:1
Peak gain	<ul style="list-style-type: none"> • 2.4-GHz: 5.5 dBi • 5-GHz: 6 dBi
Polarization	Linear vertical
Azimuth plane beamwidth	<ul style="list-style-type: none"> • 2.4-GHz: 68 degrees • 5-GHz: 52 degrees
Elevation plane 3 dB beamwidth (H-plane)	<ul style="list-style-type: none"> • 2.4-GHz: 68 degrees • 5-GHz: 52 degrees
Elevation plane 3 dB beamwidth (E-plane)	<ul style="list-style-type: none"> • 2.4-GHz: 66 degrees • 5-GHz: 60 degrees
Coaxial cable	10 ft (3 m) plenum rated
Dimensions	4.2 x 4.2 x 1.4 in. (106.7 x 106.7 x 35.6 mm)
Weight	0.5 lb (0.23 kg)

Connector type	RP-TNC
Enclosure	Acrylic/PVC
Environment	Indoor only
Mounting	Wall-mount, pole-mount

1. VSWR = voltage standing wave ratio

Figure 2 shows the H-plane radiation pattern at 2.4- to 2.5-GHz for the AIR-ANTM5560P-R antenna.

Figure 2 H-Plane Pattern at 2.4- to 2.5-GHz

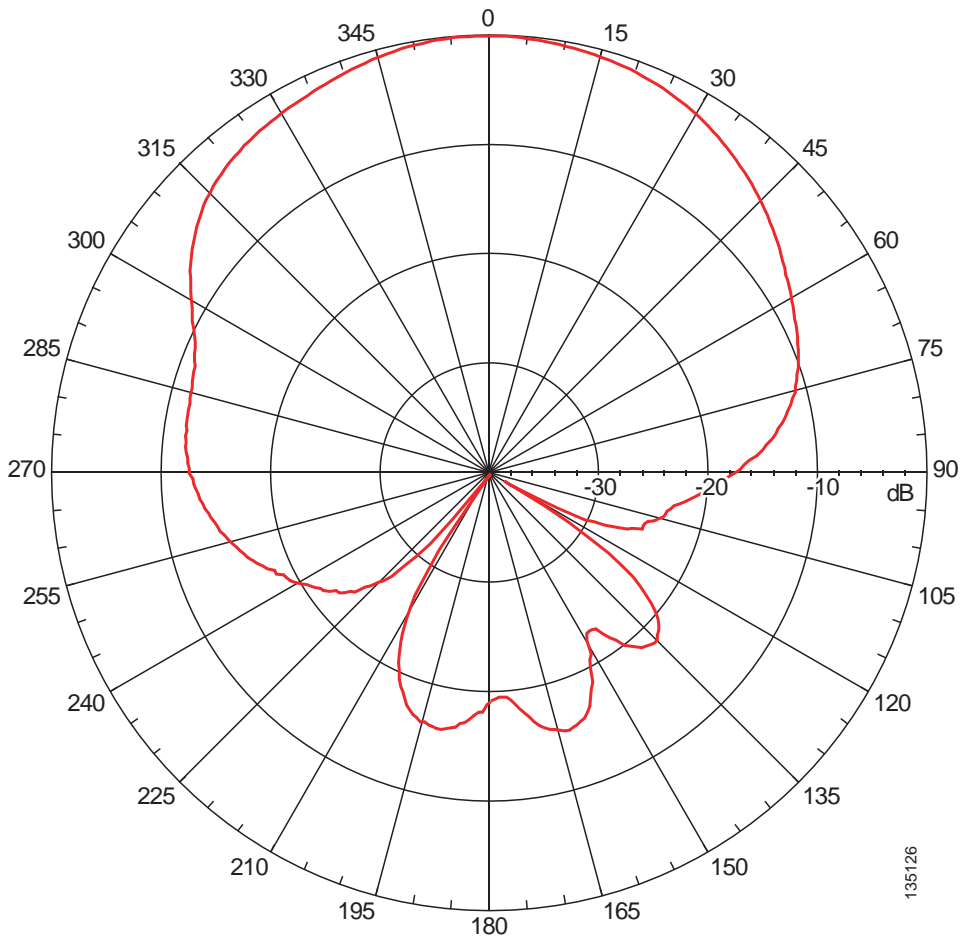

Figure 3 shows the E-plane radiation pattern at 2.4- to 2.5-GHz for the AIR-ANTM5560P-R antenna.

Figure 3 *E-Plane Pattern at 2.4- to 2.5-GHz*

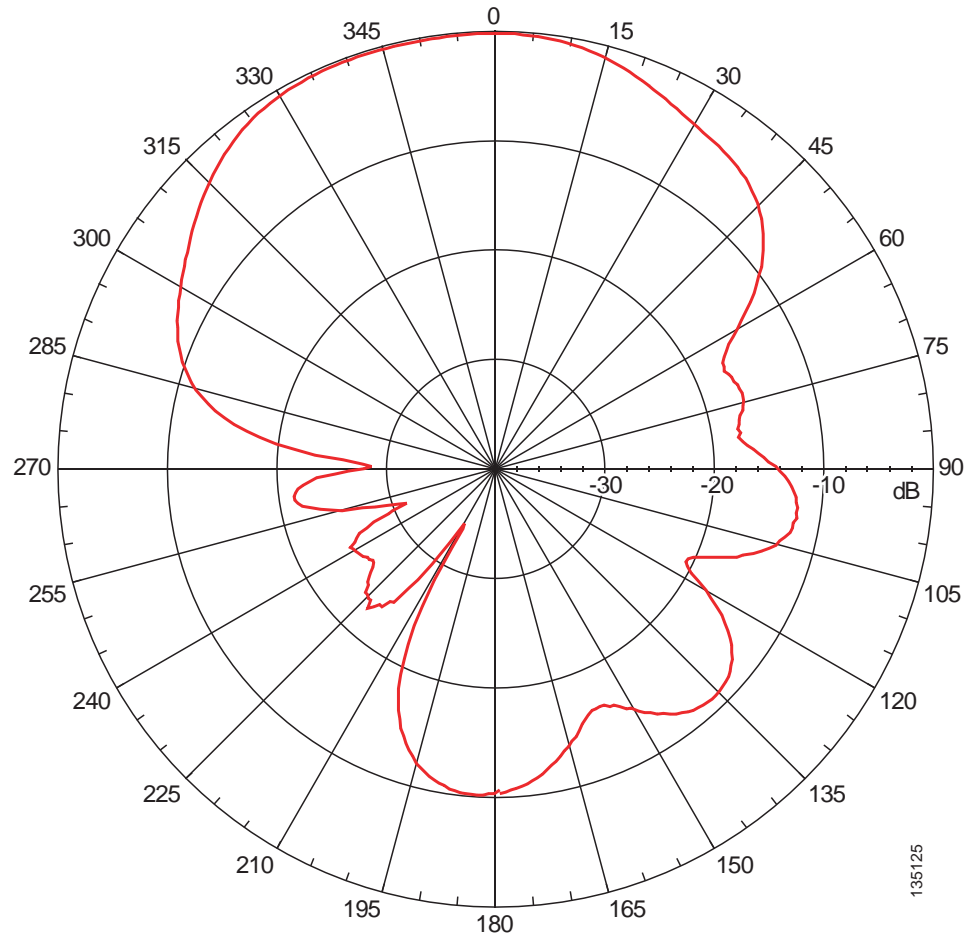

Figure 4 shows the H-plane radiation pattern at 4.9- to 5.99-GHz for the AIR-ANTM5560P-R antenna.

Figure 4 H-Plane Pattern at 4.9- to 5.99-GHz

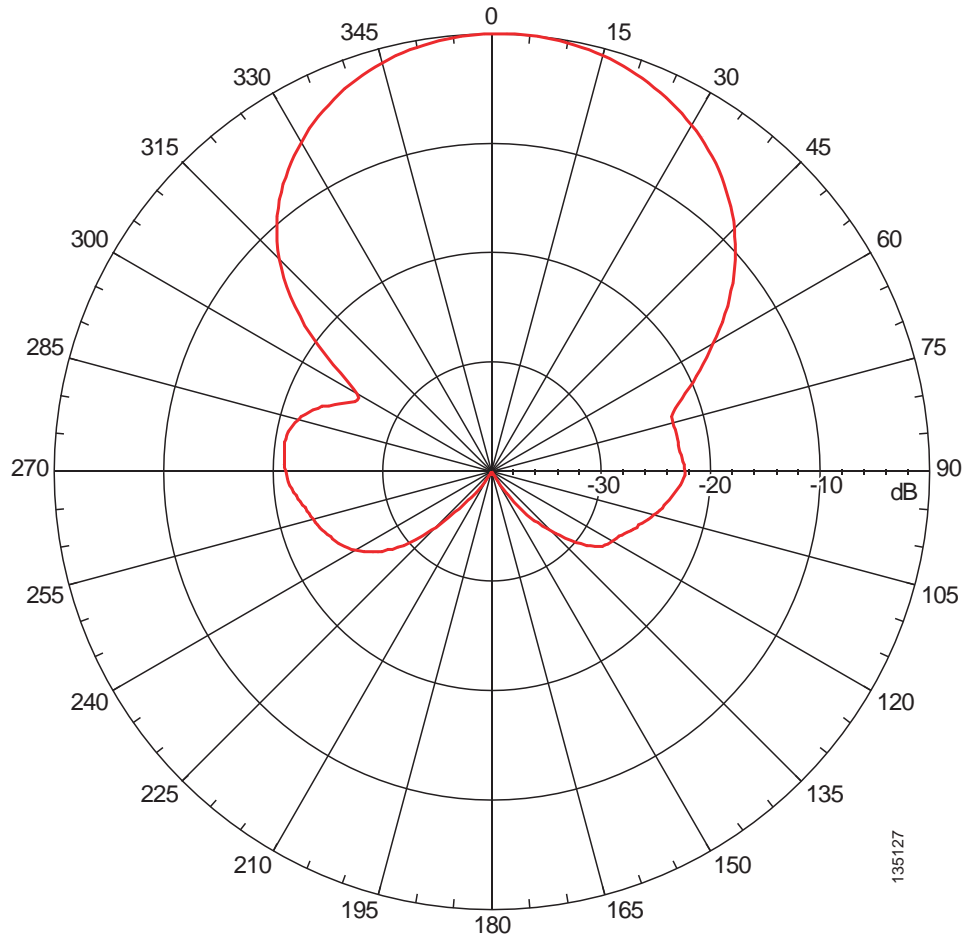
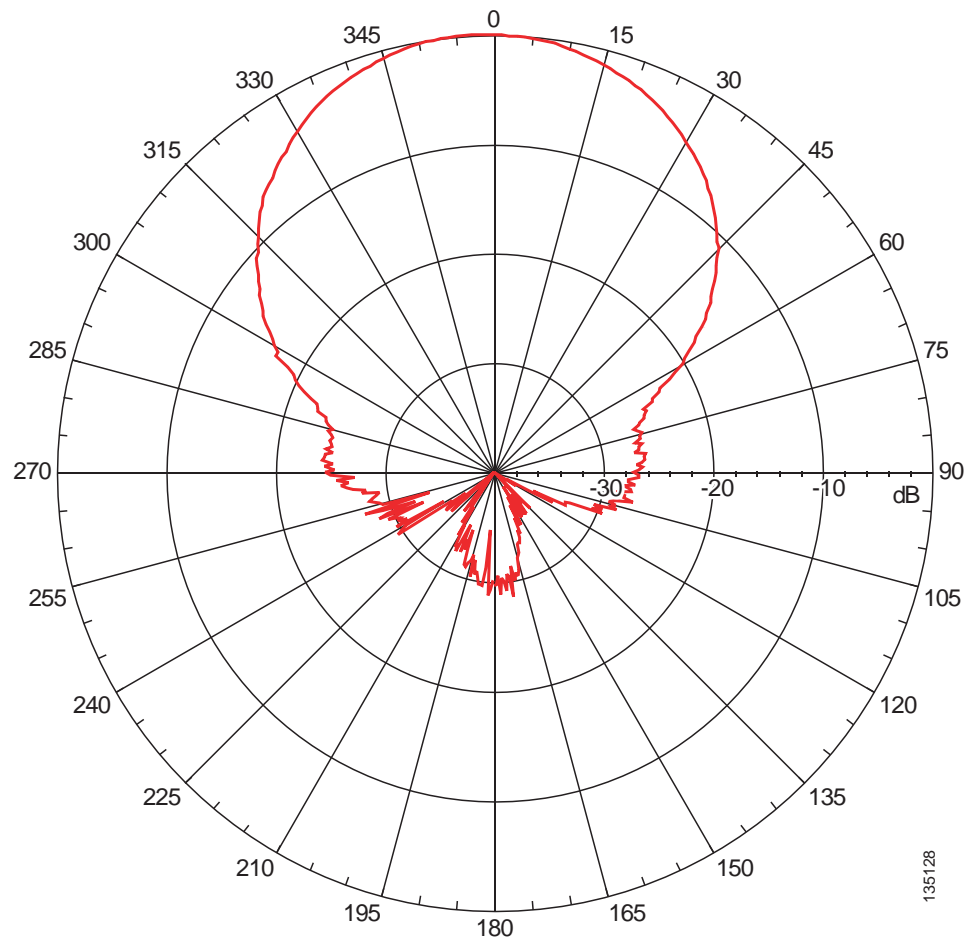

Figure 5 shows the E-plane radiation pattern at 4.9- to 5.99-GHz for the AIR-ANTM5560P-R antenna.

Figure 5 E-Plane Pattern at 4.9- to 5.99-GHz



System Requirements

The AIR-ANTM5560P-R antenna requires a Cisco 802.11a/b/g radio product that uses a RP-TNC connector.

Installation Guidelines

In addition to antenna orientation, wireless access point installation location with respect to all wireless clients plays a significant role in determining overall network performance. Clients at the furthest coverage points might have 10% to 50% of the bandwidth of clients close to it. Wireless network coverage in one area or location might need to be lowered to improve the performance of other clients.

Because antennas transmit and receive radio signals, their performance can be adversely affected by the surrounding environment including distance between access point and client, physical obstructions, or radio frequency (RF) interference.

Follow these guidelines to ensure the best possible performance:

- Mount the antenna to use its propagation characteristics. One way to do this is to orient the antenna vertically and mount it as high as possible.



Note This antenna must be mounted vertically in order to maximize its directional propagation characteristics. Mounting it horizontally may noticeably decrease the antenna's range and overall performance.

- Wherever possible, mount the AP HWIC and antenna where the wireless devices would be within sight and avoid physical obstructions. Barriers along the line of sight between client and access point will degrade the wireless radio signals. AP HWICs and antennas can be installed above floor level in office environments or near the ceiling for better performance since most obstructions tend to be near floor level.
- The density of the materials used in a building's construction determines the number of walls the signal must pass through and still maintain adequate coverage. Consider the following before choosing the location to install your antenna:
 - Paper and vinyl walls have very little effect on signal penetration.
 - Solid and precast concrete walls limit signal penetration to one or two walls without degrading coverage.
 - Concrete and wood block walls limit signal penetration to three or four walls.
 - A signal can penetrate five or six walls constructed of drywall or wood.
 - A thick metal wall or wire-mesh stucco walls causes signals to reflect back and cause poor penetration.
- Avoid mounting the antenna next to a column or vertical support that could create a shadow zone and reduce the coverage area.
- Keep the antenna away from reflective metal objects such as heating and air-conditioning ducts, large ceiling trusses, building superstructures, and major power cabling runs. If necessary, use an extension cable to relocate the antenna away from these obstructions.

**Caution**

Install the AP HWIC and any antennas away from appliances that share the same frequency bands. Microwave ovens, cordless telephones, and security monitors can temporarily interfere with wireless performance.

**Caution**

We recommend you avoid installing wireless antennas in or near rack-mounted installations that include networking equipment and computer servers whose radiated noise emissions can severely degrade radio performance.

- To extend the coaxial cable included with your antenna, we recommend a low-loss or ultra-low-loss coaxial cable for installation flexibility without a significant loss in range. The following table lists transmission loss information about low-loss and ultra-low-loss extension coaxial cables available from Cisco.

Cisco Product Number	Cable Length	Transmission Loss
AIR-CAB020LL-R	20 ft (6 m)	<ul style="list-style-type: none"> • 2.4-GHz: 1.3 dBi • 5-GHz: 2.5 dBi
AIR-CAB050LL-R	50 ft (15 m)	<ul style="list-style-type: none"> • 2.4-GHz: 3.3 dBi • 5-GHz: 5.75 dBi
AIR-CAB100ULL-R	100 ft (30 m)	<ul style="list-style-type: none"> • 2.4-GHz: 4.4 dBi • 5-GHz: 7.25 dBi
AIR-CAB150ULL-R	150 ft (46 m)	<ul style="list-style-type: none"> • 2.4-GHz: 6.6 dBi • 5-GHz: 11 dBi

Safety Instructions

Follow these safety precautions when installing your antenna.

**Warning**

In order to comply with FCC radio frequency (RF) exposure limits, antennas should be located at a minimum of 7.9 inches (20 cm) or more from the body of all persons. Statement 332

- Plan your installation procedure carefully and completely before you begin.
- If you are installing an antenna for the first time, for your own safety as well as that of others, seek *professional assistance*. Consult your dealer, who can explain which mounting method to use for the location where you intend to install the antenna.
- Choose your installation site with safety as well as performance in mind. Remember that electric power lines and telephone lines look alike. For your safety, assume that any line is an electric power line until determined otherwise.
- Call your local power company or building maintenance organization if you are unsure about cables close to your intended mounting location.
- If an accident or emergency occurs with the power lines, call for qualified emergency help immediately.
- When installing your antenna in any location, *do not* use a metal ladder. *Do* dress properly: shoes with rubber soles and heels, rubber gloves, and a long sleeved shirt or jacket. When drilling mounting holes, wear safety glasses.

Installation Instructions

The following sections contain procedures for installing the antenna on a wall or pole. The following parts are included with your antenna:

- Molded antenna mount
- Molded wall mount
- Articulating arm
- Four 8-32 nylon lock nuts
- Two 1/4-in. lock washers
- Two 1/4-in. flat washers
- Two 1/4-20 x 1-1/4-in. machine screws
- Two 1/4-20 hex nuts

For mounting on a wall:

- Four wall anchors
- Four 8-18 x 3/4-in. self-tapping Phillips screws

For mounting on a pole:

- Two worm tie clamps

Tools and Equipment Required

To install the antenna, you will need the following tools and equipment:

- Adjustable wrench
- A Phillips screwdriver
- A pencil

For mounting on a wall:

- A portable hand or electric drill
- A 3/16 in. (4.7 mm) drill bit

For mounting on a pole:

- A small flat-blade screwdriver

Mounting on a Wall

This section provides instructions for mounting the antenna on a wall. (See [Figure 6.](#))

Figure 6 *Mounting the Antenna on a Wall*

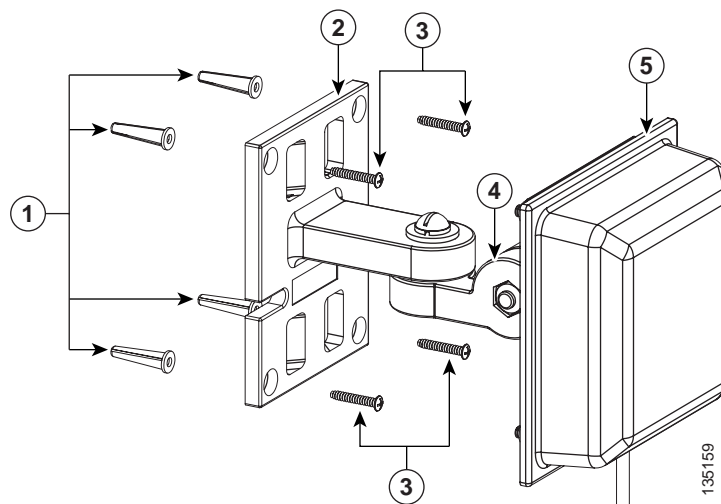

1	Wall anchors	2	Molded wall mount
3	8-18 x 3/4-in. self-tapping Phillips screws	4	Articulating arm
5	Molded antenna mount		

To mount the antenna on a wall, follow these steps:

- Step 1** Choose a location for mounting.
- Step 2** If an extension coaxial cable is used, connect it to the access point and extend the coaxial cable to the location for mounting the antenna.
- Step 3** Attach the antenna to the molded antenna mount using the four provided 8-32 nylon lock nuts.
- Step 4** Attach the antenna mount to the articulating arm (all mounting hardware is provided):
 - a. Place a 1/4-in. lock washer, then a 1/4-in. flat washer on a 1/4-20 x 1-1/4-in. machine screw.
 - b. Insert the screw and washers, first through the molded antenna mount, then the articulating arm.
 - c. Secure the articulating arm to the molded antenna mount using a 1/4-20 hex nut.
- Step 5** Find the molded wall mount and position it on the mounting surface. Use a pencil to mark the location of the mounting holes. There are four holes for wall-mounting, one in each corner.
- Step 6** Using a 3/16-in. (4.7 mm) drill bit, drill holes for the screws at the locations you marked in [Step 5](#).
- Step 7** Route the cable either up or down from the wall or corner.
- Step 8** Install a wall anchor in each hole.
- Step 9** Line up the mounting holes on the molded wall mount with the pilot holes and start one of the provided 8-18 x 3/4-in. self-tapping Phillips screws in each hole.
- Step 10** Tighten the screws with a Philips screwdriver.
- Step 11** Attach the articulating arm to the molded wall mount (all hardware is provided):
 - a. Place a 1/4-in. lock washer, then a 1/4-in. flat washer on a 1/4-20 x 1-1/4-in. machine screw.
 - b. Insert the screw and washers, first through the molded wall mount, then the articulating arm.
 - c. Secure the articulating arm to the molded wall mount using a 1/4-20 hex nut.

- Step 12 Loosen the screws on the articulating arm to position the antenna as desired. When you are finished positioning the antenna, tighten all the screws.
- Step 13 If an extension coaxial cable is used, connect it to the antenna cable.

Mounting on a Pole

This section provides instructions for mounting the antenna on a pole. (See [Figure 7](#).)

Figure 7 *Mounting the Antenna on a Pole*

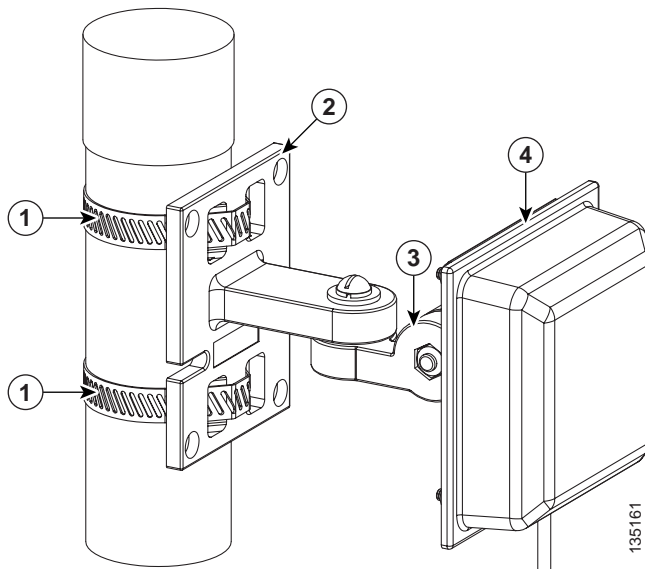

1	Worm tie clamps	2	Molded wall mount
3	Articulating arm	4	Molded antenna mount

To mount the antenna on a pole, follow these steps:

- Step 1 Choose a location for mounting. The diameter of the mast must be from 1.5 in. to 2.5 in. (25 mm to 70 mm).
- Step 2 If an extension coaxial cable is used, connect it to the access point and extend the coaxial cable to the location for mounting the antenna.
- Step 3 Attach the antenna to the molded antenna mount using the four provided 8-32 nylon lock nuts.
- Step 4 Attach the antenna mount to the articulating arm (all mounting hardware is provided):
 - a. Place a 1/4-in. lock washer, then a 1/4-in. flat washer on a 1/4-20 x 1-1/4-in. machine screw.
 - b. Insert the screw and washers, first through the molded antenna mount, then the articulating arm.
 - c. Secure the articulating arm to the molded antenna mount using a 1/4-20 hex nut.
- Step 5 Thread the two worm tie clamps provided through the four square holes of the molded wall mount.
- Step 6 Wrap the worm tie clamps around the pole and tighten them using a small flat-head screwdriver.

- Step 7** Attach the articulating arm to the molded wall mount (all hardware is provided):
- Place a 1/4-in. lock washer, then a 1/4-in. flat washer on a 1/4-20 x 1-1/4" machine screw.
 - Insert the screw and washers, first through the molded wall mount, then the articulating arm.
 - Secure the articulating arm to the molded wall mount using a 1/4-20 hex nut.
- Step 8** Loosen the screws on the articulating arm to position the antenna as desired. When you are finished positioning the antenna, tighten all the screws.
- Step 9** If an extension coaxial cable is used, connect it to the antenna cable.
-

Obtaining Documentation

Cisco documentation and additional literature are available on Cisco.com. Cisco also provides several ways to obtain technical assistance and other technical resources. These sections explain how to obtain technical information from Cisco Systems.

Cisco.com

You can access the most current Cisco documentation at this URL:

<http://www.cisco.com/univercd/home/home.htm>

You can access the Cisco website at this URL:

<http://www.cisco.com>

You can access international Cisco websites at this URL:

http://www.cisco.com/public/countries_languages.shtml

Documentation DVD

Cisco documentation and additional literature are available in a Documentation DVD package, which may have shipped with your product. The Documentation DVD is updated regularly and may be more current than printed documentation. The Documentation DVD package is available as a single unit.

Registered Cisco.com users (Cisco direct customers) can order a Cisco Documentation DVD (product number DOC-DOCDVD=) from the Ordering tool or Cisco Marketplace.

Cisco Ordering tool:

<http://www.cisco.com/en/US/partner/ordering/>

Cisco Marketplace:

<http://www.cisco.com/go/marketplace/>

Ordering Documentation

You can find instructions for ordering documentation at this URL:

http://www.cisco.com/univercd/cc/td/doc/es_inpk/pdi.htm

You can order Cisco documentation in these ways:

- Registered Cisco.com users (Cisco direct customers) can order Cisco product documentation from the Ordering tool:

<http://www.cisco.com/en/US/partner/ordering/>

- Nonregistered Cisco.com users can order documentation through a local account representative by calling Cisco Systems Corporate Headquarters (California, USA) at 408 526-7208 or, elsewhere in North America, by calling 1 800 553-NETS (6387).

Documentation Feedback

You can send comments about technical documentation to bug-doc@cisco.com.

You can submit comments by using the response card (if present) behind the front cover of your document or by writing to the following address:

Cisco Systems
Attn: Customer Document Ordering
170 West Tasman Drive
San Jose, CA 95134-9883

We appreciate your comments.

Cisco Product Security Overview

Cisco provides a free online Security Vulnerability Policy portal at this URL:

http://www.cisco.com/en/US/products/products_security_vulnerability_policy.html

From this site, you can perform these tasks:

- Report security vulnerabilities in Cisco products.
- Obtain assistance with security incidents that involve Cisco products.
- Register to receive security information from Cisco.

A current list of security advisories and notices for Cisco products is available at this URL:

<http://www.cisco.com/go/psirt>

If you prefer to see advisories and notices as they are updated in real time, you can access a Product Security Incident Response Team Really Simple Syndication (PSIRT RSS) feed from this URL:

http://www.cisco.com/en/US/products/products_psirt_rss_feed.html

Reporting Security Problems in Cisco Products

Cisco is committed to delivering secure products. We test our products internally before we release them, and we strive to correct all vulnerabilities quickly. If you think that you might have identified a vulnerability in a Cisco product, contact PSIRT:

- Emergencies—security-alert@cisco.com
- Nonemergencies—psirt@cisco.com



Tip

We encourage you to use Pretty Good Privacy (PGP) or a compatible product to encrypt any sensitive information that you send to Cisco. PSIRT can work from encrypted information that is compatible with PGP versions 2.x through 8.x.

Never use a revoked or an expired encryption key. The correct public key to use in your correspondence with PSIRT is the one that has the most recent creation date in this public key server list:

<http://pgp.mit.edu:11371/pks/lookup?search=psirt%40cisco.com&op=index&exact=on>

In an emergency, you can also reach PSIRT by telephone:

- 1 877 228-7302
- 1 408 525-6532

Obtaining Technical Assistance

For all customers, partners, resellers, and distributors who hold valid Cisco service contracts, Cisco Technical Support provides 24-hour-a-day, award-winning technical assistance. The Cisco Technical Support Website on Cisco.com features extensive online support resources. In addition, Cisco Technical Assistance Center (TAC) engineers provide telephone support. If you do not hold a valid Cisco service contract, contact your reseller.

Cisco Technical Support Website

The Cisco Technical Support Website provides online documents and tools for troubleshooting and resolving technical issues with Cisco products and technologies. The website is available 24 hours a day, 365 days a year, at this URL:

<http://www.cisco.com/techsupport>

Access to all tools on the Cisco Technical Support Website requires a Cisco.com user ID and password. If you have a valid service contract but do not have a user ID or password, you can register at this URL:

<http://tools.cisco.com/RPF/register/register.do>

**Note**

Use the Cisco Product Identification (CPI) tool to locate your product serial number before submitting a web or phone request for service. You can access the CPI tool from the Cisco Technical Support Website by clicking the **Tools & Resources** link under Documentation & Tools. Choose **Cisco Product Identification Tool** from the Alphabetical Index drop-down list, or click the **Cisco Product Identification Tool** link under Alerts & RMAs. The CPI tool offers three search options: by product ID or model name; by tree view; or for certain products, by copying and pasting **show** command output. Search results show an illustration of your product with the serial number label location highlighted. Locate the serial number label on your product and record the information before placing a service call.

Submitting a Service Request

Using the online TAC Service Request Tool is the fastest way to open S3 and S4 service requests. (S3 and S4 service requests are those in which your network is minimally impaired or for which you require product information.) After you describe your situation, the TAC Service Request Tool provides recommended solutions. If your issue is not resolved using the recommended resources, your service request is assigned to a Cisco TAC engineer. The TAC Service Request Tool is located at this URL:

<http://www.cisco.com/techsupport/servicerequest>

For S1 or S2 service requests or if you do not have Internet access, contact the Cisco TAC by telephone. (S1 or S2 service requests are those in which your production network is down or severely degraded.) Cisco TAC engineers are assigned immediately to S1 and S2 service requests to help keep your business operations running smoothly.

To open a service request by telephone, use one of the following numbers:

Asia-Pacific: +61 2 8446 7411 (Australia: 1 800 805 227)

EMEA: +32 2 704 55 55

USA: 1 800 553-2447

For a complete list of Cisco TAC contacts, go to this URL:

<http://www.cisco.com/techsupport/contacts>

Definitions of Service Request Severity

To ensure that all service requests are reported in a standard format, Cisco has established severity definitions.

Severity 1 (S1)—Your network is “down,” or there is a critical impact to your business operations. You and Cisco will commit all necessary resources around the clock to resolve the situation.

Severity 2 (S2)—Operation of an existing network is severely degraded, or significant aspects of your business operation are negatively affected by inadequate performance of Cisco products. You and Cisco will commit full-time resources during normal business hours to resolve the situation.

Severity 3 (S3)—Operational performance of your network is impaired, but most business operations remain functional. You and Cisco will commit resources during normal business hours to restore service to satisfactory levels.

Severity 4 (S4)—You require information or assistance with Cisco product capabilities, installation, or configuration. There is little or no effect on your business operations.

Obtaining Additional Publications and Information

Information about Cisco products, technologies, and network solutions is available from various online and printed sources.

- Cisco Marketplace provides a variety of Cisco books, reference guides, and logo merchandise. Visit Cisco Marketplace, the company store, at this URL:

<http://www.cisco.com/go/marketplace/>

- *Cisco Press* publishes a wide range of general networking, training and certification titles. Both new and experienced users will benefit from these publications. For current Cisco Press titles and other information, go to Cisco Press at this URL:

<http://www.ciscopress.com>

- *Packet* magazine is the Cisco Systems technical user magazine for maximizing Internet and networking investments. Each quarter, Packet delivers coverage of the latest industry trends, technology breakthroughs, and Cisco products and solutions, as well as network deployment and troubleshooting tips, configuration examples, customer case studies, certification and training information, and links to scores of in-depth online resources. You can access Packet magazine at this URL:

<http://www.cisco.com/packet>

- *iQ Magazine* is the quarterly publication from Cisco Systems designed to help growing companies learn how they can use technology to increase revenue, streamline their business, and expand services. The publication identifies the challenges facing these companies and the technologies to help solve them, using real-world case studies and business strategies to help readers make sound technology investment decisions. You can access iQ Magazine at this URL:

<http://www.cisco.com/go/iqmagazine>

- *Internet Protocol Journal* is a quarterly journal published by Cisco Systems for engineering professionals involved in designing, developing, and operating public and private internets and intranets. You can access the Internet Protocol Journal at this URL:

<http://www.cisco.com/ipj>

- World-class networking training is available from Cisco. You can view current offerings at this URL:

<http://www.cisco.com/en/US/learning/index.html>

CCSP, CCVP, the Cisco Square Bridge logo, Follow Me Browsing, and StackWise are trademarks of Cisco Systems, Inc.; Changing the Way We Work, Live, Play, and Learn, and iQuick Study are service marks of Cisco Systems, Inc.; and Access Registrar, Aironet, ASIST, BPX, Catalyst, CCDA, CCDP, CCIE, CCIP, CCNA, CCNP, Cisco, the Cisco Certified Internetwork Expert logo, Cisco IOS, Cisco Press, Cisco Systems, Cisco Systems Capital, the Cisco Systems logo, Cisco Unity, Empowering the Internet Generation, Enterprise/Solver, EtherChannel, EtherFast, EtherSwitch, Fast Step, FormShare, GigaDrive, GigaStack, HomeLink, Internet Quotient, IOS, IP/TV, iQ Expertise, the iQ logo, iQ Net Readiness Scorecard, LightStream, Linksys, MeetingPlace, MGX, the Networkers logo, Networking Academy, Network Registrar, *Packet*, PIX, Post-Routing, Pre-Routing, ProConnect, RateMUX, ScriptShare, SlideCast, SMARTnet, StrataView Plus, TeleRouter, The Fastest Way to Increase Your Internet Quotient, and TransPath are registered trademarks of Cisco Systems, Inc. and/or its affiliates in the United States and certain other countries.

All other trademarks mentioned in this document or Website are the property of their respective owners. The use of the word partner does not imply a partnership relationship between Cisco and any other company. (0502R)

Copyright © 2005 Cisco Systems, Inc. All rights reserved.

Free Manuals Download Website

<http://myh66.com>

<http://usermanuals.us>

<http://www.somanuals.com>

<http://www.4manuals.cc>

<http://www.manual-lib.com>

<http://www.404manual.com>

<http://www.luxmanual.com>

<http://aubethermostatmanual.com>

Golf course search by state

<http://golfingnear.com>

Email search by domain

<http://emailbydomain.com>

Auto manuals search

<http://auto.somanuals.com>

TV manuals search

<http://tv.somanuals.com>