

SERVICE *Manual*

WorkCentre PE16



CONTENTS

1. Precautions
2. Reference Information
3. Specifications
4. Summary of product
5. Disassembly and Reassembly
6. Alignment and Adjustments
7. Troubleshooting
8. Exploded Views and Parts List
9. Block Diagram
10. Connection Diagram

1. Precautions

Product Terms

Caution: A personal injury hazard exists that may not be apparent. For example, a panel may cover the hazardous area.

Danger: A personal injury hazard exists in the area where you see the sign.

Symbols Marked on the Product



Hot surface on or in the printer. Use caution to avoid personal injury.



Use caution (or draws attention to a particular component). Refer to the manual(s) for information.

Laser Safety Statement

The Printer is certified in the U.S. to conform to the requirements of DHHS 21 CFR, chapter 1 Subchapter J for Class 1(1) laser products, and elsewhere, it is certified as a Class I laser product conforming to the requirements of IEC 60825. Class I laser products are not considered to be hazardous. The laser system and printer are designed so there is never any human access to laser radiation above a Class I level during normal operation, user maintenance, or prescribed service condition.

Warning >> Never operate or service the printer with the protective cover removed from Laser/Scanner assembly. The reflected beam, although invisible, can damage your eyes. When using this product, these basic safety precautions should always be followed to reduce risk of fire, electric shock, and injury to persons.



CAUTION - INVISIBLE LASER RADIATION
WHEN THIS COVER OPEN.
DO NOT OPEN THIS COVER.

VORSICHT - UNSICHTBARE LASERSTRAHLUNG,
WENN ABDECKUNG GEFFNET.
NICHT DEM STRAHL AUSSETZEN.

ATTENTION - RAYONNEMENT LASER INVISIBLE EN CAS
D'OUVERTURE. EXPOSITION DANGEREUSE
AU FAISCEAU.

ATTENZIONE - RADIAZIONE LASER INVISIBLE IN CASO DI
APERTURA. EVITARE L'ESPOSIZIONE AL
FASCIO.

PRECAUCION - RADIACION LASER INVISIBLE CUANDO SE ABRE.
EVITAR EXPONERSE AL RAYO.

ADVARSEL - USYNLIG LASERSTRÅLING VED ÅBNING, NÅR
SIKKERHEDSBRYDERE ER UDE AF FUNKTION.
UNDG. UDSÆTTELSE FOR STRÅLING.

ADVARSEL - USYNLIG LASERSTRÅLING NÅR DEKSEL
ÅPNES. STIRR IKKE INN I STRÅLEN.
UNNG. EKSPONERING FOR STRÅLEN.

VARNING - OSYNLIG LASERSTRÅLING NÅR DENNA DEL
ÅPPNAD OCH SPRÄNDRÅR URKOPPLAD.
BETRAKTA EJ STRÅLEN. STRÅLEN ÅR FARLIG.

VARO! - AVATTAESSA JA SUOJALUKITUS OHITETTAESSA
OLET ALTTIINA NÄKYMÄT MÄLLE LASER-
SÄTEILYLLE. LÄKÄTÄS TÄESEEEN.

注 意 - 严禁揭开此盖, 以免激光泄露灼伤

주 의 - 이 덮개를 열면 레이저광에 노출될 수 있으므로
주의하십시오.

Power Safety Precautions

Power Source

For 110 VAC units, do not apply more than 140 volts RMS between the supply conductors or between either supply conductor and ground. Use only the specified power cord and connector. For 220 VAC units, do not apply more than 264 volts RMS between the supply conductors or between either supply conductor and ground. Use only the specified power cord. This manual assumes that the reader is a qualified service technician.

Plug the three-wire power cord (with grounding prong) into a grounded AC outlet only. If necessary, contact a licensed electrician to install a properly grounded outlet. If the product loses its ground connection, contact with conductive parts may cause an electrical shock.

Disconnecting Power

Turning the power off using the On/Off switch does not completely de-energize the equipment. You must also disconnect the unit power cord from the AC outlet. Position the power cord so that it is easily accessible during servicing so that you may power down the unit during an emergency.

Disconnect the power plug by pulling the plug, not the cord.

Disconnect the power cord in the following cases:

- if the power cord or plug is frayed or otherwise damaged,
- if any liquid or foreign material is spilled into the case,
- if the equipment is exposed to any excess moisture,
- if the equipment is dropped or damaged,
- if you suspect that the product needs servicing or repair,
- whenever you clean the product.

Electrostatic Discharge (ESD) Precautions

Some semiconductor components, and the respective sub-assemblies that contain them, are vulnerable to damage by Electrostatic discharge (ESD). These components include Integrated Circuits (ICs), Large-Scale Integrated circuits (LSIs), field-effect transistors and other semiconductor chip components. The following techniques will reduce the occurrence of component damage caused by static electricity.

Be sure the power to the chassis or circuit board is off, and observe all other safety precautions.

- Before handling any semiconductor components assemblies, drain the electrostatic charge from your body. This can be accomplished by touching an earth ground source or by wearing a wrist strap device connected to an earth ground source. Wearing a wrist strap will also prevent accumulation of additional bodily static charges. Be sure to remove the wrist strap before applying power to the unit to avoid potential shock.
- After removing a static sensitive assembly from its anti-static bag, place it on a grounded conductive surface. If the anti-static bag is conductive, you may ground the bag and use it as a conductive surface.
- Do not use freon-propelled chemicals, as they can generate electrical charges that may damage some devices.
- Do not remove a static sensitive replacement component or electrical sub-assembly from its protective package until you are ready to install it.
- Before removing the protective material from the leads of a replacement device, touch the protective material to the chassis or circuit assembly into which the device will be installed.
- Minimize body motions when handling unpackaged replacement devices. Simple motions such as your clothes brushing together or lifting a foot from a carpeted floor can generate enough static electricity to damage a static sensitive device
- Handle IC's and EPROM's carefully to avoid bending pins.
- Pay attention to the direction of parts when mounting or inserting them on Printed Circuit Boards (PCB's).

Service Safety Summary

General Guidelines

Note

The material presented here is intended as a safety reminder for qualified service personnel. Refer also to the preceding Power Safety Precautions.

Avoid servicing alone: Do not perform internal service or adjustment of this product unless another person capable of rendering first aid or resuscitation is present.

Use care when servicing with power: Dangerous voltages may exist at several points in this product. To avoid personal injury, do not touch exposed connections and components while power is on. Disconnect power before removing the power supply shield or replacing components.

Do not wear jewelry: Remove jewelry prior to servicing. Rings, necklaces and other metallic objects could come into contact with dangerous voltages and currents.

Power source: This product is intended to operate from a power source that will not apply more than 264 volts rms for a 220 volt AC outlet or 140 volts rms for a 110 volt AC outlet between the supply conductors or between either supply conductor and ground. A protective ground connection by way of the grounding conductor in the power cord is essential for safe operation.

Warning Labels

Read and obey all posted warning labels. Warning labels are displayed on potentially dangerous printer components. As you service the printer, check to make certain that all warning labels remain in place.

Safety Interlocks

Make sure all covers and the products's front panel are in place and all interlock switches are functioning correctly after you have completed a unit service call. If you bypass an interlock switch during a service call, use extreme caution when working on or around the product.

Servicing Electrical Components

Before starting any service procedure, switch off the product power and unplug the power cord from the wall outlet. If you must service the unit with power applied, be aware of the potential for electrical shock.

Warning

Turning the power off by using the On/Off switch does not completely de-energize the unit. You must also disconnect the unit's power cord from the AC outlet. Position the power cord so that it is easily accessible during servicing.

Warning

Do not touch any electrical component unless you are instructed to do so by a service procedure.



Servicing Mechanical Components

When servicing mechanical components within the unit, manually rotate drive assemblies, rollers, and gears.

Warning

Do not try to manually rotate or manually stop the drive assemblies while any unit drive motor is running.

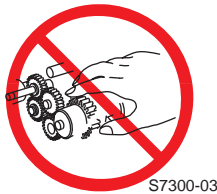

Servicing Fuser Components

Warning

This product uses heat to fuse the toner image to media. The Fuser Assembly is VERY HOT. Turn the unit power off and wait at least 5 minutes for the Fuser to cool before you attempt to service the Fuser Assembly or adjacent components.

2. Reference Information

This chapter provides reference information for this service manual consisting of the tool list, a list of acronyms and abbreviations, and examples of test patterns.

2.1 Tool for Troubleshooting

The following tools are recommended for performance of the troubleshooting functions described in this service manual.

1

DVM(Digital Volt Meter)

Standard: Indicates more than 3 digits.

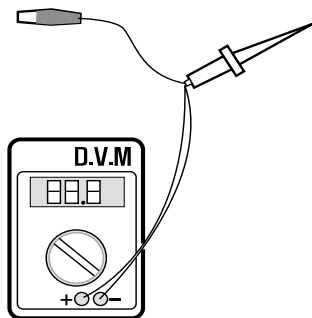

4

Cotton Swab

Standard : For general home use, for medical service.



2

Tweezers

Standard: For general home use, small type.

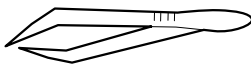

5

Cleaning Equipment IPA (Isopropyl Alcohol) dry cloth or a liquid neutral detergent.

3

Driver

Standard : "-" type, "+" type (M3 long, M3 short, M2 long, M2 short).

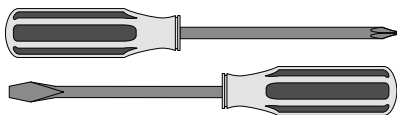

6

Software(Driver) installation CD ROM

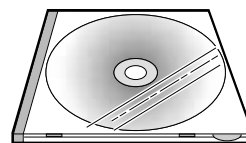

2.2 Acronyms and Abbreviations

The table below explains the acronyms and abbreviations used in this service manual. These are used throughout the text of this service manual. Please refer to the table.

AC	Alternating Current	IDE	Intelligent Drive electronics or Imbedded Drive Electronics
ADF	Automatic Document Feeder	IEEE	Institute of Electrical and Electronics Engineers. Inc
ASIC	Application Specific Integrated Circuit	IPA	Isopropyl Alcohol
ASSY	assembly	IPM	Images Per Minute
BIOS	Basic Input Output System	Kg	Kilogram
CCD	Charge Coupled Device	LAN	local area network
CMOS	Complementary Metal Oxide Semiconductor	lb	pound(s)
CN	connector	LBP	Laser Beam Printer
CON	connector	LCD	Liquid Crystal Display
CPU	Central Processing Unit	LED	Light Emitting Diode
dB	decibel	LSU	Laser Scanning Unit
dbA	decibelampere	MB	Megabyte
dBm	decibel milliwatt	MHz	Megahertz
DC	direct current	NVRAM	Nonvolatile random access memory
DCU	Diagnostic Control Unit	OPC	Organic Photo Conductor
DPI	Dot Per Inch	PBA	Printed Board Assembly
DRAM	Dynamic Random Access Memory	PCL	Printer Command Language , Printer Control Language
DVM	Digital Voltmeter	PDL	Page Discription Language
ECP	Enhanced Capability Port	PPM	Page Per Minute
EEPROM	Electronically Erasable Programmable Read Only Memory	PTL	Pre-Transfer Lamp
EMI	Electro Magnetic Interference	Q'ty	Quantity
EP	electrophotographic	RAM	Random Access Memory
EPP	Enhanced Parallel Port	ROM	Read Only Memory
F/W	firmware	SCF	Second Cassette Feeder
GDI	graphics device interface	SMPS	Switching Mode Power Supply
GND	ground	SPGP	Samsung Printer Graphic Processor
HBP	Host Based Printing	SPL	Samsung Printer Language
HDD	Hard Disk Drive	Spool	Simultaneous Peripheral Operation Online
HV	high voltage	SW	Switch
HVPS	High Voltage Power Supply	Sync	Synchronous or synchronization
I/F	interface	USB	Universal Serial Bus
I/O	Input and Output		
IC	integrated circuit		

2.3 The Sample Test Patterns

The following test patterns are the standard patterns used to test the product in the factory. Cartridge life span and printing speed are measured with the patterns shown below. (The picture in the manual is 70% size of the actual A4 size.)

2.3.1 A4 5% Pattern

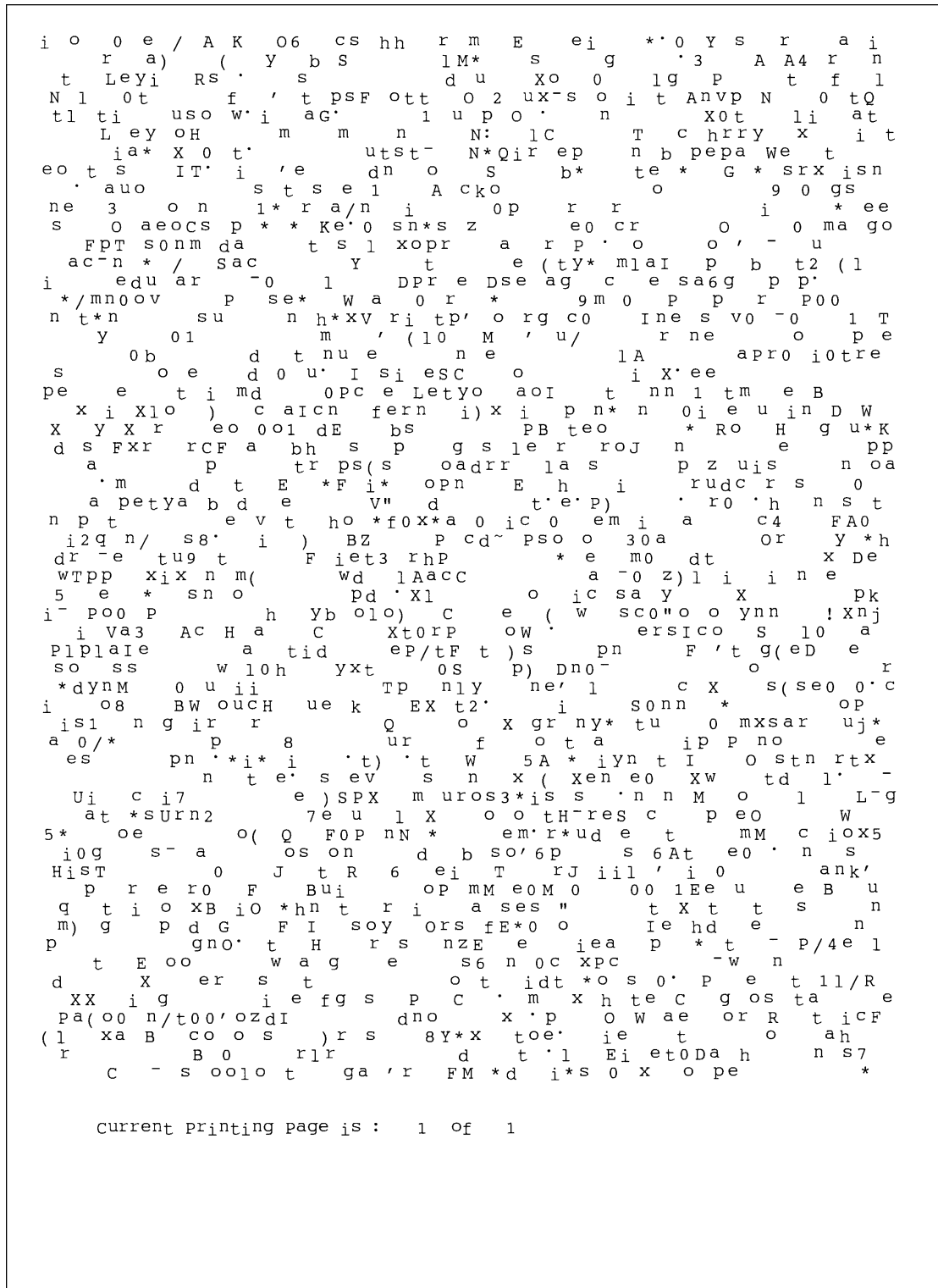

2.3.2 A4 2% Pattern

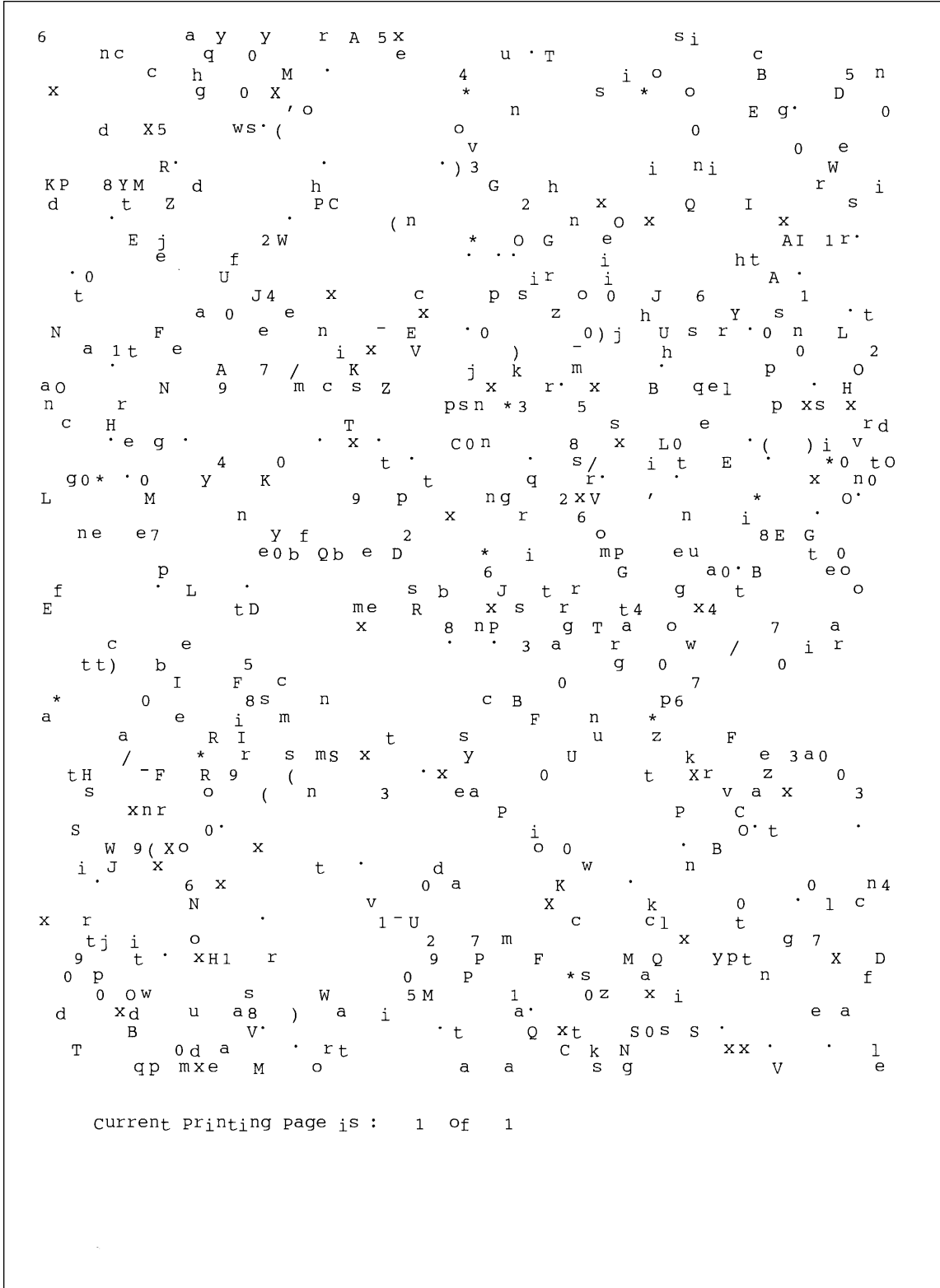

2.3.3 A4 IDC 5% Pattern

INTEROFFICE MEMORANDUM

TO: Cathy Scott
FROM: Lane Wolters
SUBJECT: The Typical Printed Page
DATE: 07/14/09

What does the typical laser printer document look like? Well, across the diverse business community it would be impossible to capture all aspects of printing style within a single page document. However, if attention is focused on the majority of printing volume, text and simple business graphics would stand out as the most prevalent output from laser printers. This

sample memo represents a reasonable example of the typical business document. This memo covers approximately 5% of a letter or A4-sized piece of paper. This number (5%) has historically been called the "average" page coverage by laser printer manufacturers. It may seem to the naked eye that there is much more than 5%, but in fact, alphanumeric characters rely on a large portion of white space for their composition.

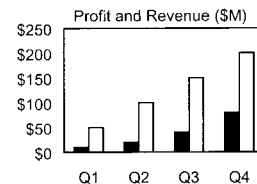

Mileage Chart

City	London	Los Angeles	New York	Tokyo
London	--	5456	3453	5975
Los Angeles	5456	--	2468	5451
New York	3453	2468	--	6736
Tokyo	5975	5451	6736	--

There are many factors that can influence the actual page coverage of a document as well as the page-yield of a toner cartridge. Testing parameters such as font size and style, internal printer settings, print environment, paper stock, sample size, job length and criteria for determining "end of life", can all influence how long a toner cartridge will last. The best competitive analysis of printer page yield should occur under similar conditions using industry standards for the variables listed above.

Memo

3. Specifications

Specifications are correct at the time of printing. Product specifications are subject to change without notice. See below for product specifications.

3.1 General Specifications

Items		Descriptions	Remarks
Major Features		Copier, Print, Scan, Fax	With ADF
Size (W*D*H)		474 X 436 X 417 mm	w/o Hand Set
Weight		13 Kg (28.8 lbs)	With Toner Cartridge
LCD		16*2 Char	
I/O Interface		USB1.1 & IEEE1284	
Power Consumption	Printing	350W	
	Sleep Mode	20W	
Power Switch		Yes	
Noise	Operating	55 dBA	
	Standby	35 dBA	
Warm Up		Less than 42 seconds	
Approval		Class B	
Device Memory		16 MB (Printer : 8M, Fax : 4M, Scan : 2M, System : 2M)	
Internal N/W Connectivity		N/A	

3.2 Print Specification

Items		Descriptions	Remarks
Print Speed		17ppm(Letter) 16pp,(A4)	5% Character Pattern
Print Method		Laser Scanning Unit + Electro Photography	
Print Language		SPL	
Power Save		Yes(5/10/15/30/45min.)	
Resolution	Normal	600 *600dpi	
	RET	No	
Toner Save		Yes	
Memory		8 MB	
FPOT	Stand by	Approx. 12 seconds	
	Power Save	Less than 54 seconds	
Printable Area		208 X 271 mm (Letter)	
		202 X 289 mm (A4)	
Toner Save		Yes	

3.3 Scan Specification

Items		Descriptions	Remarks
Halftone(Gray Scale)		256 level	
Scan Method		Color CCD	ITU-T #1 Chart
Scan Speed (seconds/scan)	ADF	Letter : 25 sec, A4 : 28 sec	Text/Mixed Mode : B/W & 300dpi. (USB)
	Platen	Letter : 25 sec, A4 : 28 sec	
	ADF	Letter : 55 sec, A4 : 60 sec	Photo Mode : Gray & 300dpi. (USB)
Platen	Letter : 55 sec, A4 : 60 sec		
Resolution	ADF	Letter : 125 sec, A4 : 130 sec	Photo Mode : Color & 300dpi.(USB)
	Platen	Letter : 125 sec, A4 : 130 sec	
Resolution	Optical	600 dpi	
	Enhanced	4800 dpi	
Halftone		256 level	
Scan Width	Width	Max.216mm (8.5")	
	Length(Adf)	Max. 356mm (14.0")	
	Length(Platen)	Max. 297mm (11.7")	
Scan-to		E-mail, Image, OCR, FAX, WEB	From SmarThru3

3.4 Copy Specification

Items		Descriptions		Remarks
Copy Quality Selection or Original Image type selection Mode	Text	600x300dpi		
	Auto	600x300dpi		
	Photo	600x600dpi for Platen / 600x300dpi for ADF		
	Other	-		
FCOT	Platen	Power Save	Approx. 54 seconds	
		Stand by	Approx. 12 seconds	
	ADF	Power Save	Approx. 54 seconds	
		Stand by	Approx. 17 seconds	
Copy Speed	Text Mixed	SDMC	16 cpm/A4, 17 cpm/LTR	
		MDMC	7 cpm/A4, 7 cpm/LTR	
	Photo	SDMC	16 cpm/A4, 17 cpm/LTR	
		MDMC	7 cpm/A4, 7 cpm/LTR	
Resolution	Scan	600*600dpi		
	Print	600*600dpi		
Zoom Range		25% to 400 % for platen, 25% to 100% for ADF		
Multi Copy		1~99		
Preset		Yes		
Contrast Control		3 level(by LED)		
Copy Mode		TEXT/MIXED/PHOTO		
Collation Copy		Yes(300dpi only)		
Auto return to default mode		Yes(after 1 minute)		
N-up copy		2-up, 4-up		ADF Only
AutoFit Copy		Yes		Platen Only
Clone		Yes		Platen Only
Poster		Yes		Platen Only

3.5 Telephone Specification

Items		Descriptions	Remarks
Handset		No	
On hook Dial		Yes	
Search		Yes (Phone Book)	by using Phone Book Button
1-Touch Dial		10EA (3*4 Numeric Key)	
Auto dial		100 locations (Using 3*4 buttons)	
TAD I/F		No	
Tone/Pulse		Selectable in Tech Mode	
Pause		Yes	
Auto Redial		Yes	
Last Number Redial		Yes	
Distinctive Ring		No	
Caller ID		No	
External Phone Interface		No	
Report & List Print out	Tx/Rx Journal	Yes	
	Confirmation	2 types available (with Image TCR, w/o image TCR)	
	Help List	No	
	Auto Dial List	Yes	
	System Data List	List all user setting	
Sound Control	Ring Volume	Yes(Off,Low,MED,HIGH)	
	Key Volume	Yes(On,Off)	
	Speaker	Yes(On,Off)	

3.6 Fax Specification

Items		Descriptions	Remarks
Compatibility		ITU-T G3	
Communication System		PSTN/PABX	
Modem Speed		33.6 Kbps	
TX Speed		Approx. 3 sec	
Compression		MH/MR/MMR/JPEG	
ECM		Yes	
Resolution	Std	203 x 98 dpi	
	Fine	203 x 196 dpi	
	S.Fine	300 x 300 dpi	
Scan Speed(ADF)	Std	Approx. 5sec/LTR (6 sec/A4)	
	Fine	Approx.7.5sec/LTR (8 sec/A4)	
	S.Fine	Approx.7.5sec/LTR (8 sec/A4)	
Rx fax duplex print out		No	
Multiple page scan speed		Approx. 7 ppm/LTR (7.5 ppm/A4)	
Receive Mode		Fax, TEL	
Memory	Capacity	4 MB (320 pages)	
	Optional Memory	No	
	Max locations to store to 1 Group Dial	99 locations	
	Fax Forward	Yes (On/Off)	
	Broadcasting	Up to 99 locations	
	Forced Memory TX	No	
	Cover page	No	
	Delayed fax	Yes	
	Memory RX	Yes	
Functions	Voice Request	No	
	TTI	Yes	
	RTI	Yes	
	Polling	No	
	Earth/Recall	No	
	Auto Reduction	Yes	
	RDC	No	
	Junk Fax barrier	Yes	
	Security Mode	Yes	
	Battery Backup	Yes (Min. 15 minutes)	Not Battery (Using Super Cap.)

3.7 Paper Handling

Items		Descriptions	Remarks
Capacity (20lbs)	Main Tray	250sheets	
	Bypass	Single Sheet	
Optional Cassette		No	
Output Capacity		150Sheets/20lb, 1Sheet/Face up	
Output Control		Face down/Face up	
Paper Size	Main Tray	CST : A4,Letter,Legal, Folio,Executive,B5	
	Bypass	Bypass : Envelope6 3/4,7 3/4, #9, #10, DL,C5,B5	
Paper Weight	Main Tray	60 ~ 90 GSM / 16 ~ 24 lb.	
	Bypass	60 ~ 150 GSM / 16 ~ 40 lb.	
Paper Path	Standard output	Bottom to Middle Front (FIFO)	
	Straight Through	Face up, Single Sheet	
Paper Size	Max	216 x 356mm(8.5"x14")	
	Min	76 x 127mm(3"x5")	
Output Stacker	Paper	Extension	
	Document	Fixed	
Input Guide	Bypass Tray	Adjustable	
	Main Tray	Universal	
	Document	Adjustable	
ADF	Paper Weight	60 ~ 105 GSM / 12.5~28lb	
	Capacity	30 sheets(80 GSM / 20lb)	
	Document Size Width	148mm - 216mm(5.8" - 8.5")	
	Document Size Length	127 mm - 356mm(5" - 14.0")	

3.8 Software

Items		Descriptions	Remarks
Compatibility	DOS	No	
	Win 3.x	No	
	Win 95	Yes	
	Win 98&WinME	Yes	
	Win NT 4.0	Yes	
	Win 2000	Yes	
	Win XP	Yes	WHQL for Printer Only
	Mac	Yes	Mac Printer Only
	Linux	No	
Driver	Printer	SPL(GDI)	
	TWAIN	Yes	
	PC-FAX	No	PC Fax is only available through PC Modem

3.9 Consumables

Items		Descriptions	Remarks
Type		Single Cartridge	
How to install		Front door open and front loading	
Toner	Life	Initial 2,000 sheets running 3,500 sheets	IDC 5% character printing
Level Sensor		No	
Toner Count		Yes	

MEMO

4. Summary of Product

This chapter describes the functions and operating principals of the main components.

4.1 Printer Components

4.1.1 Front View

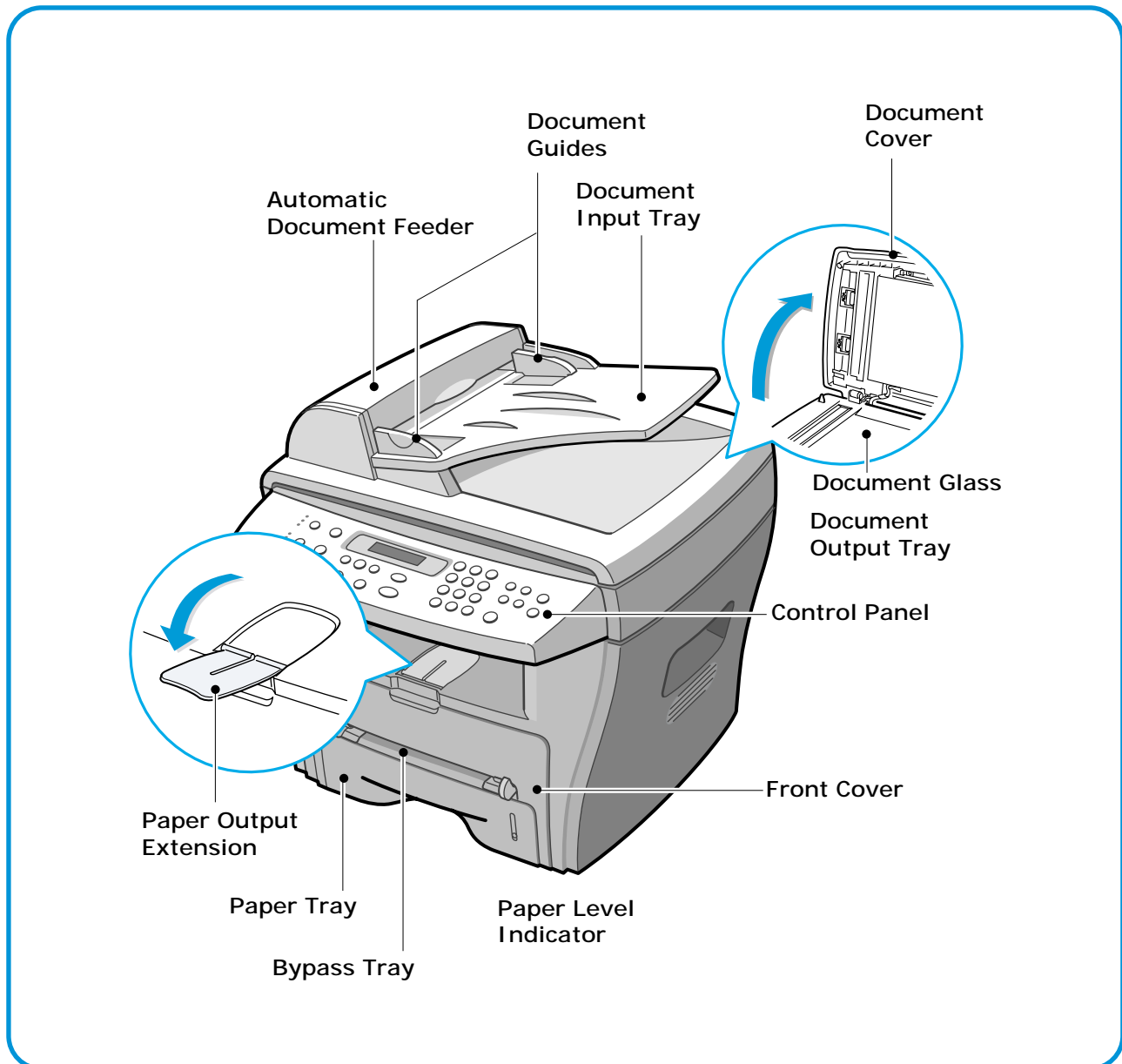



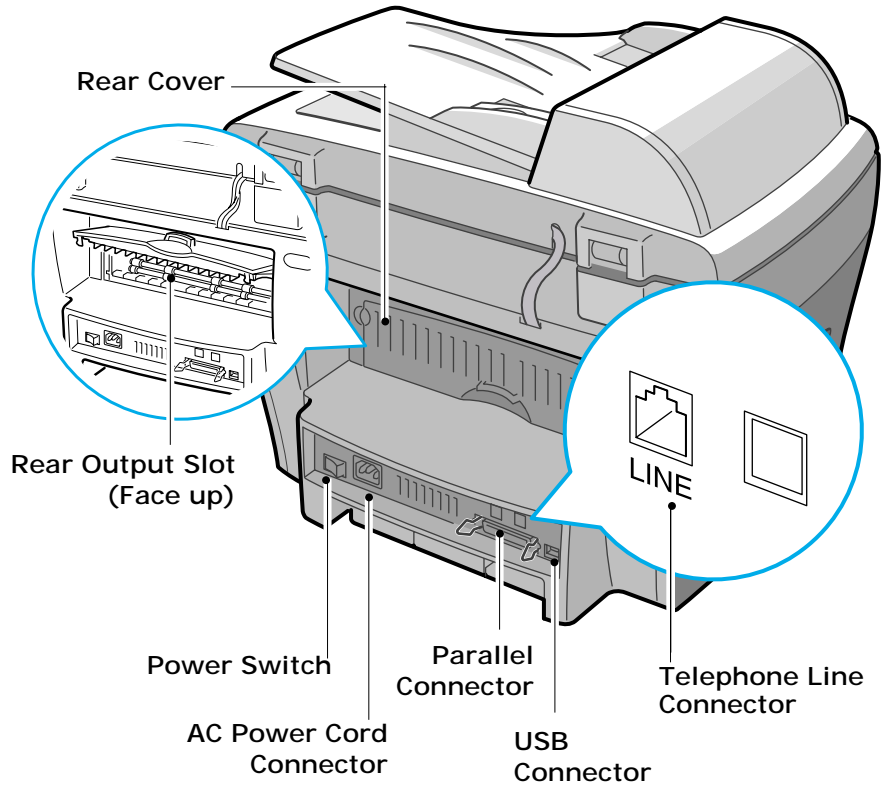



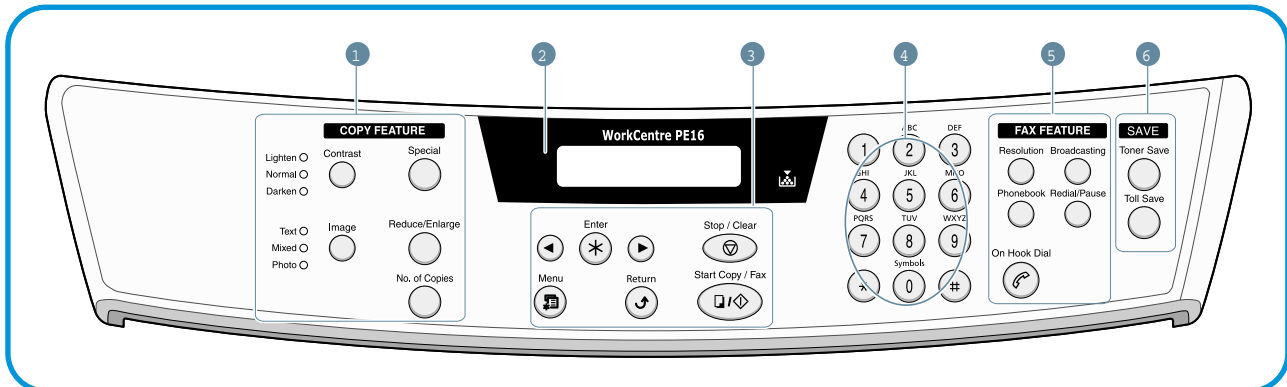













4.1.2 Rear View



4.1.3 Control Panel



1 C O P Y	 Contrast	Adjusts the brightness of the documents for the current copy job.
	 Image	Selects the document type for the current copy job.
	 Special	Allows you to use special copy features, such as Clone, Collation, Auto fit, 2-side, N-up (multiple pages on a sheet) and Poster copying.
	 Reduce/Enlarge	Makes a copy smaller or larger than the original.
	 No. of Copies	Selects the number of copies.
2		Displays the current status and prompts during an operation.
		Turns on when the toner cartridge is empty.
3		Scrolls through the options available for the selected menu item.
	 Enter	Confirms the selection on the display.
	 Menu	Enters Menu Mode and scrolls through the menus available.
	 Return	Sends you back to the upper menu level.
	 Stop / Clear	Stops an operation at any time. In Standby Mode, clears/cancels the copy options, such as the contrast, the image setting, the copy size and the number of copies.
	 Start Copy / Fax	Starts a job.

<p>4</p>		<p>Dials a number or enters alphanumeric characters.</p>
<p>5</p> <p>F</p> <p>A</p> <p>X</p>	<p>Reduce/Enlarge</p> 	<p>Adjusts the resolution of the documents for the current fax job.</p>
	<p>Broadcasting</p> 	<p>Allows you to send a fax to multiple destinations.</p>
	<p>Phonebook</p> 	<p>Allows you to store frequently-dialed fax numbers using a one or two-digit speed dial or group number for automatic dialing and edits the stored numbers.</p>
	<p>Reduce/Enlarge</p> 	<p>Allows you to print a Phonebook list. Redials the last number in Standby Mode or inserts a pause into a fax number in edit mode.</p>
	<p>On Hook Dial</p> 	<p>Engages the telephone line.</p>
<p>6</p> <p>S</p> <p>A</p> <p>V</p> <p>E</p>	<p>Toner Save</p> 	<p>Allows you to save on toner by using less toner to print a document.</p>
	<p>Toll Save</p> 	<p>Allows you to save on call costs by sending a fax at a preset toll-saving time. Using this feature, you can take advantage of lower long distance rates at night, for example.</p>

4.2 System Layout

4.2.1 Feeding section

Paper for the machine is supplied from a universal cassette or from the manual feeder, for single sheet feeding. The cassette contains a friction pad, to separate the paper and prevent multi-sheet feeding. There is a sensor to detect the presence of paper in the cassette.

- Feeding Method: Universal Cassette Type
- Feeding Standard: Center Loading
- Feeding Capacity: Cassette-250 sheets (80g/m², 20lb paper standard)
Manual 1 sheet (Paper, OHP, Envelope, etc.)
- Paper detecting sensor: Photo sensor
- Paper size sensor: None

4.2.2 Transfer Ass'y

The Transfer Ass'y consists of the PTL (pre-transfer lamp), OPC Drum, and the Transfer Roller. The PTL lights the surface of the OPC Drum, reducing the charge on the drum surface to improve transfer efficiency. The Transfer Roller transfers toner from the OPC Drum surface to the paper.

- Life span: 60,000 sheets (in 15~30°C)

4.2.3 Drive Ass'y

The Drive Ass'y is a motor driven gear unit, that drives the paper feed, the Fuser, and the distributing unit.

4.2.4 Fuser

The Fuser consists of the Heat Lamp, Heat Roller, Pressure Roller, Thermistor, and Thermostat. It melts the toner to the paper using pressure and heat to complete the printing job.

4.2.4.1 Thermostat

The thermostat is a temperature-sensing device, that cuts off the power to prevent overheating or a fire when the heat lamp or the heat coil of the heat roller becomes too hot.

4.2.4.2 Thermistor

The Thermistor detects the surface temperature of the heat roller. The information from the Thermistor provides the on/off control that maintains the selected temperature of the heat roller.

4.2.4.3 Heat Roller

The heat roller transfers the heat from the heat lamp coil to the surface of the paper. The melted toner cannot stick to the Teflon coated heat roller.

4.2.4.4 Pressure roller

The pressure roller mounted right under the heat roller is made of the silicon resin. The toner fuses onto the paper when it passes between the heat roller and the pressure roller.

4.2.4.5 Safety Relevant Facts

- Protecting device when overheating
 - 1st protecting device: H/W cuts off when an overheat condition is detected.
 - 2nd protecting device: S/W cuts off when an overheat condition is detected.
 - 3rd protecting device: Thermostat cuts off the power.
- Safety device
 - The power to the fuser is cut off when the front cover is open.
 - The overheating safety device for customer safety.
 - Maintains the surface temperature of the Fuser Cover below 80°C. A customer caution label is attached on the inside of the rear cover.

4.2.5 Scanner

Uses a photosensitive device to read an image. The Scanner consists of a CCD module, Connection board, ADF board, AFE (Analog Front End), Image Processor (located in the CPU), platen glass, and ADF.

• CCD Module Specification

1. Resolution: 600dpi/A4
2. Maximum scan wide: 8.5"
3. Color filter: Red, Green, Blue
4. Output channel: 3 channels (R, G, B)
5. Effective pixel: 5,400 pixel *3
6. Voltage: 24V & 5V
7. Pre-heating time: Maximum 30 seconds (70% of light reach to it)
8. The life span of a lamp: 30,000 hours (25°C)

• Image Processor Specification

1. Operating frequency: 66 MHz
2. Image sensor interface: 200/300/600 dpi CIS or CCD
3. Line time: Copy, FAX, Binary (Lineart, Halftone) PC Scan: 1.5ms/Line Color PC Scan (Grey, 256 Color, True Color): 4.5ms/Line
4. A/D conversion: 10bit conversion

4.2.6 LSU (Laser Scanner Unit)

The LSU is controlled by the video controller. It converts the received video data to pulsed laser light that is scanned onto the surface the OPC drum using a rotating polygon mirror. This creates the latent image on the drum surface. The OPC drum rotates at the same speed as the paper is fed. When the edge of the polygon mirror is detected, the LSU generates the /HSYNC signal. The CPU syncs the left margin of the image to this signal. After detecting the /HSYNC signal, the image data is sent to the LSU to begin transfer of the image left margin to the paper.

Each surface of the polygon mirror provides one line for scanning.

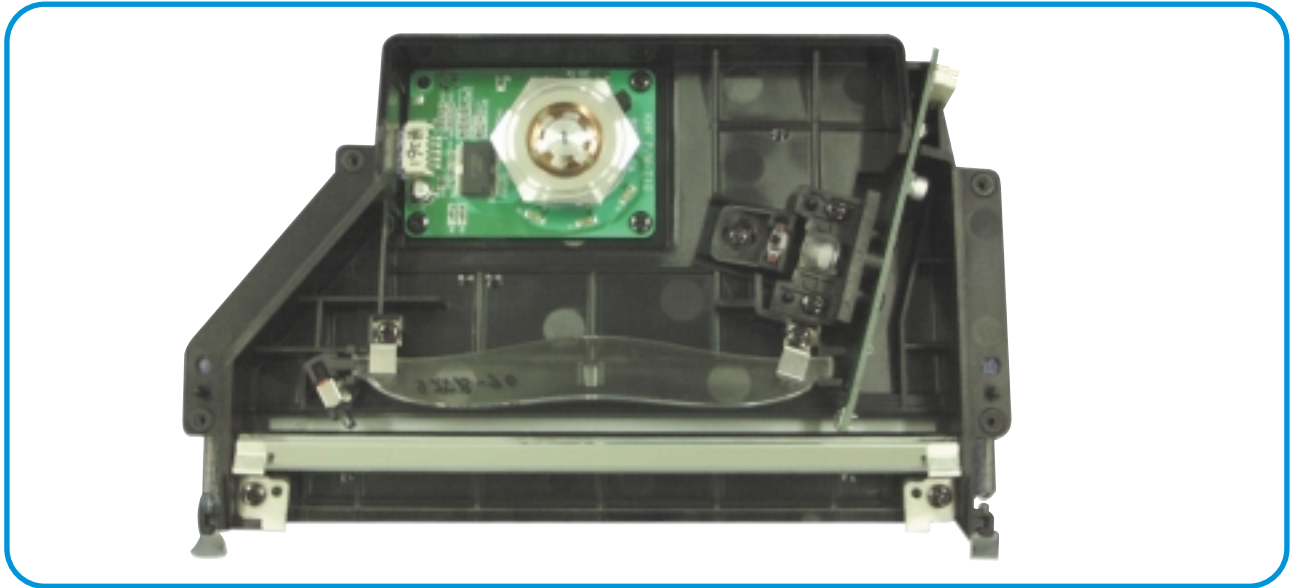

4.2.7 Toner Cartridge

The xerographic process creates a visual image from the latent image. The Toner Cartridge contains the OPC Drum, developer, and toner components in one unit. The OPC unit contains the OPC drum and charging roller. The developer unit contains toner, toner cartridge, supply roller, developing roller, and blade (Doctor blade).

- Developing Method: Non magnetic 1 element contacting method
- Toner: Non magnetic 1 element shatter type toner
- The life span of toner: 3,000 sheets (IDC Pattern/A4 standard)
- Toner remaining amount detecting sensor: None
- OPC Cleaning: Collect the toner by using electric charge + FILM OPC
- Management of excess toner: Collect the toner by using electric charge (Cleanerless Type- No excess toner)
- OPC Drum protecting Shutter: None
- Classifying device for toner cartridge: ID is classified by interruption of the frame channel.

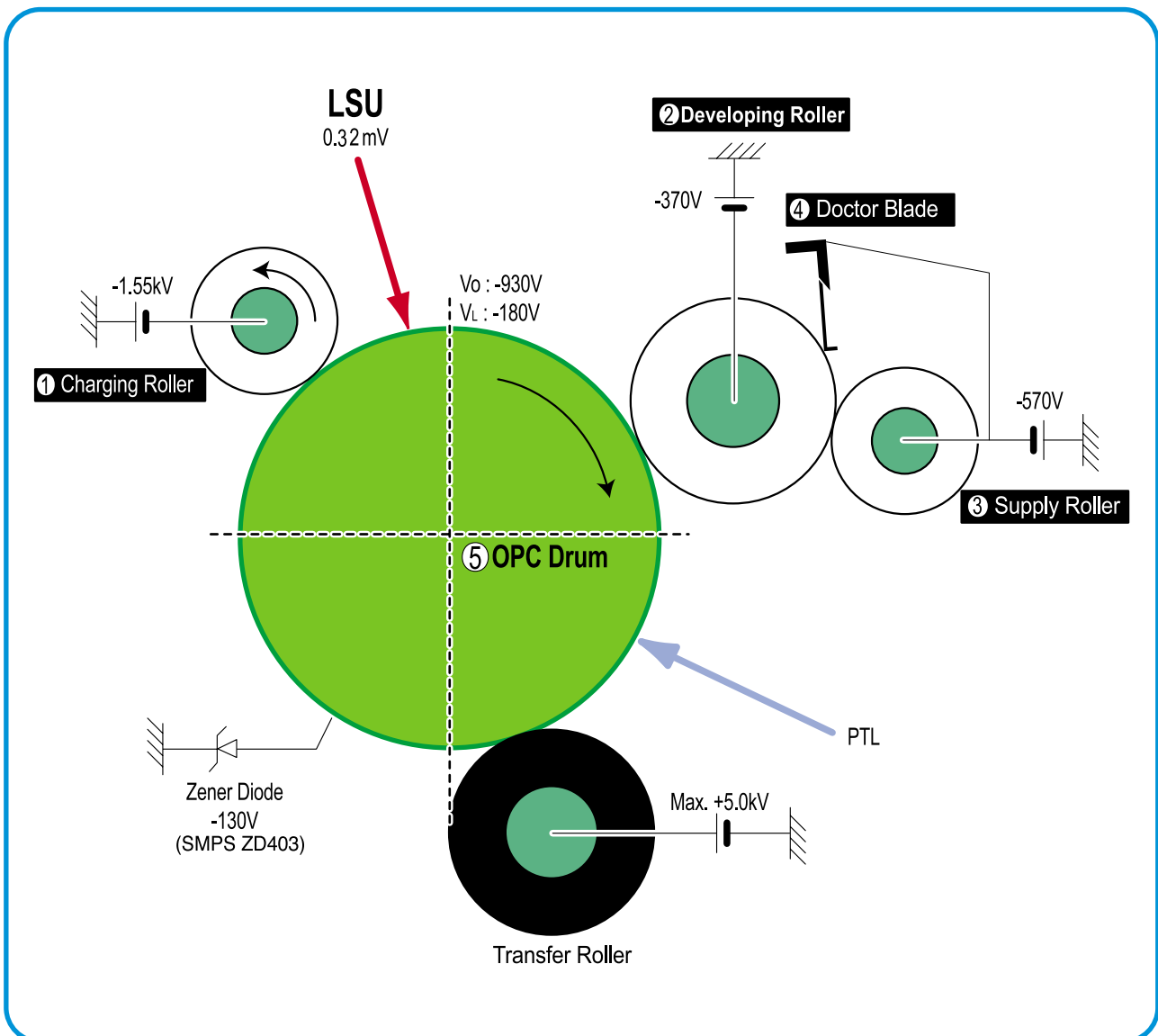

4.3 Main PBA

The Main PBA is the functional center of the product. It controls all basic machine operations including fax, scan, and printer operations, sensor detection, and power levels.

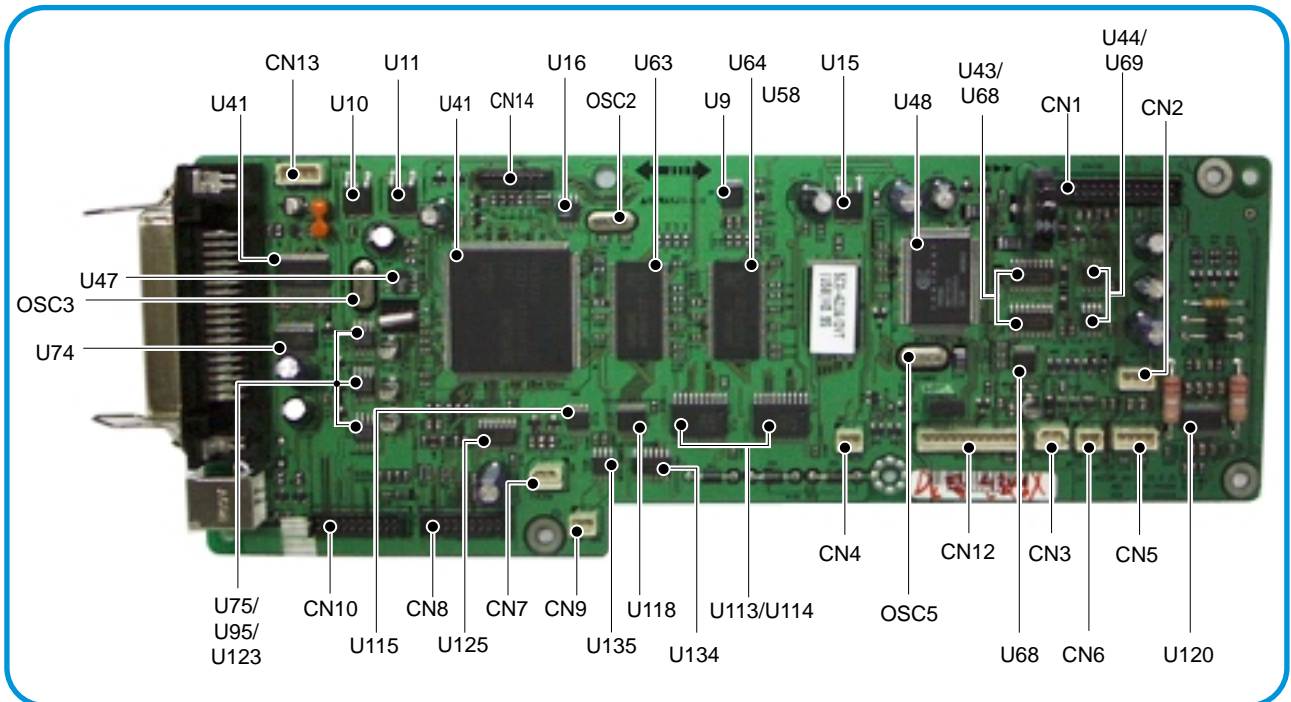
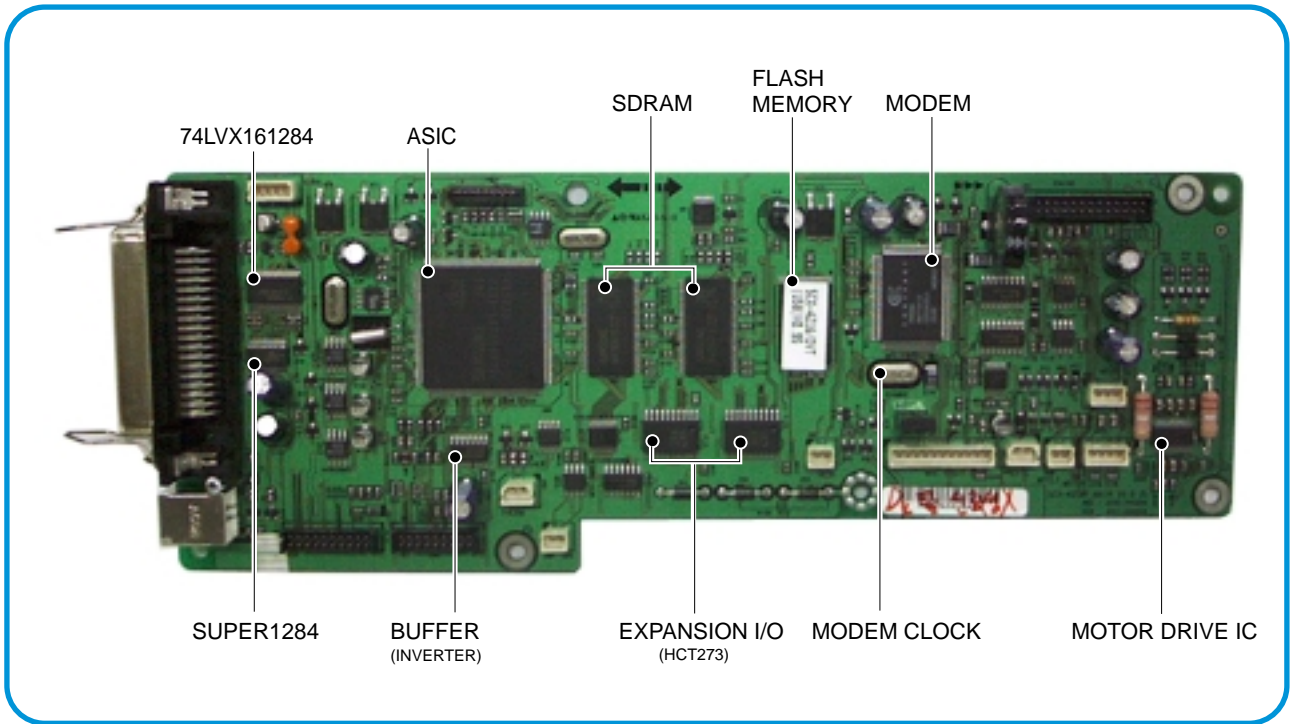

4.3.1 ASIC

Samsung's S3C46Q0X 16/32-bit RISC micro controller is designed to provide a cost-effective, low power, small die size and high performance micro-controller solution for MFP.

The S3C46Q0X is developed using ARM7TDMI core, 0.18(m CMOS standard cell, and memory cell.

•Main function block

- 1.8V internal, 3.3V external (I/O boundary) microprocessor with 4KByte Cache
- Image Processor
- On-chip clock generator with PLL
- Memory & External Bank Control
- DMA Control (5-channel)
- Interrupt Control
- 2-port USB Host /1- port USB Device (ver 1.1) Interface Control
- Parallel Port Interface Control
- UART (2 Channel)
- Synchronous Serial Interface Control
- Timer (4 Channel)
- Watch Dog Timer
- Power control: Normal, Slow, Idle, Stop and SL_IDLE mode
- A/D Converter (10-bit, 2 Channel)
- General I/O Port Control
- Print Head Control
- Carrier Motor Control
- Paper Motor Control
- Tone Generator
- RTC with calendar function
- S/W Assistant function(Rotator)

4.3.2 Flash Memory

The Flash Memory stores the system program and downloads the system program through the PC interface.

- Capacity : 0.5 M Byte
- Access Time : 70 nsec

4.3.3 SDRAM

The SDRAM is used as a buffer, system working memory area, etc. while printing.

- Access Time : 60 nsec

4.3.4 Sensor input circuit

1) Paper Empty Sensor

The Paper empty sensor (Photo Interrupter) on the engine board notifies the CPU when the cassette is empty. The empty signal to the CPU sets the D0 Bit in the CPU, which results in the CPU turning on the second LED (yellow) on the front panel.

2) MP Sensing

The MP Sensor (Photo Interrupter) on the engine board notifies the CPU if there is paper present at the MP. It reads the D0 Bit of the CPU to recognize paper in MP, and the paper is fed from MP if present.

3) Paper Feeding

When paper passes the actuator (Feed Sensor), the circuit detects the signal from the photo interrupter, sends a status signal to the CPU, and enables image data after a certain delay. If it doesn't detect the feed sensor within 1 sec. after paper is fed, paper Jam0 occurs (Red and Yellow LEDs will be turned on at the Front Panel). Developer insertion is detected using the same principle. When the developer is mounted, it operates the actuator and the signal from the photo interrupter is detected by the sensor input circuit. That process is called developer ID sensing.

4) Paper Exit Sensing

The system detects the paper exiting the unit with the exit sensor and actuator attached to the frame. The circuit detects the on/off time of the exit sensor, and the normal operation or jam information is passed to the CPU. If exit is not detected, JAM2 occurs.

5) Cover Open Sensing

The Cover Open sensor is located on the front cover. When the front cover is opened, +24V to the DC fan, solenoid, main motor, polygon motor in the LSU, and HVPS is cut off. The cover-open sensing is read from the D0 bit of CPU, and initiates developer ID sensing.

6) DC FAN / SOLENOID Driving

This function is driven by a transistor and controlled by the D6 bit of the CPU. When the bit is high, the fan is driven by turning on the transistor, and it is off when the sleep mode is selected. There are two solenoids, and they are driven by the paper pick-up and MP signal. The drive time is 300ms. The diode protects the driving transistor from the noise pulse, which is emitted when the solenoid is de-energizing.

7) Motor Driving

The motor driving circuit is formed when the Driver IC is selected. The A3977 (Motor driver IC) is used in this case. The resistance R_s value of sensing and the voltage value of the V reference can be changed by the motor driving voltage value.

4.4 SMPS & HVPS

The SMPS supplies DC power to the system. The supply receives 110V/220V input, and outputs 5V, 12V, and 24V to supply the power to the main board and ADF board.

The HVPS creates the high voltage for THV/MHV/Supply/Dev and supplies it to the developer to be used in optimizing the image display. The HVPS uses the 24V as an input and outputs the high voltage for THV/MHV/BIAS, toner, OPC cartridge, and transfer roller.

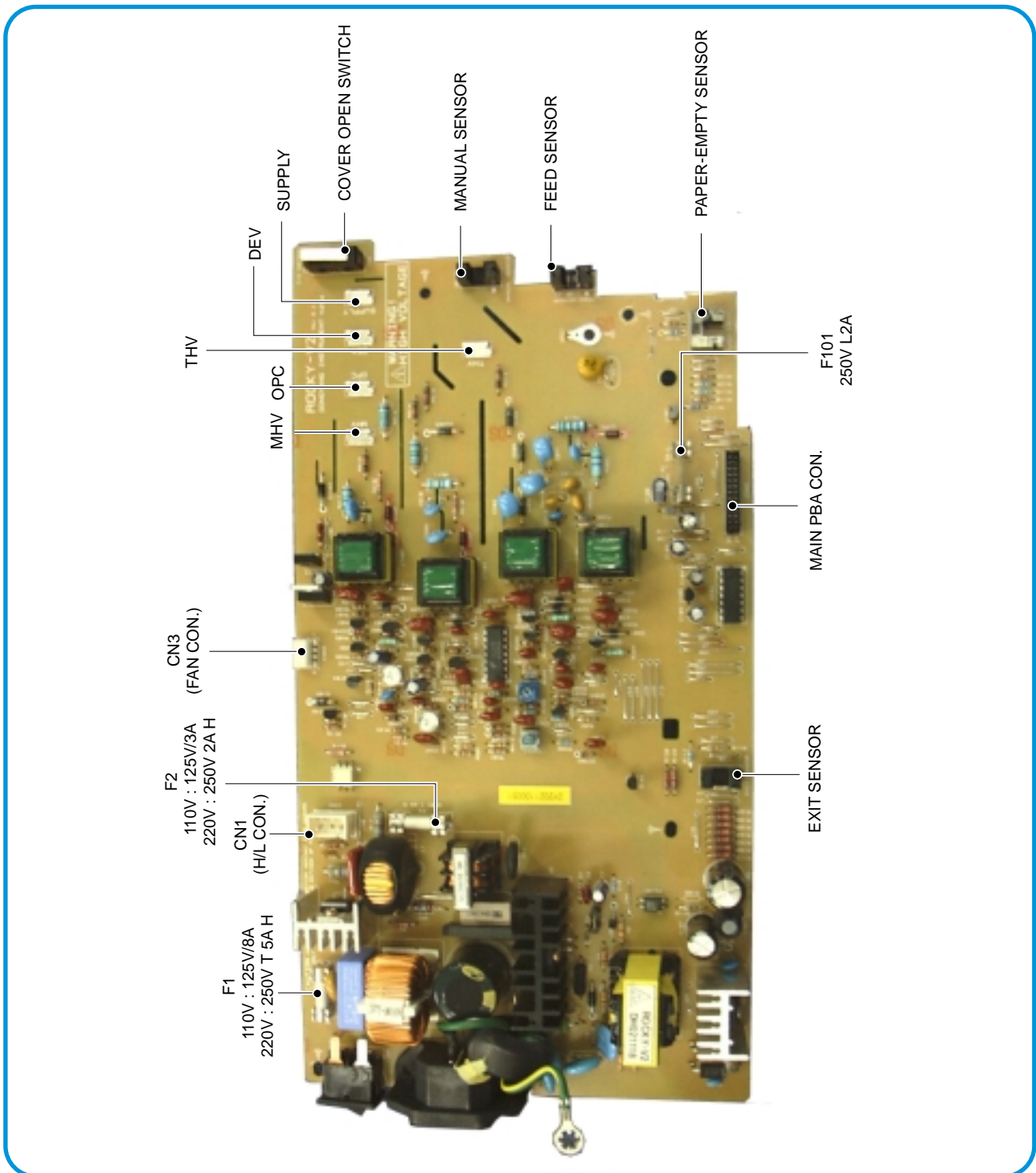

4.4.1 HVPS (High Voltage Power Supply)

1) Transfer High Voltage (THV+)

- Function : Voltage to transfer developed toner image on OPC drum to paper.
- Output voltage : +1300V DC \pm 20V
- Error : If THV (+) doesn't output, a ghost (same character is printed after one cycle (76mm) of OPC) with low density occurs due to toner on OPC drum not transferring normally to media.

2) Charge Voltage (MHV)

- Function : Charges entire surface of OPC with -900V ~ -1000V.
- Output voltage : -1550V DC \pm 50V
- Error : If MHV doesn't output, solid black print out occurs because toner on developing roller moves to OPC drum due to the surface of OPC not being charged.

3)Cleaning Voltage (THV-)

- Function : Removes excess toner on transfer roller surface by negative voltage on OPC drum to recover toners.
- Output Voltage : +300V/-150V
- Error : Toner contamination occurs at the backside of a printed-paper.

4) Developing Voltage (DEV)

- Function: Develops a toner image using a difference of electronic potential between the part of the OPC drum exposed by the LSU and the part not exposed.
- * Generally, the electronic potential of exposed OPC is -180V and exposed developer is -350V when printing, so toner with minus (-) is developed on an exposed part.
- Output voltage: -430V DC \pm 20V
- Error: 1. If DEV is GND, density is reduced significantly.
2. If DEV is floating due to poor ground contact, etc., density is increased significantly.

5) Supply Voltage (SUP)

- Function: Voltage to supply toner to developing roller.
- Output voltage: : -630V DC \pm 50V (Use ZENER, DEV Gear)
- Error: 1. If SUP is GND, a density is reduced significantly.
2. If SUP is floating due to poor ground contact, etc., density drops to almost non-existent levels.

4.4.2 SMPS (Switching Mode Power Supply)

This is the power source for the whole system. It is an independent module, so it can be used for common use. It is mounted at the bottom of the set.

The module contains the SMPS, which supplies the DC power for driving the system, and the AC heater control, which supplies the power to the Fuser. The SMPS has four outputs (+5V, +12V, +12V, and +24Vs).

There are three kinds of power, 120V exclusive (America), 220V exclusive (Europe), and 220V for China (nations with unstable power supply).

1) AC Input

- Input rated voltage : AC 220V ~ 240V AC 100~127V
- Input voltage range : AC 198V ~ 264V AC 90V ~ 135V
- Rated frequency : 50/60 Hz
- Frequency range : 47 ~ 63 Hz
- Input voltage : Under 4.0 Arms/2.0 Arms
(The state when lamp is off or rated voltage is input/output)

2) Rated Power Output

NO	Item	CH1	CH2	CH3	CH4
1	Channel name	+5V	+12V	+24.0V	+24.0VS
2	CONNECTOR PIN	CON 2 3.3V PIN: 3, 4 GND PIN: 5, 6	CON2 5V PIN : 8 GND PIN: 7	CON2 24V PIN: 13, 16 GND : 9, 10	CON2 24V PIN: 11, 12 GND : 18
3	Rated outputting voltage	+5V ± 5% (4.75 ~ 5.25V)	+12V ± 5% (11.4 ~ 12.6V)	+24V ± 10% (21.6 ~ 26.4V)	+24V ± 10% (21.6 ~ 26.4V)
4	Rated outputting current	1.0 A	0.05A	1.0 A	0.5
5	Ripple noise voltage	150mVp-p	150mVp-p	500mVp-p	500mVp-p
6	Maximum output	7.5W	0.6W	36.0W	24.0W

3) Consumption Power

NO	Item	CH1 (+5V)	CH2 (+12V)	CH3 (+24V)	CH3 (+24VS)	System
1	Stand-By	1.0 A	0.05A	1.0 A	0.5 A	AVG : 95 Wh
2	PRINTING	1.5 A	0.5A	1.5 A	1.0 A	AVG : 350 Wh
3	Sleep-Mode	0.3A	0.0A	0.0A	0.06A	AVG : 20 Wh

4) Length of Power Cord : 1830 ± 50mm

5) Power Switch : Use

6) Feature

- Insulating resistance : over 50M Ω (at 500 VDC)
- Insulating revisiting pressure : Must be no problem within 1 min. (at 1500 Vz_c, 10 mA)
- Leaking voltage : under 3.5mA
- Running voltage : under 40 A peak (at 25°C, Cold start) Under 60 A peak (in other conditions)
- Rising Time : Within 2 Sec.
- Falling Time : Over 20 mSec.
- Surge : Ring Wave 6 KV-500 A (Normal, Common)

7) Environment Condition

- Operating temperature range : 0°C ~ 40°C
- Maintaining temperature range : -25°C ~ 85°C
- Maintaining humid range : 30% ~ 90% RH
- Operating atmospheric pressure range : 1

8) EMI Requirement : CISPR ,FCC, CE, MIC, C-Tick,**9) Safety Requirement**

- IEC950, C-UL, TUV, Semko, iK, CB, CCC, EPA,

4.4.3 Fuser AC Power Control

Fuser (HEAT LAMP) gets heat from AC power. The AC power controls the switch with the Triac, a semiconductor switch. The 'On/Off control' is operated when the gate of the Triac is turned On/Off by Photo Triac (insulating part).

In the other words, the AC control is a passive circuit, so it turns the heater On/Off using a signal from the Engine Control.

When the 'HEATER ON' signal is turned on at Engine Control, the LED of PC1 (Photo Triac) turns on. The blinking light, the Triac part (light receiving part) takes the voltage, and the voltage is supplied to the gate of Triac and flows into the Triac. As a result, the AC current flows in the heat lamp, supplying heat to the heat roller.

On the other hand, when the signal is off, the PC1 is off, the voltage is cut off at the gate of Triac, the Triac remains off, and the heat lamp is turned off.

1) Triac (THY1) feature

- 12A,600V SWITCHING

2) Phototriac Coupler (PC3)

- Turn On If Current : 15mA ~ 50mA(Design: 16mA)
- High Repetitive Peak Off State Voltage : Min 600V

4.5 Engine F/W

4.5.1 Feeding

If feeding from the cassette, the pickup roller drive is controlled by the solenoid. The solenoid is switched on and off by control signals from either the general output port or the external output port. If feeding from the manual feeder, paper presence is sensed by the manual sensor, and paper is fed by driving the main motor, insert the paper in front of the feed sensor. While paper moves, occurrence of jam is judged as below. (Refer to 6.2 Clearing Paper Jams])

4.5.1.1 Jam 0

- Paper is picked up, but cannot enter path due to paper feed failure.
- Paper is picked up and enters path, but it cannot reach the feed sensor in specified time due to slip, etc.
- After pick up, if the feed sensor is not on, pick up is repeated. After repeating pick up, if the feed sensor is still not on after the specified time, Jam 0 is set.
 - Jam 0 status indicates that the leading edge of the paper doesn't pass the feed sensor.
- Even though the paper reaches the feed sensor, the feed sensor doesn't turn on.
 - It is a status that the leading edge of the paper already passes the feed sensor.

4.5.1.2 Jam 1

- After the leading edge of the paper passes the feed sensor, the trailing edge of the paper does not pass the feed sensor after the specified time. (The feed sensor cannot be Off)
- After the leading edge of the paper passes the feed sensor, the paper does not pass the exit sensor after the specified time. (The exit sensor cannot be On)
 - The paper remains between the feed sensor and the exit sensor.

4.5.1.3 Jam 2

- After the trailing edge of the paper passes the feed sensor, the paper does not pass the exit sensor after the specified time.

4.5.2 Drive

By gearing, the main motor drives the rollers such as feeding roller, developing roller, fuser roller, and distributing roller. The step motor is controlled for the sections, acceleration section and fixed speed section. In the initial stage of the motor run, appoint the acceleration section to prevent the isolation of the motor. It is controlled by the A3977 motor driver IC. The step signal and the enable signal are sent to make the phase for driving the motor in CPU.

4.5.3 Transfer

The charging voltage, developing voltage and the transfer voltage are controlled by PWM (Pulse Width Modulation). Each output voltage is changeable due to the PWM duty. The transfer voltage admitted when the paper passes the transfer roller is decided by environment recognition. The resistance value of the transfer roller is changed due to the surrounding environment or the environment of the set, and the voltage value, which changes due to the environments, is changed through AD converter. The voltage value for impressing to the transfer roller is decided by the changed value.

4.5.4 Fusing

The temperature of the heat roller's surface is changed due to the resistance value of the thermistor. By converting the voltage value to a digital value, through the AD converter, the temperature is selected. The AC power is controlled by comparing the target temperature to the value from the thermistor. If the value from the thermistor is out of the controlling range while controlling the fusing, the error stated in the table occurs.

4.5.4.1 Error Type

Error	Description
Open heat error	When warming up, it has been lower than 68 °C over 25 sec
Lower heat error	<ul style="list-style-type: none"> • Standby: It has been lower than 100°C over 25 sec • Printing: <ul style="list-style-type: none"> - 2 consecutive pages: it has been lower than 145°C over 5 sec - 3 consecutive page; it has been 40°C lower than the fixed fusing temperature over 4 seconds.
Over heat error	It has been higher than 220°C over 3 seconds

4.5.5 LSU

The LSU is consists of the LD (Laser Diode) and the polygon motor control. When the printing signal occurs, it turns on the LD and drives the polygon motor. When the light sensor detects the beam, Hsync occurs. When the polygon motor reaches normal speed, LReady occurs. If the two conditions are satisfied, the status bit of the LSU controller register becomes 1, the LSU is ready. If the two conditions are not satisfied, the error shown in the table below occurs.

Error	Description
Polygon motor error	When the polygon motor does not reach normal speed
Hsync error	The polygon motor speed is normal, but the Hsync signal is not created.

4.6 LIU PBA

LIU board is a Line interface unit, and it is a circuit for interfacing a telephone line with a modem. The circuit consists of matching transfer to conform to impedance of a receiving telephone line and a circuit to conform to impedance of a modem.

Also, there is a ring detect circuit to detect a ring signal from a switchboard and a surge absorber to protect it from an external high voltage supply applied to a line input unit.

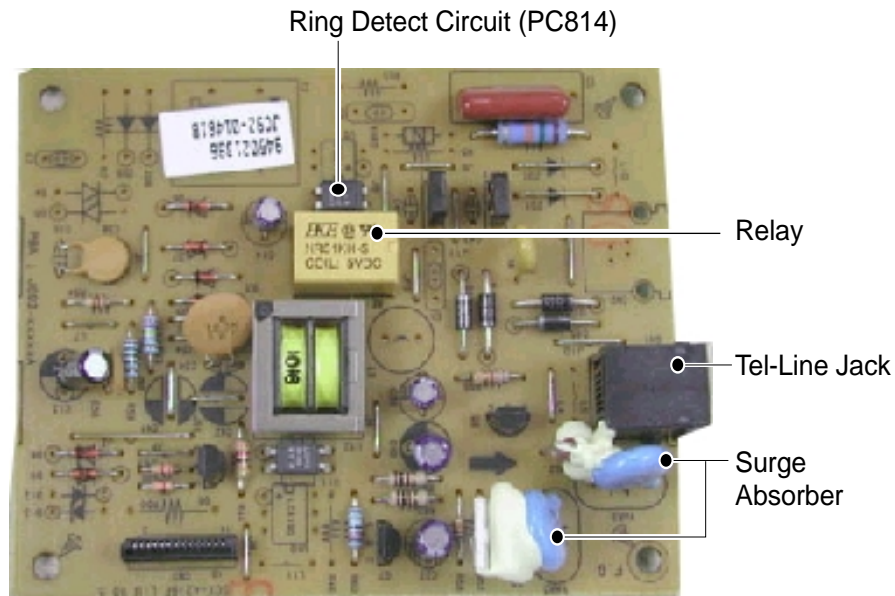

4.7 OPE PBA

OPE board consists of various function keys and LCDs to display key operations. MICOM creates a circuit using HT48R50 MICOM of HOLTEC CO. and applies LED and LCD. The communication method with the Main Board CPU is a UART, and related signals are /Reset, TXD, and RXD.

5. Disassembly and Reassembly

5.1 General Precautions on Disassembly

When you disassemble and reassemble components, you must use extreme caution. The close proximity of cables to moving parts makes proper routing essential.

If components are removed, any cables disturbed by the procedure must be restored as close as possible to their original positions. Before removing any component from the machine, note the cable routing that will be affected.

Whenever servicing the machine, you must perform the following:

1. Check to verify that documents are not stored in memory.
2. Be sure to remove the toner cartridge before you disassemble parts.
3. Unplug the power cord.
4. Use a flat and clean surface.
5. Replace only with authorized components.
6. Do not force plastic-material components.
7. Make sure all components are in their proper position.
8. Observe ESD precautions when handling sensitive electronic components.

Releasing Plastic Latches

Many of the parts are held in place with plastic latches. The latches break easily; release them carefully.

To remove such parts, press the hook end of the latch away from the part to which it is latched.

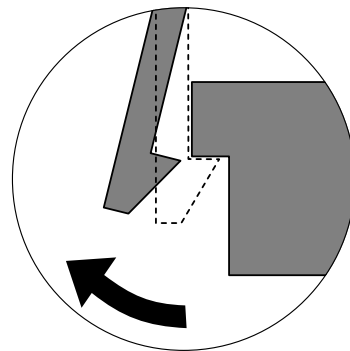

5.2 Rear Cover

1. Remove the four screws securing the Rear Cover.

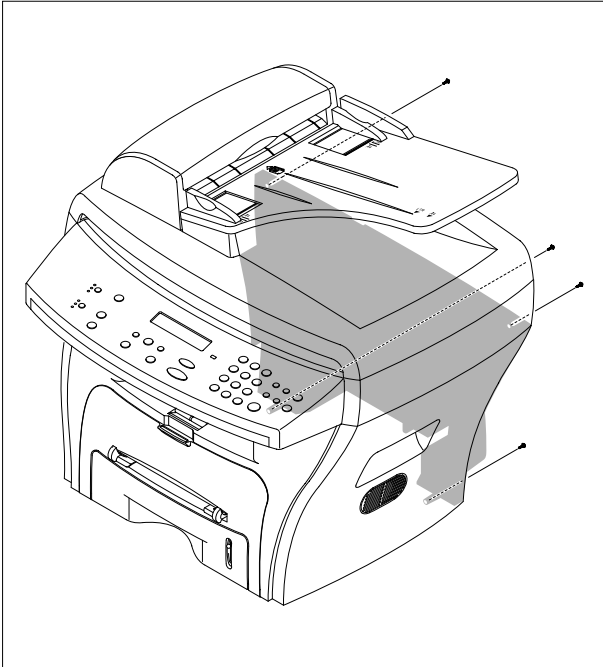

3. Unlatch the (Cover Face Up) securing the Rear cover, as shown below. Then lift the (Cover Face Up) out.

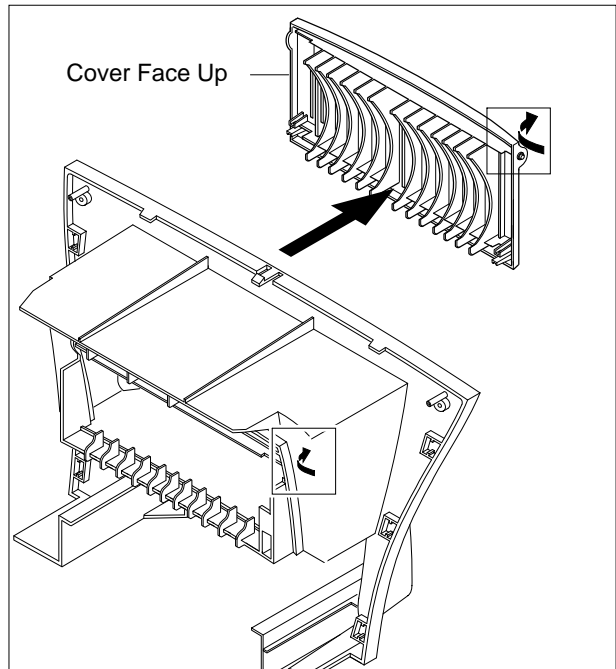

2. Remove the Rear Cover from the Frame Ass'y and Scanner Ass'y.

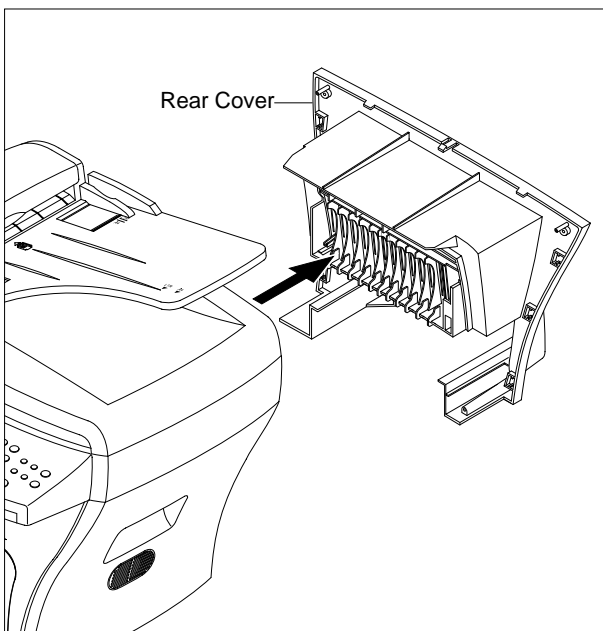

5.3 Side Cover (LH, RH)

1. Before you remove the Side Cover (LH, RH), you should remove:

- Rear Cover (see page 5-2)

2. Unplug the Speaker Harness, as shown below.

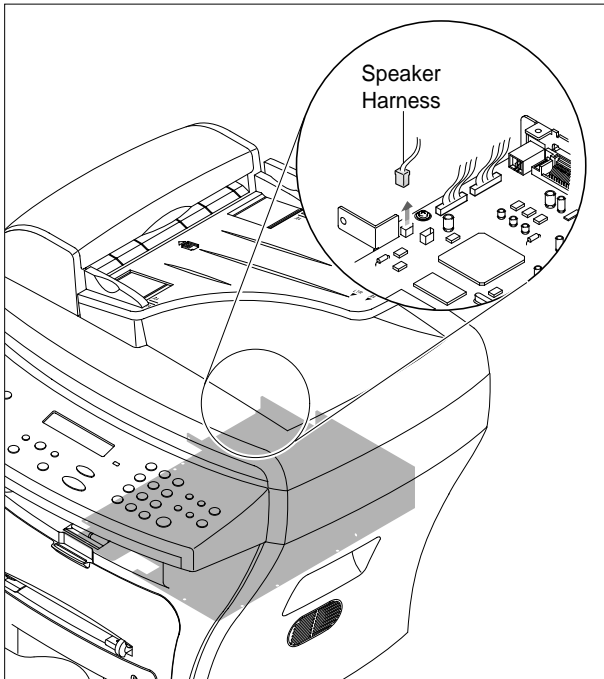

3. Pull down and back on the LH and RH Side Covers and lift them out in the direction of the arrows.

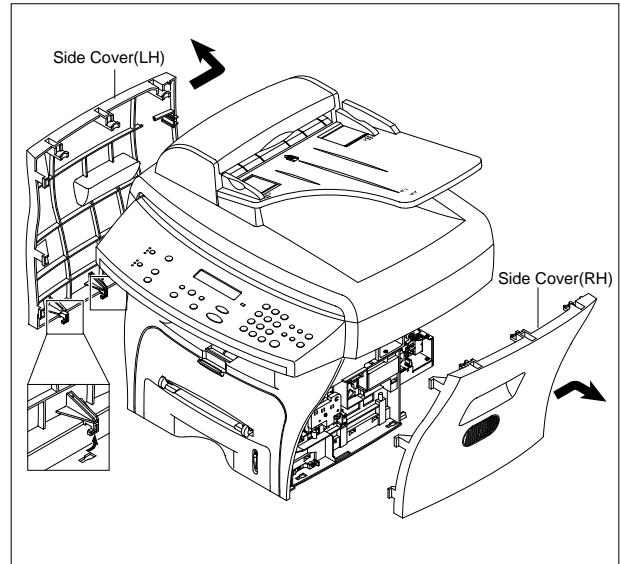

5.4 Front Cover

1. Take out the Cassette.

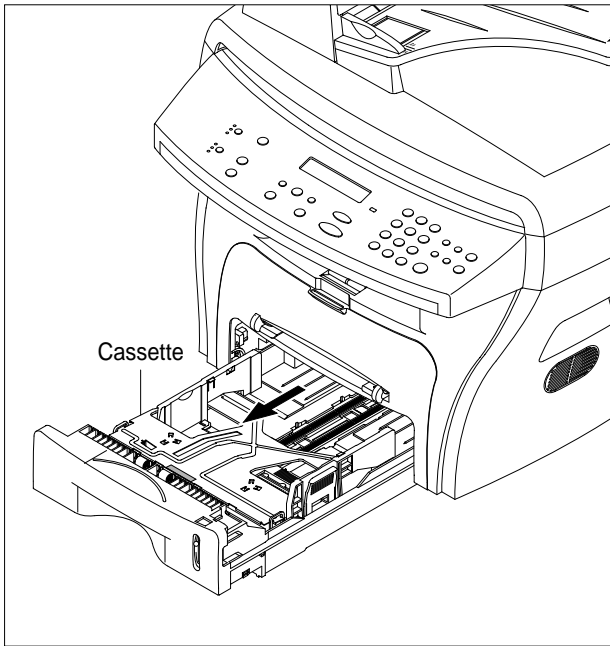

3. Unlatch the Front Cover securing the Frame Ass'y. Then remove the Front Cover, as shown below.

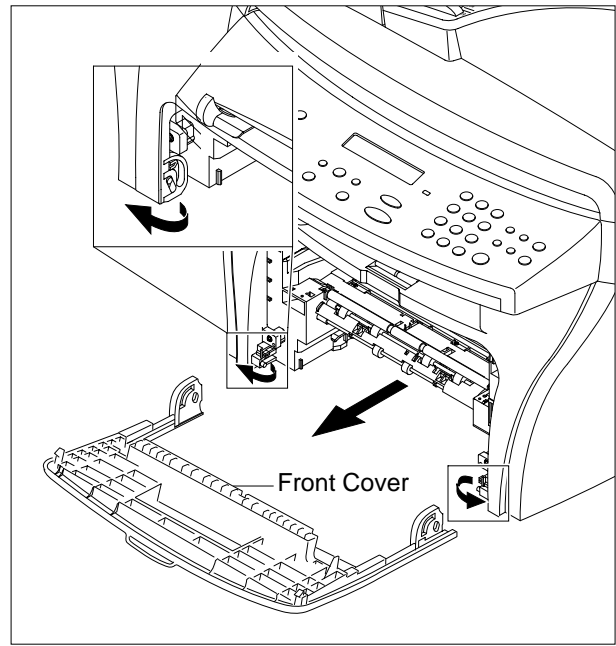

2. Open the Front Cover.

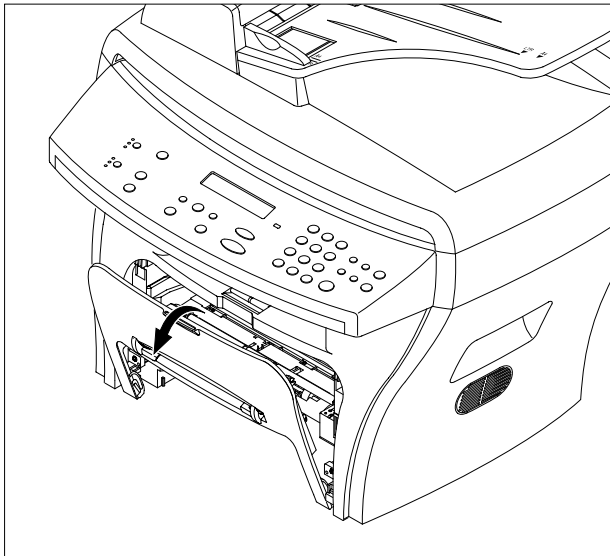

5.5 Scanner Ass'y

1. Before you remove the Scanner Ass'y, you should remove:

- Rear Cover (see page 5-2)
- Side Cover (LH, RH) (see page 5-3)

2. Remove the two screws securing the Scanner Ass'y, as shown below.

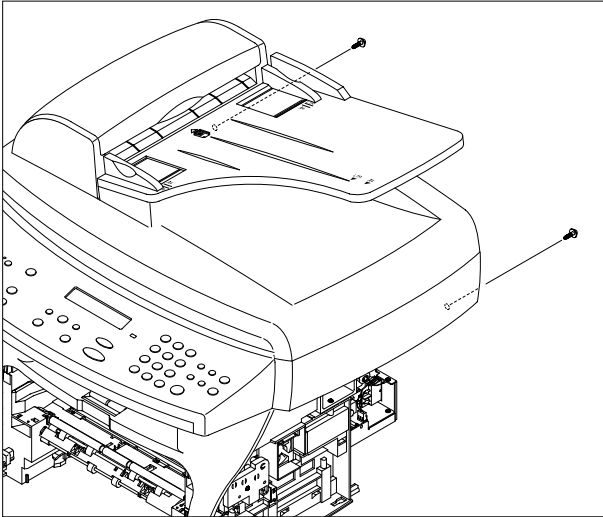

4. Pull up the Scanner Ass'y, as shown below.

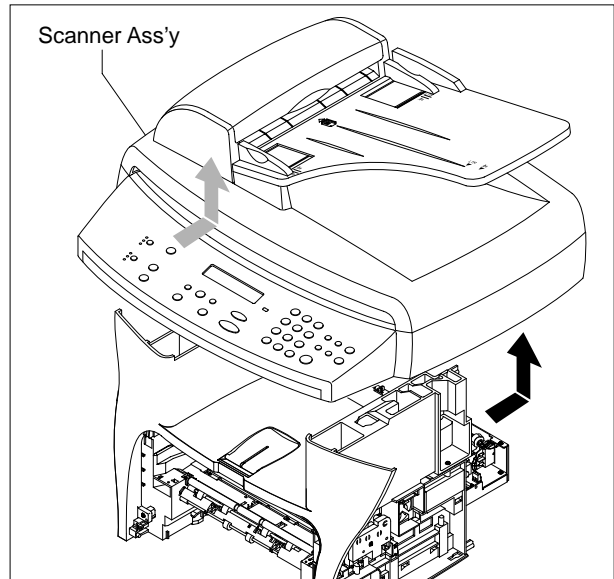

3. Unplug the four connectors from the Connector PBA , as shown below, and remove the ground wire.

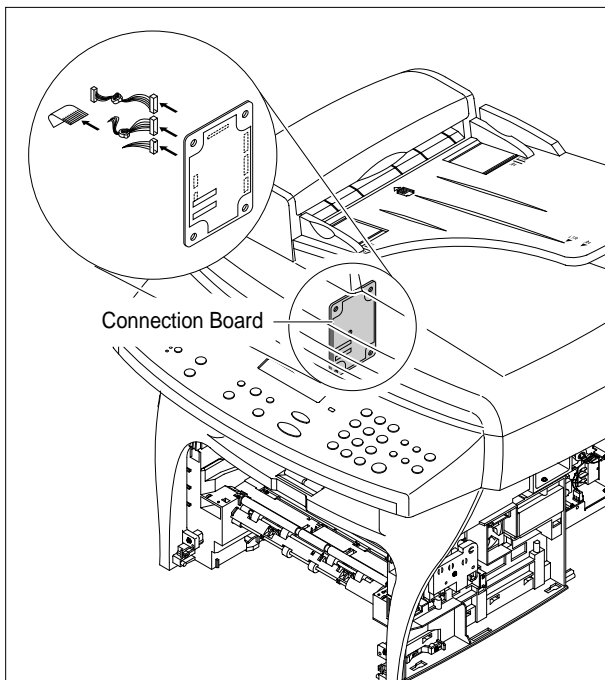

5. Disconnect the cover wiring harness then pull the Platen Cover upward and remove it.

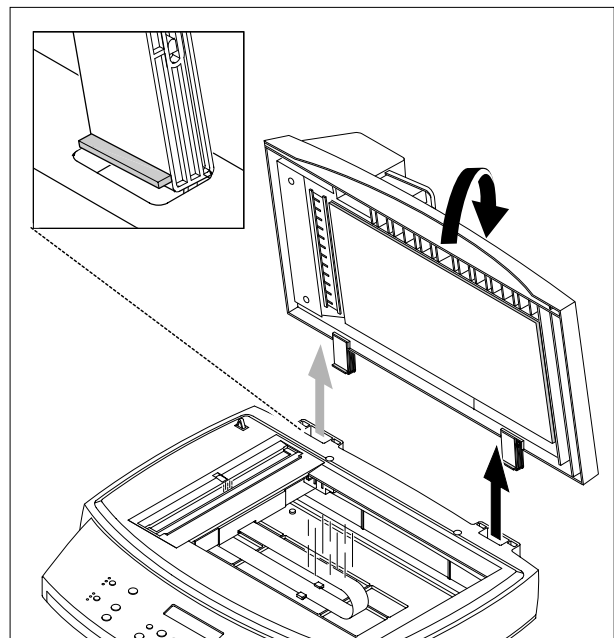

6. Remove the three screws securing the Scan Ass'y.

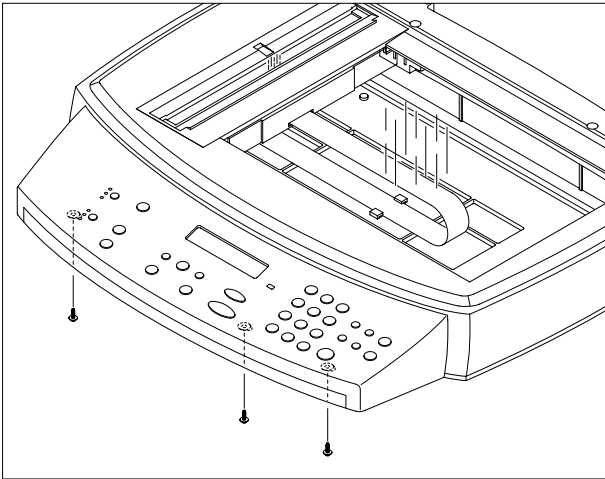

8. Remove the four screws securing the Scan Upper.

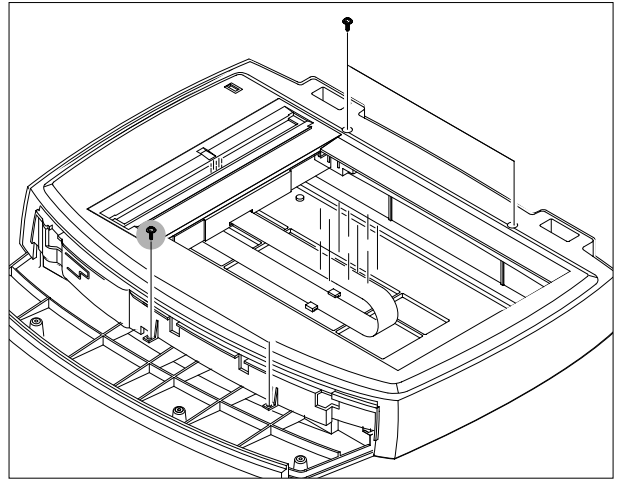

7. Lift the OPE Unit out. Then unplug the two connectors from the OPE Unit and remove it.

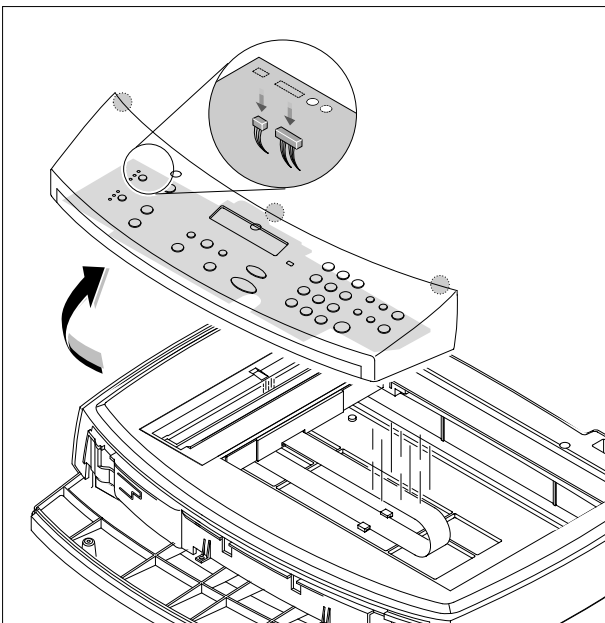

9. Unlatch the Scan Upper securing the Scan Ass'y. Then pull the Scan Upper upward and remove it.

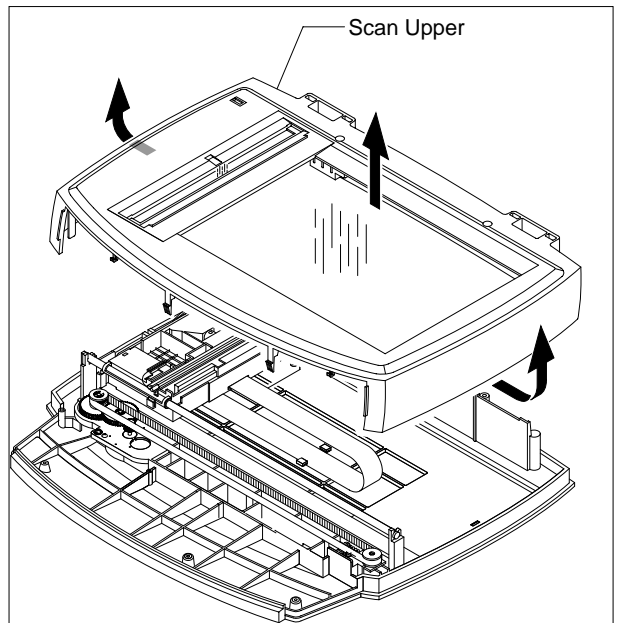

10. Disconnect the CCD Ass'y end of the CCD Cable.

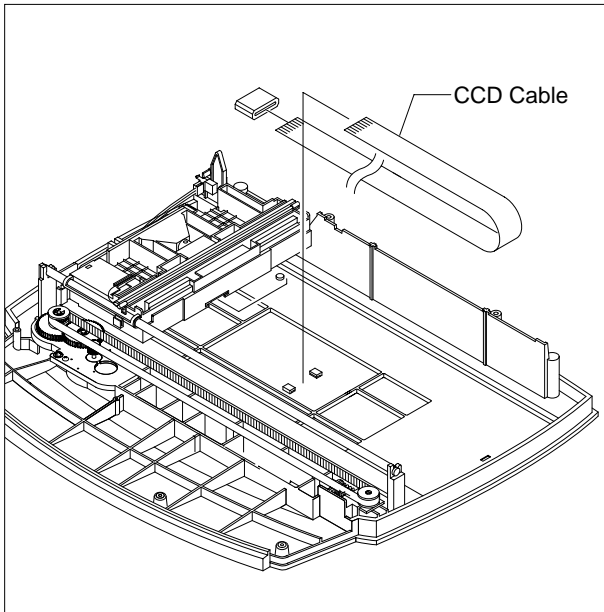

12. Pull up the CCD Shaft and take out the Scanner Module.

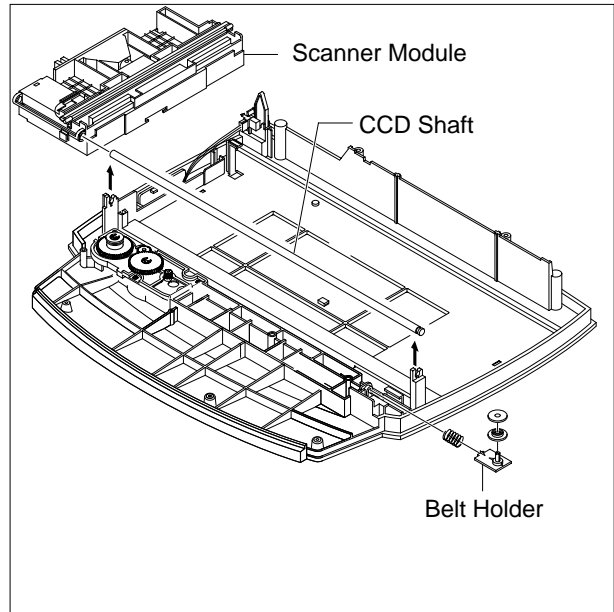

11. Push the Belt Holder and take out the Belt, as shown below.

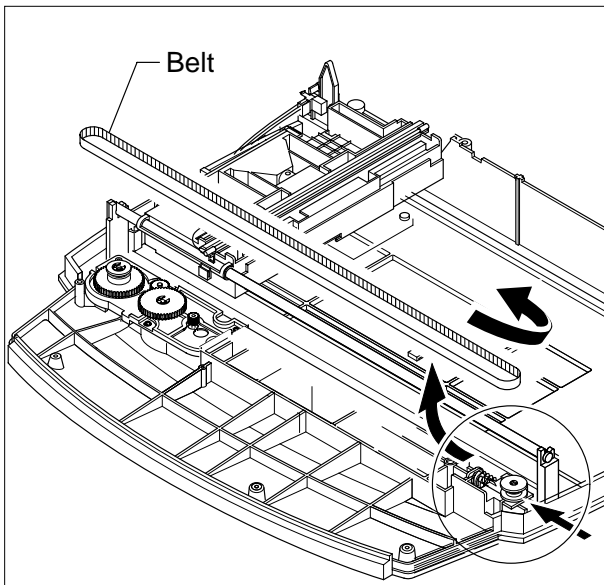

14. Remove the two screws and take out the Motor Bracket.

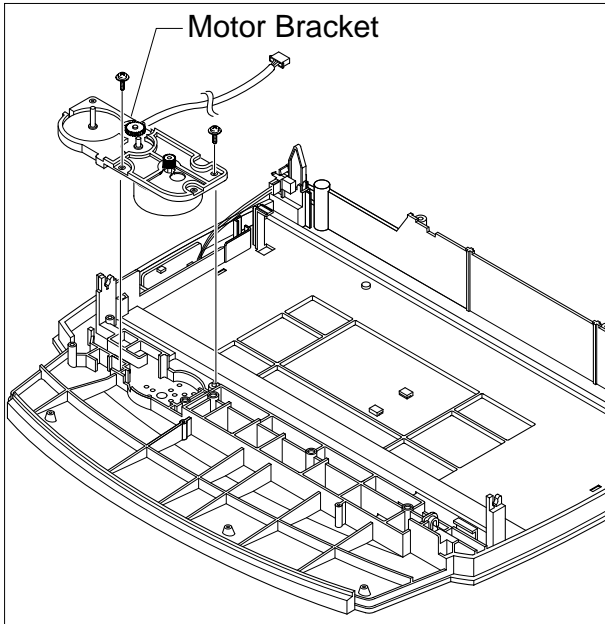

16. Unlatch the Open Sensor and remove it, as shown below.

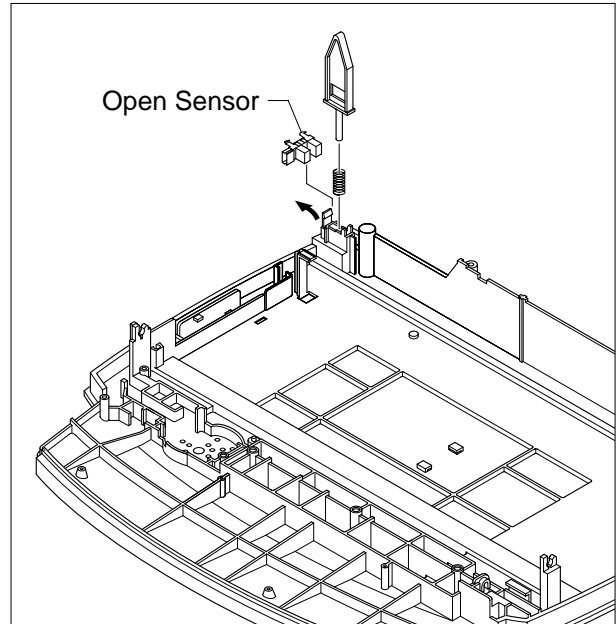

15. Unplug the one connector from the Open Sensor Ass'y.

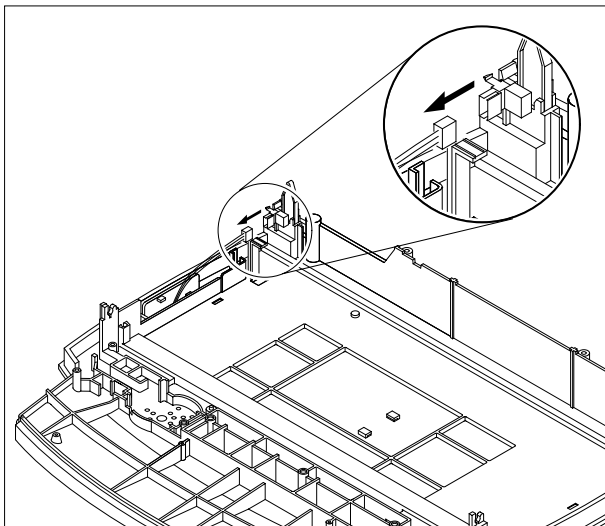

5.6 ADF Motor Ass'y

1. Before you remove the ADF Motor Ass'y, you should remove:
 - Four screws securing the Tray and remove the Tray
 - Two screws securing the ADF Ass'y
 - Wiring harness from cover
2. Remove the ADF Ass'y.

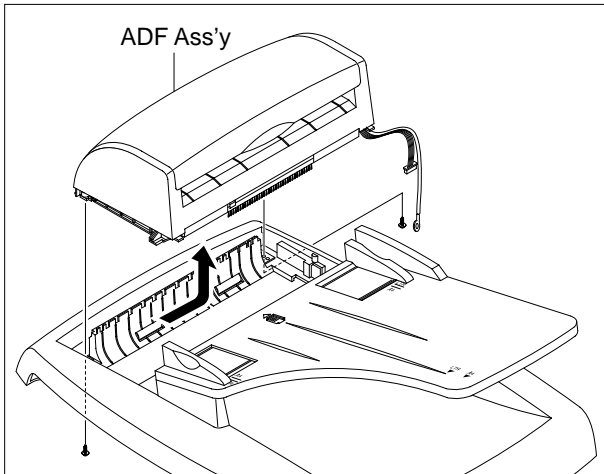

3. Remove the Open Cover, as shown below.

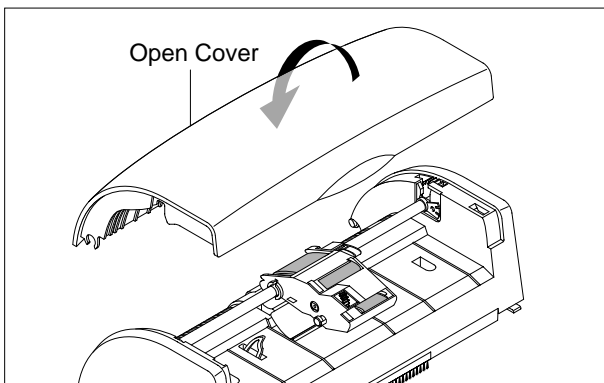

4. Pull the White Bush, then rotate it until it reaches the slot, as shown below. Then lift the Pick-Up Ass'y out.

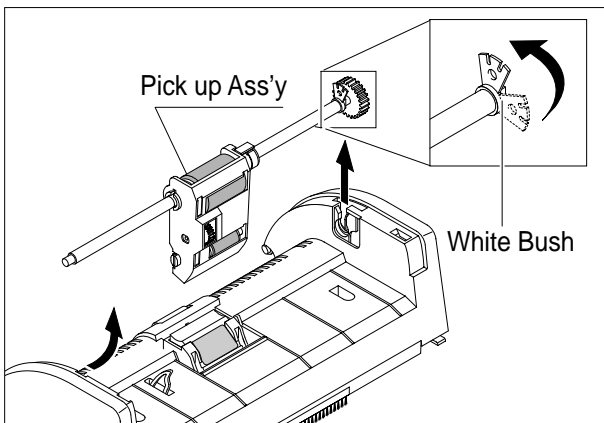

5. Remove the two screws securing the Upper Cover and remove it, as shown below.

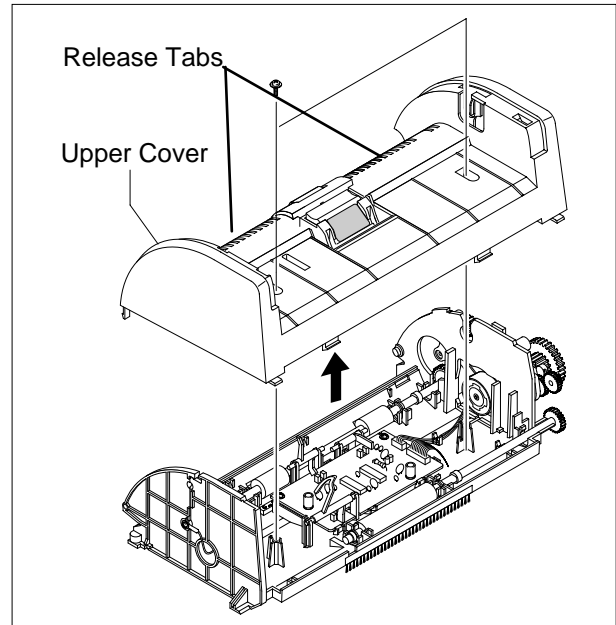

6. Unplug the one connector and remove four screws and one ground screw securing the ADF Motor Ass'y. Then take out the ADF Motor Ass'y.

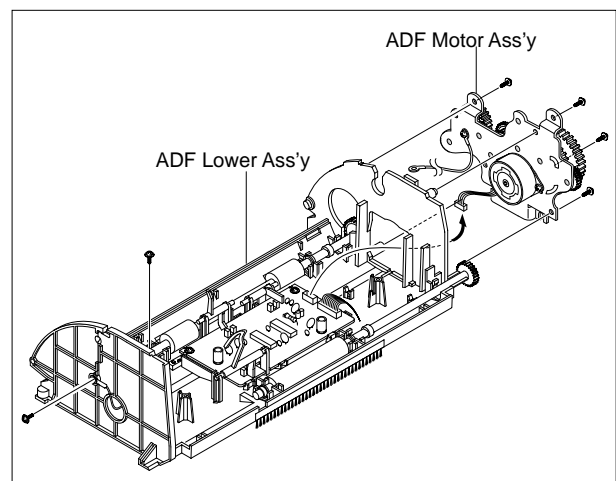

5.7 OPE Unit

1. Remove the seven screws securing the OPE PBA to the OPE Cover.

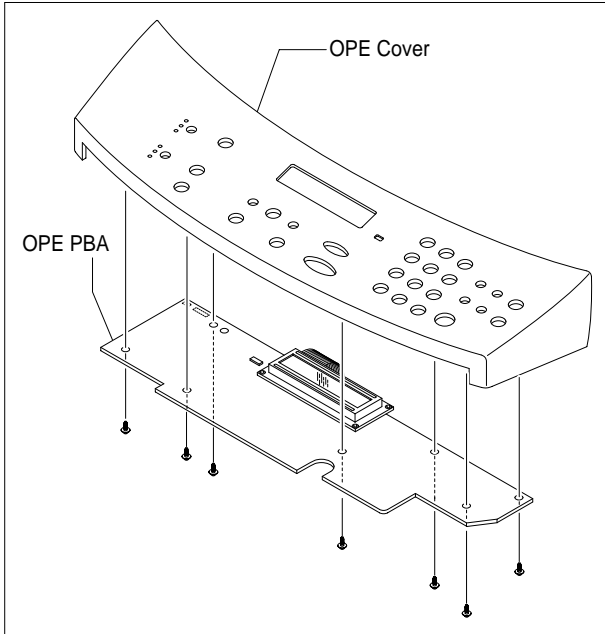

3. Remove the Key Pad from the OPE Cover.

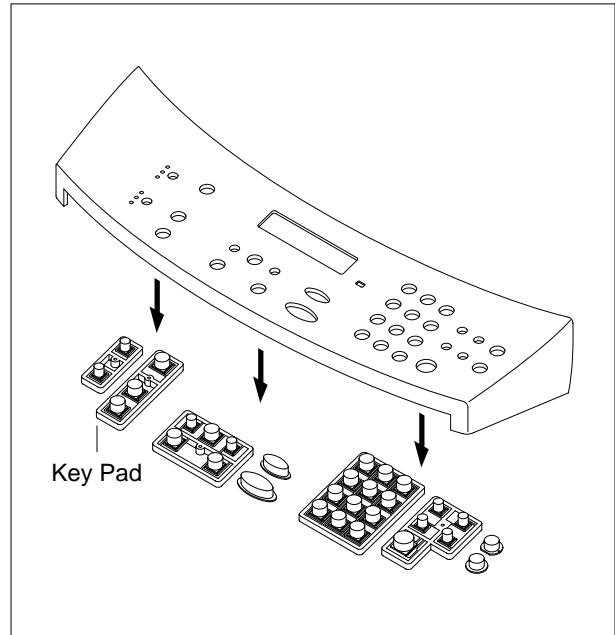

2. Remove the Contact Rubber from the OPE Cover.

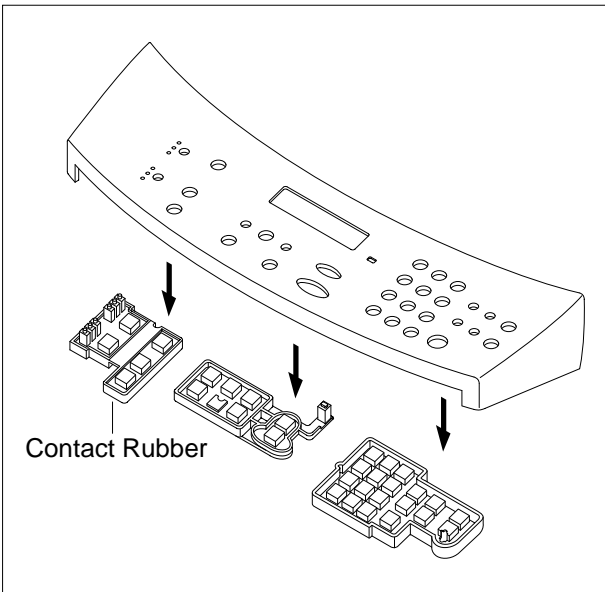

5.8 Middle Cover & Exit Roller

1. Before you remove the Exit Roller, you should remove:

- Rear Cover (see page 5-2)
- Front Cover Ass'y (see page 5-4)
- Side Cover (LH, RH) (see page 5-3)
- Scanner Ass'y (see page 5-5)

2. Remove the six screws securing the Middle Cover.

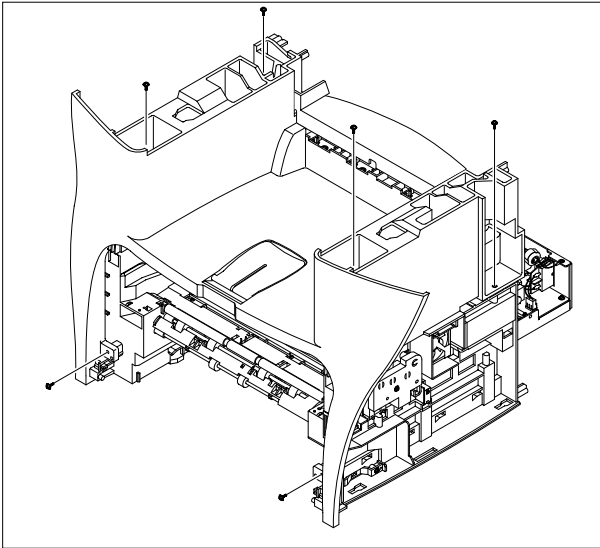

3. Unlatch the Middle Cover Securing the Frame Ass'y, using a proper tool as shown below. Then lift the Middle Cover out.

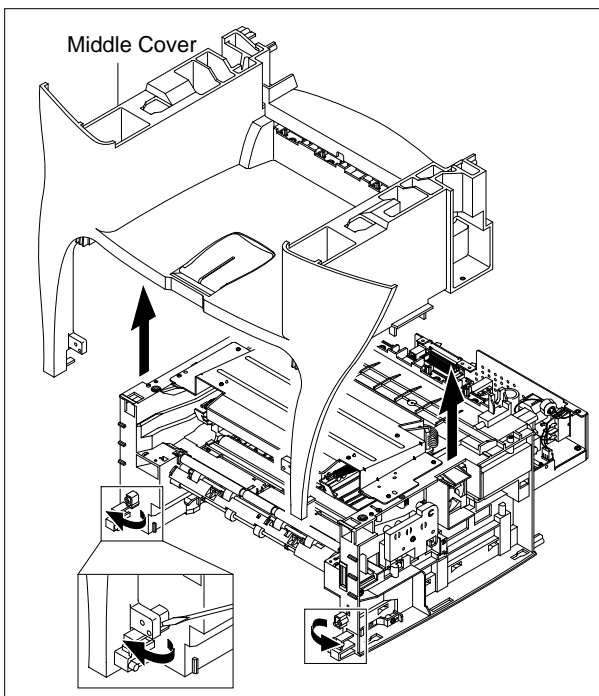

4. Remove the two screws securing the Rear-Upper Cover, as shown below

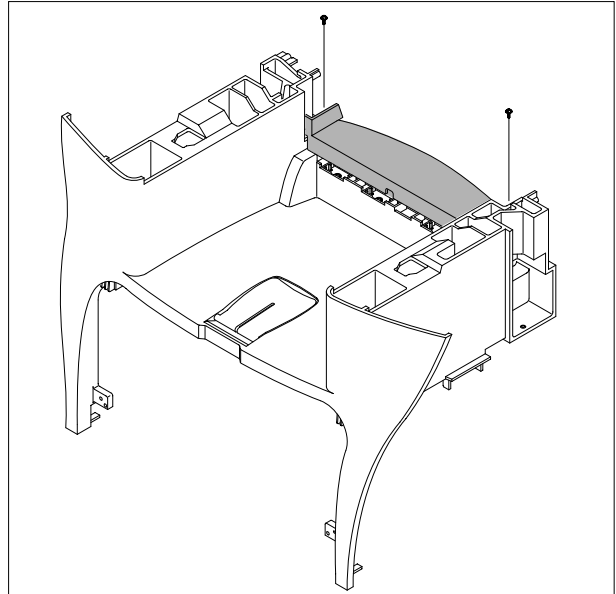

5. Remove the Exit Gear, Bearing and Exit Roller as shown below.

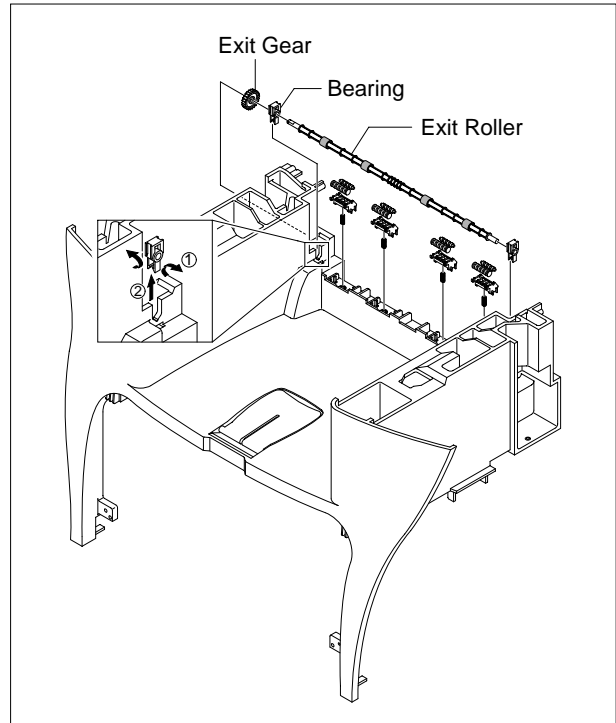

5.9 Engine Shield Ass'y

1. Before you remove the Engine Shield Ass'y, you should remove:

- Rear Cover (see page 5-2)
- Side Cover(LH, RH) (see page 5-3)
- Scanner (see page 5-5)

2. Remove the two screws securing and unplug the FPC cable From the Main PBA. Then remove the LIU PBA

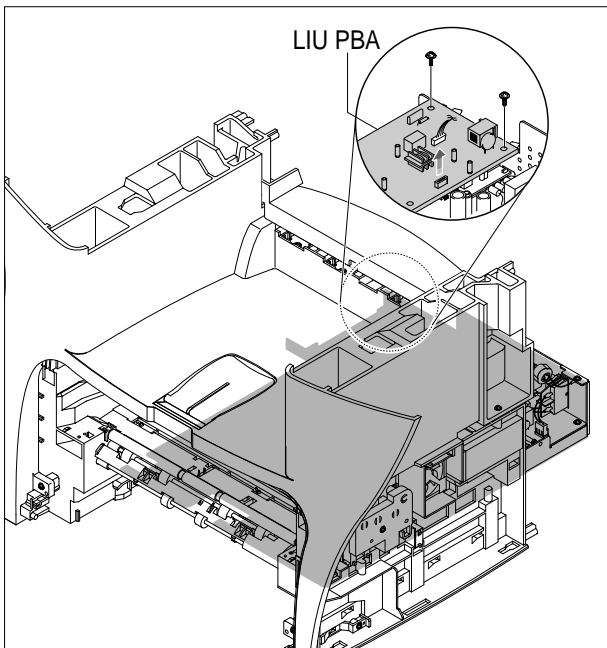

4. Remove the ten screws securing the Engine Shield Ass'y and remove it. Then unplug the all the connectors from the Main PBA and SMPS.

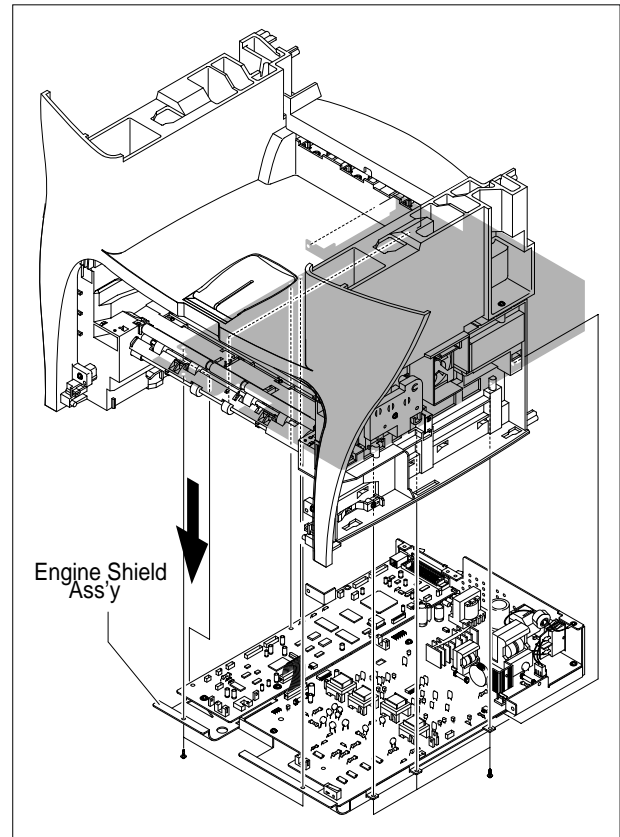

3. Unplug the two connectors.

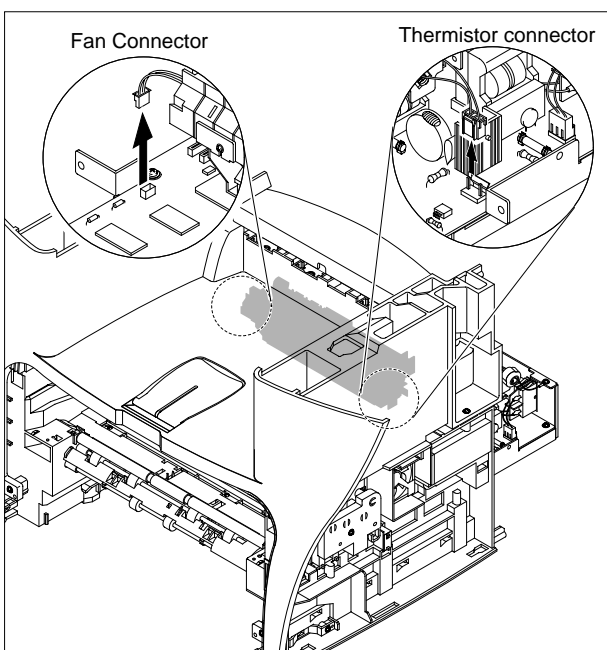

5.10 Main PBA

1. Before you remove the Main PBA, you should remove:
 - Engine Shield Ass'y(see page 5-12)
2. Unplug the one connector and remove the five screws securing the Main PBA. Then lift the Main PBA out, as shown.

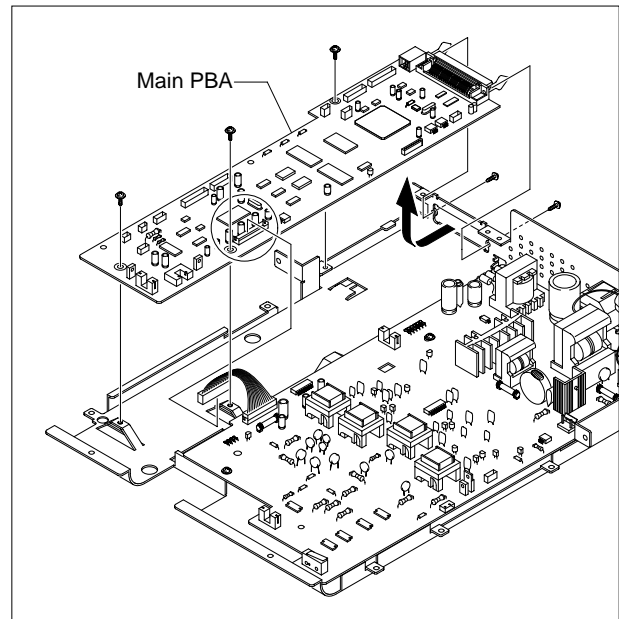

5.11 SMPS

1. Before you remove the SMPS, you should remove:
 - Engine Shield Ass'y(see page 5-12)

2. Remove the three screws securing the Inlet Bracket and remove it

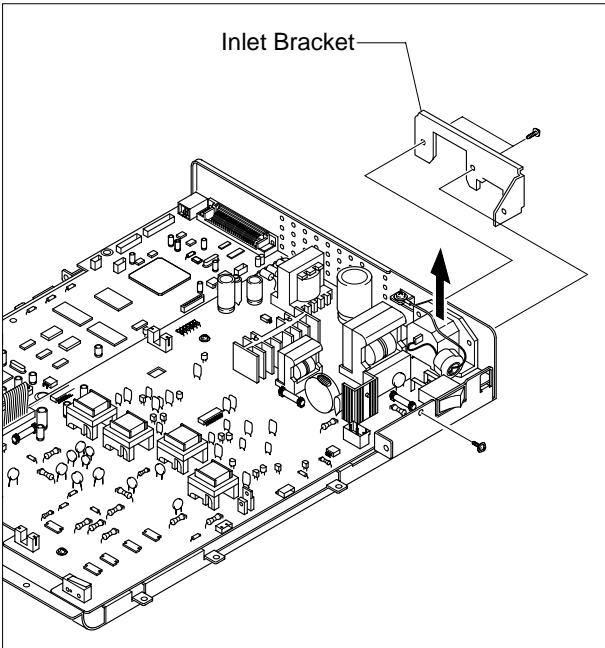

3. Unplug the one connector and remove the one screw securing the Engine Shield.

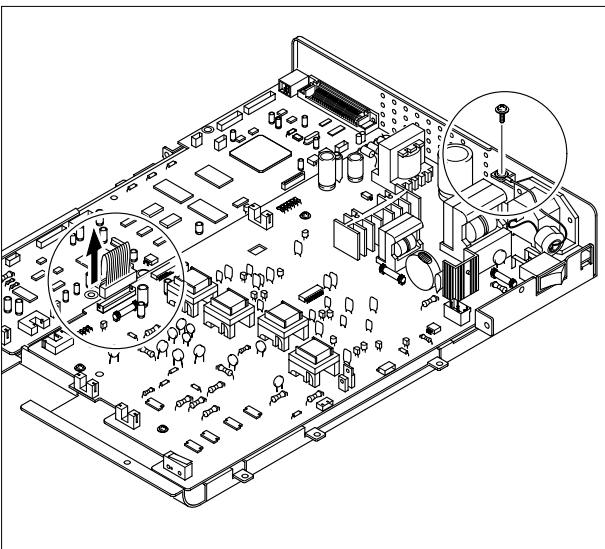

4. Remove the three screws securing the SMPS. Then lift the SMPS out, as shown below.

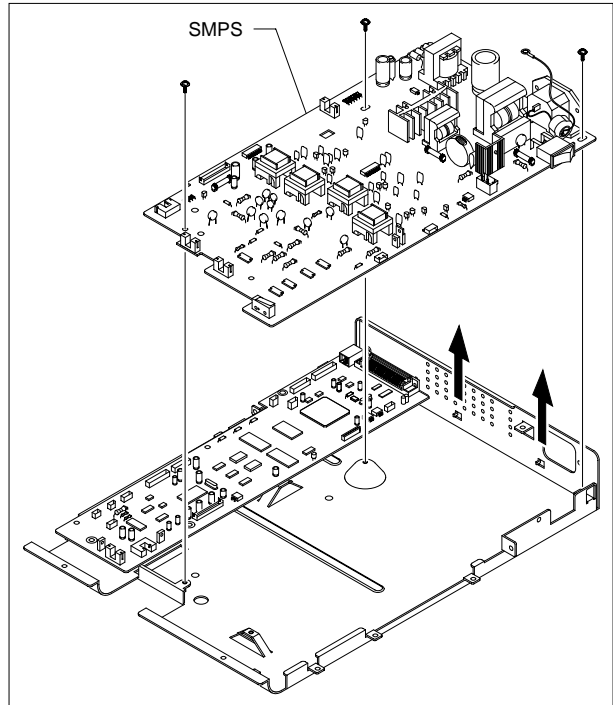

5.12 Fuser Ass'y

1. Before you remove the Fuser Ass'y, you should remove:
 - Rear Cover (see page 5-2)

2. Unplug the two connectors from the Main PBA and SMPS, as shown below. Then remove the four screws securing the Fuser Ass'y and remove it.

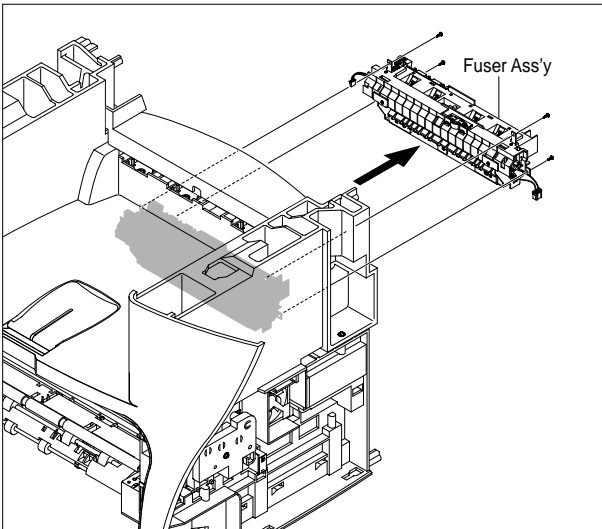

3. Remove the two screws securing the Thermostat. Then lift the Thermostat out

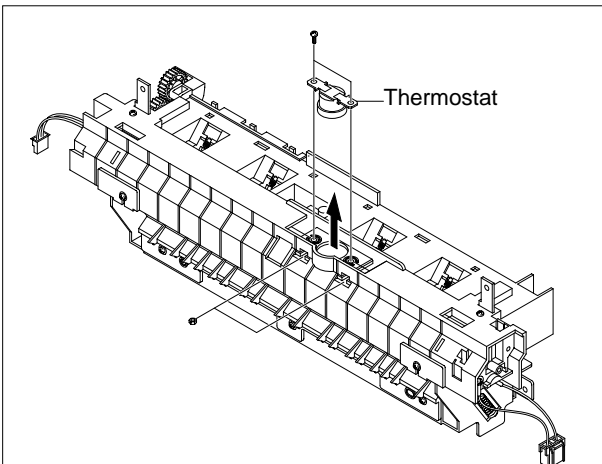

4. Remove the two screws securing the Halogen Lamp. Then take out the Halogen Lamp from the Heat Roller

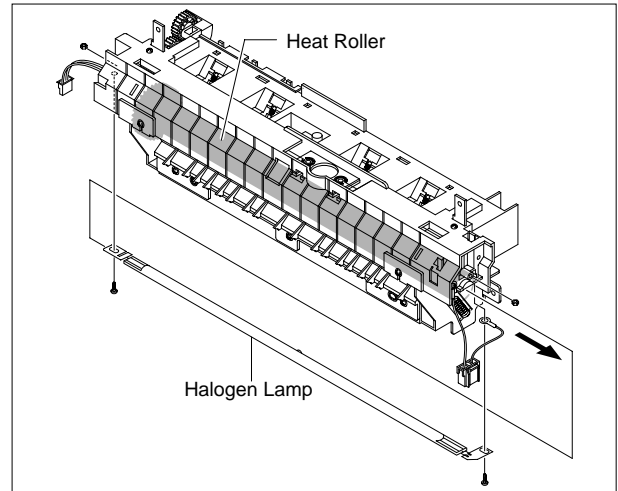

5. Remove the one screw securing the Idle Gear and remove it.

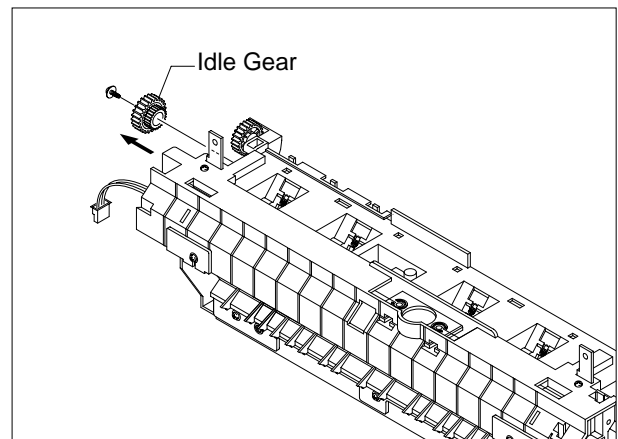

6. Remove the four screws securing the Fuser Cover and remove it, as shown below.

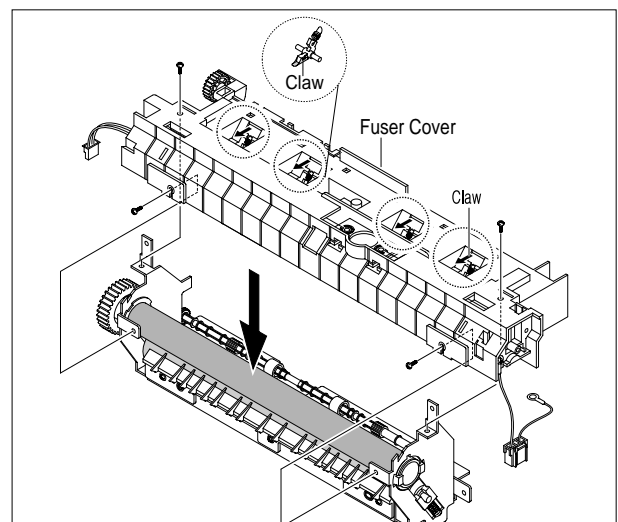

7. Unwrap the Thermister Harness, as shown below.

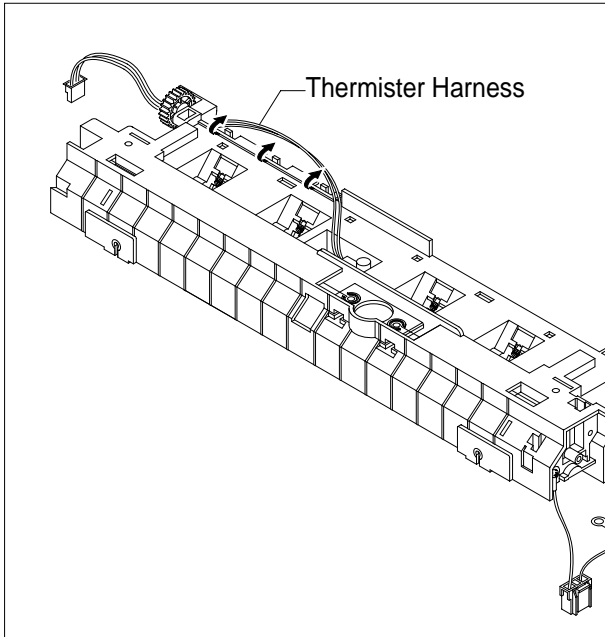

8. Remove the one screw securing the Thermister and remove it, as shown below.

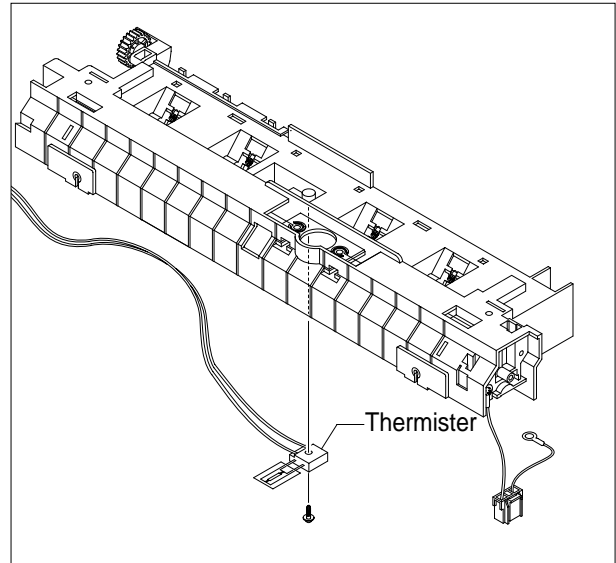

5.13 Fan

1. Before you remove the Fan, you should remove:
 - Rear Cover (see page 5-2)
 - Side Cover (RH) (see page 5-3)

2. Unplug the connector from the SMPS and remove the one screw. Then take out the Fan.

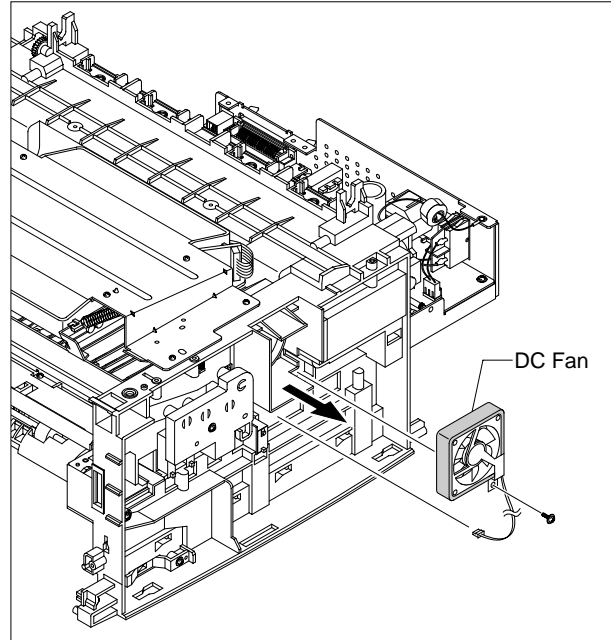

5.14 LSU

1. Before you remove the LSU, you should remove:

- Rear Cover (see page 5-2)
- Side Cover (LH, RH) (see page 5-3)
- Scanner Ass'y (see page 5-5)
- Front Cover (see page 5-4)
- Middle Cover (see page 5-11)

2. Unplug the two connectors.

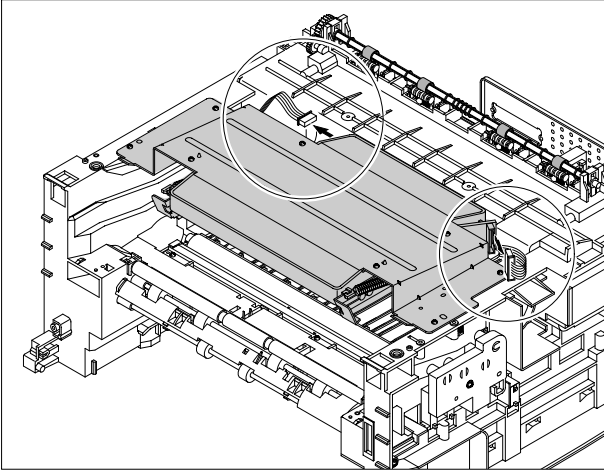

3. Remove the three screws securing the LSU and remove it.

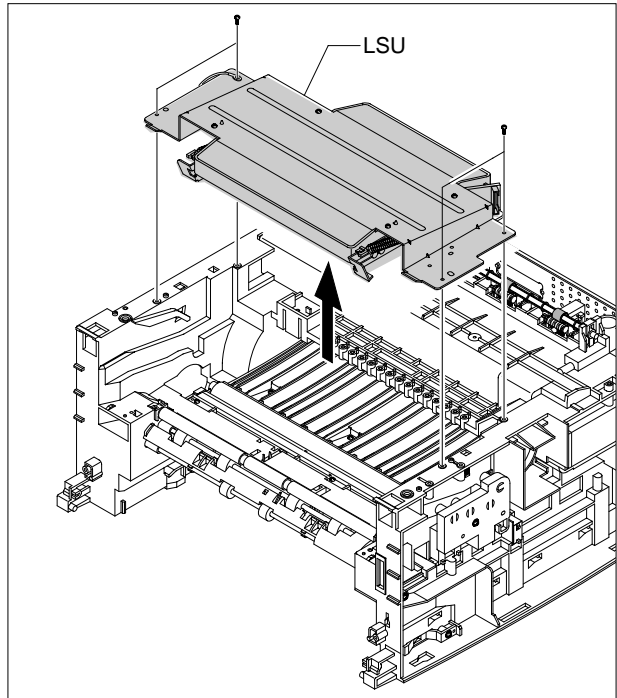

5.15 Drive Ass'y

1. Before you remove the Drive Ass'y, you should remove:

- Rear Cover (see page 5-2)
- Side Cover (LH) (see page 5-3)

2. Remove the six screws securing the Drive Ass'y.

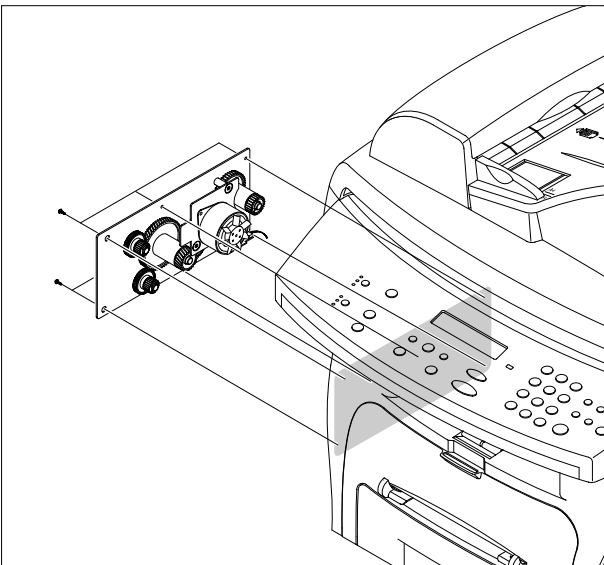

3. Take out the Drive Ass'y, then unplug the connector from the Main PBA, as shown below.

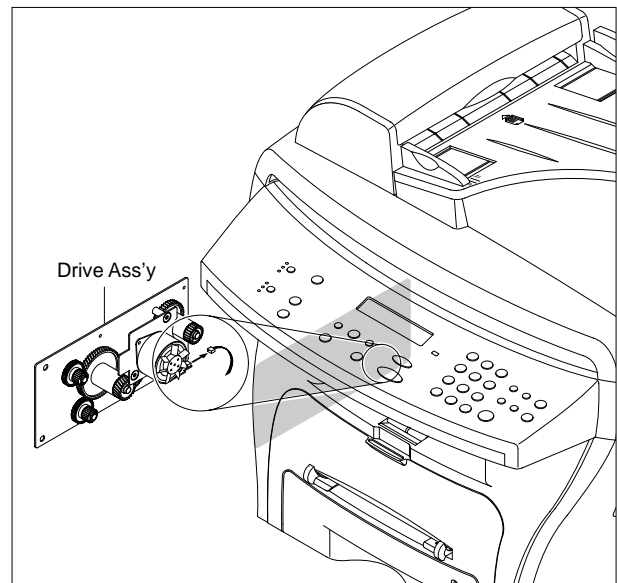

5.16 Transfer Ass'y

1. Before you remove the Transfer Ass'y, you should remove:

- Rear Cover (see page 5-2)
- Side Cover (LH, RH) (see page 5-3)
- Scanner Ass'y (see page 5-5)
- Front Cover (see page 5-4)
- Middle Cover (see page 5-11)
- LSU (see page 5-18)

2. Remove the three screws securing the Transfer Earth and remove it.

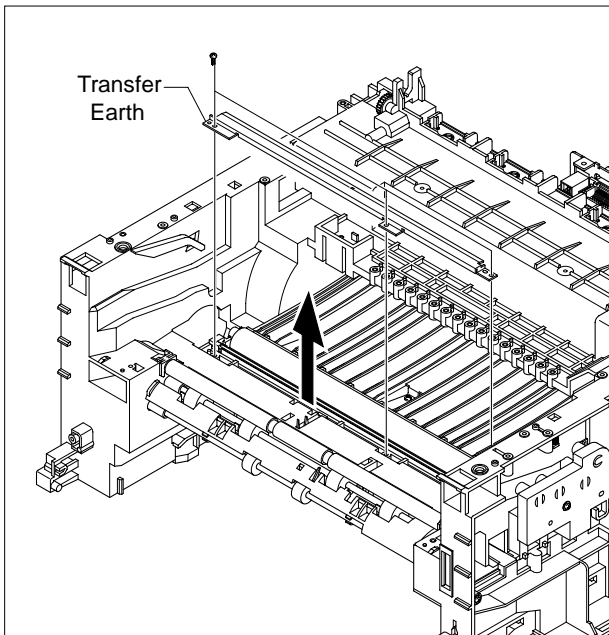

3. Unplug the PTL Holder connector, then remove the PTL Holder and PTL Lens, as shown below.

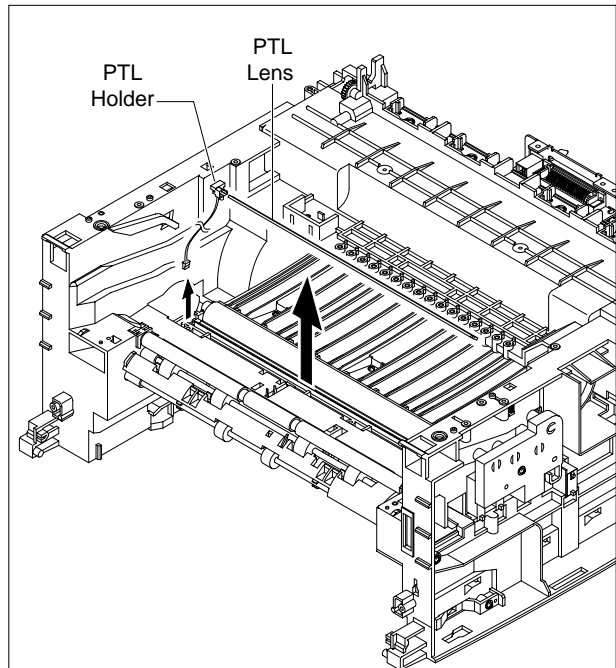

4. Unlatch the Bushing and remove it. Then lift the Transfer Roller out, as shown below.

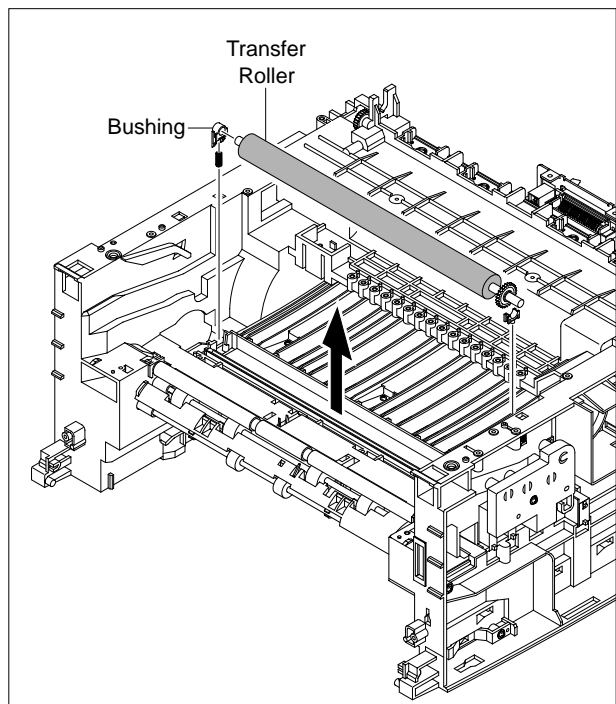

5.17 Feed Ass'y

1. Before you remove the Feed Ass'y, you should remove:

- Rear Cover (see page 5-2)
- Side Cover (LH, RH) (see page 5-3)
- Scanner Ass'y (see page 5-5)
- Front Cover (see page 5-4)
- Middle Cover (see page 5-11)
- Drive Ass'y (see page 5-18)

2. Remove the two screws securing the Guide Paper and remove it.

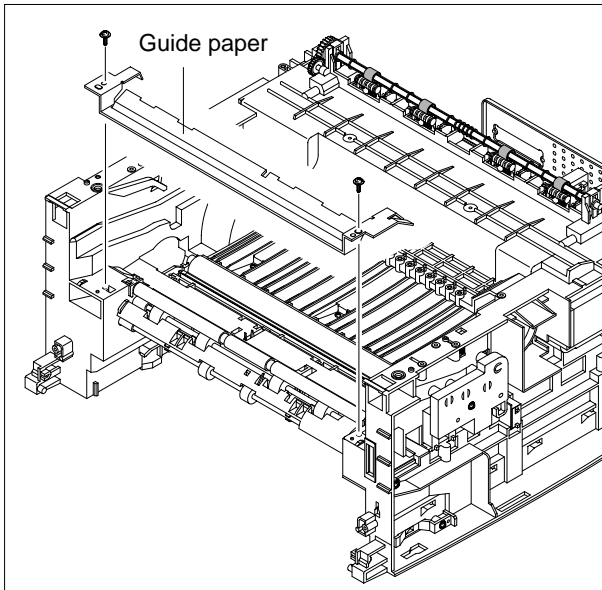

3. Pull up the Feed Idle Bushing and Feed Idle Shaft, as shown below.

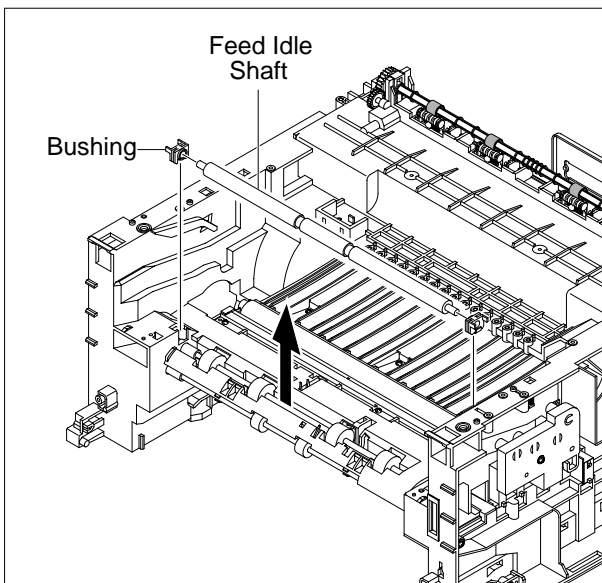

4. Remove the three screws securing the Feed Bracket and remove it.

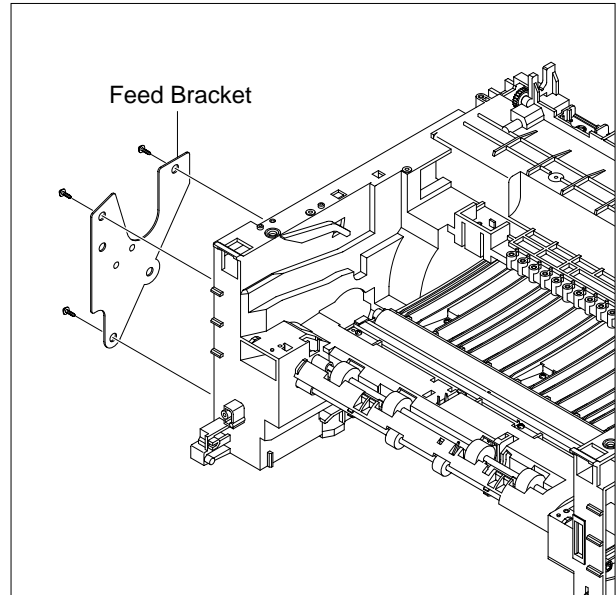

5. Remove the Idle Gear and Feed Gear2.

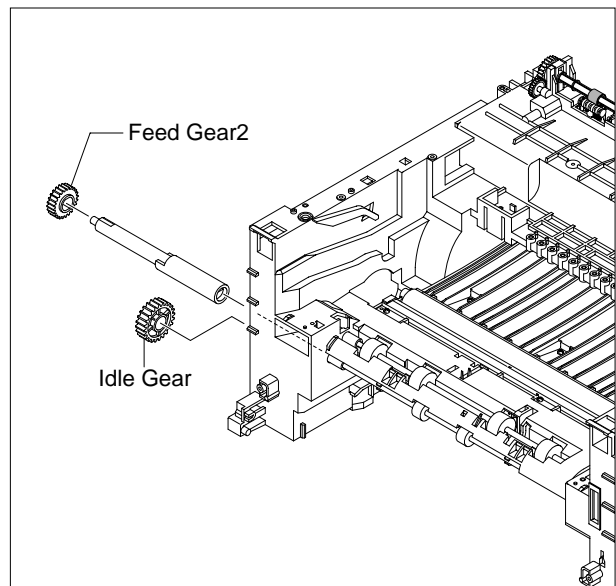

6. Remove the Feed Gear1 Ass'y.

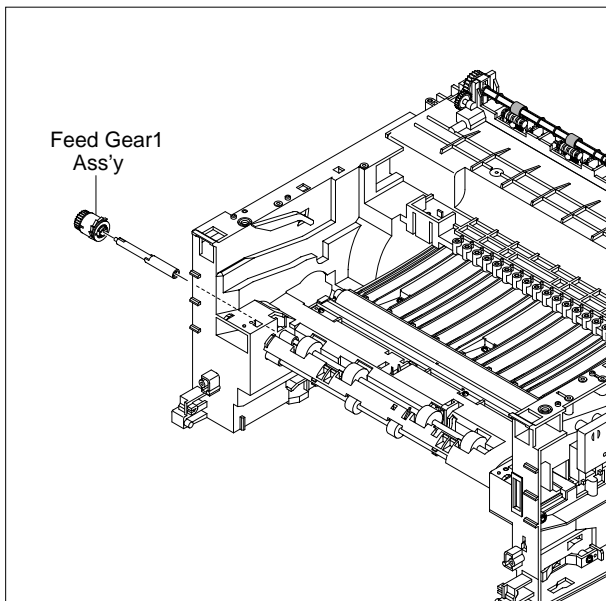

7. Pull up the Feed Roller and Feed Roller1.

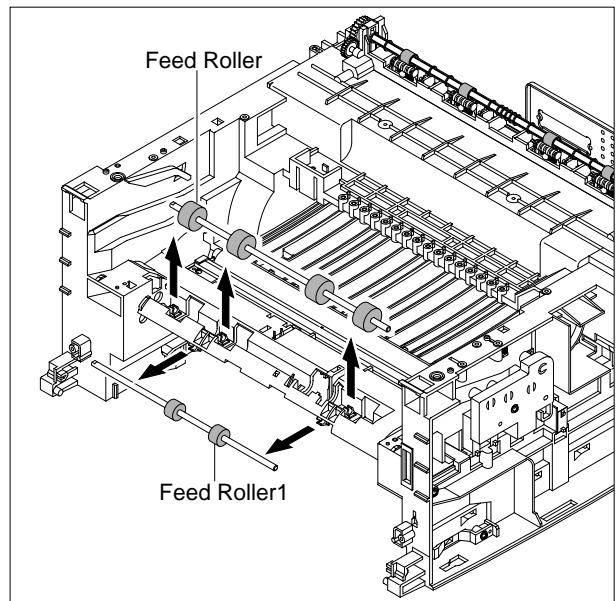

5.18 Pick-Up Ass'y & Solenoid

1. Before you remove the Pick-Up Ass'y, you should remove:

- Rear Cover (see page 5-2)
- Side Cover (LH, RH) (see page 5-3)
- Front Cover (see page 5-4)
- Scanner Ass'y (see page 5-5)
- Middle Cover (see page 5-11)
- Engine Shield Ass'y (see page 5-12)
- Drive Ass'y (see page 5-18)

2. Remove the three screws securing the Feed Bracket and remove it.

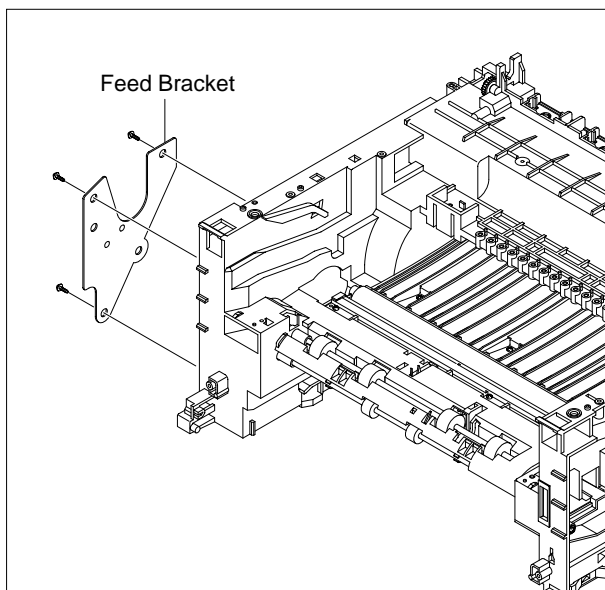

3. Remove the Pick-Up Gear Ass'y.

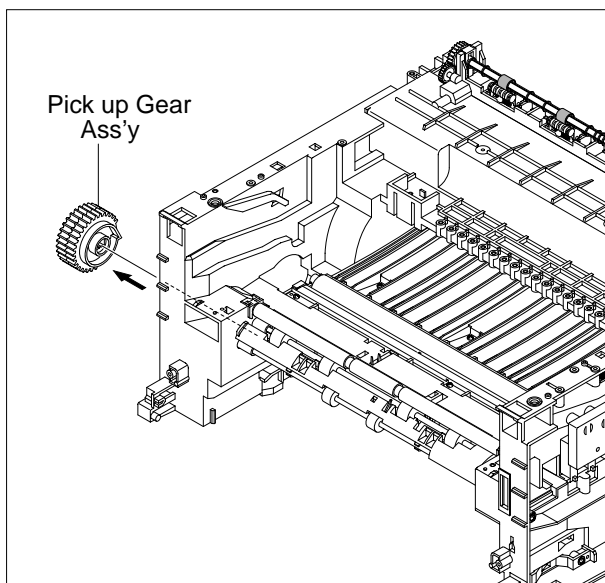

4. Take out the Pick-Up Ass'y, as shown below.

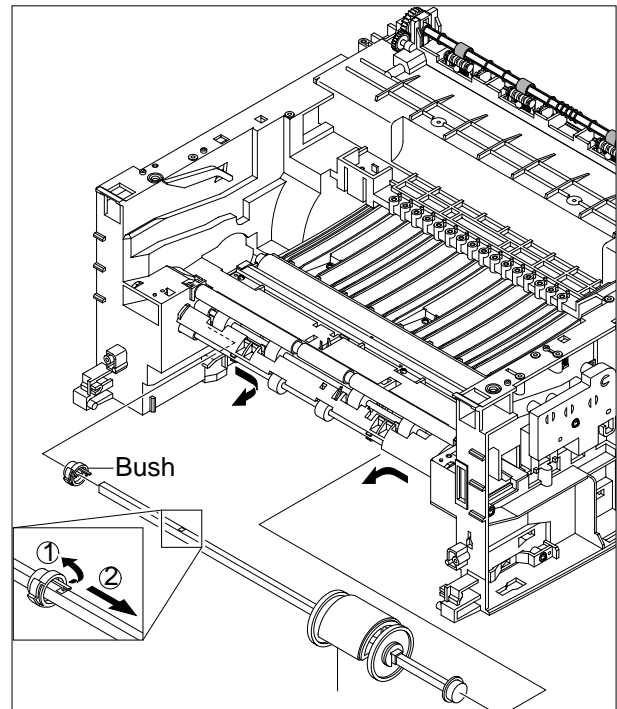

5. Remove the two screws securing the Manual Solenoid and Pick-Up Solenoid. Then remove Manual Solenoid and Pick-Up Solenoid.

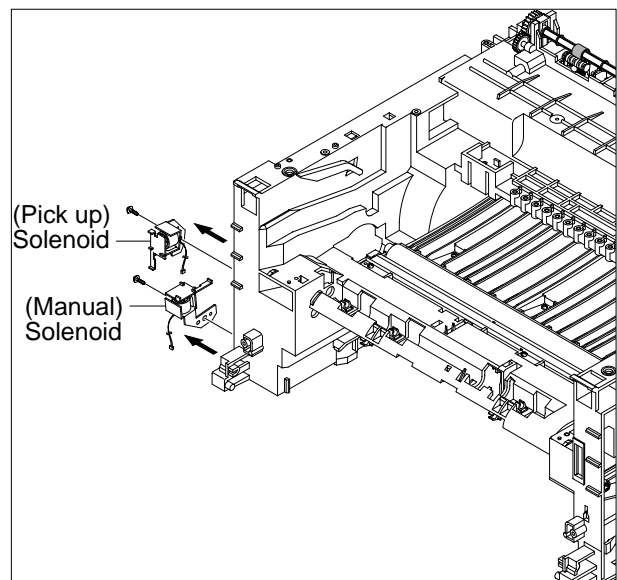

6. Alignment and Adjustments

This chapter describes the main functions for service, such as the product maintenance method, the test output related to maintenance and repair, DCU using method, Jam removing method, and so on.

6.1 Paper path

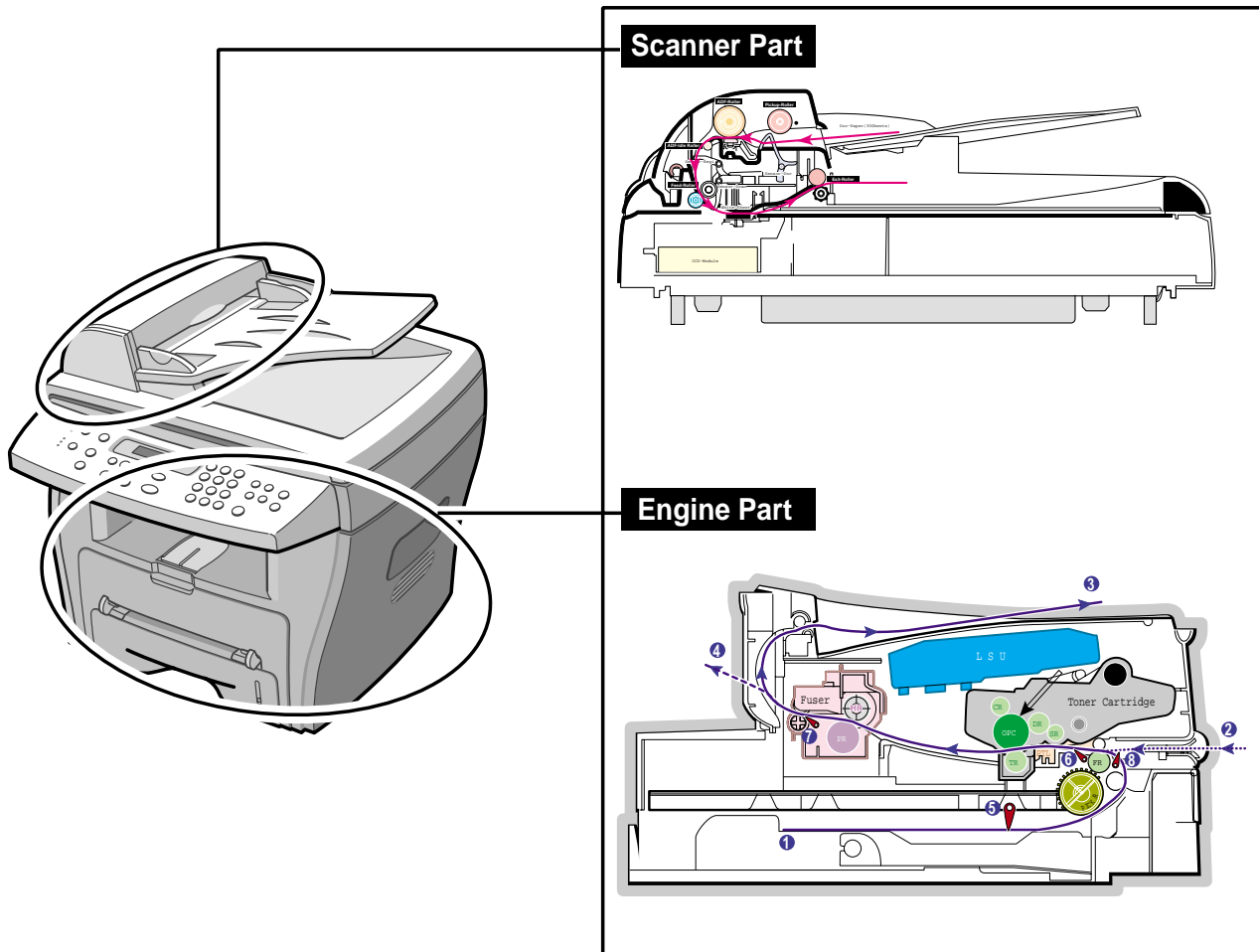

6.1.1 Copy & Scan Document Path

Scanner Part

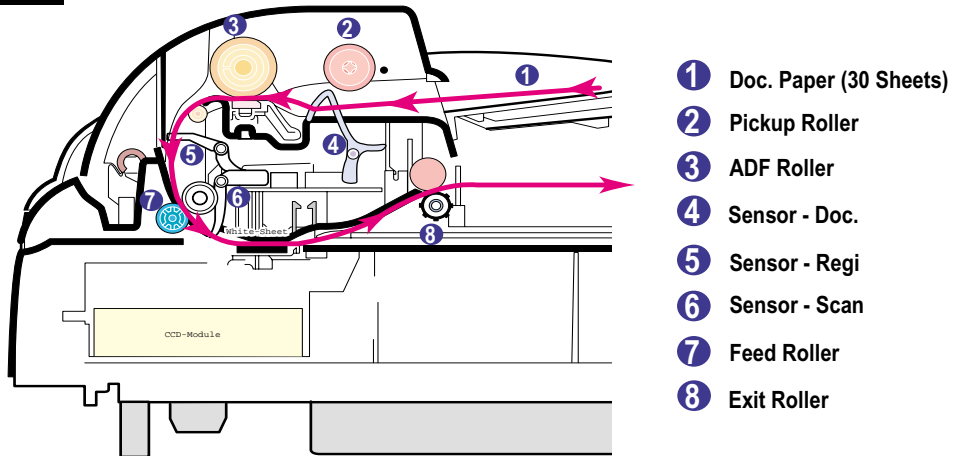

6.1.2 Printer Paper Path

- 1) After receiving a print job, the printer feeds the paper from the cassette or manual feeder.
- 2) The fed paper passes the paper feeding sensor. (Jam 0 occurs if the sensor is not operated after a certain time passes)
- 3) The paper passes the paper feeding sensor moving to the paper exit sensor via printing process. (Jam 1 occurs if the paper exit sensor is not operated after a certain time passes)
- 4) The paper passes the paper exit sensor moving out of the set. (Jam 2 occurs if the sensor is still operated after a certain time passes.)

Engine Part

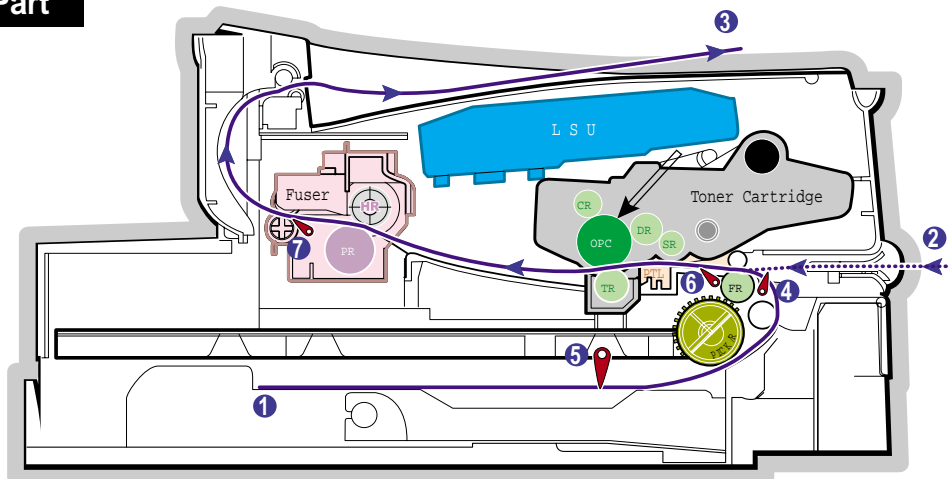

6.2 Clearing Paper Jams

Occasionally, paper can be jammed during a print job. Some of the causes include:

- The tray is loaded improperly or overfilled.
- The tray has been pulled out during a print job.
- The front cover has been opened during a print job.
- Paper was used that does not meet paper specifications.
- Paper that is outside of the supported size range was used.

If a paper jam occurs, the On Line/Error LED on the control panel lights red. Find and remove the jammed paper. If you don't see the paper, open the covers.

Do not use a tweezers or a sharp metal tool when removing a jam.

The covering of a metal part can be removed which can cause an electric leakage.

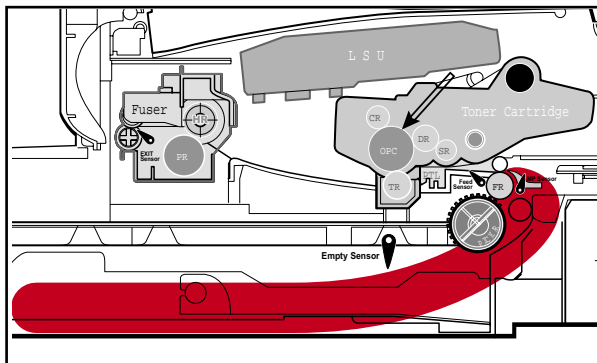

Paper Jam0

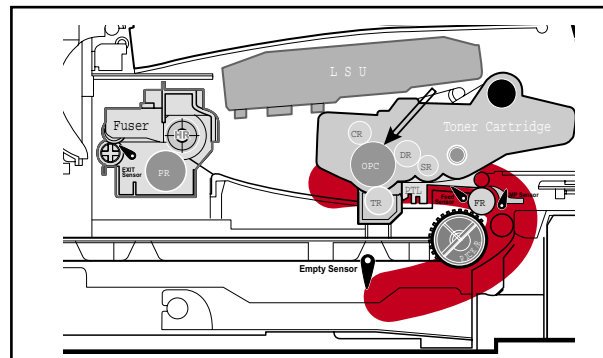

Paper Jam1

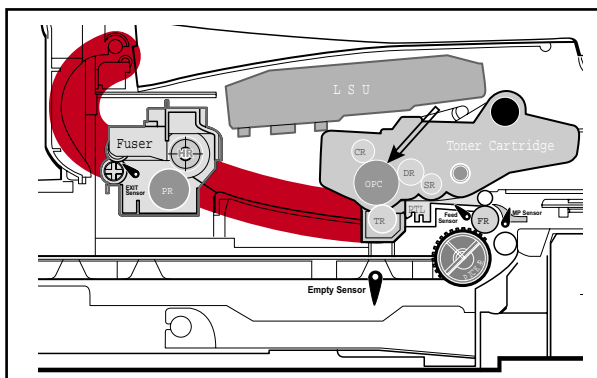

Paper Jam2

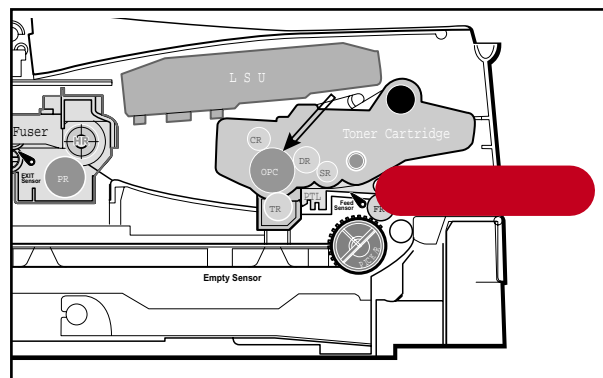

Bypass Jam

6.2.1 Clearing Document Jams

If a document jams while it is feeding through the ADF (Automatic Document Feeder), "DOCUMENT JAM" appears on the display.

6.2.1.1 Input Misfeed

1) Open the ADF top cover.



3) Close the ADF top cover. Then load the documents back into the ADF.

NOTE: To prevent document jams, use the document glass for the thick, thin or mixed documents.

2) Pull the document gently to the right and out of the ADF.

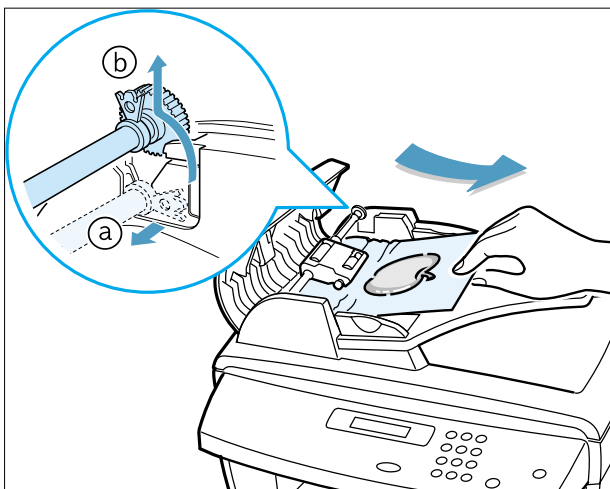

6.2.1.2 Exit Misfeed

- 1) Open the document cover and turn the release knob to remove the misfed documents from the exit area.
- 2) Close the document cover. Then load the documents back into the ADF.

6.2.1.3 Roller Misfeed

- 1) Open the document cover.

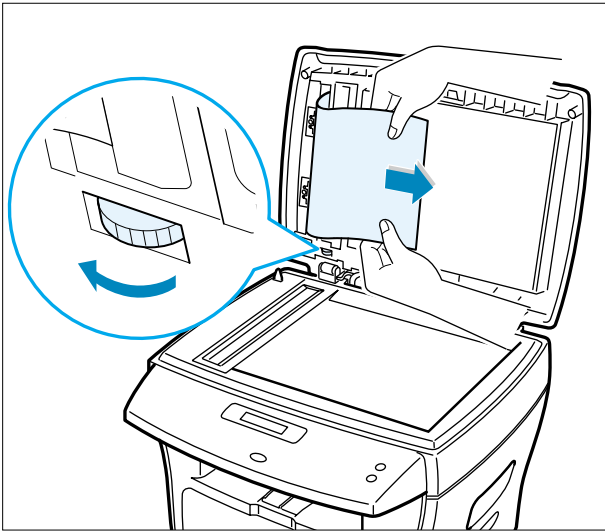

- 2) Turn the release knob so that you can easily remove the misfed document. Remove the document from the ADF or the feed area by carefully pulling it towards the right by using both hands.

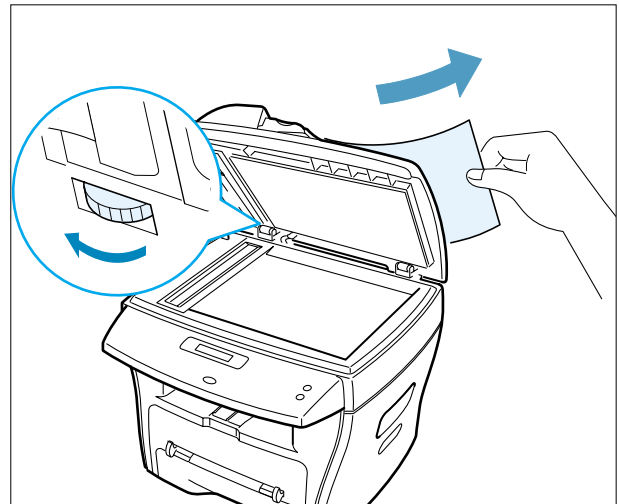

- 3) Close the document cover. Then load the documents back into the ADF.

6.2.2 Clearing Paper Jams

If paper jams occur, "PAPER JAM" appears on the display. Refer to the table below to locate and clear the paper jam.

PAPER JAM 0	: In the paper feed area
PAPER JAM 2	: In the paper exit area
PAPER JAM 1	: In the fuser area or around the toner cartridge
BYPASS JAM	: In the Bypass tray

Follow the steps below to clear a jam. To avoid tearing the paper, pull the jammed paper out gently and slowly.

6.2.2.1 JAM0 (In the Paper Feed Area)

- 1) Open and close the front cover. The jammed paper automatically exits the machine.
If the paper does not exit, continue to Step 2.

- 2 Pull the paper tray open.

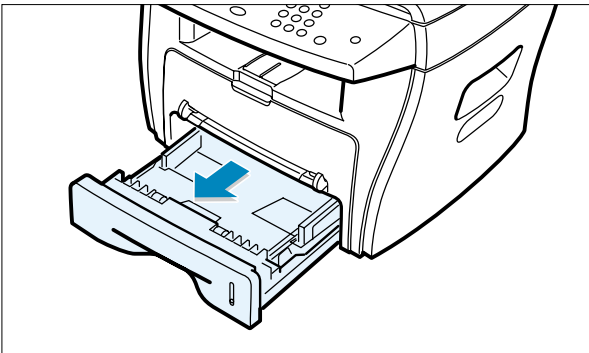

- 3) Remove the jammed paper by gently pulling it straight out.

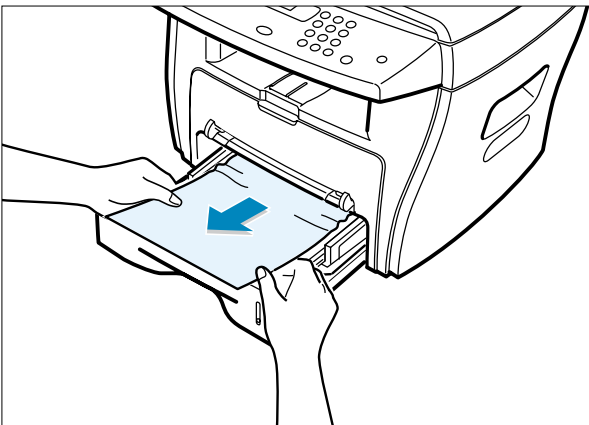

If there is any resistance when you pull the paper, or the paper is not seen in this area, skip to the fuser area around the toner cartridge

- 4) Insert the paper tray into the machine until it snaps into place.

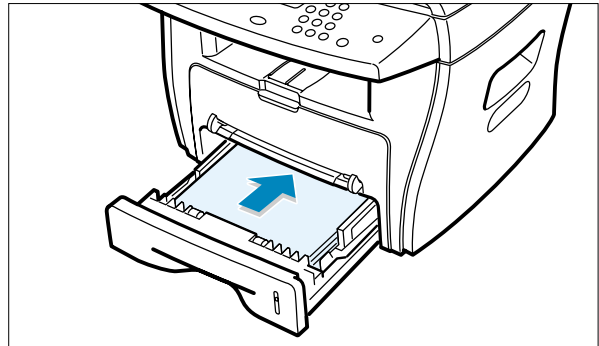

- 5) Open and close the front cover to resume printing.

6.2.2.2 JAM 2 (In the Paper Exit Area)

1) Open and close the front cover. The jammed paper automatically exits the machine.
If the paper does not exit, continue to Step 2.

2) Gently pull the paper out of the front output tray.

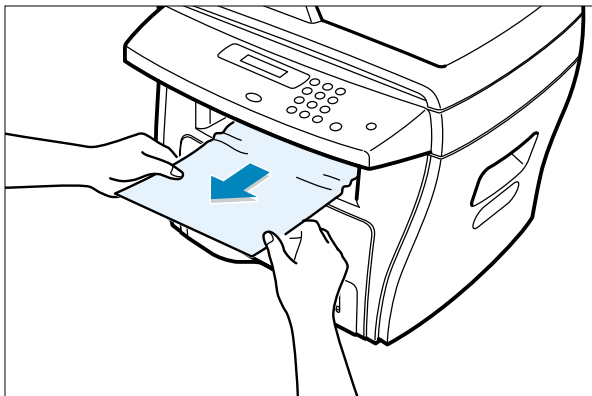

3) If there is any resistance when you pull the paper, or the paper is not seen in the front output tray, open the rear cover.

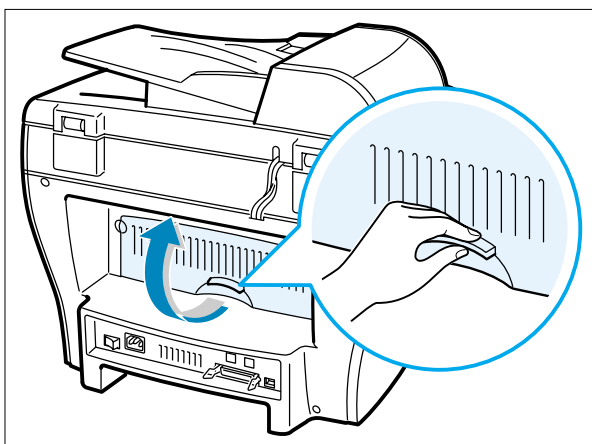

4) Remove the jammed paper by gently pulling it straight out.

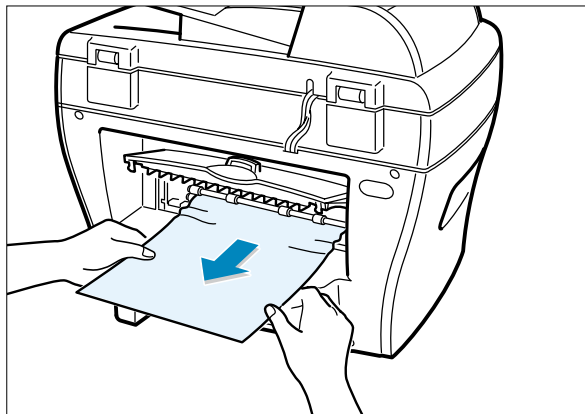

5) Close the rear cover.

6) Open and close the front cover to resume printing.

6.2.2.3 JAM1 (In the Fuser Area of Around the Toner Cartridge Area)

NOTE : The fuser area is hot. Be careful when removing paper from the machine.

1) Open the front cover and remove the toner cartridge.

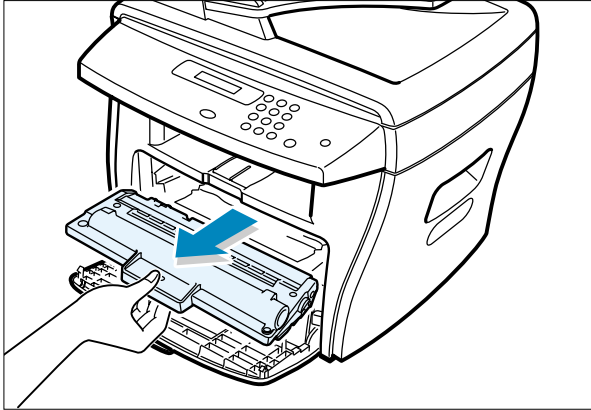

3) Replace the toner cartridge and close the front cover. Printing automatically resumes.

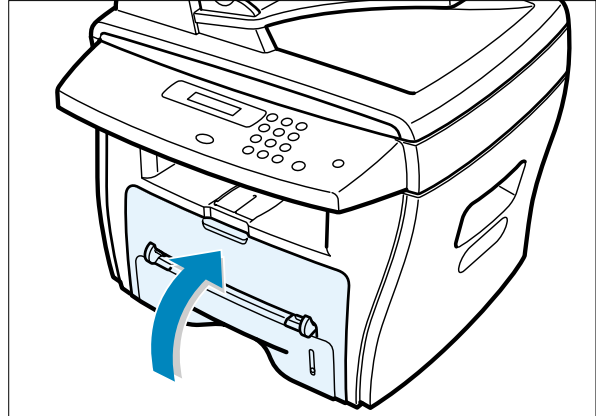

2) Remove the jammed paper by gently pulling it straight out.

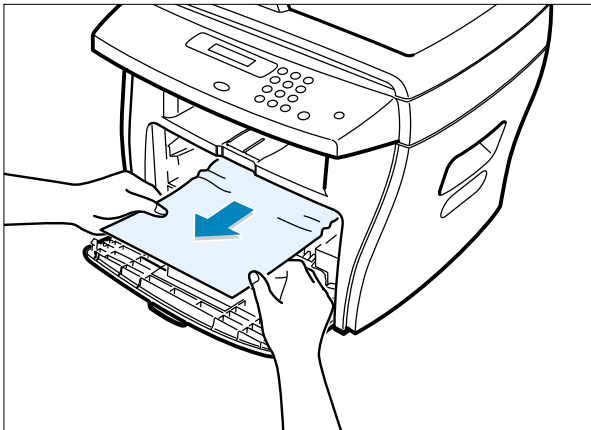

6.2.2.4 BYPASS JAM (In the Bypass Tray)

"BYPASS JAM " appears on the display when the machine does not detect paper in the Bypass tray due to no paper or improper paper loading when you try to print using the Bypass tray.

"BYPASS JAM " also may occur when the paper is not properly fed into the machine through the Bypass tray. In that case, pull the paper out of the machine.

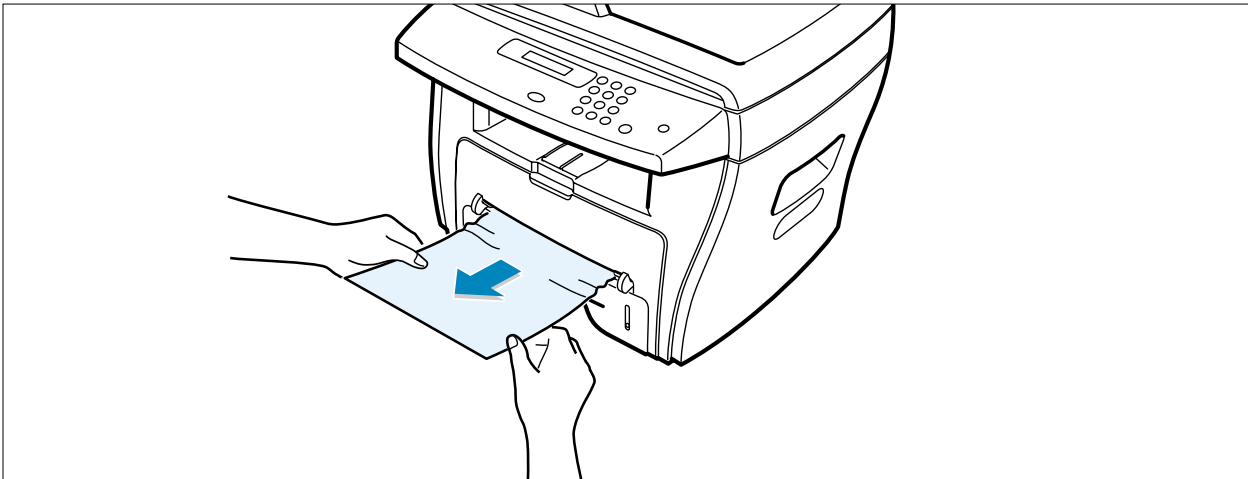

6.2.2.5 Tips for Avoiding Paper Jams

By selecting the correct paper types, most paper jams can be avoided. If a paper jam occurs, follow the steps outlined in "Clearing Paper Jams "

- Follow the procedures in "Loading Paper ". Ensure that the adjustable guides are positioned correctly.
- Do not overload the paper tray. Ensure that the paper is below the paper capacity mark on the inside wall of the paper tray.
- Do not remove the paper from the tray while printing.
- Flex, fan and straighten the paper before loading.
- Do not use creased, damp, or highly curled paper.
- Do not mix paper types in the paper tray.
- Use only recommended print materials. See "Paper Specifications "
- Ensure that the recommended print side is facing down when loading paper in the paper tray and facing up in the Bypass tray.

6.3 User Mode

The figure below shows the possible user function settings. Usage details are provided in the user manual.

In the service manual, the items are about the possible set-up by user.

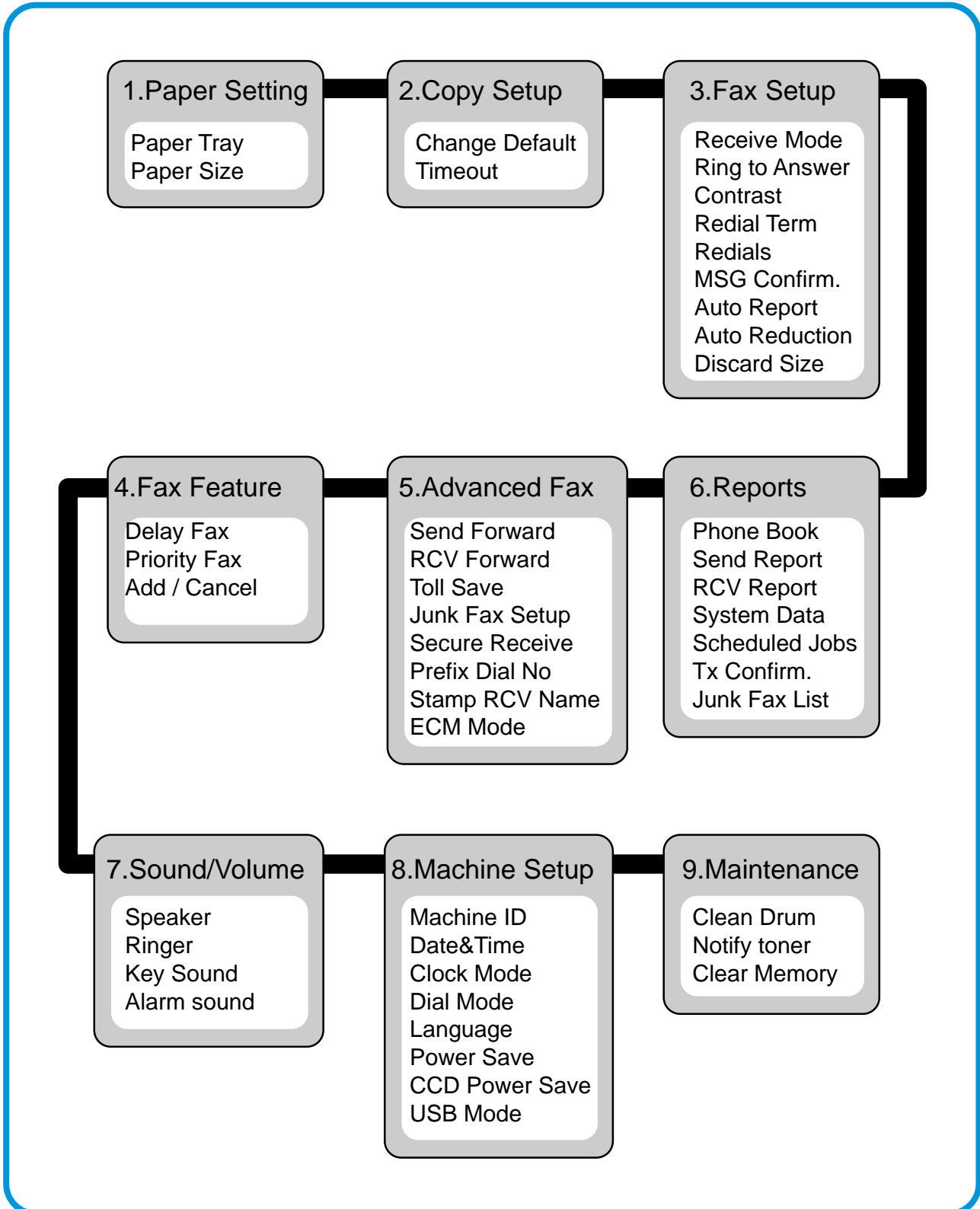







6.4 Tech Mode

6.4.1 How to Enter Tech Mode

In service (Tech) mode, the technician can check the machine and perform various tests to isolate the cause of a malfunction.

While in Tech mode, the machine still performs all normal operations.

To enter the Tech mode

To enter the Tech mode, press  →  →  →  →  →  in sequence, and the LCD briefly displays 'TECH', the machine has entered service (Tech) mode.

6.4.2 Setting-up System in Tech Mode

WorkCentre PE16

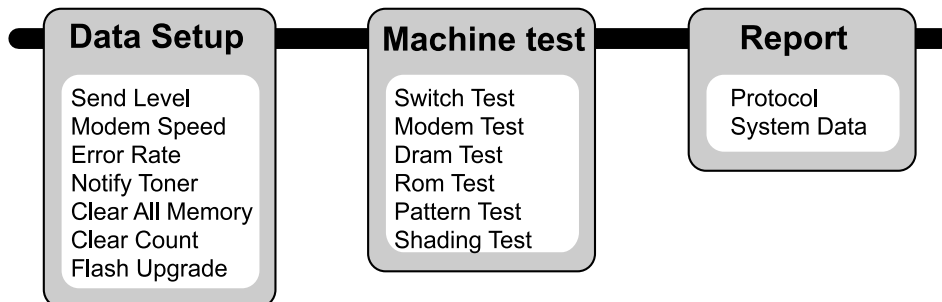

6.4.3 Data Setup

SEND LEVEL

You can set the level of the transmission signal. Typically, the Tx level should be under -12 dBm.

Caution : *The Send Fax Level is set for optimum performance when shipped from the factory. Never change settings arbitrarily.*

MODEM SPEED

You can set the maximum modem speed.

Modem speed is automatically set to the lower speed when communicating with a slower speed modem since communication is done using the standard of lowest speed unit to ensure proper transmission/reception. Speed is best set 33.6Kbps as the default setting.

ERROR RATE

When the error rate is about to exceed the set value, the Baud rate automatically adjusts to 2400 bps.

This ensures that the error rate remains below the set value.

You can select the rate between 5% and 10%.

CLEAR ALL MEMORY

The function resets the system to the factory default settings.

This function is used to reset the system to the initial values when the product is functioning abnormally. All the values are returned to the default values, and all the information, which was set by the user, will be erased.

< Method >

1. Select the [MEMORY CLEAR] in the TECH MODE.
2. Push the ENTER button.
3. Select your country. (There are four country groups. Refer to the table below.)
4. Push the ENTER button then it will clear all memory.

NOTICE : *Always perform a memory clear after replacing the main board. Otherwise, the system may not operate properly.*

Country Group	USA/Canada	UK	Russia	Southafrica
Country	USA/Canada Mexico Brazil	UK Germany France Italy Spain Austria Netherlands Belgium Portugal Sweden Norway Denmark Finland Switzerland Greece Ireland Turkey	Russia india Oman Poland Bangladesh Kuwait Moroco Algeria Pakistan UAE Bahrain Srilanka SaudiArabia Chile Peru Argentina Hungary Romania Bulgaria Czech	Southafrica

FLASH UPGRADE

The Firmware Upgrade function has two methods, Local and Remote.

(1) Local Machine

- RCP (Remote Control Panel) mode

This method is for Parallel Port or USB Port. Connect to PC and activate RCP (Remote Control Panel) to upgrade the Firmware.

< Method >

How to Update Firmware using RCP

1. Connect PC and printer with Parallel Cable or USB Cable.
2. Execute RCP and select Firmware Update.
3. Search Firmware file to update with Browse Icon.
4. Click Update icon, firmware file is transmitted to the printer automatically and the printer is initialized when transmission is complete.
5. Click the Refresh icon to check what is updated.

- DOS Command mode

This method is just for Parallel Port. Connect to PC with Parallel cable and enter DOS Command to upgrade the Firmware.

< Method >

1. First, ensure that you have the following files : down.bat, down_com.bin, fprt.exe, and Rom File: file name for upgrade. Save the files in the same folder.
2. In DOS, input as below and push the Enter key. Then, it will be automatically upgraded.
3. There are two commands for the conditions of product.
 - * When the product is in idle condition **down "rom file"**
 - * When the product is in Ready condition (TECH MODE → DATA SETUP → FLASH UPGRADE → LOCAL) **fprt "rom file"**
4. Do not turn off the power while in the upgrade process.

(2) Remote FAX

This function allows a fax with the latest firmware to send files to another fax over the telephone line.

< Method >

1. Setup the fax with the latest firmware to prepare for the upgrade.
(TECH MODE → DATA SETUP → FLASH UPGRADE → REMOTE)
2. Input the fax number, which needs to be upgraded.
(Several faxes can be upgraded at the same time. In that case, enter each fax number.)
3. After you push the Enter button, the firmware file is sent by calling the number(s) entered.
(It takes 10~15 minutes to send the file.)

< Caution >

1. sending and receiving fax must be the same model.
2. A sending fax must be set up in ECM mode, and receiving memory must be set up as 100%.
If not, the function will operate abnormally.

6.4.4 Machine Test

SWITCH TEST

Use this feature to test all keys on the operation control panel. The result is displayed on the LCD window each time you press a key.

MODEM TEST

Use this feature to hear various transmission signals to the telephone line from the modem and to check the modem. If no transmission signal sound is heard, it means the modem part of the main board malfunctioned.

DRAM TEST

Use this feature to test the machine's DRAM. The result appears in the LCD display.

If all memory is working normally, the LCD shows << O K >>

ROM TEST

Use this feature to test the machine'S ROM. The result and the software version appear in the LCD display.

- FLASH VER : 1.00 V
- ENGINE VER :1.00V

PATTERN TEST

Using this pattern printout, you can check if the printer mechanism is functioning properly. this feature is needed during production, it is not required for service.

SHADING TEST

The function is to get the optimum scan quality by the specific character of the CCD (Charge Coupled Device). If the copy image quality is poor, perform this function to check the condition CCD unit.

< Method >

1. Select the [ADJUST SHADING] at the TECH MODE.
2. Push the SET UP button then an image will be scanned.
3. After the scan, CCD SHADING PROFILE will be print out.
4. If the printed image is different to the image, the CCD is defect.

NOTE : When you test CCD, make sure that the cover is closed.

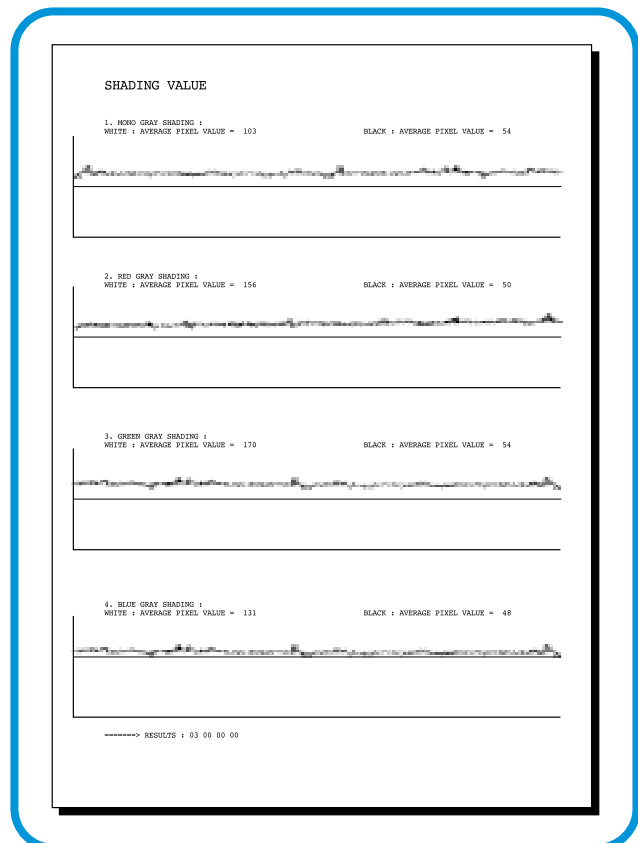

6.4.5 Report

PROTOCOL LIST

This list shows the sequence of the CCITT group 3 T.30 protocol during the most recent sending or receiving operation. Use this list to check for send and receive errors. If a communication error occurs while the machine is in TECH mode, the protocol list will print automatically.

SYSTEM DATA







This feature provides a list of the user system data settings and tech mode settings.

6.5 Engine Test Mode

The Engine Tests Mode supplies useful functions to check the condition of the engine. It tests the condition of each device and displays the result of the test on the LCD. It is classified into 5 functions (0~4), that are shown below.

6.5.1 To enter the Engine Test Mode

To enter the Engine Test mode

Press  →  →  →  →  →  in sequence, and the LCD briefly displays 'Engine Test', the machine has entered Engine Test Mode.

6.5.2 Diagnostic

NO.	Sub No.	Engine test	Remark
0	1	Motor Test	1 : On, 2 : Off
	2	PickUp Test	1 : On, 2 : Off
	3	Fan Test	1 : On, 2 : Off
	4	Manual Clt Test	1 : On, 2 : Off
	5	PTL Test	1 : On, 2 : Off
1	1	LSU Motor Test	1 : On, 2 : Off
	2	LSU Hsync Test	1 : On, 2 : Off
	3	LD Test	1 : On, 2 : Off
2	1	Feed Sen Test	Check : Check Start
			Next : Next Sensor Check
	2	Exit Sen Test	Check : Check Start
			Next : Next Sensor Check
	3	Cover Sen Test	Check : Check Start
			Next : Next Sensor Check
4	Empty Sen Test	Check : Check Start	
		Next : Next Sensor Check	
5	Manual Sen Text	Check : Check Start	
		Next : Next Sensor Check	
3	1	Therm ADC 180	1 : On, 2 : Off (maintain the fusing temp. 80C)
	2	Therm ADC 140	1 : On, 2 : Off (maintain the fusing temp. 135C)
	3	Therm ADC 120	1 : On, 2 : Off (maintain the fusing temp. 160C)
	4	Therm ADC 100	1 : On, 2 : Off (maintain the fusing temp. 191C)
4	1	MHV Test	1 : On, 2 : Off (-1550V ± 50V)
	2	Dev Bias Test	1 : On, 2 : Off (-430V ± 20V)
	3	THV EN/NEG Test	1 : On, 2 : Off (-1000V +300V/-150V)
	4	THV ON (1300V)	1 : On, 2 : Off (+1300V ± 20V)
	5	THV ADC 1300V	1 : On, 2 : Off (ADC Value : 101 ± 5)
	6	THV ADC 600V~3500V	1 : On, 2 : Off (Compare each ADC Value)

6.6 Identify Sale Date

This function confirms the date the consumer bought the product and used it for the first time. When the consumer first operates the machine, it will start a scan and page count. The time the machine was first used is stored in memory.

These settings are retained after memory delete (Clear All Memory).

< Method >

Press MENU, #, 1, 9, 3, # in sequence. Firmware version is displayed on LCD.

Press 1(in the number keypad) : The LCD display shows "Updated date"

Press 2(in the number keypad) : The LCD display shows "Product first use date"

6.7 Consumables and Replacement Parts

The cycle periods listed below are a general guideline for maintenance. The example list is for an average usage of 50 transmitted and received documents per day. Environmental conditions and actual use may cause these periods to vary. The cycle periods given below are for reference only.

COMPONENT	REPLACEMENT CYCLE
ADF Rubber	20,000 Pages
ADF Roller	60,000 Pages
Pick-up Roller	60,000 Pages
Friction Pad	60,000 Pages
Transfer Roller	60,000 Pages
Fuser	60,000 Pages
Toner Cartridge	3,500 Pages (A4 IDC 5% Pattern)

6.8 Abnormal Image Printing and Defective Roller

If abnormal image prints periodically, check the parts shown below.

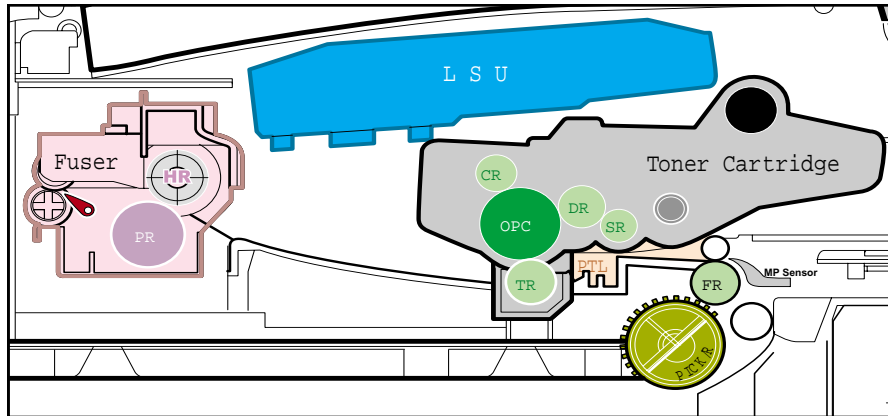

- | | |
|---------------------|-------------------|
| ① OPC Drum | ⑤ Transfer Roller |
| ② Charge Roller | ⑥ Heat Roller |
| ③ Supply Roller | ⑦ Pressure Roller |
| ④ Developing Roller | |

No	Roller	Abnormal image period	Kind of abnormal image
1	OPC Drum	75.5mm	White spot, Black spot
2	Charge Roller	37.7mm	Black spot
3	Supply Roller	37.0mm	Horizontal density band
4	Develop Roller	35.2mm	Horizontal density band
5	Transfer Roller	45.3mm	Black side contamination/transfer fault
6	Heat Roller	66.3mm	Black spot and fuser ghost
7	Pressure Roller	75.5mm	Black side contamination

6.9 Error Messages

The display on the front panel shows printer status and error messages. Refer to the following material for explanations of the messages and possible solutions to the problems. The messages are listed in alphabetical order, with numbered messages following.

BYPASS JAM

Meaning : The machine detected a non-feeding condition from the BYPASS Tray.

Solution : Open the side Cover and clear the jam.

COMM. ERROR

Meaning : A problem with the facsimile communications has occurred.

Solution : Try again.

DOCUMENT JAM

Meaning : Loaded document has jammed in the ADF.

Solution : Clear the document Jam.

DOOR OPEN

Meaning : The side cover is not securely latched.

Solution : Clear the cover until it clicks in place.

DRUM WARNING

Meaning : Nearing end of drum life, the machine page count has exceeded 14000 print pages.

Solution : Drum has 1,000 pages remaining. When the "REPLACE DRUM" message appears in the display, the drum must be replaced.

GROUP NOT AVAILABLE

Meaning : You have tried to select a group location where only a single location number can be used, such as when adding locations for a multi-dial operation.

Solution : Try again, check location for group.

Heating Error

Meaning : During operation, temperature does not go up.

Solution : Check thermister contact point & Heating Lamp.

LINE BUSY

Meaning : The remote FAX didn't answer

Solution : Try again.

LINE ERROR

Meaning : Your unit cannot connect with the remote machine, or has lost contact because of a problem on the phone line. When the machine has a problem in cause of fax data reception step

Solution : Try again. Try connecting a phone to the socket to check the line. If failure persists, wait an hour or so for the line to clear then try again.

LOAD DOCUMENT

Meaning : You have attempted to set up a sending operation with no document loaded.

Solution : Load a document and try again.

MEMORY FULL

Meaning : The memory has become full.

Solution : Either delete unnecessary documents, or retransmit after more memory becomes available, or split the transmission into more than one operation.

NO ANSWER

Meaning : The remote machine did not answer after all the redial attempts.

Solution : Try again. Make sure the remote machine is OK.

NO CARTRIDGE

Meaning : The machine has detected that no toner cartridge is installed.

Solution : Install the Cartridge.

NO. NOT ASSIGNED

Meaning : The speed dial location you tried to use has no number assigned to it.

Solution : Dial the number manually with the keypad, or assign the number.

NO PAPER [ADD PAPER]

Meaning : The paper tray is empty. The printer system stops.

Solution : Load new paper in the paper tray.

OPEN HEAT ERROR

Meaning : Thermister is not connected to main board or contact point is loose at power on.

Solution : Check thermister contact point, Heating Lamp & Thermostat.

OVERHEAT

Meaning : The printer has overheated.

Solution : Your unit will automatically return to the standby mode when it cools down to normal operating temperature. If failure persists, check the ELA HOU-FUSER.

PAPER JAM 0**OPEN/CLOSE DOOR**

Meaning : Paper has jammed in paper feeding area. Paper is jammed in pick-up unit

Solution : Press STOP and clear the jam.

PAPER JAM 1/2**OPEN/CLOSE DOOR**

Meaning : Paper has jammed inside the unit. Paper has jammed in paper exit unit.

Solution : Clear the jam.

RETRY REDIAL?

Meaning : The machine is waiting for the programmed interval to automatically redial.

Solution : You can press START to immediately redial, or STOP to cancel the redial operation.

TONER EMPTY

Meaning : When the machine has encountered the Toner Empty.

Solution : Replace the Toner Cartridge.

TONER LOW

Meaning : Toner may be low

Solution : Toner may be unevenly distributed. Remove the toner cartridge and shake it gently to evenly distribute the toner. Then replace the toner cartridge and retry.

Scanner Locked

Meaning : Scanner is locked by locker.

Solution : Check locker. Connect the Flat-Cable.

Memo

7. Troubleshooting

7.1 Paper Feeding Problems

7.1.1 Wrong Print Position

- **Description** Printing begins when the paper is in the wrong position.

Check and Cause	Solution
A defective feed sensor actuator can cause incorrect timing.	Replace the defective actuator

7.1.2 JAM 0

- **Description**
 1. Paper has not exited from the cassette.
 2. Jam-0 occurs if the paper feeds into the printer.

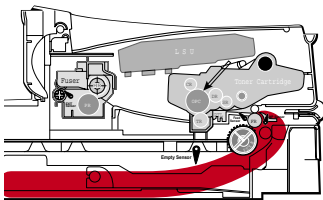

Check and Cause	Solution
1. Check the Solenoid by using Engine Test Mode : Diagnostic Mode code 0	1. Replace the solenoid.
2. Check if the pad is loose due to bad sealing of the side-pad.	2. Replace the side-pad Assembly L or R, if necessary.
3. Check the surface of the roller-pick-up for foreign matter.	3. Clean with soft cloth dampened with IPA(Isopropyl Alcohol) or water.
4. If the paper feeds into the printer and Jam 0 occurs, perform DCU to check feed-sensor of the engine board.	4. Replace the Housing-Pickup and/or Shaft-Pickup.

7.1.3 JAM 1

- **Description**
 1. Paper is jammed in front of or inside the fuser.
 2. Paper is stuck in the discharge roller and in the fuser just after passing through the Actuator-Feed.

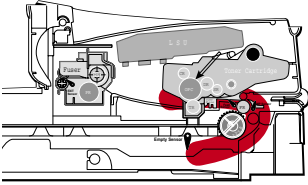

Check and Cause	Solution
<ol style="list-style-type: none"> 1. If the paper is jammed in front of or inside the fuser. 2. If the paper is stuck in the discharge roller and the fuser just after passing through the Actuator-Feed, Feed Actuator may be defective. 	<ol style="list-style-type: none"> 1. Replace the SMPS. 2. Reassemble the Actuator-Feed and Spring-Actuator.

7.1.4 JAM 2

- **Description**
 1. Paper exits the printer but Jam 2 occurs.
 2. Paper is stuck in the fuser roller.

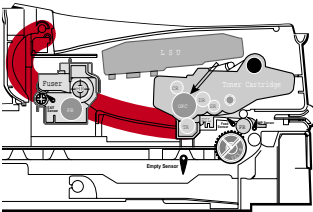

Check and Cause	Solution
<ol style="list-style-type: none"> 1. If the paper exits the printer completely but Jam 2 occurs <ul style="list-style-type: none"> • Exit sensor is defective. • After the paper is completely discharged, the Exit actuator should return to the original position to shut off the photo-sensor. 2. If the paper is rolled in the Fuser Roller: <ul style="list-style-type: none"> • This occurs when a Guide claw is broken away or distorted. • It occurs when the Heat-Roller or Pressure-Roller is seriously contaminated with toner. 3. Concertina paper jam in the fuser. 	<ol style="list-style-type: none"> 1. Check if the exit sensor actuator is defective. <ul style="list-style-type: none"> • Check if the actuator exit is distorted (Check if the lever part is distorted). Replace Actuator Exit. • Check whether burrs occur on the assembly part of the actuator exit and if the actuator operates smoothly. Replace Actuator Exit. • Check if foreign matters and wire are interfering with the operation of the actuator exit's. 2. If the paper is stuck in the fuser : disassemble the fuser and remove the jammed paper, and clean the surface of the pressure roller with dry gauze. 3. Remove the jammed paper after disassembling the fuser : Clean the surface of the pressure roller with dry gauze. <ul style="list-style-type: none"> • Remove the toner particles stained on the rib. • Check the assembly and performance of the exit.

7.1.5 Multi-Feeding

• **Description** Multiple sheets of paper are fed at once.

Check and Cause	Solution
1. Solenoid malfunction(the solenoid does not work properly): Perform Engine Test Mode : Diagnostic Mode code 0. 2. Friction-Pad is contaminated with foreign matter.(oil..) 3. Paper is curled.	1. Replace the solenoid if necessary. 2. Clean the friction-pad with soft cloth dampened with IPA(Isopropyl Alcohol). 3. Remove curled paper.

7.1.6 Paper rolled in the fuser

• **Description** If contaminated at intervals of 57mm on the back of a paper.

Check and Cause	Solution
1. Contamination of the pressure roller. (Background, Hot off set)	1. Disassemble the fuser, clean the area between the Heat-roller and and remove the foreign matter off of the pressure roller. 2. If background appears badly in the printing, fix it by referring to the solutions for background. (See 7.3.8 Background)

7.1.7 Paper rolled in the OPC

• **Description** Paper is rolled up in the OPC.

Check and Cause	Solution
<ol style="list-style-type: none"> 1. Paper is out of specification. 2. Paper is curled. 	<ol style="list-style-type: none"> 1. Use recommend paper. 2. How to remove the rolled paper in the OPC. <ul style="list-style-type: none"> • Remove the paper while turning the OPC against the ongoing direction. • Clean fingerprints on the OPC softly with soft cloth dampened with IPA(Isopropyl Alcohol) or tissue.

7.1.8 Defective ADF

• **Description** ADF (Automatic document Feeder) is not operating properly.

Check and Cause	Solution
<ol style="list-style-type: none"> 1. Check if ADF rubber and HOLDER rubber are damaged. 2. Check if the document sensors of ADF Ass'y (3 paper sensors) are normal. 	<ol style="list-style-type: none"> 1. Replace the contaminated or damaged part. 2. Replace the ADF ASS'Y.

7.2. Printing Problems (malfunction)

7.2.1 Defective Operation (LCD WINDOW ■■■) Display

- **Description** Strange characters are displayed on the OPE Panel and buttons do not operate.

Check and Cause	Solution
<ol style="list-style-type: none"> 1. Clear the memory.(see page 6.5.3) 2. Check if OPE Harness is connected to the Connection B'd correctly. 	<ol style="list-style-type: none"> 1. Try again after clearing the memory. 2. After confirming that OPE Harness is connected to the Connection B'd correctly, replacethe OPE Ass'y and Main Board in sequence.

7.2.2 Defective LCD Operation

- **Description** Defective LCD Operation

Check and Cause	Solution
<ol style="list-style-type: none"> 1. Clear the memory. (See page 6.4.3). 2. Confirm you can hear a click sound, while pressing a key on the OPE panel. 	<ol style="list-style-type: none"> 1. Disassemble and reassemble the OPE Ass'y. Replace defective part. 2. Replace the OPE Ass'y and the Main PBA in sequence.

7.2.3 Not functioning of the fuser gear due to melting away

• **Description** The fuser gear melts and breaks.

Check and Cause	Solution
1. Check the Heat Lamp.	1. Replace the Fuser. 2. Replace the Main PBA. 3. Replace the SMPS.

7.2.4 Paper Empty

• **Description** The paper lamp on the operator panel is on even when paper is loaded in the cassette.

Check and Cause	Solution
1. Bending or deformation of the actuator of the paper sensor.	1. Replace the defective actuator.
2. The function of the Main PBA is defective Perform Engine Test Mode : Perform Engine Test Mode diagnostic code 2.	2. Replace the Main PBA.

7.2.5 Paper Empty without indication

• **Description** The paper lamp on the operator panel does not come on when the paper cassette is empty.

Check and Cause	Solution
1. Bending or deformation of the actuator of the paper sensor.	1. Replace the defective actuator.
2. The function of the Main PBA is defective Perform Engine Test Mode : Perform Engine Test Mode diagnostic code 2.	2. Replace the Main PBA.

7.2.6 Door Open

• **Description** The ERROR lamp is on even when the print Door is closed.

Check and Cause	Solution
1. The hook lever in the Front Cover may be defective. 2. Check the Connector(CN1) and Circuit of the Cover Switch department in the Main PBA.	1. Replace the hook lever, if defective. 2. Check the insertion of the Door Open S/W Connect. 3. Replace the Main PBA or Door Open S/W.

7.2.7 No lamp on when the Door is open

• **Description** The ERROR lamp does not come on even when the printer Door is open.

Check and Cause	Solution
Check the Connector(CN1) and Circuit of the Cover Switch department in the Main PBA.	1. Check the insertion of the Door S/W Connect. 2. Replace the Main PBA or Door Open S/W.

7.2.8 Defective Motor operation

• **Description** Main Motor is not driving when printing, and paper does not feed into the printer, resulting 'Jam 0'.

Check and Cause	Solution
1. Motor harness may be defective. 2. Perform Engine Test Mode diagnostic code 0 and Check the Motor operation.	1. Check the Motor harness, replace it, if defective. 2. Replace the SMPS or Main Board, if necessary.

7.2.9 No Power

• **Description** When system power is turned on, all lamps on the operator panel do not come on.

Check and Cause	Solution
1. Check if the power input and SMPS output are normal. 2. Check inside the LED-Panel on the front-cover, if the LED-Panel does not appear after normal warm-up.	1. Replace the power supply cord or SMPS. 2. Replace the control board. 3. Replace the LED-panel.

7.2.10 Vertical Line Getting Curved

- **Description** When printing, vertical line gets curved.

Check and Cause	Solution
1. If the supply of +24v is unstable in the Main Control board linking with LSU, check drive by Engine Test Mode : Diagnostic Code 1 LSU Motor on.	1. Replace LSU. 2. Replace the Main Control board.

7.3 Printing Quality Problems

7.3.1 Vertical Black Line and Band

- **Description**
 1. Straight thin black vertical line occurs in the printing.
 2. Dark black vertical band occurs in the printing.

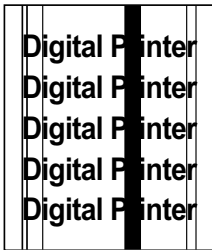

Check and Cause	Solution
<ol style="list-style-type: none"> 1. Damaged developer roller in the developer. Deformed Doctor-blade or cleaning-blade. 2. Scratched surface of the discharge roller in the developer. 3. Partial depression or deformation on the surface of the transfer roller. 	<ol style="list-style-type: none"> 1. If causes 1 and 2 occur in the developer cartridge, replace the developer and try to print out. 2. Replace the transfer roller if occurred as No. 3.

7.3.2 Vertical White Line

- **Description** White vertical voids in the image.

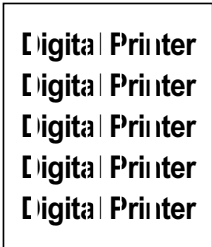

Check and Cause	Solution
<ol style="list-style-type: none"> 1. Foreign matter stuck onto the window or internal lenses of LSU mirror. 2. Foreign matter or toner particles between the developer roller and blade. (In case the life of the developer has expired, white lines or light image occur in front of the image.) 3. It may occur when a burr and foreign substances are on the window of the developer frame. 4. If the fuser is defective, voids occur periodically at the top of a black image. 	<ol style="list-style-type: none"> 1. Foreign matter stuck onto the window : Clean the LSU window with recommended cleaner(IPA) Clean the window with a clean cotton swab. 2. Foreign matter in the LSU : Open the cover of LSU and clean with a cotton swab on the surface of the reflex mirror. 3. Remove the foreign matter and burr of the exposure window. (Developer cartridge) 4. Open the front cover and check that the ribs corresponds to the position of the lines. 5. If the problems are not solved, replace the developer cartridge.

7.3.3 Horizontal Black Band

- **Description** 1. Dark or blurry horizontal stripes occur in the printing periodically.
(They may not occur periodically.)



Check and Cause	Solution
1. Bad contact of the voltage terminals to developer. 2. The rollers of developer may be stained. Charge roller = 37.7 mm Supply roller = 37 mm Develop roller = 35.3 mm Transfer roller = 45.3 mm	1. Clean each voltage terminal of the Charge, Supply, Develop and Transfer roller. (remove the toner particles and paper particles) 2. Measure the interval of the black bands, refer to the measurements shown opposite and clean the appropriate gear in the OPC. 3. If the malfunction persists, replace the developer.

7.3.4 Black/White Spot

- **Description** 1. Dark or blurry black spots occur periodically in the printing.
2. White spots occur periodically in the printing.



Check and Cause	Solution
1. If dark or blurry black spots occur periodically, the rollers in the Developer may be contaminated with foreign matter or paper particles. (Charge roller : 37.7 mm interval OPC drum : 75.5 mm interval) 2. If faded areas or voids occur in a black image at intervals of 75.5 mm, or black spots occur elsewhere, the OPC drum surface is damaged. 3. If a black image is partially broken, the transfer voltage is abnormal or the transfer roller's life has expired.	1. Run OPC cleaning Mode Print and run the Self-test 2 or 3 times. 2. In case of 75.5 mm interval unremovable in 1, remove any foreign substances stuck on the OPC location equivalent to black spots and white spots with a dry duster. 3. The transfer roller guarantees 60,000 sheets printing. If the roller's life is expired, replace it. 4. In case of 37.7 mm interval not removable in 1, replace the developer cartridge and try to print out. 5. Clean paper particles and foreign matter from the inside of the machine.

7.3.5 Light Image

• **Description** The printed image is light, with no ghost.

Digital Printer
 Digital Printer
 Digital Printer
 Digital Printer
 Digital Printer

Check and Cause	Solution
1. Developer roller is stained when the toner is almost used up.	1. Check if the Toner Save Mode is off.
2. Ambient temperature is below than 10°C.	2. No 1 : Replace the developer cartridge and try to print out.
3. Bad contact caused by the toner stains between the high voltage terminal in the HVPS and the one in the set.	3. No 2 : Wait 30 minutes after printer is powered on before you start printing.
4. Abnormal output from the HVPS. (Run self-test and check 1~4)	4. No 3 : Clean up the contaminated area by the toner.
	5. Replace the HVPS if the problems are not solved by the above four directions.

7.3.6 Dark Image or a Black

• **Description** The printed image is dark.

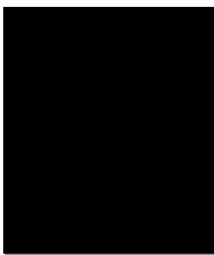

Check and Cause	Solution
1. No charge voltage in the Main PBA. (Perform Engine Test Mode : Diagnostic code 4 HVPS check.)	1. Clean the high voltage charge terminal.
2. Charge voltage is not turned on due to the bad contacts between power supply in the side of the Developer and charge terminal of HVPS.	2. Check the state of the connector which connects the engine board and HVPS.
	3. If steps 1 and 2 above did not correct the problem, replace the HVPS .

7.3.7 Uneven Density

• **Description** Print density is uneven between left and right.

Digital Printer
 Digital Printer
 Digital Printer
 Digital Printer
 Digital Printer

Check and Cause	Solution
1. The pressure force on the left and right springs of the transfer roller is not even, the springs are damaged, the transfer roller is improperly installed, or the transfer roller bushing or holder is damaged.	1. Replace both the left and right Spring Holder.
2. The life of the Toner Unit has expired.	2. Problem with the toner cartridge, replace the toner cartridge and try to print out.
3. The toner level is not even on the developer roller due to the bad blade.	

7.3.8 Background

• **Description** Background appears in whole area of the printing.

Digital Printer
 Digital Printer
 Digital Printer
 Digital Printer
 Digital Printer

Check and Cause	Solution
1. Recycled recording paper has been used.	1. Quality is not guaranteed when using recycled paper.
2. The life of the Developer has expired.	2. Replace the toner cartridge.
3. The vertical movement of the transfer roller is too great?	3. Clean the bush part of the transfer roller.
4. The HVPS is normal? (Perform Engine Test Mode diagnostic code 4)	4. Replace the HVPS.

7.3.9 Ghost (1)

• **Description** Ghost occurs at 75.5 mm intervals of the OPC drum in the whole printing.



Check and Cause	Solution
1. Bad contacts caused by contamination from toner particles between high voltage terminal in the main body and the electrode of the Toner Unit.	1. Clean the contaminated terminals.
2. Bad contacts caused by contamination from toner particles between high voltage terminal in the main body and the one in the HVPS board.	2. Problem in the toner cartridge, replace the toner cartridge and try to print out.
3. The life of Toner Unit has expired.	3. Replace the engine board if not solved by the above Steps 1 and 2.
4. Transfer roller lifetime (60,000 sheets) has expired.	4. If not solved by Step 3, check the transfer roller lifetime and replace it.
5. Abnormal low temperature (below 10°C).	5. Wait about 30 minutes after power on before using printer.
6. Damaged cleaning blade in the Toner Unit.	6. Problem in the toner cartridge, replace the toner cartridge and try to print out.

7.3.10 Ghost (2)

• **Description** Ghost occurs at 75 mm intervals of the OPC drum in the whole printing. (When printing on card stock or transparencies using manual feeder)



Check and Cause	Solution
When printing on card stock thicker than normal paper or transparencies such as OHP, higher transfer voltage is required.	Select 'Thick Mode' on paper type menu from the software application and after use, we recommend returning to the original Mode.

7.3.11 Ghost (3)

• **Description** White ghost occurs in the black image printing at 32 mm intervals.



Check and Cause	Solution
<ol style="list-style-type: none"> 1. The life of Toner Unit has expired. 2. The abnormal voltage and bad contact of the terminal of the supply roller 	<ol style="list-style-type: none"> 1. Problem in the toner cartridge, replace the toner cartridge and try to print out. 2. Replace the SMPS PBA.

7.3.12 Ghost (4)

• **Description** Ghost occurs at 64 mm intervals.



Check and Cause	Solution
<p>Check if the Thermistor is connected correctly..</p>	<ol style="list-style-type: none"> 1. Disassemble the fuser and remove the contaminated toner particles on the roller and clean the foreign matter between Thermistor and Heat roller. (▲ Caution: can be deformed)

7.3.13 Stains on the front of the page

• **Description** The background on the face of the printed page is stained.



Check and Cause	Solution
<ol style="list-style-type: none"> 1. Toner leakage due to improperly sealed developer. 2. If the transfer roller is contaminated, stains will occur on the front of the page. 	<ol style="list-style-type: none"> 1. Replace the toner cartridge. 2. If the transfer roller is contaminated, run PC Cleaning Mode Print 2 or 3 times. And perform Self-Test 2 or 3 times to remove contamination. 3. Replace the Transfer Roller..

7.3.14 Stains on back of the page

• **Description** The back of the page is stained at 56.1 mm intervals.

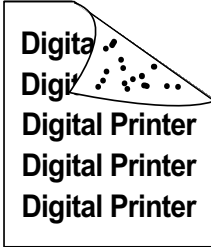

Check and Cause	Solution
1. Transfer roller is contaminated.	1. Perform the OPC Cleaning Mode Print 2 or 3 times. Run Self-Test to remove the contamination of the transfer roller.
2. Pressure roller is contaminated.	2. Replace the transfer roller if contaminated severely.
	3. Disassemble the fuser and clean the H/R(Heat Roller) and P/R(Pressure roller). Check the area between H/R and Thermistor. If contaminated, clean the area. Replace the contaminated part.

7.3.15 Blank Page Print out (1)

• **Description** Blank page is printed.



Check and Cause	Solution
Bad ground contacts in OPC and/or developer.	Clean the terminals of the toner cartridge and the printer.

7.3.16 Blank Page Print out (2)

• **Description**

1. Blank page is printed.
2. One or several blank pages are printed.
3. When the printer turns on, several blank pages print.

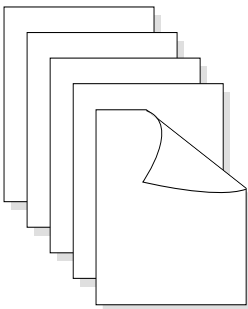

Check and Cause	Solution
1. Bad ground contacts in OPC and/or developer.	1. Clean the terminals of the toner cartridge.
2. The Pick-up Solenoid is not working correctly.	2. Perform the engine self test using Engine Test Mode diagnostic Mode code 0 if the Pick-up Solenoid is normal.
	3. If not solved by the Steps1-2, replace the engine board.
	4. Turn the power off, clear the print job on the computer, and try printing again.

7.4 Fax & Phone Problems

7.4.1 No Dial Tone

- **Description** While on-hook button is pressed, there is no dial tone.

Check and Cause	Solution
<ol style="list-style-type: none"> 1. Check if the telephone line cord is connected to TEL LINE correctly. 2. Check if it makes CLICK sound while OHD key is pressed. 3. Check the connection of HARNESS between the LIU and the Main PBA. 4. Check if the SPEAKER is connected correctly. 	<ol style="list-style-type: none"> 1. If the telephone cord is normal but there is no dial tone, connect a phone to check for a dial tone, if no dial tone, replace the LIU PBA. 2. If you cannot hear the OHD CLICK sound, the OPE ASS'Y may be defective. Replace the OPE ASS'Y. 3. Check the connection of Speaker, and replace it. 4. If the problem still persists, replace the Main PBA.

7.4.2 Defective MF DIAL

- **Description** The MF DIAL is not functioning.

Check and Cause	Solution
<ol style="list-style-type: none"> 1. Check if the telephone line is connected correctly. 2. While the BUTTON KEY is pressed, check for a CLICK sound. 3. Check the connection of HARNESS between the LIU and the Main PBA. 	<ol style="list-style-type: none"> 1. If you cannot hear the OHD CLICK sound, the OPE ASS'Y may be defective. Replace the OPE ASS'Y. 2. If you can hear a CLICK sound, after checking the connection of harness between the LIU and the Main PBA, replace the harness. 3. If the problem still persists, replace the LIU and the Main PBA in that order. <p>Notes: Product supports the MF DIAL type only.</p>

7.4.3 Defective FAX SEND/RECEIVE

- **Description** The FAX SEND/RECEIVE is not functioning.

Check and Cause	Solution
<ol style="list-style-type: none"> 1. Check if you can get a dial tone by pressing OHD. 2. Check if you can hear a RECEIVE tone while MODEM testing in the TECH mode. 	<ol style="list-style-type: none"> 1. If the MODEM testing is normal and there is no dial tone, replace the LIU PBA. 2. If the MODEM testing is not normal, replace the Main PBA.

7.4.4 Defective FAX SEND

- **Description** RECEIVE is functioning, but SEND is not functioning or the received data are broken.

Check and Cause	Solution
<ol style="list-style-type: none"> 1. Check if there is noise when pressing on-hook dial. 2. Check the RECEIVE condition by trying to send a FAX to another fax machine from the sending FAX. 3. Check if the telephone line is connected to the product. Check if it has excessive noise. 	<ol style="list-style-type: none"> 1. If noise is present while on-hooking, replace the telephone line cord.

7.4.5 Defective FAX RECEIVE (1)

• **Description** SEND is functioning, but RECEIVE is not functioning or the received data are broken.

Check and Cause	Solution
<ol style="list-style-type: none"> 1. Check if there is NOISE when pressing on-hook dial. 2. Check the RECEIVE condition by receive a FAX at another fax machine. 	<ol style="list-style-type: none"> 1. If NOISE is present while on-hooking, replace the telephone line cord.

7.4.6 Defective FAX RECEIVE (2)

• **Description** The received data are lengthened or cut in the printing.

Check and Cause	Solution
<ol style="list-style-type: none"> 1. Check if there is noise when pressing on-hook dial. 2. Ask to the sending side, to check the image quality of a FAX received from another machine. 	<ol style="list-style-type: none"> 1. If noise is present, replace the telephone line cord. (Refer to 'Defective FAX RECEIVE'.) 2. Check if the FAX status of the sending side is normal.

7.4.7 Defective FAX RECEIVE (3)

• **Description** The phone is ringing continuously, but it cannot receive.

Check and Cause	Solution
<p>Check if the RECEIVE Mode is TEL MODE or FAX MODE.</p>	<p>After the RECEIVE mode is changed to FAX MODE, if it cannot receive, replace the LIU PBA and the Main PBA in sequence.</p>

7.4.8 Defective FAX RECEIVE (4)

- **Description** The received data is reduced by more than 50% in the printing.

Check and Cause	Solution
<p>Check the FAX status of the sending side.</p>	<p>After checking the data of the sending side, correct the FAX of the sending side.</p>

7.4.9 Defective Automatic Receiving

- **Description** The automatic receiving function is not working.

Check and Cause	Solution
<p>1. Check if the RECEIVE Mode is TEL MODE or FAX MODE.</p>	<p>1. If the RECEIVE Mode is set to the TEL MODE, reset it to the FAX MODE.</p> <p>2. After the RECEIVE mode is changed to FAX MODE, if it cannot receive, replace the LIU PBA and the Main PBA in sequence.</p>

7.5 Copy Problems

7.5.1 White Copy

- **Description** Blank page is printed out when copying.

Check and Cause	Solution
<ol style="list-style-type: none"> 1. Ensure that the Scan-Cover is closed. 2. Check shading profile. 3. Check white/black reference voltage in the Main PBA. 	<ol style="list-style-type: none"> 1. Exposing the drum to direct light for more than a few minutes can cause blank images. 2. Remake shading profile in the tech mode. 3. Replace the Main PBA.

7.5.2 Black Copy

- **Description** Black page is printed out when Copying.

Check and Cause	Solution
<ol style="list-style-type: none"> 1. Check the CCD problem in Main PBA. 2. Check shading profile. 	<ol style="list-style-type: none"> 1. Check the CCD harness contact. 2. Remake shading profile in the tech mode.

7.5.3 Abnormal noise

- **Description** There is noise when copying.

Check and Cause	Solution
<ol style="list-style-type: none"> 1. Check the Scanner Motor and for any mechanical damage. 2. Check the Motor Driver in Driver PBA. 	<ol style="list-style-type: none"> 1. Ensure that the Scanner Motor is correctly positioned, and check for any mechanical damage in the CCD carriage components. 2. If any driver is defective, replace it. <ul style="list-style-type: none"> • Connection PBA U4-1, 19 or U5-1, 19=0V to 24V swing signal when operating.

7.5.4 Defective Image Quality

- **Description** The copied image is light or bad.

Check and Cause	Solution
<ol style="list-style-type: none"> 1. Check shading profile. 2. Check the gap between original and scanner glass. 3. Check printing quality. 	<ol style="list-style-type: none"> 1. Remake shading profile in the Tech Mode. 2. A gap exceeding 0.5 mm can cause a blurred image. 3. See "Printing Quality Problems".

7.6 Scanning Problems

7.6.1 Defective PC Scan

- **Description** The PC Scan is not functioning at all.

Check and Cause	Solution
<ol style="list-style-type: none"> 1. Check the Cable (USB or Parallel) 2. Check if the driver is installed properly. 3. Check if copy function operates normally. 	<ol style="list-style-type: none"> 1. If the PC and the cable are not connected properly, reconnect the cable. 2. Perform a PC printing test to confirm proper driver installation and setup. If test fails, reinstall the driver. (Refer to User's Manual.) 3. If copy function works, replace the Main PBA. If copy function doesn't work, replace the CCD Ass'y and try again.

7.6.2 Defective Image Quality of PC Scan

- **Description** The image PC scanned is not clear or bad.

Check and Cause	Solution
<ol style="list-style-type: none"> 1. Check the waveform form by performing a CCD test in Tech Mode. 2. Check if the resolution is set too low in PC Scan options. (Refer to User's Manual.) 	<ol style="list-style-type: none"> 1. If the CCD waveform form is abnormal, try to replace the CCD Ass'y. 2. If the resolution is set too low, refer the user to the User's Manual.

7.7 Toner Cartridge Service

This product should only be used with Xerox Toner Cartridges specified in this document and the User Manual.

7.7.1 Precautions on Safe-keeping of Toner Cartridge

Exposure to direct light for more than a few minutes may cause damage to the cartridge.

7.7.2 Service for the Life of Toner Cartridge

If the printed image is light due to low toner level, you can temporarily improve the print quality by redistributing the toner (Shake the toner cartridge), however, you should replace the toner cartridge to solve the problem.

7.7.2.1 Redistributing Toner

When the toner cartridge is near the end of its life, white streaks or light print occurs. The LCD displays the warning message, "Toner Low." You can temporarily reestablish the print quality by redistributing the remaining toner in the cartridge.

1. Open the Front Cover.

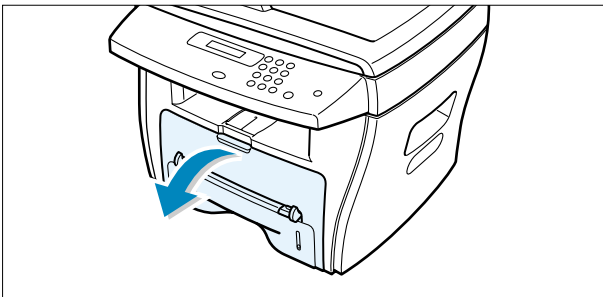

2. Lightly push down on the used cartridge and pull it out.

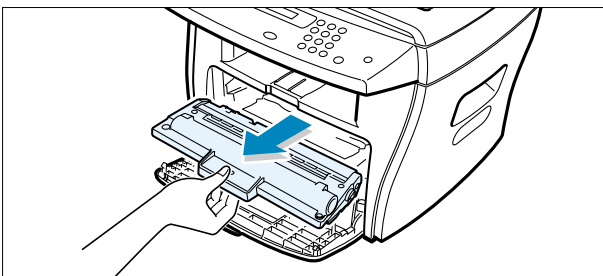

Note : Help the environment by recycling your used toner cartridge. Refer to the recycling brochure packed with the toner cartridge for details.

3. Unpack the new toner cartridge and gently shake it horizontally four or five times to distribute the toner evenly inside the cartridge.

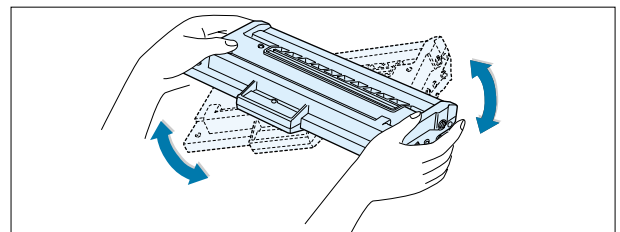

4. Save the box and the cover for shipping. Slide the new toner cartridge in until it locks into place.

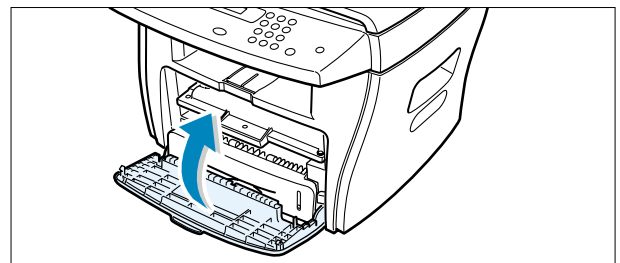

5. Close the front cover.

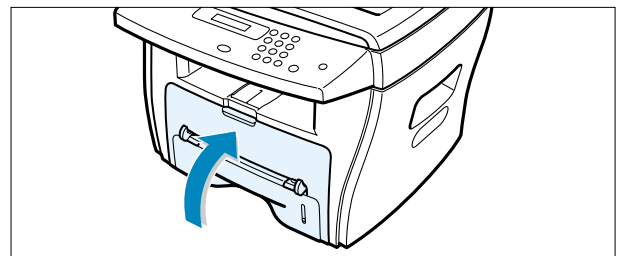

7.7.3 Signs and Measures at Poor toner cartridge

Fault	Signs	Cause & Check	Solution
<p>Light image and partially blank image (The life is ended.)</p>	<ul style="list-style-type: none"> • The printed image is light or unclean and untidy. • Some part of the image is not printed. • Periodically a noise as "tick tick" occurs. 	<ol style="list-style-type: none"> 1. If the image is light or unclean and untidy printed image - Shake the toner cartridge and then recheck. <ul style="list-style-type: none"> • Replace the Toner Cartridge 2. Some part of image is not printed - Shake the toner cartridge and then recheck. <ul style="list-style-type: none"> • NG : Clean the LSU window with a cotton swab, then recheck. • Replace the Toner Cartridge. 3. Periodically a noise as "tick tick" occurs - Measure the cycle. 4. White vertical stripes on the whole screen or partly. 	<ol style="list-style-type: none"> 1. All of 1, 2, 3 <ol style="list-style-type: none"> (1) If image quality improves after shaking, replace toner cartridge after 50-100 sheets in the closing state of the life span. 2. In case of 2- If it becomes better after cleaning the LSU window, then the toner cartridge is normal. (Because of foreign substance on the LSU window, part of the image has not been printed.) 3. In case of 3- If the cycle of noise is about 2 seconds, the toner inside the toner cartridge has been nearly exhausted. (Purchase and replace with a new toner cartridge after using about 200 sheets at the point of occurrence) 4. In case of 4- This is a condition is caused by lack of toner, so replace with a new toner cartridge.
<p>Toner Contamination</p>	<ul style="list-style-type: none"> • Toner falls on the papers periodically. • Contaminated with toner on prints partly or over the whole surface. 	<ol style="list-style-type: none"> 1. Toner falls on the paper periodically. <ol style="list-style-type: none"> (1)Check the cycle of falling toner. (2)Check the appearance of both ends of the toner cartridge. 2.The center of the printed matter is contaminated with toner. <ol style="list-style-type: none"> (1)Check whether foreign substances or toner are stuck to the terminal (contact point) of the toner cartridge. (2)Check whether the state of the terminal assembly is normal. 	<ol style="list-style-type: none"> 1. If both ends of the OPC drum are contaminated with toner: Try to remove the contamination with a soft cloth. 2. Replace the toner cartridge.

Fault	Signs	Cause & Check	Solution
<p>White/Black spot</p>	<ul style="list-style-type: none"> • Light or dark black dots on the image occur periodically. • White spots occur in the image periodically. 	<ol style="list-style-type: none"> 1. If light or dark black dots occur periodically, it is because the developer rollers are contaminated with foreign substance or paper particles. <ul style="list-style-type: none"> (1) 37.7 mm interval : Charge roller (2) 75.5 mm interval : OPC cycle 2. If white spots occur in a black image at intervals of 75mm, or black spots occur elsewhere, the OPC drum is damaged or foreign substance is stuck to the surface. 3. If a black and white or graphic image is partially broken at irregular intervals, the transfer roller's life has expired or the transfer voltage is abnormal. 	<ol style="list-style-type: none"> 1. In case of 1 above - <ul style="list-style-type: none"> Run OPC Cleaning Mode Print 4-5 times repeatedly to remove. Especially check foreign substance on the OPC surface, then remove it with a clean gauze moistened with IPA (Isopropyl Alcohol) take care not to damage the OPC. 2. In case of 2 <ul style="list-style-type: none"> Run the OPC Cleaning Mode Print 4-5 times to remove the contaminants. : at intervals of 37mm - Replace the toner cartridge. : at intervals of 75.5 mm - Remove foreign substance. : Broken image - Replace the toner cartridge. 3. In case of 3 - <ul style="list-style-type: none"> Exchange the transfer roller because the life of the transfer roller has been exceeded. (Exchange the SMPS PBA)

Fault	Signs	Cause & Check	Solution
<p>Ghost & Image Contamination</p>	<ul style="list-style-type: none"> • The printed image is too light or dark, or partially contaminated black. • Totally contaminated black. (Black image printed out) • The density of print-outs is too dark and ghost occurs. 	<ol style="list-style-type: none"> 1. The printed image is too light or dark, or partially contaminated black. <ol style="list-style-type: none"> (1) Check whether foreign substance or toner are stuck to the terminal (contact point) of the toner cartridge. (2) Check whether the terminal assembly is damaged. 2. Totally contaminated black. (Black image printed out) <ol style="list-style-type: none"> (1) Check for foreign substances stuck to the terminal (contact point) of the developer and for damage to the assembly. (Especially check the charge roller terminal.) 3. The printed image is dark and ghost occurs. <ol style="list-style-type: none"> (1) Check for foreign substance on the terminal (point of contact) of the developer and for damage to the assembly. (Especially check the developing roller terminal.) 	<ol style="list-style-type: none"> 1. All of 1, 2, 3 above <ol style="list-style-type: none"> (1) Remove toner and foreign substances on the contacts of the developer. (2) The contacts of the unit facing the developer must also be cleaned. (3) If the terminal assembly is damaged: Replace the broken part. 2. In case of 2 It is a condition, when the OPC drum of the toner cartridge is not electrically charged. 3. In case of 3 It is a condition of the developer bias voltage. Clean the terminals of the developing roller, then recheck it.

Memo

8. Exploded Views and Parts List

8.1 Main Assembly Exploded view	page(8-2)
8.2 Rx Drive Ass'y Exploded view	page(8-5)
8.3 ADF Assembly Exploded view	page(8-6)
8.4 OPE Assembly Exploded view	page(8-10)
8.5 Scanner Assembly Exploded view	page(8-12)
8.6 Middle Cover Assembly Exploded view	page(8-14)
8.7 Frame Ass'y Exploded view	page(8-15)
8.8 Fuser Ass'y Exploded view	page(8-18)
8.9 Cassette Ass'y Exploded view	page(8-20)

8.1 Main Assembly

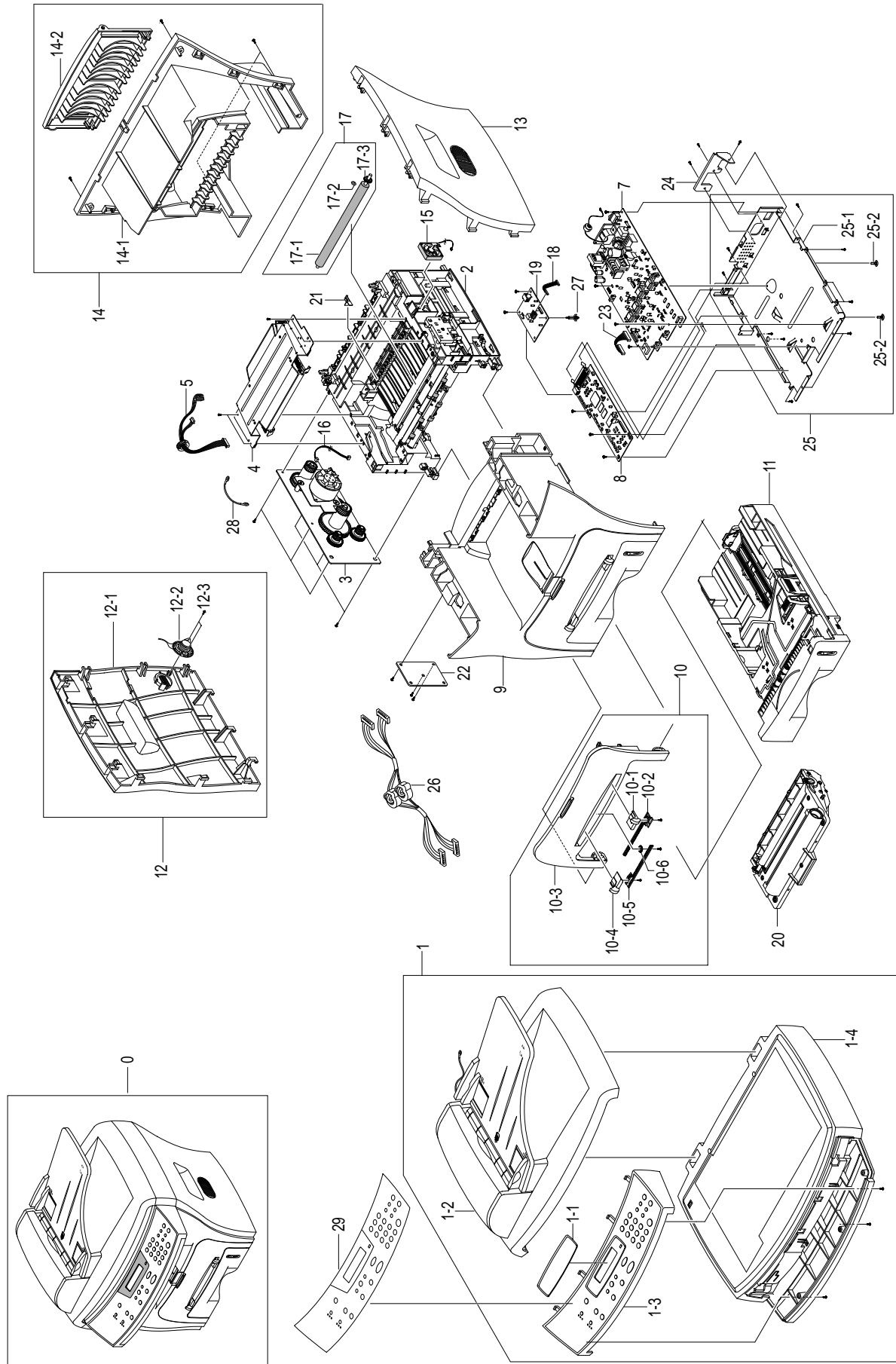

Main Assembly Parts List

No.	Description	Part Number	Q'ty	Remark
0	WorkCentre PE16			
1	ELA HOU-UNIT SCAN	500 N 00105	1	
1-1	COVER-LCD WINDOW	*	1	Not Spared
1-2	ELA HOU-ADF	101 N 01337	1	
1-3	AS-ELA HOU-OPE(XEROX)	101 N 01338	1	
1-4	ELA HOU-PLATEN	101 N 01339	1	
2	ELA HOU-UNIT FRAME_110V	001 N 00407	1	110V
	ELA HOU-UNIT FRAME_220V	001 N 00408	1	220V
3	ELA UNIT-RX DRIVE	126 N 00211	1	
4	UNIT-LSU	122 N 00228	1	
5	CBF HARNESS-LSU	152 N 02010	1	
7	SMPS-SMPS(V1)+HVPS	105 N 02005	1	110V
	SMPS-SMPS(V2)+HVPS	105 N 02006	1	220V
8	PBA MAIN-MAIN	140 N 62743	1	
9	MEA UNIT-COVER MIDDLE	101 N 01334	1	
10	MEA UNIT-COVER FRONT(XEROX)	101 N 01335	1	
10-1	ADJUST-M-MANUAL_R	*	1	Not Spared
10-2	ADJUST RACK-M-MANUAL	*	2	Not Spared
10-3	COVER-M_FRONT(ROCKY)	*	1	Not Spared
10-4	ADJUST-M-MANUAL_L	*	1	Not Spared
10-5	GEAR-RACK_PINION	*	1	Not Spared
11	MEA UNIT-CASSETTE, USA	050 N 00427	1	
12	ELA HOU-COVER SIDE L	101 N 01336	1	
12-1	COVER-M-SIDE L	*	1	Not Spared
12-2	SPEAKER	*	1	Not Spared
12-3	SCREW-TAPTITE	*	2	Not Spared
13	COVER-M-SIDE R	002 N 02191	1	
14	MEA UNIT-COVER REAR	002 N 02192	1	
14-1	COVER-M-REAR	*	1	Not Spared
14-2	COVER-M-FACE UP	*	1	Not Spared
15	FAN-DC	127 N 01453	1	
16	CBF HARNESS-MOTOR	152 N 02009	1	
17	MEA ETC-TR	022 N 01606	1	
17-1	ROLLER-TRANSFER ROLLER	022 N 02017	1	
17-2	GEAR-TRANSFER	*	1	Not Spared
17-3	PPR-SPACER_TR	*	1	Not Spared

Main Assembly Parts List(cont.)

No.	Description	Part Number	Q'ty	Remark
18	CBF SIGNAL-LIU	140 N 62744	1	
19	PBA-LIU_USA/CANADA	140 N 62758	1	
	PBA-LIU_WESTERN EUROPE	140 N 62745	1	
	PBA-LIU_RUSSIA	140 N 62759	1	
	PBA-LIU_SOUTH AFRICA	140 N 62760	1	
20	ELA-TONER UNIT	*	1	Not Spared
21	PLATE-P-CHANNEL	015 N 00495	1	
22	PBA SUB-CONN	140 N 62750	1	
23	CBF HARNESS-ENGINE	152 N 02012	1	
24	"BRACKET-P-INLET, ROCKY"	030 N 00654	1	
25	MEA UNIT-SHIELD ENGINE	055 N 00277	1	
25-1	"SHIELD-ENGINE, ROCKY"	*	1	Not Spared
25-2	SUPPORTER	*	2	Not Spared
26	CBF HARNESS-SCAN	152 N 11462	1	
27	SUPPORTER	030 N 00655	1	
28	CBF-HARNESS-DUPLEX GND	152 N 11463	1	
29	SHEET-OVERLAY(XEROX)	002 N 02194	1	

8.2 RX Drive Assembly

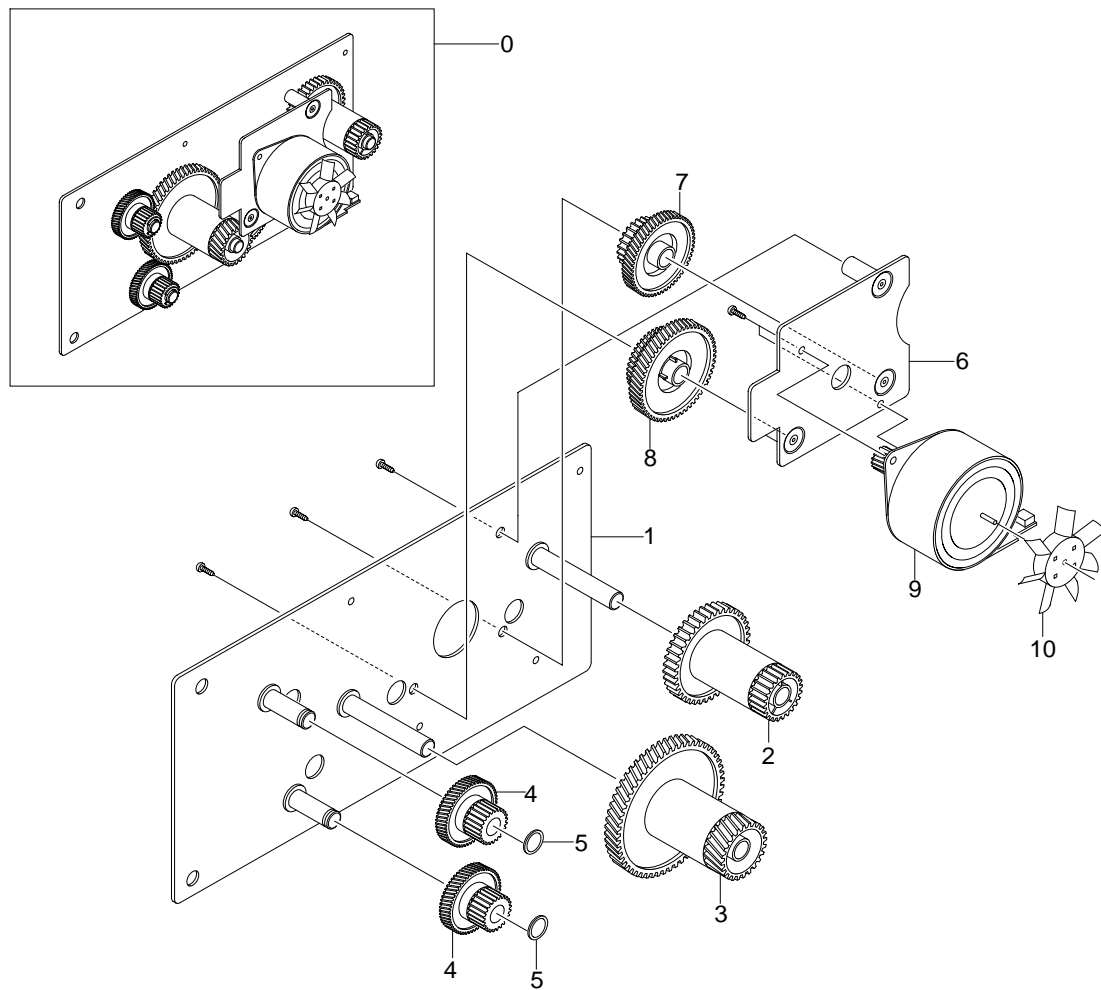

RX Drive Assembly Parts List

No.	Description	Part Number	Q'ty	Remark
0	ELA UNIT-RX DRIVE	126 N 00211	1	
1	BRACKET-P-GEAR 1400	*	1	Not Spared
2	GEAR-RDCN 53/26	*	1	Not Spared
3	GEAR-RDCN 113/33	*	1	Not Spared
4	GEAR-RDCN 57/18	*	2	Not Spared
5	WASHER-PLAIN	*	2	Not Spared
6	BRACKET-P-MOTOR 1400	*	1	Not Spared
7	GEAR-RDCN 103/41	*	1	Not Spared
8	GEAR-RDCN 90/31	*	1	Not Spared
9	MOTOR STEP-HUMMINGBIRD	*	1	Not Spared
10	PMO-IMPELLER_DRV	*	1	Not Spared

8.3 ADF Assembly

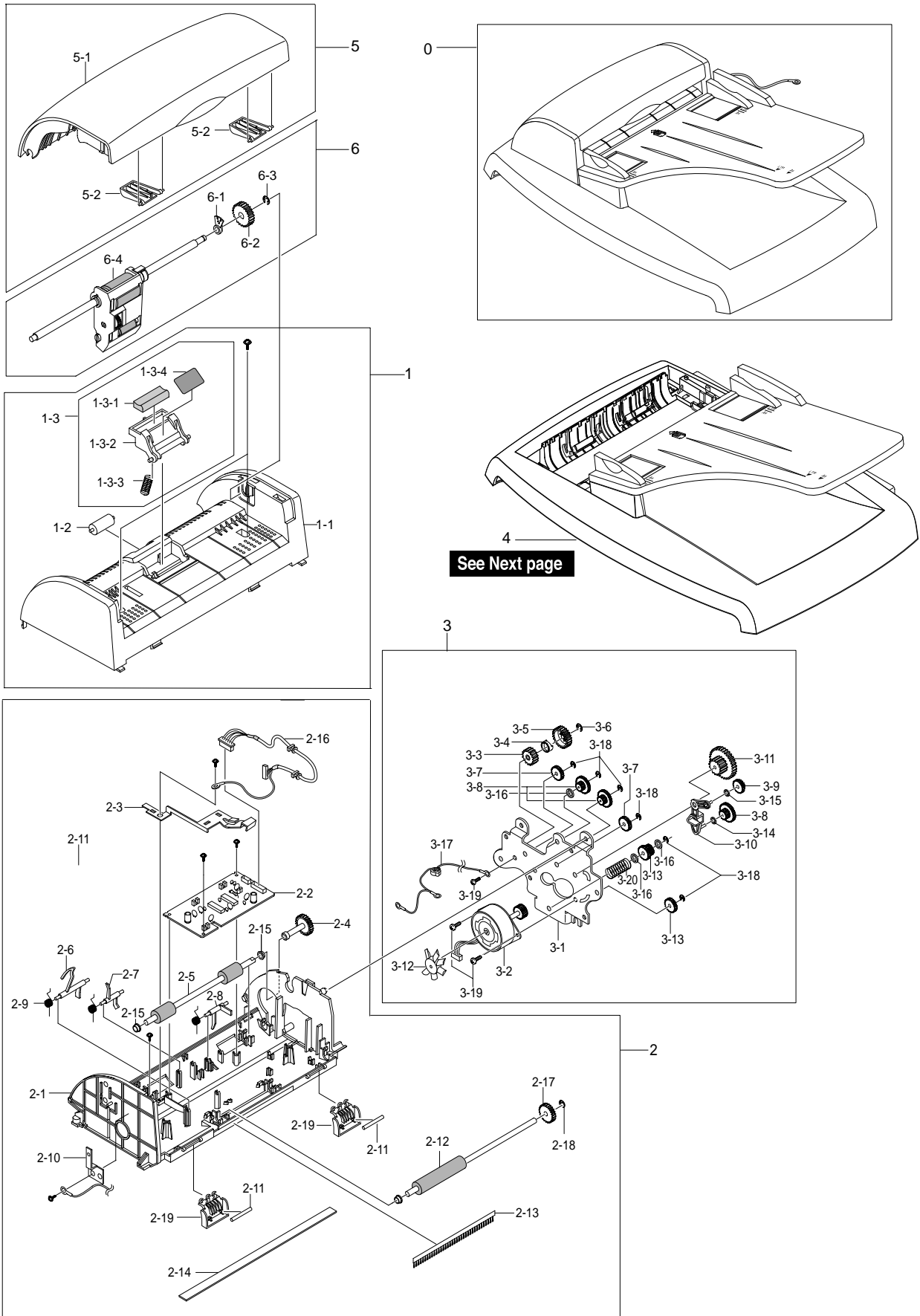

See Next page

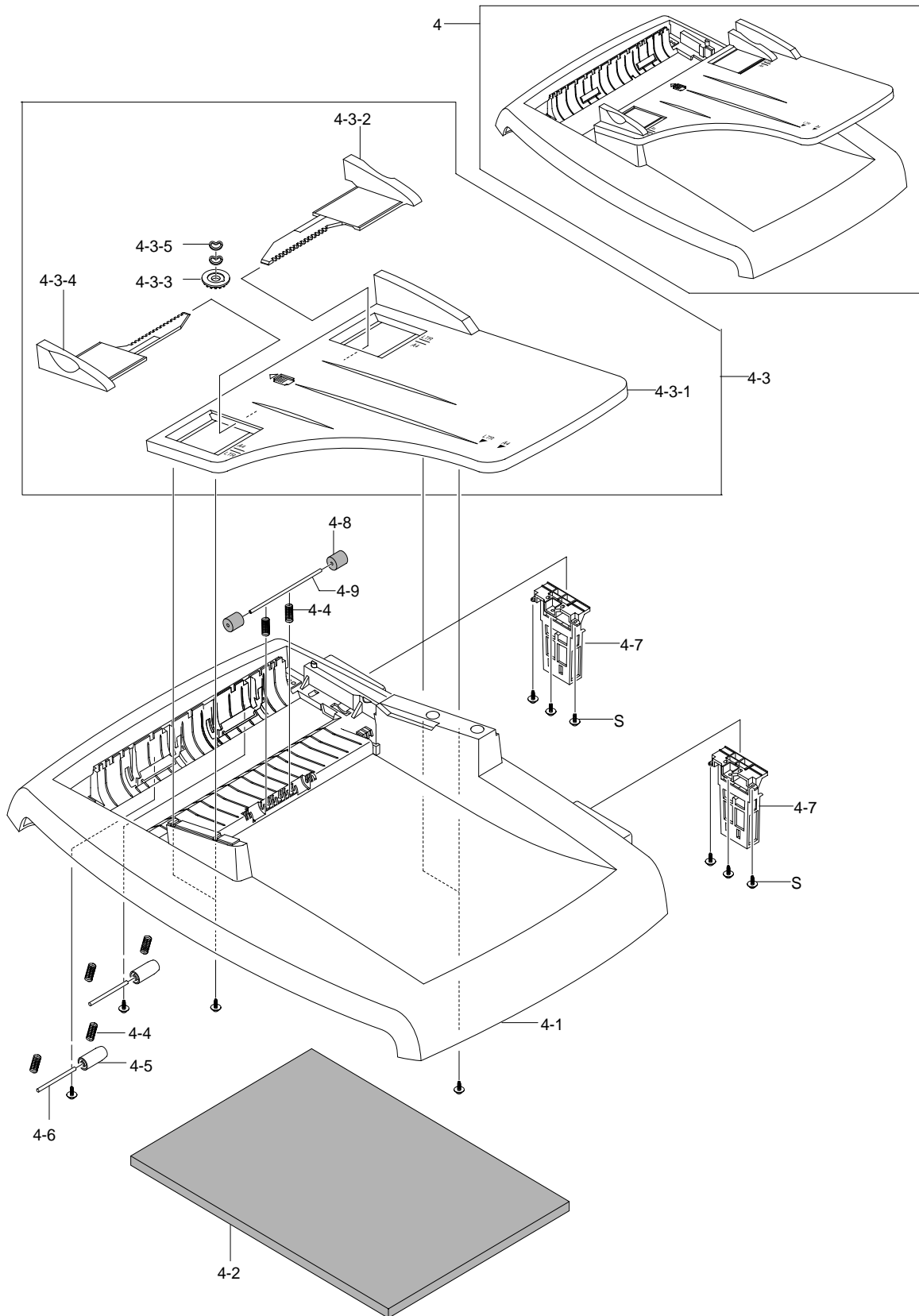

ADF Assembly Parts List

No.	Description	Part Number	Q'ty	Remark
0	ELA HOU-ADF	101 N 01337	1	
1	MEA UNIT-ADF UPPER	500 N 00106	1	
1-1	COVER-M-ADF UPPER	002 N 02195	1	
1-2	ROLLER-M-ADF IDLE	022 N 02012	1	
1-3	MEA UNIT-HOLDER ADF	500 N 00107	1	
1-3-1	RMO-ADF RUBBER	019 N 00566	1	
1-3-2	HOLDER-M-ADF	*	1	Not Spared
1-3-3	SPRING ETC-PAD	*	1	Not Spared
1-3-4	SHEET-ADF HOLDER	*	1	Not Spared
2	ELA HOU-ADF LOWER	101 N 01340	1	
2-1	COVER-M-ADF LOWER	*	1	Not Spared
2-2	PBA SUB-ADF	*	1	Not Spared
2-3	GROUND-P-ADF	*	1	Not Spared
2-4	SHAFT-M-FEED GEAR 38	*	1	Not Spared
2-5	ROLLER-DRIVE	*	1	Not Spared
2-6	PMO-ACTUATOR DOC SENSOR	*	1	Not Spared
2-7	PMO-ACTUATOR REGI SENSOR	*	1	Not Spared
2-8	PMO-ACTUATOR SCAN SENSOR	*	1	Not Spared
2-9	SPRING ETC-TORSION DOC (CC2-F)	*	3	Not Spared
2-10	IPR-GROUND_ROLLER	*	1	Not Spared
2-11	SHAFT-IDLE FEED	*	2	Not Spared
2-12	ROLLER-EXIT	*	1	Not Spared
2-13	MEC-BRUSH ANTISTATIC	*	1	Not Spared
2-14	SHEET-WHITE BAR	*	1	Not Spared
2-15	PMO-BUSH	*	4	Not Spared
2-16	CBF HARNESS-ADR	*	1	Not Spared
2-17	GEAR-AGITATOR-2	*	1	Not Spared
2-18	RING-C	*	1	Not Spared
2-19	GUIDE-STACKER SUB	*	2	Not Spared
2-S	SCREW-TAPTITE	*	9	Not Spared
3	ELA HOU-ADF MOTOR	101 N 01341	1	
3-1	BRACKET-GEAR	*	1	Not Spared
3-2	MOTOR BLOWER-ADF	*	1	Not Spared
3-3	GEAR-CLUTCH 29	*	1	Not Spared
3-4	PMO-WHITE CLUTCH SUB 29	*	1	Not Spared
3-5	GEAR-CLUTCH 39	*	1	Not Spared
3-6	RING-C	*	1	Not Spared
3-7	GEAR-IDLE 35 ADF	*	3	Not Spared
3-8	GEAR-40/21 ADF	*	3	Not Spared

ADF Assembly Parts List(cont.)

No.	Description	Part Number	Q'ty	Remark
3-9	GEAR-SWING 31/20 ADF	*	1	Not Spared
3-10	LINK-M-SWING ADF	*	1	Not Spared
3-11	GEAR-58/25 ADF	*	1	Not Spared
3-12	IMPELLER-ADF	*	1	Not Spared
3-13	GEAR-REMOVE ADF	*	1	Not Spared
3-14	WASHER-PLAIN	*	2	Not Spared
3-15	IPR-WASHER WAVE	*	1	Not Spared
3-16	WASHER-PLAIN	*	3	Not Spared
3-17	CBF HARNESS-MOTOR GND	*	1	Not Spared
3-18	RING-E	*	6	Not Spared
3-19	SCREW-TAPTITE	*	3	Not Spared
3-20	SPRING ETC PAD	*	1	Not Spared
4	MEA UNIT-COVER PLATEN	*	1	Not Spared
4-1	COVER-M-PLATEN(4IN1)	002 N 02196	1	
4-2	SHEET-WHITE SPONGE	*	1	Not Spared
4-3	MEA-TX STACKER(XEROX)	*	1	Not Spared
4-3-1	PMO-TX STACKER(XEROX)	038 N 00405	1	
4-3-2	PMO-DOC GUIDE(L)	038 N 00406	1	
4-3-3	GEAR-PINION	007 N 01210	1	
4-3-4	PMO-DOC GUIDE(R)	038 N 00410	1	
4-3-5	IPR-WASHER SPRING CU	028 N 00321	2	
4-4	SPRING ETC-FEED	*	6	Not Spared
4-5	PMO-ROLL PINCH	022 N 02014	2	
4-6	SHAFT-STACKER	006 N 01217	2	
4-7	MEA UNIT-HINGE	003 N 00888	2	
4-8	RPR-ROLLER EXIT IDLE	022 N 02019	2	
4-9	ICT-SHAFT PINCH	006 N 01218	1	
4-S	SCREW-TAPTITE	*	14	Not Spared
5	MEA UNIT-COVER OPEN	002 N 02197	1	
5-1	COVER-M-OPEN	*	1	Not Spared
5-2	PMO-GUIDE PAPER	*	2	Not Spared
6	MEA UNIT-PICKUP	130 N 01270	1	
6-1	PMO-BUSHING WHITE	*	1	Not Spared
6-2	GEAR-ADF 38	*	1	Not Spared
6-3	RING-C	*	1	Not Spared
6-4	ADF-ROLLER	022 N 02018	1	

8.4 OPE Unit Assembly

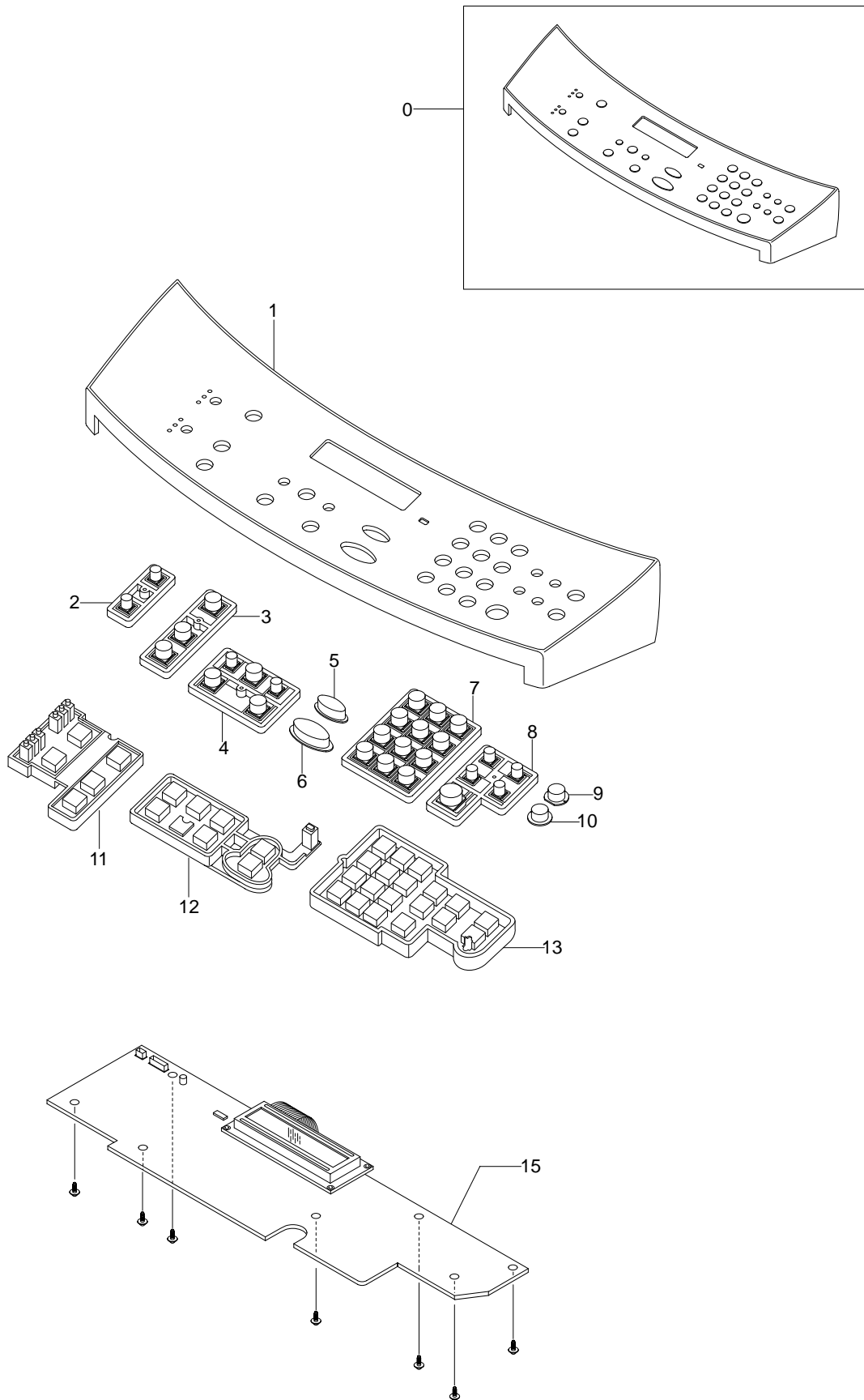

OPE Unit Assembly Parts List

No.	Description	Part Number	Q'ty	Remark
0	ELA HOU-OPE	101 N 01338	1	
1	COVER-M-OPE(4IN1)	002 N 02198	1	
2	KEY-M-RESOLUTION	003 N 00890	1	
3	KEY-M-COPY	003 N 00891	1	
4	KEY-M-SCROLL	003 N 00892	1	
5	KEY-M-STOP	003 N 00893	1	
6	KEY-M-START	003 N 00894	1	
7	KEY-M-TEL	003 N 00895	1	
8	KEY-M-FAX	003 N 00896	1	
9	KEY-M-TONER SAVE	003 N 00897	1	
10	KEY-M-TOLL SAVE	003 N 00898	1	
11	RUBBER-COPY	003 N 00899	1	
12	RUBBER-SCROLL	003 N 00900	1	
13	RUBBER-TEL/FAX	003 N 00901	1	
15	PBA SUB-OPE	140 N 62754	1	
S	SCREW-TAPTITE	*	7	Not Spared

8.5 Scanner Assembly

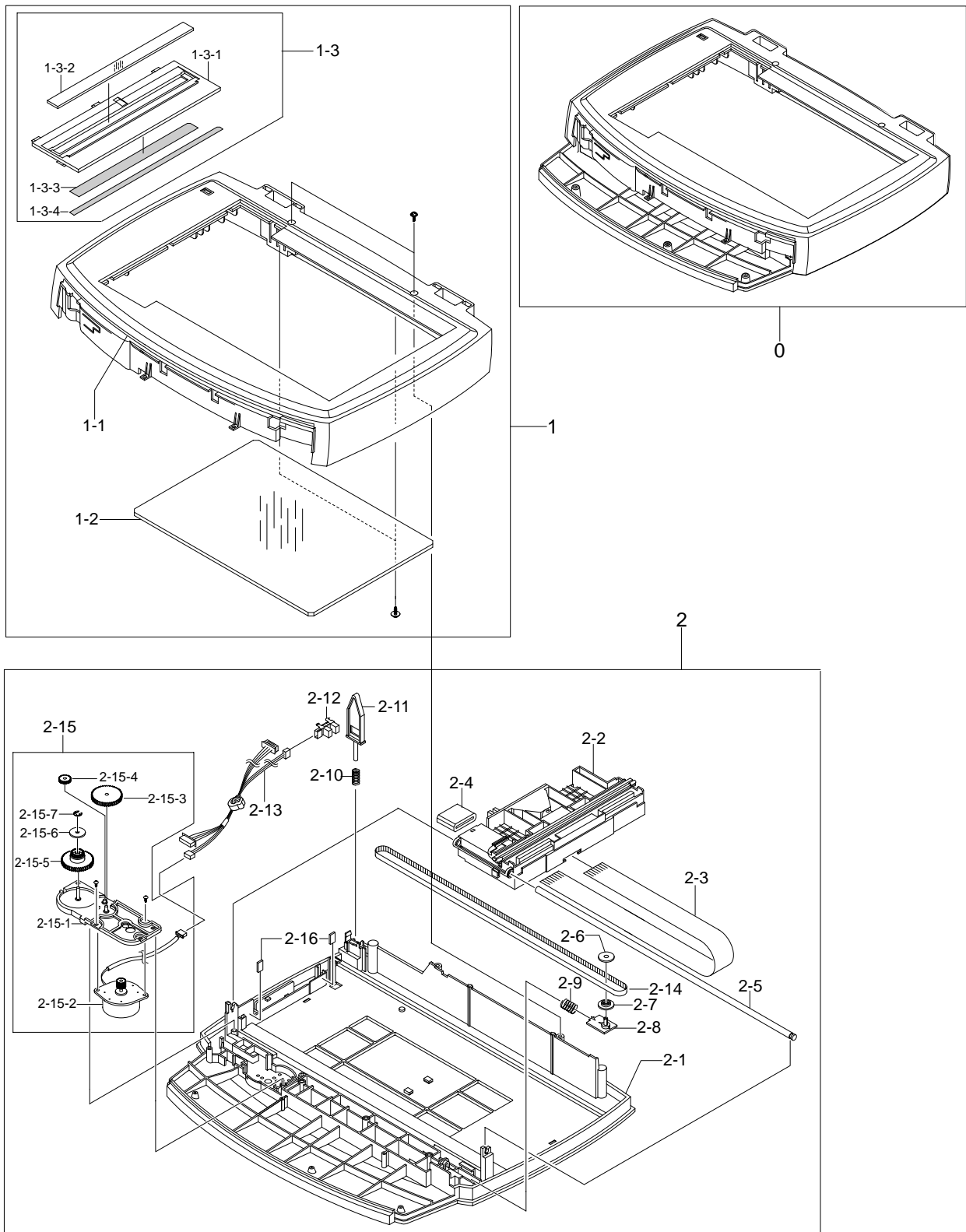

Scanner Assembly Parts List

No.	Description	Part Number	Q'ty	Remark
0	ELA HOU-PLATEN	101 N 01339	1	
1	MEA UNIT-SCAN UPPER	*	1	Not Spared
1-1	COVER-M-SCAN UPPER	002 N 02199	1	
1-2	GLASS-SCAN	118 N 00500	1	
1-3	MEA UNIT-SCAN DUMMY	500 N 00108	1	
1-3-1	COVER-M-SCAN DUMMY(4IN1)	*	1	Not Spared
1-3-2	MCT-GLASS ADF	*	1	Not Spared
1-3-3	TAPE-DOUBLE FACE	*	1	Not Spared
1-3-4	LABEL(P)-SHADING	*	1	Not Spared
2	ELA HOU-SCAN LOWER	101 N 01342	1	
2-1	COVER-M-SCAN LOWER	*	1	Not Spared
2-2	ELA HOU-CCD MODULE	101 N 01343	1	
2-3	CBF SIGNAL-CCD FFC	130 N 01271	1	
2-4	ELA UNIT-CORE	*	2	Not Spared
2-5	ICT-SHAFT CCD	130 N 01272	1	
2-6	PMO-HOLDER BELT	*	1	Not Spared
2-7	PMO-PULLEY	*	1	Not Spared
2-8	PMO-HOLDER BELT	*	1	Not Spared
2-9	SPRING ETC-BELT	*	1	Not Spared
2-10	SPRING-CS	*	1	Not Spared
2-11	PMO-LEVER SENSOR	130 N 01273	1	
2-12	PHOTO-INTERRUPTER	130 N 01274	1	
2-13	CBF HARNESS-OPE/FLAT_COVER	101 N 01344	1	
2-14	BELT-TIMING GEAR	109 N 00542	1	
2-15	ELA HOU-SCAN MOTOR	101 N 01345	1	
2-15-1	BRACKET-M-SCAN MOTOR	*	1	Not Spared
2-15-2	MOTOR STEP-SCAN	*	1	Not Spared
2-15-3	GEAR-REDUCTION	*	1	Not Spared
2-15-4	GEAR-IDLE	*	1	Not Spared
2-15-5	GEAR-TIMING	*	1	Not Spared
2-15-6	PMO-HOLDER BELT	*	1	Not Spared
2-15-7	RING-E	*	1	Not Spared
2-16	DUMPER-CCD	*	2	Not Spared

8.6 Middle Cover Assembly

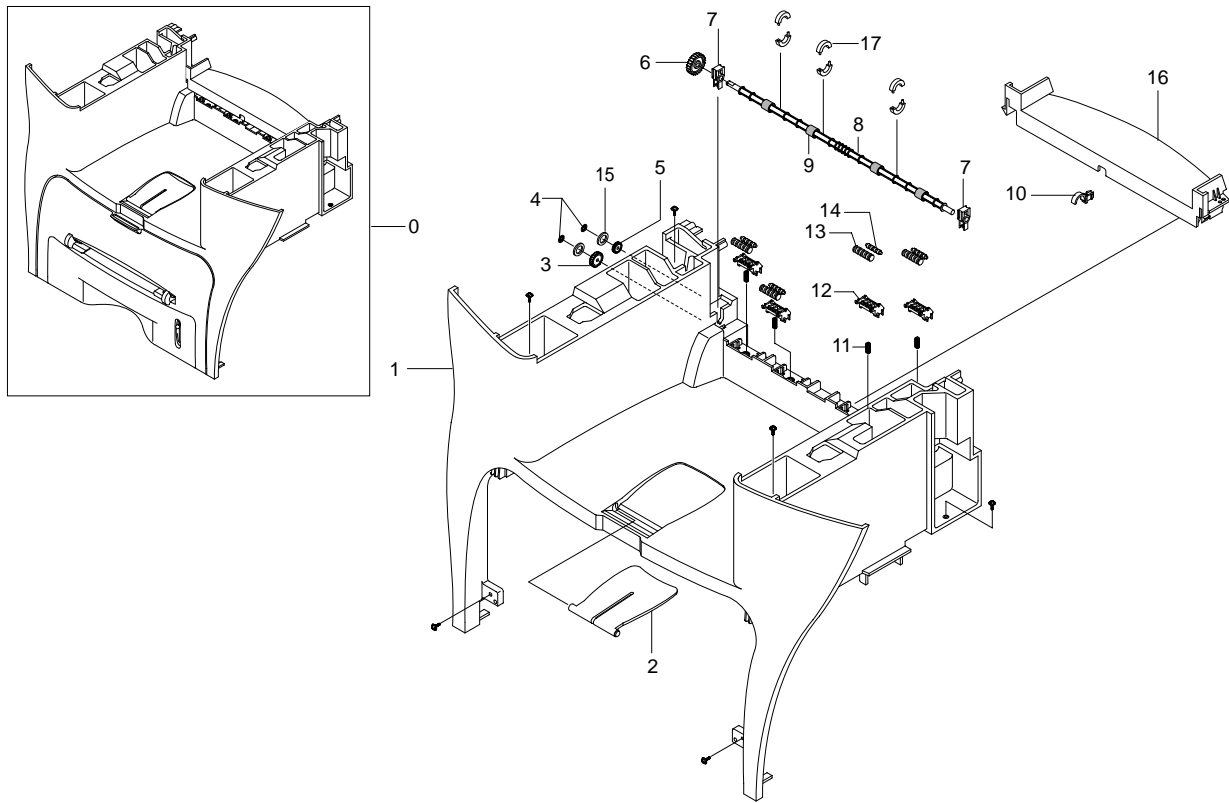

Middle Cover Assembly Parts List

No.	Description	Part Number	Q'ty	Remark
0	MEA UNIT-COVER MIDDLE	101 N 01334	1	
1	COVER-M-MIDDLE	*	1	Not Spared
2	PMO-STACKER_RX(XEROX)	*	1	Not Spared
3	RING-CS	*	2	Not Spared
4	GEAR-IDLE 23	*	1	Not Spared
5	PMO-GEAR_EXIT_DRV16	*	1	Not Spared
6	GEAR-EXIT F/DOWN	*	1	Not Spared
7	MEC-BEARING,EXIT	013 N 13802	2	
8	ROLLER-EXIT F/DOWN	*	1	Not Spared
9	RMO-RUBBER EXIT	*	4	Not Spared
10	PMO-BUSHING_F/DOWN	*	1	Not Spared
11	SPRING-CS	*	4	Not Spared
12	HOLDER-M-EXIT F/DOWN	*	4	Not Spared
13	PMO-ROLLER_EXIT,MAIN	*	4	Not Spared
14	PMO-ROLLER_EXIT,FR	*	4	Not Spared
15	WASHER-PLAIN	*	2	Not Spared
16	COVER-M-REAR UPPER	*	1	Not Spared
17	ROLLER-M_DECURL	*	6	Not Spared

8.7 Frame Assembly

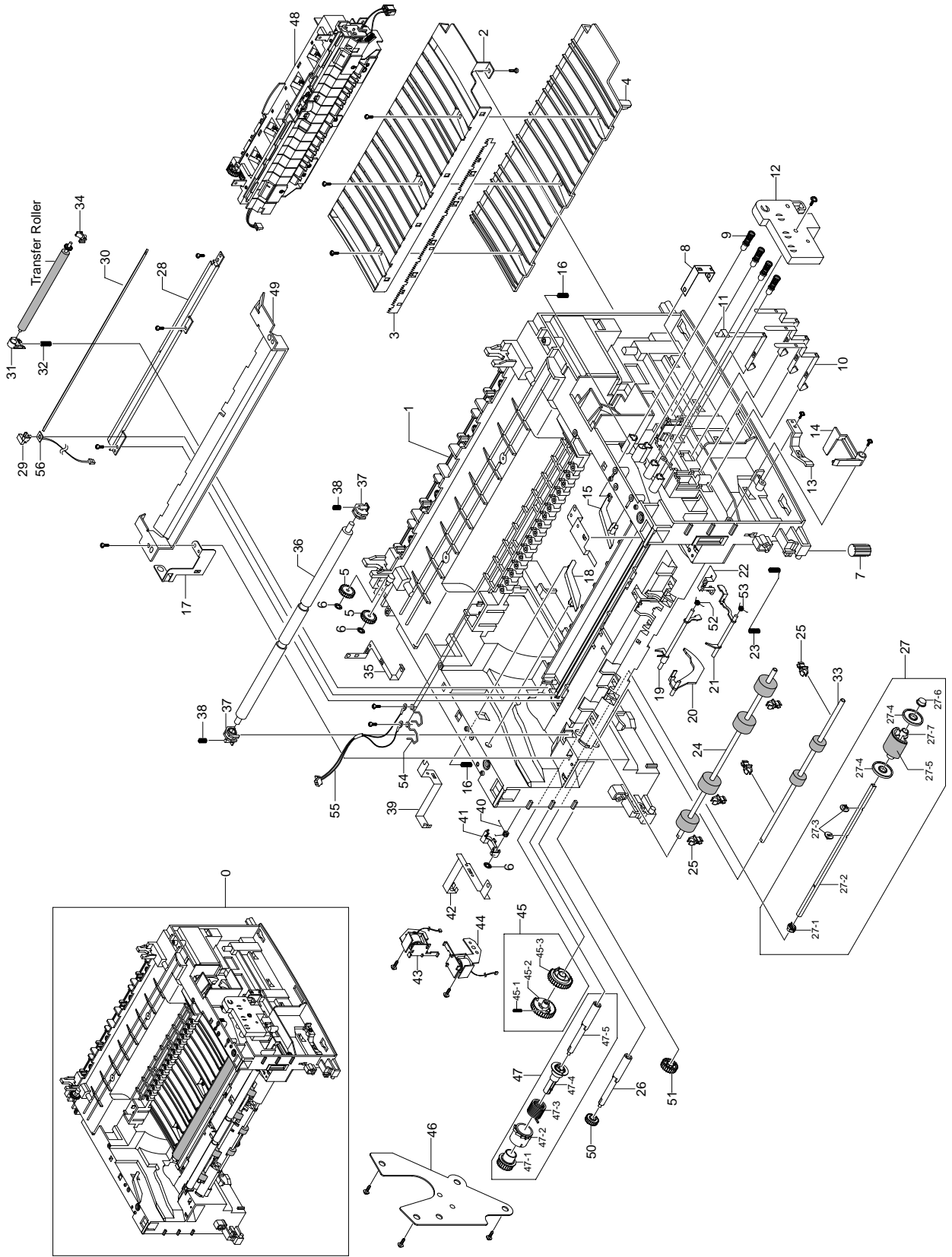

Frame Assembly Parts List

No.	Description	Part Number	Q'ty	Remark
0	ELA HOU-UNIT FRAME_110V	001 N 00407	1	110V
	ELA HOU-UNIT FRAME_220V	001 N 00408	1	220V
1	FRAME-M-BASE	*	1	Not Spared
2	GUIDE-P-TR	038 N 00407	1	
3	PLATE-P-SAW	015 N 00500	1	
4	GUIDE-M-TR RIB	038 N 00408	1	
5	PMO-GEAR_EXIT_DRV16	*	2	Not Spared
6	RING-CS	*	3	Not Spared
7	RMO-RUBBER_FOOT	*	2	Not Spared
8	IPR-P-GROUND_TR	*	1	Not Spared
9	MEC-TERMINAL	*	4	Not Spared
10	IPR-P-TERMINAL CON	*	3	Not Spared
11	IPR-P-TERMINAL CR	*	1	Not Spared
12	HOUSING-TERMINAL	101 N 01346	1	
13	PMO-LOCKER CST	120 N 00427	2	
14	PMO-ACTUATOR CVR OPEN	120 N 00423	1	
15	PMO-PLATE GUIDE DEVE_R	032 N 00390	1	
16	SPRING ETC-GUIDE DEVE	*	2	Not Spared
17	IPR-P-GROUND_GUIDE PAPER	*	1	Not Spared
18	PMO-PLATE GUIDE DEVE_L	032 N 00391	1	
19	PMO-ACTUATOR FEED	120 N 00424	1	
20	PMO-ACTUATOR EMPTY	120 N 00425	1	
21	PMO-ACTUATOR MANUAL	700 N 00093	1	
22	IPR-P-GROUND_EARTH TR	*	1	Not Spared
23	SPRING-ETC	009 N 01428	1	
24	ROLLER-FEED ROLLER 1	*	1	Not Spared
25	PMO-BUSHING FEED	*	5	Not Spared
26	SHAFT-FEED	*	1	Not Spared
27	AS-PICK UP	022 N 01608	1	
27-1	BUSH-M-PICK_UP L	*	1	Not Spared
27-2	SHAFT-P-PICK_UP	*	1	Not Spared
27-3	STOPPER-PICK_UP	*	2	Not Spared
27-4	PMO-IDLE PICK_UP	*	2	Not Spared
27-5	SPONGE-ROLLER PICK_UP	022 N 02016	1	
27-6	BUSH-M-PICK_UP R	*	1	Not Spared
27-7	HOUSING-M-PICK_UP	*	1	Not Spared
28	IPR-P-EARTH TRANSFER	117 N 01616	1	
29	HOLDER-PTL	*	1	Not Spared
30	LENS-PTL	062 N 00246	1	

Frame Assembly Parts List(Cont.)

No.	Description	Part Number	Q'ty	Remark
31	BUSH-M-TR L	016 N 00261	1	
32	SPRING ETC-TR L HAWK	*	1	Not Spared
33	ROLLER-FEED	022 N 01607	1	
34	PMO-BUSHING_TR(L)	016 N 00254	1	
35	IPR-P-GROUND_FUSER	*	1	Not Spared
36	SHAFT-FEED IDLE	*	1	Not Spared
37	BUSH-M-FEED IDLE	*	2	Not Spared
38	SPRING ETC-TR	*	2	Not Spared
39	IPR-P_GROUND_DRIVE2	007 N 01211	1	
40	SPRING-TS	*	1	Not Spared
41	CAM-M-PICK_UP	008 N 01738	1	
42	IPR-P-GROUND_DRIVE	*	1	Not Spared
43	SOLENOID-HB (PICK-UP)	121 N 00631	1	
44	SOLENOID-HB (MANUAL)	700 N 00094	1	
45	AS-GEAR PICK_UP	007 N 01212	1	
45-1	PMO-GEAR PICK_UP B	*	1	Not Spared
45-2	PMO-GEAR PICK_UP A	*	1	Not Spared
45-3	SPRING-CS	*	1	Not Spared
46	BRACKET-P-FEED	030 N 00656	1	
47	MEA UNIT-CLUTCH	022 N 01609	1	
47-1	GEAR-FEED 1	*	1	Not Spared
47-2	PMO-COLLAR_SPRING	*	1	Not Spared
47-3	SPRING-TS	*	1	Not Spared
47-4	PMO-HUB CLUTCH	*	1	Not Spared
47-5	SHAFT-FEED	*	1	Not Spared
48	ELA HOU-FUSER 110V, ROCKY	126 N 00214	1	110V
	ELA HOU-FUSER 220V, ROCKY	126 N 00215	1	220V
49	GUIDE-P-PAPER	038 N 00409	1	
50	GEAR-FEED 2	*	1	Not Spared
51	GEAR-IDLE 23	*	1	Not Spared
52	SPRING-TS	*	1	Not Spared
53	SPRING-TS	*	1	Not Spared
54	IPR-P-TERMINAL DEVE KEY	*	2	Not Spared
55	CBF HARNESS-OPC_FUSE	*	1	Not Spared
56	PBA MAIN-PTL	140 N 62757	1	
S	SCREW-TAPTITE	*	9	Not Spared
S	SCREW-TAPTITE	*	12	Not Spared
S	SCREW-ASS? TAPT	*	3	Not Spared

8.8 Fuser Assembly

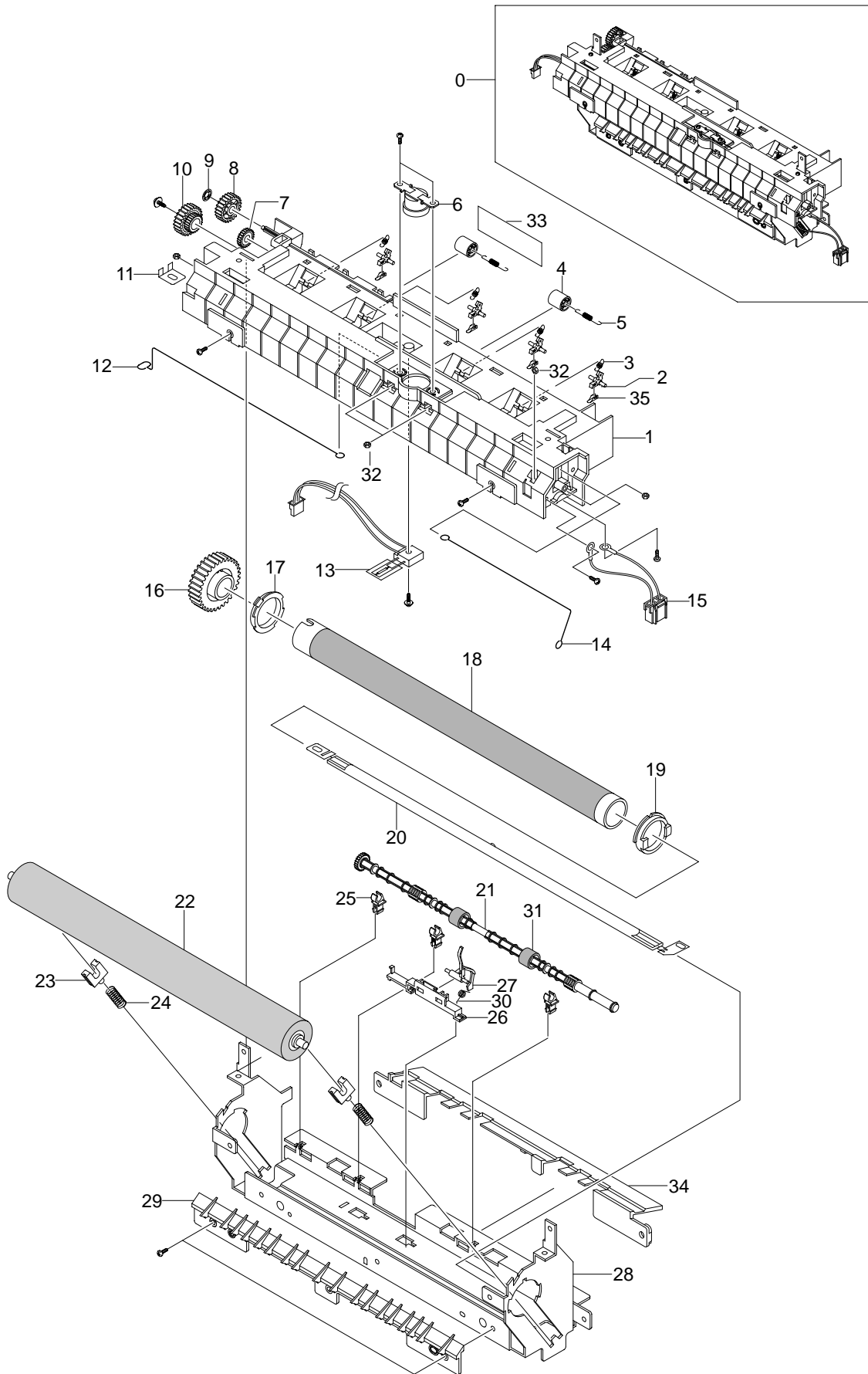

Fuser Assembly Parts List

No.	Description	Part Number	Q'ty	Remark
0	AS-FUSER 110V	126 N 00214	1	110V
	AS-FUSER 220V	126 N 00215	1	220V
1	COVER-M-FUSER	*	1	Not Spared
2	HOLDER-M-PLATE CLAW	*	4	Not Spared
3	SPRING ETC-CLAW	*	4	Not Spared
4	PMO-ROLLER EXIT	*	2	Not Spared
5	SPRING ETC-FUSER EXIT	*	2	Not Spared
6	THERMOSTAT-150	130 N 01265	1	
7	PMO-GEAR_EXIT_DRV16	*	1	Not Spared
8	GEAR-IDLE 23	*	1	Not Spared
9	RING-CS	*	1	Not Spared
10	GEAR-RDCN 25/15	007 N 01213	1	
11	IPR-ELECTRODE_LAMP	*	1	Not Spared
12	ELECTRODE-WIRE_L	*	1	Not Spared
13	THERMISTOR-NTC	130 N 01266	1	
14	ELECTRODE-WIRE_R	*	1	Not Spared
15	CBF HARNESS-FUSER 110V	152 N 11464	1	110V (WHITE)
	CBF HARNESS-FUSER 220V	152 N 02013	1	220V (BLACK)
16	GEAR-FUSER, Z37	007 N 01205	1	
17	BUSH-M-HR L	*	1	Not Spared
18	ROLLER-HEAT	022 N 01610	1	
19	BUSH-M-HR R	016 N 00262	1	
20	LAMP-HALOGEN	122 N 00231	1	110V
	LAMP-HALOGEN	122 N 00229	1	220V
21	ROLLER-M-EXIT F/UP	*	1	Not Spared
22	ROLLER-PRESSURE	022 N 01611	1	
23	BEARING-PRESSURE/R	*	2	Not Spared
24	SPRING-CS	*	2	Not Spared
25	PMO-BUSHING TX	*	3	Not Spared
26	HOLDER-ACTUATOR	*	1	Not Spared
27	PMO-ACTUATOR_EXIT	120 N 00428	1	
28	IPR-P-FRAME_FUSER	*	1	Not Spared
29	GUIDE-M-INPUT	*	1	Not Spared
30	SPRING-TS	*	1	Not Spared
31	RMO-RUBBER_EXIT	*	2	Not Spared
32	NUT-HEXAGON	*	5	Not Spared
33	LABEL(P)-CAUTION, HOT_FUSER	*	1	Not Spared
34	COVER-M-EXIT LOWER	*	1	Not Spared
35	PLATE-P-CLAW	*	4	Not Spared

8.9 Cassette Assembly

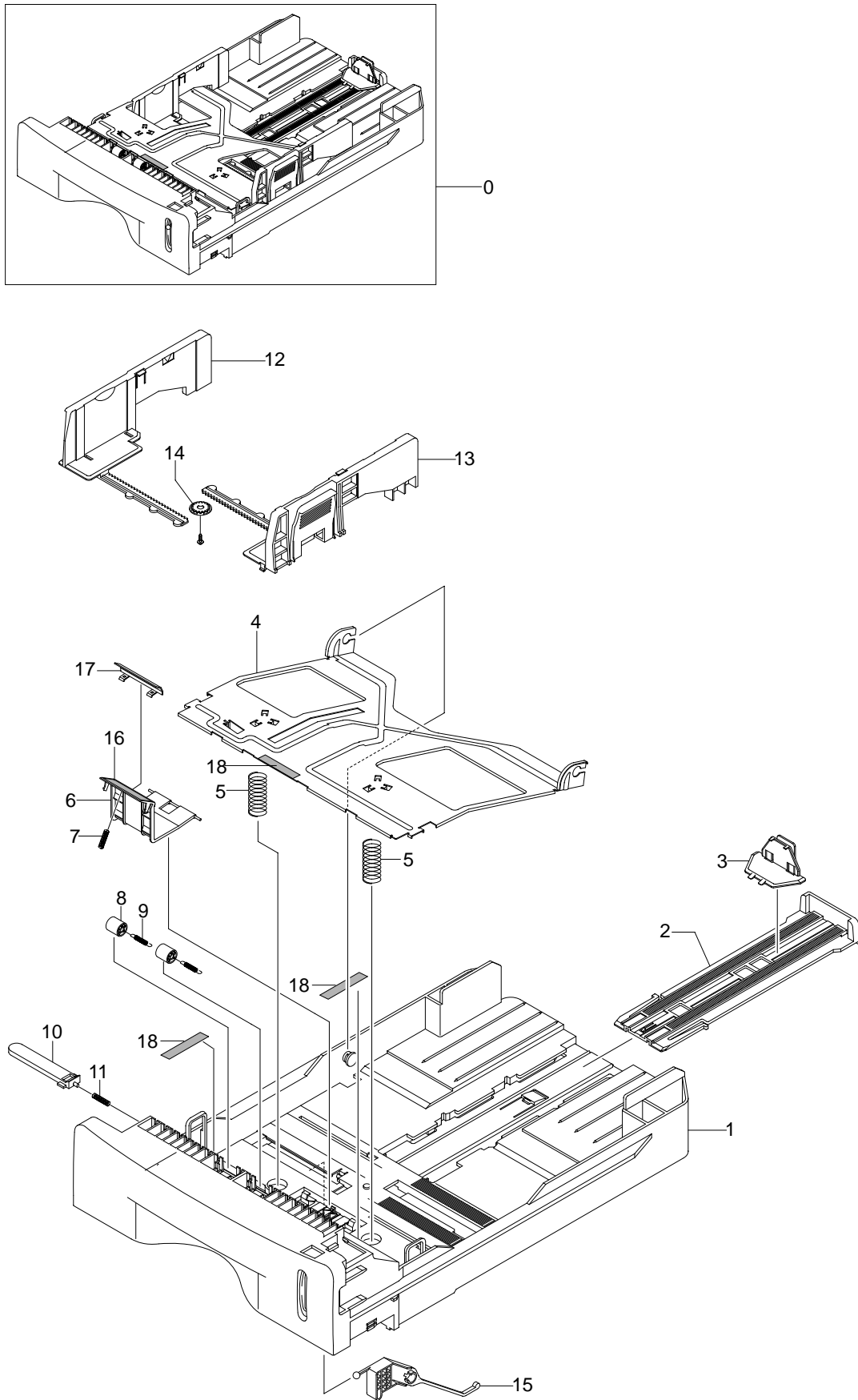

Cassette Assembly Parts List

No.	Description	Part Number	Q'ty	Remark
0	MEA UNIT-CASSETTE, USA	050 N 00427	1	
1	FRAME-M_CASSETTE	*	1	Not Spared
2	PMO-EXTENSION LARGE	*	1	Not Spared
3	PMO-EXTENSION SMALL	*	1	Not Spared
4	PLATE-P-KNOCK_UP	*	1	Not Spared
5	SPRING-CS	*	2	Not Spared
6	HOLDER-M-PAD	*	1	Not Spared
7	SPRING ETC-EXIT ROLL FD	*	1	Not Spared
8	ROLLER-M-IDLE FEED	*	2	Not Spared
9	SPRING-ES	*	2	Not Spared
10	PMO-PLATE_LOCKER	*	1	Not Spared
11	SPRING ETC-LOCKER,PLATE	*	1	Not Spared
12	ADJUST-M-CASSETTE_L	*	1	Not Spared
13	ADJUST-M-CASSETTE_R	*	1	Not Spared
14	GEAR-PINION	*	1	Not Spared
15	INDICATOR-M-LEVER INDICATOR	018 N 00182	1	
16	RPR-FRICTION PAD	019 N 00742	1	
17	IPR-PLATE PAD	*	1	Not Spared
18	RPR-PAD CASSETTE	*	3	Not Spared

Memo

9. Block Diagram

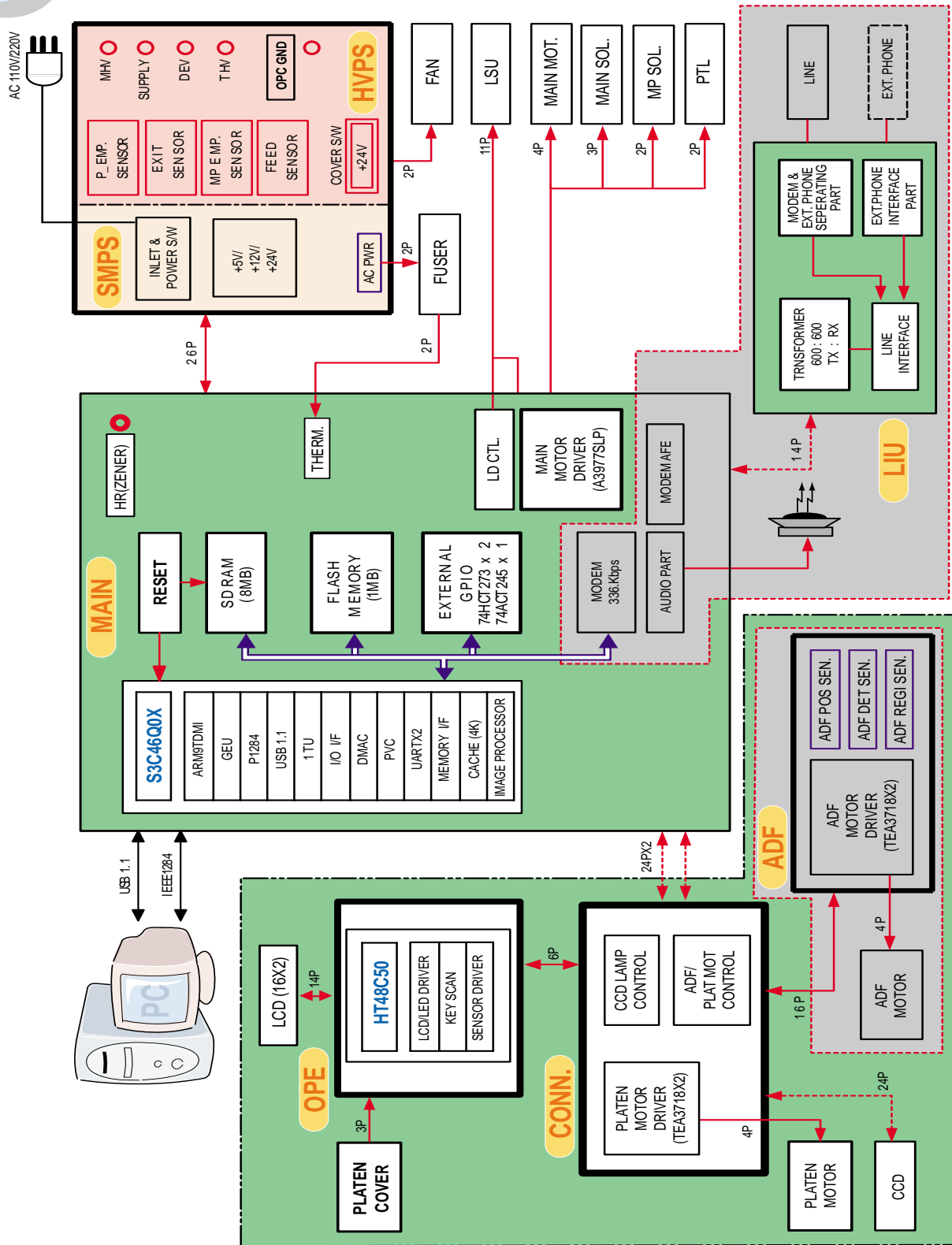

Memo

10. Connection Diagram

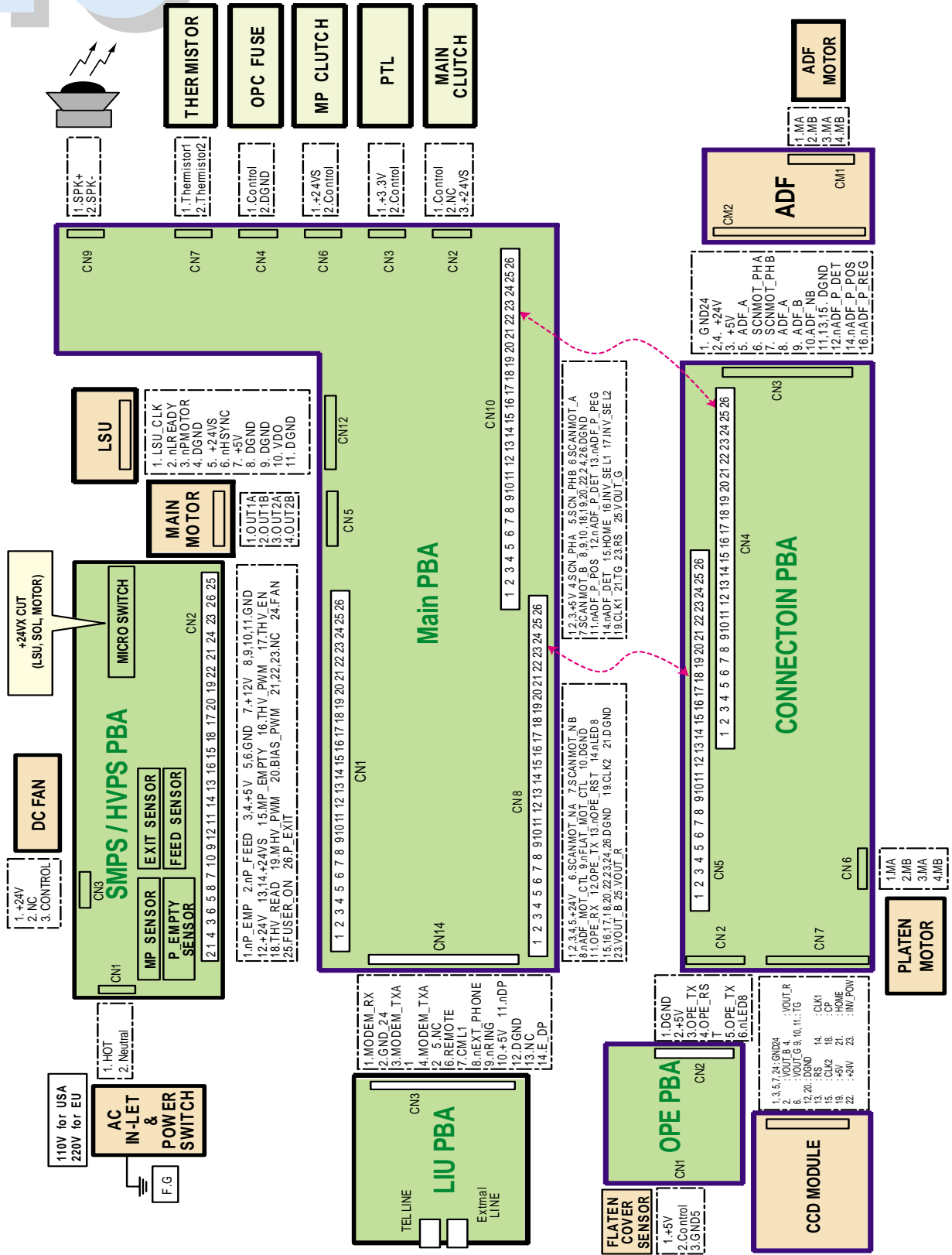

Memo

Free Manuals Download Website

<http://myh66.com>

<http://usermanuals.us>

<http://www.somanuals.com>

<http://www.4manuals.cc>

<http://www.manual-lib.com>

<http://www.404manual.com>

<http://www.luxmanual.com>

<http://aubethermostatmanual.com>

Golf course search by state

<http://golfingnear.com>

Email search by domain

<http://emailbydomain.com>

Auto manuals search

<http://auto.somanuals.com>

TV manuals search

<http://tv.somanuals.com>