

DocuTech 128/155/180 HighLight Color

Operator Guide



Prepared by:
Xerox Corporation
Global Knowledge and Language Services
800 Phillips Road Bldg. 845-17S
Webster, New York 14580
USA

©2006 by Xerox Corporation. All rights reserved.

Copyright protection claimed includes all forms and matters of copyrightable material and information

now allowed by statutory judicial law or hereinafter granted, including without limitation, material generated

from the software programs displayed on the screen such as icons, screen displays, or looks.

Printed in the United States of America.

XEROX® and all Xerox product names mentioned in this publication are trademarks of XEROX CORPORATION.

Other company trademarks are also acknowledged.

Changes are periodically made to this document. Changes, technical inaccuracies, and typographic errors will be corrected in subsequent editions.

Product Recycling and Disposal

If you are managing the disposal of your Xerox product, please note that the product contains lead, mercury and other materials whose disposal may be regulated due to environmental considerations in certain countries or states. The presence of lead and mercury is fully consistent with global regulations applicable at the time that the product was placed on the market.

European Union

Some equipment may be used in both a domestic/household and a professional/business application.

Domestic/Household Environment



Application of this symbol on your equipment is confirmation that you should not dispose of the equipment in the normal household waste stream.

In accordance with European legislation end of life electrical and electronic equipment subject to disposal must be segregated from household waste.

Private households within EU Member States may return used electrical and electronic equipment to designated collection facilities free of charge. Please contact your local disposal authority for information.

In some Member States when you purchase new equipment your local retailer may be required to take back your old equipment free of charge. Please ask your retailer for information.

Professional/Business Environment



Application of this symbol on your equipment is confirmation that you must dispose of this equipment in compliance with agreed national Procedures.

In accordance with European legislation end of life electrical and electronic equipment subject to disposal must be managed within agreed procedures.

Prior to disposal please contact your local dealer or Xerox representative for end of life take back information.

Table of Contents

1 Safety notices

System safety	1-1
Laser safety	1-1
Ozone safety	1-2
Operation safety	1-2
European Union declaration of conformity	1-3
Certification to 1999/5/EC Radio Equipment and Telecommunications Terminal Equipment Directive 1-4	
Electricity at Work Regulation - UK	1-5
Check your understanding	1-6
Additional queries	1-7

2 System components

Electronic reprographics process	2-1
DocuSP controller	2-1
DocuTech Printer	2-1
Optional Components	2-2
Functional overview	2-2
Paper weights	2-4
Special stocks	2-4
General paper characteristics	2-5
Graphical user interface overview	2-5
System software and job flow	2-6
Printer overview	2-7
High volume printer	2-8
Production publisher	2-14
The System	2-23
System Hardware	2-23
Paper sizing and print speed	2-26

3 Routine maintenance

Cleaning and maintenance overview	3-1
Necessary Precautions	3-1
Finisher precaution	3-2
Paper	3-3
Storing paper	3-3
Conditioning paper	3-4
Paper curl	3-5
Adding paper to tray 1 or 2	3-6
Using the custom transfer assist blade	3-7
Adjusting for paper curl	3-9
Adjusting the decurler lever	3-11
Maintaining the printer	3-12
Replacing the black dry ink bottle	3-12
Replacing the highlight color container	3-14
Changing the highlight color Customer Changeable Units	3-16
Adding fuser shield	3-23

Waste containers	3-27
Wire Module Removal and Replacement	3-30
Cleaning the system and its components	3-32
Cleaning the 18/36-track cartridge tape drive	3-32
Cleaning the 26-track cartridge tape drive	3-33
Cleaning the DVD drive	3-33
Cleaning the diskette drive	3-33
Cleaning the sensors and the reflecting surfaces	3-34
Cleaning the Q850 and Q861 sensor	3-34
Cleaning the Q1011/1009 sensor and mirror	3-36
Cleaning the Q1106 and Q1166 sensors	3-36
Cleaning the Q1107 sensor	3-37
Cleaning the Q1164 sensor	3-38
Cleaning the display	3-39
Cleaning the exterior surfaces of the system	3-39
Clearing or cleaning the finisher sensors	3-40
Clearing the Q1201 sensor	3-40
Clearing the Q1202 and Q1203 sensors	3-41
Clearing the Q1222 and Q1210 sensors	3-43
Clearing the Q1205, Q1206, and Q1207 sensors	3-44
Clearing the Q1213 sensor	3-45
Clearing the Q1221, Q1218, and Q1227 sensors	3-46
Cleaning the binder	3-47
Cleaning the binder tape guides	3-49
Cleaning the binder platen	3-49
Cleaning the flappers	3-50
Cleaning the calipers	3-51
Closing the binder	3-52
Replacing the stitcher spool A	3-52
Storing the binder tape reels	3-59
Replacing the binder tape reel	3-61
Adjusting the binder tape registration	3-65

4 Problem Solving

How problems are displayed	4-1
Printer faults and fault windows	4-1
When a fault occurs	4-2
Resolving a processor problem	4-2
Solving print quality problems	4-6
Clearing paper jams	4-6
Incorrect paper size message	4-22
Interposer problems	4-23
Finisher problems	4-23
Binder tape fault	4-25
Stitcher spool A fault	4-26
Checking paper curl	4-30
Customer Support Center	4-30

5 Technical information

DocuTech printer specifications	5-1
Printer rates	5-1
Paper tray capacities	5-1
Additional paper capacities	5-3
Printer satisfaction guides	5-4

Stock satisfaction guides	5-5
Using non-standard stock	5-10
Paper stock rotation	5-11
Finisher satisfaction guides	5-14

6 Service and supplies

Xerox support services	6-1
Customer support	6-1
Operator training	6-2
Supplies service	6-2
Routine maintenance	6-4
Meter reading and reporting	6-4
Consumable supplies table	6-4

Introduction

The DocuTech 128/155/180 HLC Operator Guide is one of a number of publications that make up the Xerox Document Services Platform Series.

About this guide

The guide is intended for Xerox DocuTech 128/155/180 HLC operators whose job consists of the routine operation of this printing system: operating each of the system components, running print jobs, solving simple system problems, and performing basic maintenance tasks, such as replenishing printer supplies.

If you are a lead operator, or your job involves some programming or systems administration tasks, as well as operating the DocuTech 128/155/180 HLC system, use the on-line help system and the other documents in the Xerox Document Services Platform Series to supplement the information in this guide.

Before using this guide, become familiar with its contents and conventions.



WARNING: *Both power cords with the printer must be disconnected from the printer in order to completely power down the machine.*

Contents

This section lists the contents of this guide.

- “System components” contains an explanation of each of the system components.
- “Routine maintenance” describes the routine activities you perform to maintain the reliability and productivity of your printer.
- “Problem solving” describes how the system informs you of problems. When you know there is a system problem, you can take measures suggested by the system to correct the problem. You can also use the problem and solution tables in this section to resolve recurring problems.

- “Technical information” contains the hardware and software capacity guidelines for the DocuTech 128/155/180 HLC systems.
- “Supplies” lists the supplies that you might want to keep in stock, and the information you need to order them.

Conventions

This guide uses the following conventions:

- All caps and angle brackets—Within procedures, the names of keys are shown in all caps within angle brackets (for example, press <RETURN>).
- Angle brackets—Variable information, or the position of a specified argument in the command syntax, appears in angle brackets (for example, List Fonts <Pattern>).
- **Bold**—Within procedures, text and numbers that you enter are shown in bold (for example, enter **boot**).
- Enter—Within procedures, the two-step process of keying in data and pressing <RETURN> (for example, enter y).
- *Italics*—Document and library names are shown in italics (for example, the *Xerox Document Services Platform Series System Guide*).
- Square brackets—Names of options you select are shown in square brackets (for example, Select [Exit]).
- Quotes—Keywords you can enter as arguments appear in quotes (for example, “US Letter”).
- Vertical bars—Alternatives to specified arguments are separated by vertical bars (for example, -pdl <ps | hppcl | ascii | tiff>).



NOTE: *Notes contain important supplemental information pertaining to the task that you should read.*



CAUTION: *Cautions alert you to an action that could damage hardware, software, or your data.*



WARNING: *Warnings alert you to conditions that may affect the safety of people.*

1 Safety notices

System safety

It is your responsibility to ensure your Xerox equipment is safe at all times. This section includes equipment safety notices related to laser safety, ozone safety, and operation safety.

Laser safety



WARNING: *Use of controls or adjustments, or performances other than specified herein, may result in hazardous radiation exposure.*

The Xerox DocuTech 128/155/180 HLC models are certified to comply with laser performance standards set by the U.S. Department of Health, Education, and Welfare as Class 1 laser products. This is a class of laser products that does not emit hazardous radiation. This is possible only because the laser beam is totally enclosed during all modes of customer operation.

When performing operator functions, laser warning labels may be visible. These labels are to alert and remind the service representative and are placed on or near panels or shields which require a tool for removal.

THE PANELS TO WHICH THESE LABELS ARE FIXED OR NEAR ARE NOT TO BE REMOVED BY ANYONE OTHER THAN AUTHORIZED TRAINED PERSONNEL.



Figure 1-1. Laser warning label

Ozone safety

This product produces ozone during normal operation. The ozone produced is dependent on copy volume and is heavier than air. Providing the proper environmental parameters as specified in the Xerox installation instructions ensures that concentration levels meet safe limits.

Operation safety

Your Xerox equipment and supplies have been designed and tested to meet strict safety requirements. These include safety agency examination and approval, and compliance to established environmental standards.

Attention to the following notes ensures the continued safe operation of your equipment.

- The system is heavy. Ensure that the floor is level and strong enough to support the weight of the system.
- Do not place the system near a heat source.
- To move the system, call a Service Representative.
- Do not use an extension cord. Always connect the system power cable to a properly grounded power source receptacle. If in doubt, have the receptacle checked by a qualified electrician.
- Do not use an adaptor plug to connect the system to an electrical outlet that lacks a ground connection terminal.



WARNING: *Improper connection of the equipment grounding conductor can result in risk of electrical shock.*

- Do not locate the system where people may walk on the system power cable. Do not place objects on the system power cable.
- Never override or disable electrical or mechanical interlocks.



WARNING: *Do not push objects into slots and openings on the system. Making contact with a voltage point or shorting out a part could result in fire or electrical shock.*

- If you hear unusual noises or smell strange odors, switch off the system power immediately. Disconnect the system power cables from the electrical outlet and call a service representative.
- Do not place containers of coffee or other liquids on the system.
- Switch off the system power, disconnect the power cables, and call a service representative when any of the following conditions occur:

- The power cable is damaged or frayed.
- Liquid is spilled into the system.
- The system is exposed to water.
- Any part of the system is damaged.
- Always use materials and supplies specifically designed for your Xerox equipment. Use of unsuitable materials may result in poor performance and can possibly create a hazardous situation.
- Never attempt any maintenance function that is not specifically described in this *Operator Guide*.
- Never remove any covers or guards that are fastened with screws. There are no operator-serviceable areas within these covers.
- Never use supplies or cleaning materials for other than their intended purposes. Keep all materials out of the reach of children.

European Union declaration of conformity

Approvals and certification

The CE marking applied to this product symbolizes Xerox Europe Declaration of Conformity with the following applicable Directives of the European Union as of the dates indicated below.

- **January 1, 1995:** Council Directive 73/23/EEC amended by Council Directive 93/68/EC, approximation of the laws of the member states related to low voltage equipment.
- **January 1, 1996:** Council Directive 89/336/EC, approximation of the laws of the member States related to electromagnetic compatibility.
- **March 9, 1999:** Council Directive 1995/5/EC on radio equipment and telecommunications terminal equipment and the mutual recognition of their conformity.

A full declaration, defining the relevant directives and referenced standards can be obtained from your Xerox Europe representative.



WARNING: *Changes or modification to this equipment not specifically approved by Xerox Europe may void user's authority to operate the equipment. Shielded cables must be used with this equipment to maintain compliance with the EMC Directive (89/336/EEC).*



WARNING: *This is a Class A product. In a domestic environment this product may cause radio interference in which case the user may be required to take adequate measures.*



WARNING: *This system is certified manufactured and tested in compliance with strict safety and radio frequency interference regulations. Any unauthorized alteration which includes the addition of new functions or the connections of external devices may impact this certification. Please contact your local Xerox Europe representative for a list of approved accessories. Shielded cables must be used with this equipment to maintain compliance with the EMC Directive (89/336/EEC). This equipment is not primarily intended for use in a domestic environment.*



WARNING: *In order to allow this equipment to operate in proximity to industrial, scientific, and medical (ISM) equipment, the external radiation from the ISM equipment may have to be limited or special mitigation measures taken.*

Certification to 1999/5/EC Radio Equipment and Telecommunications Terminal Equipment Directive

This Xerox product has been self-certified by Xerox for pan-European single terminal connection to the analogue public switched telephone network (PSTN) in accordance with Directive 1999/5/EC.

The product has been designed to work with the national PSTNs and compatibles PBXs of the following countries:

- Austria
- Belgium
- Denmark
- France
- Finland
- Germany
- Greece
- Iceland
- Ireland
- Italy
- Luxembourg
- Netherlands
- Norway
- Portugal
- Spain
- Sweden
- Switzerland
- United Kingdom

In the event of problems, you should contact your local Xerox representative in the first instance.

The product has been tested to and is compliant with TBR21, a specification for terminal equipment for use on analogue switched telephone networks in the European Economic Area.

The product may be configured to be compatible with other country networks. Please contact your Xerox representative if it needs to be reconnected to another country's network.

There are no user-adjustable settings in the product.



NOTE: *Although this product can use either loop disconnect (pulse) or DTMF (tone) signalling, it is recommended that it is set to use DTMF signalling. DTMF signalling provides reliable and faster call set-up.*

Modification, connection to external control software or to external control apparatus not authorized by Xerox, will invalidate its certification.

Electricity at Work Regulation - UK

The Electricity at Work Regulation applies only to England and Wales.

The Regulation

The Electricity at Work Regulation 1989 came into force in England and Wales on 1 April 1990. This 1989 Regulation places a duty on all employers and self employed persons to ensure the electrical systems in their premises are constructed, maintained and operated in such a manner as to prevent, so far as reasonably practical, danger. This includes ensuring all electrical equipment connected to such electrical systems are safely constructed, maintained and operated.

All Xerox equipment have been designed to exacting safety standards. They have all undergone a variety of stringent safety tests including earth bond, insulation resistance and electrical strength tests. Xerox Europe manufacturing plants have been awarded ISO 9000 quality certification and are subject to regular audits by the British Standards Institution or equivalent national standards body.

Xerox equipment which has been properly and regularly serviced and maintained should not have to undergo additional specific safety tests pursuant to the 1989 Regulation. Customers wishing to complete safety testing should contact Xerox Europe Technical Centre for advice prior to any test implementation.

Xerox equipment should, however, be properly and regularly serviced and maintained at all times.

Check your understanding

Please review the questions and answers that follow to ensure that you understand the Electricity at Work Regulation in England and Wales.

Question **What is the Electricity at Work Regulation?**

Answer The Electricity at Work Regulation 1989 came into force in England and Wales on 1 April 1990. This 1989 Regulation places a duty on **all employers and self-employed persons** to ensure the electrical systems in their premises are constructed, maintained and operated in such a manner as to prevent, so far as reasonably practicable, danger. This includes ensuring all electrical products connected to such electrical systems are safely constructed, maintained and operated.

Question **Does Xerox Europe comply with the Electricity at Work Regulation?**

Answer The regulation places a duty on **all employers and self employed persons** to ensure the electrical systems in their premises are, effectively safe.

This regulation does not impose on, amongst others, **manufacturers or suppliers** of such electrical systems.

However, rest assured that all Xerox equipment which Xerox Europe and its authorized distributors supply to customers conforms with all the relevant safety legislation and standards.

Question **Is Xerox equipment safe?**

Answer All Xerox equipment supplied by Xerox Europe and their authorized distributors conforms to all relevant safety legislation and standards.

Question **Is the Xerox equipment in my premises safe?**

Answer All Xerox equipment supplied by Xerox Europe and their authorized distributors conforms to all relevant safety legislation and standards. However, like all electrical equipment, they have to be regularly serviced and maintained by competent persons.

Xerox Europe Customer Service Engineers ensure Xerox equipment is serviced and maintained to exacting Xerox safety standards. If you would like your Xerox equipment to be serviced and maintained to such high standards, please contact your local Xerox Europe Customer Service Organization. They will be pleased to assist you.

Question **Does the Xerox equipment in my premises comply with the Electricity at Work Regulations?**

Answer All employers and self-employed persons must ensure that the electrical systems in their premises are safe. This will include ensuring Xerox equipment in such premises is safe.

Xerox Europe's Product Safety function has prepared a guide which contains a list of tests which may be completed by your Xerox Europe Customer Service Organization. **THESE TESTS**

MUST BE CARRIED OUT ONLY BY PERSONS WHO POSSESS THE RELEVANT SKILL, KNOWLEDGE AND EXPERIENCE TO CARRY OUT SUCH TESTS.

Please contact the Xerox Europe Customer Service Organization for further information.

THE USE OF INAPPROPRIATE TEST PROCEDURES AND TEST EQUIPMENT MAY PROVIDE MISLEADING RESULTS AND MAY CAUSE DEATH, PERSONAL INJURY AND/OR DAMAGE TO PROPERTY.

Question I would like to carry out my own safety tests on the Xerox equipment in my premises.

Answer You may, of course, request such tests as you deem necessary to satisfy yourself that your Xerox equipment is safe. Your Xerox Europe Customer Support will be pleased to advise you on such testing.

Question I require records of all tests.

Answer After safety testing, your Xerox Europe Customer Service Engineer will provide you with a certificate which details the results of all tests completed.

In the event of any defect being noted, the Xerox equipment will be switched off and disconnected from the supply until the defect has been corrected. You will be advised of such action to enable such defects to be corrected.

Additional queries

Please contact the Xerox Europe Technical Centre or your authorized Xerox representative if you have any queries regarding the information provided in this document.

2 System components

The Xerox DocuTech HLC printers are electronic reprographics systems. They are high volume printers available in multiple configurations. These versatile, high performance printing systems enable personal computers and other network-connected devices (such as workstations and graphic scanners) to produce documents incorporating graphics, forms, logos, signatures, and fonts.

Electronic reprographics process

The Xerox DocuTech HLC system consists of a DocuSP controller and a DocuTech printer.

DocuSP controller

The DocuSP controller accepts electronic print input created by client software in ASCII, TIFF, HP PCL, PostScript, PPML, LCDS, IPDS, VIPP or PDF format. This print input is passed on to the system through a network connection. The DocuSP software performs the necessary data conversion, creating an electronic file which is stored temporarily in a print queue on the DocuSP controller. This electronic image is then passed directly on to the printer for production.

DocuTech Printer

The DocuTech 180 prints up to 180 prints per minute using 8.5 x 11 inch/A4 (216 x 279 mm) stock.

The DocuTech 155 prints up to 155 prints per minute using 8.5 x 11 inch/A4 (216 x 279 mm) stock.

The DocuTech 128 prints up to 128 prints per minute using 8.5 x 11 inch/A4 (216 x 279 mm) stock.



NOTE: *The DocuTech HLC prints in black and white plus one highlight color.*



NOTE: *Prints per minute vary, depending on paper size, for all printers.*

Optional Components

- Inverter Feeder/Stacker and up to 3 Feeder/Stackers
- 2-Tray Interposer and Finisher (Production publisher configuration)



NOTE: *The initial release of the Production publisher (Interposer and Finisher) configuration is 180 PPM only and does not support LCDS & IPDS.*

Functional overview

The Xerox DocuTech HLC prints high quality, high resolution documents in simplex or duplex mode at high production speeds, from LCDS, PostScript, PCL, and other data streams. The system can switch between printing different types of data streams without a need for rebooting or reconfiguring software.

The printer supports:

- Duplex printing
- Media handling of multiple weights, sizes, and types
- Optional modules for enhanced finishing and output to third-party finishing devices
- Optional enabling of a third-party roll feeder
- Depending on your configuration: optional high-capacity feeder/stacker modules, which provide additional feeder trays and output bins
- Depending on your configuration: Interposer/Finisher/Binder
- High resolution of LCDS*, PostScript, and PCL data streams (shown in the following table)



NOTE: **The initial release of the Production publisher (Interposer and Finisher) configuration is 180 PPM only and does not support LCDS & IPDS.*

Table 1. Data stream resolution

Data stream	Input resolution	Print resolution: DP128/155/180 HLC
LCDS	300 by 300 dpi	600 x 2400 dpi (High volume printer only)
PostScript and PCL	300 by 300 dpi or 600 by 600 dpi	600 x 2400 dpi (High volume printer) 600 x 600 dpi (Production publisher)

Data formats supported

The Xerox DocuTech 128/155/180 HLC can print the following data formats:

- ASCII
- LCDS*
- IPDS*
- PCL
- PDF
- PostScript
- TIFF
- PPML



NOTE: * *Not supported on the Production publisher configuration at this time.*

The system prints LCDS data from a mainframe host computer, emulating an IBM 4245 or 3211 page printer. The printing system can receive data over a channel through bus and tag cables, and through the Socket Gateway or lpr using TCP/IP protocol.

The system also prints PostScript and PCL data submitted over a network (Ethernet or AppleTalk) from a variety of clients:

- PCs (Windows and Windows NT)
- Sun workstations (UNIX)
- UNIX command line clients: lpr (including lp) and Xerox Command Line Client (CLC)
- NetWare Q-Server through a Novell print server (bindery mode only)
- Apple Macintosh workstations

Stock specifications

The success of any print run depends on proper selection, care, and handling of the paper or other stock that is used. It is very important to select, store, condition, and load print media properly in order to keep your printer running at optimum efficiency.

The printer functions best and produces the best print quality when using stocks that have the correct:

- Size
- Weight
- Type
- Color

For more comprehensive information on paper stocks for Xerox printers, refer to Helpful facts about paper, 721P82493.

Paper weights

The DT 128/155/180 HLC supports the following range of paper weights: 16–110 pound / 60–200 gsm

Other paper weights should not be used.

The equivalent grams per square meter of 20 pound paper is actually 75 gsm. However, there is no standard 75 gsm paper. The available stock that is closest in weight to 20 pound paper is 80 gsm.

Special stocks

The following special stocks can be used with the DocuTech 128/155/180 HLC:

- Labels: Must be the type designed for high-speed printers and must meet the specifications described in the section above. Loading instructions are printed on all paper trays.
- Transparencies: Must be the type designed for high-speed printers and must meet the specifications described in the section above. Loading instructions are printed on all paper trays.
- Colored paper: Available in a variety of colors, colored paper has many uses, including calling attention to certain printed material, separating special sections, or dividing chapters of a report.
- Preprinted paper: May be letterhead, forms, or logos. (Refer to the “Helpful Facts about Paper” guide to verify that the preprinting inks used on your stock are the kind formulated for use in laser printers.)

- **Predrilled paper:** Has holes for use in binders or binder rings. Before loading predrilled paper, fan it to remove any loose plugs that could cause paper jams.
- **Perforated paper:** Have been pierced with one or more rows of holes to permit easy tearing or separating into sections. Read and follow the instructions on the ream packaging.
- **Precut or full tabs**
- **Carbonless paper:** Is paper that is treated or coated to produce an image under pressure (without the use of carbon paper). After opening, close and seal the original ream wrapper to store. Do not leave in paper trays overnight. Read and follow the instructions on the ream packaging.

General paper characteristics

When selecting paper, look for the following:

- **Low moisture content** (a paper to moisture ratio below 5.7 percent). Paper with higher moisture content may curl and jam.
- **Smooth surface**
- **Moisture resistant wrapping**
- **No defects** such as bent edges or uneven surfaces
- **Grain runs parallel** with the long side of paper

Graphical user interface overview

The graphical user interface (GUI) on the controller enables you to interact with the printing system. It contains windows, icons, and menus through which you can issue commands and perform operation and system administration tasks.

When the workstation controller is powered on and booted, the DocuSP Print Services main menu displays on the controller screen.

System software and job flow

This section describes how the system software processes are used as a typical job flows through the system.



NOTE: *There are no job flow differences between the High volume printer and the Production publisher configurations.*

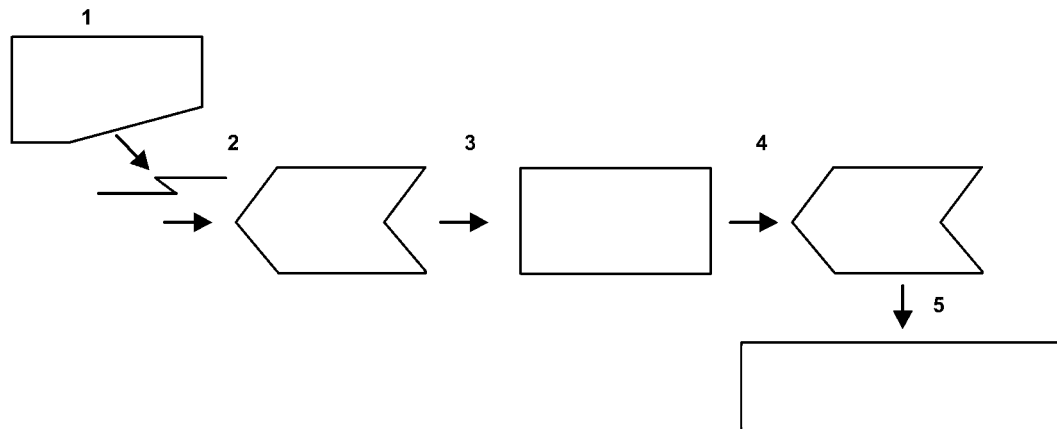

QTC0102A-TOR

Figure 2-1. Job flow

1. Job
2. Input Queue
3. Decomposer
4. Output queue
5. Printer

Job

The job and the job ticket (if applicable) are received from the network by one of the protocol gateways.

Input queue

The Job Pool Manager (JPM) process transfers the job into the input queue. The virtual printer name and job attributes are attached to the job. The job remains in the Input Queue until it can be printed; for example, “held” and “faulted” jobs reside in the input queue.

Decomposer

The Job Chooser reconciles the job attributes with the virtual printer attributes. Once the job is ready for print, the Job Chooser gives the job to the appropriate decomposer, PostScript or PCL.

Output queue

After decomposition, the job is stored in the output queue.

Printer

The marker transfers the job from the Output Queue to the printer. After the job has successfully printed, it is removed from the Output Queue and also from the Input Queue.

The printing process and job flow is different for PostScript, PCL, TIFF, ASCII, PDF jobs (that is, non-LCDS jobs) and for LCDS jobs.

**PostScript, PCL,
TIFF, ASCII, IPDS,
and PDF jobs**

When the job is sent from the application for printing, a print data file is created. This file becomes the job that is submitted to the printer for printing. The print data file and the job request are submitted to the selected queue. Jobs are processed by priority within the designated queue once the job reaches the queue from a given application.



NOTE: *IPDS and LCDS are not supported on the Production publisher configuration at this time.*

Printer overview

The printer receives data from the controller and prints the document according to the print options specified by the user. The printer also stacks and collates the printed output.

The printer system is available in two configurations:

1. High volume printer with inverter feeder/stacker and up to three feeder/stackers
2. Production publisher with a 2-tray interposer and finisher

High volume printer

The components, special features, and configurations of the Xerox DocuTech 128/155/180 HLC printer are shown in the following figures.

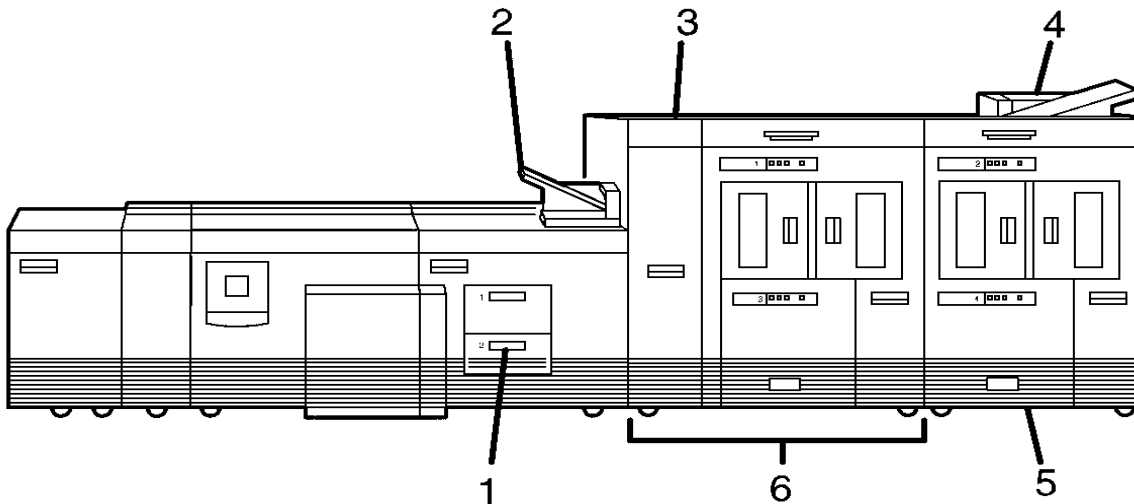

DPC0204A-SOR

Figure 2-2. Printer with inverter feeder/stacker + feeder/stacker (standard base configuration)

1. Feeder tray
2. Sample tray
3. Attention light
4. Purge tray
5. Feeder/stacker modules
6. Inverter feeder/stacker

Feeder/paper tray (High volume printer)

Multiple feeder/paper trays can be configured to feed paper for jobs in the most effective manner. For example, the trays can provide nonstop printing of a complex job that requires many paper stocks, or only a few stocks, by using the trays continuous loading capability. A different input tray can also be selected for each copy of a specific page in a print job, for example, to provide different paper colors for specific pages.

The printing system may have up to six feeder/paper trays: two processor feeder trays and two to four high-capacity trays. Four addressable input trays are standard with the system, and two additional high-capacity trays are optional.

**Processor feeder/
paper trays**

Two processor feeder/paper trays (trays 1 and 2) are located in the main part of the printer.

Trays 1 and 2 can handle paper sized from 8 by 10 inches / 203 by 254 mm to 9.02 by 14.02 inches / 230 by 356 mm.

**Feeder/paper tray
capacity**

Depending on your configuration, the feeder/paper trays have the following capacities, based on 20 pound or 80 gsm (grams per square meter) paper:

Tray 1: 1100 sheets

Tray 2: 600 sheets

Trays 3, 4, 5, and 6 (high-capacity trays): 2600 sheets each

An elevator moves each tray up or down when it is in use. In each tray, a control panel consisting of a button, indicators, and paper level displays controls the elevator tray and indicates its status.

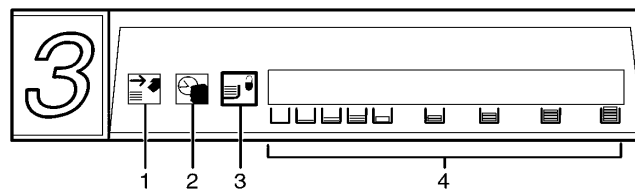

Figure 2-3. Feeder/paper tray control panel

1. Ready to Open indicator
2. Please Wait indicator
3. Tray Unlock button
4. Paper Level indicators

**Ready to Open
indicator**

Glows green when the tray can be pulled out and paper can be added to it.

**Please Wait
indicator**

Shows that the tray is in motion. This indicator is lit red when the Tray Unlock button is pressed, while the tray is lowering, and while the tray is rising. The indicator goes off when the tray elevator reaches its destination.

Tray Unlock button

Enables the tray to be opened.

- If the tray is in use when this button is pressed, the feed selection switches to the backup tray if one has been identified. Otherwise, printing stops.
- If the tray is in use and selected as a backup tray, pressing the Tray Unlock button causes the tray elevator to lower and the tray to be unavailable for auto switching.
- If the tray elevator is in the raised position and the tray is not in use or selected as a backup tray, pressing this button causes the elevator to lower with no effect on printing operations.

This button functions when the Please Wait indicator is off.

Paper Level indicators

Display the approximate quantity of paper in the tray. Each display shows paper by quarter reams up to one ream, and then by full reams. The green indicator appears above its Paper Level indicator.

Sample tray



NOTE: *High volume printer configuration only*

The sample tray, located on top of the printer, receives output such as transparencies, sample sheets from printing jobs, prints from system files such as forms, and waste sheets that cannot be sent to the purge tray.

Monitor the sample tray and empty it when it contains 100 sheets. The system does not notify you when the tray is full.

Attention light



NOTE: *High volume printer configuration only*

An Attention light is mounted on top of the inverter module. This light either blinks or modulates (alternately brightens and dims) when the printer requires operator attention. The light has three states:

Off: No printer problems exist that require attention.

Steady light: A situation exists that needs attention soon.

Flashing: The printer has stopped and requires your attention immediately.



NOTE: *When the Attention light starts flashing, an explanatory message appears on the controller screen.*

Purge tray



NOTE: *High volume printer configuration only*

The purge tray is located on top of the last feeder/stacker module. Aborted sheets (for example, damaged sheets or sheets cleared after a paper jam) are sent to this tray. The purge tray should be emptied when it has received 100 sheets of paper.

The system does not notify you when the tray is full.

Inverter feeder/stacker



NOTE: *High volume printer configuration only*

Each output feeder/stacker has offsetting capability and a capacity of 2500 sheets of 20 pound or 80 gsm paper.

This capacity does not apply to 11 by 17 inch and A3 papers. Because of the additional weight these large sheets add to the bins, each bin is restricted to hold only up to 1500 sheets of A3 or 11 by 17 inch papers, for safety reasons.

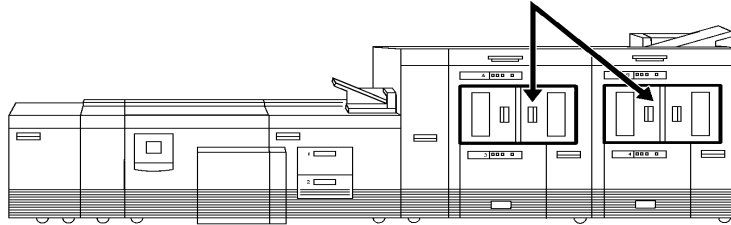

Figure 2-4. High capacity stackers (HCS)

The stackers can stack the printed output in the bin three ways:

1. Directly onto the bin platform.
2. Into a container that is set on top of the bin platform.



NOTE: *The stacking capacity is approximately 100 to 150 sheets less when stacking into a container.*

3. Onto a pallet without a container (for paper sizes 11 by 17 inches or A3 only).

Using the stacking windows on the user interface, you can select the level to which paper will be stacked in the HCS.

A stacking elevator maintains the paper at the proper level for stacking and lowers the stack for unloading. An offset mechanism offsets printed sets toward the front or back of the HCS bin.

The elevator platform lowers under the following conditions:

- The bin capacity has been reached.
- A selection to lower the platform is entered at the printer control console or a user interface window.
- The job being printed reaches a designated unload boundary.

Each HCS bin has unlinked double doors to give you easy and safe access for unloading output from the printer.

The elevator bin platform automatically rises when the doors are closed after the stacker has been unloaded.

Each stacker bin has a control panel consisting of buttons and indicators.

Bin control panels on stackers

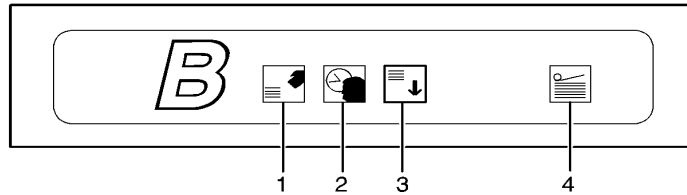

Figure 2-5. High capacity stacker bin control panel

1. Ready to Unload indicator on stacker bins
2. Please Wait indicator on stacker bins
3. Bin Unload button on stacker
4. In Use indicator on stacker bin

**Ready to Unload
indicator on stacker
bins**

When this indicator glows, you can remove printed sheets from the stacker bin.

**Please Wait
indicator on stacker
bins**

When this indicator glows, the elevator is in motion. This indicator turns off when the platform reaches its destination.

**Bin Unload button
on stacker**

Lowers the bin elevator.

- If the bin is in use when this button is pressed, the printed pages begin stacking in the other stacker bin, if auto switching has been enabled.
- If the bin is not in use, pressing this button does not affect printing operations.

**In Use indicator on
stacker bin**

When this indicator glows, the bin has been made ready to receive output.

Feeder/stacker modules

The feeder/stacker modules contain the high-capacity feeder trays and the stacker bins. The printer may have up to four feeder/stacker modules (including the inverter feeder/stacker), containing feeder trays 3, 4, 5, and 6, and stacker bins A, B, C, and D. Each module contains one high-capacity feeder tray and one high capacity stacker bin.

**High-capacity
feeders**

The high-capacity feeder (HCF) trays are located in the bottom half of the feeder/stacker modules. Each HCF tray can hold up to 2500 sheets of 20 pound or 80 gsm paper.

The high-capacity feeder trays can handle paper sized from 8 by 10 inches / 203 by 254 mm to 17 by 14.02 inches / 432 by 356 mm.

Unlike the processor feeder trays, the HCF trays have Paper Level switches, which detect the position of the elevator to determine the fullness of the tray.

High-capacity stackers

The high-capacity stacker (HCS) bins are located in the top half of the feeder/stacker modules, accessed through double doors.

Two high-capacity stacker bins are standard, with up to two additional bins available as options (providing up to four bins total). Each bin holds up to 2500 sheets of 20 pound or 80 gsm paper.

More High volume printer configurations

In addition, the high volume printer is available with three or four feeder/stacker modules.

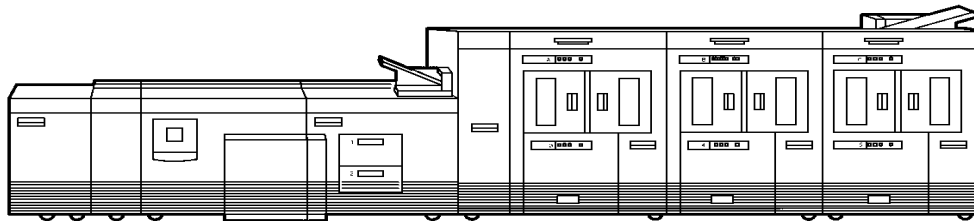

DPC0208A-SOR

Figure 2-6. Printer with inverter feeder/stacker + feeder/stacker + feeder/stacker

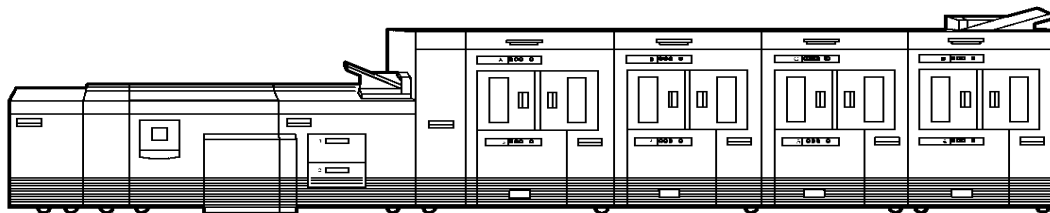
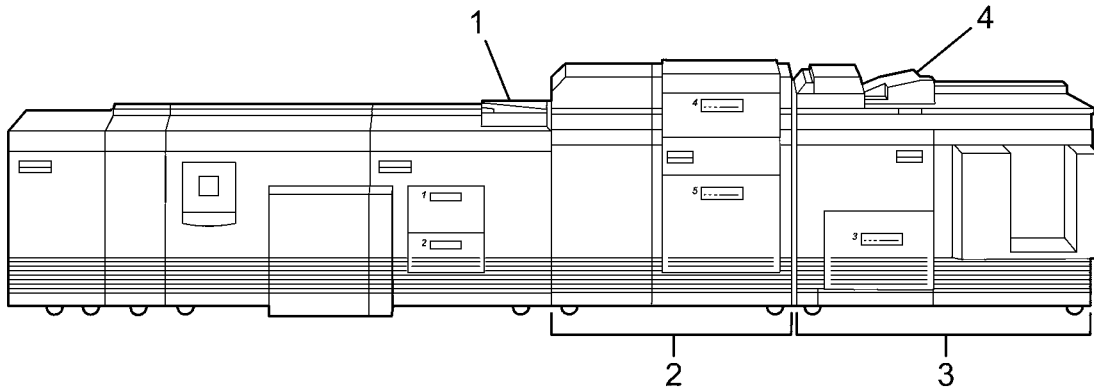

Figure 2-7. Printer with inverter feeder/stacker + feeder/stacker + feeder/stacker + feeder/stacker

The illustrations above show a High volume printer configuration with two feeder/stacker modules and a bypass transport, and a printer with three feeder/stacker modules and a bypass transport. With the bypass transport installed, the printer can support up to three feeder/stacker modules, including the inverter feeder/stacker.

Production publisher

The standard base components, special features, and configurations of the Xerox DocuTech 180 HLC production publisher printer are shown in the following figures.



DPC0204A-TOR

Figure 2-8. Production publisher: Printer + 2-tray interposer + stitcher/binder

1. Convenience tray
2. Interposer
3. Finisher
4. Top tray

Convenience tray

The convenience tray provides an area to place documents or other items while you are at the printer.

Interposer



NOTE: *Production publisher configuration only*

The two-tray Interposer module is located between the print engine and the Finisher. The Interposer inserts blank or preprinted sheets as required.

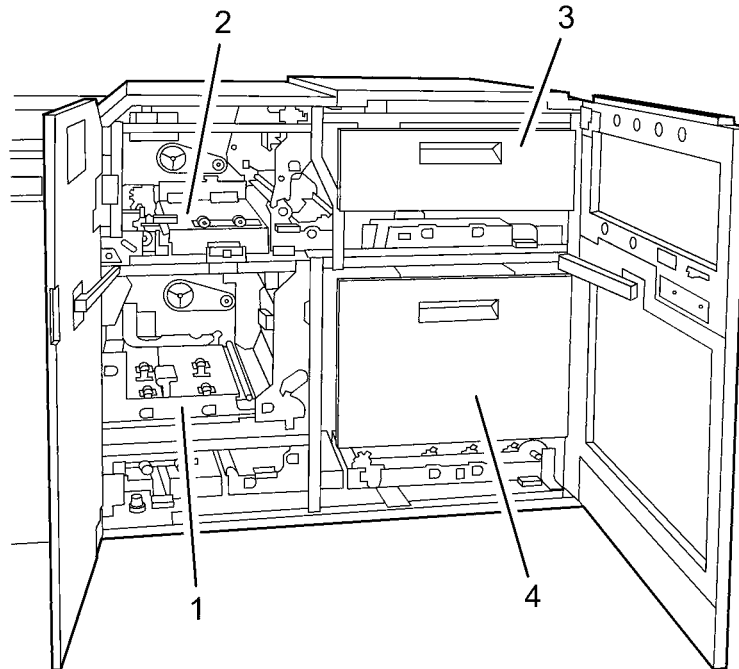

QTC0100A-TOR

Figure 2-9. Interposer (production publisher only)

The following lists the interposer components

1. Paper transport (lower)
2. Paper transport (upper)
3. Inserter tray
4. Feeder/inserter tray

Finisher



NOTE: *Production publisher configuration only*

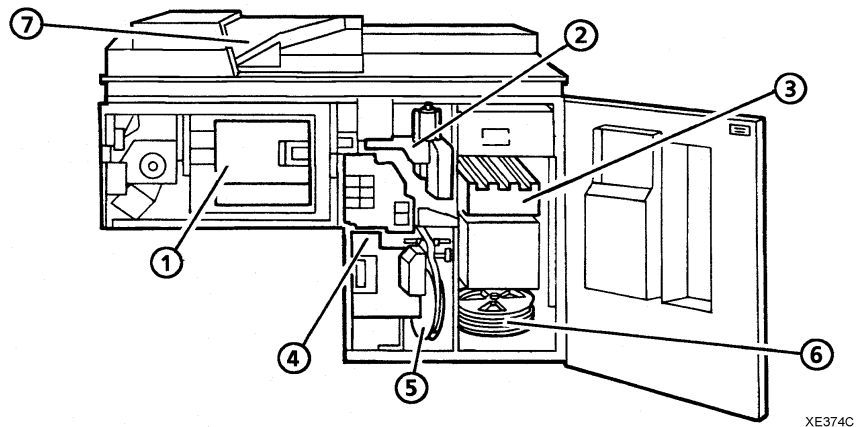

Figure 2-10. Finisher

In the finisher, prints can be collated, and stitched or bound, as required for a job. The following lists the finisher components:

1. Bindexer
2. Stitcher
3. Stacker
4. Binder
5. Binder tape reel
6. Stitcher wire spools
7. Top tray

The bindexer



NOTE: *Production publisher configuration only*

The bindexer is a three-bin sorter that collates the pages of each print set. As the pages of the print set are fed to the bindexer, the bindexer moves up and down to collate them.

The stitcher



NOTE: *Production publisher configuration only*

When the job requires stitched output, the stitcher cuts and inserts the wire stitches into each print set. The stitch length is related to such factors as the number of pages in the print set and the print stock weight. A single stitch can be placed in the portrait or landscape print position. Dual stitching is available for landscape and portrait prints. Stitch placement can be changed through the DocuSP software.

NOTE: *For more information about setting stitch placement, refer to the on-line help system.*

The stacker



NOTE: *Production publisher configuration only*

The stacker collects unfinished or finished stitched or bound jobs. When the stacker is full, or the job is completed, the stacker door opens and the stacker drawer that holds the prints comes out. After the stacker drawer is unloaded, the system retracts the drawer and closes the door. The stacker also can be unloaded during the printing cycle to check the quality of the print sets by changing the printer options.

NOTE: *For more information, refer to the on-line help system.*

The binder



NOTE: *Production publisher configuration only*

When a job requires bound output, a length of pre-glued paper tape is placed on a heated surface called the binder platen. The system aligns the pages of each print set before placing the set on the tape. Binder flappers then press the tape to the sides of the set. The combination of the heat in the binder and the pressure of the flappers glues the tape to the set.

NOTE: *For information about adjusting the binder tape registration and the binder tape length, refer to the on-line help system.*

The top tray



NOTE: *Production publisher configuration only*

Prints are delivered to the top tray because the prints are oversized or because the top tray was selected on the screen.

The bypass transport device is not available for this configuration (four feeder/stacker modules).

The printer is available in a Production configuration which includes a two-tray Interposer and the in-line Binder/Stitcher

Bypass transport

Function of the bypass transport

The printing system is available in several configurations, and may be configured with a bypass transport.

The bypass transport moves paper from the stacker to a third-party finisher such as a stitcher, booklet maker, tape binder, and so on. By making selections on the user interface windows, you can program the printer to send output to the bypass transport, which feeds the output to the finishing equipment.

Paper stocks supported on bypass transport

The bypass transport accepts all paper stocks on which the printer can print, and it accommodates simplex and duplex printing.

DFA support

The bypass transport meets the Xerox Document Feeding and Finishing Architecture (DFA) specifications. The system software supports DFA. However, in order for the bypass transport to function correctly, you need to set up finishing personality profiles to identify your finishing device to the printing system. (The customer support representative for your finishing device can give you the information you need to create a personality profile for your third-party finishing device.)

For information on marketing partners that provide solutions for support and interface with finishers, contact your local Xerox sales representative.

Bypass transport on the production publisher

Depending on the finisher configuration, the bypass transport is located inside the finisher module on the Production publisher configuration. Bypass transport function is the same as the external bypass transport module.



NOTE: *The Production publisher finisher is available with or without the bypass transport.*

Bypass transport on the High volume printer

Connected to the last feeder/stacker module. The bypass transport option enables third-party finishing devices to interface directly with the printing system. The bypass transport allows you to customize your printer for increased efficiency and specialized applications involving finishing.



NOTE: *Systems configured with the external bypass transport can have a maximum of two (2) feeder/stacker modules. See figure 2-13.*

7 by 10 inch enablement kit

The 7 by 10 inch enablement kit allows the printing system to print on 7 by 10 inch/178 by 254 mm paper size, with throughput speed of up to 206 PPM.

Paper paths

The paper path is the route that materials (paper, transparencies, labels, and so on) follow through the printer from the feeder trays to the output bins or finisher.

High volume printer paper path

The following figure shows the path the paper takes through the high volume printer.

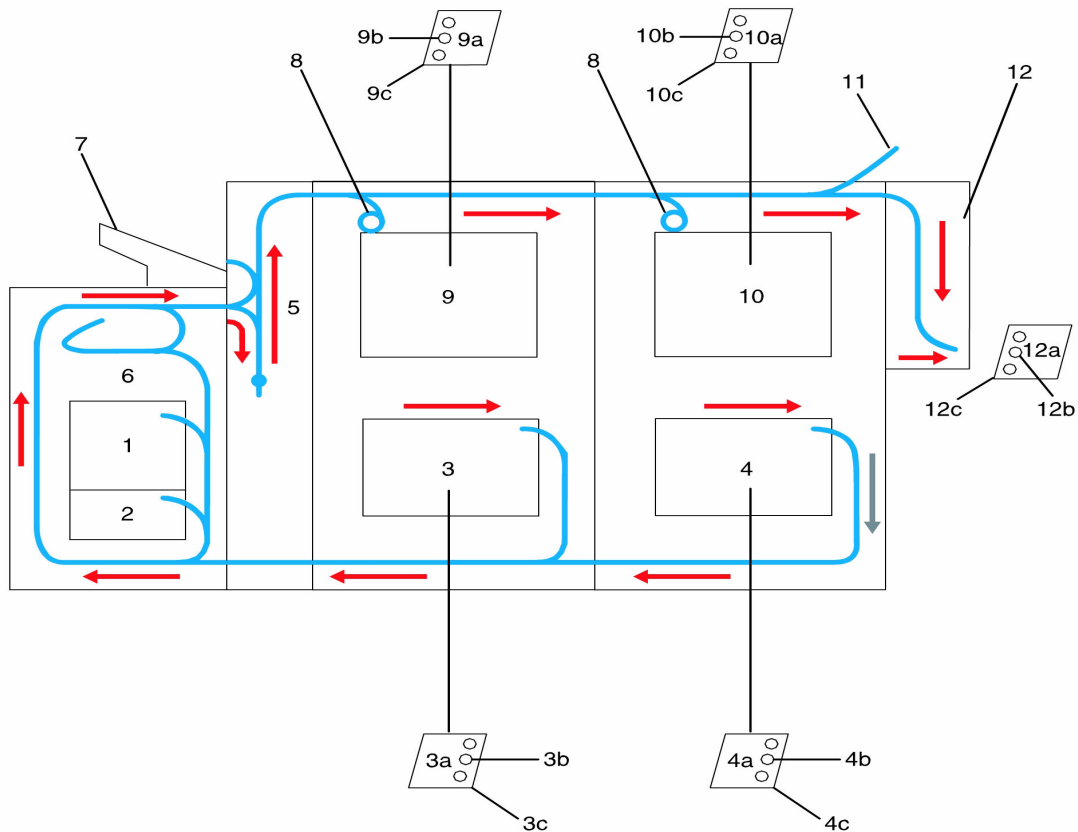

Figure 2-11. Route of paper through the high volume printer

1. Processor feeder tray 1
2. Processor feeder tray 2
3. High-capacity feeder tray 3
 - a. Side 1 of sheet leaving feeder tray
 - b. Drilled holes (on right edge)
 - c. Origin 0,0: portrait orientation

4. High-capacity feeder tray 4
 - a. Side 1 of sheet leaving feeder tray
 - b. Drilled holes (on right edge)
 - c. Origin 0,0: portrait orientation
5. Paper inverter
6. Duplex inverter
7. Sample tray
8. High-capacity stacker bin A
 - a. Side 2 of sheet stacked in bin
 - b. Drilled holes (on left edge)
 - c. Origin 0,0: portrait orientation
9. High-capacity stacker bin B
 - a. Side 2 of sheet stacked in bin
 - b. Drilled holes (on left edge)
 - c. Origin 0,0: portrait orientation
10. Purge tray
11. Bypass transport
 - a. Side 2 of sheet passing through bypass transport
 - b. Drilled holes (on left edge)
 - c. Origin 0,0: portrait orientation

Production publisher paper path

The following figure shows the path the paper takes through the production publisher.

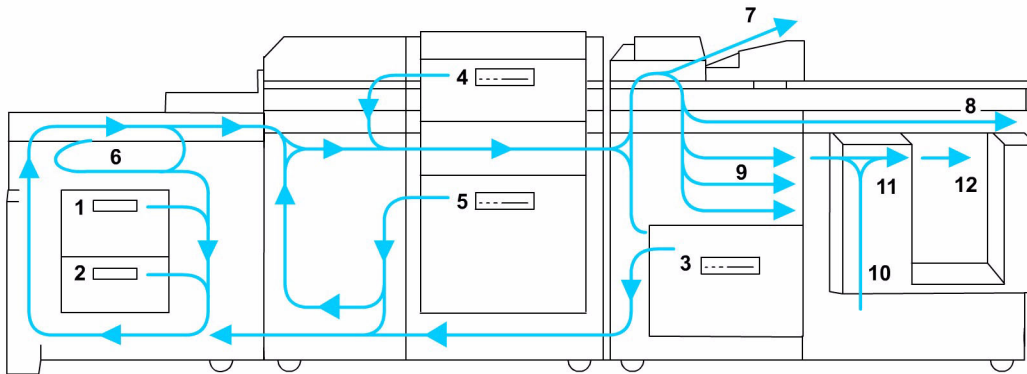

DPC0202A-TOR

Figure 2-12. Route of paper through the production publisher

1. Processor feeder tray 1
2. Processor feeder tray 2
3. High capacity paper tray
4. Paper inserter tray
5. High capacity paper tray
6. Duplex inverter
7. Purge tray
8. Bypass transport
9. Bindexer area
10. Bind area
11. Stitch area
12. Stacker area

Bypass transport paper path

The following figures show the paper path through the bypass transport, viewed from the front of the printer.

High volume printer bypass transport paper path

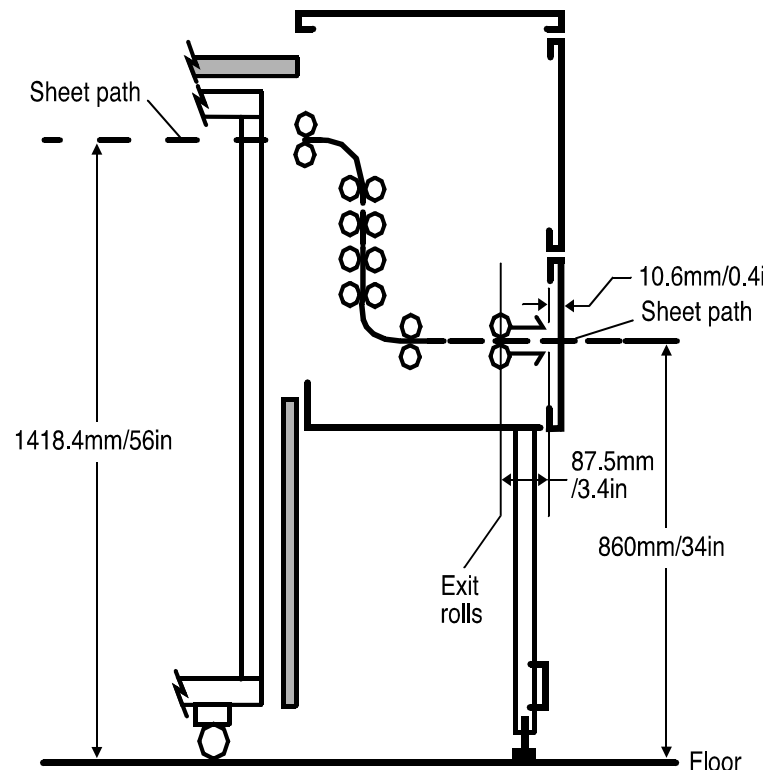

Figure 2-13. Bypass transport paper path (high volume printer configuration shown)

1. Sheet path
2. Exit rolls
3. Floor

The System

System Hardware

The basic hardware components of the DocuTech 128/155/180 HLC systems are the DocuSP controller and the printer.

The DocuSP controller

The DocuSP controller is the connection between you and the system. You communicate through the DocuSP software by selecting and managing the jobs displayed on the screen and sending them to the printer for production. The system also communicates messages and instructions to you on the Print Services interface screen.

The controller consists of a specially-configured workstation and uses proprietary Xerox hardware, firmware, and software.

Specifications can be obtained from your Xerox customer representative or by accessing the Setup, System Configuration feature on the DocuSP user interface.



NOTE: *Controller hardware configurations are subject to change to keep up with advances in technology.*

Controller overview

The controller receives LCDS*, IPDS, PostScript, and PCL data streams from a mainframe host or a workstation client, processes the data, and sends it to the printer. The controller also provides the printer with print data and commands and receives status information from the printer.

The controller consists of a workstation, which is run by the Sun Solaris Operating environment. Also resident on the controller is the Document Services Platform application software, known as DocuSP software, which manages all printing, diagnostic, and administrative functions on the printing system.

The DocuSP software includes a full-color graphical user interface, which enables you to interact with the printing system to set up and configure the system, to set up and implement system options, to run print jobs, etc.

Online Help (menus and buttons) provides access to online help that contains information when requested.



NOTE: *LCDS is not available on the Production publisher configuration at this time.*

Accessing DocuSP remotely (Remote Workflow)

Remote Workflow, a remote graphical user interface (GUI), is available for installation from a CD. Remote Workflow allows you to manage your DocuSP-based printers from a single PC or Sun workstation. You may set your preferences from the remote client to disable or enable some or all connections.

Remote Workflow allows you to configure the printers that you want to manage, and provides real time status of the printers. You may switch between the printers that you are managing, but you can display only one printer GUI at a time.

The remote client GUI looks and functions the same as the local DocuSP GUI on the controller.

Moving the controller

To ensure consistent performance and avoid any damage to equipment, follow these rules for placing the components of the workstation controller.

Do:

Use the controller stand that comes with your printing system equipment.

Keep the processor in an upright, vertical position.

Allow at least 6 inches / 152 mm of unobstructed space at the front and rear of the processor, so the fan and vents are not blocked.



CAUTION: *Do not place the monitor on top of the processor. Do not block any fan or vent on the front, sides, or rear of the processor.*

Do not:

Do not place the monitor and processor on a desk or table top.

Do not place the monitor on top of the processor.

Do not allow any piece of equipment to blow warm air into the air intake vents of the processor.

Do not place the processor on its side, or in any other position but the upright, vertical position achieved by using the controller stand.

Do not place the processor or monitor on top of the printer.

Tape drives overview

The DocuTech 128/155/180 HLC supports several types of tape drives that may be used to load resources (forms, fonts, etc.) or to submit offline LCDS print jobs.

A 26-track cartridge tape drive can be used only to import resources to the system disk. A 9-track or 36-track tape drive can be used to submit print jobs to the printer or to load resources.

The DocuSP Tape Client software enables transmission of data from a cartridge or open reel tape to the DocuSP controller via the Socket gateway.

The 4 GB external SCSI quarter inch cartridge (QIC) tape drive is an external device. The cartridge tape drive connects to the controller through the SCSI port on the processor back panel.

Like the diskette and DVD drives, this tape drive is not an input source for print jobs or for any other data or application. You can use it to load resource files, and the service representative uses it to load system maintenance files or to save diagnostic information.

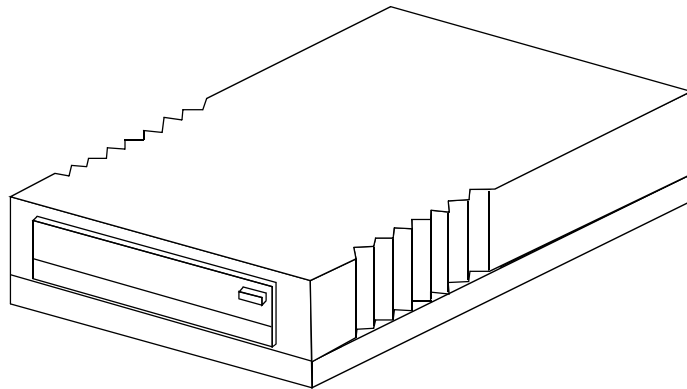

Figure 2-14. 26-track cartridge tape drive

36-track cartridge tape drive

An 18/36-track cartridge tape drive is an option. You can use this drive to load resources and to submit offline LCDS print jobs.

Peripheral cabinet (9-track and 18/36-track tape drives)

Some Xerox customers may already have a peripheral cabinet that houses a 9-track magnetic and an 18/36-track cartridge tape drive. If a peripheral cabinet has either of the following 18-track tape drives, they are not supported:

STK 4220 MOD 1 tape drive

STK 4220 MOD 2 tape drive

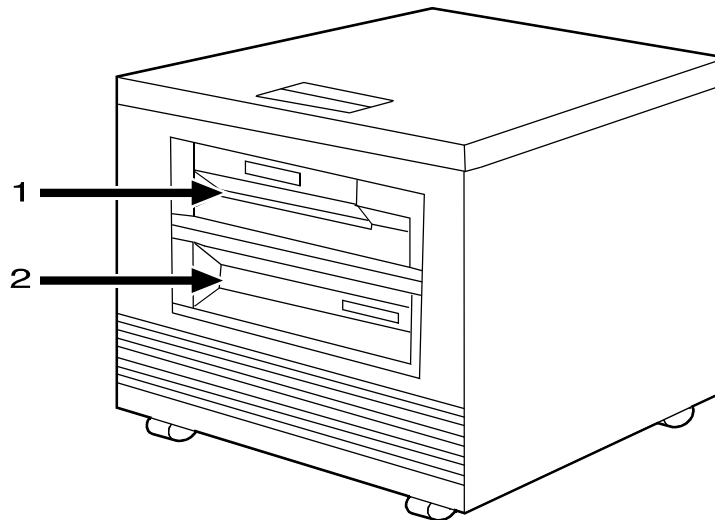

Figure 2-15. Peripheral cabinet

1. 9-track magnetic tape drive
2. 18/36-track cartridge tape drive

Paper sizing and print speed

The printer paper trays have edge guide sensors that detect paper length and width. The system selects correct paper trays for the print job based on the paper parameters, such as size, weight, color, or coating, specified in the job as follows:

- If an exact match is found, the print job continues.
- If an exact match is not found, the operator can specify in the job for the printer to do one of the following:
 - Stop printing the job and print an error sheet.
 - Print the data on an oversized sheet.

If you encounter any problems related to paper sizing, contact your lead operator or Xerox service representative.

Long and short edge feeding

To feed through the printer, the leading edge of the paper must be at least 10 inches long. Therefore, the following standard sizes of paper must be loaded so that sheets feed long edge first:

- 7 by 10 inch
- B5
- A4
- US letter
- B4
- US legal

The following papers, which have long edges greater than 14.33 inches / 364 mm must feed short edge first:

- A3
- US ledger or US tabloid



NOTE: *JIS B4 can be fed either long edge or short edge first.*

3 Routine maintenance

This section describes the routine activities you perform to maintain the reliability and productivity of your printer.

Cleaning and maintenance overview

Some printer components need to be cleaned periodically to help keep the system operating reliably, and to ensure that the print quality is consistent.

When supplies get low, an indicator will appear in the DocuSP Print Services window on the DocuSP controller. You should respond to the fault or message as soon as possible to avoid a printer shut down.

The system provides dry ink to the printer from a bottle located in the printer. When the screen displays an “empty” message, a full dry ink bottle must be installed.

Waste dry ink empties into a container located at the side of the printer, under the toner filter. When this container becomes full, it must be replaced.

Fuser lubricant must be added to the fuser reservoir in the printer when a “low” message on the screen directs you to do so. Fill the fuser reservoir at this time or the printer shuts down.

For information on cleaning the processor sensors, the reflecting surfaces, and the finisher sensors, refer to the *Problem solving* chapter.



NOTE: *The DocuTech HLC fuser oil is a specially blended fuser shield specifically for the DocuTech HLC systems.*



CAUTION: *The DocuTech HLC fuser shield must not be used in any other Xerox product.*



CAUTION: *Use only the DocuTech HLC fuser shield in the DocuTech HLC systems.*

Necessary Precautions

For your own safety and to protect the system, it is important to take the following precautions whenever you perform cleaning and replacement tasks.

- Use only the cleaning and replacement supplies that are

approved or recommended by Xerox. If you use other supplies, you may damage the system.

- Keep supplies in stock as listed in the *Service and supplies* chapter.
- Whenever you use or remove a part from the system, handle the part carefully. Note any informative labels on the system.
- Keep atomized and aerosol sprays away from the system.
- Pour cleaning liquids onto a cloth. Do not pour or spray liquids directly onto system parts.
- Before reinstalling a system part that has been cleaned with a liquid, ensure that the part is dry.
- Always use a drop cloth when replacing the dry ink bottle, highlight color container, or when adding fuser shield.
- Some parts of the system, such as the fuser, get hot during operation. To ensure that you do not burn yourself, be careful when working around these parts.



WARNING: *The fuser can reach a temperature of approximately 425°F (218°C). Exercise care to prevent burns when working near this area.*

Finisher precaution



NOTE: *Production publisher configuration only*

The system uses stitcher wire from two spools located below the stacker. Stitcher spool A is used for portrait, top corner stitches. When stitcher spool A is empty, it must be replaced with a new stitcher spool. Stitcher spool B is used for portrait dual stitches and landscape stitches.

To replace stitcher spool B, contact the Customer Support Center; refer to the section, “Calling for assistance”, in this guide.

To replace stitcher spool A, refer to the section, “Replacing the stitcher spool A”, in this guide.

The system applies binder tape from a reel mounted in the binder drawer in the finisher. You will need to replace the binder tape periodically.



WARNING: *All areas of the binder drawer, including the binder tape, are approximately 425°F (218°C) and may cause a serious burn to the operator. If the binder has been in a "Ready" condition, allow the binder to cool for at least one hour before attempting to clean the binder.*

Paper

You can add the same kind of paper to a tray when the supply is low without stopping the printer. You must have the same paper or stock loaded in two trays for the system to continue printing while you are loading the other tray.

Storing paper

It is important to store paper correctly. Temperature and humidity affect the way your printer processes paper.

Store paper in the cartons it came in. To reduce the possibility of moisture absorption, always place cartons on a wooden pallet or store them in a cabinet off the floor.

After removing the paper from its carton, always store it:

- In its wrapper
- On a flat surface
- In a closed cabinet
- In a cool, dry area
- In 68 to 76° F. / 20 to 24.4° C.
- In 35% to 55% humidity

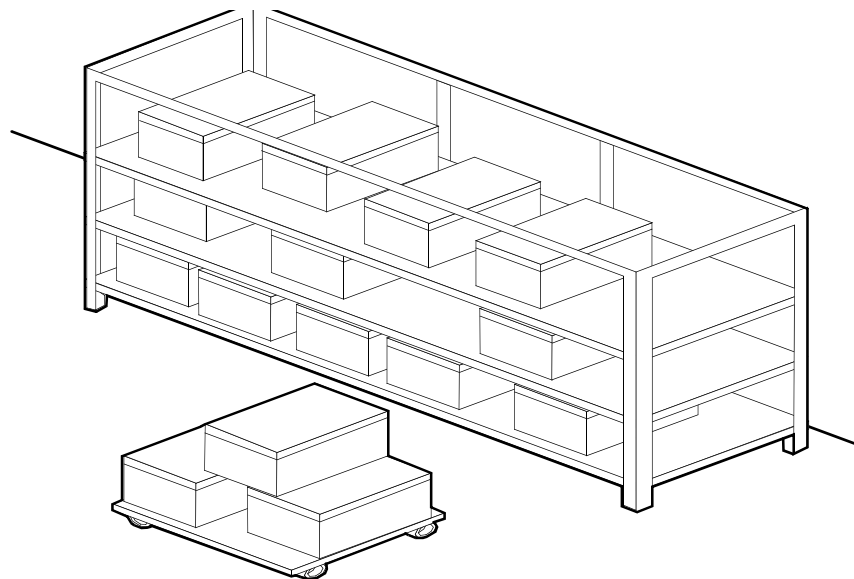

Figure 3-1 Storing paper correctly

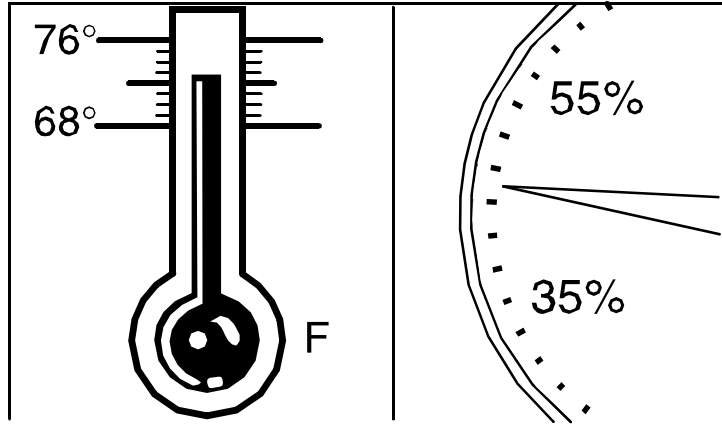

Figure 3-2 Recommended temperature and humidity for paper storage

Conditioning paper

Because temperature and humidity affect paper performance in the printer, you need to condition paper before using it. To condition paper, store it for a specified length of time in the same type of environment as your printer.

The length of time you should condition your paper depends on the amount of paper and the difference between the storage and operating temperatures.

Use the following chart to determine the number of hours needed to condition stacked cartons of paper.



NOTE: *The numbers in the top two rows indicate the temperature difference between the storage area and the operating environment, not actual room temperatures.*

Table 3-1. Paper conditioning

	Temperature difference between storage and operating areas						
Fahrenheit	10°	15°	20°	25°	30°	40°	50°
Centigrade	5.5°	8.5°	11°	13°	17°	22°	26°
Cartons	Hours needed to condition the paper						
1	4	8	11	14	17	24	34
5	5	9	12	15	18	25	35
10	8	14	18	22	27	38	51
20	11	16	23	28	35	48	67
40	14	19	26	32	38	54	75

Example: If you want to move ten cartons of paper from a storage area with a temperature of 90° F. to an operating area with a temperature of 70° F. (a 20° difference), you should do so at least 18 hours before using the paper.

Paper curl

Before the manufacturer cuts paper into sheets, it is stored on large rolls. After it is cut and packaged, it retains some of the curl from the rollers.

Although it is unnecessary to load paper with the curl facing up or down, best results occur when you are consistent. For example, if you open paper with the wrapper seam up, always load it in the tray that way.

Adding paper to tray 1 or 2

The following steps must be performed to add paper to tray 1 or 2.

1. Press the Tray unlock button on the front of the tray. Wait for the red "Please wait" light to go off.
2. When the green "Ready to open" light comes on, pull the tray out until it stops.

Steps 3 through 5 of loading paper into tray 1 or 2 are illustrated in Figure 3-3.

3. Press the green release tab.
4. Lift the metal handle on the feed belt and remove any paper under the belt.
5. Move the rear guide to the back of the tray.

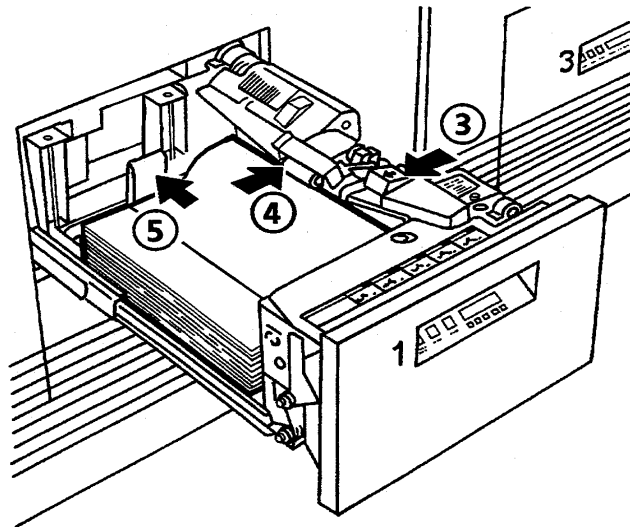

TA786A

Figure 3-3 Preparing the paper tray



NOTE: To load the paper correctly, refer to the label located on the inside panel at the front of the paper tray. Remove any damaged sheets from the top of the stack.



CAUTION: Do not load the paper above the red line. A jam could occur if too much paper is loaded in the tray.

6. Load the required paper into the paper tray. Load paper with the curl side facing down. Load Xerox paper with the package wrapper seam side facing up.



NOTE: When loading drilled paper, be sure to fan the edge where the holes are located.

7. Position the stack against the front right corner of the tray, as shown in Figure 3-4. This is indicated by the green arrow on the bottom of the tray.

For stock outside the recommended limits, refer to the "Technical information" chapter in this guide.

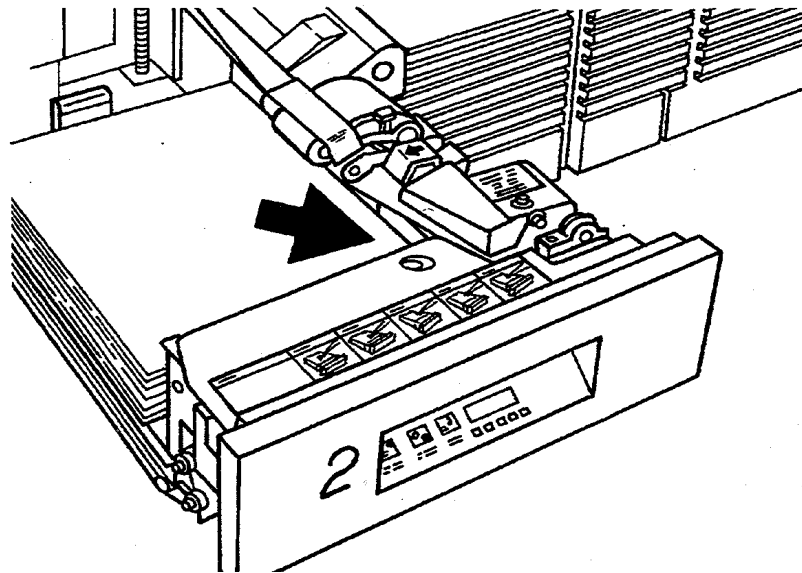

Figure 3-4 Positioning the stack

8. Move the rear guide forward until it touches the edge of the stack.
9. Lower the feed belt.
10. Close the tray slowly, but firmly, until it latches.

Using the custom transfer assist blade

The custom transfer assist blade in the printer assures good print quality for your jobs. A kit is available allowing you to customize the transfer assist blade for use with nonstandard paper sizes.

You cannot use the custom transfer assist blade for print jobs that use more than one paper size. In addition, the following paper lengths cannot use the blade:

In U.S. markets

- 11.1 to 11.4 inches/282 to 290 mm
- 11.8 to 12.1 inches/300 to 307 mm
- 13 to 13.5 inches/330 to 343 mm

In non-U.S. markets

- 11.1 inches to 11.4 inches/282 to 290 mm
- 11.8 inches to 12.1 inches/300 to 307 mm



NOTE: *With these paper sizes, transfer efficiency may be reduced.*



CAUTION: *To avoid damage to the photoreceptor, you must set the tray size with the transfer assist blade.*

Installing the custom transfer assist blade

The custom transfer assist blade comes in a package containing detailed instructions. Be sure you follow the instructions carefully.



CAUTION: *To prevent damage to the system, have your service representative show you the procedure before you attempt to customize and install a transfer assist blade for the first time.*

Setting tray size with the custom transfer assist blade

When you are using the custom transfer assist blade, you must set the tray length. Use the following two tables to determine the tray length setting to use.

Table 3-2. Tray length settings for custom transfer assist blades (U.S. markets)

Paper Size	Set Paper Size
11.5 to 11.7 inches/292 to 297 mm	11.7 inches/297 mm
12.1 to 12.9 inches/307 to 328 mm	13 inches/330 mm
13 to 13.9 inches/330 to 353 mm	14 inches/356 mm

Table 3-3. Tray length settings for custom transfer assist blades (Non-U.S. markets)

Paper Size	Set Paper Size
10 to 10.9 inches/254 to 277 mm	11 inches/279 mm
11.5 to 11.6 inches/292 to 294 mm	11.7 inches/297 mm
12.1 to 12.9 inches/307 to 328 mm	13 inches/330 mm

Adjusting for paper curl

Each sheet of paper has a natural curve called the curl. Storing or using the paper under humid conditions may increase the curl. When too much curl causes paper handling problems, adjust the decurler in the processor. The decurler flattens the paper after fusing.

Measuring the paper curl

1. Program and print five 1-sided, 8.5 x 11 inch (216 x 279 mm) sheets to the top tray.



NOTE: *Keep the image toward you, as shown in Figure 3-5.*

2. Measure the amount of curl in the prints by holding the five prints in the top center of the short edge.

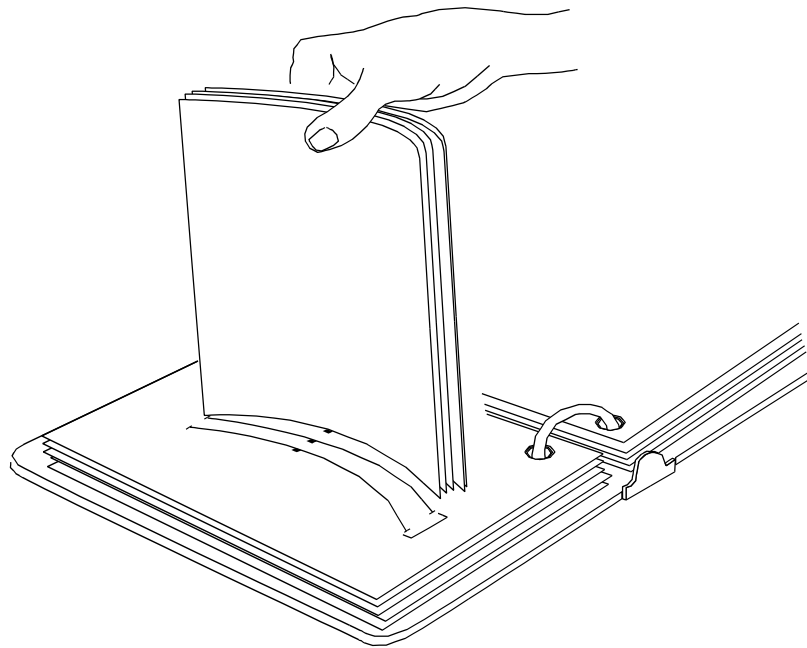

Figure 3-5 Measuring the paper curl

3. Place the bottom edge of the prints over the paper curl measurement chart in this guide.
 - If the print curl on the printed paper measures between +1 and - 2, do not change the decurler setting.
 - If the curl is between +2 and +3, or - 3 and - 4, refer to the procedure, "Adjusting the decurler lever," in this section.



NOTE: *Superior performance for greater than substance 32 (120 g/m²) can be achieved between +1 and -1 curl.*

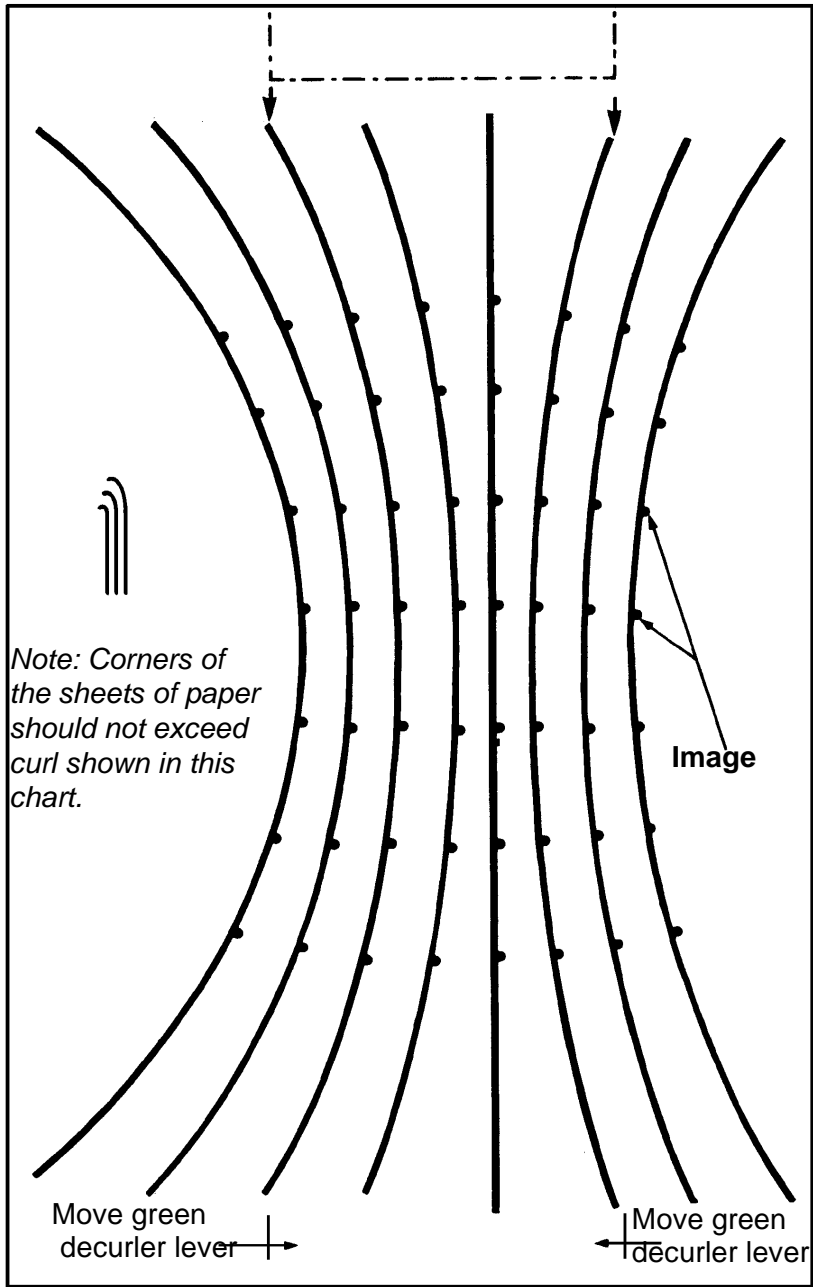

Figure 3-6 Measuring the paper curl

Adjusting the decurler lever

Perform the following steps to adjust the decurler lever.



CAUTION: *Do not use any paper that is not suitable for system use.*

1. Open the right door of the processor.
2. Locate the decurler lever in area 7 of the paper path, as shown in the figure below.

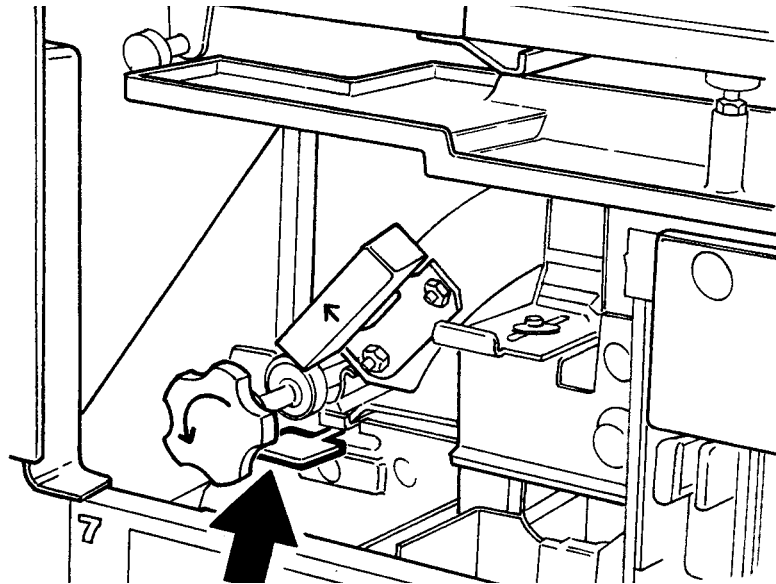

Figure 3-7 Locating the decurler lever

3. If the print curl is +2 or more, move the green decurler lever to the right.
4. If the print curl is -3 or more, move the green decurler lever to the left.
5. If the decurler adjustment does not eliminate the paper curl problem, or for other curl problems, turn the stack of paper over in the paper tray.
6. If there is still a curl problem, perform steps 1 to 4 again.



NOTE: *A final solution to the curl problem may be to load a new ream of paper.*

7. Close the processor door.

Maintaining the printer

A screen message is displayed when it is necessary to replace system supplies. To ensure that the system runs efficiently, replace the supplies as soon as possible.

Replacing the black dry ink bottle

When directed by a screen message, replace the black dry ink bottle. If the bottle is not replaced, the printer will eventually stop, and it will not operate until a new bottle is installed.



CAUTION: *To prevent dry ink spills, remove the bottle only when directed to do so by a message on the screen.*



CAUTION: *Do not use warm or hot water, or general cleaning solvents to remove dry ink from your skin or clothing. The heat or solvent will set the dry ink and make it difficult to remove.*



CAUTION: *If any dry ink should get on your clothes, brushing with a dry paper towel or a stiff-bristled brush may remove the ink. If not, launder your clothes with detergent and cold water. Tell a commercial dry cleaner that the spot is dry ink or "toner" so that they will not use a solvent that will set the dry ink stain.*

Replace the black dry ink bottle

The following steps must be performed to replace the black dry ink bottle.

1. Open the front processor access door and locate the black dry ink bottle at the left side of the processor.
2. Place a drop cloth on the floor under the dry ink bottle area.
3. Remove the empty bottle by grasping the bottle handle. With a slow, firm motion, pull the bottle from the bottle guide.
 - a. Pull the empty dry ink bottle out until it stops.
 - b. Move the green handle to the unlatched position.
 - c. Remove the empty bottle and discard it.

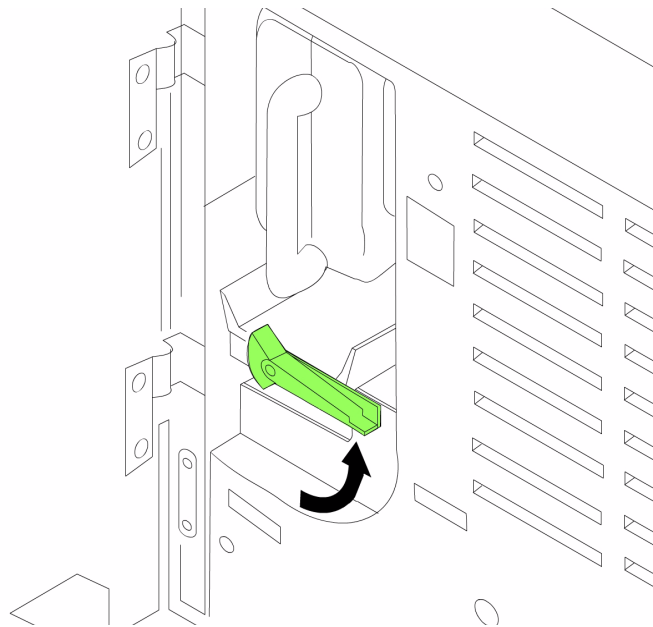

Figure 3-8 Removing the empty bottle

4. To insert a new bottle, place the bottle on the edge of the bottle guide.
 - a. With a slow, firm motion push the bottle into the dispense position over the hopper.
 - b. Turn a new bottle of dry ink upside down and shake the bottle thoroughly to loosen the contents. Insert the full bottle until it stops.

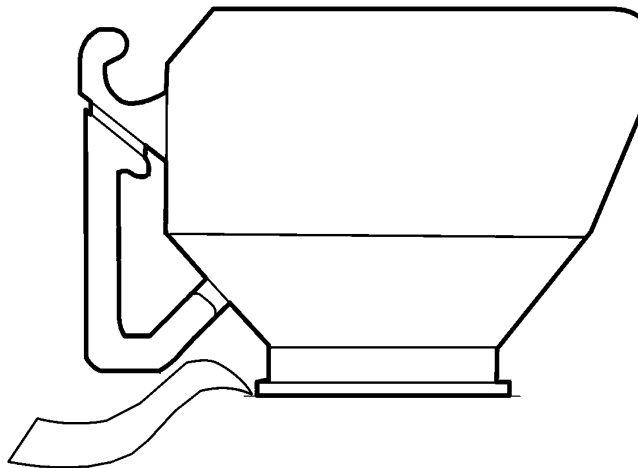

Figure 3-9 Inserting and latching the bottle

- c. Slide the full bottle all the way into the system.
- d. Hold the bottle in place with one hand and remove the

paper seal by pulling it toward you with the other hand. Discard the seal along with the drop cloth.

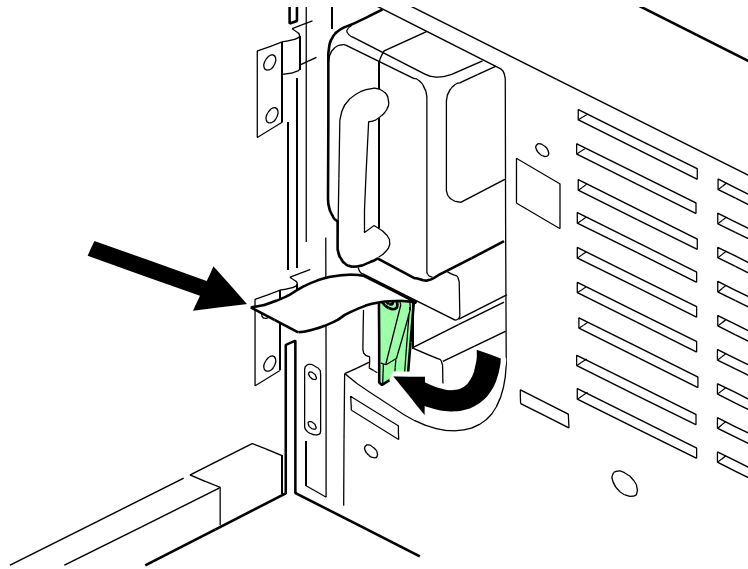

Figure 3-10 Removing the paper seal

5. Close the processor access door.



NOTE: *If any dry ink should get on your skin, wash with mild soap and cold water.*

Replacing the highlight color container

The highlight color container holds the color dry ink. When directed by a screen message, replace the highlight color container. If the highlight color container is not replaced, the printer stops, and it will not operate until the highlight color container is replaced.



CAUTION: *Do not use warm or hot water, or general cleaning solvents to remove dry ink from your skin or clothing. The heat or solvent will set the dry ink and make it difficult to remove. If any dry ink should get on your skin, wash with mild soap and cold water.*

If any dry ink should get on your clothes, brushing with a dry paper towel or a stiff-bristled brush may remove the ink. If not, launder your clothes with detergent and cold water. Tell a commercial dry cleaner that the spot is dry ink or "toner" so that they will not use a solvent that will set the dry ink stain.

1. Open the front processor access door and locate the highlight color container at the right side of the processor.
2. Place a drop cloth on the floor under the highlight color container area.

3. Remove the empty container by grasping its handle. With a slow, firm motion, remove the container.

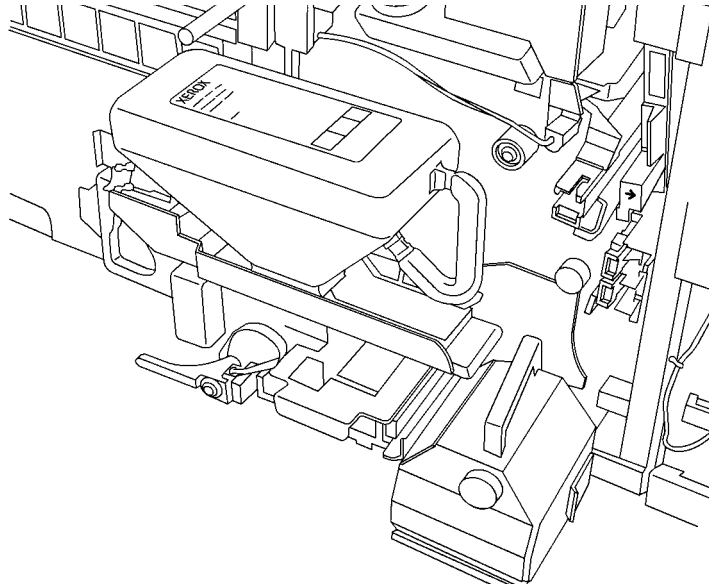

Figure 3-11 Highlight color container

4. Pull the container out until it stops.
5. Remove the container and discard it.
6. To insert a new bottle, place the bottle on the edge of the bottle guide. With a slow, firm motion, push the bottle into the dispense position over the hopper.
7. After the bottle is in the dispense position, remove the seal. You may encounter some resistance.
8. Close the processor door.

Changing the highlight color Customer Changeable Units

The highlight color Customer Changeable Unit (CCU) consists of the color dry ink bottle and supporting equipment. In order to change the highlight color or to service the wire module, you need to remove the highlight color CCU from the printer.

If you have more than one highlight color CCU, a CCU cart is provided to allow you to change and store the CCU. If you have only one highlight color CCU, a service cart is provided to allow you to remove the CCU for service.



CAUTION: *CCU carts should be used exclusively for changing and storing CCUs. You should always have at least one empty cart at your site if your printer has more than one color CCU. Do not attempt to remove or install a CCU without a cart.*



CAUTION: *Do not remove the CCU after a hard stop, such as caused by a paper jam, system crash or restart, or opening a door during printing, without first allowing the system to cycle up and continue processing for a proper recovery.*

Removing the CCU using the CCU cart

To remove the highlight color CCU from the printer:

1. If the printer is not cycled down, Pause the system before you open the doors and attempt to remove the CCU.
2. Open the printer doors and locate the color housing area in the center of the printer.
3. Open the top cover of an empty cart.
4. Push the cart up to the printer, lining up the yellow knob on the cart with the yellow recess on the printer inner cover.
5. Push the cart firmly against the printer until you can feel the two latch together.
6. Make sure the cart is level.
 - a. If the cart is not level, loosen the locknut holding the height adjustment knob in place.
 - b. Use the height adjustment knob to regulate the level.

- c. When the HLC unit is level, tighten the lock nut.

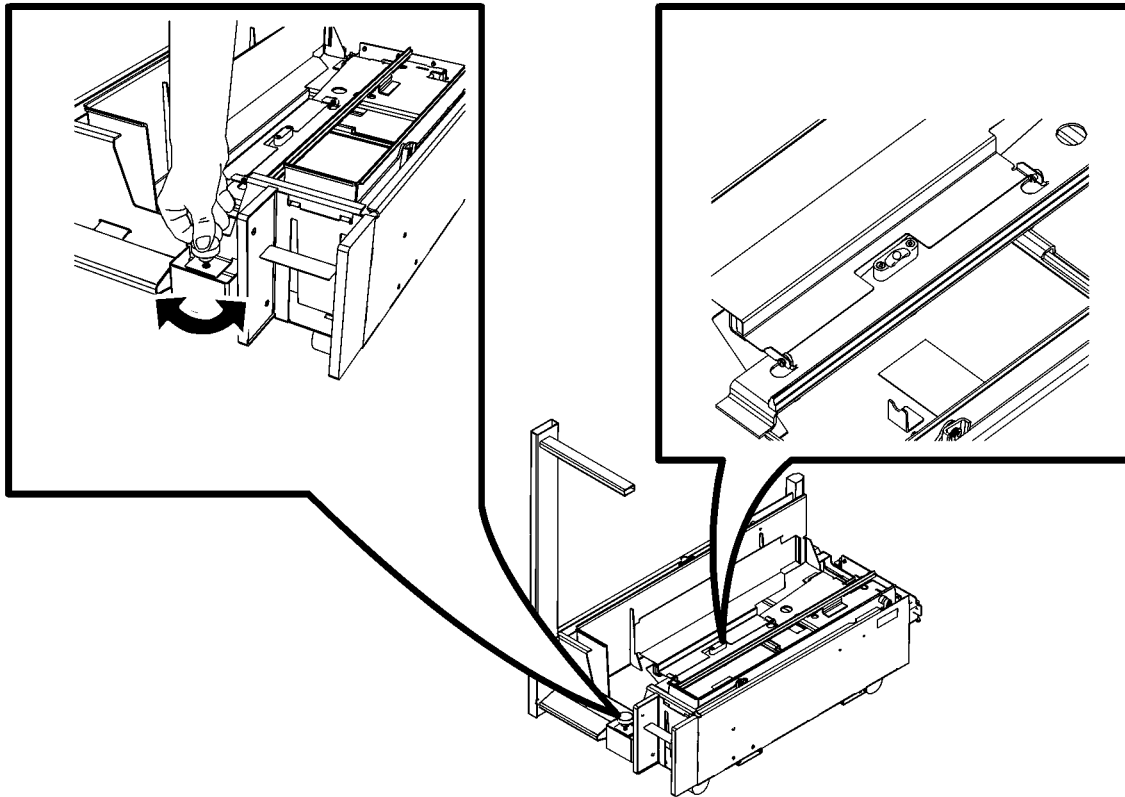

0CD00002A-SOR

Figure 3-12 Leveling the cart

7. Push down firmly on the cart pedal until you hear or feel the pedal catch. The pedal should stay locked down. The pallet within the cart is raised.
8. Unlatch the CCU by turning the photoreceptor backup roller handle clockwise for a quarter turn to an upright position.

5. Then, turn the yellow CCU handle a quarter turn clockwise.

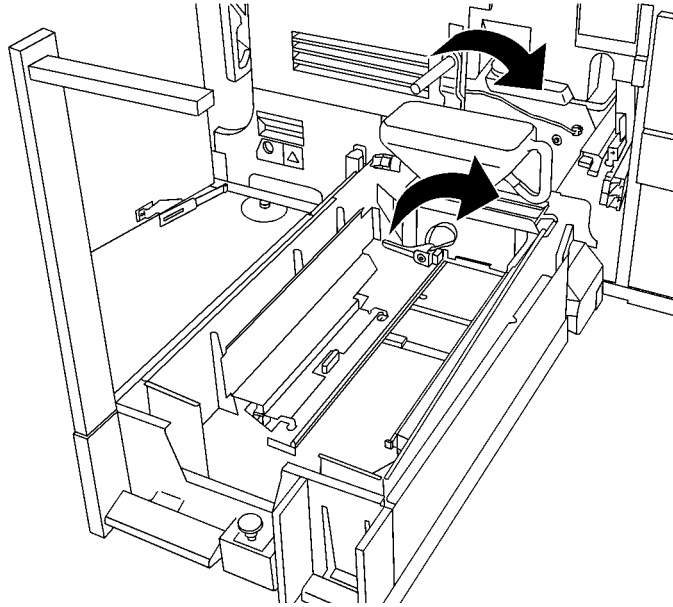
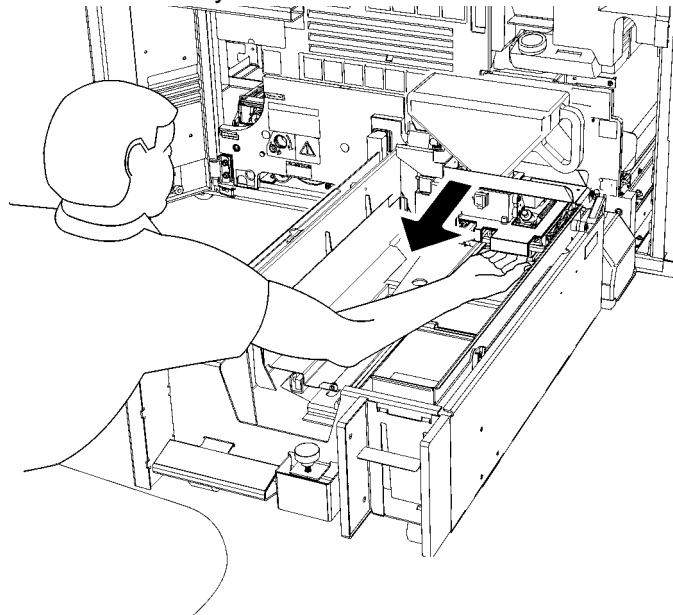

Figure 3-13 Unlatching the CCU

9. Using the metal flange of the color CCU, pull the CCU out of the printer until it is completely in the cart. The flange is located directly below the bottle.



OCD00005A-SOF

Figure 3-14 Removing the CCU from the printer

10. Push down firmly on the cart pedal until you hear or feel a click. The pallet, which now contains the CCU, is lowered into

the cart. If the pallet does not move, check that the CCU is all the way out of the printer and push down on the pedal again.

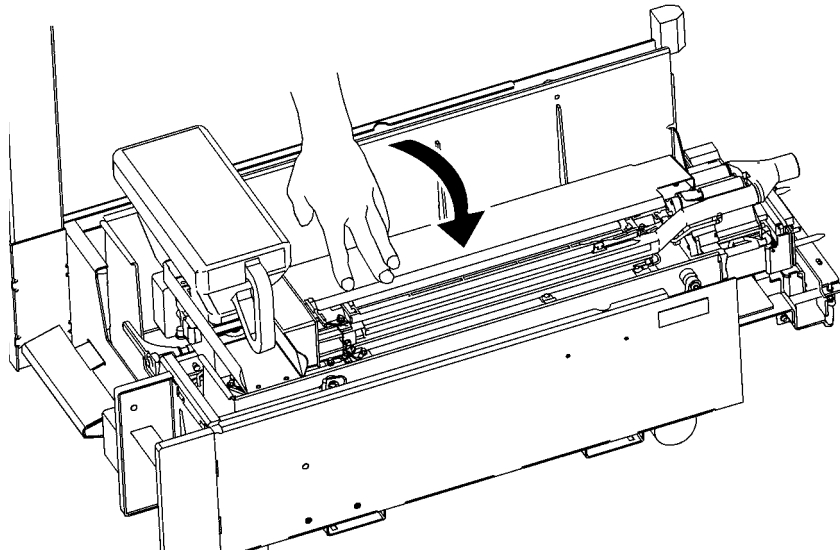

Figure 3-15 Closing the top cover

11. Close the top cover and store it.

Inserting a CCU

To insert a CCU, follow these steps.

1. Open the top cover of the cart containing the new color CCU.
2. Push the cart up to the printer, lining up the yellow knob on the cart with the yellow recess on the printer inner cover. Make sure the cart is level.

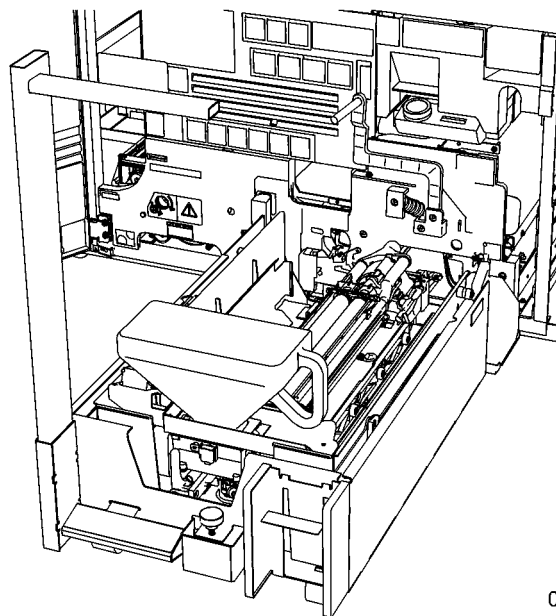

0CD0007A-SOR

Figure 3-16 CCU on cart

3. Push the cart firmly against the printer until you can feel the two latch together.

4. Push down firmly on the cart pedal until you hear or feel the pedal catch. The pedal should stay locked down. The pallet containing the CCU is raised.
5. Using the CCU metal flange, firmly push the CCU into the printer.
6. Turn the yellow CCU handle counterclockwise for a quarter turn. If it does not turn, check that the CCU is firmly seated in the printer.

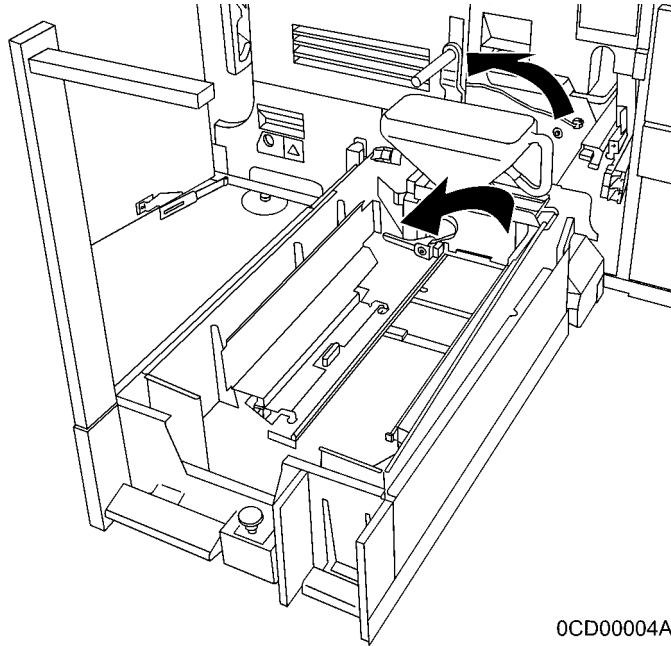

0CD00004A-SOR

Figure 3-17 Turning the backup roller handle counterclockwise

7. Turn the photoreceptor backup roller handle counterclockwise for a quarter turn.
8. Make sure that the CCU is completely inserted into the machine to prevent photoreceptor damage.
9. Push down firmly on the cart pedal until you hear or feel a click. If the pallet does not drop, check that the CCU is all the way in the printer and the pallet is released, then push down on the pedal again.
10. Remove the cart from the printer and close the cart top cover.
11. Close the printer doors.
12. Store the cart.

Storing the cart and CCU



NOTE: If any dry ink gets on your hands, wash them with soap and cold water. Heat sets the ink permanently. If any dry ink gets on your clothes, brush them with a dry paper towel or a stiff bristled brush. If this does not remove the ink immediately, launder with detergent and cold water. Tell the dry cleaners that the spot is dry ink for a printer, so they will not use a solvent that sets the stain.

When you are not using a cart and CCU, store them in a dry, dust-free area that has little variation in temperature and humidity. The storage area should have a similar temperature and humidity to the printer room. Maintain the temperature in the range of 60 to 80° F/15 to 26 C° and a relative humidity of 30 to 65 percent.

Removing the CCU using the service stand

Use the service stand to withdraw the highlight color CCU from the printer. Use this stand if you do not have a cart.

To set up the service stand:

1. If the printer is not cycled down, Pause the system before you open the doors and attempt to remove the CCU.
2. Open the printer doors and locate the color housing area in the center of the printer.
3. Place the service stand next to the developer housing.
4. By turning the jack screws, adjust the height of the front feet so that the alignment pins in the service stand are positioned just below the hole and the docking bracket. Tighten the lock nuts on the jack screws to lock the jack screws in position.

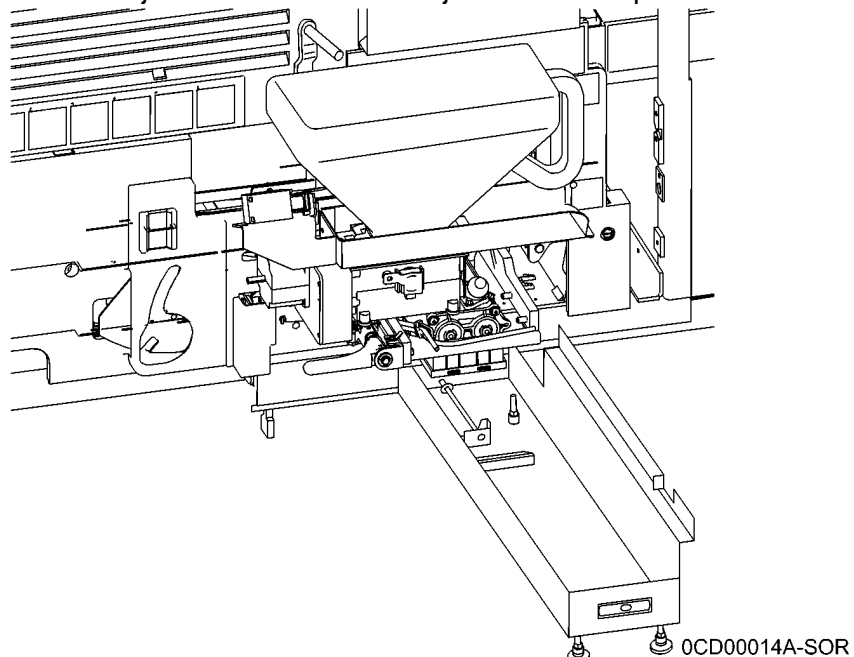
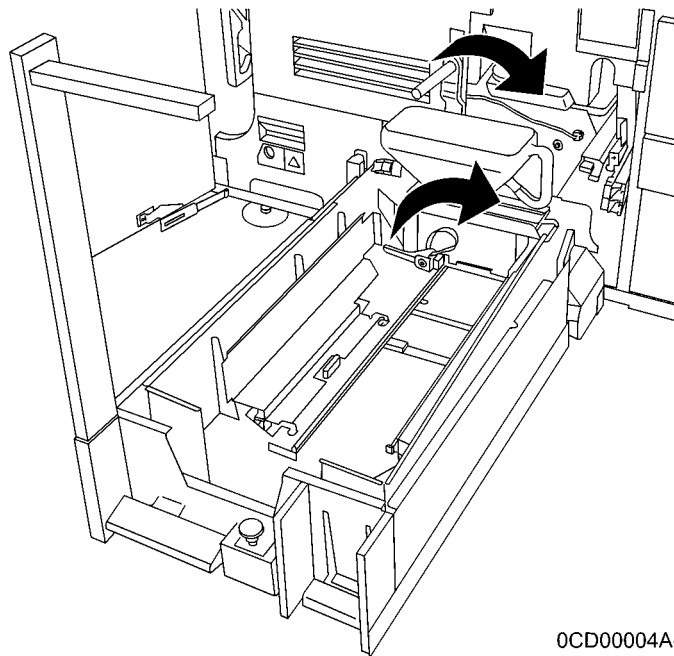

Figure 3-18 Service stand

5. Slide the stand toward the machine to engage the pins with the holes and the slot. The end of the service stand may need to be lifted slightly to ensure pin engagement.
6. With the service stand in position against the machine and the pins engaged in the docking bracket, engage the locking mechanism by applying a force forward on the lever and compressing the latch spring while turning it to the position shown.
7. Locate the pin squarely to the machine by ensuring that the two (2) locating pins in the service stand are in contact with the docking bracket.
8. With the service stand properly located to the machine and while observing the level, turn the rear jack screws to adjust the height of the service stand so that it is level.
9. Tighten the lock nuts on the jack screws to lock the jack screws in position.
10. Unlatch the CCU by turning the photoreceptor backup roller handle clockwise for a quarter turn to an upright position.



0CD00004A-SOR

Figure 3-19 Unlatching the CCU

6. Then, turn the yellow CCU handle a quarter turn clockwise.

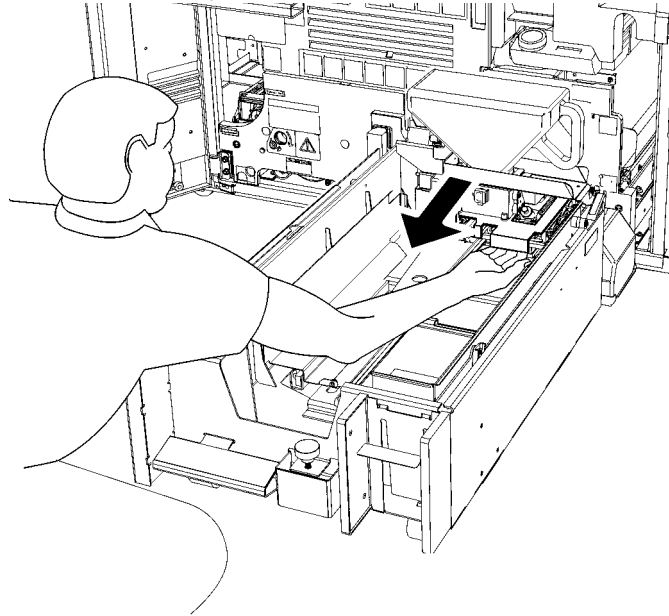

OCD00005A-SOF

Figure 3-20 Removing the CCU from the printer

11. Using the metal flange of the color CCU, pull the CCU out of the printer until it is completely in the stand. The flange is located directly below the bottle.
12. To replace the CCU, reverse the above steps.

Adding fuser shield

When directed by a message, add fuser lubricant as soon as possible. If it is not added, the printer stops after approximately 5,000 prints and not run until fuser shield is added. Please read the important note below.



NOTE: *In 2006, the formula for the DocuTech HLC fuser lubricant was changed to provide better image quality and to prevent image transfer. The new fuser formula is called Fuser Shield. The fuser blend and the fuser shield CANNOT be intermixed in a DocuTech HLC. To change from one fuser lubricant to another requires a service call and cleaning or replacing components. The two fuser formulas are identified with different color bottles and caps. Be sure the color of the cap of the bottle you are filling from matches the color of the cap already in the system. Fuser shield description: blue bottle, white cap with black printing. Fuser blend description: yellow bottle, black cap with white printing.*



WARNING: *The fuser area can reach temperatures of approximately 425°F (218°C). Exercise care to prevent burns when working in this area.*



CAUTION: *Fuser lubricant for other printers is not compatible. Do not use DocuTech and DocuPrint fuser agent in a DocuTech HLC system. Do not use DocuTech HLC fuser shield in a DocuTech 61xx or DocuPrint 1xx system. The fuser lubricants are not compatible and will contaminate the system.*

1. Open the processor doors.
2. Place a drop cloth on the floor under the fuser area.
3. Open the fuser drawer.
 - a. Locate the fuser drawer.
 - b. Grasp the green handle on the fuser drawer and pull it out until it stops.

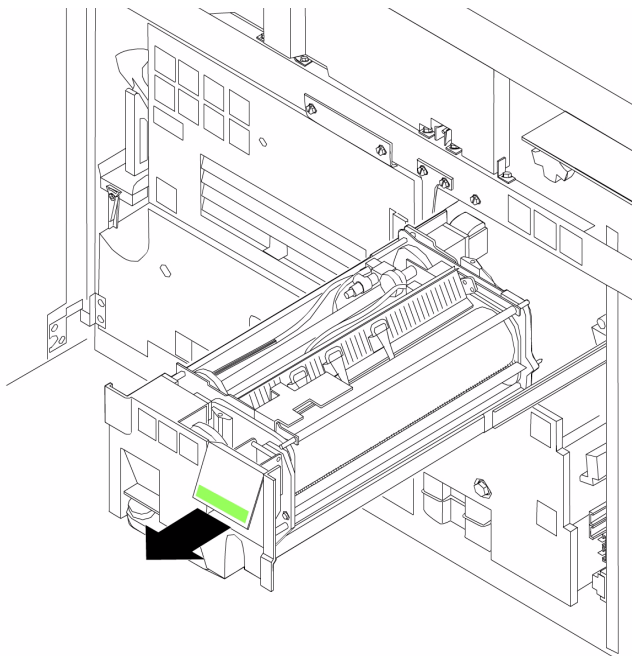

Figure 3-21 Opening the fuser drawer



WARNING: *Fuser lubricant contains silicone, which can cause irritation upon contact with the eye. Make sure that you wash your hands with soap and water after you finish this procedure.*



CAUTION: *Fuser lubricant can cause damage to the CCU if any of it is spilled into the unit. Use extra care to ensure that no fuser lubricant is dripped into the CCU.*

4. Wipe the fuser lubricant filler area to remove any residual lubricant.
5. Fill the fuser lubricant reservoir.
 - a. Pull the fuser lubricant reservoir out until it stops.
 - b. Remove the reservoir cap by turning it counterclockwise.

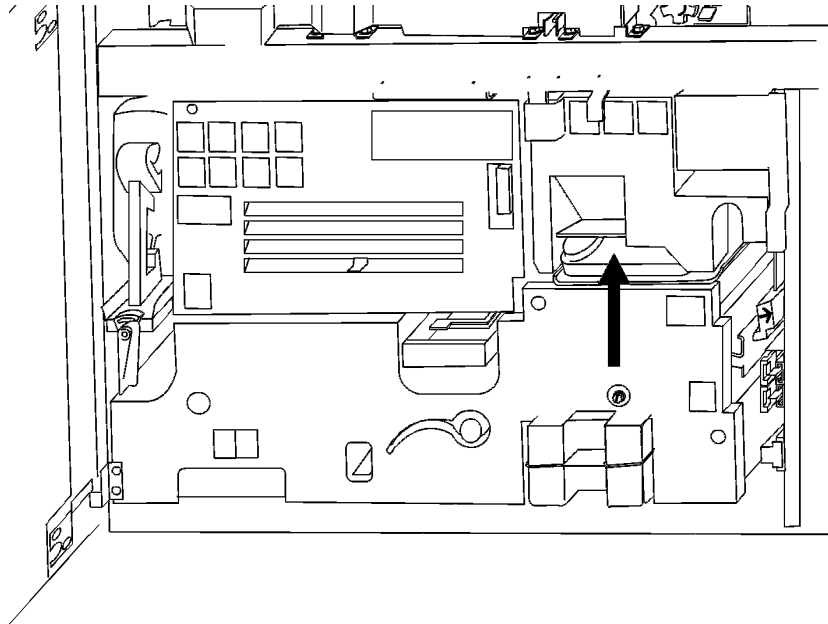

Figure 3-22 Preparing to add fuser blend



WARNING: *Fuser lubricant spills cause the floor to be slippery. If any fuser lubricant is spilled onto the floor, it must be removed immediately.*

- c. Open a new box of fuser lubricant and remove a bottle. Remove the cap from the bottle of fuser lubricant.
- d. Carefully pour the fuser lubricant into the reservoir until the level reaches the MAX line. Avoid spilling the fuser lubricant or overfilling the reservoir.



CAUTION: *Do not push the fuser lubricant bottle into the reservoir with excessive force. There is an anti-splash seal in the reservoir that could be damaged.*

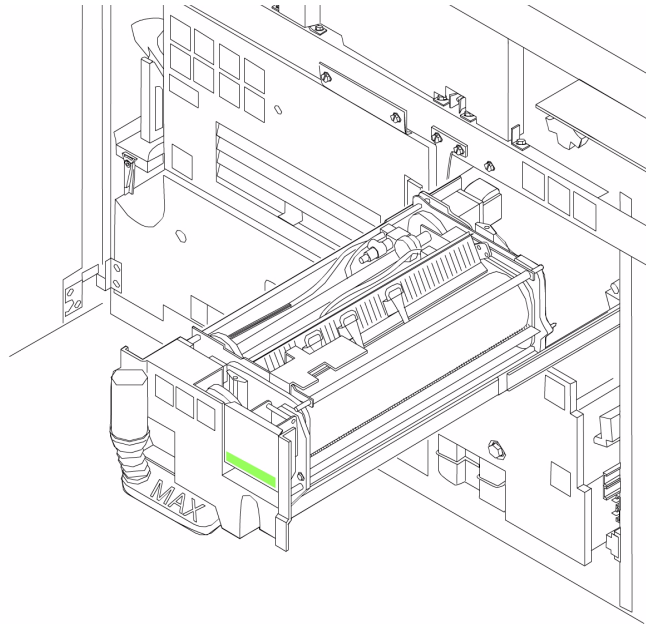

Figure 3-23 Adding the fuser blend

- e. Replace the reservoir cap by turning it clockwise approximately one full turn. Do not overtighten the cap.
 - f. Inspect the area around the fuser to ensure no fuser blend was spilled. Clean as required.
 - g. Push the fuser blend reservoir in until it stops.
- 6.** Push the fuser drawer in until it latches into place.

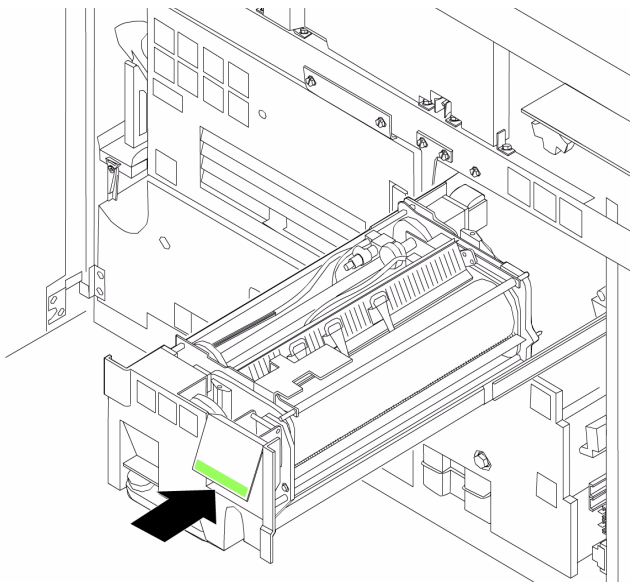

Figure 3-24 Closing the fuser drawer

7. Close the processor doors.

The fuser blend message disappears after the system makes approximately 20 prints.

Waste containers

The waste containers in the DT 128/155/180 HLC collect dry ink and developer after it has been used by the printer. When a container becomes full, it must be replaced or the printer eventually stops printing. This section contains the procedures for replacing the toner and developer waste containers.

Replacing the 128/155/180 HLC developer waste container

To replace the developer waste container:

1. Open the processor doors and locate the dry ink cartridge at the lower center of the printer. The developer waste container is located below and to the right of the color dry ink bottle.

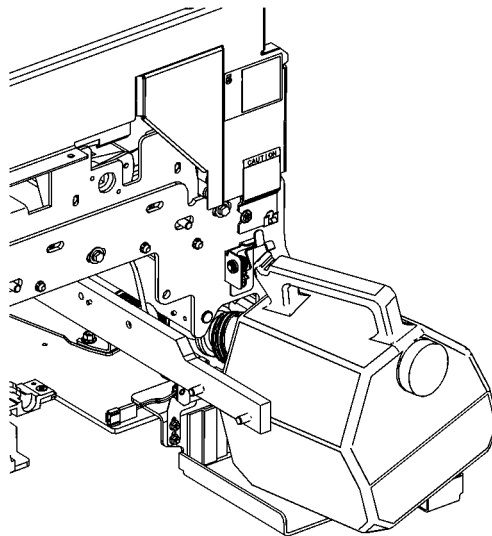

0800009A-SOR

Figure 3-25 HLC developer waste container

2. Using your right hand, grasp the container by the handle on top. With your thumb, depress the latch located above the frame of the machine. Lift the edge of the container from the tray and remove. Unscrew the cap from the front of the waste container and use it to close the open end of the waste container.
3. Discard the waste material and container appropriately.

4. Insert the new waste HLC developer waste container into the transport assembly. Push the retainer out of the way with your thumb. Continue seating the new waste container onto the tray and release the container latch.
5. Close the processor doors.

Replacing the 128/155/180 toner waste bottle

To replace the toner waste bottle:

1. Open the HLC module door.

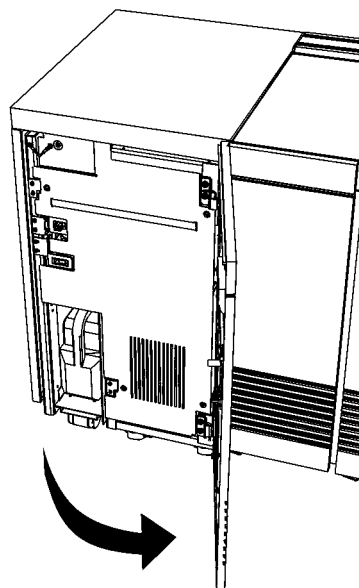

0CD00010A-SOR

Figure 3-26 Opening the HLC module door

2. Remove the toner waste bottle.
3. Remove the flat cap from the top front of the bottle.

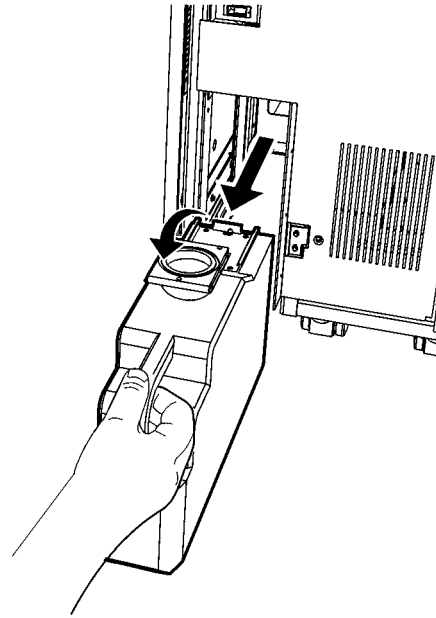

0CD00011A-SOR

Figure 3-27 Flat cap on waste bottle

4. Place the flat cap on the round bottle opening and snap it down. This prevents spillage when discarding the bottle.
5. Discard the waste material and container by placing the container in the trash.
6. Obtain a new bottle and open it, placing the cap at the front of the bottle and snapping it down.
7. Insert the new bottle into the waste module.

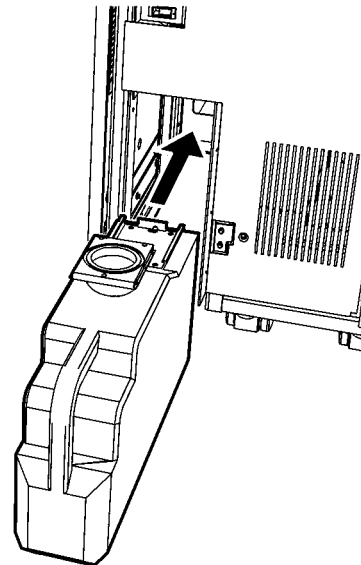

0CD00012A-SOR

Figure 3-28 Inserting a new waste bottle

8. Close the HLC module door.

Wire Module Removal and Replacement

Replace the wire module only when directed to by the Customer Support Center.



CAUTION: In the following instructions, do not pull on the locating arm of the developer housing. A bent or damaged locating arm can cause component damage or image quality artifacts.



Do not touch the Electrostatic Voltage (ESV) mounted to the top of the developer housing when removing the wire module. The ESV is fragile, and susceptible to damage from electrostatic discharge.

To remove the wire module:

1. Open the processor doors.
2. Using the CCU cart or service stand, slide the HLC developer module out of the printer. Refer to the procedures on using the CCU cart or service stand.

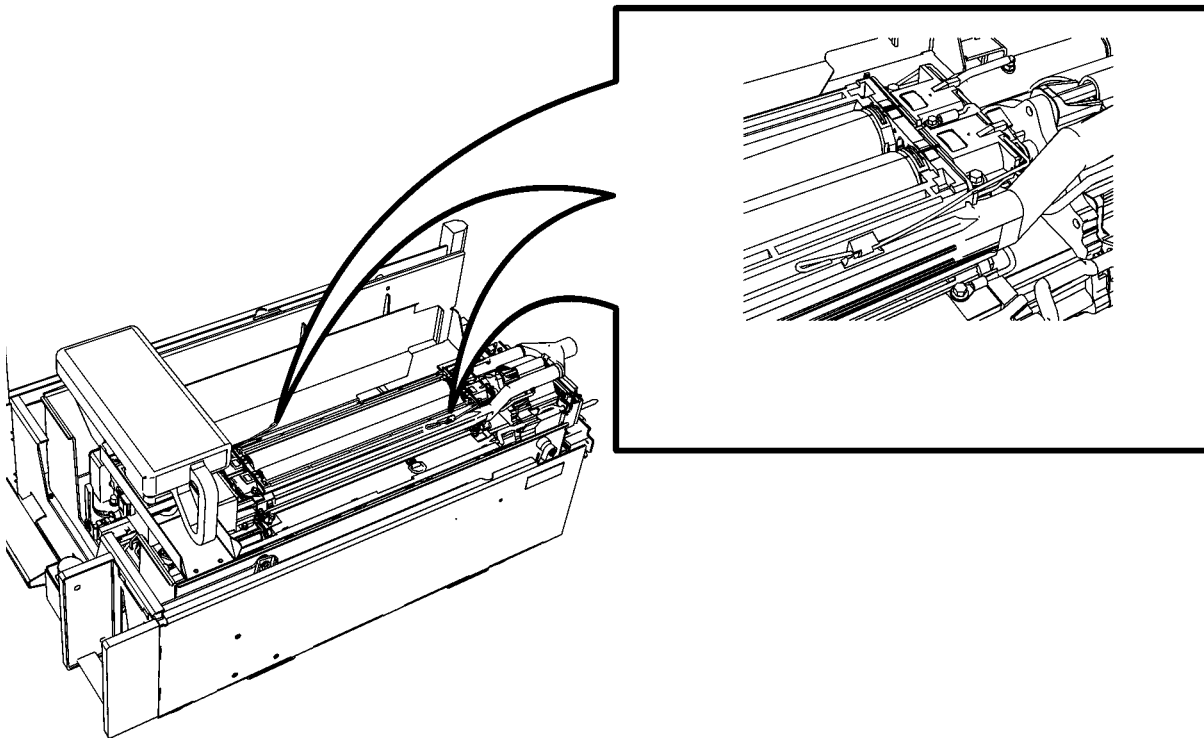

0CD00013A-SO

Figure 3-29 Wire module retainer springs

3. Release the wire module retainer springs. There is one at each end at the front and back of the developer housing.



CAUTION: Handle the wire module with care since the wires can be damaged or broken easily. Do not touch the donor rolls. Touching the roll surface with your fingers can contaminate the surface, causing image quality problems.

To replace the wire module:

1. Position the wire module on the HLC developer module.
2. Snap the wire module retainer springs behind the tabs.
3. Slide the HLC developer module into the machine.
4. Latch the CCU into place.
5. Remove the cart or service stand.
6. Close the doors.

Cleaning the system and its components



NOTE: Follow the procedures in this section only when directed by Xerox Customer Support center personnel.

Cleaning tasks consist of the following:

- Cleaning the 18/36-track cartridge tape drive
- Cleaning the 26-track cartridge tape drive
- Cleaning the DVD drive
- Cleaning the diskette drive
- Cleaning the sensors and the reflecting surfaces
- Cleaning the display
- Cleaning the exterior surfaces of the system

Cleaning the 18/36-track cartridge tape drive

A cleaning cartridge is shipped with each 18/36-track cartridge tape drive. This cartridge should be replaced after 500 uses.

When the tape drive needs to be cleaned, CLEAN appears in the message display after a cartridge is unloaded and during a rewind or locate operation.



NOTE: CLEAN is a status message, not an error message.



CAUTION: Never power off the tape drive without following the cleaning procedure once the CLEAN message appears.



CAUTION: The cleaning cartridge must be undamaged and clean.

To clean the 18/36-track cartridge tape drive read/write heads:

1. Remove any cartridge loaded in the tape drive.
2. Insert the cleaning cartridge.

The cleaning cycle takes approximately 15 seconds.

3. Remove the cleaning cartridge when it is unloaded.
4. Mark the usage on the tape label. Do not use a grease pencil.

You must clean the 18/36-track cartridge tape drive regularly to keep it functioning properly.

Cleaning the 26-track cartridge tape drive

The 26-track, or quarter inch cartridge (QIC) tape drive heads should be cleaned at least once a week. If you use the drive for eight hours or more per day, then you should clean the drive daily. The process is simple and requires little time.

1. If there is a cartridge in the tape, remove it.
2. Insert the cleaning cartridge in the tape drive and close the door. Cleaning begins automatically once the tape is inserted.
3. Allow the tape to run for approximately 30 seconds, then remove it.



NOTE: *Replace the foam pad on the cleaning cartridge after it has been used three times. The cleaning cartridge itself can be used 100 times.*

Cleaning the DVD drive

Follow the DVD cleaning directions and recommended cleaning frequency.

1. If there is a DVD disk in the drive, remove it.
2. Follow the directions to clean the DVD drive.

Cleaning the diskette drive

The floppy disk drive must be cleaned at recommended intervals to prevent read and write disk errors.

To clean the diskette drive:

1. If there is a diskette in the floppy disk drive, remove it.
2. Insert the cleaning diskette into the disk drive.
3. Follow the directions on the cleaning diskette to clean the diskette drive.
4. Remove the cleaning diskette.

Cleaning the sensors and the reflecting surfaces



CAUTION: *Never use abrasive materials or strong solvents when cleaning sensors.*

The following is a list of sensors to clean:

- Q850 and Q861 sensor
- Q1011/1009 sensor and mirror
- High Capacity Feeder/Stacker configuration
 - Q1106 sensor
 - Q1166 sensor
 - Q1107 sensor
 - Q1164 sensor
- Production publisher configuration (finisher sensors)
 - Q1201 sensor
 - Q1202 and Q1203 sensors
 - Q1205, Q1206, and Q1207 sensors
 - Q1213 sensor
 - Q1221, Q1218, and Q1227 sensors
 - Q1222 and Q1210 sensors

Cleaning the Q850 and Q861 sensor

1. Open the right and left doors of the printer and locate Area 4.
2. Raise the Area 4 green handle until it locks into place.

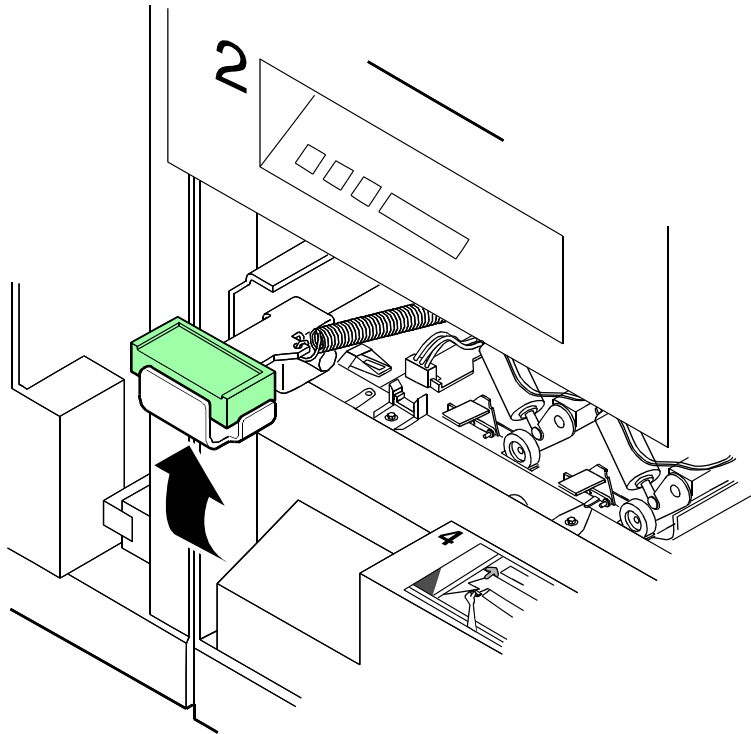

Figure 3-30 Area 4 and green handle

3. Locate the Q850 and Q861 sensor.

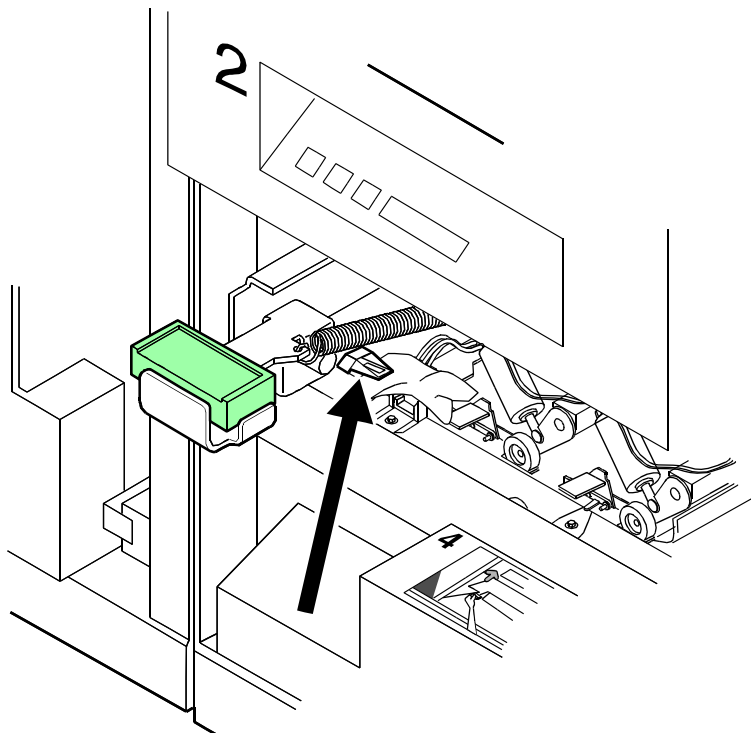

Figure 3-31 Q850 and Q861 sensor

4. Place a dry cleaning pad on the sensor and move it from left to right to clean the sensor.
5. Lower the Area 4 green handle.
6. Close the printer doors.

Cleaning the Q1011/1009 sensor and mirror

1. Open the right and left doors of the printer and locate the Q1011/1009 sensor.

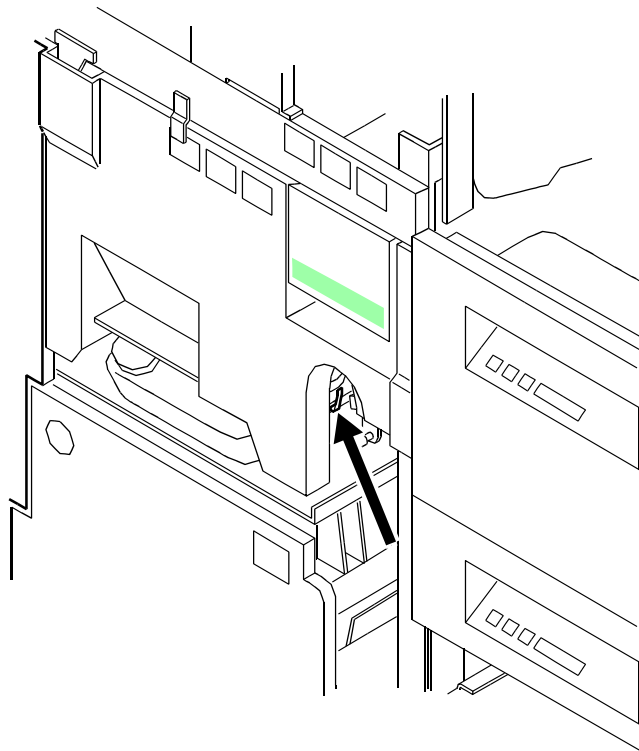

Figure 3-32 Q1011/1009 sensor and mirror

2. Apply a small amount of lens and mirror cleaner to a cleaning pad.
3. Wipe the sensor gently with the cleaning pad.

Cleaning the Q1106 and Q1166 sensors



NOTE: *High volume printer configuration only*

To access sensors Q1106 and Q1166, open the top cover of the high capacity stacker.

To clean the sensors:

1. Brush or wipe the sensor windows lightly.
2. Remove any dust present in the area.

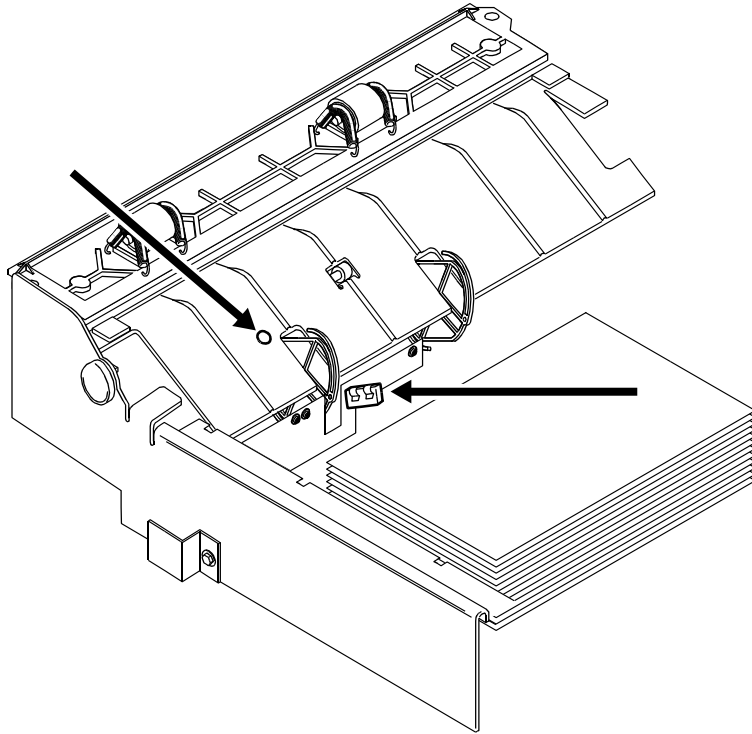

Figure 3-33 Q1106 and Q1166 sensors

Cleaning the Q1107 sensor



NOTE: *High volume printer configuration only*

To access sensor Q1107, open the top cover of the high capacity stacker.

To clean the sensor:

1. Brush or wipe the sensor windows lightly.
2. Remove any dust present in the area.

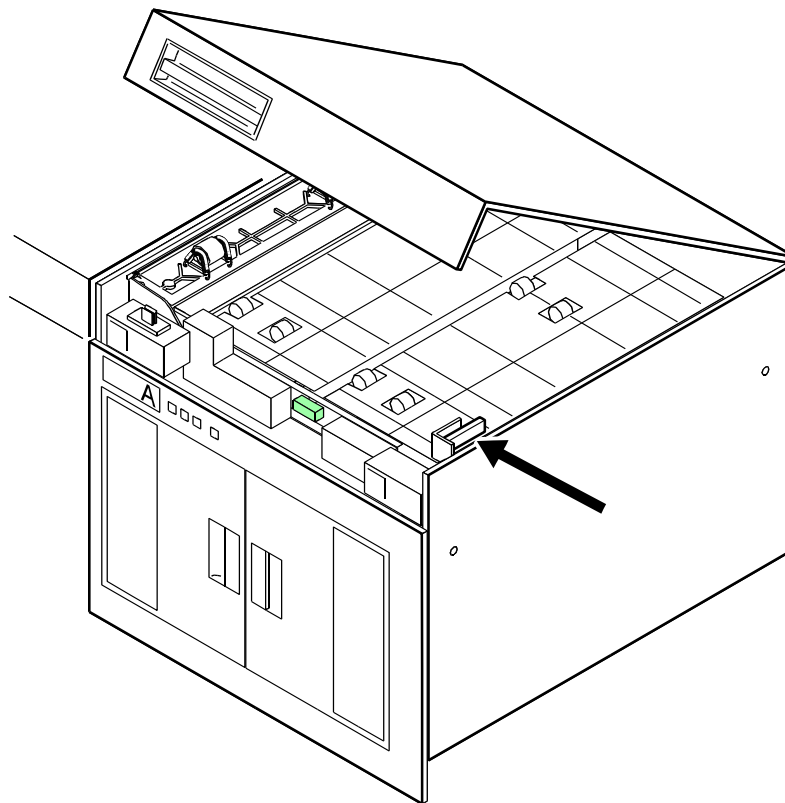

Figure 3-34 Q1107 sensor

Cleaning the Q1164 sensor



NOTE: *High volume printer configuration only*

To access sensor Q1164, open the top cover of the last feeder/stacker module, the one containing the purge tray.

To clean the sensor:

1. Brush or wipe the sensor windows lightly.
2. Remove any paper dust present in the area.

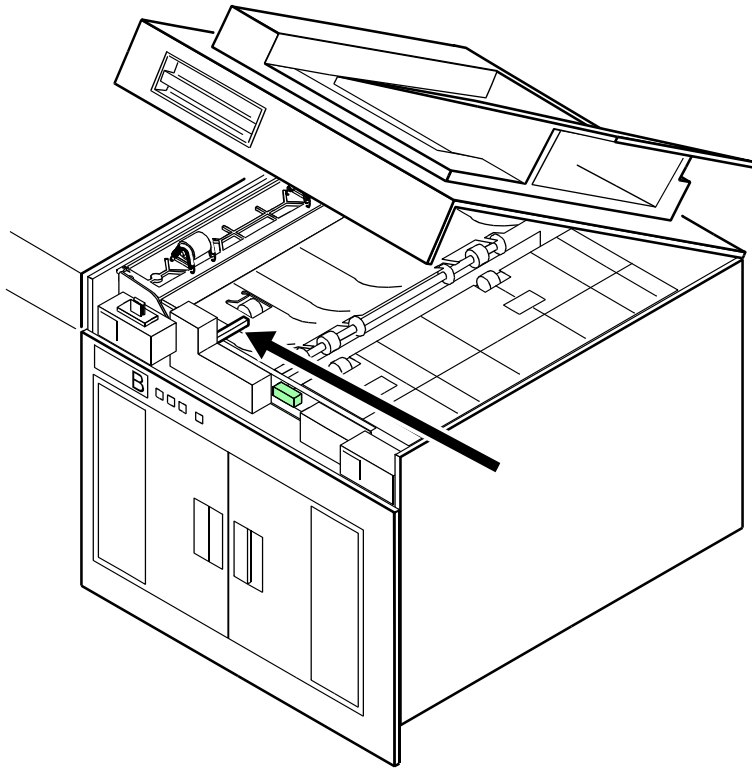

Figure 3-35 Q1164 sensor

Cleaning the display

The display should be cleaned as required.

Clean the display with a soft, lint-free cloth dampened with a glass or lens and mirror cleaner. Do not spray the liquid directly onto the display because it may cause damage.

Cleaning the exterior surfaces of the system

Clean the exterior surfaces of the printer daily, if possible.

Clean the exterior surfaces with a mild household detergent that has been poured or sprayed onto a cloth lightly dampened with water. Do NOT saturate the cloth; just dampen it.



CAUTION: *Liquids must not be allowed to drip onto anything electrical or mechanical. Also, never spray or pour any cleaner directly onto the keyboard or the exterior surfaces of the system.*

Clearing or cleaning the finisher sensors



NOTE: *Production publisher configuration only*

Clearing the finisher sensors should be performed only when directed by a Customer Support Center Representative.



NOTE: *The finisher sensors are located under the processor top cover, under the finisher top cover, and behind the finisher and bindexer doors.*

Use the following procedure to clear any obstructions from the finisher sensors.

1. Fold a sheet of 8.5 x 11 inch (216 x 279 mm) paper, as shown in figure 3-36.

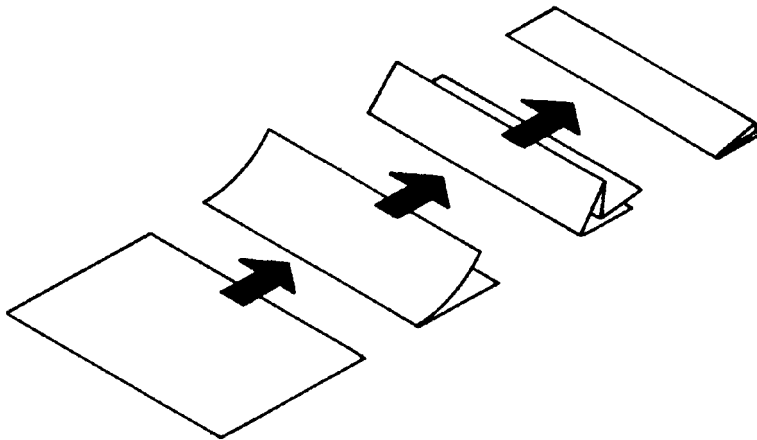

XEA037A

Figure 3-36 Folding the paper

2. Use the folded sheet of paper to clear any obstructions in the following sensor areas.

Clearing the Q1201 sensor



NOTE: *Production publisher configuration only*

Clearing the Q1201 sensor should be performed only when directed by a Customer Support Center Representative.

1. Open the processor top cover.



NOTE: *The Q1201 sensor is located under the processor top cover on the right side.*

2. Locate the Q1201 sensor, as shown in figure 3-37

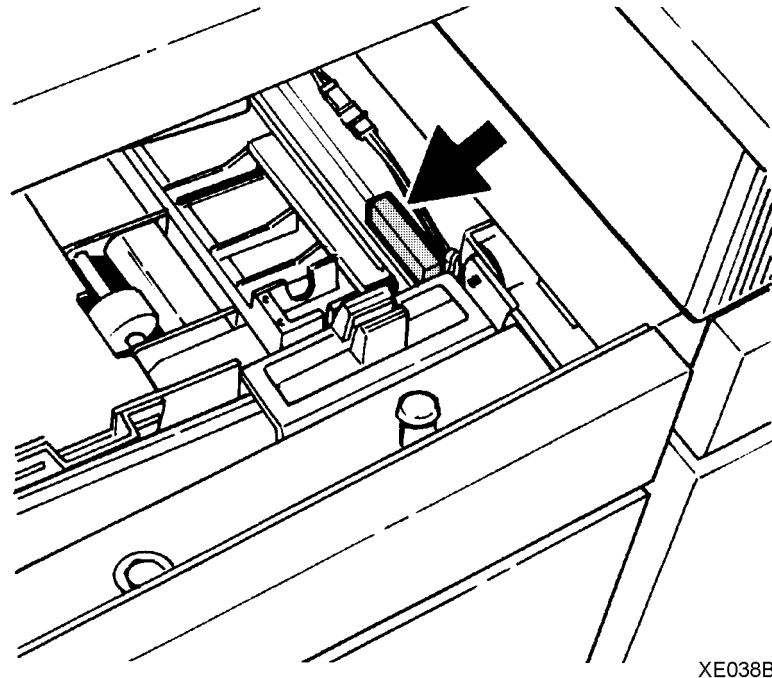

Figure 3-37 Locating the Q1201 sensor

3. Brush a folded sheet of paper under the sensor to clear any obstructions.
4. Close the processor cover.

Clearing the Q1202 and Q1203 sensors



NOTE: *Production publisher configuration only*

Clearing the Q1202 and Q1203 sensors should be performed only when directed by a Customer Support Center Representative.

1. Open the finisher top cover.
2. Locate the Q1202 and Q1203 sensors, as shown in figure 3-38.

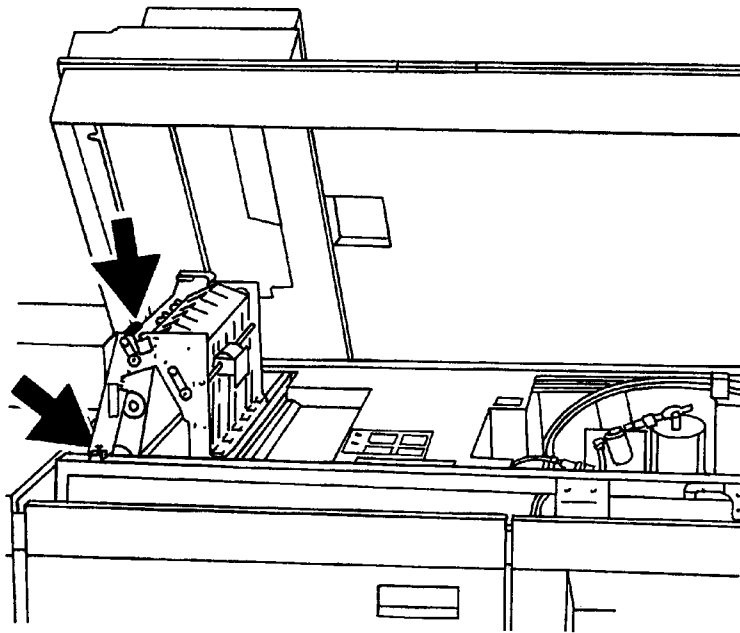

XEA098A

Figure 3-38 Locating the Q1202 and Q1203 sensors

3. Brush a folded sheet of paper under each sensor to clear any obstructions, as shown in figure 3-39.

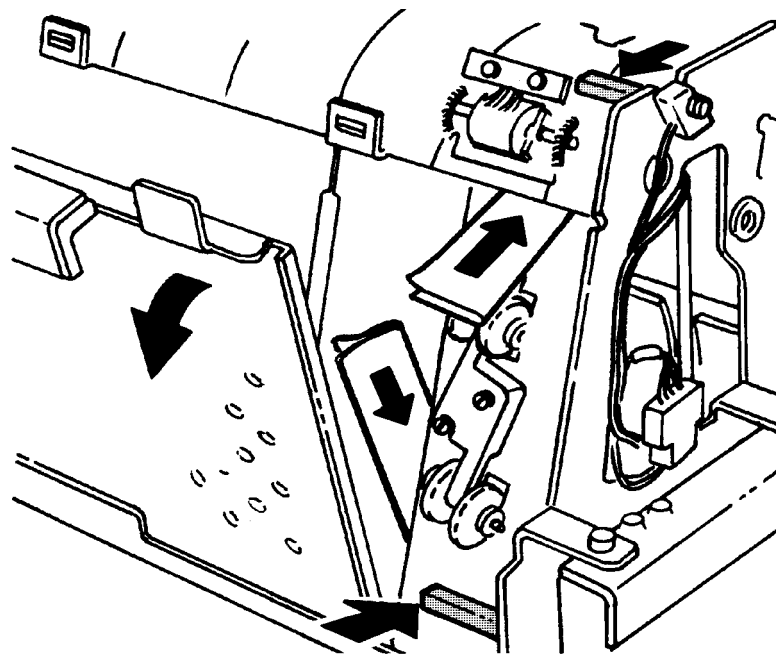

XE039B

Figure 3-39 Clearing the Q1202 and Q1203 sensors

4. Close the finisher top cover.

Cleaning the Q1222 and Q1210 sensors



NOTE: *Production publisher configuration only*

Cleaning the Q1222 and the Q1210 sensors should be performed only when directed by a Customer Support Center Representative.

1. Open the finisher top cover.
2. Look down at the rear section of the tilt bed area, as shown in figure 3-40, to view the sensors.

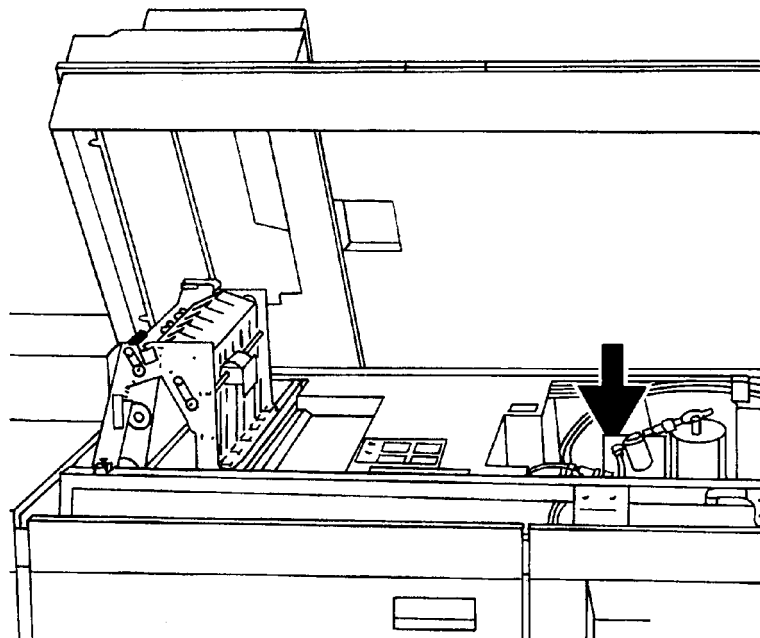

XEA099A

Figure 3-40 Locating the Q1222 and Q1210 sensors

3. Locate the Q1222 and Q1210 sensors, as shown in figure 3-41

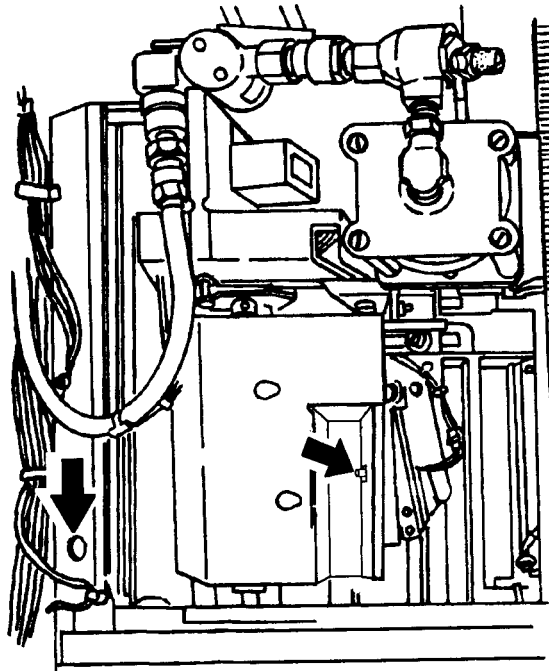

XE041C

Figure 3-41 Locating the Q1222 and Q1210 sensors

4. Wipe each sensor gently with a soft cloth to clean them.
5. Close the finisher top cover.

Clearing the Q1205, Q1206, and Q1207 sensors



NOTE: *Production publisher configuration only*

Clearing the Q1205, Q1206, and Q1207 sensors should be performed only when directed by a Customer Support Center Representative.

1. Open the finisher front doors.
2. Open the bindexer door.
3. Locate the Q1205, Q1206, and Q1207 sensors, as shown in figure 3-42.

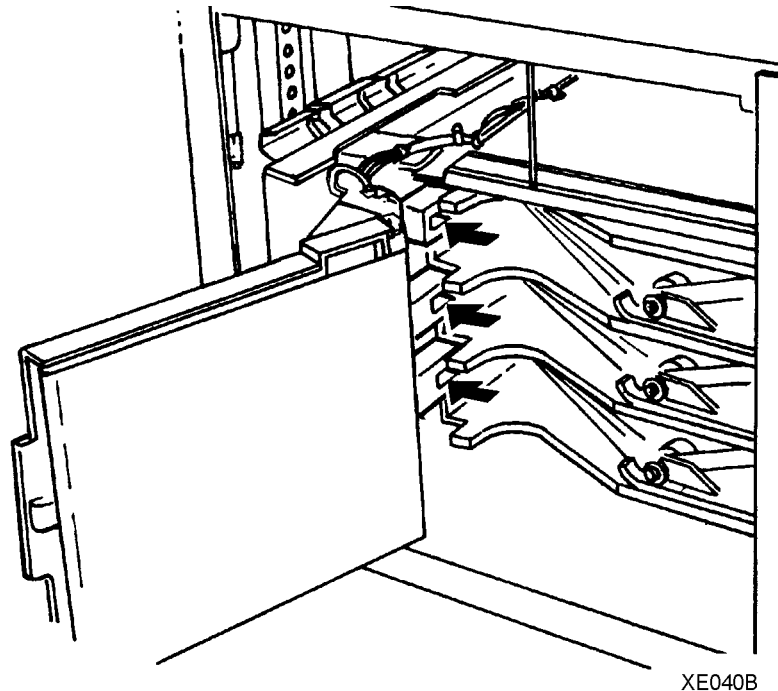

Figure 3-42 Locating the Q1205, Q1206, and Q1207 sensors

4. Brush a folded sheet of paper across each sensor to clear any obstruction.
5. Close the bindexer and finisher doors.

Clearing the Q1213 sensor



NOTE: *Production publisher configuration only*

Clearing the Q1213 sensor should be performed only when directed by a Customer Support Center Representative.

1. Open the finisher doors.



WARNING: *The top of the binder is approximately 425°F (218°C). Do not touch the heated areas or you may get burned. If the binder has been in a "Ready" condition, allow it to cool for at least 1 hour before continuing the procedure.*

2. Grasp the green handle on the binder drawer. Pull the drawer out until it stops.
3. Locate the Q1213 sensors, as shown in figure 3-43

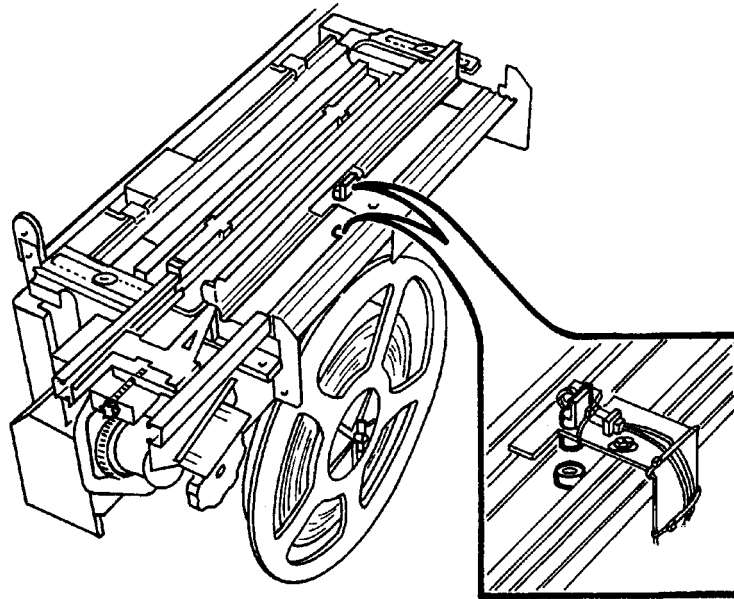

XEA101A

Figure 3-43 Q1213 sensor

4. Brush a folded sheet of paper across the sensor to clear any obstruction.
5. Close the binder drawer and the finisher doors.

Clearing the Q1221, Q1218, and Q1227 sensors



NOTE: *Production publisher configuration only*

Clearing the Q1221, Q1218, and Q1227 sensors should be performed only when directed by a Customer Support Center Representative.

1. Open the finisher front doors.
2. Locate the Q1221, Q1218, and Q1227 sensors, as shown in figure 3-44.

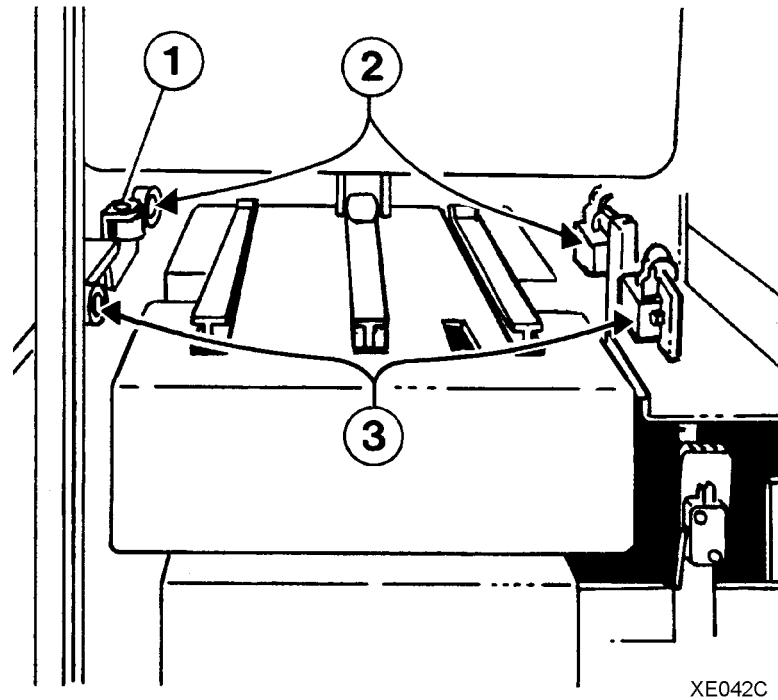

Figure 3-44 Locating the Q1221, Q1218, and Q1227 sensors

Cleaning the binder



NOTE: *Production publisher configuration only*

Keep the binder clean to prevent binder tape jams. Clean the binder once a week, or as needed, and also when changing the binder tape.

It is highly recommended that the binder be cleaned before the binder warm-up cycle begins or before switching the system on. The following steps must be performed to clean the binder.



WARNING: *All areas of the binder drawer, including the binder tape, are hot, approximately 425°F (218°C), and may cause a serious burn. If the binder has been in a "Ready" condition, allow the binder to cool for at least one hour before continuing the procedure.*

1. Open the finisher doors.



WARNING: *A sharp edge on the plastic binder platen cleaner or on the tape spool sometimes occurs as a result of removing the cleaner. This sharp edge could cause finger cuts.*



CAUTION: *To avoid damage to the system, do not use any liquids or any abrasive material to clean the binder. Use the plastic binder platen cleaner on the tape reel or use a clean, lint-free cloth.*

2. Grasp the green handle on the binder drawer. Pull the drawer out until it stops.

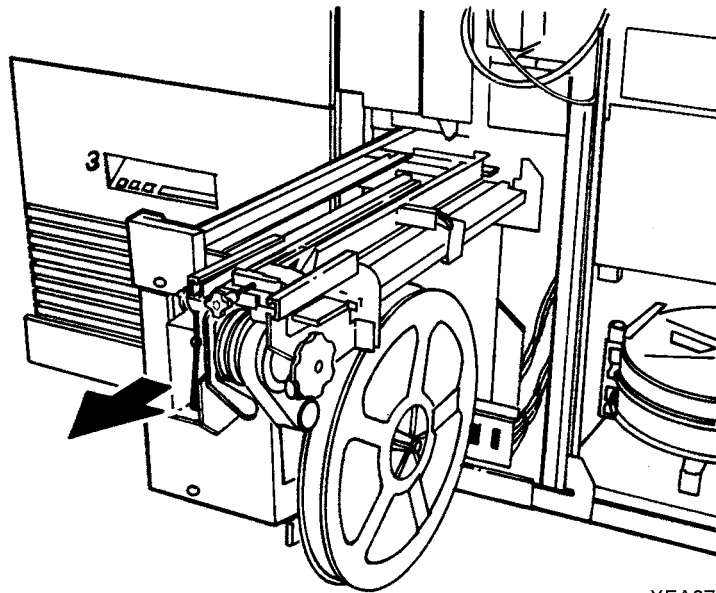

XEA070A

Figure 3-45 Opening the binder drawer

3. Perform the following steps:
 - a. Locate and remove the plastic binder platen cleaner from the binder tape reel, as shown in the following figure.

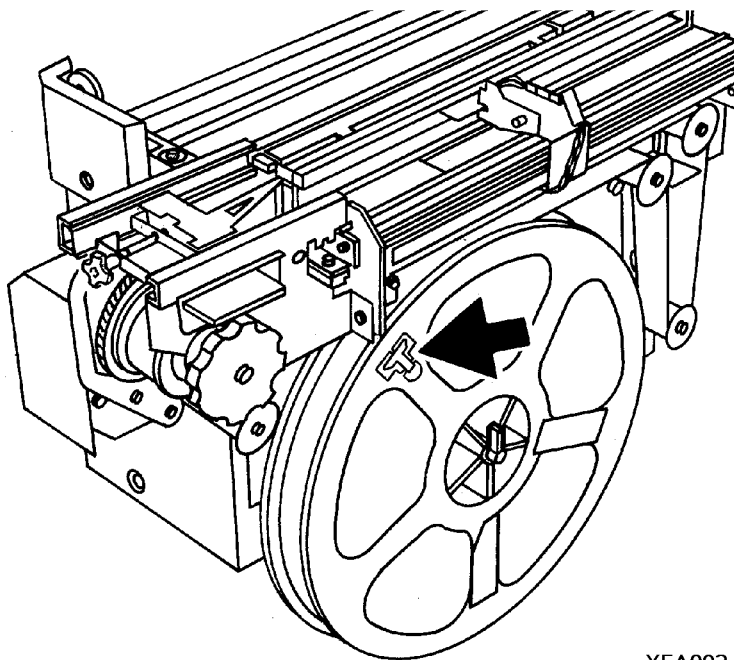

XEA092

Figure 3-46 Binder platen cleaner

- b. If binder tape is in the area of the cleaner, pull the reel slightly away from the tape to avoid tape damage.
 - c. Lift up on the cleaner and push down against the single end tab. Move the cleaner back and forth until the end tab breaks.

- d. Continue to move the cleaner in the same manner until the 2-sided tabs break.



NOTE: *Ensure that the following cleaning procedures are performed in the order listed.*

Cleaning the binder tape guides



NOTE: *Production publisher configuration only*

The following steps must be performed to clean the binder tape guides.

1. Use the binder platen cleaner to clean the surfaces and grooves of the tape guides.
2. Ensure that all the glue is removed from the grooves on the tape guides.

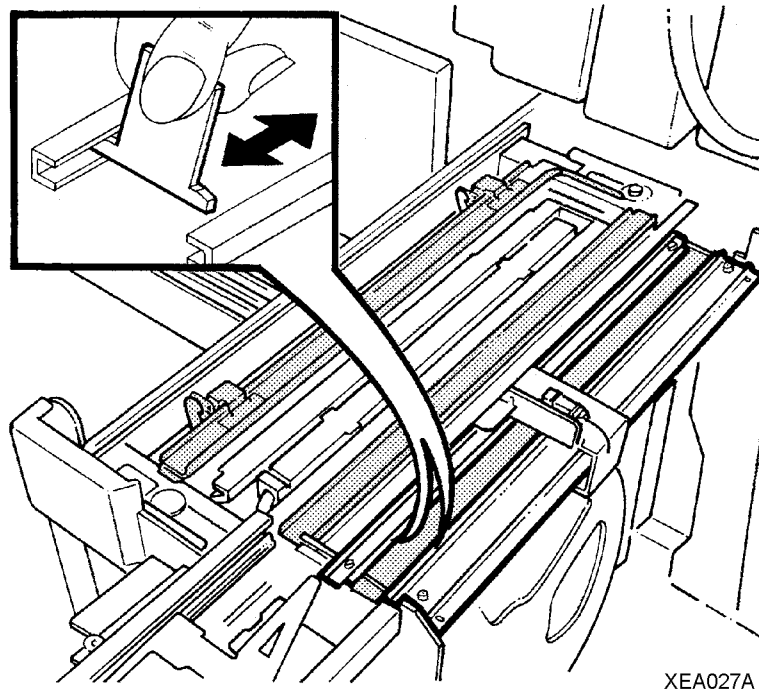

Figure 3-47 Cleaning the tape guides

Cleaning the binder platen



NOTE: *Production publisher configuration only*

The following steps must be performed to clean the binder platen.

1. Use the binder platen cleaner to clean the top and side surfaces of the binder platen until all the glue is removed.

2. Ensure that the glue is removed from the grooves on the binder platen surface, which align with the top and bottom edges of the book.

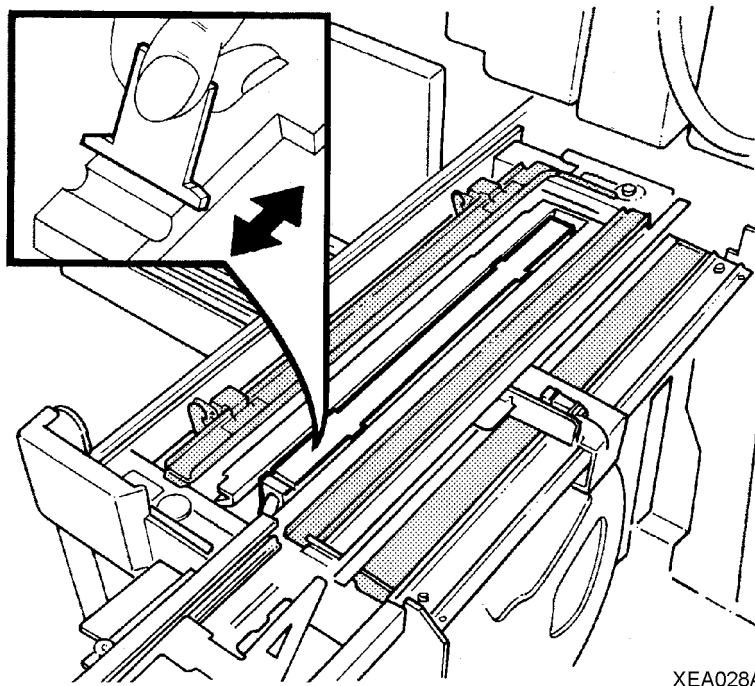

Figure 3-48 Cleaning the binder platen

Cleaning the flappers



NOTE: *Production publisher configuration only*

Using the binder platen cleaner, clean the top and side surfaces of the binder flappers until all the glue is removed.

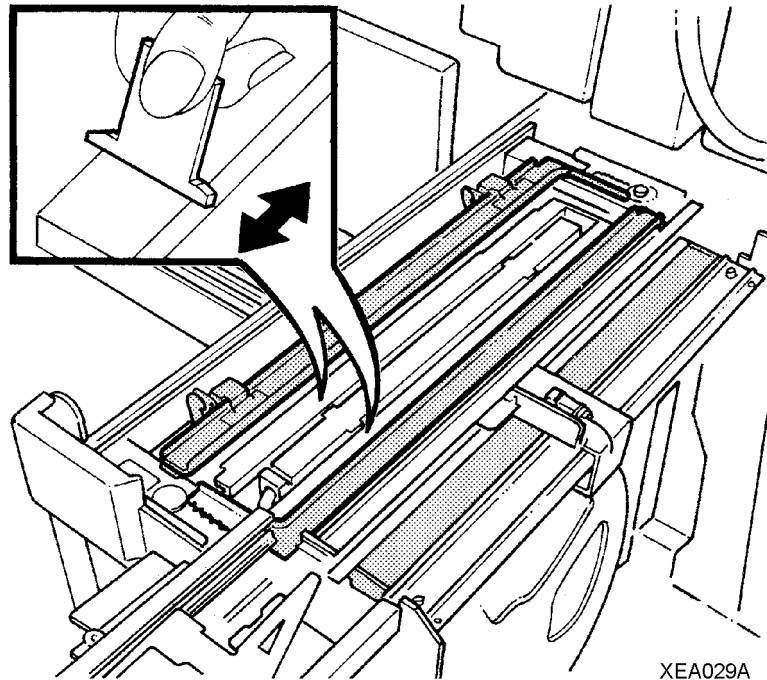

Figure 3-49 Cleaning the flappers

Cleaning the calipers



NOTE: *Production publisher configuration only*

Using the binder platen cleaner, clean the binder caliper surfaces until all the glue is removed.

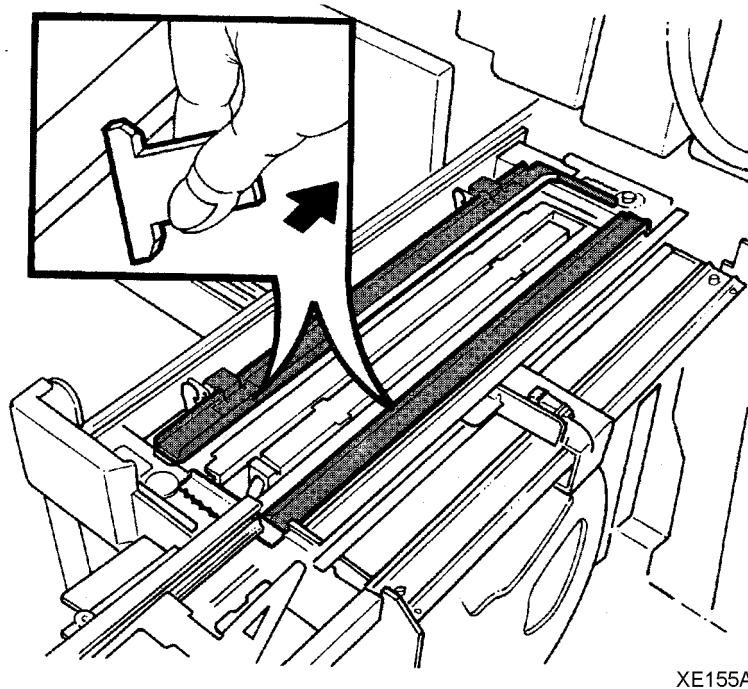

Figure 3-50 Cleaning the calipers

Closing the binder



NOTE: *Production publisher configuration only*

Perform the following steps to close the binder.

1. Push in the binder drawer until it stops.
2. Close the finisher doors.
3. Place the platen cleaner in a safe place.

Replacing the stitcher spool A



NOTE: *Production publisher configuration only*

Use this procedure to replace stitcher spool A in the system. Check stitcher spools A and B visually during the warm-up cycle. Stitcher spool A is the spool on top, and stitcher spool B is the spool on the bottom.

If spool B needs new wire, call the customer support center.

There is a label behind the stitcher panel that gives instructions for replacing the stitcher spool A. Refer to this label if needed.

The following steps must be performed to replace the stitcher spool A.

1. Open the finisher doors.
2. Lift the stitcher panel, which is located directly above the stitcher spools.
3. Pull the green stitcher head release handle forward and up until it latches into place, as shown in figure 3-51.

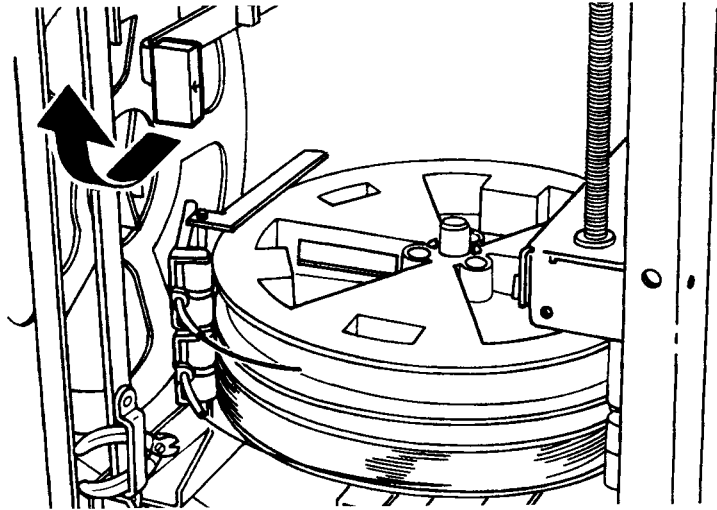

XE059D

Figure 3-51 Releasing the stitcher head

4. Remove the stitcher wire plug.
 - a. The stitcher wire plug is located above the binder area, as shown in figure 3-52.
 - b. Press and hold down the release clip.
 - c. Pull the plug out of the stitcher head.

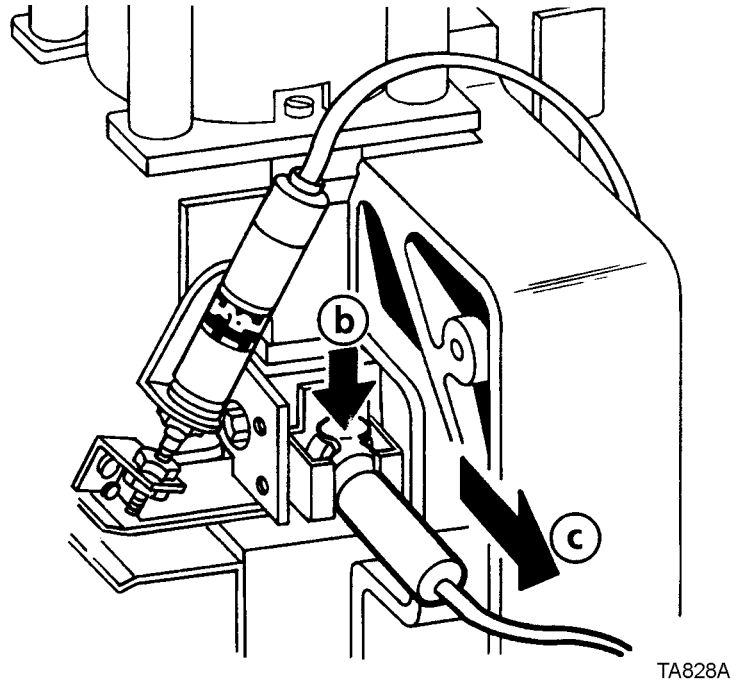

Figure 3-52 Removing the stitcher wire plug

5. Perform one of the following steps:

- If there is no wire on the spool, use the wire cutters to pull the remaining wire carefully out of the tubing, as shown in figure 3-53.



NOTE: The wire cutter tool needed to perform this procedure is located next to stitcher spool B.

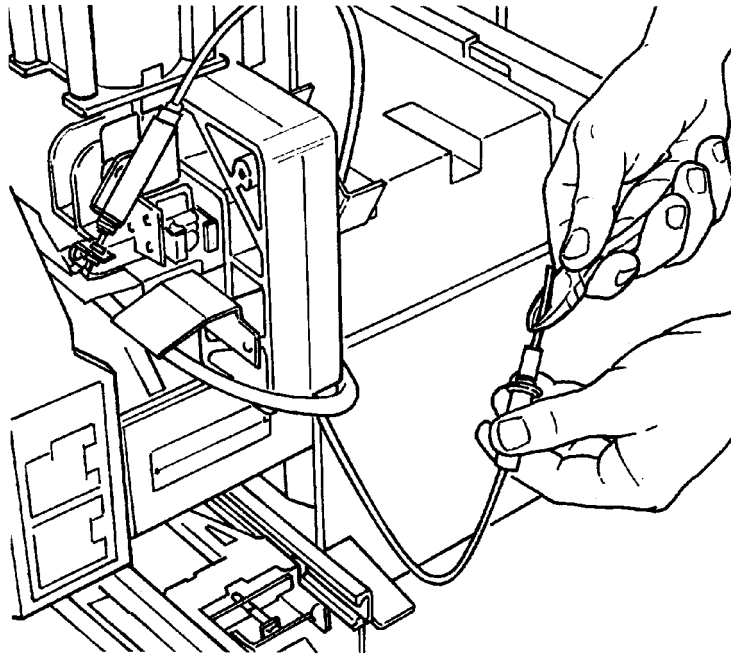

XEA084A

Figure 3-53 Removing the wire from the tubing

- If there is wire on the spool, hold it on the spool and carefully rewind the remaining wire out of the tubing and onto the stitcher spool, as shown in figure 3-54.

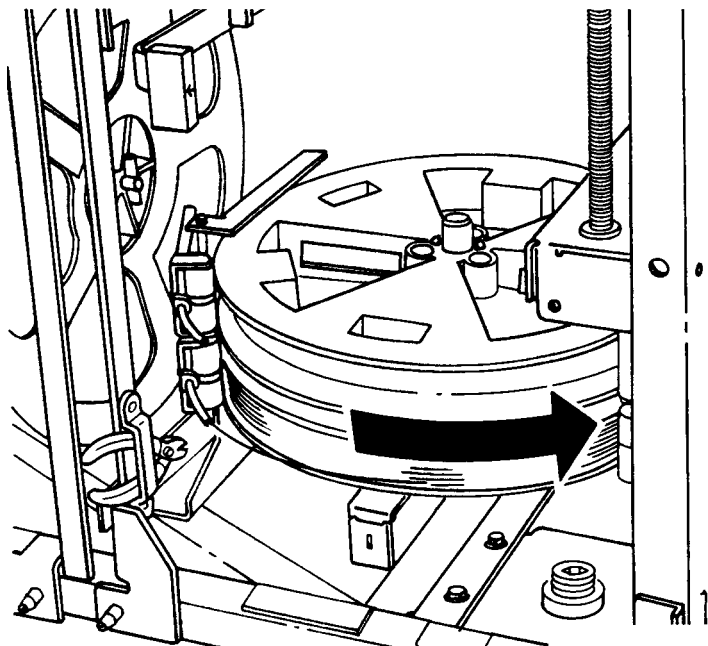

XEA061A

Figure 3-54 Rewinding the remaining wire

6. Insert the plug into the measuring bracket, as shown in figure 3-55.

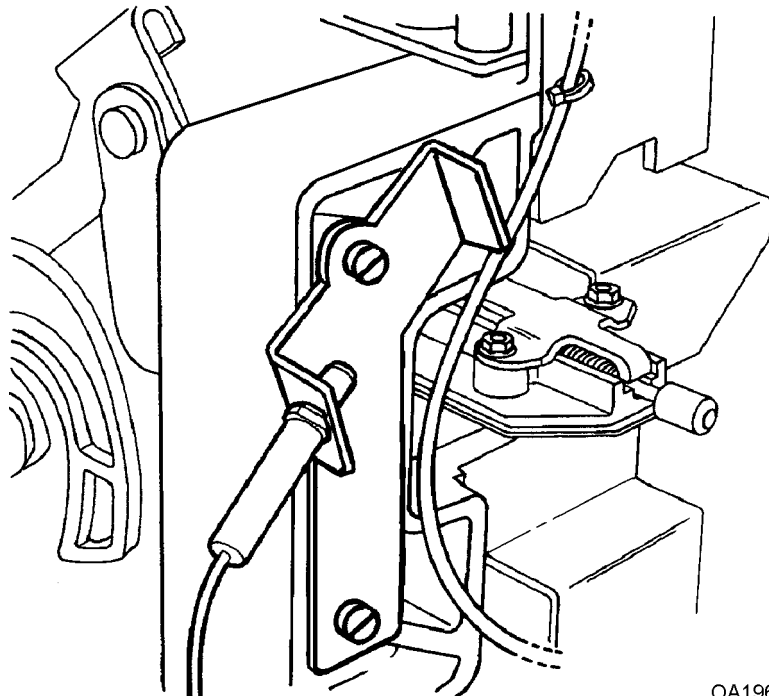

OA196A

Figure 3-55 The measuring bracket

7. Release and remove stitcher spool A.
 - a. Locate the green pin release handle under spool B, as shown in figure 3-56.

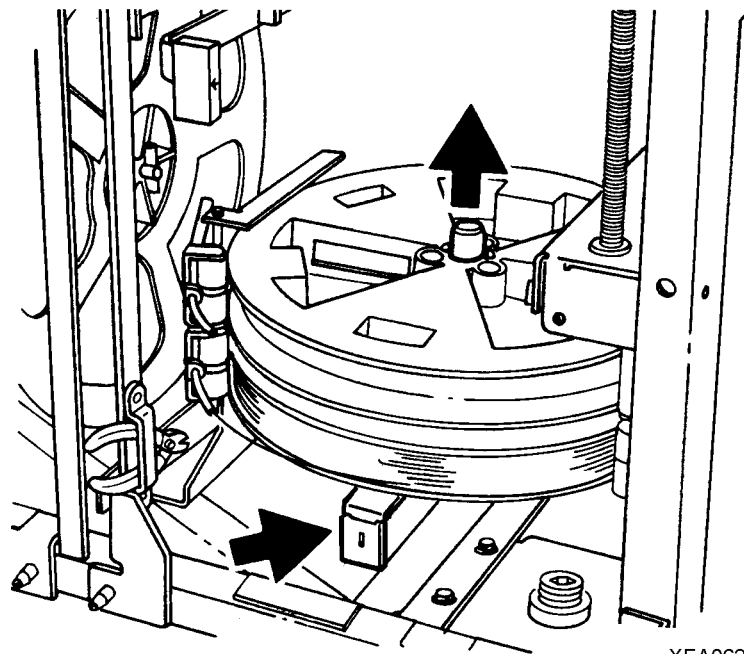

XEA062A

Figure 3-56 Removing the stitcher spool pin

- b. Pull and hold the handle forward and remove the pin.
- c. Release the handle and remove stitcher spool A.

8. Install the new stitcher spool.
 - a. Slide the new stitcher spool into position with the paper wrapper still in place.
 - b. Replace the stitcher spool pin. Push it down until it locks into place, as shown in figure 3-57.

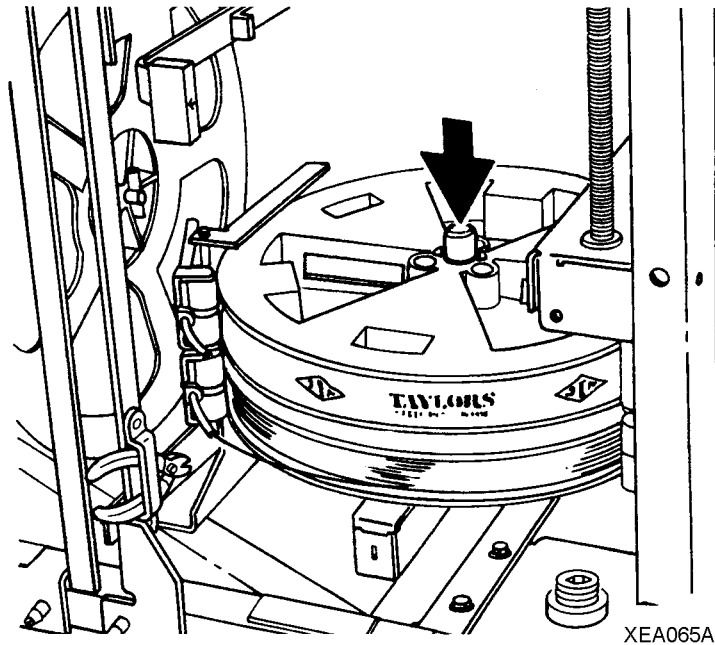

Figure 3-57 Replacing the pin

9. Remove any damaged wire.



WARNING: *Hold the wire on the spool to prevent eye injury and to keep the wire from unwinding.*

- a. Locate the end of the wire on the new spool.
- b. Using the wire cutters, carefully clip any bent or twisted wire from the lead end of the wire.
- c. Hold onto the end of the wire and carefully remove the paper wrapper, as shown in figure 3-58.

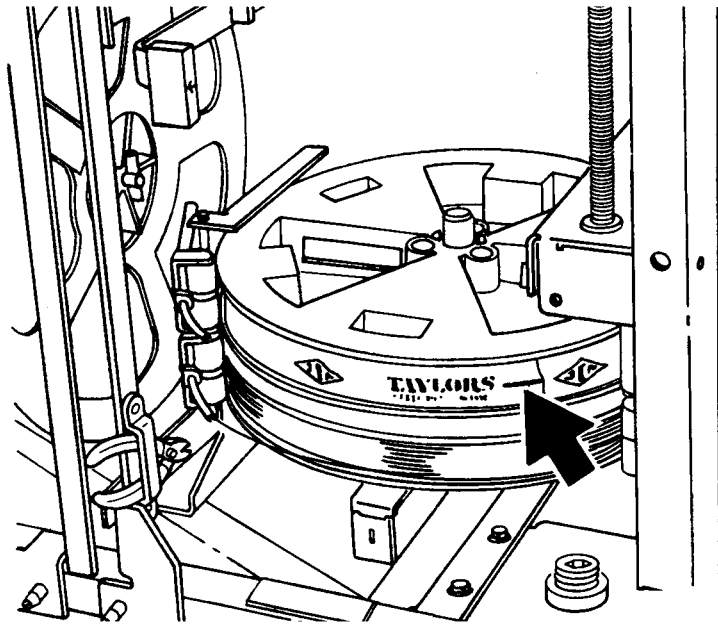

XEA066A

Figure 3-58 Removing the paper wrapper



NOTE: Hold the wire between the thumb and forefinger of both hands.

10. Feed the wire slowly into the tubing until the wire extends from the stitcher plug, as shown in figure 3-59.

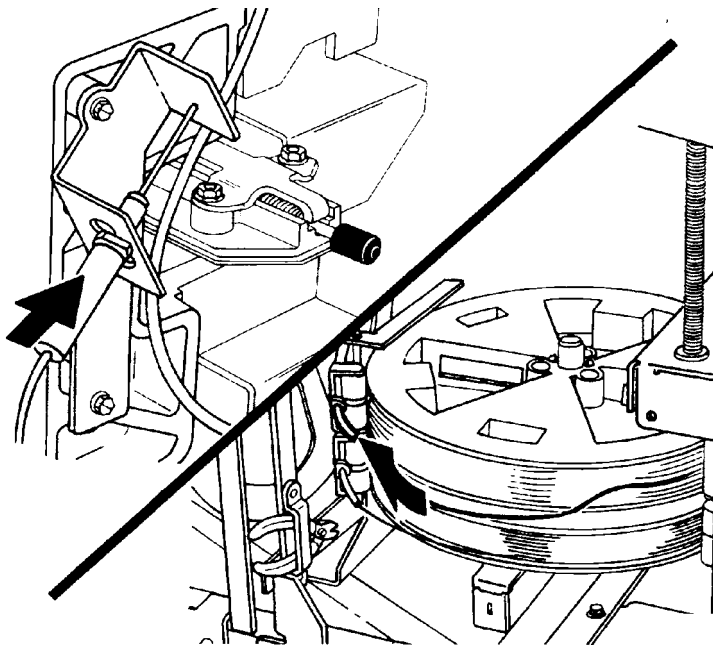

XE154A

Figure 3-59 Feeding the wire

11. Remove the stitcher plug from the measuring bracket.

12. Slowly and carefully pull about 3 feet (1 meter) of wire from the spool.
13. Cut the wire, leaving about 2 inches (51mm) of wire extending from the end of the stitcher plug.
14. Insert the plug into the measuring bracket.
15. Continue to feed the wire until it touches the back plate of the measuring bracket.
16. Push the green stitcher head release handle down and back.
17. Pull the plug from the measuring bracket.
18. Insert the plug into the stitcher head until the plug snaps into place.
19. Place the wire cutters in the storage bracket.



NOTE: *Ensure that the wire cutters are not touching the stitcher spools. This can prevent the stitcher wire from feeding properly.*

20. Lower the stitcher panel.



NOTE: *Ensure that the stitcher panel has been lowered. The stacker will not deliver prints if the stitcher panel is left in the up position.*

21. Close the finisher doors.

Storing the binder tape reels



NOTE: *Production publisher configuration only*

Binder tape contains paper that makes the tape sensitive to the same conditions that affect paper, especially moisture. Figure 3-60 shows good storage conditions for the binder tape.

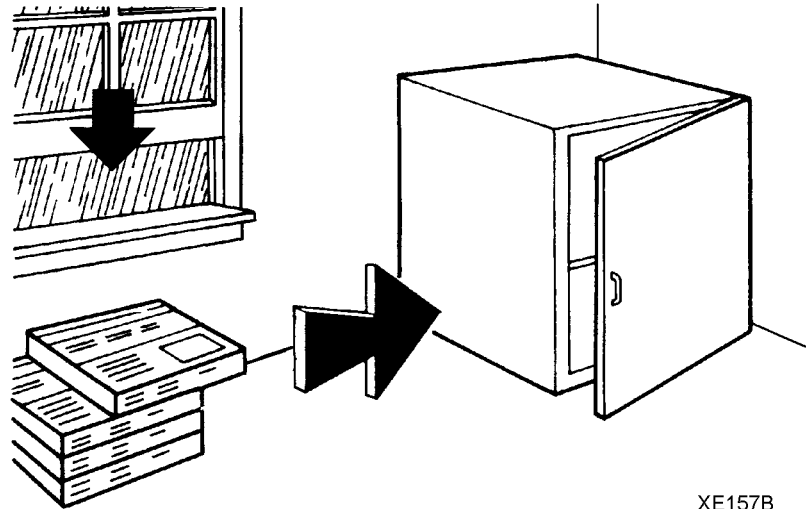

XE157B

Figure 3-60 Storing binder tape in a cool, dry place

Perform the following steps to store the binder tape wheels.

1. Always store binder tape in a dry place cooler than 90°F (32°C).
2. Keep stored rolls in their original unopened containers.
3. Use rolls with older dates first. Save the original foil containers for reuse in storing partially used rolls.
4. Place partially used rolls of binder tape in their original resealable foil containers. Ensure that the edge is sealed tightly.

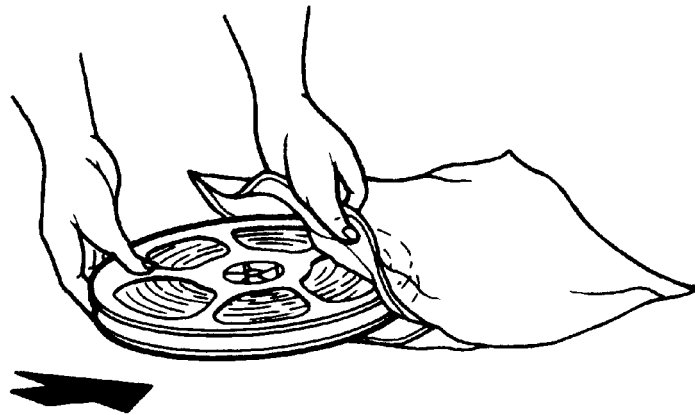

XE158A

Figure 3-61 Storing the binder tape

5. Store the partially used rolls of binder tape in a dry place cooler than 90°F (32°C).

Replacing the binder tape reel



NOTE: *Production publisher configuration only*

Use this procedure to replace the binder tape in the system.

To ensure proper binding and to reduce binder tape jams, do not leave binder tape in the system when the binder is not in use.

If necessary, refer to the label on the binder for instructions on how to replace the binder tape.

The following steps must be performed to replace the binder tape wheel.



WARNING: *All areas of the binder drawer, including the binder tape, are hot, approximately 425°F (218°C), and may cause serious burns. If the binder has been in a "Ready" condition, allow the binder drawer to cool at least one hour before continuing the procedure.*

1. Open the finisher doors.
2. Grasp the green handle on the binder drawer and pull the drawer out until it stops.

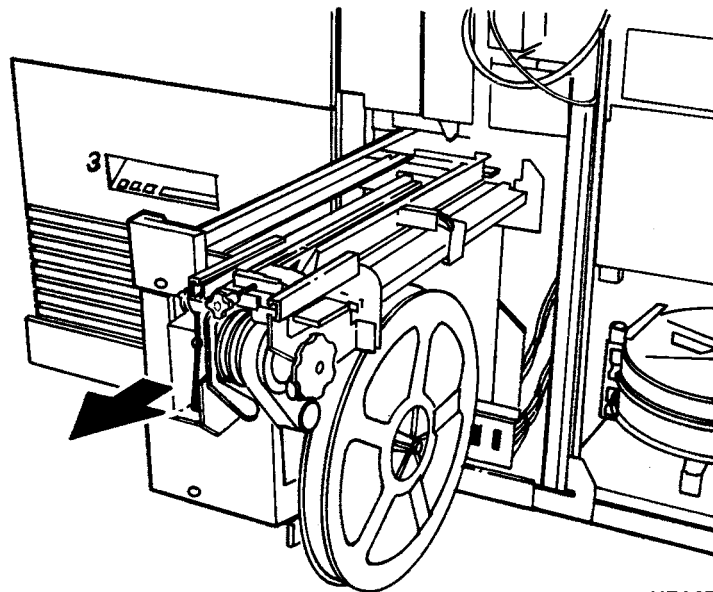

XEA070A

Figure 3-62 Opening the binder drawer

3. Remove the tape from the drive roll.
 - a. Lift the pressure roll release handle and remove the tape from the drive roll.

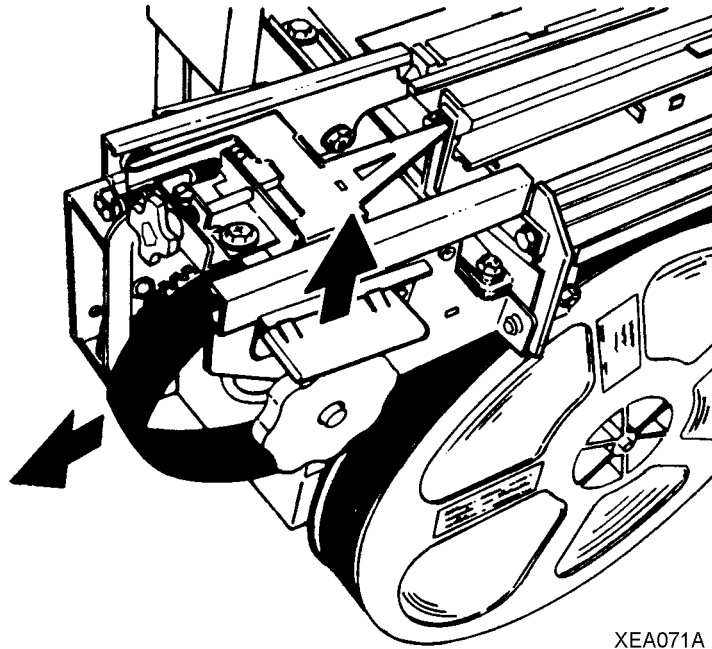

Figure 3-63 Removing the tape

- b. Rewind the tape onto the tape reel.
4. Slide the tape reel off the tape reel drive.
 - a. Move the reel retainer in the center of the reel to the horizontal unlocked position.

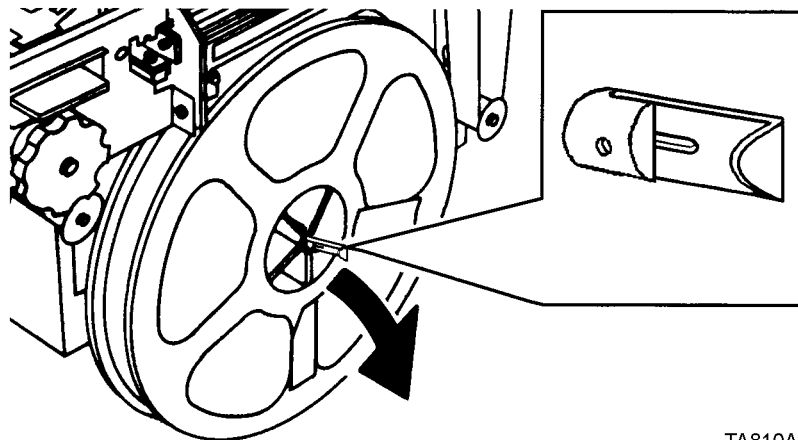

Figure 3-64 Unlocking the reel

- b. Remove the tape reel.



NOTE: Ensure that the larger center hole in the reel faces the drive.

5. Slide the new tape reel onto the tape reel drive.
 - a. If necessary, rotate the tape reel slightly until it clicks into position.



NOTE: The tape will not feed properly if the retainer is not locked.

- b. Move the reel retainer to the locked position.

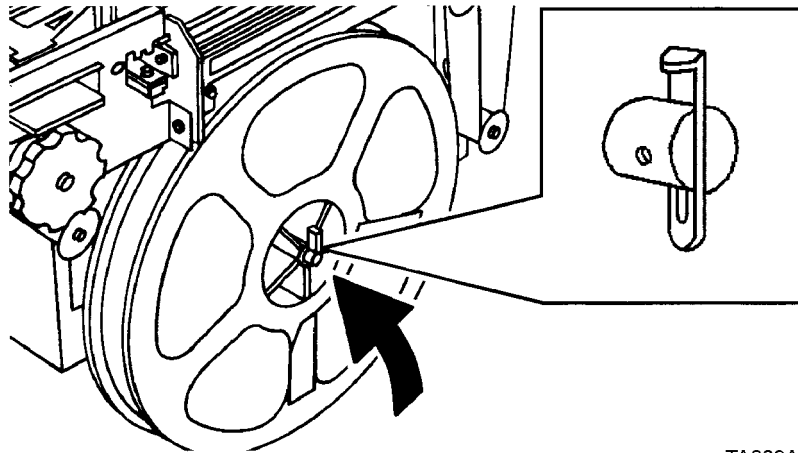

TA809A

Figure 3-65 Locking the reel



NOTE: Ensure that the tape passes through the binder tape sensor.

6. Follow the instructions on the binder tape loading label and thread the tape through the tape feeder.

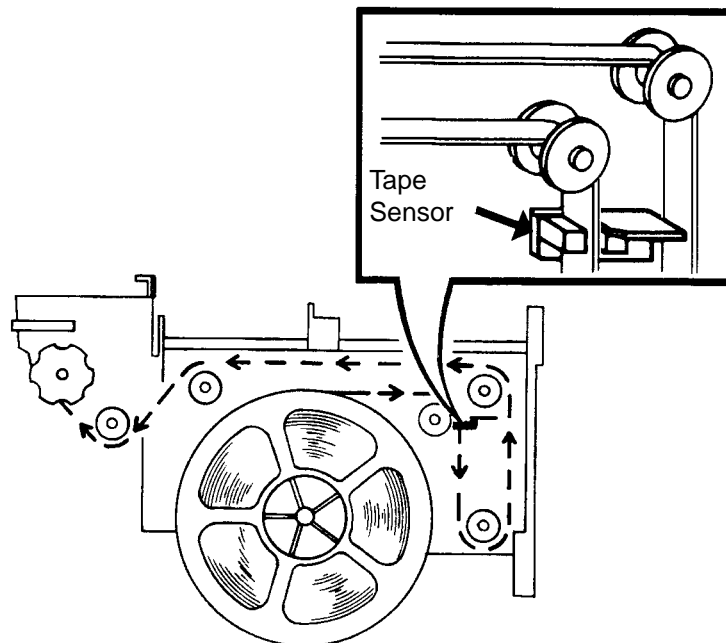

TA615C

Figure 3-66 Threading the tape through the tape feeder

7. Thread the tape around the drive roll to the edge of the pressure roll.

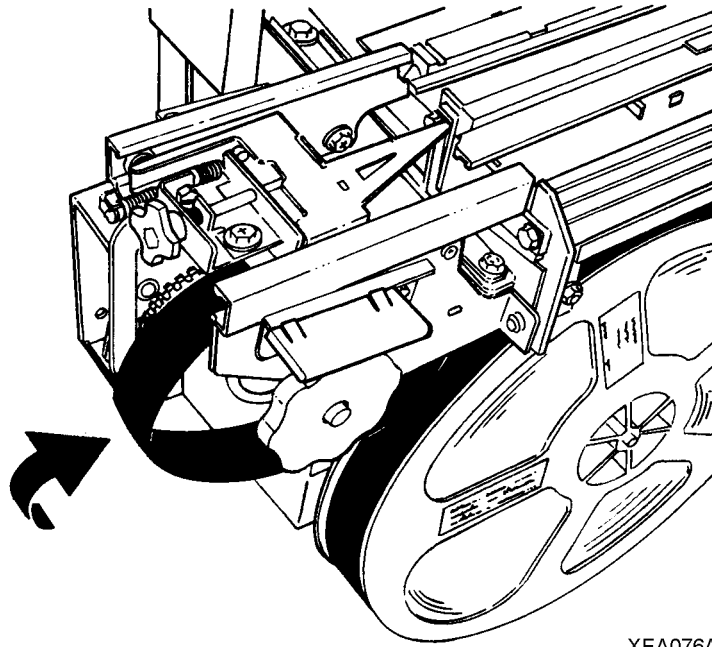

XEA076A

Figure 3-67 Threading the tape to the pressure roll

8. Turn the green knob clockwise until the tape extends at least 2 inches (51mm) beyond the tape guides.

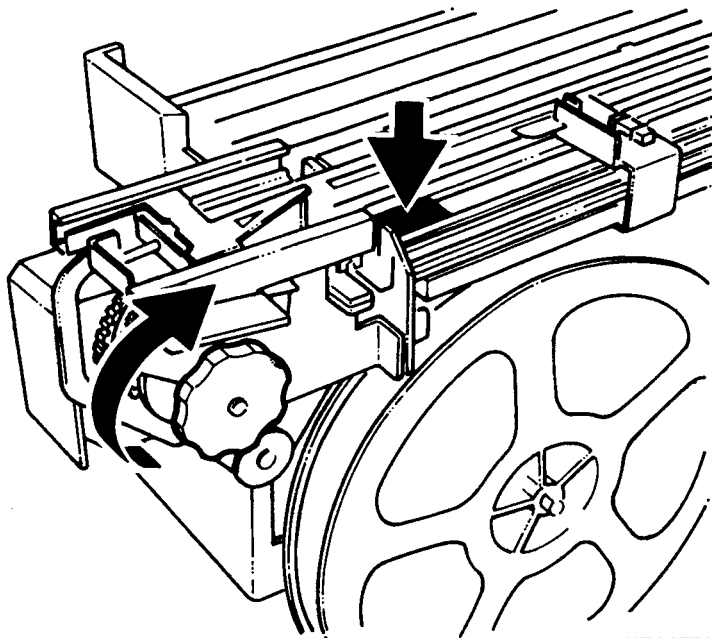

XEA077A

Figure 3-68 Feeding the tape manually

9. Cut the tape.
 - a. Lift up on the green tape cutter handle, as shown in figure 3-69.

- b. Remove the cut piece of tape.

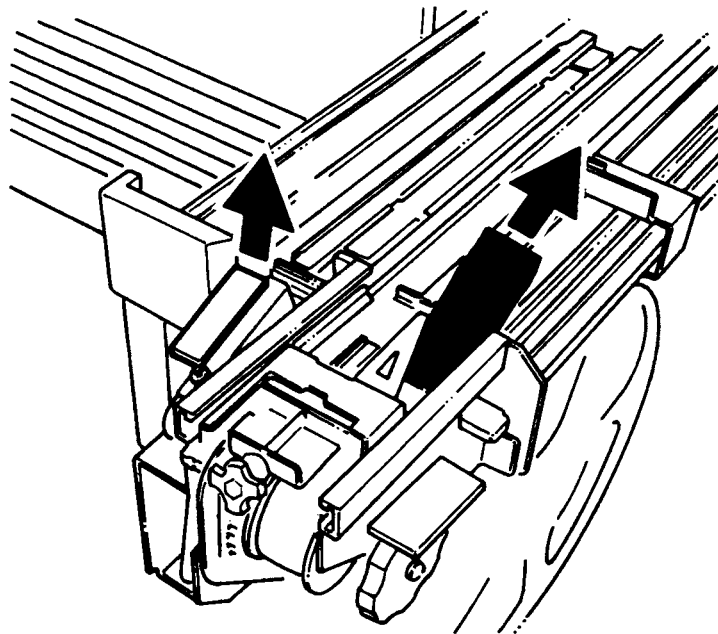

XEA078A

Figure 3-69 Cutting the tape

10. Close the binder drawer.
11. Close the finisher doors.

Adjusting the binder tape registration



NOTE: *Production publisher configuration only*

The binder tape knob is used to align the registration of the binder tape to the top edge of a bound book.

This procedure has no effect on the length of the tape, but you should perform this procedure before adjusting the tape length.

To adjust the length, refer to the on-line help.

Perform the following steps to adjust the binder tape registration.

1. Ensure that the tape guides are clean and free of glue residue.
Refer to the procedure, "Cleaning the binder," in this section.
2. Determine the adjustment amount for the top edge of the book.
3. Open the finisher doors.
4. Measure the distance between the top of the binder tape and the top of the book.
5. Locate the black binder tape knob on the front of the binder drawer.

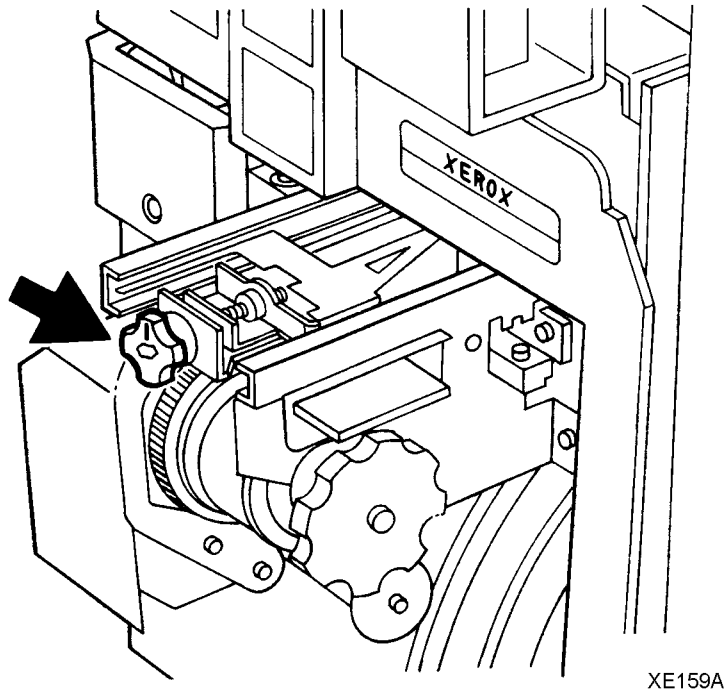
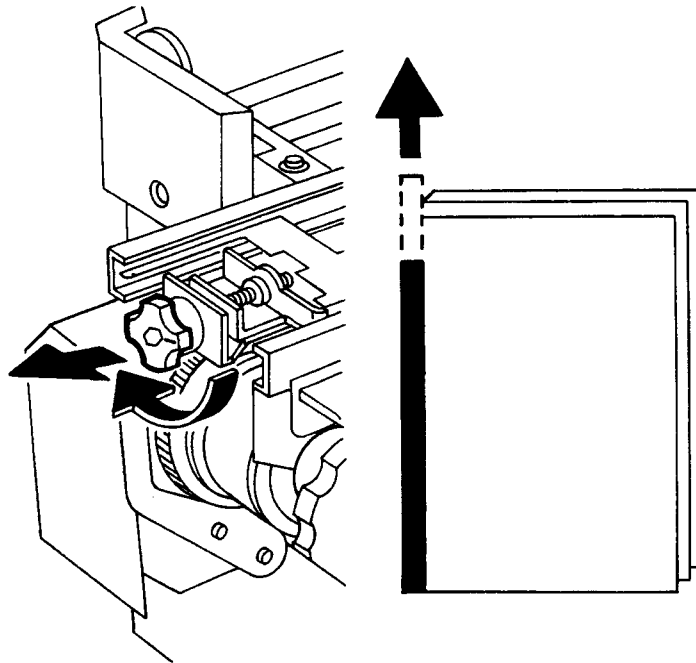

Figure 3-70 Locating the binder tape knob

The knob is spring loaded and moves in increments to change the location of the binder tape. Each increment equals a change of 0.1mm, up or down, on the edge of the book. One full rotation of the knob is equal to 0.04 inch (1mm).

6. Pull the knob toward you to rotate it for the adjustment.
7. Adjust the tape position by performing one of the following steps:
 - Pull the knob and rotate it clockwise to move the tape toward the top edge of the book, as shown in figure 3-71.



XE160A

Figure 3-71 Adjusting the tape position up

- Pull the knob and rotate it counterclockwise to move the tape toward the bottom edge of the book.

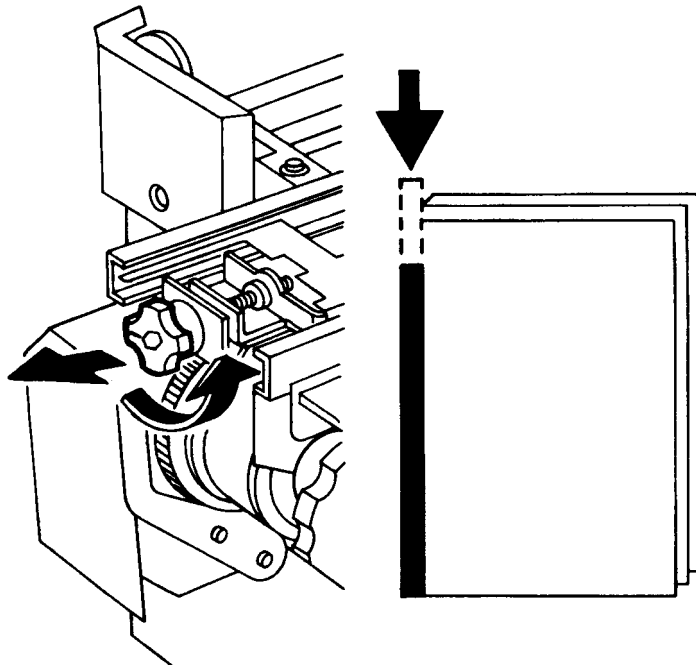

XE161A

Figure 3-72 Adjusting the tape position down

8. Close the finisher doors.
9. Run a test binder job to check your adjustment.
10. Perform the procedure again as needed.

4 Problem Solving

The system is designed to help you find and solve problems as they happen. The system detects hardware and software problems, displays error or fault messages and screens, and sounds an alert tone (if it is enabled) when a problem needs to be corrected.

This section of the operator guide describes how the system informs you of problems. When you know there is a system problem, you can take measures suggested by the system to correct the problem. You can also use the problem and solution tables in this section to resolve recurring problems. Included are detailed procedures that are required to resolve some of the problems.

If you are not able to correct a problem, or you have a question about system operation, you should call the Customer Support Center. If a customer support representative cannot solve your problem over the phone, a service representative will be dispatched.

How problems are displayed

Hardware problems show themselves by way of messages, document misfeeds, paper jams, poor prints, fault codes, and system components that do not operate correctly.

Software problems usually show up as messages in the status area of the screen or as fault codes on the fault frames. Some software problems affect hardware behavior. For example, the printer may operate without producing any prints. This is a condition called "dead cycling."

Printer faults and fault windows

When the printer needs attention, it is called a fault. There are three types of faults: those that require immediate attention, those that provide information, and those that require service.

Examples of faults that would require immediate attention are misfeeds in the paper path or paper jams.

Examples of a fault that is informational is low dry ink. If this type of fault is not resolved, a fault requiring immediate attention will result eventually.

When a fault occurs

When a fault occurs in the printer an indicator appears on the DocuSP Print Services window and a Printer Faults message appears.



NOTE: *The printers also have an attention light on top of the finisher module. A flashing light indicates a fault requiring immediate attention; a steady light indicates a fault that can be cleared at a later time.*

Refer to the on-line help or System Guide for additional information on printer faults.

Resolving a processor problem

If you have a recurring processor problem, perform the following activities:

- Find the problem in the Problem column of the problem solving charts below.
- Follow the instructions in the Suggested solutions column of the problem solving charts in this guide.



WARNING: *Remember that the fuser and binder area surfaces are hot. Proceed with caution when clearing all jams.*

Table 4-1. Resolving a processor problem

Problem	Suggested Solution
Paper tray elevator fails to rise or lower	<ul style="list-style-type: none"> • Ensure that the stock is loaded properly in the paper trays, with the rear and side guides against the stock stack. • If the elevator fails to rise or lower in paper tray 1 or 2, latch the paper feeder by pressing down on the green dot inside the tray. • Do not slam the trays closed. Push the trays in slowly but firmly. • Ensure that all misfed stock has been removed from the immediate area of the paper trays.

Problem	Suggested Solution
Paper path jams	<ul style="list-style-type: none"> • Check the area where the jams are occurring to ensure that the paper path is clear of paper and other obstructions. • If a jammed sheet of paper tears when being removed, ensure that you have removed all of the sheet pieces. • Ensure that the paper path baffles are in the correct seated position. • Ensure that the stock is loaded properly in the trays, with the rear and side guides against the stack. • Ensure that the stock is not loaded above the bottom of the red line in the paper tray. • Ensure that the stock has no bent corners, or tears, and that the edges are straight. Remove any damaged sheets. • Repeated jamming may be due to a paper curl problem that can be resolved by adjusting the decurler lever. Refer to the procedure, "Adjusting for paper curl," in this guide. • Paper weight less than substance 20 (75 g/m²) will require careful setting of the decurler. Refer to the procedure, "Adjusting for paper curl," in this guide. • Fan the stock thoroughly. • Ensure that the stock is within the limitations described in the satisfaction guides in the "Technical information" chapter. • Paper weight less than substance 20 (75 g/m²) will require careful storage and handling. Refer to the "Technical information" chapter.
Paper misfeeds and multifeeds	<ul style="list-style-type: none"> • Ensure that the stock is loaded properly in the paper trays, with the rear and side guides against the stack. • Ensure that the stock is not loaded above the bottom of the red line in the paper tray. • Ensure that the stock has no bent corners, or tears, and that the edges are straight. Remove any damaged sheets. • Check the sheets in the bottom of the paper tray for damage. If they are damaged, discard the sheets. • Ensure that the stock to be fed out of the paper tray is not excessively curled. Refer to the procedure, "Adjusting for paper curl," in this guide. • If the misfeeds are occurring in the paper tray, ensure that the paper feeder is latched by pressing down on the green dot inside the tray. • Fan the stock at all four corners. Change it if it has uneven edges or if it was not drilled properly. • The stock should be kept in the original wrapper and stored correctly. Refer to the "Technical information" chapter. • Ensure that the stock is within the limits described in the "Technical information" chapter.

Problem	Suggested Solution
Missing sheets in a set immediately after a jam.	After recovering from a jam, an incomplete set may be purged and the set reprinted. Check the prints to ensure that you are not confusing the purged output with the completed set.
Printer is dead cycling; it is running, but not making any prints	If the printer is running, but not making any prints, and no message is displayed on the screen, open a processor door to stop the printer. If this problem repeats, refer to the procedure, "Calling for assistance," in this guide.
Fuser jams	<p>WARNING: <i>The fuser surfaces are hot. To avoid injury, proceed with caution when removing all jams. Use a piece of paper to remove jammed sheets from the fuser.</i></p> <p>The jammed sheets in the fuser require careful handling because they may not be fused properly.</p> <p>Images that extend all the way to the edge of the prints may cause increased frequency of jams.</p> <ul style="list-style-type: none"> • Do not place dense images to be printed at the right or left lead and trail edges of the paper. This may cause fuser jams. • If the above adjustment does not resolve the problem, contact the Site Administrator to access the Lead Edge Screening feature on the Printer Switches window. <p>There are three settings available in the Lead Edge Screening feature:</p> <ul style="list-style-type: none"> • Use the Off setting when it is necessary to print all of the document. • Use the Standard setting when the documents have narrow black lines or no dark areas on the lead edge. This is the system default setting and is the recommended setting. • Use the Stress setting when the system is experiencing fuser jams and the Standard option is selected. • Use the Erase All Edges setting when the system is experiencing jams and the image prints to the edges of the paper.
Holes are on the wrong side of the prints	Ensure that the stock is loaded correctly. Refer to the label on the tray.
Paper curl	Adjust the decurler. Refer to the procedure, "Adjusting for paper curl," in this guide.
Fault Code P10-216	This is a printer problem. Switch the printer off and on. Allow a minimum of 30 seconds between switching the printer off and switching the printer back on.
Fault Code P09-418	If this fault is persistent, replace the wire module. If the fault continues, call for service. Refer to the wire module removal and replacement procedure in this guide.

Problem	Suggested Solution
<p>Processor power is off unexpectedly</p>	<p>The processor or the DocuSP controller may have an electrical problem. If the DocuSP controller has an electrical problem, it may shut off the power to the processor.</p> <ol style="list-style-type: none"> 1. Determine if the DocuSP controller power and the processor power are off. <ul style="list-style-type: none"> • If the controller's screen is blank and the power-indicator light is not blinking, the controller power is off. Refer to the System Guide • If the paper tray lights are out, the power to the processor is off. Proceed with step 2. 2. Determine if the processor has a ground fault protector. If there is not a ground fault protector installed, refer to the procedure "Calling for assistance," in this guide. 3. If the processor has a ground fault protector, determine whether the protector has shut off the power. <ul style="list-style-type: none"> • If the red light is visible on the protector, proceed with step 4. • If the red light is not visible, something other than the protector has shut off the power. Refer to the problem "Processor power is off unexpectedly, and the ground fault protector did not trip," in this section. 4. Press the reset button on the processor ground fault protector. <ul style="list-style-type: none"> • If the red light switches off, proceed with step 5. • If the red light does not switch off, or immediately switches on again, refer to the procedure, "Calling for assistance", in this guide. 5. Switch the white-handled circuit breakers near the protector to the on (up) position. <ul style="list-style-type: none"> • If the power comes on, proceed with step 6. • If the circuit breakers immediately switch off again, refer to the procedure, "Calling for assistance," in this guide. 6. Select the Reset icon on the fault frame. This should clear the fault. 7. Clear any other faults that may be declared. Do not clear the paper path unless directed to do so. The system will maintain job integrity. 8. If the power repeatedly switches off unexpectedly, refer to the procedure, "Calling for assistance," in this guide.
<p>Processor power is off unexpectedly, and the ground fault protector did not trip</p>	<ol style="list-style-type: none"> 1. Select the Reset icon on the fault frame. 2. Call for maintenance or electrical assistance within your facility in order to determine whether power is available at the electrical panel box within your facility. 3. Do not clear the paper path unless directed to do so. The system will maintain job integrity.

Solving print quality problems

A print quality problem means that the job was submitted successfully, but does not print correctly.



NOTE: *If the Image Quality parameters are changed, you must restart or reboot the DocuSP software in order for the changes to take affect.*



NOTE: *The image quality default settings are optimized for the printer. If changes have been made, you can restore the factory installed defaults by selecting [Defaults]. Selecting [Reset] sets the image quality parameters to the most recently applied setting.*

Clearing paper jams

The paper path is the route that materials (paper, transparencies, labels, and so on) follow through the printer from the feeder trays to the stacker bins, sample tray, or purge tray. Paper jams can occur at any stage of the paper path. After a paper jam the printer stops, and the following happens:

- If enabled, the Attention light flashes.
- Messages appear on the controller informing you of the paper jam and its location in the printer.
- Selecting the message displays a printer mimic graphic that shows the area of a paper jam and lists instructions for clearing the jam.



NOTE: *It is important that you clear the sheets only in the areas indicated on the controller.*

Checking job integrity following a paper jam

When printing resumes following a paper jam, there is a slight possibility that duplicate sheets may be printed or sheets may be missing from a job. For that reason, you should check job integrity after the job has been printed.

1. The printer offsets the first sheet printed following a paper jam. Locate that sheet in the stack.
2. Check the sheets immediately before and after the offset sheet to see if there are any missing or duplicate sheets in the output.



NOTE: *A message may appear on the controller screen telling you that there is a suspected page delivery error and advising you to check the output.*

Clearing paper jams in printer areas 2 through 10 for both configurations

In the following figures, the printer jam clearance areas have arrows pointing to them or circles drawn around them.

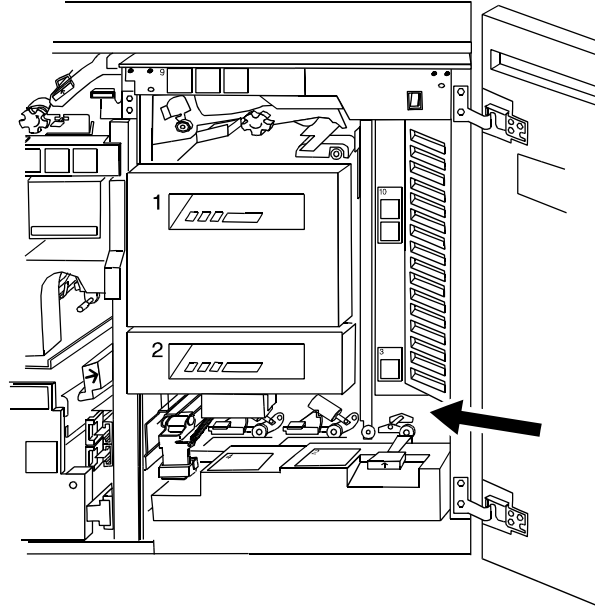

Figure 4-1 Area 2

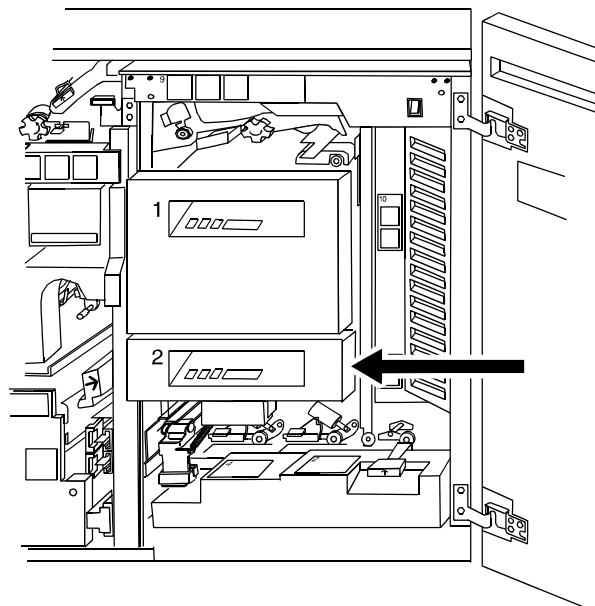

Figure 4-2 Area 3

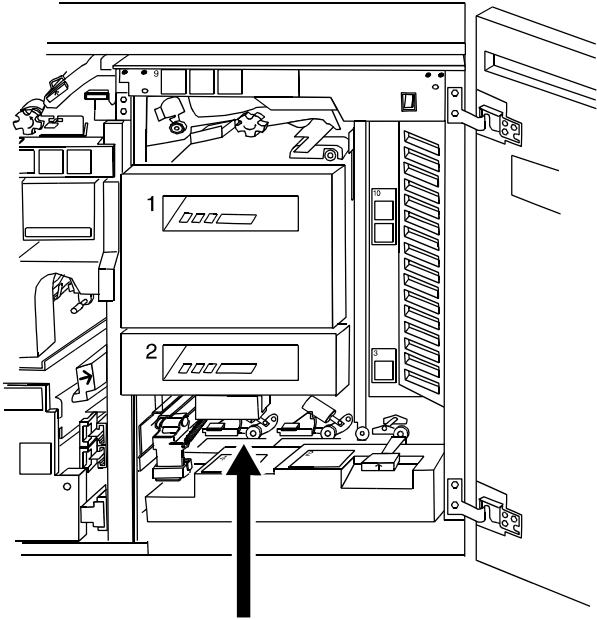

Figure 4-3 Area 4

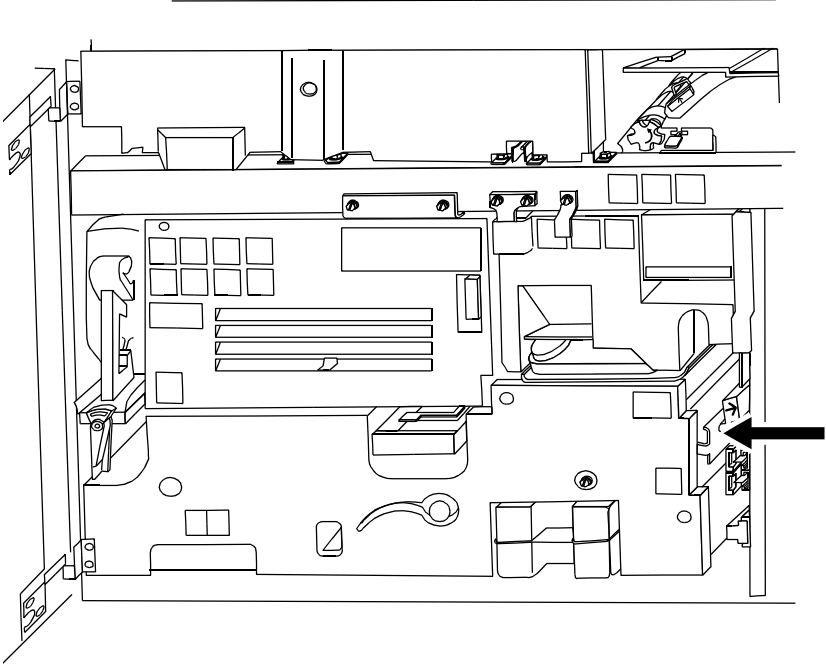

Figure 4-4 Area 5

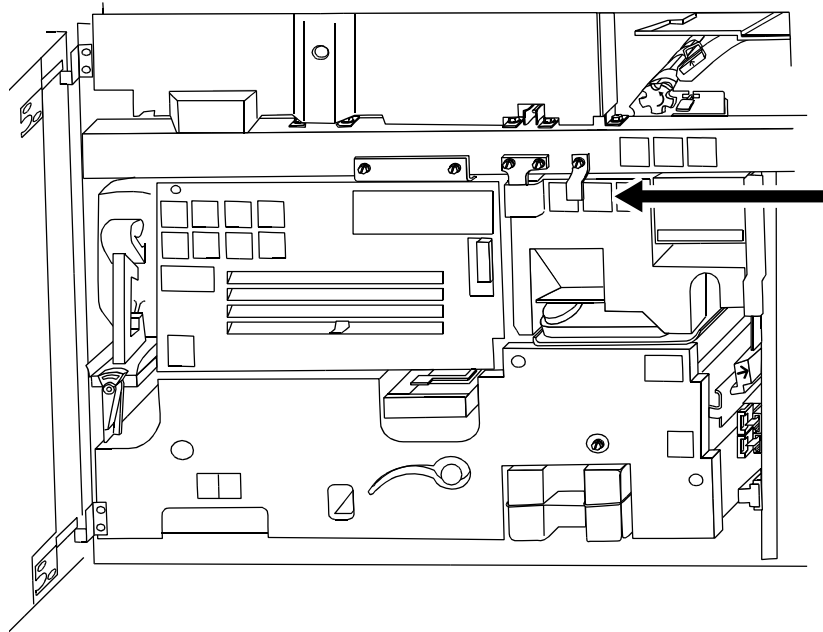

Figure 4-5 Area 6

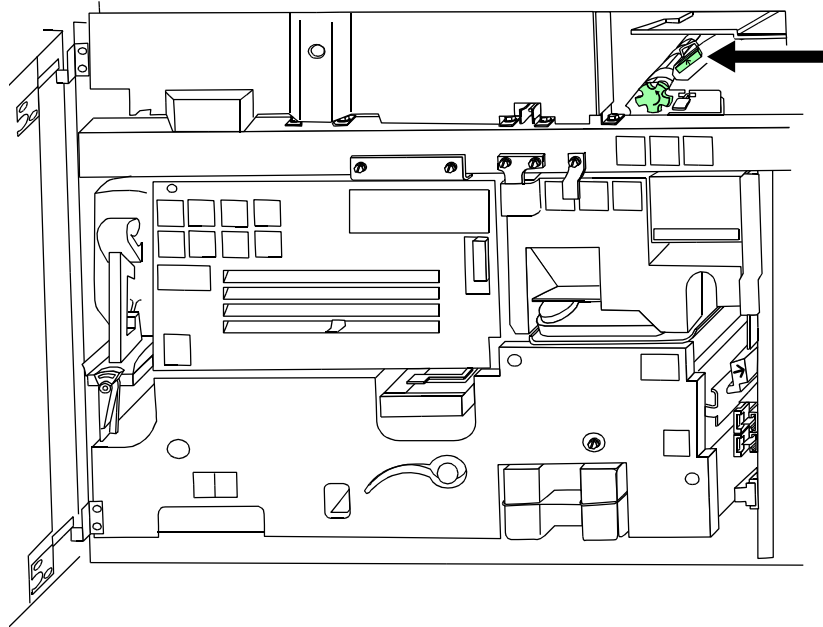

Figure 4-6 Area 7

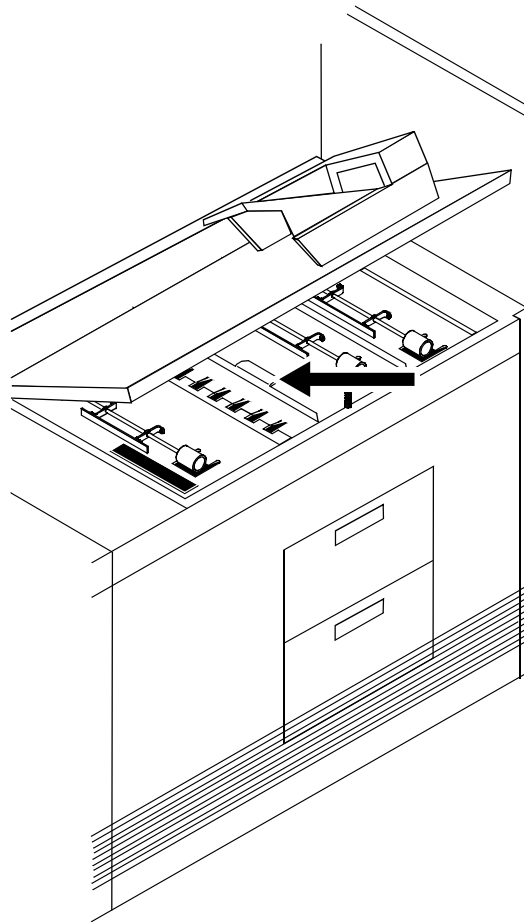

Figure 4-7 Area 8



NOTE: *If a jammed sheet rips as you are removing it from area 8, you may have to use the pinch lever in area 9 to remove the paper. Refer to the Note following the area 14 figure for additional instructions.*

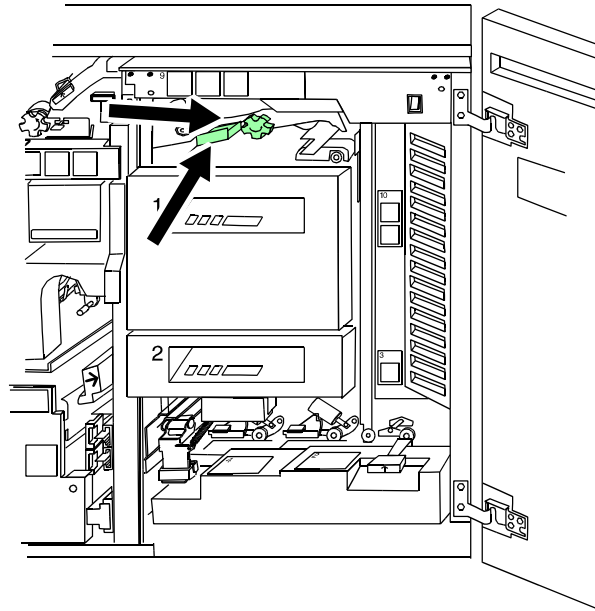

Figure 4-8 Area 9

To clear jams from area 9:

1. Lower and pull out tray 1 to give you better access to area 9.
2. Pull the area 9 green lever toward you to unlatch it. Be sure to relatch the lever after you have cleared any paper in this area. To further facilitate removing sheets wedged in this area, pull out tray 1 and hold the green lever down.
3. Turn the green knob located to the right of the lever to move jammed sheets further along the paper path to where they are more accessible and easier to remove.
4. If paper rips as you are removing it from area 9, or if you have difficulty removing paper from this area, use the pinch lever located further inside area 9. Paper may be caught in this area during duplex printing.



CAUTION: *This area of the printer may be hot. Be careful when inserting your hand.*

Using the pinch lever to access area 9

To use the pinch lever located inside area 9:

1. Locate the green pinch lever directly behind area 9 (above the green knob and further inside area 9).
2. Carefully reaching your hand into the area, squeeze the edges of the pinch lever and lift it up.
3. Remove any paper caught in this area.
4. Turn the green pinch lever to its original position. Make sure that you relatch the lever after you have cleared any paper in this area.

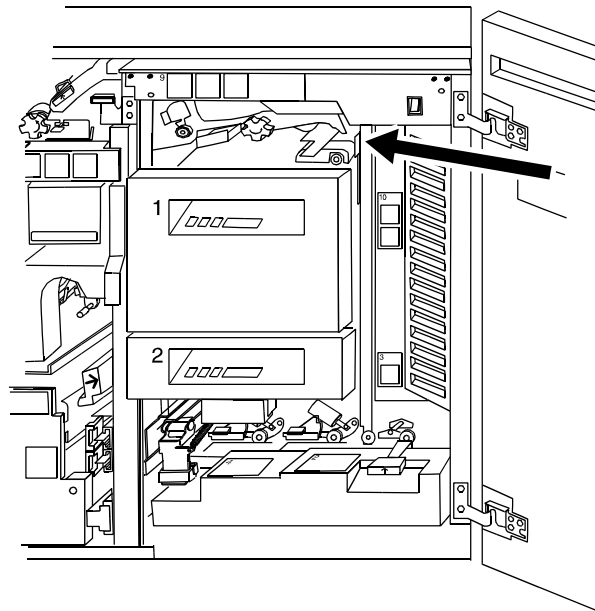

Figure 4-9 Area 10

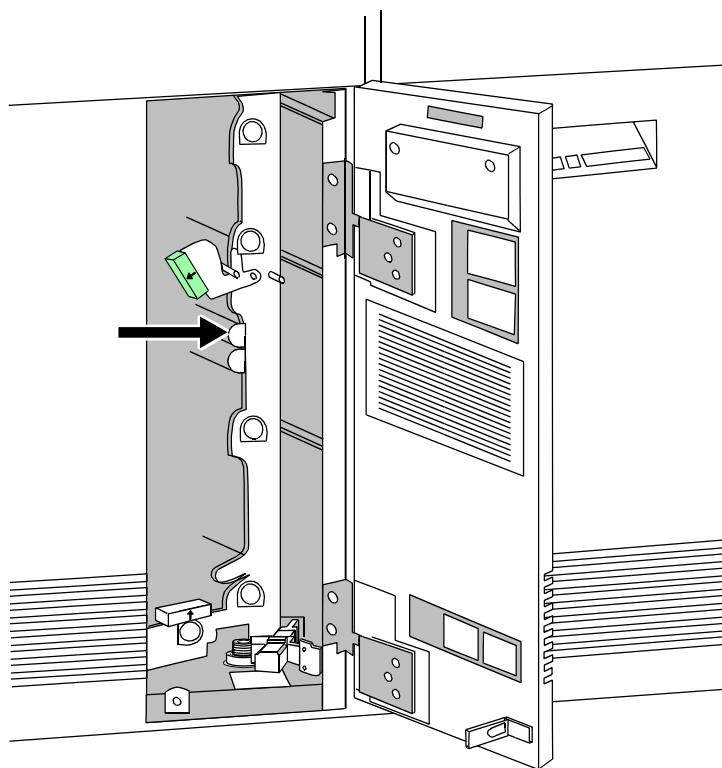

Figure 4-10 Area 11 (all feeder/stackers)



NOTE: *High volume printer configuration only*

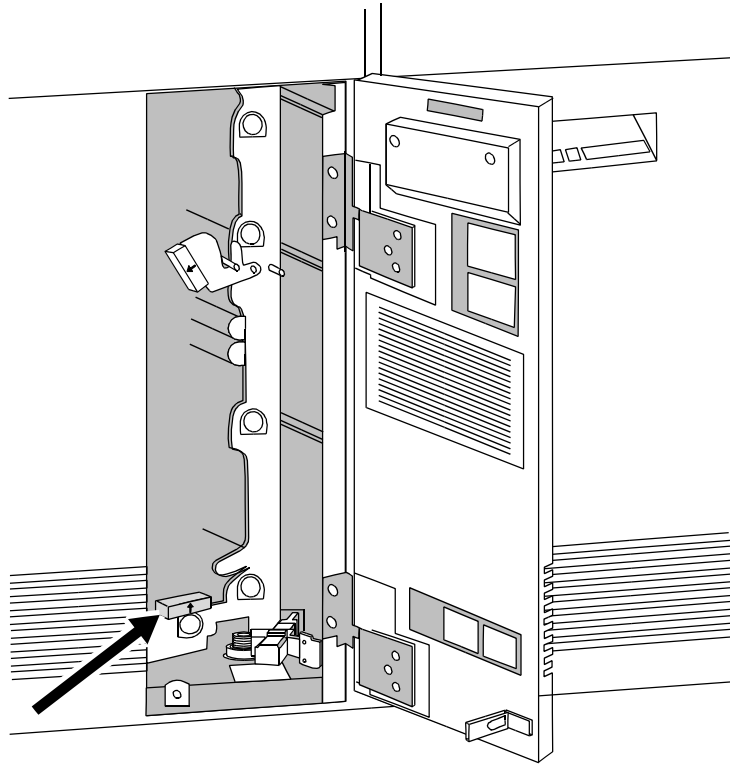

Figure 4-11 Area 12 (all feeder/stackers)



NOTE: *High volume printer configuration only*

Clearing paper jams in the Feeder/Stackers

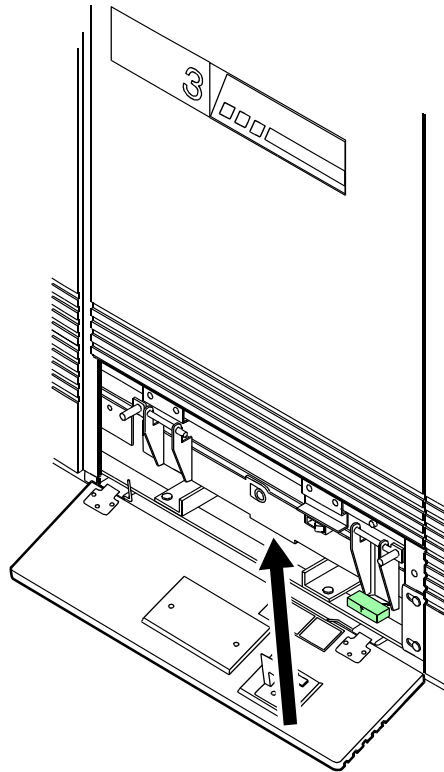

Figure 4-12 Area 13



NOTE: Figures 4-12 and 4-13 applicable on the high volume printer configuration only.

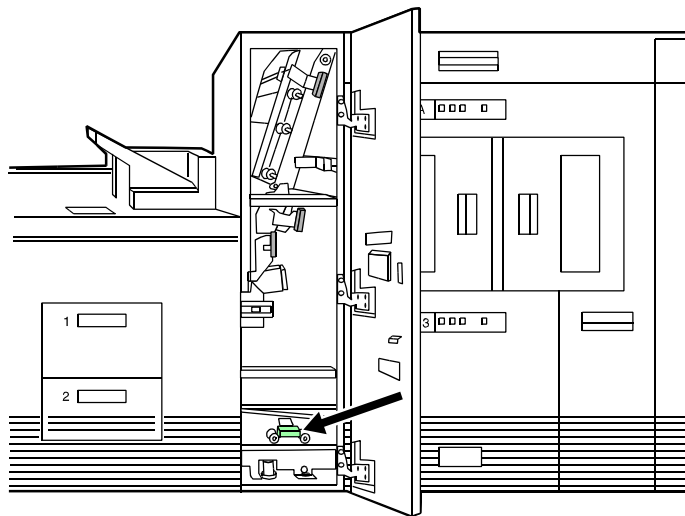

Figure 4-13 Area 14



NOTE: You may sometimes find paper lying on top of area 14, even though there is no message indicating a jam in this area. Discard the paper.

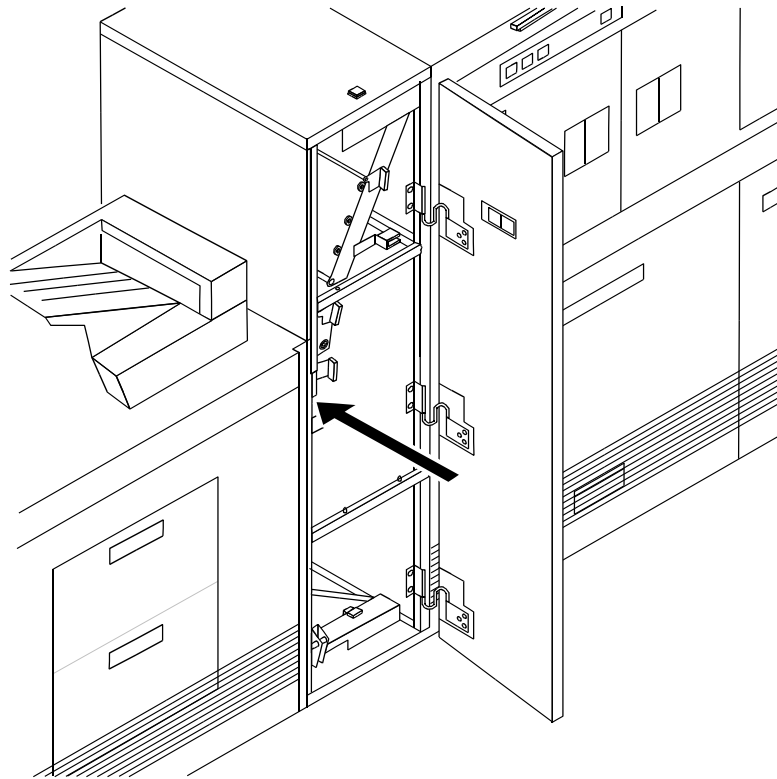

Figure 4-14 Area 15



NOTE: High volume printer configuration only

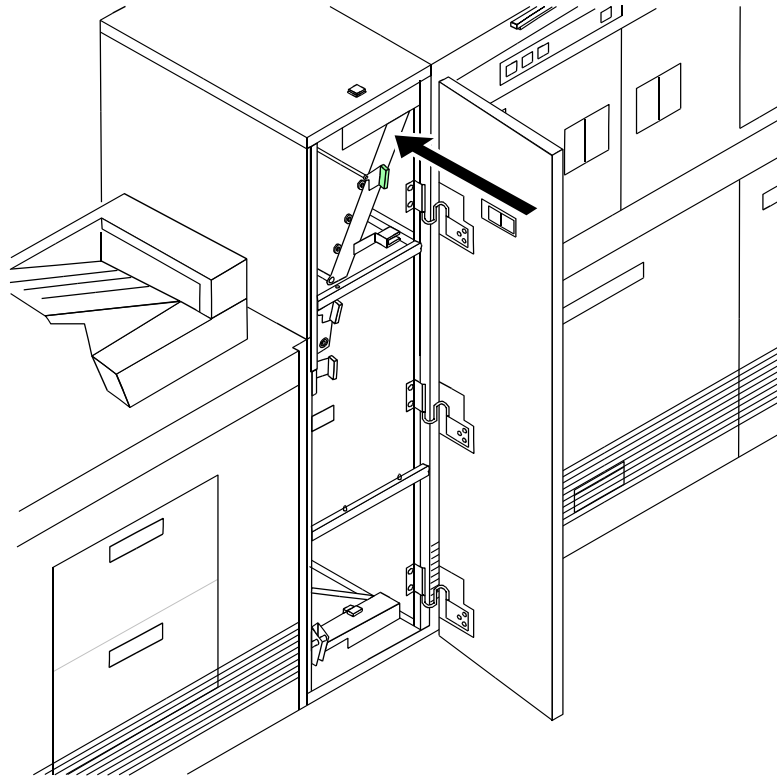

Figure 4-15 Area 16



NOTE: *High volume printer configuration only*

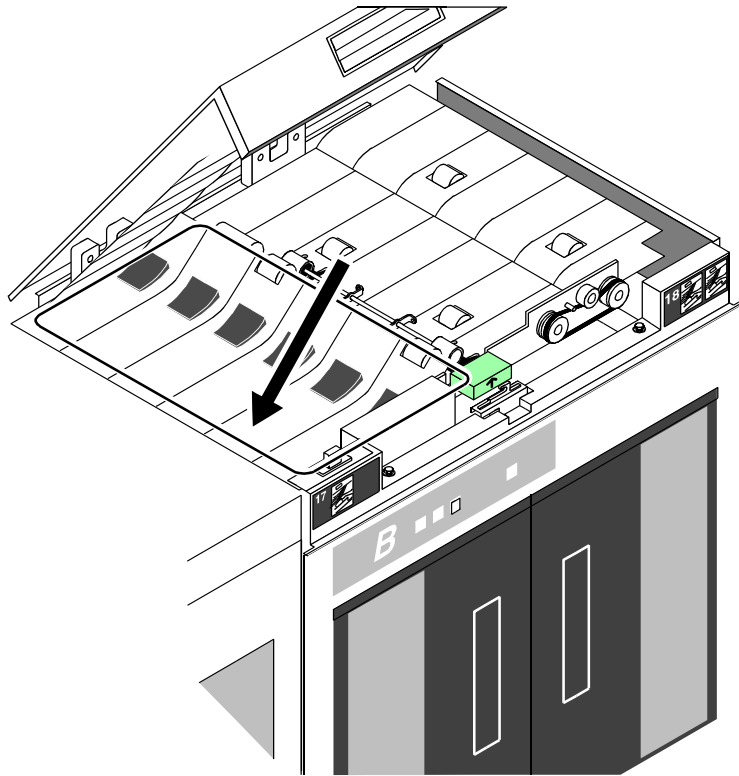

Figure 4-16 Area 17



NOTE: *If your printer has frequent jams in this area, you may need to clean the Q1106 sensor.*



NOTE: *High volume printer configuration only*

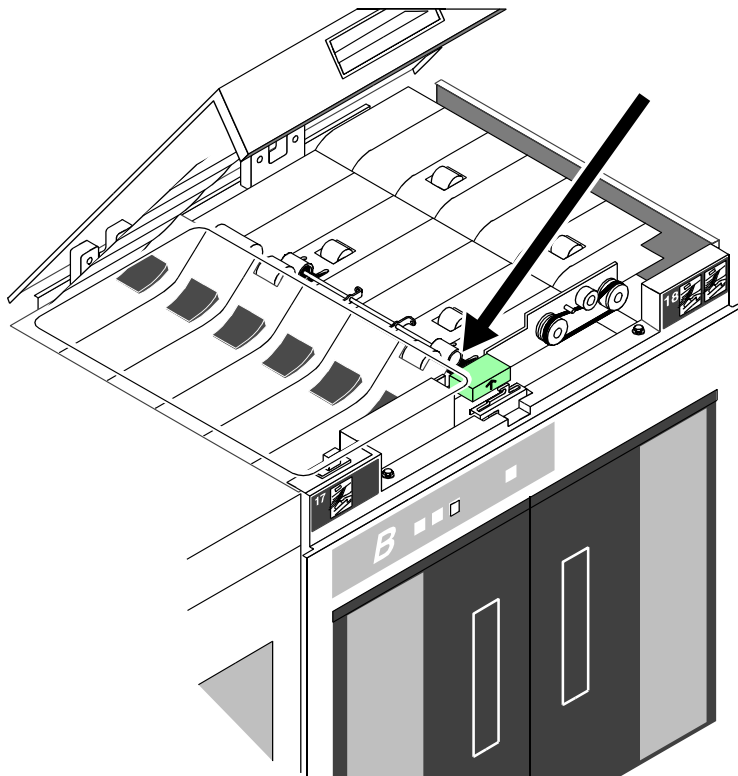

Figure 4-17 Area 18

Points to note for clearing jams in area 18:

- Sometimes the controller messages direct you to discard the last sheet delivered to the stack following a jam in area 18. Check for this message when clearing an area 18 paper jam.
- If your printer has frequent jams in this area, you may need to clean the Q1107 sensor.
- If your printer has a bypass transport module, you should check for paper jams in areas 19 and 20 after clearing an area 18 paper jam.

Clearing a paper jam in the bypass transport



NOTE: *High volume printer configuration only*

1. Open the bypass transport module door.
2. Press the area 19 green lever in the direction of the arrow printed on it.

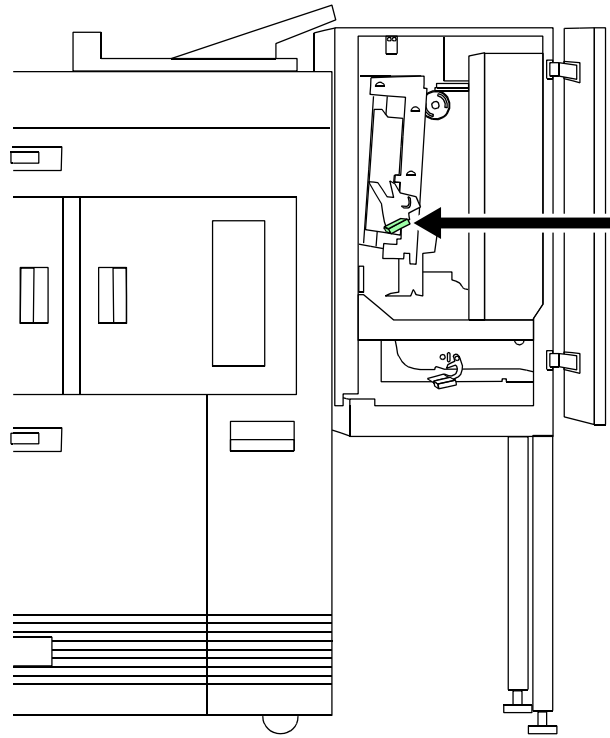

Figure 4-18 Area 19

3. Remove any paper from the exposed area.
4. Press the green lever to the left until the latch catches.
5. Press the area 20 green lever in the direction of the arrow printed on it.

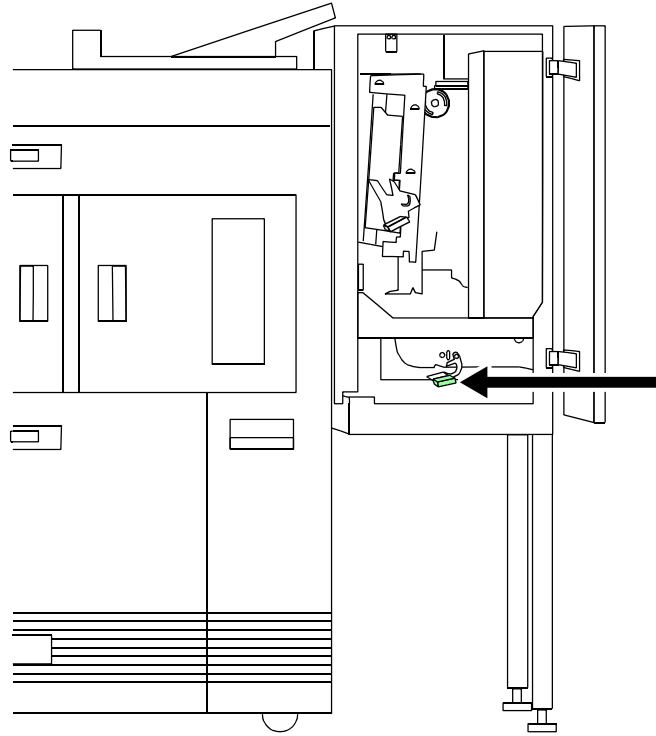

Figure 4-19 Area 20

6. Remove any paper from the exposed area.
7. Press the green lever down and to the left until the latch catches.
8. Close the bypass transport module door.

Clearing a misfeed (feeder tray fault)



NOTE: *High volume printer configuration only*

1. If the Ready to Open indicator is not lit, press the Tray Unlock button located on the feeder tray control panel.

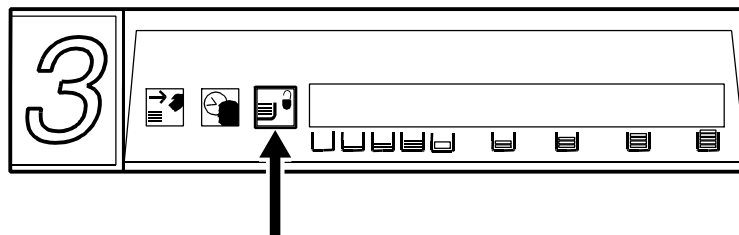

Figure 4-20

2. When the Ready to Open indicator lights, open the feeder tray. Pull the tray all the way out for best results.

3. For the processor feeder trays, press the green lever to unlatch the paper feeder assembly.

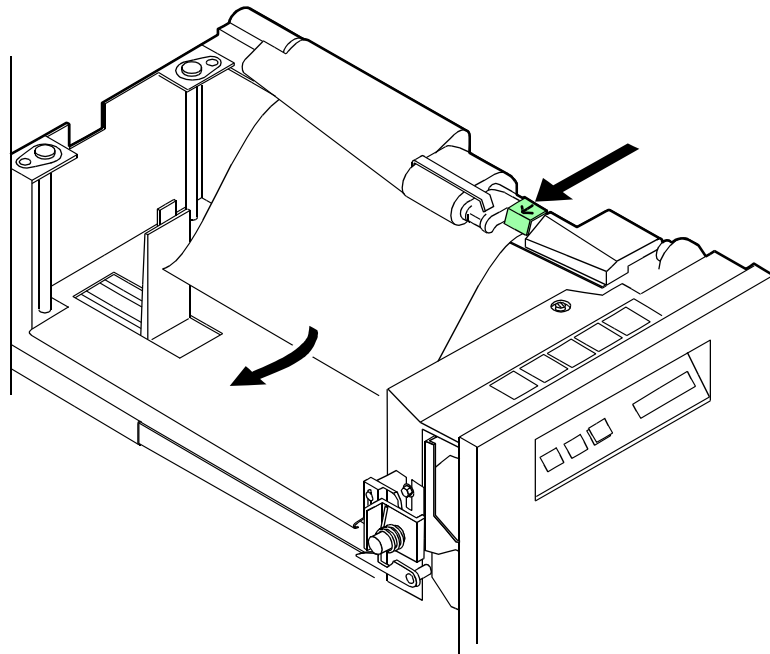

Figure 4-21

4. Remove and discard any partially fed paper. Ensure that:
 - The paper supply is neatly stacked.
 - The stack is not higher than the MAX line on the length guide.
 - The length guide is firmly touching the back edge of the stack.
 - For the high capacity feeder trays, also ensure the side guide is firmly touching the side of the stack.



NOTE: *You do not need to discard transparencies and other stiff materials unless they are damaged.*

5. For the processor feeder trays, relatch the paper feeder assembly by pressing the green dot until the assembly clicks into place.

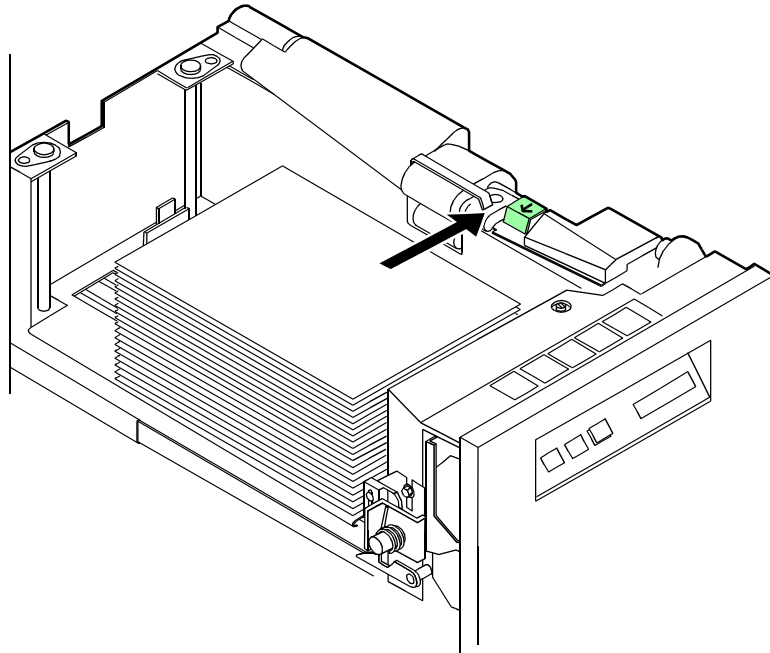

Figure 4-22

6. Slide the tray back into the printer until the tray latches and press the Continue button to resume printing.
7. Discard any pages sent to the sample tray, purge tray, or unused stacker bin when the misfeed was detected.

Incorrect paper size message

Perform this procedure when printing stops and a incorrect paper size message appears on the controller.

1. Check the paper in the indicated tray. If the paper is not the correct size for the job, either load the correct size paper or select another feeder tray containing the correct size paper.
2. If the paper size is correct, press the Continue button to resume printing. The message may have been caused by a damaged sheet.



NOTE: *In order to assure good print quality for your jobs, the printer purges any dog-eared or skewed sheets. In addition, the printer may stop and issue an incorrect paper size message.*

Interposer problems



NOTE: *Production publisher configuration only*

Table 4-2. Resolving an interposer problem

Problem	Suggested solutions
Repeated jams in interposer	<p>Follow the jam clearance diagram in the Printer Fault Clearance window carefully to ensure all paper has been cleared.</p> <p>Make sure the stock in trays 4 and 5 have been loaded correctly. Refer to the Satisfaction guides in chapter 4, "Technical Information", for information on loading stock in trays 4 and 5.</p> <p>Make sure the stock in trays 4 and 5 meet the specifications for these trays as indicated in the Satisfaction guides in chapter 4, "Technical Information".</p>

Finisher problems



NOTE: *Production publisher configuration only*

Table 4-3. Resolving a finisher problem

Problem	Suggested solutions
Repeated jams in area 14 (bindexer)	<p>The bindexer contains three bins used by the system to sort sets. The capacity of each bin is 125 sheets of substance 20 (75 g/m²) or 0.5 inch (13 mm) thickness.</p> <p>Include inserts and covers when considering the output capacity of the bindexer.</p> <p>125 sheets of substance 20 (75 g/m²) is equal to approximately: 104 sheets of substance 24 (90 g/m²) 78 sheets of substance 32 (120 g/m²) 47 sheets of substance 110 (200 g/m²).</p> <p>Check that the sets in the bindexer are less than 0.5 inch (13 mm) thick.</p> <p>If the set exceeds 0.5 inch (13 mm) thickness, reprogram the job for fewer sheets or reduce the number of heavy-weight sheets.</p> <p>When running collated, unfinished sets, the maximum sheet capacity of the bindexer can be set between 50 and 125.</p> <p>When running anything other than collated, unfinished sets, the maximum sheet capacity of the bindexer will remain at 125.</p>
Jammed binder tape, such as binder tape sticking together, or cosmetic defects in the bound book	<p>Replace the tape reel with a new reel using the procedure, "Replacing the binder tape reel," in this guide.</p> <p>Refer to the binder tape reel storage information in this guide.</p>

Table 4-3. Resolving a finisher problem

<p>Binder tape not positioned correctly on the top edge of the output prints</p>	<p>Adjust the binder tape registration using the procedure, "Adjusting the binder tape registration," in this guide.</p>
<p>Binder tape is too long or too short on the bottom edge of the output prints</p>	<p>Adjust the binder tape length using the procedure entitled "Adjusting the binder tape registration" in the "Routine maintenance" chapter. If an adjustment is made to the binder tape length during a job, it will not take effect until the next job is printed. If it is necessary to adjust the binder tape length during a job, adjust it using the procedures in the on-line help.</p>
<p>Loose binder tape along the spine of the completed bound book</p>	<p>This is a symptom of excessive moisture in the tape. Replace the tape reel with a new reel using the procedure, "Replacing the binder tape reel," in the "Routine maintenance" chapter. Refer to the binder tape storage guidelines in this guide.</p>
<p>Repeated tape feeding problems, such as binder tape not unwinding from the reel</p>	<p>If the binder tape is sticking together, or if there are cosmetic defects in the bound book, replace the tape reel with a new reel using the procedure, "Replacing the binder tape reel," in the "Routine maintenance" chapter. Refer to the binder tape storage information in this guide. Refer to the binder cleaning information in this guide. Refer to information on calling the Customer Support Center in this guide.</p>
<p>Stitcher fault codes displayed in the fault frame Fault Code P12-218 Fault Code P12-219</p>	<p>Select the [Finishing] button on the Printer Manager window. Deselect [Stitcher] on the Finishing window and refer to the procedure, "Calling for assistance," in this guide. Stitcher A problems. Perform the procedure, "Clearing a stitcher spool A fault," in this guide. Stitcher B problems. Refer to information on calling the Customer Support Center in this guide.</p>
<p>Poor stitch quality or short stitches</p>	<p>Reliable stitching can be expected with up to 65 sheets of substance 20 (75 g/m²) or 0.28 inch (7 mm) thick sets. Less reliable stitching can be expected with over 70 sheets of substance 20 (75 g/m²). Running intermixed stock heavier than substance 20 (75 g/m²) will reduce the capacity of the stitcher. To avoid short clinches, use the stitch override only when using a lightweight paper. Stitch override allows the system to run beyond the stitching limit. The system will shut down at 125 sheets. Reduce the stock weight to enable the stitching of more sheets per set. Refer to the satisfaction guides in the "Technical information" chapter.</p>

Table 4-3. Resolving a finisher problem

Sheets are spilling out of the top tray	<p>The capacity of the top tray is 500 sheets of substance 20 (75 g/m²) or 2 inches (51 mm) in height. When intermixed stock or paper heavier than substance 20 (75 g/m²) is being run, the capacity of the top tray is reduced.</p> <p>500 sheets of substance 20 (75 g/m²) is equal to approximately: 415 sheets of substance 24 (90 g/m²) 310 sheets of substance 32 (120 g/m²) 225 sheets of substance 110 (200 g/m²)</p> <p>If using any paper heavier than substance 20 (75 g/m²) or intermixed stock of different weights, unload the top tray before the count in the tray reaches its capacity limit.</p> <p>Refer to the satisfaction guides in the "Technical information" chapter.</p>
---	--

Binder tape fault



NOTE: *Production publisher configuration only*

To clear a binder tape fault:

1. Open the finisher doors.
2. Open the top cover.



WARNING: *The binder tape adhesive is hot, approximately 425°F (218°C). Allow the binder to cool for 5 minutes with the finisher doors and top cover open before touching the binder tape.*

3. Follow the instructions on the screen to determine the area (17 or 18) that should be cleared.
4. If area 17 is displayed and the binder tape is present, stop and follow the WARNING. Remove the binder tape and paper. Proceed to step 6.
5. If area 17 is displayed and the binder tape is not present, follow the instructions on the area 17 label and remove all paper.
6. Ensure that area 17 is clear of all binder tape adhesive. If the area is not clear, clean the binder using the procedure, "Cleaning the binder," in this guide.



WARNING: *The binder tape adhesive is hot, approximately 425°F (218°C). Allow the binder to cool for 5 minutes with the finisher doors and top cover open before touching the binder tape.*

7. If area 18 is not displayed, proceed to step 10.
8. If area 18 is displayed and the entire binder tape length is not aligned with the tape feeder assembly, stop and follow the WARNING. Proceed to step 10.
9. If area 18 is displayed and the entire binder tape length is aligned with the tape feeder assembly, proceed to step 10.
10. Remove the binder tape.

11. Ensure that area 18 is clear of all binder tape adhesive. If it is not, clean the binder using the procedure, "Cleaning the binder," in the "Routine maintenance" chapter.
12. Close the finisher doors.
13. Close the top cover.

Stitcher spool A fault



NOTE: *Production publisher configuration only*

Repeated jams in area 17 may be caused by the following problems:

- Stitcher wire not feeding properly
 - A kink in the stitcher wire
1. Open the finisher doors.
 2. Lift the stitcher panel, which is located directly above the stitcher spools.

NOTE: *If the spool is empty, replace the stitcher spool A. Refer to online help for details.*

3. Ensure that there is wire on the spool.
4. Pull the green stitcher head release handle forward and up until it latches into place, as shown in figure 4-23.

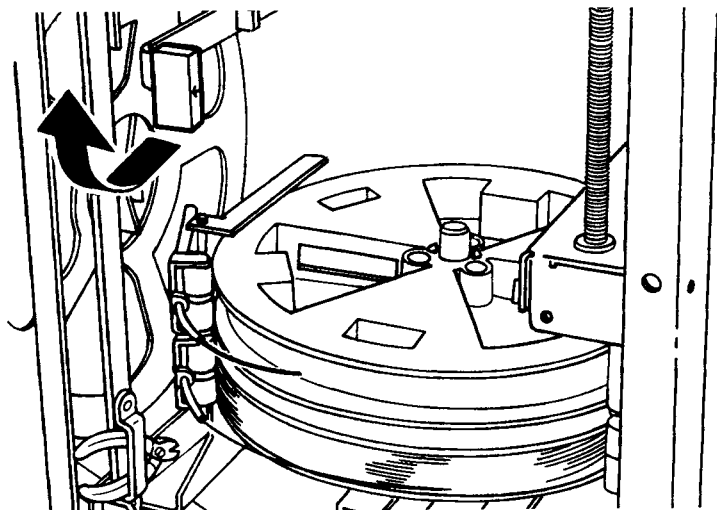

XE059D

Figure 4-23 Stitcher head release handle

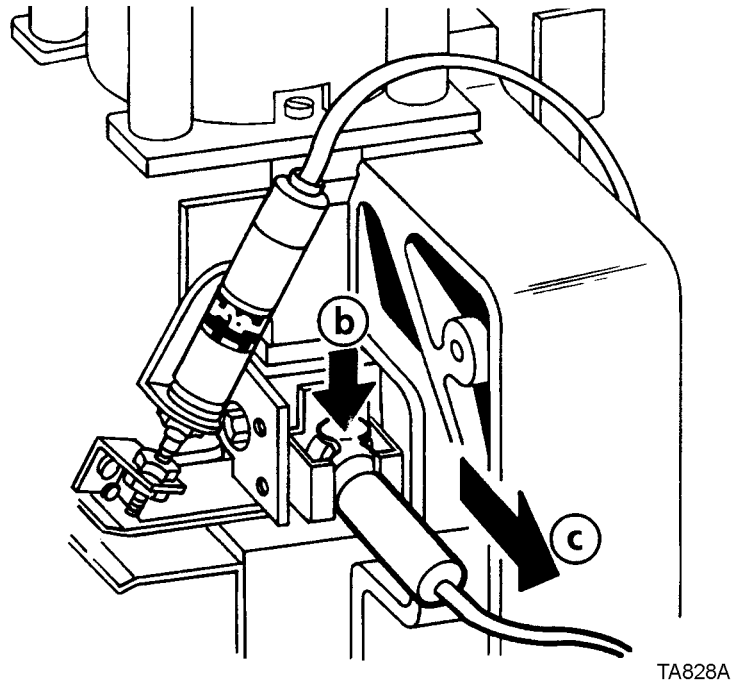
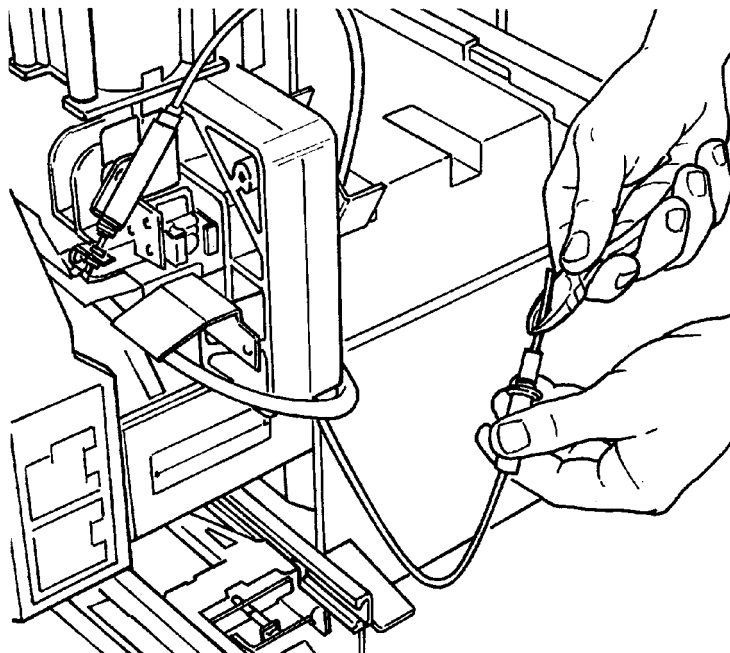

Figure 4-24 Removing the stitcher wire plug

5. Remove the stitcher wire plug.
 - The stitcher wire plug is located above the binder area, as shown in figure 4-24.
 - Press and hold down the release clip.
 - Pull the plug out of the stitcher head.
6. Remove any damaged wire.
 - Using the wire cutters, slowly and carefully pull approximately 3 feet (1 meter) of wire out of the stitcher plug.
 - The wire cutter tool needed to perform this procedure is located next to stitcher spool B, as shown in the lower left corner of figure 4-23.
 - Cut the wire carefully, leaving approximately 2 inches (50 mm) of wire extending from the stitcher plug, as shown in figure 4-25.



XEA084A

Figure 4-25 Cutting the wire

7. Insert the plug into the measuring bracket, as shown in figure 4-26.

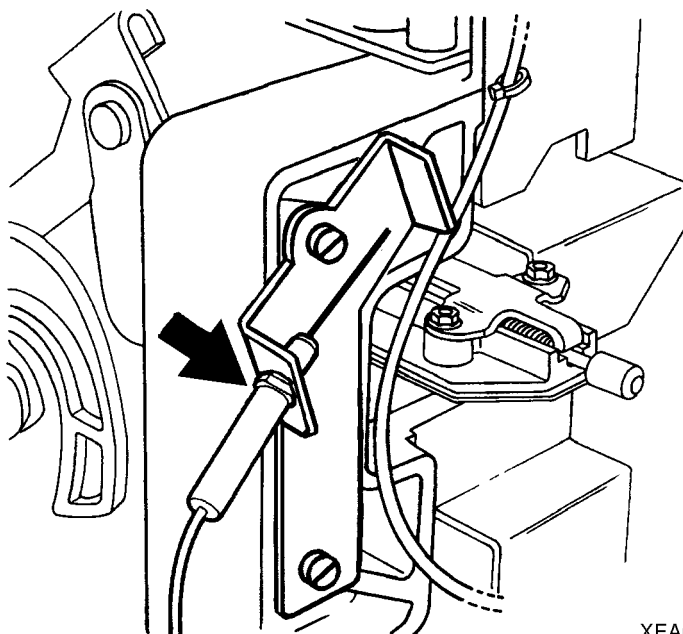

XEA085A

Figure 4-26 The measuring bracket

8. Feed the wire until the wire touches the back of the measuring bracket.
9. Remove any stitcher wire fragments.

- Fold a piece of copy paper in half lengthwise. Place the folded sheet of copy paper under the stitcher head, as shown in figure 4-27.
- Pull out the stitcher knob and allow it to snap back into place to free any stitcher wire fragments.
- Remove the copy paper carefully, being sure not to drop any wire fragments into the system.

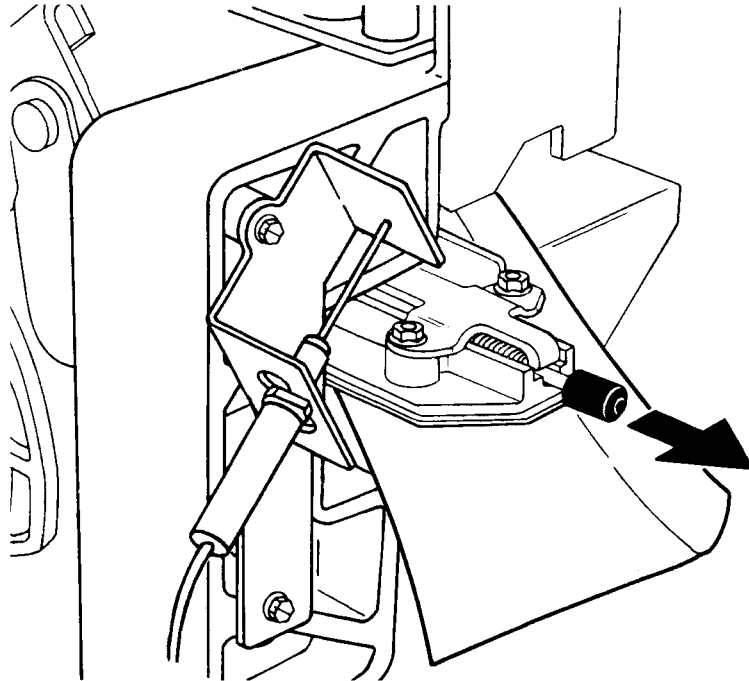

XE175A

Figure 4-27 Removing the wire fragments

10. Push the green stitcher head release handle down and back.
11. Pull the plug from the measuring bracket.
12. Insert the plug into the stitcher head until the plug snaps into place.

NOTE: *Ensure that the wire cutters are not touching the stitcher spools. This can prevent the stitcher wire from feeding properly.*

13. Place the wire cutters in the storage bracket.

NOTE: *Ensure that the stitcher panel has been lowered. The stacker will not deliver printed sets if the stitcher panel is left in the up position*

14. Lower the stitcher panel.
15. Close the finisher doors. The printer icon indicates "Ready."

Checking paper curl

You can adjust the decurler lever to correct most paper curl problems. Refer to the paper curl chart, later in this chapter, to determine the amount of curl in the paper stock.

Perform the following to measure paper curl:

1. Print five one sided (simplex) 8.5 by 11 inch or A4 sheets.
2. Hold the printed sheets by the top center of the short edge, keeping the image toward you.

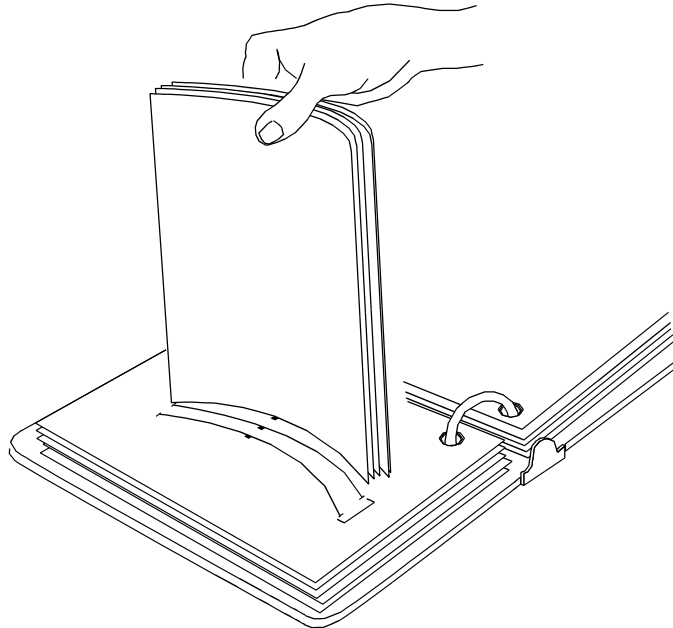

Figure 4-28 Paper curl chart

3. Place the bottom edge of the prints over the paper curl measurement chart on the line that best represents the curve of the sheets.
 - If the curl on the printed paper stock measures between +2 and -2, do not change the decurler setting.
 - If the curl is between +2 and +3, or -3 and -4, adjust the decurler lever.

Customer Support Center

Before calling the Customer Service Support Center for service, ensure you have read this information and have tried the corrective actions described here. If the problem persists, gather the necessary information (details follow) and call the appropriate Customer Service Support Center phone number. Your site

representative can supply you with the telephone number for the Customer Service Support Center in your area.

The correct phone number is attached to your printer at installation time.

Before calling for service, make note of:

- Print, job fault messages, or status messages that appear on the controller
- Indicator lights that may or may not be lit
- Status codes that appear in the message display of the tape drive control panel if there is a tape drive problem

Your call is answered by a representative who asks you for your equipment model. You are also asked for:

- Your printing system serial number, which is located on a panel inside the printer, behind the small door on the left.

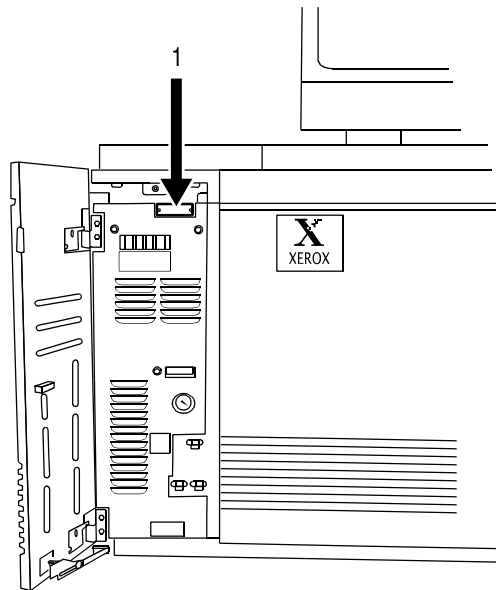

Figure 4-29 Location of printing system serial number

- Your name
- Your company name
- The system condition or status



NOTE: *The printer serial number and fault codes can also be seen on the Tools display of the printer control console.*

This information is given to a customer service representative who calls you back to discuss the information and gives you an estimated time of arrival or to assist you over the phone to resolve the problem.

5 Technical information

This section contains the hardware and software capacity guidelines for the DocuTech HLC systems. It includes the printer specifications, the satisfaction guides for paper trays and stock, and Tips on storing paper and improving printing reliability. For complete system specifications, refer to the appropriate *Installation Planning Guide*.

DocuTech printer specifications

This section contains information on expected print rates for the DocuTech printers, as well as information on the weight, sizes, and capacities for their paper trays.

Printer rates

**Print rate
(per minute)**

DT HLC 180: 180 prints per minute - 8.5 x 11 inch (216 x 279 mm), 8.5 x 14 inch (216 x 254 mm), and A4 stock; 77 prints - 17 x 11 inch (432 x 279 mm) or A3 stock

DT HLC 155: 155 prints per minute - 8.5 x 11 inch (216 x 279 mm), 8.5 x 14 inch (216 x 254 mm), and A4 stock; fewer prints - 17 x 11 inch (432 x 279 mm) or A3 stock

DT HLC 128: 128 prints per minute - 8.5 x 11 inch (216 x 279 mm), 8.5 x 14 inch (216 x 254 mm), and A4 stock; fewer prints - 17 x 11 inch (432 x 279 mm) or A3 stock

128, 155, or 180 prints - custom stock - depending upon the size specified for the stock

Performance can be less than optimal for the some unique stock sizes. For example, for stock having a process direction dimension that is equal to or greater than 8.6 inches (218 mm) and less than or equal to 9 inches (229 mm) the performance at best will be 175 pages per minute.

Paper tray capacities

**Stock weight
(all trays)**

Substance 16 to 110 (60 to 200 g/m²)

**Tray 1
Stock sizes** US letter (8 1/2 x 11 inches)
US legal (8 1/2 X 14 inches)
9 x 11 inches
A4
8 1/2 x 13 inches
223 x 297 mm
Custom (Width = 8 to 9 inches (203 to 229 mm), Length = 10 to 14 inches (254 to 356 mm))

Capacity 1100 sheets, substance 20 (75 g/m2)

**Tray 2
Stock sizes** US letter (8 1/2 x 11 inches)
US legal (8 1/2 x 14 inches)
9 x 11 inches
A4
8 1/2 x 13 inches
223 x 297 mm
Custom (Width = 8 to 9 inches (203 to 229 mm), Length = 10 to 14 inches (254 to 356 mm))

Capacity 600 sheets, substance 20 (75 g/m2)

**Tray 3
Stock Sizes** US Letter (8 1/2 x 11 inches)
US Legal (8 1/2 x 14 inches)
US Ledger (17 x 11 inches)
9 x 11 inches
A3
A4
8 1/2 x 13 inches
223 x 297 mm
ISO B4
JIS B4
Custom (Width = 8 to 17 inches (203 to 432 mm), Length = 10 to 14.33 inches (254 to 364 mm))

Capacity 2600 sheets, substance 20 (75 g/m2)



NOTE: *This tray information is applicable to trays 3-6 on the High volume printer configuration and tray 3 on the Production publisher configuration.*

**Tray 4
Stock Sizes** US Letter (8 1/2 x 11 inches)
US Legal (8 1/2 x 14 inches)

US Ledger (17 x 11 inches)
 9 x 11 inches
 A3
 A4
 8 1/2 x 13 inches
 223 x 297 mm
 ISO B4
 JIS B4
 Custom (Width = 8 to 17 inches (203 to 432 mm), Length = 10 to 14.33 inches (254 to 364 mm))

Capacity 550 sheets, substance 20 (75 g/m²), post-process only

 **NOTE:** *This tray information applies to the Production publisher configuration.*

Tray 5 Stock Sizes

US Letter (8 1/2 x 11 inches)
 US Legal (8 1/2 x 14 inches)
 US Ledger (17 x 11 inches)
 9 x 11 inches
 A3
 A4
 8 1/2 x 13 inches
 223 x 297 mm
 ISO B4
 JIS B4
 Custom (Width = 8 to 17 inches (203 to 432 mm), Length = 10 to 14.33 inches (254 to 364 mm))

Capacity 2600 sheets, substance 20 (75 g/m²), pre or post-process

 **NOTE:** *This tray information applies to the Production publisher configuration.*

Additional paper capacities

Inverter Stock sizes (or duplex tray)
 8 x 10 inches to 17 x 11 inches (203 x 254 mm to 432 x 279 mm)

Top tray Stock sizes 8x10 inches to 17 x 11 inches (203 x 254 mm to 432 x 279 mm)

Capacity 500 sheets, substance 20 (75 g/m²)

Stacker Stock sizes 8 x 10 inches to 9 x 14 inches (203 x 254 mm to 229 x 356 mm)

Capacity	3000 sheets (1500 inboard and 1500 outboard), substance 20 (75 g/m ²)
Stitcher Stock sizes	8 x 10 inches to 9 x 14 inches (203 x 254 mm to 229 x 356 mm)
Capacity	2 to 70 sheets, substance 20 (75 g/m ²)
Stitches per spool	Approximately 35,000
Binder Stock sizes	8.5 x 11 inches (216 x 279 mm)
Capacity	15 sheets (7 sheets with index covers) to 125 sheets of substance 20 (75 g/m ²) or equivalent thickness
Binds per spool	Approximately 425

Printer satisfaction guides

Use the following information to ensure your satisfaction with the feeding of the print material.

Stock storage

Although the system was designed to handle a wide range of stock, many factors can affect performance and print quality.

One of the factors that can affect system performance is paper curl. Humidity and moisture cause the natural paper curl to increase. Too much curl causes jams in the system.

The following practices minimize paper curl during storage of the paper stock.

- Keep the paper wrapped as long as possible. Do not unwrap the paper until it is needed.
- Store the reams of paper in their carton.
- Do not leave the carton directly on the floor. Place something beneath the carton, such as a wooden pallet.

Improving the feeding reliability

The following practices improve the feeding reliability of the system.

- Plan the jobs to minimize the amount of paper left in the system during the night.
- Load the paper quantity based on the number of prints required.
- When paper is taken from a storage area with a different humidity or temperature, keep it in the room where it will be used for at least 48 hours before loading the paper into the system.
- To make adjustments to the DocuTech 128/155/180 HLC for

the curl in the paper, refer to the “Routine maintenance” and “Problem solving” sections of this guide.

Stock satisfaction guides

Table 5-1. Satisfaction guide for paper trays 1 and 2

Stock	Reliable feeds may be expected	Less reliable feeds may be expected	Suggested alternatives
Size	8 x 10 inches to 9 x 14 inches (203 x 254 mm to 229 x 356 mm)		Stock smaller than 8 x 10 inches cannot be used. For stock larger than 9 x 14 inches (229 x 356 mm), refer to the tray 3 satisfaction guide.
Weight	Substance 20 to 110 (75 to 200 g/m ²)	Substance 16 to 19 (60 to 72 g/m ²)	Weights outside the limits shown are not recommended. Substance 110 (200 g/m ²) must be long grain. Do not use short grain.
Capacity	Tray 1 - 1100 sheets, substance 20 (75 g/m ²) Tray 2 - 600 sheets, substance 20 (75 g/m ²)		For greater capacity, use tray 3.
Type or condition	Xerographic bond paper in good condition Drilled stock, fanned thoroughly Tab stock in perfectly flat condition	Slightly curled paper intermixed weight Transparencies Label stock Adhesive drafting film Paper with reinforced edges	Do not use excessively curled paper. Substance 110 (200 g/m ²) must be long grain Do not use short grain. Use transparencies with a white stripe. Freshly printed offset prints, use tray 3. Refer to the “Using various stocks” section for any stock not defined in this guide.

Table 5-2. Satisfaction guide for paper tray 4 Interposer ONLY

NOTE: *Production publisher configuration only*



Stock	Reliable feeds may be expected	Less reliable feeds may be expected	Suggested alternatives
Size	8 x 10 inches to 17 x 11 inches (203 x 254 mm to 432 x 279 mm)		Smaller or larger sizes cannot be used.

Stock	Reliable feeds may be expected	Less reliable feeds may be expected	Suggested alternatives
Weight	Substance 16 to 110 (60 to 200 g/m ²)		Weights outside the limits shown are not recommended. Substance 110 (200 g/m ²) must be long grain except 17 x 11 inch (432 x 279 mm) substance 110 (200 g/m ²) which must be short grain.
Capacity	550 sheets, substance 20 (75 g/m ²)		
Type or condition	Xerographic bond paper in good condition Drilled stock, fanned thoroughly	Slightly curled paper Intermixed weights Xerox vellum Full cut tabs Label stock Adhesive drafting film Paper with reinforced edges	Do not use excessively curled paper Substance 110 (200 g/m ²) must be long grain. Do not use short grain. Refer to the "Using various stocks" section for any stock not defined in this guide.

Table 5-3. Satisfaction guide for paper trays 3, 4, 5, and 6



NOTE: *High volume printer configuration only*

Stock	Reliable feeds may be expected	Less reliable feeds may be expected	Suggested alternatives
Size	8 x 10 inches to 17 x 11 inches (203 x 254 mm to 432 x 279 mm)		Smaller or larger sizes cannot be used.
Weight	Substance 16 to 110 (60 to 200 g/m ²)		Weights outside the limits shown are not recommended. Substance 110 (200 g/m ²) must be long grain except 17 x 11 inch (432 x 279 mm) substance 110 (200 g/m ²) which must be short grain.
Capacity	2600 sheets, substance 20 (75 g/m ²)		

Stock	Reliable feeds may be expected	Less reliable feeds may be expected	Suggested alternatives
Type or condition	Xerographic bond paper in good condition Drilled stock, fanned thoroughly	Slightly curled paper Intermixed weights Xerox vellum Full cut tabs Label stock Adhesive drafting film Paper with reinforced edges	Do not use excessively curled paper Substance 110 (200 g/m ²) must be long grain. Do not use short grain. Precut tabs - use tray 1 or 2. Transparencies with a white stripe, use tray 1 or 2. Freshly printed offset prints, use tray 3. Refer to the "Using various stocks" section for any stock not defined in this guide.

Table 5-4. Satisfaction guide for 2-sided printing

Stock	Reliable feeds may be expected	Less reliable feeds may be expected	Suggested alternatives
Size	8 x 10 inches to 17 x 11 inches (203 x 254 mm to 432 x 279 mm)		17 x 11 inch (432 x 279 mm) paper can only be sent to the top tray.
Weight	Substance 16 to 110 (60 to 200 g/m ²) Substance 110 (200 g/m ²) must be long grain.		Weights outside the limits shown are not recommended.
Type or condition	Xerographic bond paper in good condition Drilled stock, fanned thoroughly	Slightly curled paper Paper with reinforced edges	Do not use excessively curled paper. Refer to the "Using various stocks" section for any stock not defined in this guide.

Using various stocks

The following table lists stock that have been evaluated and tested for use in this system. There are many other stocks available, some of which may not provide the same degree of user satisfaction. Refer to the "Using non-standard stock" section in this guide

Table 5-5. Satisfaction guide for various stocks

Stock Type	Instructions for use
Substance 13 (49 g/m ²) paper	Use trays 3,4,or 5. Do not run 2-sided prints. Load the paper with seam side down into tray 3. Optimum satisfaction can be expected with 8.5 x 11 inch (216 x 279 mm) or larger paper.
Substance 16 (60 g/ m ²) paper	Load paper with seam side up into trays 1 and 2; seam side down into tray 3, 4, or 5. Optimum satisfaction can be expected from tray 3, 4, or 5.
Substance 20 (75 g/ m ²) paper	Load the paper with seam side up into trays 1 and 2; seam side down into trays 3, 4, and 5.
Card stock Xerox substance 65 (176 g/m ²) Substance 110 (200 g/ m ²) long grain (index)	Card stock can be run from any tray. Reduce set size if frequent paper jams or bindexer jams occur. If collated unfinished, another solution is to lower the value of the bindexer capacity set in the SWITCHES mode.
Xerox 4024, substance 20 (75 g/m ²) 3 hole drilled 4 hole drilled 7 hole drilled	Load the paper into trays 1 and 2 with holes to the right; load the paper into trays 3, 4, and 5 with holes to the left. Use the Image Shift or Reduce/Enlarge options to avoid printing near the holes. Fan the paper and check the paper for loose paper plugs before loading the paper into the trays.
Never-tear, 3 hole drilled	Load the paper into trays 1 and 2 with holes to the right; load the paper into trays 3, 4, and 5 with holes to the left. Do not bind or run 2-sided prints.
Never-tear	Do not bind or run 2-sided prints.

Stock Type	Instructions for use
3 hole drilled, edge reinforced, 4024 DP paper	<p>Do not stitch or bind. Do not run with tabs. Tabs can be inserted off-line.</p> <p>For optimum satisfaction, use the paper trays 1 and 2 plate assembly. The plate assembly can be ordered by a Customer Service Representative. Up to 500 sheets can be placed in the tray.</p> <p>Load the paper into all trays with holes to the left, reinforced side down.</p> <p>Select <Properties...> on the Trays pull-down menu. On the Stock window, under Type, select <Drilled>.</p> <p>Image quality problems may occur near the reinforcement with side 2 printing.</p> <p>Remove the paper immediately before use to ensure that prints stay flat.</p> <p>Print with no more than 200 sheets in a tray. Select a quantity of 50 or fewer at a time.</p>
Transparencies with a 0.5 inch (13 mm) white stripe	<p>Load the stock with the white stripe to the right into trays 1 and 2.</p> <p>Load the shiny side up for optimum performance.</p>
Removable stripe transparencies	<p>Do not load more than 50 removable-stripe transparencies into trays 1 and 2.</p> <p>With the white stripe to the right, place the transparencies on top of approximately 50 sheets of paper in the tray.</p> <p>Do not run as inserts to a bound job. Printing is not allowed on inserts.</p>
Tabs	<p>Mylar tabs should be run out of tray 4.</p>
Preprinted stock	<p>Preprinted forms must be made up of ink that has the following characteristics:</p> <ul style="list-style-type: none"> Can withstand temperatures up to 400°F (204°C) Can withstand pressure of 140 psi at the above temperature Can withstand the above conditions for 25 milliseconds
High speed transparencies with white stripe	<p>Load the stock with the stripe to the right in trays 1 and 2.</p>
Label stock	<p>Load the stock face up into trays 1 and 2; face down into trays 3, 4, and 5.</p> <p>Do not select 2-sided prints.</p>
Letterhead (preprinted)	<p>Load the paper into trays 3, 4, and 5; side 1 with the printed side down, top edge to the front of the tray.</p> <p>Load the paper into trays 1 and 2; side 1 up with the top edge to the front of the tray.</p> <p>Do not use freshly preprinted paper in trays 1 and 2.</p>

Stock Type	Instructions for use
Textured paper	Heavily textured paper may produce prints with a ragged character appearance or deletions. To test, run a proof print.
Window stock	Run if the window is 2.2 to 4 inches (57 to 102 mm) from the top edge of the paper and at least 1 inch (25.4 mm) from each side of the paper. Run only as the first page or a front cover to avoid finisher bin jams. Load the window stock face-up into a tray (tray 1 or 2 is recommended) with the top edge toward the front of the tray. If running plastic-covered window stock, there may be some distortion. To test, run a proof copy.
Xerox Carbonless	Xerox Carbonless Paper is recommended.

Do not use the following stocks:

- Multipart forms
- Stocks outside of the recommended size and weight ranges

Using non-standard stock

Using stock of non-standard width or length in the printer may have a negative impact on system performance. Refer to the following table for a listing of sizes and possible resulting impacts.

Table 5-6. Stock width impact on system performance

Stock width	Impact on performance
8.67 to 9 inches (221 to 229 mm) in trays 1, 2, 3, 4, and 5	Extended runs may increase the risk of temporary background. Increased risk of lead-edge image deletions on each successive sheet. Stock programming errors may go undetected because stock width checking is not performed.
9 inches (229 mm) to less than 14.2 inches (361 mm) in trays 3, 4, and 5.	Image offset may occur following a printer malfunction; for example, fuser jams. Running stock wider than 9 inches (229 mm) (other than 17 x 11 inches or A3) may increase the risk of misregistration, skew, and tray 3 elevator problems.

Table 5-7. Stock length impact on system performance

Stock length	Impact on performance
Over 11 inches (279 mm) to less than 11.7 inches (297 mm) Over 11.7 inches (279 mm) to less than 13 inches (330 mm) Over 13 inches (330 mm) to less than 14 inches (356 mm) Over 14 inches (356 mm)	The transfer assist mechanism is preset to optimize image transfer for the exact stock lengths of 11 inches (279 mm), 11.7 inches (297 mm), 13 inches (330 mm), and 14 inches (356 mm). Stock lengths falling between these exact lengths present an increased risk for bottom-edge deletions.
14.33 inches (B4 JIS)	Background, smudging, or white spaces may occur when printing between the 14 inch area and the edge of the paper.
10 inches (254 mm) to less than 11 inches (279 mm)	Because the 11 inch transfer mechanism is used for all stock lengths less than 11 inches (279 mm), there is an increased risk of contaminating the back side of sheets after switching back to longer stock.
11.2 inches (284 mm) to less than 11.5 inches (292 mm) 11.9 inches (302 mm) to less than 12.2 inches (310 mm) 13.5 inches (343 mm) to less than 13.7 inches (348 mm)	Unresolved stock size mismatch conflict messages may occur for stock lengths in these ranges. Job and stock programming work-arounds may be required.

Paper stock rotation

This section identifies the limitations on the rotation of paper stock in the DocuTech 128/155/180 HLC Bypass Transport when using a third-party finishing device.

Background

Due to the physical limitations of the DocuTech 128/155/180 HLC Bypass Transport, some paper stocks will be damaged or will jam while being rotated. Currently, when using an external finishing device that is not a Signature Booklet Maker, there is no message

displayed on the DocuSP controller to warn the Print Services Operator that the paper stock to be rotated will not fit in the Bypass Transport.

The Signature Booklet Maker attached to a DocuTech 128/155/180 HLC printer is only capable of handling paper stock up to 9 inches (229 mm) in length in a portrait orientation.

With the introduction of other DFA-complaint finishing devices for use with the DocuTech 128/155/180 HLC family of printers, additional paper stock sizes can be handled by the finishing devices, both straight from the Bypass Transport or rotated.

Limitations

Do not rotate paper sizes that will not fit through the DocuTech 128/155/180 HLC Bypass Transport to a third party finishing device.

Before creating a document to be rotated by the Bypass Transport, set the paper stock size required to fit within the limitations detailed in the following tables and as follows:

- The diagonal dimension of the paper stock must be equal to or less than 18 inches (457 mm).
- The paper stock must be within the paper stock size parameters of the DocuTech 128/155/180 HLC printer paper trays.

Refer to the DocuSP controller on-line help system for information on setting finisher devices and finisher profiles to enable rotation to a third party finisher.

Table 5-8. Common US paper sizes

Common size name	Inches x inches	Millimeter equivalent	Diagonal in inches	Can be rotated	Comment (similar to or the same as)
	8.0 x 10.75	203 x 273	13.40	YES	
US Letter/ US A-size	8.5 x 11.0	216 x 279	13.90	YES	2-up of US 5.5 x 8.5 in. (statement)
	9.0 x 12.0	229 x 305	15.00	YES	2-up of US 6.0 x 9.0 in. (common "book" size)
US Legal	8.5 x 14.0	216 x 356	16.38	YES	ISO Foolscap
	9.0 x 14.0	229 x 356	16.64	YES	2-up of US 7.0 x 9.0 in.
	9.0 x 15.0	229 x 381	17.49	NO*	2-up of US 7.5 x 9.0 in.

Common size name	Inches x inches	Millimeter equivalent	Diagonal in inches	Can be rotated	Comment (similar to or the same as)
	10.5 x 14.5	267 x 368	17.90	NO*	2-up of US 7.25 X 10.5 in. (Executive)
US Ledger/ US B-Size	11.0 x 17.0	279 x 432	20.25	NO	2-up of US 8.5 x 11.0 in. (Letter)

*Although the diagonal meets the 18-inch (457 mm) rotation limit, the paper stock long dimension exceeds the processor path width. The sheet must stay in the short-edge feed orientation throughout the paper path.



NOTE: *Non-United States customers: The part numbers in this table are for the United States only. Contact your local representative for common sizes used in Europe, Japan, Canada, etc.*

Table 5-9. Other paper sizes that can be rotated

Common size name	Inches x inches	Millimeter equivalent	Diagonal in inches	Can be rotated	Comment (similar to or the same as)
Largest square	12.73 x 12.73	323 x 323	18.00	YES	
Largest rectangle	10.89 x 14.33	277 x 364	18.00	YES	Length is constrained by paper path width.

For media sizes that are not listed in the above tables, view the graph shown in figure 5-1. The graph can be used to determine which sizes of media can and cannot be rotated within the Bypass Transport.

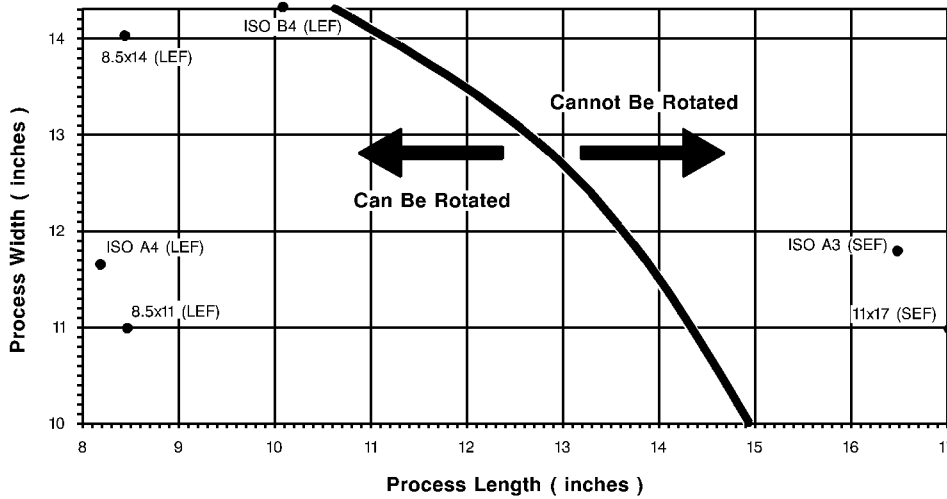

T305000A-C01

Figure 5-1. Rotatable and non-rotatable sizes (“as loaded” media size)

Sizes whose dimensions are located on the left of the curve or on the line itself have a diagonal that is less than or equal to 18.0 inches (457 mm) and therefore can be rotated. Those sizes whose dimensions are located to the right of the curve have diagonals greater than 18.0 inches (457 mm) and therefore cannot be rotated. Some common ISO sizes and US sizes are shown on the graph as examples.

Finisher satisfaction guides



NOTE: *Production publisher configuration only*

The following guides summarize the stacker, stitcher, binder, and top tray capabilities.

Table 5-10. Stacker capacity

Stock	Reliable stacking may be expected	Less reliable stacking may be expected	Suggested alternatives
Size	8 x 10 inches to 9 x 14 inches (203 x 254 mm to 229 x 356 mm)		Use the top tray for larger sizes
Weight	Substance 16 to 20 (60 to 75 g/m ²)		Weights outside the limits shown are not recommended.

Stock	Reliable stacking may be expected	Less reliable stacking may be expected	Suggested alternatives
Set or stack size	Substance 16 to 20 (60 to 75 g/m ²)	Over substance 20 (75 g/m ²) stock as sets or stacks increases the likelihood of bindexer jams.	When using copy paper heavier than substance 20 (75 g/m ²), limit the stack or set size by dividing the set into parts. Combine prints when completed and finish offline, if required. For collated unfinished sets, the maximum sheet capacity of the bindexer can be set to between 50 and 125.
Stacker capacity	Unfinished sheets: 3300 sheets, substance 16 (60 g/m ²) 3000 sheets, substance 20 (75 g/m ²) 2500 sheets, substance 24 (90 g/m ²) 1875 sheets, substance 32 (120 g/m ²) 1360 sheets, substance 110 (200 g/m ²)		To allow a continuous run, unload outer stack before inner stack reaches capacity.
Type or condition	Xerographic bond paper in good condition Drilled paper	Slightly curled paper	Do not use excessively curled paper. Transparencies must contain some opaque sheets to avoid finisher jams. Stock not defined here is included in the "Using various stocks" section in this guide.

Table 5-11. Stitcher satisfaction guide

Stock	Reliable stacking may be expected	Less reliable stacking may be expected	Suggested alternatives
Size	8 x 10 inches to 9 x 14 inches (203 x 254 mm to 229 x 356 mm)		Use the top tray for larger sizes
Weight	Substance 16 to 110 (60 to 200 g/m ²)		Weights outside the limits shown are not recommended.
Set size limit due to copy paper weight	Collated: Up to 65 sheets of substance 20 (75 g/m ²) or 0.28 inch (7 mm) thick sets Uncollated: 50 copies maximum per stitch 0.28 inch (7 mm) thick sets	Collated: Up to 70 sheets of substance 20 (75 g/m ²)	Reduce the paper weight to enable stitching more sheets per collated set. Check the stitch quality.
Stacker capacity	Stacker capacity adjusts automatically to suit various set sizes		To allow a continuous run, unload outer stack before inner stack reaches capacity.

Table 5-11. Stitcher satisfaction guide

Stock	Reliable stacking may be expected	Less reliable stacking may be expected	Suggested alternatives
Type or condition	Xerographic bond paper in good condition Drilled paper	Slightly curled paper	Do not use excessively curled paper. Transparencies must contain some opaque sheets to avoid finisher jams. Stock not defined here is included in the "Using various stocks" section in this guide.

Table 5-12. Binder satisfaction guide

Stock	Reliable stacking may be expected	Less reliable stacking may be expected	Suggested alternatives
Size	8 x 10 inches to 9 x 14 inches (203 x 254 mm to 229 x 356 mm)		Consider stitching for smaller or larger sizes.
Weight: Main Body	Substance 20 to 24 (75 to 90 g/m ²)	Substance 16 (60 g/m ²) Without covers	Avoid weights less than substance 16 (60 g/m ²) or greater than substance 24 (90 g/m ²) Consider stitching for weights outside these limits.
Weight: Covers	Maximum: substance 65 (176 g/m ²)	Heavier than substance 65 (176 g/m ²) Transparencies	Avoid removable stripe transparencies
Weight: Insert	Maximum: substance 65 (176 g/m ²) Minimum: substance 20 (75 g/m ²)	Heavier than substance 65 (176 g/m ²) Lighter than substance 20 (75 g/m ²)	Limit the inserts outside of substance 16 to 24 (60 to 90 g/m ²) to 10% of the sheet count in a set. Avoid adjacent inserts for substance greater than 24 (90 g/m ²). Transparencies or never-tear paper cannot be used as inserts when binding.

Table 5-12. Binder satisfaction guide

Stock	Reliable stacking may be expected	Less reliable stacking may be expected	Suggested alternatives
Set size limits	<p>Maximum collated: 125 sheets of substance 20 (75 g/m²) or equivalent thickness</p> <p>Minimum collated: 15 sheets of substance 20 (75 g/m²) (7 sheets with index covers) or equivalent thickness</p> <p>Maximum uncollated: 100 sheets of substance 20 (75 g/m²)</p> <p>Minimum uncollated: 15 sheets of substance 20 (75 g/m²) (7 sheets with index covers) or equivalent thickness</p>	125 sheets of substance 16 (60 g/m ²)	<p>Consider stitching for set sizes smaller than 15 sheets (or equivalent thickness). Reduce the number of sheets to maintain a maximum set thickness of 0.5 inch (13 mm) when using heavier than substance 20 (75 g/m²) for main body or inserts.</p>
Stacker capacity	Delivers 12 sets inboard and 12 sets outboard		To allow continuous run, unload outer stack before inner stack reaches capacity.
Type or condition	<p>Xerographic bond paper in good condition</p> <p>Drilled paper</p>	Slightly curled paper	<p>Avoid the following:</p> <ul style="list-style-type: none"> Coated papers Drilled stock with reinforced edges Transparencies as inserts Excessively curled paper Never-tear paper <p>Stock not defined here is included in the "Using various stocks" section in this guide.</p>

Table 5-13. Top tray satisfaction guide

Stock	Reliable stacking may be expected	Less reliable stacking may be expected	Suggested alternatives
Size	8 x 10 inches to 11 x 17 inches (203 x 254 mm to 279 x 432 mm)	Intermixed sizes	Smaller or larger sizes cannot be used.
Weights	<p>Substance 16 to 110 (60 to 200 g/m²)</p> <p>Weights cannot be intermixed</p>	Substance 16 (60 g/m ²) over 9 x 14 inches (229 x 356 mm) may yield stacking registration problems.	Weights outside the limits shown are not recommended.
Capacity	<p>500 sheets, substance 20 (75 g/m²) or less</p> <p>415 sheets, substance 24 (90 g/m²)</p> <p>310 sheets, substance 32 (120 g/m²)</p> <p>225 sheets, substance 110 (200 g/m²)</p>		If using a paper heavier than substance 20 (75 g/m ²), unload the tray before the count in the tray reaches 500. Check the stitch quality.

Table 5-13. Top tray satisfaction guide

Stock	Reliable stacking may be expected	Less reliable stacking may be expected	Suggested alternatives
Type or condition	Xerographic bond paper in good condition Drilled paper	These may yield stacking registration problems: Slightly curled paper Precut tabs cannot be sent to the top tray.	Do not use excessively curled paper. Stock not defined here is included in the "Using various stocks" section in this guide.

6 Service and supplies

After the installation of your printer, there are a few ongoing tasks that must be performed. These tasks may include all or some of the following:

- Maintaining an adequate inventory of consumable supplies
- Overseeing routine maintenance and meter reporting
- Arranging additional operator training
- Printing additional documentation
- Placing service calls for hardware problems

As the installation coordinator, it is your responsibility to designate a person or persons to perform these tasks. This chapter describes these tasks and some of the support services available to customers. There is also a description of commonly used consumable supplies and a supplies checklist.

Xerox support services

Many services are provided in support of your printer. This section contains information on the following services:

- Customer Support Center
- Customer Education
- Supplies Order Service

Prior to installation, your sales representative is available to answer your questions about products, services, or billing. However, if you need assistance in resolving application-related problems or questions, call Customer Support (refer to the following section of this chapter). Your systems analyst is also available to assist you with applications development.

Customer support

The customer support center is available to address your application problems or to direct you to the appropriate documentation.

The key to effective use of the support center is correct identification of the problem. Before calling the support center, it is helpful to have the following information available:

- A list of any error messages
- An explanation of how output is different from what you expected
- An assessment of whether the symptoms follow a pattern or occur randomly
- A list of special conditions that may have caused the problem:
 - New applications
 - Changes made to the software
 - Recent service performed
 - Previous conditions under which the application has printed properly

To contact the U.S. Xerox Customer Support Center, call 1-800-821-2797. The Xerox Customer Support Center provides 24 hour support.

Operator training

Operator training is conducted either at your location or at a Xerox Customer Education Center shortly after the printer is installed. The training includes hands-on practice running basic jobs, performing routine maintenance, and solving problems. Determine the number of operators you want to attend the initial training and schedule training dates and times through your sales representative.

Supplies service

To avoid downtime, always have an adequate amount of the necessary supplies. To do this, you need to establish a procedure for checking and ordering supplies. A supplies checklist is provided at the end of this chapter to help you with this task. It lists the supplies needed for the printer and contains a column for you to enter the date when you want to place the order and a column to record the date of the actual order. The consumable supplies table, also located at the end of this chapter, contains a list of supplies available for the printer.

It is important that you check your supplies regularly and order before you run out. Plan on approximately five working days for the delivery after placing the order. You can make arrangements to receive them sooner in emergency situations.

Your sales representative can help you submit the initial order of supplies needed for installation. These items include paper, dry ink, fuser blend, and developer.

Once your printer volume is established, planning ahead and buying Xerox supplies in quantity can save you money. Your supply specialists can help you.



NOTE: *The supplies resources listed below are for the United States only. Multinational customers should contact their local representatives for supplies ordering information.*

There are two centers available to assist you:

- To order Xerox paper, transparencies, labels, dry ink, developer, fuser blend, and diskettes, call the Xerox Supply Center weekdays between 7:30 a.m. and 6:00 p.m., Pacific Standard time.

If you prefer, you may mail orders to the following address:

Xerox Corporation
P.O. Box 25075
Santa Ana, CA 92799-5075

- To order cleaning supplies, call the Xerox Customer Parts and Product Support Center weekdays between 5:30 a.m. and 5:00 p.m., Eastern Standard time, at 1-800-828-5881 (U.S. only).

You may also mail cleaning supplies orders to the following address:

Xerox Corporation
Parts Marketing Center Building 214-07S
P.O. Box 1020
Webster NY 14580

Please provide the following information when placing orders:

- Your customer number (provided by your sales representative)
- Your printer model
- Your supply order, including the following information: –
 - Item name
 - Part number
 - Quantity desired
 - If your company requires a purchase order for payment of an invoice, you need to provide the purchase order number to Xerox at the time you place the order.

Routine maintenance

There are a number of routine maintenance tasks that must be performed to ensure maximum efficiency of your printer. These tasks include the following:

- Adding dry ink
- Cleaning the exterior surfaces of the system

Step-by-step instructions on performing these routine maintenance tasks are contained in your DocuTech 128/155/180 Operator Guide.

You need to decide how many operators will be responsible for performing these maintenance tasks. Most maintenance procedures are covered in the initial operator training provided shortly after installation.

Meter reading and reporting

As print jobs are processed, the DocuSP controller accumulates, saves, and maintains usage data. During the last five working days of each month, you need to review and transmit the data to Xerox for billing purposes. Refer to the section on Billing in the Help on the DocuSP controller for complete information on how to view and print the billing meter readings.

Consumable supplies table

The following table lists the supplies that are available from Xerox for your printer. Use this table to help you determine your printer needs.

The following symbols are used in the table:

* 5/16-inch drilled holes

** Rainbow pack contains 750 sheets each of blue and yellow, 500 sheets each of green and pink, and 250 sheets each of buff, gray, goldenrod, and ivory.



NOTE: *Non-United States customers: The part numbers in this table are for the United States only. Contact your local representative for supplies ordering information.*



CAUTION: *Do not use any supplies not approved by Xerox. You can damage the system by using supplies other than those recommended.*

Table 6-1. Consumable supplies

Item	Description	U.S. part number
Paper	Xerox paper quantities are 10 reams (5,000 sheets) to a carton unless otherwise noted below	
8.5 x 11 inch	Xerox Business 4200	3R2047
A4	Xerox Business 4200	3R2594
8.5 x 14 inch	Xerox Business 4200	3R2051
8.5 x 11 inch	Xerox Business 4200, 3-hole*	3R2641
8.5 x 17 inch	Xerox Business 4200	3R3761
8.5 x 11 inch	Xerox Business 4200, 4-hole*	3R3008
8.5 x 11 inch	Xerox Business 4200, 7-hole*	3R3010
8.5 x 11 inch	4200 Smooth	3R2675
8.5 x 14 inch	4200 Smooth	3R2677
8.5 x 11 inch	Dual Purpose Colors, Blue	3R3052
8.5 x 11 inch	Dual Purpose Colors, Blue, 3-hole	3R3068
8.5 x 14 inch	Dual Purpose Colors, Blue	3R3084
8.5 x 11 inch	Dual Purpose Colors, Green	3R3056
8.5 x 11 inch	Dual Purpose Colors, Green, 3-hole	3R3072
8.5 x 14 inch	Dual Purpose Colors, Green	3R3088
8.5 x 11 inch	Dual Purpose Colors, Pink	3R3058
8.5 x 11 inch	Dual Purpose Colors, Pink, 3-hole	3R3074
8.5 x 14 inch	Dual Purpose Colors, Pink	3R3090
8.5 x 11 inch	Dual Purpose Colors, Yellow	3R3054
8.5 x 11 inch	Dual Purpose Colors, Yellow, 3-hole	3R3070
8.5 x 14 inch	Dual Purpose Colors, Yellow 3	R3086
8.5 x 11 inch	Dual Purpose Colors, Buff	3R3060
8.5 x 11 inch	Dual Purpose Colors, Buff, 3-hole	3R3076
8.5 x 14 inch	Dual Purpose Colors, Buff	3R3092
8.5 x 11 inch	Dual Purpose Colors, Goldenrod	3R3062
8.5 x 11 inch	Dual Purpose Colors, Goldenrod, 3-hole	3R3078
8.5 x 14 inch	Dual Purpose Colors, Goldenrod	3R3094
8.5 x 11 inch	Dual Purpose Colors, Ivory	3R3064
8.5 x 11 inch	Dual Purpose Colors, Ivory, 3-hole	3R3080

Item	Description	U.S. part number
8.5 x 14 inch	Dual Purpose Colors, Ivory	3R3096
8.5 x 11 inch	Dual Purpose Colors, Gray	3R3066
8.5 x 11 inch	Dual Purpose Colors, Gray, 3-hole	3R3802
8.5 x 14 inch	Dual Purpose Colors, Gray	3R3098
8.5 x 11 inch**	Dual Purpose Colors, Rainbow Pack 35,000 sheets/carton - 250 sheets/pack**	3R3107
8.5 x 11 inch	10 Series Dual Purpose Paper	3R2950
8.5 x 11 inch	10 Series Dual Purpose Paper, 3-hole	3R2952
8.5 x 11 inch	10 Series Dual Purpose Paper, 3-hole*	3R3016
8.5 x 14 inch	10 Series Dual Purpose Paper	3R2954
8.5 x 11 inch	10 Series Smooth	3R54
8.5 x 14 inch	10 Series Smooth	3R83
8.5 x 11 inch	4200 Dual Purpose, reinforced 3-hole	3R2057
Image LX (Laser Xerographic Paper)	White 8.5 x 11 inch (5000 sheets/carton)	3R3874
Image LX	White 8.5 x 11 inch 3-hole (5000 sheets/carton)	3R3875
Image LX	White 8.5 x 14 inch (4000 sheets/carton)	3R3876
Image LX	White 11 x 17 inch (4000 sheets/carton)	3R3877
Transparencies	Xerox transparencies are packaged 100 sheets to a box	
8.5 x 11 inch	Clear, with a white strip on the edge	3R2780
Labels (Gummed)	Xerox labels are packaged 100 sheets to a box	
8.5 x 11 inch	33 labels per sheet	3R3139
8.5 x 11 inch	6 labels per sheet	3R3146
8.5 x 11 inch	Custom form (uncut)	Contact Xerox Supplies Order Service

Item	Description	U.S. part number
Dry Ink Black	Packaged 3 cartridges per carton. 220K/carton with 6% black only area coverage	6R206 (US/CA)
Dry Ink Blue	300K/Carton with 1.5% area coverage as highlight color	6R1191 (US/CA) 6R90343 (EU)
Dry Ink Red	300K/Carton with 1.5% area coverage as highlight color	6R1192 (US/CA) 6R90344 (EU)
Dry Ink Green	300K/Carton with 1.5% area coverage as highlight color	6R1193 (US/CA) 6R90345 (EU)
Dry Ink Royal Blue	300K/Carton with 1.5% area coverage as highlight color	6R1255 (US/CA) 6R90356 (EU)
Dry Ink Cardinal Red	300K/Carton with 1.5% area coverage as highlight color	6R1277 (US/CA) 6R90358 (EU)
Dry Ink Cyan	300K/Carton with 1.5% area coverage as highlight color	6R1284 (US/CA) 6R90359 (EU)
Dry Ink Waste Bottle	500K/bottle	93K1393
HLC Developer Waste Container	800K/bottle with 1.5% highlight color area coverage	604K24870 (4)
Black Developer	Packaged 2 bottles per carton. Developer effective life is dependent upon the number of charged images printed and the size of the stock. Xerox developer is guaranteed by Xerox for 500,000 pages of 8.5 x 11 inches (216 x 279 mm or A4) stock. Effective life is approximately one carton per 500,000 pages.	5R161 (US/CA) 5R90095 (EU)
Blue Developer	Packaged 2 bottles per carton. Effective life is approximately one carton per 500,000 pages.	5R688
Red Developer	Packaged 2 bottles per carton. Effective life is approximately one carton per 500,000 pages.	5R689
Green Developer	Packaged 2 bottles per carton. Effective life is approximately one carton per 500,000 pages.	5R690
Cardinal Red Developer	Packaged 2 bottles per carton. Effective life is approximately one carton per 500,000 pages.	5R717

Item	Description	U.S. part number
Royal Blue Developer	Packaged 2 bottles per carton. Effective life is approximately one carton per 500,000 pages.	5R715 5R716 (FX)
Cyan Developer	Packaged 2 bottles per carton. Effective life is approximately one carton per 500,000 pages.	5R719
Fuser shield*	Consumption rate is approximately one bottle per 200,000 pages.	8R4077 (1)
Fuser blend*	Consumption rate is approximately one bottle per 200,000 pages.	8R12938 (1) 8R12939 (6 bottles)
Cleaning supplies	Foam-tipped swabs	99P87256
	Lint-free towels	35P2163
Cartridge tape	4 mm blank cartridge, 8 GB	109R00314
Diskettes	3.5 inch, double sided, dual density, 1.44 MB, unformatted. Packaged 10 per box.	8R3704
Wire Modules	1 unit per package	802K26190 802K26191 in 8/04
Stitcher Wire	Packaged 1 reel per carton. Consumption rate is approximately 32,000 stitches per reel.	8R1174
Binder Tape	Black White Gray Blue Packaged 1 reel per carton. Consumption rate is approximately 425 binds per carton.	8R7186 8R7187 8R7188 8R7189



CAUTION: **Do not use DT/DP Fuser Agent 8R2955 in a DT HLC printer. Do not use DT HLC Fuser Blend in other DocuTech or DocuPrint systems.*



CAUTION: **Fuser blend and Fuser shield are NOT interchangeable. Contact your Xerox representative before switching from one to the other.*



NOTE: *Developer is ordered and stocked by the Xerox Service Representative for your site. The part numbers are provided here for informational purposes only.*

Use the following table to help record the supplies and accessories you require, the date on which the order should be placed, and the actual date of the order.

Table 6-2. Supplies checklist

Item	Description	Quantity	Date of order	Date ordered
Paper				
Dry ink				
Developer				
Fuser shield				
Labels				
Transparencies				
Cleaning supplies				
Other				

Item	Description	Quantity	Date of order	Date ordered

Free Manuals Download Website

<http://myh66.com>

<http://usermanuals.us>

<http://www.somanuals.com>

<http://www.4manuals.cc>

<http://www.manual-lib.com>

<http://www.404manual.com>

<http://www.luxmanual.com>

<http://aubethermostatmanual.com>

Golf course search by state

<http://golfingnear.com>

Email search by domain

<http://emailbydomain.com>

Auto manuals search

<http://auto.somanuals.com>

TV manuals search

<http://tv.somanuals.com>