

***The Xerox
DocuPrint N17 and
N17b Network Laser
Printers***

User Guide

Version 1.8

Copyright © 1998, 1999 Xerox Corporation. All Rights Reserved.

Copyright protection claimed includes all forms of matters of copyrightable materials and information now allowed by statutory or judicial law or hereinafter granted, including without limitation, material generated from the software programs which are displayed on the screen such as styles, templates, icons, screen displays, looks, etc.

XEROX®, The Document Company®, the stylized X, DocuPrint, and N17 are trademarks of Xerox Corporation or its subsidiaries.

Adobe® and PostScript® are trademarks of Adobe Systems Incorporated.

PCL, HP, and LaserJet are trademarks of Hewlett-Packard Company. IBM is a trademark of International Business Machines Corporation. Microsoft, Microsoft Windows, Microsoft Word, MS, and MS-DOS are trademarks of Microsoft Corporation. Univers is a trademark of Linotype AG or its subsidiaries. WordPerfect is a trademark of Corel Corporation. Centronics is a trademark of Centronics Corporation. Macintosh and TrueType are trademarks of Apple Computer, Incorporated. OnPage is a trademark of COMPUTER:applications, Inc. All other product names are trademarks/tradenames of their respective owners.

PCL, *PCL 5e* and *PCL 6* are trademarks of Hewlett Packard Company. This printer contains an emulation of the Hewlett Packard PCL 5e and PCL 6 command languages, recognizes HP PCL 5e and PCL 6 commands, and processes these commands in a manner comparable with Hewlett Packard LaserJet printer products.

This product includes an implementation of LZW licensed under U.S. Patent 4.558.302.

Notice

Specifications described in this publication are subject to change without notice. Use of some features may be limited by your hardware or software configuration. Contact your dealer, Xerox, or Xerox Limited for details.

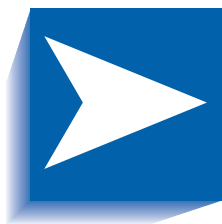
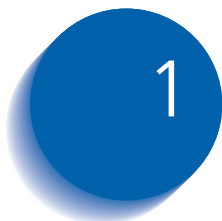

Table of Contents

Chapter 1	Getting Started	1-1
	<i>DocuPrint N17 and N17b Models</i>	<i>1-2</i>
	<i>User Documentation Roadmap</i>	<i>1-3</i>
	<i>Printed Documentation</i>	<i>1-3</i>
	<i>DocuPrint N17 Product CD</i>	<i>1-4</i>
	<i>Using the CDs</i>	<i>1-5</i>
	<i>How Much of This Book Must I Read?</i>	<i>1-6</i>
	<i>Printer Components</i>	<i>1-7</i>
	<i>Installing Your Printer</i>	<i>1-8</i>
	<i>Printing a Configuration Sheet</i>	<i>1-10</i>
Chapter 2	Printer Management Software and Drivers	2-1
	<i>Using CentreWare DP with the DocuPrint N17</i>	<i>2-2</i>
	<i>DocuPrint N17 PCL Printer Drivers</i>	<i>2-3</i>
	<i>DocuPrint N17 PostScript Printer Drivers</i>	<i>2-4</i>
	<i>Driver Features</i>	<i>2-5</i>
	<i>Installing CentreWare and Drivers</i>	<i>2-7</i>
	<i>Configuring Your Drivers</i>	<i>2-7</i>

Chapter 3	Using the Control Panel	3-1
	Control Panel Features.....	3-2
	<i>The Display</i>	<i>3-3</i>
	Menu Options.....	3-4
Chapter 4	Paper Loading and Orientation	4-1
	Selecting Paper.....	4-2
	Storing Paper.....	4-5
	Loading Paper.....	4-6
	<i>Using Tray 1.....</i>	<i>4-6</i>
	<i>Using the MBF.....</i>	<i>4-9</i>
	<i>Using the 500-sheet Paper Deck and Cassette.....</i>	<i>4-14</i>
	<i>Using the High Capacity Feeder.....</i>	<i>4-17</i>
	<i>Using the Envelope Feeder.....</i>	<i>4-20</i>
	Automatic Tray Switching.....	4-22
	<i>Paper Size/Type Mismatch.....</i>	<i>4-23</i>
	Duplex (Two-Sided) Printing.....	4-24
	<i>Print Orientation and Control Panel Settings.....</i>	<i>4-25</i>
Chapter 5	Clearing Jams and Jam Recovery	5-1
	Paper Jams.....	5-2
	<i>What Causes a Paper Jam?</i>	<i>5-2</i>
	Clearing Paper Jams.....	5-3
	<i>Tray 1 Jam</i>	<i>5-7</i>
	<i>MBF Jam.....</i>	<i>5-8</i>
	<i>Tray 2 Jam with 500-sheet Paper Deck and Cassette</i>	<i>5-9</i>
	<i>Tray 3 Jam with 500-sheet Paper Deck and Cassette</i>	<i>5-10</i>
	<i>Tray 2 or Tray 3 Jam with 2,000-sheet HCF</i>	<i>5-11</i>
	<i>Envelope Feeder Jam.....</i>	<i>5-12</i>
	<i>OCT Jam.....</i>	<i>5-13</i>
	<i>Duplex Module Jam.....</i>	<i>5-14</i>
	<i>Paper Exit Jam.....</i>	<i>5-15</i>
	<i>EP Cartridge Jam.....</i>	<i>5-16</i>

	<i>Paper Mismatch Jam</i>	5-17
	<i>Misfeed Jam at Startup</i>	5-18
	<i>Fuser Jam</i>	5-19
Chapter 6	<i>Replacing Consumables</i>	6-1
	<i>Replacing the EP Cartridge</i>	6-2
	<i>Replacing the Fuser Cartridge/BTR</i>	6-5
Chapter 7	<i>Troubleshooting</i>	7-1
	<i>Diagnostic Message Display</i>	7-2
	<i>Printer Operation Problems</i>	7-3
Chapter 8	<i>References</i>	8-1
	<i>Further References</i>	8-2
Appendix A	<i>CE Declaration</i>	A-1



Getting Started

<i>DocuPrint N17 and N17b Models</i>	1-2
<i>User Documentation Roadmap</i>	1-3
<i>How Much of This Book Must I Read?</i>	1-6
<i>Printer Components</i>	1-7
<i>Installing Your Printer</i>	1-8
<i>Printing a Configuration Sheet</i>	1-10

DocuPrint N17 and N17b Models

This book is for use with both the Xerox DocuPrint N17 and DocuPrint N17b Network Laser Printers. The DocuPrint N17 contains all the components of the DocuPrint N17b, plus the following:

- Ethernet 10Base2 and 10BaseT
- Audible buzzer

As this guide serves both printers, the DocuPrint N17b will hereafter be referred to as the DocuPrint N17 except in situations where information is specific to either printer.

User Documentation Roadmap

Your DocuPrint N17 printer is packaged with documentation in both printed form and on CD. There are two CDs:

- **Product CD**, which contains documentation and printer drivers.
- **Printer Management Software CD**, which contains various Xerox-provided client software and the documentation for it.

This section serves as a roadmap for the printed and CD documentation

Printed Documentation

Your DocuPrint N17 printer was packaged with the following pieces of printed documentation:

- **Quick Install Guide**, which shows you how to get your printer up and running.
- **User Guide** (this book), which provides you with the basic information needed to use your printer. (More detailed user information is contained in the *System Administrator Guide* on your Product CD.)
- **Quick Network Install Guide**, which briefly shows you how to connect your printer to a network in your specific environment. (More detailed Network/Environment information is contained in the *Technical Information Guide* on your Product CD.)

DocuPrint N17 Product CD

Your DocuPrint N17 printer was also packaged with a CD that contains the following pieces of information:

- **User Guide** (electronic version of this book)
- **Quick Network Install Guide**
- **System Administrator Guide**
- **Technical Information Guide**
- A procedure to upgrade your printer software

The System Administrator Guide contains the following information should you require it:

- Printer installation instructions, in Chapter 1.
- Installation instructions for all DocuPrint N17 options, in Appendix C.
- Installation instructions for the EP cartridge and BTR replacement, in Appendix B.

The System Administrator Guide also contains a considerable amount of more detailed user information.



DocuPrint N17 printer drivers are also contained on the Product CD. The majority of driver documentation is provided via the Help files included with the drivers.

Since both the Product CD and the Printer Management Software CD contain so much important information, please ensure that you save them and keep them in a safe place.

Using the CDs

The documentation on the Product CD is provided as PDF files, which are opened in Adobe Acrobat Reader (provided on the CD if you do not already have it installed). These files contain hypertext links that enable you to jump from the Table of Contents or Index directly to the page where you are looking for information, as well as from page to page where information is cross-referenced. Simply move the cursor over a hypertext link and it changes to a pointing finger. Then click on the link to jump to the link's destination.

The PDF files also enable you to print the specific pages you need, rather than printing an entire chapter or manual.

Both the Product CD and the Printer Management CD are provided with installation booklets in their respective jewel cases. You can also refer to the ReadMe files on the CDs for more information.

How Much of This Book Must I Read?

Use this book as a reference for:

- Getting Started (*Chapter 1: Getting Started*)
- Information about CentreWare and installing printer drivers (*Chapter 2: Printer Management Software and Drivers*)
- Instructions on using the Control Panel (*Chapter 3: Using the Control Panel*)
- Paper specifications, loading paper, and duplex printing (*Chapter 4: Paper Loading and Orientation*)
- Clearing Jams(*Chapter 5: Clearing Jams and Jam Recovery*)
- Replacing Your Toner Cartridge and Fuser Cartridge/ BTR (*Chapter 6: Replacing Your Toner Cartridge*)
- Troubleshooting printing problems if they occur (*Chapter 7: Troubleshooting*)
- Further References (*Chapter 8: References*)

Printer Components

The major printer components are indicated below.

Figure 1.1 Major printer components

Front View

- 1 Control Panel Display
- 2 Control Panel Keypad
- 3 Recessed Grip
- 4 Power Switch
- 5 Standard Output Bin
- 6 Front Cover
- 7 Front Cover Release Button
- 8 MBF (Multi-bypass Tray)
- 9 MBF Release Point
- 10 Tray 1

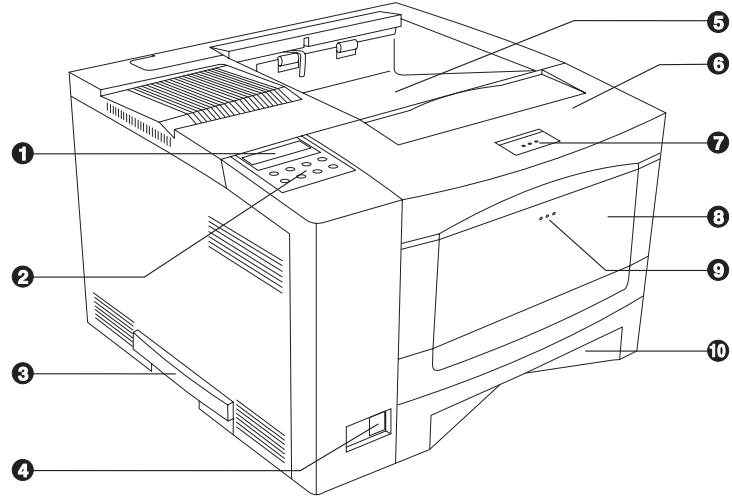

Rear View

- 1 Option Interface Cover
- 2 Rear Cover
- 3 Power Inlet
- 4 Ethernet Ports (N17 only)
- 5 Parallel Port
- 6 Serial Port
- 7 Diagnostic LED
- 8 Ethernet LED (N17 only)
- 9 Port for Optional Network Card

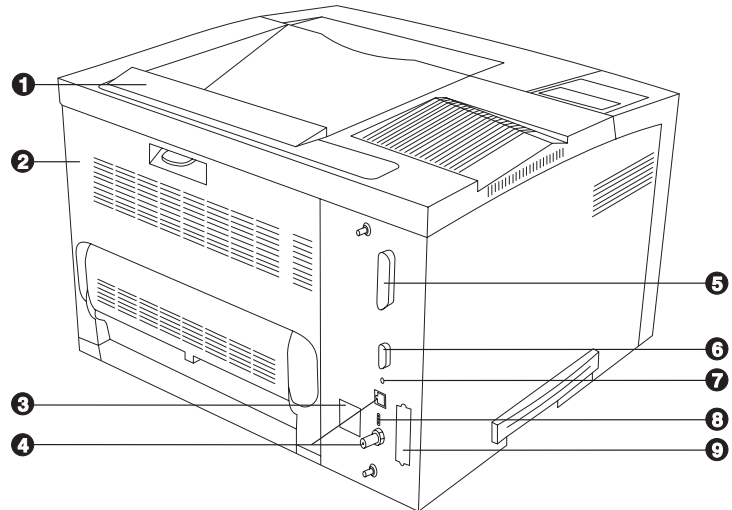

Installing Your Printer

There are other documents which will help you install your printer. The purpose of this section is simply to guide you to those documents (and sections of documents). The following documentation is available for installation assistance:

- The DocuPrint N17 System Administrator Guide (on the DocuPrint N17 Product CD)
 - Chapter 1 shows how to initially install the DocuPrint 17.
 - Appendix B shows how to replace the DocuPrint N17 EP Cartridge and BTR/Fuser.
 - Appendix C shows how to install (and remove) the 2,500 Sheet Feeder, Duplex Module, Envelope Feeder, Hard Disk Drive, XNIC Network Interfaces, and memory SIMMs.
- The 2,500 Sheet Feeder and Envelope Feeder have installation instructions in their boxes, while the other N17 options have wordless instructions *on* their boxes.
- The DocuPrint N17 itself comes with a Quick Start Card which guides you on your initial installation of the printer.
- The DocuPrint N17 Quick Network Install Guide provides guidance as to how to connect to the network within your specific environment.

- Chapter 2 of this guide provides some direction on how to install your DocuPrint N17 drivers and CentreWare software. More information is provided on the CD.
- More detailed information about installation can also be found in your CentreWare Users Manual, contained on the Printer Management Software CD that comes with your DocuPrint N17.



Please remember to save and store all your packing materials in a dry place so that you can retrieve these materials in the future should you be required to transport your DocuPrint N17 or its options.

Printing a Configuration Sheet

A very convenient way of both testing basic printer operation and determining how your printer is configured is to print a Configuration Sheet.

The following operator sequence from the DocuPrint N17 Control Panel will cause a Configuration Sheet to be printed:

1. Press **Menu Up** or **Menu Down** until you see:

Menus
Test Menu

on the Display.

2. Press **Item Up** or **Item Down** until you see:

Test Menu
Config Sheet

on the Display.

3. Press **Enter**. The Configuration Sheet will be printed.



2

Printer Management Software and Drivers

<i>Using CentreWare DP with the DocuPrint N17</i>	<i>2-2</i>
<i>DocuPrint N17 PCL Printer Drivers</i>	<i>2-3</i>
<i>DocuPrint N17 PostScript Printer Drivers</i>	<i>2-4</i>
<i>Driver Features</i>	<i>2-5</i>
<i>Installing CentreWare and Drivers</i>	<i>2-7</i>

Using CentreWare DP with the DocuPrint N17

Xerox CentreWare DP is easy-to-use printer management software for Xerox printers. Through the ease of point-and-click navigation, you can install, connect, and configure the DocuPrint N17 on a network, quickly and easily.

CentreWare DP provides network administrators with simplified setup procedures and effortless management of networked Xerox DocuPrint N17 printers.

Table 2.1 lists CentreWare DP key features and benefits. For more specific information about CentreWare DP use and operation, see “The CentreWare DP User Guide.”

Table 2.1 CentreWare DP key features and benefits

Feature	Benefit
Setup Wizard	Provides a step-by-step guide to get your printer quickly up and running on the network.
Advanced Setup	Provides a tool to service multiple file servers and queues.
Instant Status	Allows you to select a printer from the Printer List to see what that printer is doing at any given time.
Remote Configuration and Management	Allows you to do most configuration and monitoring tasks from your workstation.
Printer Upgrades	Allows you to upgrade your printer from your workstation.

CentreWare DP SunOS/Solaris Services are also available to allow you to set up queues, and contain your DocuPrint N17 drivers for SunOS/Solaris. All of the CentreWare DP software and documentation are on your Printer Management Software CD.

DocuPrint N17 PCL Printer Drivers

The DocuPrint N17 supports the PCL Emulation printer drivers listed in Table 2.2. To take full advantage of all the printer's features when printing PCL jobs, install the appropriate DocuPrint N17 PCL Emulation printer driver(s).

Table 2.2 DocuPrint N17 PCL printer drivers

Environment	Printer Driver
Windows	Windows 3.1x/ Windows 95 Windows NT 3.5.1 Windows NT 4.0

DocuPrint N17 PostScript Printer Drivers

The DocuPrint N17 supports the PostScript drivers listed in Table 2.3. To take full advantage of all the printer's features when printing PostScript jobs, install the appropriate DocuPrint N17 printer driver(s).

Table 2.3 DocuPrint N17 PostScript printer drivers

Environment	Printer Driver
Windows	Windows 3.1x/ Windows 95 Windows NT 3.5.1 Windows NT 4.0
IBM OS/2	OS/2 Ver. 2.1 OS/2 WARP
Macintosh	System 6.x System 7.x
UNIX	Sun OS 4.14, IBM AIX 4.1.x, 4.2.x, HP-UX 9.x, 10.x Sun Solaris 2.4, 2.5, 2.51, 2.6

Driver Features

DocuPrint N17 drivers will support the following standard features:

- Input tray/Output bin selection
- Duplex selection
- Paper size, orientation and media
- Number of copies
- Collating

Table 2.4 on page 2-6 lists a general overview of features supported by the DocuPrint N17 drivers. Actual driver capabilities can be determined by invoking specific drivers.



In the table, Uni drivers refers to universal drivers, while Custom drivers are Xerox custom drivers.

Xerox custom drivers are recommended for use with the DocuPrint N17 since they will generally support the most DocuPrint N17 features.

Table 2.4 DocuPrint N17 driver features

Driver	Image Quality	Cover Sheets	Secure Printing	Edge-to-Edge	N-Up	Water-Mark	Fit-to-size ¹
PCL							
Windows 3.1x (Custom)	Y	Y	Y	Y	N	N	N
Windows 95 (Custom)	Y	Y	Y	Y	N	N	N
Windows NT 3.5.1 (Uni)	N	N	N	N	N	N	N
Windows NT 4.0 (Uni)	Y	N	N	N	Y	N	N
PS							
Windows 3.1x (Custom)	Y	Y	Y	Y	Y	Y	Y
Windows 95 (Custom)	Y	Y	Y	Y	Y	Y	Y
Windows NT 3.5.1 (Uni)	Y	N	N	N	N	N	N
Windows NT 4.0 (Custom)	Y	Y	Y	Y	Y	N	Y
MAC PS	N	N	N	N	N	N	N
OS/2 PS	N	N	N	N	N	N	N
UNIX PS							
Sun Solaris 2.4, 2.5, 2.51, 2.6	N	N	N	N	N	N	N
Sun OS 4.14	N	N	N	N	N	N	N
IBM AIX 4.1x, 4.2x	N	N	N	N	N	N	N
HP-UX 9.x, 10.x	N	N	N	N	N	N	N

¹ Page Policy

Installing CentreWare and Drivers

Inside the cover of the DocuPrint N17 CDs which come with your printer, are booklets which give you instructions on how to load both your DocuPrint N32 drivers and your DocuPrint N17 CentreWare software (depending on your software environment).

In addition, your System Administrator also has the capability to download drivers directly to your workstation.

Configuring Your Drivers

When you initially use any of your drivers, make sure to properly configure your driver by setting the correct DocuPrint N17 options displayed under the “PRINTER CONFIGURATION” tab in the drivers. You can determine which DocuPrint N17 options you have by printing a Configuration Sheet.



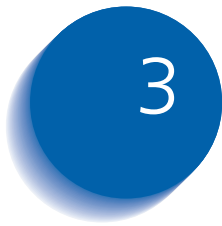

Using the Control Panel

<i>Control Panel Features</i>	3-2
<i>The Display</i>	3-3
<i>Menu Options</i>	3-4

Control Panel Features

The DocuPrint N17 Control Panel (Figure 3.1) serves two purposes:

1. It displays information about the status of the printer (or the job in process) and
2. It provides the means for changing printer settings to control how the DocuPrint N17 operates.

Figure 3.1 DocuPrint N17 Control Panel

- 1 2-line by 16-character display
- 2 Indicator lights
- 3 Control keys (8)

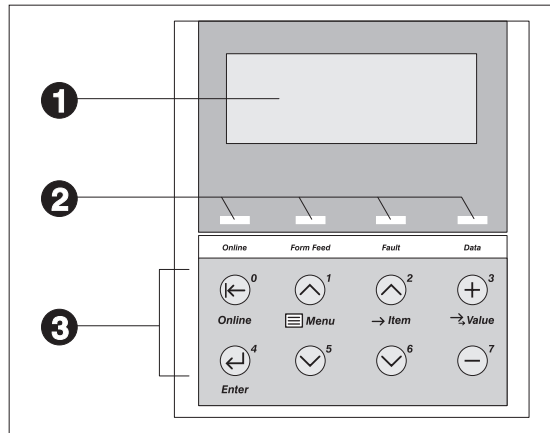

The Display

The Control Panel's display performs two functions.

- It informs you of printer status conditions, such as when toner is low, when a paper tray is empty, when a job is in process, and so on. For example, when you turn on the printer, you see the following message on the display:

Ready

This message appears whenever the printer is online and ready to accept print jobs. The display will also show:

Processing...

when processing data, and:

Waiting

when waiting for more data.

- It presents a hierarchy of menu options and settings to configure and control the printer.

For example, when you press **Menu Up** or **Menu Down**, you will see the following two-line message on the display:

Menus
Item Menu

(such as **System Menu** or **Job Menu**)

See the section “*Menu Options*” (page 3-4) for information on the Menu system hierarchy.

Menu Options

Figure 3.2 on page 3-5 depicts a “Menu Map” for the DocuPrint N17. This map shows which variables are controlled by the DocuPrint N17 menus.

Details of all the available settings for the variables in these menus are contained in Chapter 3 of the System Administrator Guide.

In addition, Chapter 3 of the System Administrator Guide lists all the operations associated with the DocuPrint N17 Control Panel keys and lists the specific key processes which need to be executed to set any of these DocuPrint N17 variables.

Figure 3.2 DocuPrint N17 Menu Map

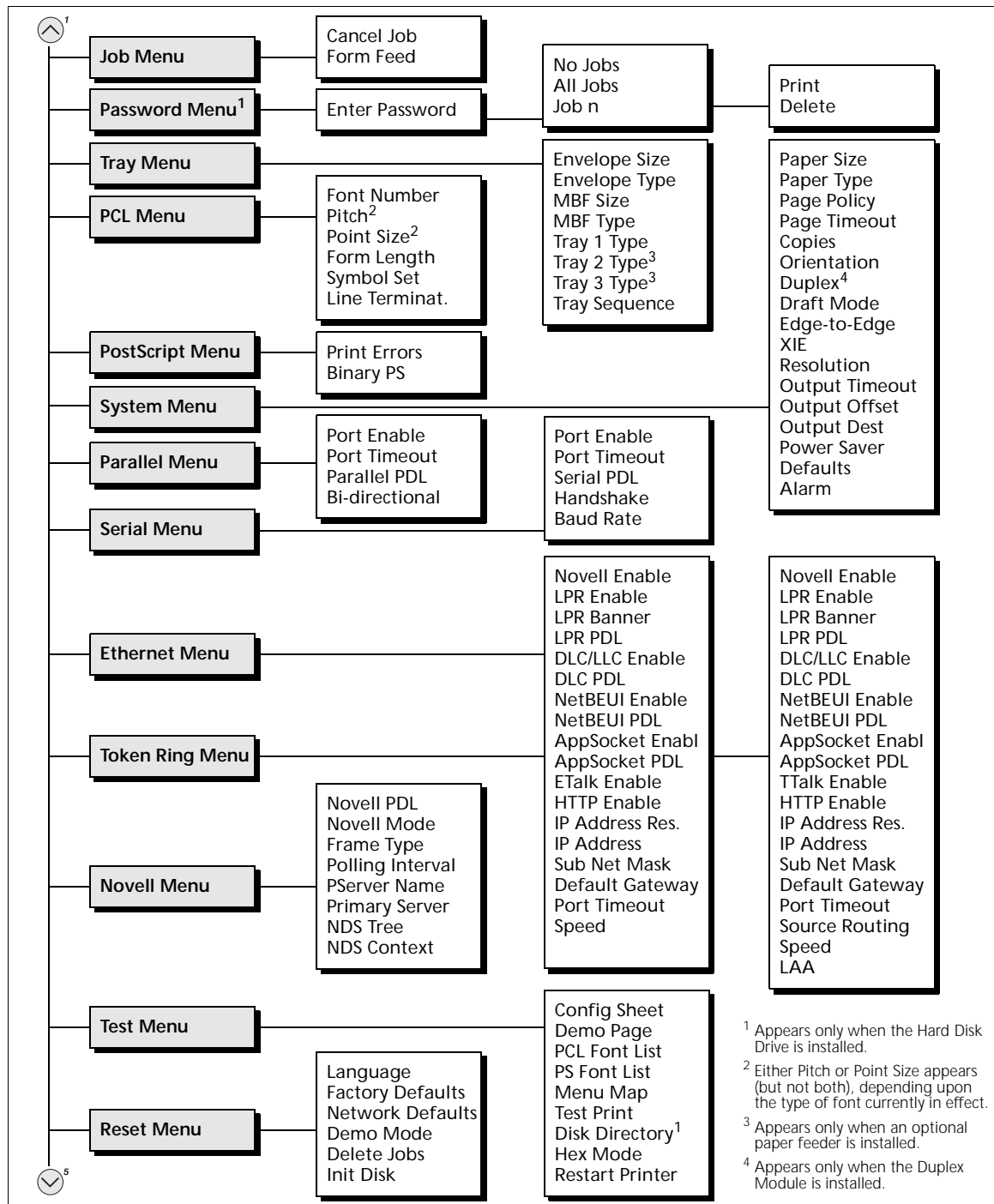

¹ Appears only when the Hard Disk Drive is installed.

² Either Pitch or Point Size appears (but not both), depending upon the type of font currently in effect.

³ Appears only when an optional paper feeder is installed.

⁴ Appears only when the Duplex Module is installed.





4

Paper Loading and Orientation

<i>Selecting Paper</i>	4-2
<i>Storing Paper</i>	4-5
<i>Loading Paper</i>	4-6
<i>Using Tray 1</i>	4-6
<i>Using the MBF</i>	4-9
<i>Using the 500-sheet Paper Deck and Cassette</i>	4-14
<i>Using the High Capacity Feeder</i>	4-17
<i>Using the Envelope Feeder</i>	4-20
<i>Automatic Tray Switching</i>	4-22
<i>Paper Size/Type Mismatch</i>	4-23
<i>Duplex (Two-Sided) Printing</i>	4-24

Selecting Paper

This chapter will help you understand what kinds of paper you can use with the DocuPrint N17 and also how to properly position paper in the different paper input trays so as to accomplish what you want with the DocuPrint N17.

Table 4.1 on page 4-4 lists the size paper, envelopes, and other print media you can use with all DocuPrint N17 input and output bins.

The DocuPrint N17 supports paper weights as follows:

- 16-28 lbs. (60-105 g/m²) via paper trays
- 16-28 lbs. (60-105 g/m²) and A6 international postcard (190 gsm) via the Multi-bypass Feeder (MBF)
- 17-24 lbs. (64-90 g/m²) with duplex
- The optional HCF supports 18-24 lbs. (68-90 g/m²).

Using sizes other than those listed in Table 4.1, or paper not recommended for laser printers, may result in paper jams and print quality problems. The following media are unacceptable for use in the DocuPrint N17:

- Excessively thick or thin paper
- Paper that has already been printed on (preprinted letterhead is allowed)
- Wrinkled, torn or bent paper
- Moist or wet paper
- Curled paper
- Paper with an electrostatic charge

- Glued paper
- Paper with special coating
- Paper unable to withstand a temperature of 150° C (302° F)
- Thermal paper
- Carbon paper
- Paper with paper fasteners, ribbons, tape, etc. attached
- Heavily textured paper
- Label stock with exposed backing sheets

Table 4.1 Acceptable media sizes for all DocuPrint N17 paper trays

Paper Size	Input			Output	
	Tray 1, Tray 2 ¹ and Tray 3 ¹	MBF	Envelope Feeder ¹	Standard Output Bin and OCT ^{1,2}	Duplex Printing ³
Letter (8.5x11" / 216x279mm)	•	•		•	•
Folio (8.5x13" / 216x330mm)	•	•		•	•
Legal (8.5x14" / 216x356mm)	•	•		•	•
Executive (7.25x10.5" / 184x267mm)	⁴	•		•	
Statement (5.5x8.5" / 140x216mm)		•		•	
A4 (210x297mm)	•	•		•	•
A5 (148x210mm)		•		•	
ISO B5 (176x250mm)		•		•	
Envelope COM-10 (4.12x9.5" / 105x241mm) Monarch (3.87x7.5" / 98x191mm) DL (4.33x8.66" / 110x220mm) C5 (6.38x9.01" / 162x229mm)		• • • •	• • • •	• • • •	
Transparency A4 (210x297 mm) Letter (8.5x11" / 216x279mm)		• •		• •	
Label A4 (210x297 mm) Letter (8.5x11" / 216x279mm)		• •		• •	
A6 (International Postcard) (105 x 148mm)		•		•	

¹ Optional paper handler. See *Appendix A of the System Administrator Guide* for information.

² Although the OCT will accept all paper sizes listed, it can only offset A4, Letter, Folio, and Legal.

³ Requires optional Duplex Module. See *Appendix A of the System Administrator Guide* for information.

⁴ Only Tray 1 accepts Executive.

Storing Paper

The DocuPrint N17's print quality is optimized when paper and other print media are properly stored. Proper storage ensures optimum print quality and trouble-free printer options.

- Store the paper on a flat surface, in a relatively low humidity environment.
- Do not unwrap paper until you are ready to use it, and rewrap any paper you are not using.
- Do not expose paper to direct sunlight or high humidity.

Loading Paper

The DocuPrint N17 accepts paper into Tray 1 (see below), the MBF (see page 4-9), the optional 500-sheet Paper Deck and Cassette (see page 4-14), the optional 2,000-sheet High Capacity Feeder (see page 4-17), and the optional Envelope Feeder (see page 4-20).

Using Tray 1

Tray 1 holds 250 sheets of 20 lb (75 g/m²) paper. Refer to the section “*Selecting Paper*” (page 4-2) for acceptable paper sizes and weights.



- Do not attempt to load ANY tray during printing.
- Do not overfill the tray.

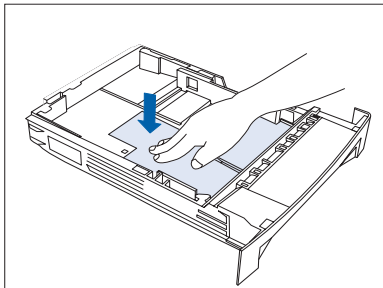

- 1 Press down on the bottom plate of the paper tray until it clicks into position.

If you are not changing paper size, go to Step 4 on page 4-7. Otherwise, continue to Step 2.



If you are changing to a smaller size, perform Steps 2 and 3 in reverse order.

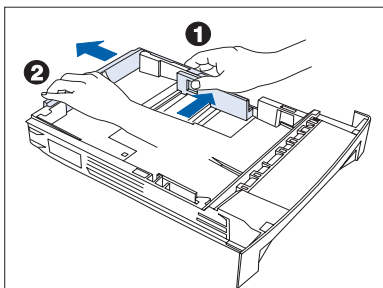

- 2 Push in on the size lock button (1) and slide end guide A (2) out.

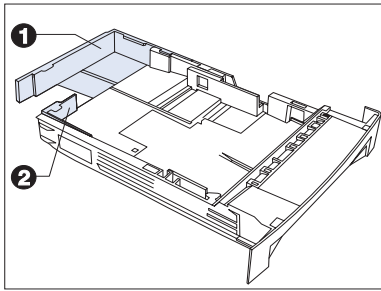

- 3** Slide end guide B (2) out to align it with end guide A (1).

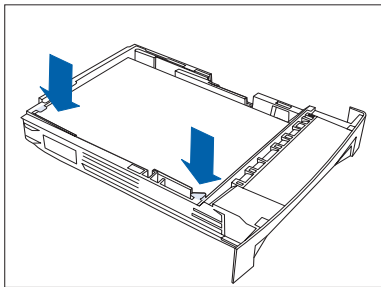

- 4** Load paper so that it is under both the metal stop tab and the plastic fill tabs and adjust the side guide to the edge of the stack as needed. Refer to Figure 4.1 on page 4-8 for correct paper orientation.



Ensure that all sheets of paper are aligned in the paper tray. It should not be necessary to fan the paper before loading it, however if paper feeding problems occur with some paper, you may want to remove the paper and lightly fan it.



The type of paper loaded (plain, prepunched, letterhead, transparency, etc.) must be set using the Tray 1 Type item in the Control Panel's Tray Menu (refer to Chapter 3 of the System Administrator Guide).

Figure 4.1 Tray 1 paper orientation

Top View

- 1 Drilled paper (simplex or duplex printing)
- 2 Letterhead (duplex printing)
- 3 Letterhead (simplex printing)

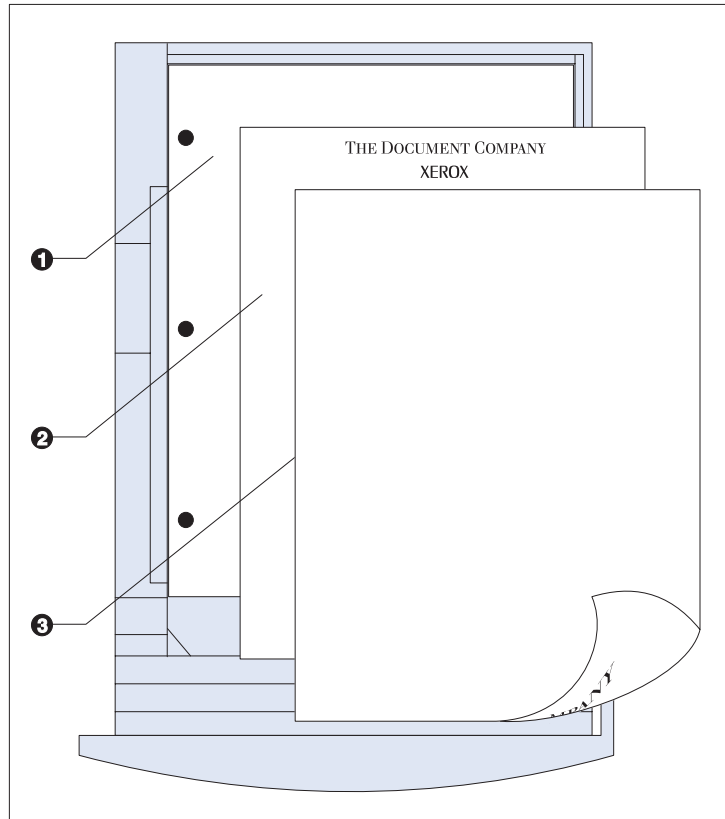

Using the MBF

The MBF accepts all paper sizes, weights and types listed in the section “*Selecting Paper*” (page 4-2).

The MBF holds:

- 100 sheets of 20 lb (75 g/m²) paper
- 30 transparencies or 25 sheets of label paper
- 10 envelopes

Consult Figure 4.2 on page 4-12 for proper orientation of letterhead and drilled paper in the MBF, and Figure 4.3 on page 4-13 for proper orientation of envelopes and postcards in the MBF.

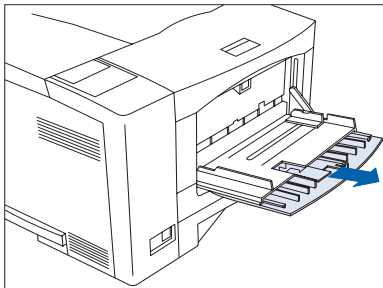

- 1** Press the MBF release point to open the MBF, then pull out the tray extension.

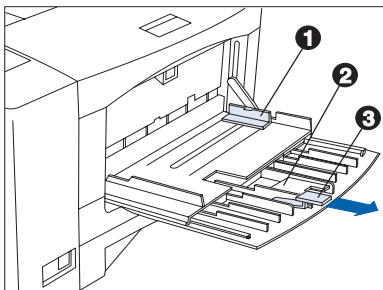

- 2** Slide the side guide (1) to the far right.
Flip open the extension bar (2) if feeding long paper. Pull out the envelope stopper (3) if feeding envelopes.

Loading Paper

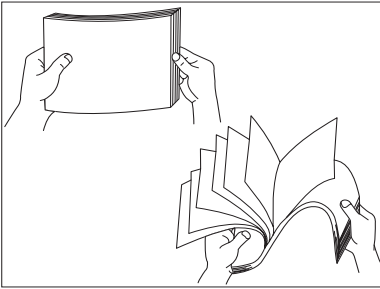

- 3** Fan transparencies and label paper before loading in the tray.

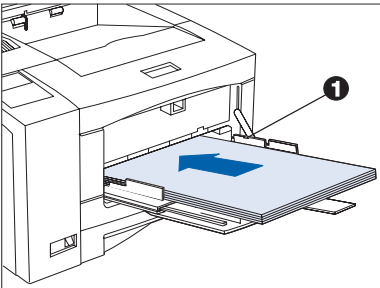

- 4** Insert paper along the left side of the tray, under the plastic maximum fill tab (1). Refer to Figure 4.2 on page 4-12 for correct paper orientation.

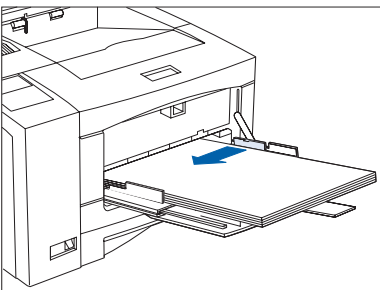

- 5** Adjust the side guide to the size of the paper loaded in the MBF.

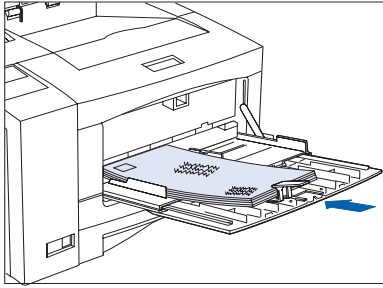

- 6** When feeding envelopes, slide the end of the envelope stopper over the end of the envelope stack. Refer to Figure 4.3 on page 4-13 for correct envelope orientation.

 *The envelope stopper keeps envelopes from backing out of the stack while feeding.*

- 7** Because the MBF does not have a paper size sensor, you must tell the printer which size paper is loaded via the MBF Size item in the Control Panel's Tray Menu. The type of paper (plain, prepunched, letterhead, transparency, etc.) must also be set, using the Tray Menu's MBF Type item.

See *Chapter 3: Using the Control Panel* for instructions on accessing menus.

 *When you send a job to the printer that requests a paper size that is different than the size currently in the MBF, the printer will perform as discussed in the section "Paper Size/Type Mismatch" (page 4-23).*

Figure 4.2 MBF paper orientation

Top View

- 1 Drilled paper (simplex or duplex printing)
- 2 Letterhead (simplex printing)
- 3 Letterhead (duplex printing)

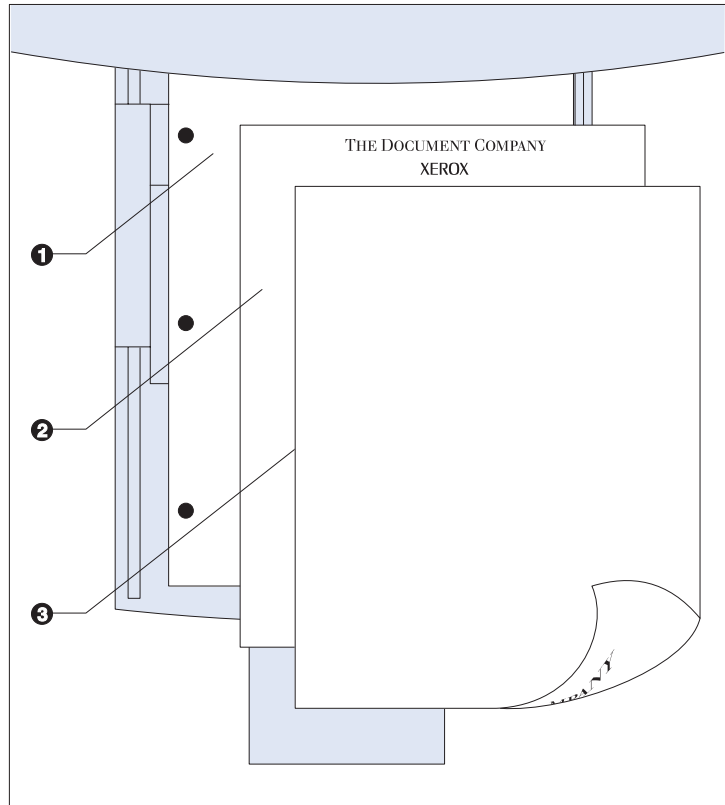
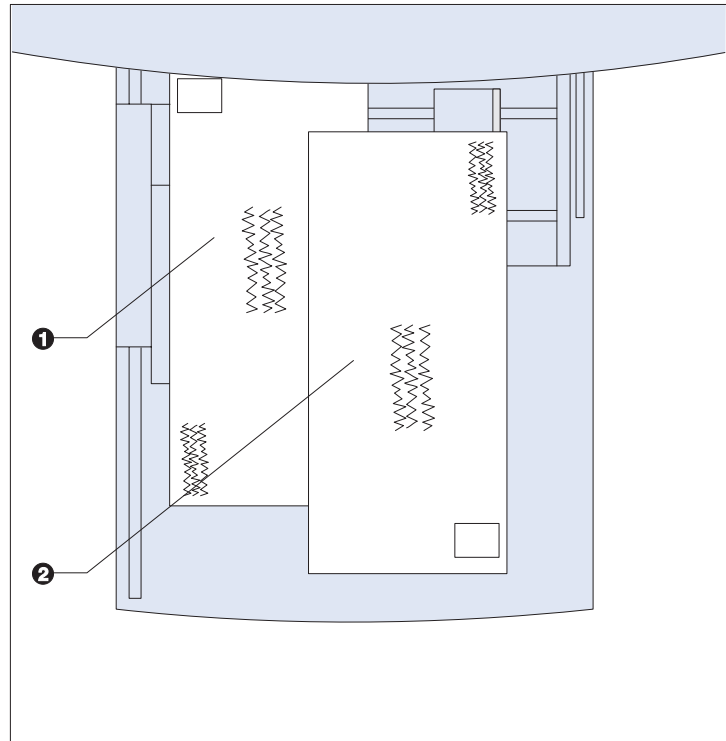

Figure 4.3 MBF envelope and postcard orientation

Top View

- 1 Standard orientation (PCL)
- 2 Alternate orientation¹



¹ For PostScript applications: Some PostScript applications require that the envelopes/post cards be loaded with the return address corner on the right side of the stack and leading as the envelopes/post cards go into the printer. Test your application for proper orientation.

Using the 500-sheet Paper Deck and Cassette

The optional 500-sheet Paper Deck and Cassette holds 500 sheets of 20 lb (75 g/m²) paper. Refer to the section “*Selecting Paper*” (page 4-2) for acceptable paper sizes and weights.



When installed, the 500-sheet Paper Deck and Cassette is accessed as Tray 2. If two Decks are installed, the lower one is accessed as Tray 3.

(See Appendix A of the System Administrator Guide for ordering information and Appendix C of the System Administrator Guide for installation instructions.)



- Do not attempt to load the 500-sheet Paper Deck and Cassette during printing.
 - Do not overfill the paper cassette.
-

If you are not changing paper size, go to Step 2.

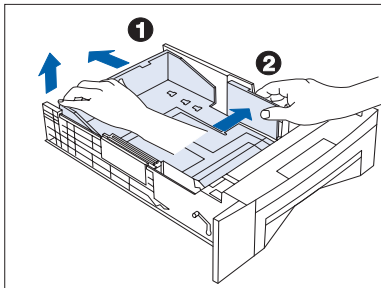

- 1** Adjust the end and width guides to fit the size of paper you are loading.
 - A** Lift up one side of the end guide (1) at the rear of the tray, then lift up the other side of the end guide.
 - B** Pull out the tray to lengthen it, or push it in to shorten it.
 - C** Press both sides of the end guide down until it clicks into place at the desired length.
 - D** Slide the width guide (2) to fit the width of the paper.

- 2** Load paper. Refer to Table 4.4 on page 4-16 for correct paper orientation.
 -  *The type of paper loaded (plain, prepunched, letterhead, transparency, etc.) must be set using the Tray 2 Type (or Tray 3 Type) item in the Control Panel's Tray Menu (refer to Chapter 3 of the System Administrator Guide).*

Figure 4.4 500-sheet Paper Deck paper orientation

Top View

- 1** Drilled paper
(simplex or duplex printing)
- 2** Letterhead
(duplex printing)
- 3** Letterhead
(simplex printing)

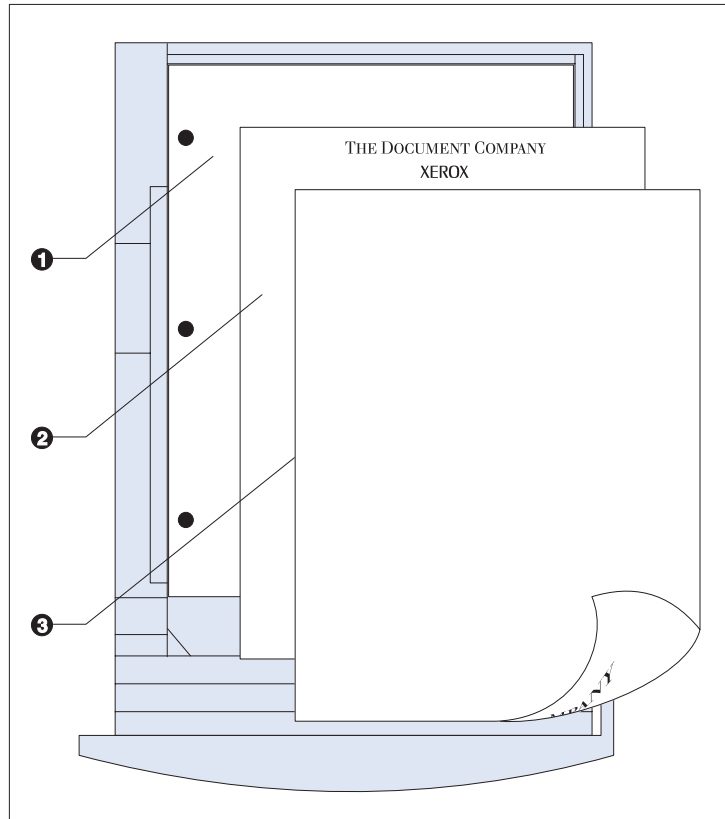

Using the High Capacity Feeder

The optional High Capacity Feeder (HCF) holds 2,000 sheets of 20 lb (75 g/m²) paper. Refer to the section “*Selecting Paper*” (page 4-2) for acceptable paper sizes and weights.

(See *Appendix A of the System Administrator Guide* for ordering information and *Appendix C of the System Administrator Guide* for installation instructions.)



When the HCF is installed, it can be accessed using your existing applications/drivers as Tray 2 (or as Tray 3 if a 500-Sheet Paper Deck and Cassette is also installed).



- Do not attempt to load the High Capacity Feeder during printing.
 - Do not overfill the feeder.
-

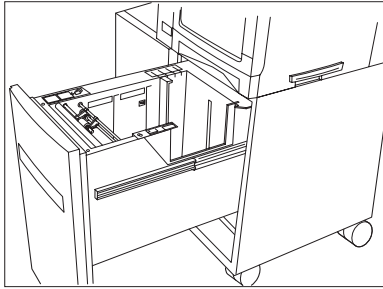

- 1** Open the paper drawer, and wait until tray fully lowers.
If you are not changing paper size, go to Step 3 below.
Otherwise, continue to Step 2.

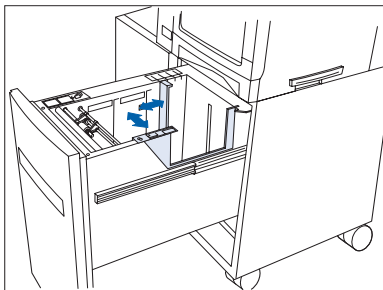

- 2** Adjust the end and side paper guides for paper size.
Ensure that both the top and bottom of the paper guides are seated into the correct size slots.

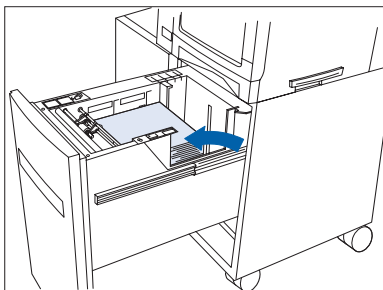

- 3** Load paper using the opening in the side of the drawer.
Refer to Figure 4.5 on page 4-19 for correct paper orientation.

 *The type of paper loaded (plain, prepunched, letterhead, transparency, etc.) must be set using the Tray 2 Type (or Tray 3 Type) item in the Control Panel's Tray Menu (refer to Chapter 3 of the System Administrator Guide).*

Figure 4.5 High Capacity Feeder paper orientation

Top View

- 1 Legal size paper guide position
- 2 Folio size paper guide position
- 3 A4 size paper guide position
- 4 Letter size paper guide position
- 5 Drilled paper (simplex or duplex printing)
- 6 A4 size paper guide position
- 7 Letter/legal/folio size paper guide position
- 8 Letterhead (duplex printing)
- 9 Letterhead (simplex printing)

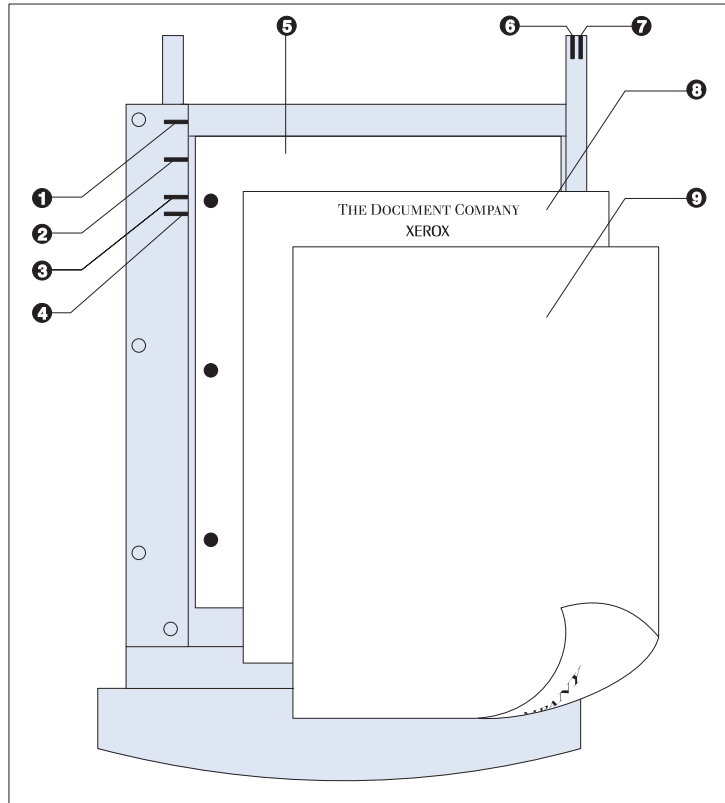

Using the Envelope Feeder

The Envelope Feeder is an optional paper handling device available for the DocuPrint N17. Refer to Table 4.1 on page 4-4 for acceptable envelope sizes.

(See *Appendix A of the System Administrator Guide* for ordering information and *Appendix C of the System Administrator Guide* for installation instructions.)

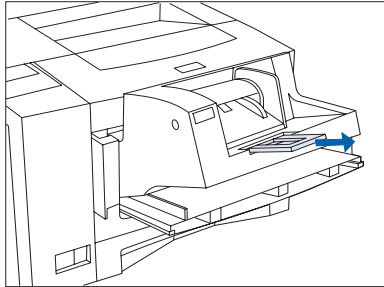

- 1 Slide out the envelope support.

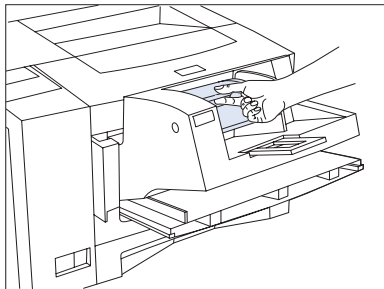

- 2 Lift the envelope holder.

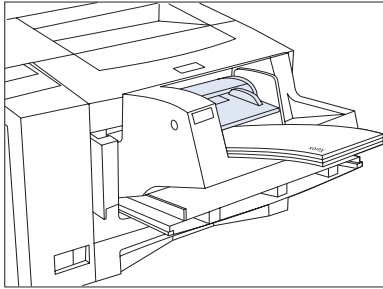

- 3** Stack the envelopes face up with the stack against the feeder's left edge.

For PCL applications: The corner for the return address should be on the left side of the stack and trailing as the envelopes go into the printer (as shown at left).

For PostScript applications: Some PostScript applications require that the envelopes be loaded with the return address corner on the right side of the stack and leading as the envelopes go into the printer. Test your application for proper orientation.



Push the envelopes gently into the printer. Do not force the envelopes between the last two rollers (the two that touch), as this may cause a jam to occur.

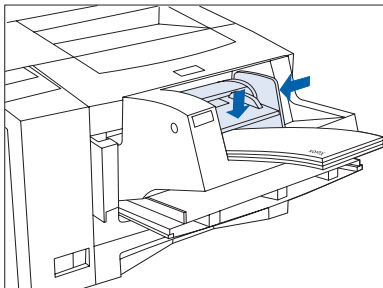

- 4** Adjust the side guide against the right side of the stack and lower the envelope holder.



Do not stack envelopes higher than the red "full" line on the side guide, nor push the side guide so hard against the stack as to deform the envelopes.

- 5** Because the Envelope Feeder does not have a paper size sensor, you must tell the printer which size envelope is loaded via the Envelope Size item in the Control Panel's Tray Menu. The type of envelope (plain, prepunched, letterhead, transparency, etc.) must also be set, using the Tray Menu's Envelope Type item.

See *Chapter 3: Using the Control Panel* for instructions on accessing menus.



With the Envelope Feeder installed, the MBF may still be used.

Automatic Tray Switching

Automatic tray switching, available for both PCL and PostScript jobs, enables you to group two or more input trays together into one logical tray, and in a specific order in which the trays will be searched to satisfy an input request. Tray switching is useful for:

- Increasing paper capacity.

When the current paper tray runs out of paper, the printer automatically switches to the next tray in the sequence, provided the paper size and type in the next tray is the same size and type as that in the current tray.

- Searching for the correct paper size and type.
- If the paper size and type specified in your software application does not match the paper loaded in the current paper tray, the printer automatically searches the next tray in the sequence for a paper size and type that matches.

Tray switching is made possible via the Tray Sequence item in the Control Panel's Tray Menu. It enables grouping of Tray 1 in the printer, the MBF, and optional Trays 2 and 3 (if installed) into a variety of sequence combinations. Tray switching can also be turned off.

Following is a description of the settings and rules for using the Tray Sequence function, along with examples of its use. For more information on using the Control Panel to set Tray Sequence, refer to *Chapter 3 of the System Administrator Guide*.

Paper Size/Type Mismatch

Paper size/type mismatch occurs when the requested size is not available in the printer. This can be caused by running out of paper in a tray that is configured for the requested paper, or by requesting a paper that is not configured in the printer. The printer goes off-line under paper mismatch conditions. It automatically returns on-line and continues printing after the paper mismatch condition is resolved.

If a tray is configured for the requested paper, but the tray is out of paper, the display prompts you to load the requested paper (size and type) in the appropriate tray. After the tray is loaded, printing continues.

If the request is for paper that is not configured in the printer, you are prompted to load the requested paper in the first tray of the Tray Sequence setting.

If you do not want to load paper in the first tray of the Tray Sequence setting, two options are available:

- One of the trays may be loaded with the requested size paper and reconfigured via the Tray Menu to match the requested paper type. (See *Chapter 3 of the System Administrator Guide* for instructions on using the Tray Menu.)
- **Value Up** or **Value Down** may be pressed to scroll through all the trays, displaying the size and type paper in each tray. If one of these alternate papers is acceptable, pressing **Enter** will cause printing to continue on the new paper. Trays are searched in the order specified in the Tray Sequence setting.

Duplex (Two-Sided) Printing

Once the optional Duplex Module is installed, you can print two-sided (duplex) jobs.

(See *Appendix A of the System Administrator Guide* for ordering information and *Appendix C of the System Administrator Guide* for installation instructions.)

Use only the size paper listed in Table 4.2 for two-sided jobs. Do not use envelopes, postcards, transparencies, or label paper for duplex jobs.

Table 4.2 Paper sizes that can be used with the Duplex Module

Paper Size	Weight
A4 (210x297 mm)	20 lb (75 g/m ²) to 24 lb (90 g/m ²)
Letter (8.5x11" / 216x279mm)	20 lb (75 g/m ²) to 24 lb (90 g/m ²)
Folio (Legal 13") (8.5x13" / 216x330mm)	20 lb (75 g/m ²) to 24 lb (90 g/m ²)
Legal (Legal 14") (8.5x14" / 216x356mm)	20 lb (75 g/m ²) to 24 lb (90 g/m ²)

Refer to Table 4.6 on page 4-25 for the proper orientation of letterhead when printing duplex.

Print Orientation and Control Panel Settings

To ensure that duplex jobs print in the proper orientation, set the Duplex option (in the System Menu) to the appropriate setting (see Figure 4.6). The Duplex settings for both PCL and PostScript are as follows:

Duplex = Off

Duplex = Short Edge, or

Duplex = Long Edge

Figure 4.6 Duplex binding orientation and Control Panel menu settings

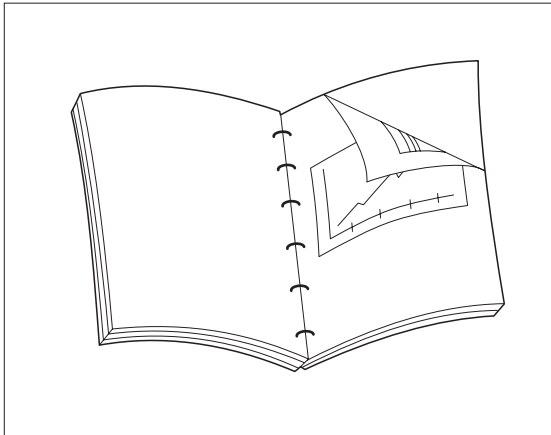

Portrait Orientation: Set Duplex to *Long Edge*.

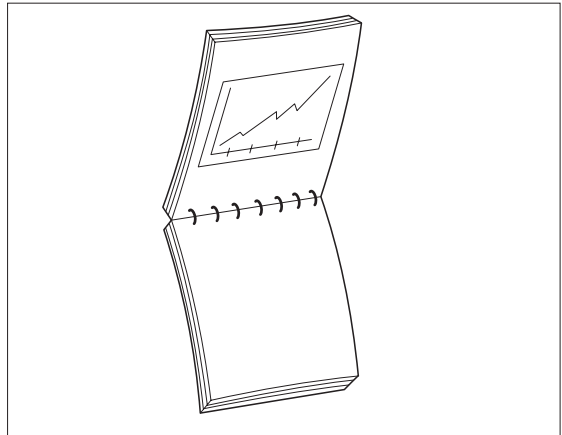

Portrait Orientation: Set Duplex to *Short Edge*.

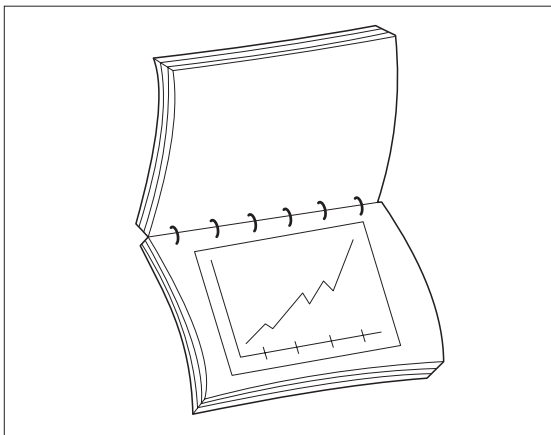

Landscape Orientation: Set Duplex to *Long Edge*.

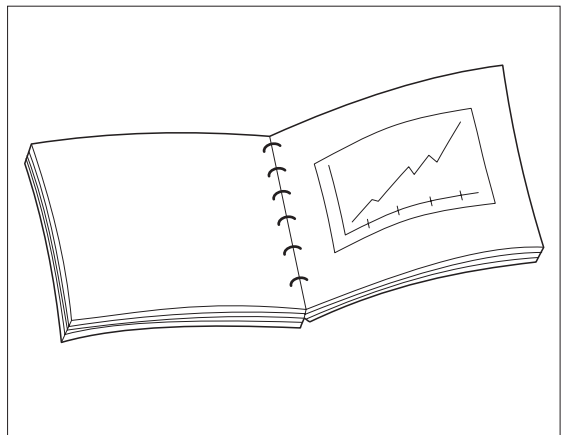

Landscape Orientation: Set Duplex to *Short Edge*.





5

Clearing Jams and Jam Recovery

Paper Jams	5-2
Clearing Paper Jams	5-3
<i>What Causes a Paper Jam?</i>	5-2
<i>Tray 1 Jam</i>	5-7
<i>MBF Jam</i>	5-8
<i>Tray 2 Jam with 500-sheet Paper Deck and Cassette</i>	5-9
<i>Tray 3 Jam with 500-sheet Paper Deck and Cassette</i>	5-10
<i>Tray 2 or Tray 3 Jam with 2,000-sheet HCF</i>	5-11
<i>Envelope Feeder Jam</i>	5-12
<i>OCT Jam</i>	5-13
<i>Duplex Module Jam</i>	5-14
<i>Paper Exit Jam</i>	5-15
<i>EP Cartridge Jam</i>	5-16
<i>Paper Mismatch Jam</i>	5-17
<i>Misfeed Jam at Startup</i>	5-18
<i>Fuser Jam</i>	5-19

Paper Jams

Your DocuPrint N17 printer has been designed to provide reliable, trouble-free operation. However, you may experience an occasional paper jam.

When the printer detects a misfeed or a paper jam, the printing process is halted and a Control Panel message is displayed.

After the paper jam has been cleared, the printer will resume operation to complete the print job. The pages in the print engine will be reprinted when the jam is cleared and printing resumes.

What Causes a Paper Jam?

Paper jams occur most often when:

- The paper stock does not meet specification. See *Chapter 4: Paper Loading and Orientation*.
- The paper stock is in poor condition.
- The printer needs cleaning.
- Printer parts are worn and need to be replaced.

Clearing Paper Jams

Table 5.1 on page 5-4 lists the types of paper jams that may occur. If you see a Control Panel message that indicates a paper jam, find the message in the left-hand column and perform the accompanying steps to clear the paper jam.



Be careful not to touch any of the components inside the printer when removing jammed paper. They may be very hot.

Table 5.1 Paper jam messages

Message	Description/Corrective Action
<p>Paper Size Jam- Open Rear Cover</p> <p>followed by:</p> <p>Clear Paper Path</p>	<p>A paper jam has occurred because the size of the paper fed was not the size expected by the printer. The jam must be cleared and expected paper loaded.</p> <p>ACTION: Use the procedure <i>"Paper Mismatch Jam"</i> (page 5-17).</p>
<p>Paper Jam- Open Front Cover</p> <p>followed by:</p> <p>Remove PrintCart Clear Paper Path</p>	<p>A paper jam has occurred inside the front cover.</p> <p>ACTION: Use the procedure <i>"EP Cartridge Jam"</i> (page 5-16).</p>
<p>Paper Jam- Open Rear Cover</p> <p>followed by:</p> <p>Clear Paper Path</p>	<p>A paper jam has occurred inside the rear cover.</p> <p>ACTION: Use the procedure <i>"Paper Exit Jam"</i> (page 5-15).</p>
<p>Paper Jam- Open Rear Cover</p> <p>followed by:</p> <p>Remove DuplxUnit Clear Paper Path</p>	<p>A paper jam has occurred inside the rear cover.</p> <p>ACTION: Use the procedure <i>"Duplex Module Jam"</i> (page 5-14).</p>
<p>Env. Feeder Jam- Remove All Envel</p> <p>followed by:</p> <p>Remove EnvFeeder Open Front Cover</p> <p>then:</p> <p>Remove Jam Envel</p>	<p>A paper jam has occurred at or before the input sensor. The envelope was fed (or intended to be fed) from the Envelope Feeder.</p> <p>ACTION: Use the procedure <i>"Envelope Feeder Jam"</i> (page 5-12).</p>

Table 5.1 Page 1 of 3

Table 5.1 Paper jam messages (continued)

Message	Description/Corrective Action
Tray 1 Jam- Open Tray 1 followed by: Open Front Cover Remove Jam Sheet	A paper jam has occurred at or before the printer's input sensor. The paper was fed (or intended to be fed) from Tray 1. ACTION: Use the procedure "Tray 1 Jam" (page 5-7).
Tray 2 Jam- Open Tray 2 followed by: Open Front Cover Remove Jam Sheet	A paper jam has occurred at or before the printer's input sensor. The paper was fed (or intended to be fed) from Tray 2. ACTION: If a 500-sheet Paper Deck and Cassette is in use as Tray 2, use the procedure "Tray 2 Jam with 500-sheet Paper Deck and Cassette" (page 5-9). If a 2,000-sheet HCF is in use as Tray 2, use the procedure "Tray 2 or Tray 3 Jam with 2,000-sheet HCF" (page 5-11).
Tray 3 Jam- Open Tray 3 followed by: Open Front Cover Remove Jam Sheet	A paper jam has occurred at or before the printer's input sensor. The paper was fed (or intended to be fed) from Tray 3. ACTION: If a 500-sheet Paper Deck and Cassette is in use as Tray 3, use the procedure "Tray 3 Jam with 500-sheet Paper Deck and Cassette" (page 5-10). If a 2,000-sheet HCF is in use as Tray 3, use the procedure "Tray 2 or Tray 3 Jam with 2,000-sheet HCF" (page 5-11).
MBF Jam- Remove All Paper followed by: Open Front Cover Remove Jam Sheet	A paper jam has occurred while feeding from the Multi-bypass Feeder (MBF). ACTION: Use the procedure "MBF Jam" (page 5-8).

Table 5.1 Page 2 of 3

Table 5.1 Paper jam messages *(continued)*

Message	Description/Corrective Action
<p>Offset Jam- Open Rear Cover</p> <p>followed by:</p> <p>Open Offset Door Clear Paper Path</p>	<p>A paper jam has occurred at the OCT. The paper did not reach the input sensor.</p> <p>ACTION: Use the procedure <i>"OCT Jam"</i> (page 5-13).</p>
<p>Tray Jam- Open All Trays</p> <p>followed by:</p> <p>Open Front Cover Remove Jam Sheet</p>	<p>A jam in the input trays has been found at startup, and all trays must be opened to find the jam.</p> <p>ACTION: Use the procedure <i>"Misfeed Jam at Startup"</i> (page 5-18).</p>
<p>Table 5.1 Page 3 of 3</p>	

Tray 1 Jam

Follow the procedure below to clear a paper jam from Tray 1 when the Control Panel displays the message:

Tray 1 Jam-
Open Tray 1

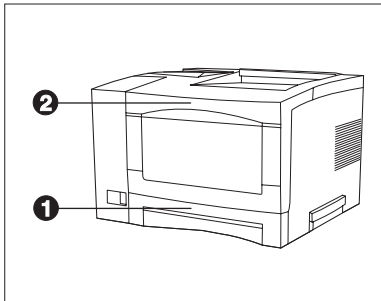

- 1** Remove Tray 1 (1).
- 2** Remove the Envelope Feeder if installed.
- 3** Open the front cover (2).
- 4** Remove the EP Cartridge.
- 5** Remove the jammed sheet.
- 6** Replace the EP Cartridge.
- 7** Replace Tray 1.
- 8** Close the front cover.
- 9** Replace the Envelope Feeder if necessary.

MBF Jam

Follow the procedure below to clear a paper jam from the Multi-bypass Feeder (MBF) when the Control Panel displays the message:

MBF Jam-
Remove All Paper

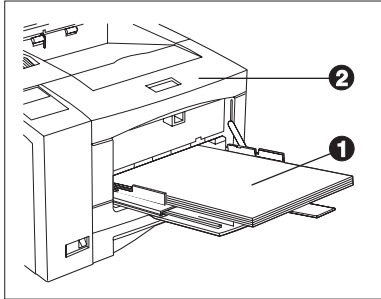

- 1** Remove all paper from the MBF (1).
- 2** Remove the Envelope Feeder if installed.
- 3** Open the front cover (2).
- 4** Remove the jammed sheet of paper.
- 5** Close the front cover.
- 6** Reload the MBF.
- 7** Replace the Envelope Feeder if necessary.

Tray 2 Jam with 500-sheet Paper Deck and Cassette

Follow the procedure below to clear a paper jam from Tray 2 when Tray 2 is a 500-sheet Paper Deck and Cassette and the Control Panel displays the message:

Tray 2 Jam-
Open Tray 2

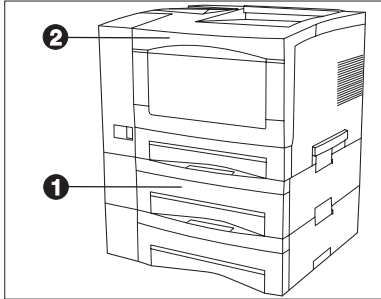

- 1** Remove Tray 2 (1).
- 2** Remove the Envelope Feeder if installed.
- 3** Open the front cover (2).
- 4** Remove the EP Cartridge.
- 5** Remove the jammed sheet of paper.
- 6** Replace the EP Cartridge.
- 7** Replace Tray 2.
- 8** Close the front cover.
- 9** Replace the Envelope Feeder if necessary.

Tray 3 Jam with 500-sheet Paper Deck and Cassette

Follow the procedure below to clear a paper jam from Tray 3 when Tray 3 is a 500-sheet Paper Deck and Cassette and the Control Panel displays the message:

Tray 3 Jam-
Open Tray 3

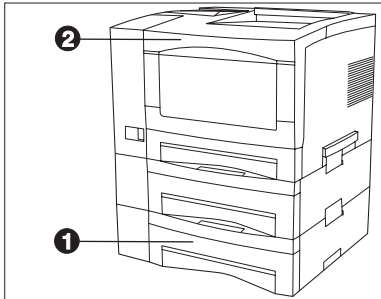

- 1 Remove Tray 3 (1).
- 2 Remove the Envelope Feeder if installed.
- 3 Open the front cover (2).
- 4 Remove the EP Cartridge.
- 5 Remove the jammed sheet of paper.
- 6 Replace the EP Cartridge.
- 7 Replace Tray 3.
- 8 Close the front cover.
- 9 Replace the Envelope Feeder if necessary.

Tray 2 or Tray 3 Jam with 2,000-sheet HCF

Follow the procedure below to clear a paper jam from Tray 2 or Tray 3 when the specified tray is the 2,000-sheet High Capacity Feeder (HCF) and the Control Panel displays the message:

Tray 2 Jam-
Open Tray 2

or:

Tray 3 Jam-
Open Tray 3

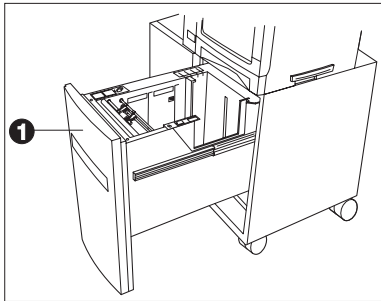

- 1** Open the paper drawer (1).
- 2** Remove the Envelope Feeder if installed.
- 3** Open the printer's front cover.
- 4** Remove the EP Cartridge.
- 5** Remove the jammed sheet of paper.
- 6** Replace the EP Cartridge.
- 7** Close the paper drawer.
- 8** Close the printer's front cover.
- 9** Replace the Envelope Feeder if necessary.

Envelope Feeder Jam

Follow the procedure below to clear a paper jam from the Envelope Feeder when the Control Panel displays the message:

Env. Feeder Jam-
Remove All Envel

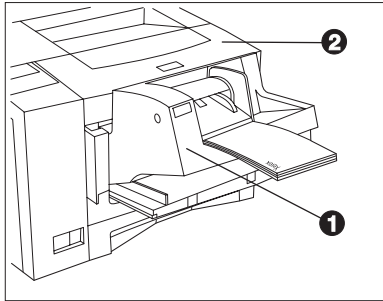

- 1** Remove all envelopes from the Envelope Feeder (1).
- 2** Remove the Envelope Feeder.
- 3** Open the front cover (2).
- 4** Remove the EP Cartridge.
- 5** Remove the jammed envelope.
- 6** Replace the EP Cartridge.
- 7** Close the front cover.
- 8** Replace the Envelope Feeder.
- 9** Reload the Envelope Feeder.

OCT Jam

Follow the procedure below to clear a paper jam from the Offset Catch Tray (OCT) when the Control Panel displays the message:

Offset Jam-
Open Rear Cover

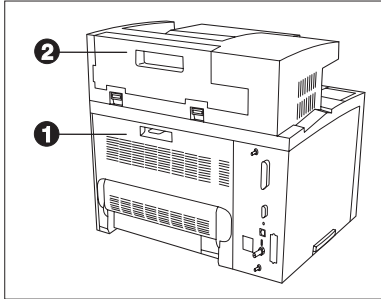

- 1 Open the printer's rear cover (1).
- 2 Open the OCT's rear cover (2).
- 3 Remove the jammed paper.
- 4 Close the OCT's rear cover.
- 5 Close the printer's rear cover.

Duplex Module Jam

Follow the procedure below to clear a paper jam from inside the rear cover when a Duplex Module is installed and the Control Panel displays the message:

Paper Jam-
Open Rear Cover

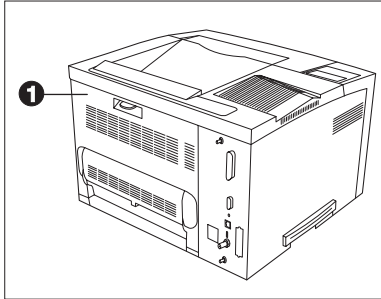

- 1 Open the rear cover (1).
- 2 Remove the Duplex Module.
- 3 Remove the jammed paper.
- 4 Replace the Duplex Module.
- 5 Close the rear cover.



On rare occasions, paper may jam in the fuser. To clear a fuser jam, refer to the section “Fuser Jam” (page 5-19).

Paper Exit Jam

Follow the procedure below to clear a paper jam inside the rear cover when the Control Panel displays the message:

Paper Jam-
Open Rear Cover

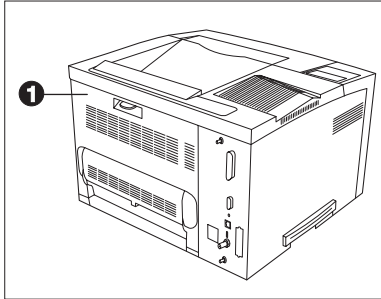

- 1 Open the rear cover (1).
- 2 Remove the jammed paper.
- 3 If you do not see the jammed paper, remove the Duplex Module, remove the jammed paper, then replace the Duplex Module.
- 4 Close the rear cover.



On rare occasions, paper may jam in the fuser. To clear a fuser jam, refer to the section "Fuser Jam" (page 5-19).

EP Cartridge Jam

Follow the procedure below to clear a paper jam from inside the front cover when the Control Panel displays the message:

Paper Jam-
Open Front Cover

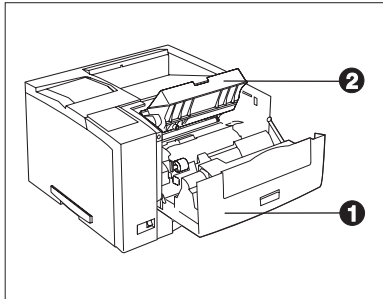

- 1 Remove the Envelope Feeder if installed.
- 2 Open the front cover (1).
- 3 Remove the EP cartridge (2).
- 4 Remove the jammed paper.
- 5 Replace the EP cartridge.
- 6 Close the front cover.
- 7 Replace the Envelope Feeder if necessary.



On rare occasions, paper may jam in the fuser. To clear a fuser jam, refer to the section "Fuser Jam" (page 5-19).

Paper Mismatch Jam

Follow the procedure below to clear a paper jam when the Control Panel displays the message:

Paper Size Jam-
Open Rear Cover

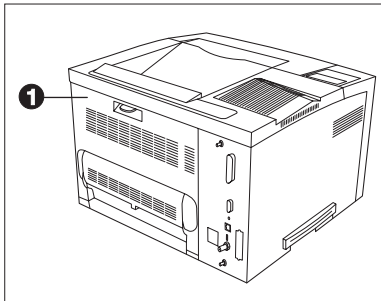

- 1** Change the loaded paper to the correct size.
- 2** Open the rear cover (1).
- 3** Remove the jammed paper.
- 4** Close the rear cover.
- 5** If the problem paper was in the MBF or the Envelope Feeder, check that the corresponding menus are set to the size loaded.

Misfeed Jam at Startup

Follow the procedure below to clear a paper jam when the Control Panel displays the message:

Tray Jam-
Open All Trays

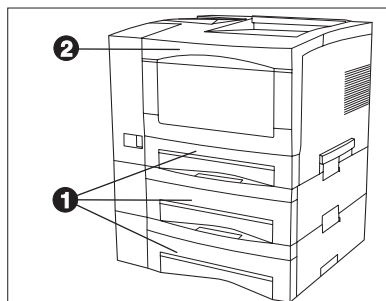

- 1 Remove all trays (1).
- 2 Remove the Envelope Feeder if installed.
- 3 Open the front cover (2).
- 4 Remove the jammed paper.
- 5 Replace all trays.
- 6 Close the front cover.
- 7 Replace the Envelope Feeder if necessary.

Fuser Jam

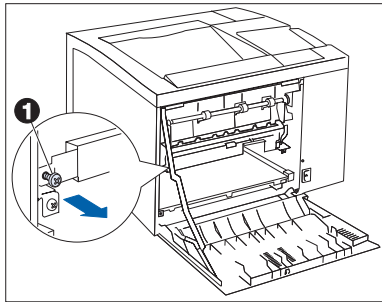

Follow the procedure below to clear a paper jam when paper is jammed in the fuser.

- 1** Power OFF the printer and disconnect the power cord.
- 2** Open the rear cover.
- 3** Let the fuser area cool for 40 minutes.
- 4** Remove the Duplex Module, if installed.
- 5** Remove the screw at the left side of the fuser cover (1).
- 6** Flip down the fuser cover.
- 7** Remove the jammed paper.
- 8** Close the fuser cover and replace the screw.
- 9** Replace the Duplex Module, if removed.
- 10** Close the rear cover.
- 11** Plug in the power cord and power ON the printer.



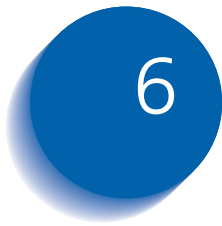

Replacing Consumables

<i>Replacing the EP Cartridge</i>	<i>6-2</i>
<i>Replacing the Fuser Cartridge/BTR</i>	<i>6-5</i>

Replacing the EP Cartridge



- Do not expose the EP (electronic printing) cartridge to direct sunlight or artificial light for more than 15 minutes. Overexposure will permanently damage the photosensitive imaging drum.
- Do not open the drum shutter or touch the green imaging drum.
- Complete the EP cartridge installation within 15 minutes of removing the cartridge from its package.

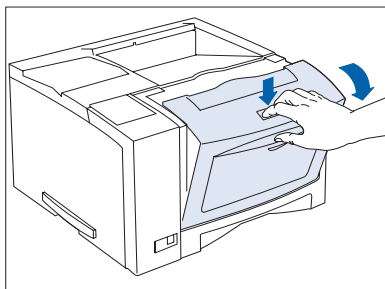

- 1 Open the front cover by pressing the button on top of the cover.

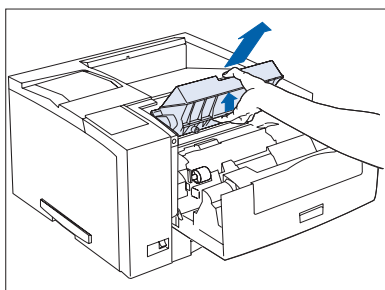

- 2 Remove the old EP cartridge by lifting it towards the rear of the printer then pulling it up and out.



Do not discard the old EP cartridge. Return it to Xerox. Refer to the printed instructions accompanying the EP cartridge.

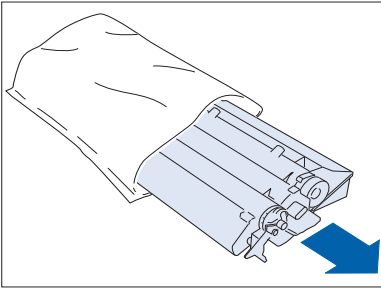

3 Remove the new EP cartridge from its wrapper.

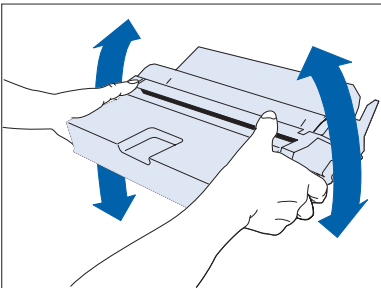

4 Gently shake the EP cartridge several times to evenly distribute the toner.

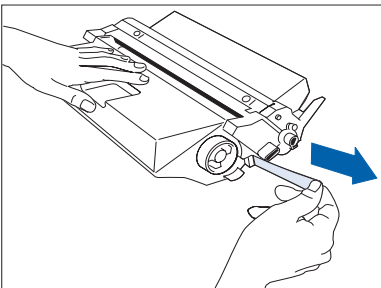

5 Remove the tape strip.

Replacing the EP Cartridge

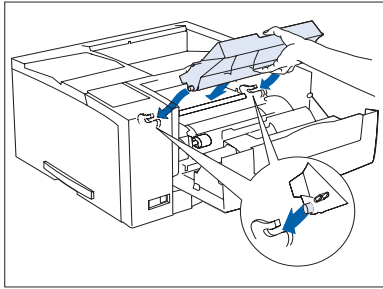

- 6 Insert the EP cartridge into the guide channels marked by the arrows inside the front cover. Push in until it clicks in place, then close the front cover.

Replacing the Fuser Cartridge/BTR



- The fuser area is extremely hot. Turn the printer OFF and allow it to cool for 40 minutes before replacing an existing fuser cartridge.
- Replacing the BTR (Bias Transfer Roll) requires removing the EP cartridge. Do not expose the EP cartridge to direct sunlight or artificial light for more than 15 minutes. Overexposure will permanently damage the photosensitive imaging drum.

- 1 Power OFF the printer and disconnect the power cord.
- 2 Open the rear cover.

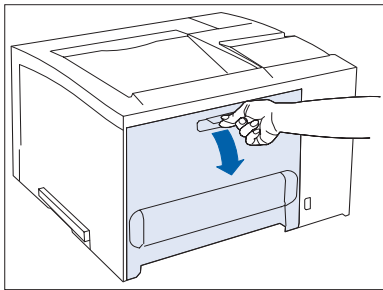

- 3 Let the fuser area cool for 40 minutes.

If the Duplex Module is installed, continue with Step 4 on page 6-6. Otherwise, skip to Step 5 on page 6-6.

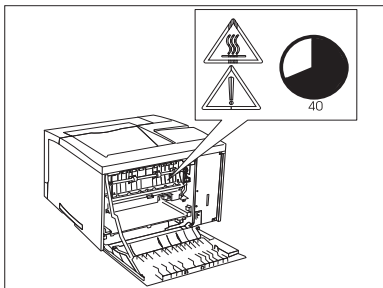

Replacing the Fuser Cartridge/BTR

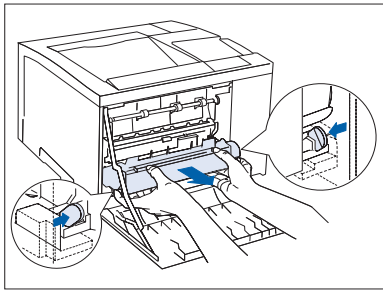

- 4 Remove the Duplex Module by pushing the green lock buttons on either side of it.

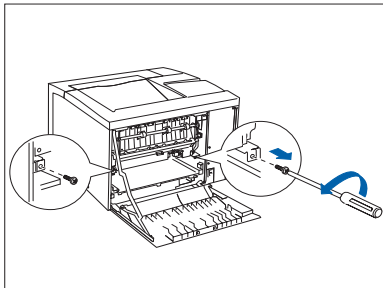

- 5 Remove the mounting screws from the printer as shown at left, and set them aside.

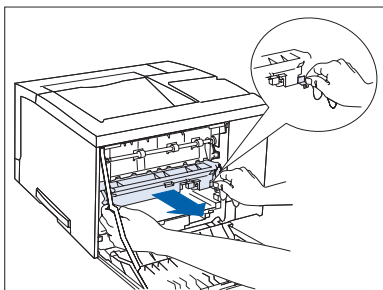

- 6 Pull out the old fuser cartridge by the tabs on either side of the cartridge.

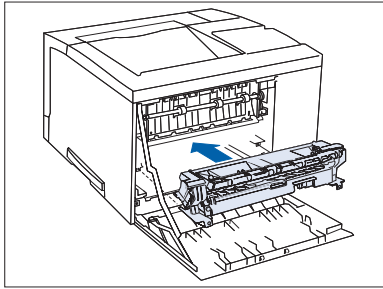

7 Slide the new fuser cartridge into the printer.

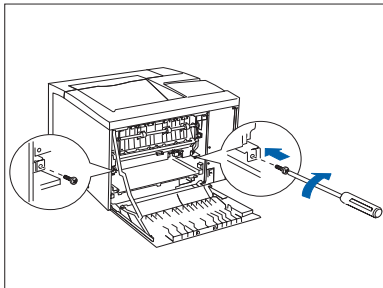

8 Secure the fuser cartridge by replacing the mounting screws that were removed in Step 5 on page 6-6.

If you do not need to re-install the Duplex Module, close the rear cover and skip to Step 11.

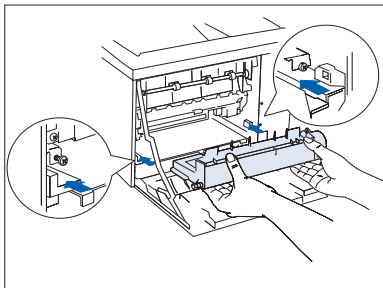

9 Insert the Duplex Module through the guide channels.

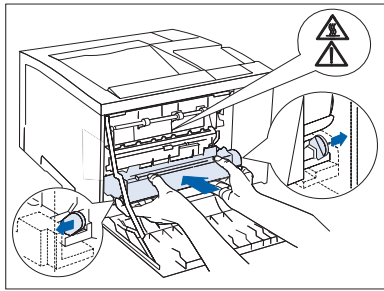

- 10** Make sure the green side-locks at both ends click into position. Then close the rear cover.

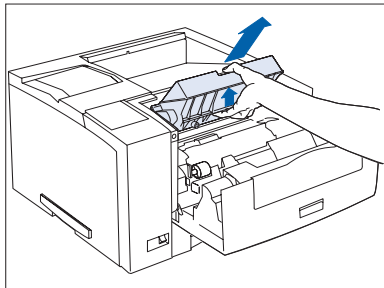

- 11** Open the front cover and remove the EP cartridge by lifting it towards the rear of the printer then pulling it up and out.

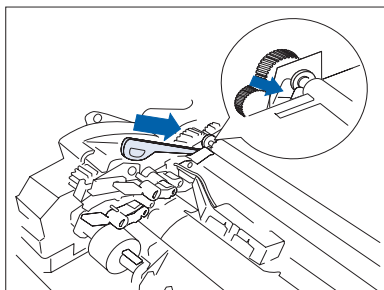

- 12** Use the BTR removal tool to release the left side of the BTR.

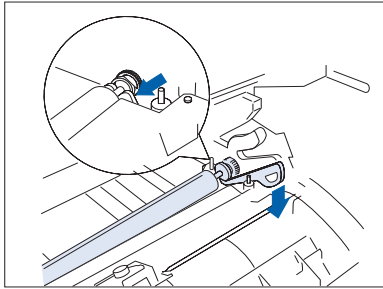

- 13** Use the BTR removal tool to release the right side of the BTR.

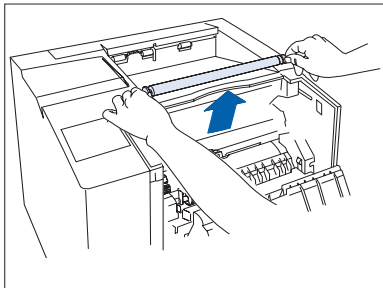

- 14** Lift the BTR out of the printer.

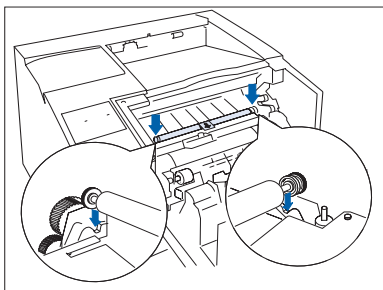

- 15** Insert the new BTR, making sure it is seated properly.

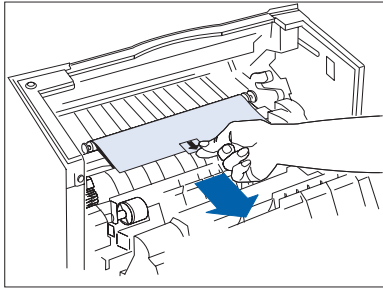

- 16** Pull the tab to remove the BTR's protective covering.

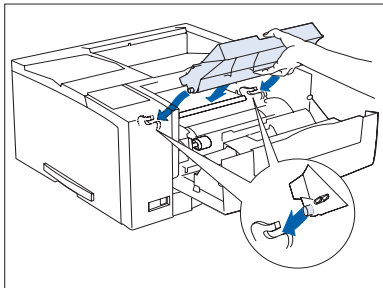

- 17** Re-insert the EP cartridge into the guide channels marked by the arrows inside the top cover. Push in until it clicks in place, then close the front cover.

- 18** Plug in the power cord. Press and hold Online and Menu Down while powering ON the printer. Depress the buttons until a row of black boxes are displayed on the first line of the Control Panel display. This will reset the Fuser Life counter and release the warning message.

After warming up for a few minutes, the Control Panel displays the following message:

Ready

If the **Replace Fuser Cartridge** message still appears, repeat Step 18.

If any other message is displayed, see Table 6.2 on page 6-6.



Troubleshooting

<i>Diagnostic Message Display</i>	<i>7-2</i>
<i>Printer Operation Problems</i>	<i>7-3</i>

Diagnostic Message Display

Chapter 6 of the DocuPrint N17 System Administrator Guide contains the entire set of messages which can appear on the DocuPrint N17 Control Panel display. Many of these messages are diagnostic messages which appear when there is a problem with the DocuPrint N17.

Chapter 6 of the DocuPrint N17 System Administrator Guide also contains a discussion of Print Quality symptoms and possible corrective actions.

If you have a problem with your DocuPrint N17 printer, and you cannot solve the problem using the actions suggested in Table 7.1 on page 7-3 of this guide, consult Chapter 6 of the DocuPrint N17 System Administrator Guide.

Printer Operation Problems

Consult Table 7.1 for corrective actions when the printer will not print or when the printed output is not what you expect.

Table 7.1 Printer operation problems

Problem	Action
<p>The printer will not print at all, or a file sent from the client/server will not print.</p>	<ol style="list-style-type: none"> 1. Check with your network administrator to see that the printer is powered up, connected to the network and that the network is operational. 2. Check Control Panel messages for " Paper Jam," " Door Open," etc. 3. If the port (parallel or network) the printer is connected to is disabled, enable it. Check the Configuration Sheet for the port you are using to see if the Port Enable item in the appropriate Interface Menu is set to <i>On</i>. If it is set to <i>Off</i>, set it to <i>On</i> and try again. 4. If the printer has printed recently, do the following: <ul style="list-style-type: none"> • Attempt to print a Configuration Sheet. If it does not print, contact your dealer or Xerox. • If the Configuration Sheet prints, check to see that the printer is configured properly. • If the printer is configured properly, check the Configuration Sheet to confirm that the correct PDL is enabled for the port or protocol you are using. • If the correct PDL is enabled and the printer continues not to print, contact your dealer or Xerox.

Table 7.1 Page 1 of 4

Table 7.1 Printer operation problems *(continued)*

Problem	Action
<p>A printed page does not look like it should.</p>	<ol style="list-style-type: none"> 1. Make certain that the software application you are using to create your print job is configured properly. Refer to your software documentation. 2. Make sure the correct driver is being used. 3. Send a file containing PCL or PostScript commands to the printer. <ul style="list-style-type: none"> • If your page prints as it should, your printer and interface are functioning properly. • If your information prints correctly, but doesn't look right, you may have: <ul style="list-style-type: none"> - An error in your command sequence/operator. - A missing downloaded font. - A mismatched printer option against your host formatting. • Command errors may be identified by looking at your input file. You can determine which fonts are in the system by printing a PCL or PS Font List. You can verify your data setup by printing a Configuration Sheet and checking your printer setup.
<p>The requested font for the job does not print.</p>	<p>Print a PCL Font List, or PostScript Font List if the job is PostScript.</p> <ul style="list-style-type: none"> • If fonts print on the Font List, your print job may need correcting. • If fonts do not print on the Font List, reload the fonts and print another PCL or PostScript Font List.

Table 7.1 Page 2 of 4

Table 7.1 Printer operation problems (continued)

Problem	Action
PostScript commands are printed instead of the PostScript job.	<ol style="list-style-type: none"> 1. Make certain that the software application you are using to create your job is configured properly. Refer to your software documentation. 2. The job sent to the printer might have included an incorrect header, and therefore, not have indicated that a PostScript job was being sent. <ul style="list-style-type: none"> • Check your software to make sure the PostScript header file is being sent to the printer. 3. Set the Print Errors item in the PostScript Menu to <i>On</i> and resend the job. <ul style="list-style-type: none"> • If an error page prints, there is a problem in the PostScript coding. Correct the coding problem and resend the job. • If the job still does not print and an error page was not printed, the job may require additional memory.

Table 7.1 Page 3 of 4

Table 7.1 Printer operation problems (continued)

Problem	Action
<p>A PostScript or PCL job fails to print.</p>	<ol style="list-style-type: none"> 1. Check that you are using a DocuPrint N17 PostScript printer driver. 2. For a PostScript job, set the Print Errors item in the PostScript Menu to <i>On</i> and resend the job. <ul style="list-style-type: none"> • If an error page prints, there is a problem in the PostScript coding. Correct the coding problem and resend the job. Asking for unavailable features can cause a configuration error. • If the job still does not print and an error page was not printed, the job may require additional memory. See <i>Appendix A of the System Administrator Guide</i> for ordering more printer memory. 3. For a PCL job, do the following: <ul style="list-style-type: none"> • Check the output for PCL errors. • If there is a problem in the PCL coding, correct the coding problem and resend the job. • If there is no error message, resend the job. • If the error message indicates "out of memory," the job may require additional memory. See <i>Appendix A of the System Administrator Guide</i> for ordering more printer memory.
<p>Table 7.1 Page 4 of 4</p>	

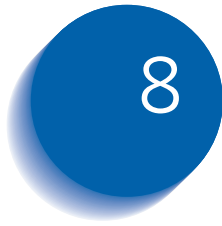

References

Further References

If you need further information over and above what is contained in this Guide, please consult the areas indicated in the following references:

- **Maintenance of the DocuPrint N17**
Chapter 1 and Appendix B of the DocuPrint N17 System Administrator Guide
- **Special DocuPrint N17 Features and Options**
Chapter 1 of the DocuPrint N17 System Administrator Guide
- **Memory Considerations**
Chapter 1 of the DocuPrint N17 System Administrator Guide
- **Extended Paper Handling Capabilities**
Chapter 2 of the DocuPrint N17 System Administrator Guide
- **Use of the DocuPrint N17 Optional Hard Disk Drive and Flash SIMMs**
Chapter 5 of the DocuPrint N17 System Administrator Guide
- **DocuPrint N17 Ordering Information**
Appendix A of the DocuPrint N17 System Administrator Guide
- **DocuPrint N17 Resident Fonts**
Appendix D of the DocuPrint N17 System Administrator Guide
- **Printer Specifications**
Appendix E of the DocuPrint N17 System Administrator Guide

- **DocuPrint N17 Unique Printer Commands**
Appendix F of the DocuPrint N17 System Administrator Guide
- **DocuPrint N17 Environmental Specifics including Safety**
Appendix G of the DocuPrint N17 System Administrator Guide
- **More Detailed Network Environment Technical Information**
The DocuPrint N17 Technical Information Guide (on the DocuPrint N17 CD)
- **DocuPrint N17 Support Information**
The DocuPrint N17 Support Brochure or your warranty booklet
- **Network Installation Information**
The DocuPrint N17 Quick Network Installation Guide
- **DocuPrint N17 CentreWare Information**
The DocuPrint N17 CentreWare Users Guide (on the Printer Management Software CD)
- **DocuPrint N17 System Administrator Guide** (on the DocuPrint N17 CD)
- **Translated Versions of the DocuPrint N17 User Documentation** (on the DocuPrint N17 CD)





CE Declaration

This Appendix contains the “CE Declaration” which only applies to European Countries.

CE ENGLISH

The CE marking applied to this product symbolises Xerox's declaration of conformity with the following applicable directives of the European Union as of the dates indicated.

January 1, 1995 - Council Directive 73/23/EEC amended by Council Directive 93/68/EEC. Approximation of the laws of the member states related to low voltage equipment.

January 1, 1996 - Council Directive 89/336/EEC. Approximation of the laws of the member states related to electromagnetic compatibility.

A full declaration defining the relevant directives and referenced standards can be obtained from your Xerox representative.

WARNING: In order to allow this equipment to operate in proximity to Industrial, Scientific and Medical (ISM) equipment, the external radiation from ISM equipment may have to be limited or special mitigation measures taken.

CE FRANÇAIS

LE SYMBOLE CE FIGURANT SUR CE PRODUIT EST GARANT DE LA CONFORMITE DU MATERIEL XEROX AUX DIRECTIVES DE L'UNION EUROPEENNE ENTRANT EN VIGEUR AUX DATES INDIQUEES.

1er JANVIER 1995 : - Directive du Conseil du 19 février 1973 numéro 73/23/CEE concernant le rapprochement des législations des Etats membres relatives au matériel électrique destiné à être employé dans certaines limites de tension.

1er JANVIER 1996 : - Directive du Conseil du 3 mai 1989 numéro 89/336/CEE concernant le rapprochement des législations des Etats membres relatives à la compatibilité électromagnétique.

LA GARANTIE DE CONFORMITE COMPLETE, AVEC UNE DESCRIPTION DETAILLEE DES DIRECTIVES ET NORMES CONCERNEES, PEUT ETRE OBTENUE SUR SIMPLE DEMANDE AUPRES DE VOTRE COMMERCIAL XEROX.

COMPATIBILITE ELECTROMAGNETIQUE AVERTISSEMENT : Afin de permettre à ce matériel de fonctionner à proximité de matériel ISM, il peut s'avérer nécessaire de réduire le rayonnement émis par ce dernier ou de prendre des mesures spéciales.

CE DEUTSCH

DURCH KENNZEICHNUNG DIESES PRODUKTES MIT DEM CE-ZEICHEN ERKLART SICH XEROX BEREIT, DEN FOLGENDEN DIREKTIVEN DER EUROPÄISCHEN UNION ZU ENTSPRECHEN (MIT WIRKUNG VOM SIEHE DATUM):

1. Januar 1995: - EG-Direktive 73/23/EEC ergänzt durch EG-Direktive 93/68/EEC, Angleichung der Gesetze der einzelnen Mitgliedstaaten bezüglich Geräte mit niedriger Betriebsspannung.

1. Januar 1996: - EG-Direktive 89/336/EEC, Angleichung der Gesetze der einzelnen Mitgliedstaaten bezüglich elektromagnetischer Kompatibilität.

Den vollständigen Text dieser Erklärung einschließlich der Definition der entsprechenden Direktiven sowie der jeweiligen Standards erhalten Sie von Ihrem Xerox Kundendienst.

ELEKTROMAGNETISCHE VERTRÄGLICHKEIT - ACHTUNG: Um eine fehlerfreie Funktion dieses Gerätes in der Umgebung von ISM-Geräten (Hochfrequenzgeräte für industrielle, wissenschaftliche, medizinische und ähnliche Zwecke) zu gewährleisten, ist es erforderlich, daß die Störstrahlung dieser Geräte reduziert oder auf andere Weise begrenzt wird.

CE PORTUGUES

A MARCA CE USADA NESTE PRODUTO, SIMBOLIZA A DECLARAÇÃO DE CONFORMIDADE DA XEROX, COM AS SEGUINTEs DIRECTIVAS APLICAVEIS DA UNIAO EUROPEIA AQUANDO DAS DATAS INDICADAS

1 DE JANEIRO DE 1995: - Directiva 73/23/CEE do Conselho, de 19 de Fevereiro de 1973, relativa à harmonização das legislações dos Estados membros no domínio do material eléctrico destinado a ser utilizado dentro de certos limites de tensão.

1 DE JANEIRO DE 1996: - Directiva 89/336/CEE do Conselho, de 3 de Maio de 1989, relativa à aproximação das legislações dos Estados-membros respeitantes à compatibilidade electromagnética.

Pode pedir ao seu representante Xerox, uma declaração integral definindo as directivas relevantes e padrões referenciados.

COMPATIBILIDADE ELECTROMAGNÉTICA ATENÇÃO: De modo a permitir que este equipamento funcione perto de um equipamento ISM, a adição externa do equipamento ISM poderá ter que ser limitada ou serem tomadas medidas especiais de mitigação.

CE ITALIANO

IL MARCHIO CE APPLICATO A QUESTO PRODOTTO, EQUIVALE A UNA DICHIARAZIONE DI CONFORMITÀ DA PARTE DELLA XEROX RISPETTO ALLE SEGUENTI DIRETTIVE EMESSE DALLA UNIONE EUROPEA ALLE DATE SOTTOINDICATE.

1 GENNAIO 1995: La direttiva 73/23/CEE del Consiglio, del 19 febbraio 1973, concernente il ravvicinamento delle legislazioni degli Stati membri relative al materiale elettrico destinato ad essere adoperato entro taluni limiti di tensione.

1 GENNAIO 1996: La direttiva 89/336/CEE del Consiglio, del 3 maggio 1989, per il ravvicinamento delle legislazioni degli Stati membri relative alla compatibilità elettromagnetica.

LA DICHIARAZIONE COMPLETA, RIPORTANTE LE DIRETTIVE PERTINENTI E GLI STANDARD IVI MENZIONATI, PUÒ ESSERE OTTENUTA PRESSO IL FORNITORE XEROX DI ZONA.

COMPATIBILITÀ ELETTROMAGNETICA AVVERTENZA: Il funzionamento di questo apparecchio in prossimità di apparecchiature ISM rende necessaria la riduzione o la limitazione delle radiazioni emesse da dette apparecchiature.

CE SVENSKA

Ce-märkningen som finns på denna produkt visar Xerox deklARATION vad gäller överensstämmelse med de direktiv som angetts av den europeiska unionen.

1 januari 1995: - eu-direktiv 73/23/eec tillägg till eu-direktiv 93/68/eec, vad gäller närmanden av medlemsländernas lagar beträffande lågspanningsutrustning.

1 januari 1996: - eu-direktiv 89/336/eec, vad gäller närmanden av medlemsländernas lagar beträffande elektromagnetisk kompatibilitet.

Ytterligare beskrivning och definiering av relevanta direktiv och refererade standarder kan erhållas från er Xerox-representant.

ELEKTROMAGNETISK KOMPATIBILITET VARNING: För att denna utrustning ska få arbeta i närheten av en ISM-utrustning så måste den externa strålningen från ISM-utrustningen avgränsas eller nedsättas.

CE HOLLANDS

HET CE-STEMPEL OP DIT PRODUKT SYMBOLISEERT DE CONFORMITEITSVERKLARING VAN XEROX MET DE VOLGENDE VAN TOEPASSING ZIJNDE RICHTLIJNEN VAN DE EU VANAF DE AANGEGEVEN DATA.

1 JANUARI, 1995:- Richtlijn 73/23/EEG van de Raad van 19 februari 1973 betreffende de onderlinge aanpassing van de wettelijke voorschriften der Lid-Staten inzake elektrisch materiaal bestemd voor gebruik binnen bepaalde spanningsgrenzen.

1 JANUARI, 1996:- Richtlijn 89/336/EEG van de Raad van 3 mei 1989 betreffende de onderlinge aanpassing van de wetgevingen van de Lid-Staten inzake de elektromagnetische compatibiliteit.

DE VOLLEDIGE TEKST VAN DEZE VERKLARING, WAARIN DEFINITIES VAN DE RELEVANTE RICHTLIJNEN EN DE RELEVANTE NORMEN, KAN WORDEN VERKREGEN BIJ UW XEROX-LEVERANCIER.

ELEKTROMAGNETISCHE COMPATIBILITEIT
WAARSCHUWING: Om dit apparaat in de nabijheid van industriële, wetenschappelijke en medische (ISM)-apparatuur te laten functioneren, kan het nodig zijn de stoorstraling komende van de ISM-apparatuur te beperken of speciale maatregelen te treffen met het oog op het terugdringen hiervan.

CE ESPAÑOL

EL SÍMBOLO DE LA CE APLICADO A ESTE PRODUCTO SIGNIFICA LA DECLARACIÓN DE XEROX DEL CUMPLIMIENTO DE LAS SIGUIENTES DIRECTIVAS APLICABLES DE LA UNIÓN EUROPEA A PARTIR DE LAS FECHAS INDICADAS.

1 ENERO, 1995:- Directiva 73/23/CEE del Consejo, de 19 de febrero de 1973 (LCEur 1973, 48), sobre el material eléctrico destinado a utilizarse con determinados límites de tensión.

1 ENERO, 1996:- Directiva 89/336/CEE del Consejo, de 3 de mayo de 1989 (LCEur 1989, 628), sobre la aproximación de las legislaciones de los Estados miembros relativas a la compatibilidad electromagnética.

SE PUEDE OBTENER UNA AFIRMACIÓN COMPLETA CON LA DEFINICIÓN DE LAS DIRECTIVAS PERINENETES Y LAS NORMAS DE REFERENCIA PONIÉNDOSE EN CONTACTO CON EL DELEGADO DE XEROX.

COMPATIBILIDAD ELECTROMAGNÉTICA AVISO: Para que este equipo funcione en las inmediaciones de un equipo ISM, tal vez sea preciso limitar la radiación externa del equipo ISM, o adoptar medidas de mitigación especiales.

CE ΕΛΛΗΝΙΚΑ

ΤΟ ΣΥΜΒΟΛΟ CE ΠΟΥ ΥΠΑΡΧΕΙ ΣΕ ΑΥΤΟ ΤΟ ΠΡΟΙΟΝ, ΣΥΜΒΟΛΙΖΕΙ ΤΗ ΔΗΛΩΣΗ ΤΗΣ RANK XEROX ΟΤΙ ΣΥΜΜΟΡΦΟΥΤΑΙ ΜΕ ΤΙΣ ΟΔΗΓΙΕΣ ΤΗΣ ΕΥΡΩΠΑΙΚΗΣ ΕΝΩΣΗΣ ΩΣ ΠΡΟΣ ΤΙΣ ΚΑΤΩΘΙ ΗΜΕΡΟΜΗΝΙΕΣ.

1 ΙΑΝΟΥΑΡΙΟΥ 1995:- ΟΔΗΓΙΑ Νο 73/23/ΕΕΚ ΤΡΟΠΟΠΟΙΗΜΕΝΗ ΑΠΟ ΤΗΝ ΟΔΗΓΙΑ 93/68/ΕΕΚ, ΠΕΡΙ ΣΥΜΜΟΡΦΩΣΗΣ ΜΕ ΤΟΥΣ ΝΟΜΟΥΣ ΤΩΝ ΚΡΑΤΩΝ ΜΕΛΩΝ ΣΧΕΤΙΚΑ ΜΕ ΜΗΧΑΝΗΜΑΤΑ ΧΑΜΗΛΗΣ ΤΑΣΗΣ.

1 ΙΑΝΟΥΑΡΙΟΥ 1996:- ΟΔΗΓΙΑ Νο 89/336/ΕΕΚ, ΠΕΡΙ ΣΥΜΜΟΡΦΩΣΗΣ ΜΕ ΤΟΥΣ ΝΟΜΟΥΣ ΤΩΝ ΚΡΑΤΩΝ ΜΕΛΩΝ ΣΧΕΤΙΚΑ ΜΕ ΤΗΝ ΗΛΕΚΤΡΟΜΑΓΝΗΤΙΚΗ ΣΥΜΒΑΤΟΤΗΤΑ.

ΜΙΑ ΠΛΗΡΗΣ ΔΙΑΚΗΡΥΞΗ ΠΟΥ ΚΑΘΟΡΙΖΕΙ ΤΙΣ ΣΧΕΤΙΚΕΣ ΔΙΑΤΑΞΕΙΣ ΚΑΙΤΑ ΣΧΕΤΙΚΑ ΠΡΟΤΥΠΑ ΜΠΟΡΕΙ ΝΑ ΖΗΤΗΘΕΙ ΑΠΟ ΤΟΝ ΑΝΤΙΠΡΟΣΩΠΟ ΤΗΣ RANK XEROX.

ΕΛΕΚΤΡΟΜΑΓΝΗΤΙΚΗ ΣΥΜΒΑΤΟΤΗΤΑ ΠΡΟΣΟΧΗ: Για να επιτραπεί η λειτουργία του μηχανήματος άσει των προδιαγραφών ISM, η εκπομπή ραδιοσυχνοτήτων θα πρέπει να μειωθεί ή να παρθούν ειδικά μέτρα περιορισμού της.

CE SUOMI

Tässä tuotteessa oleva CE- eli vaatimustenmukaisuusmerkintä osoittaa, että Xerox on sitoutunut noudattamaan seuraavia EU-direktiivejä mainitusta päivämäärästä lähtien.

Tammikuun 1. päivä, 1995: Neuvoston direktiivi 73/23/ETY ja sen muutos 93/68/ETY tietyllä jänniteluella toimivia sähkölaitteita koskevan jäsenvaltioiden lainsäädännön lähentämistä.

Tammikuun 1. päivä, 1995:- Neuvoston direktiivi 89/336/ETY sähkömagneettista yhteensopivuutta koskevan jäsenvaltioiden lainsäädännön lähentämistä.

Täydelliset tiedot asianomaisista direktiiveista ja standardeista on saatavissa Xeroxilta.

SÄHKÖMAGNEETTINEN YHTEENSOPIVUUS VAROITUS: Jotta tämä laite voisi toimia ISM-laitteen (teolliset, tieteelliset ja lääketieteelliset laitteet) läheisyydessä, ISM-laitteen ulkoista säteilyä pitää ehkä rajoittaa tai lieventäviä erikoistoimia toteuttaa.

CE DANSK

CE MÆRKET ANGIVER, AT DETTE XEROX PRODUKT OPFYLDER KRAVENE I NEDENSTÅENDE EF DIREKTIVER AF NÆVNTE DATOER.

1. JANUAR 1995:- Rådets direktiv 73/23/EOF af 19. februar 1973 om tilnærmelse af medlemsstaternes lovgivning om elektrisk materiel bestemt til anvendelse inden for visse spændingsgrænser.

1. JANUAR 1996:- Rådets direktiv 89/336/EOF af 3. maj 1989 om indbyrdes tilnærmelse af medlemsstaternes lovgivning om elektromagnetisk kompatibilitet.

RING TIL XEROX TEKNISK SERVICE, HVIS DE ØNSKER EN LISTE OVER RELEVANTE EF DIREKTIVER OG STANDARDER.

ELEKTROMAGNETISK KOMPATIBILITET ADVARSEL: For at dette udstyr kan anvendes i umiddelbar nærhed af ISM udstyr, skal udstrålingen fra ISM udstyr begrænses eller der skal laves specielle begrænsende anordninger.





Index

Numerics

500-sheet Paper Deck and
Cassette
Loading 4-14 to 4-16

B

Bias Transfer Roll
Replacing 6-5 to 6-10

C

CentreWare DP 2-2
Control Panel 3-2 to 3-4
Display 3-3

D

Drivers, see Printer drivers
Duplex Module
Acceptable paper sizes 4-4,
4-24
Acceptable paper weights 4-2
Using 4-24 to 4-25
Duplex printing 4-24 to 4-25
Paper orientation 4-25

E

Envelope Feeder

Acceptable envelope sizes
4-4

Loading 4-20 to 4-21

Envelopes

Acceptable sizes 4-4

Loading

In Envelope Feeder 4-20 to
4-21

In MBF 4-9 to 4-13

EP Cartridge

Replacing 6-2 to 6-4

F

Fuser Cartridge

Replacing 6-5 to 6-10

H

HCF

Acceptable paper weights 4-2
Loading 4-17 to 4-19

High Capacity Feeder, see HCF

L

Labels

Acceptable sizes 4-4

Loading, see Paper loading

M

M

MBF

- Acceptable paper sizes 4-4
- Acceptable paper weights 4-2
- Loading 4-9 to 4-13

O

OCT

- Acceptable paper sizes 4-4

P

Paper

- Acceptable sizes 4-4
- Acceptable weights 4-2
- Jams 5-2 to 5-19
 - Causes 5-2
 - Clearing 5-3 to 5-19
 - Control Panel messages 5-4 to 5-6
- Loading 4-6 to 4-21
 - In 500-sheet Paper Deck and Cassette 4-14 to 4-16
 - In HCF 4-17 to 4-19
 - In MBF 4-9 to 4-13
 - In Tray 1 4-6 to 4-8
- Selecting for use 4-2
- Specifying size of 4-23
- Specifying type of 4-23
- Storage of 4-5
- Unacceptable for use 4-2

PCL

- Printer drivers 2-3

PostScript

- Printer drivers 2-4

Printer drivers

- Features 2-5 to 2-6
- PCL 2-3
- PostScript 2-4

S

Standard Bin

- Acceptable paper sizes 4-4

T

Transparencies

- Acceptable sizes 4-4
- Loading, see Paper loading

Tray 1

- Acceptable paper sizes 4-4
- Acceptable paper weights 4-2
- Loading 4-6 to 4-8

Tray 2

- Acceptable paper sizes 4-4
- Acceptable paper weights 4-2

Tray 3

- Acceptable paper sizes 4-4
- Acceptable paper weights 4-2

Tray Sequence 4-22

Tray switching 4-22

- Also see Tray Sequence

Troubleshooting

- Printer operation problems 7-3 to 7-6

Free Manuals Download Website

<http://myh66.com>

<http://usermanuals.us>

<http://www.somanuals.com>

<http://www.4manuals.cc>

<http://www.manual-lib.com>

<http://www.404manual.com>

<http://www.luxmanual.com>

<http://aubethermostatmanual.com>

Golf course search by state

<http://golfingnear.com>

Email search by domain

<http://emailbydomain.com>

Auto manuals search

<http://auto.somanuals.com>

TV manuals search

<http://tv.somanuals.com>