

*Sunbeam*



# Snack Heroes™

## Ice Cream Maker

Instruction Booklet  
GL5500

Please read these instructions carefully  
and retain for future reference.



# Contents

<b>Sunbeam's Safety Precautions</b>	<b>1</b>
<b>Features of your Snack Heroes™ Ice Cream Maker</b>	<b>2</b>
<b>Before using your Snack Heroes™ Ice Cream Maker</b>	<b>4</b>
<b>Using your Snack Heroes™ Ice Cream Maker</b>	<b>5</b>
<b>Handy hints when using your Snack Heroes™ Ice Cream Maker</b>	<b>7</b>
<b>Tips to Making Custard Based Ice Cream</b>	<b>8</b>
<b>Care and Cleaning</b>	<b>9</b>
<b>Recipes</b>	<b>10</b>

## Important instructions – retain for future use.

تأكد من تفهم احتياطات السلامة المذكورة اعلاه

請務必理解上述的安全預防措施。

Assurez-vous que les précautions ci-dessus relatives à la sécurité sont bien comprises

Versichern Sie sich, dass die obenstehenden Sicherheitsmaßnahmen verstanden werden

Βεβαιώνετε πως οι παραπάνω προφυλάξεις ασφαλείας γίνονται κατανοητές

Pastikan bahwa tindakan-tindakan keselamatan seperti di atas dimengerti anda

Accertatevi che le suddette norme di sicurezza siano comprese a dovere

上記の注意事項をよくお読みになり、安全を御確認ください

Уверете се дека погоре споменатите мерки на претпазливост се добро разбрани

Asegúrese de que las precauciones de seguridad precedentes sean bien comprendidas

کاری بکنید کہ احتیاط‌های بالا حتماً درک بشوند

ต้องแน่ใจว่า ข้อควรระวังเรื่องความปลอดภัยข้างต้น เป็นที่เข้าใจกันดี

Yukarda belirtilen güvenlik önlemlerinin anlaşılığundan emin olunuz

Xin kiểm chắc rằng những biện pháp làm an toàn kể trên được hiểu rõ

# Sunbeam's Safety Precautions

## SAFETY PRECAUTIONS FOR SNACK HEROES™ ICE CREAM MAKER

- This appliance is not a toy.
- Always operate on a flat surface.

---

**Sunbeam is very safety conscious when designing and manufacturing consumer products, but it is essential that the product user also exercise care when using an electrical appliance. Listed below are precautions which are essential for the safe use of an electrical appliance:**

- Read carefully and save all the instructions provided with an appliance.
- Always turn the power off at the power outlet before you insert or remove a plug. Remove by grasping the plug - do not pull on the cord.
- Turn the power off and remove the plug when the appliance is not in use and before cleaning.
- Do not use your appliance with an extension cord unless this cord has been checked and tested by a qualified technician or service person.
- Always use your appliance from a power outlet of the voltage (A.C. only) marked on the appliance.
- This appliance is not intended for use by persons (including children) with reduced physical, sensory or mental capabilities, or lack of experience and knowledge, unless they have been given supervision or instruction concerning use of the appliance by a person responsible for their safety.
- Children should be supervised to ensure that they do not play with the appliance.
- The temperature of accessible surfaces may be high when the appliance is operating.
- Do not place freezer canister or motor unit in a dishwasher.
- Do not place motor unit in the freezer.
- Never leave an appliance unattended while in use.
- Do not use an appliance for any purpose other than its intended use.
- Do not place an appliance on or near a hot gas flame, electric element or on a heated oven.
- Do not place on top of any other appliance.
- Do not let the power cord of an appliance hang over the edge of a table or bench top or touch any hot surface.
- Do not operate any electrical appliance with a damaged cord or after the appliance has been damaged in any manner. If damage is suspected, return the appliance to the nearest Sunbeam Appointed Service Centre for examination, repair or adjustment.
- For additional protection, Sunbeam recommend the use of a residual current device (RCD) with a tripping current not exceeding 30mA in the electrical circuit supplying power to your appliances.
- Do not immerse the appliance in water or any other liquid unless recommended.
- Appliances are not intended to be operated by means of an external timer or separate remote control system.
- This appliance is intended to be used in household and similar applications such as: staff kitchen areas in shops, offices and other working environments; farm houses; by clients in hotels, motels and other residential type environments; bed and breakfast type environments.

If you have any concerns regarding the performance and use of your appliance, please visit [www.sunbeam.com.au](http://www.sunbeam.com.au) or contact the Sunbeam Consumer Service Line.

Ensure the above safety precautions are understood.

# Features of your Snack Heroes™ Ice Cream Maker

## **On/Off switch**

Indicates when the unit is switched on.

## **Motor unit**

Rotates the paddle.

## **Pouring hole cover**

Enables easy pouring of ingredients during the freezing process and its transparency allows observation of the ice cream making process for perfect results every time. Pouring hole cover holds the motor unit in place.

## **Paddle extender**

Connects the paddle to motor unit.

## **Paddle**

Churns mixture until the right consistency is achieved.

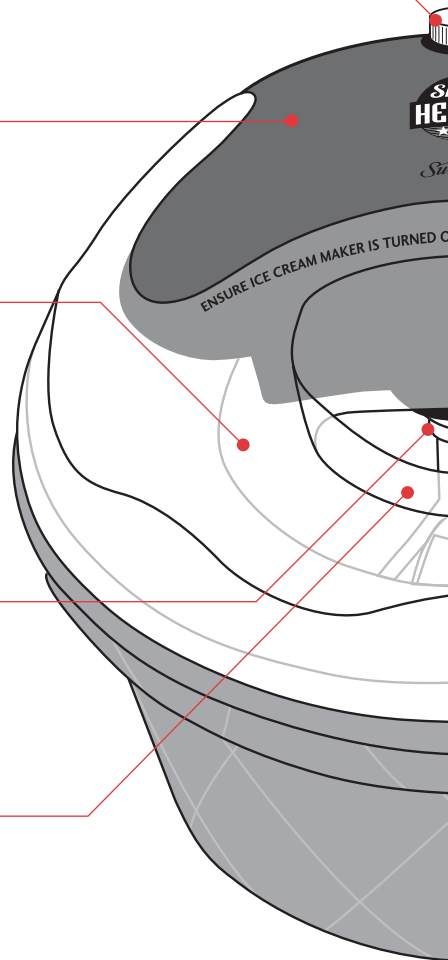

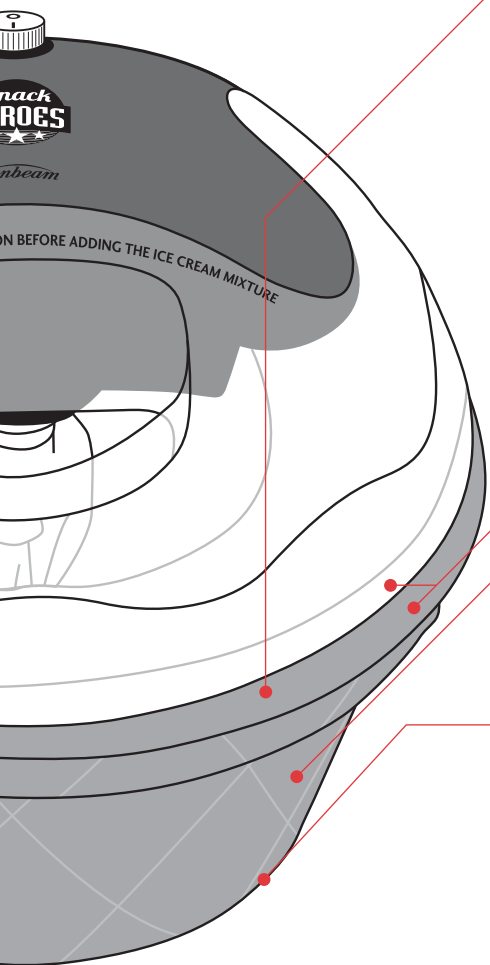

**Freezer canister**

The freezer canister has been specially designed to freeze quickly in your freezer and provide an even temperature throughout the freezing process.

**Locking Tabs**

Holds the pouring hole cover and base in place.

**Base**

Holds the freezer canister.

**Non-slip rubber feet**

Non-slip rubber feet provide extra stability.

# Before using your Snack Heroes™ Ice Cream Maker

1. Before using your ice cream maker for the first time, ensure that all packing material is removed.
2. Remove the motor base from the pouring hole cover. Wash the freezer canister, paddle, pouring hole cover and base in warm soapy water. Be sure to rinse and dry all parts thoroughly. Wipe the motor unit with a damp cloth.

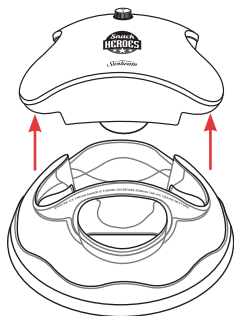

3. It is important when making ice cream that the freezer canister is properly frozen. The ice cream maker features a double insulated bowl which requires thorough freezing. For best results wrap the freezer canister in a plastic bag and place upright in the back of the freezer, where it is coldest. Wrapping the freezer canister with a plastic bag will prevent odours from within the freezer seeping into the freezer canister. As there is liquid in between the canister walls, shake the canister to check if fully frozen; you should not hear any liquid moving within the walls.

**NOTE:** Continually storing the freezer canister in the freezer allows you the flexibility to make your favourite ice cream at a moment's notice.

---

**AVERAGE FREEZER  
TEMPERATURE**

-18°C

**APPROXIMATE  
FREEZING TIME**

20-22 hrs

**NOTE:** The freezer temperature may vary depending on how many times it is opened throughout the day.

# Using your Snack Heroes™ Ice Cream Maker

1. Slide the motor unit onto the pouring hole cover until it locks in place. Two tabs underneath will 'click' into place.

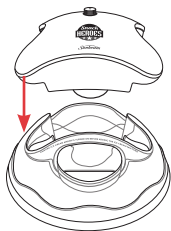

2. Insert the paddle extender into the motor unit opening.

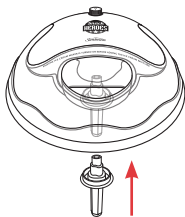

3. Connect the paddle to the paddle extender.

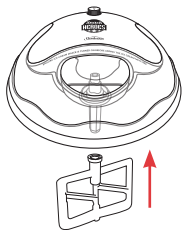

4. Remove the freezer canister from freezer.

5. Place the freezer canister into the base.

6. Place the pouring hole cover onto the base so that all 4 locking tabs are aligned.

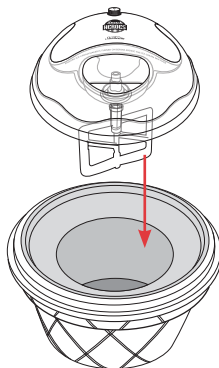

7. Rotate clockwise slightly until the tabs lock into place.

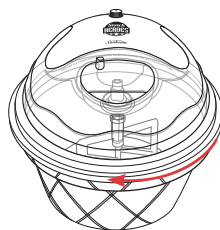

8. Insert the plug into the power outlet and turn the ice cream maker on immediately. This will prevent the paddle from freezing onto the freezer canister.

9. Pour the prepared ice cream mixture through the pouring hole into the freezer canister.

## Using your Snack Heroes™ Ice Cream Maker (continued)

**NOTE:** It is extremely important that the freezer canister is used immediately after it is removed from the freezer as it begins to thaw once removed. Ensure the ice cream mixture is ready and well chilled, then remove the freezer canister from the freezer.

10. The ice cream maker process will take anywhere from 20-40 minutes. Do not turn appliance off during use as the mixture may freeze and prevent movement of the paddle.

**NOTE:** If after 40 minutes the mixture is not yet solid or has thawed again, do not continue. Possible reasons for the mixture not freezing include: the freezer canister was not cold, the mixture was too warm, room temperature is quite warm or the proportion of the ingredients were incorrect.

11. To add ingredients after the mixture process has begun, gently add them through the pouring hole.

12. When the mixture has thickened and reaches the top of the paddle, the ice cream is completely prepared and the ice cream maker should be turned off. To avoid the motor overheating, the ice cream maker may turn itself off when the mixture has thickened and is ready.

13. Remove the paddle from the mixture.

14. Allow the mixture to sit in the freezer canister for 5 minutes before serving. Only use plastic, rubber or wooden utensils to serve from the freezer canister. Metal spoons may damage the bowl.

**NOTE:** At this stage your ice cream will be a spoonable consistency.

15. To further harden the mixture, transfer your ice cream into a clean, covered airtight container and place in the freezer.



# Handy Hints when using your Snack Heroes™ Ice Cream Maker

- The time taken to make ice cream will depend on the ambient temperature of a room, how long the freezer canister has been freezing, the temperature of the freezer and the temperature of the ingredients added to the ice cream maker. As a general rule, the cooler these elements, the faster the ice cream making process. The churning process will take anywhere from 20-40 minutes based on this.
- When following recipes that require the mixture to be pre-cooked, it is best to prepare the mixture a day in advance to allow maximum chilling time.
- When preparing ice cream mixtures that do not require pre-cooking, we recommend using an electric mixer for maximum aeration, then making sure mixture is very cold before churning.
- The consistency of the ice cream/sorbets should be a spoonable consistency when finished. We recommend however, transferring your ice cream to a container and placing in the freezer for a further 1-2 hours for a firm ice cream.
- Foods such as cream, sugar, eggs and milk are often the key ingredients in an ice cream mixture. They may be substituted with similar ingredients to suit your taste and dietary requirements. For example, different varieties of cream may be used, which will produce varying flavours and textures.
- Due to an increase in volume during preparation, the maximum amount of liquid mixture should not exceed 850ml. If using your own recipes, adapt the volume of mixture to these amounts. 850ml of mixture will create approximately 1 litre of ice cream; however sorbets do not expand as much therefore making a smaller quantity.
- Alcohol inhibits the freezing process. If adding alcohol to a recipe, add when the mixture is almost frozen. The best way to judge this is when the mixture reaches the top of the paddle.
- Be aware that flavours of fruit based sorbets and ice creams may vary depending on the ripeness and sweetness of fruit or juice used.
- You can replace sugar with an artificial sweetener. We recommend using one that is in equal proportion (spoon to spoon) to sugar, such as Equal or sweeteners that suggest using half the amount of sugar such as CSR Smart sugar.
- When storing your ice cream, ensure the container is no larger than 1 litre and well sealed. Placing a piece of baking paper over the ice cream will prevent ice crystals from forming on the ice cream.
- Ice cream is best consumed within 2 weeks.
- When serving ice cream straight from the freezer, allow the ice cream to sit out at room temperature for 5-10 minutes; this will make serving easier.

# Tips to Making Custard Based Ice Cream

A traditional creamy ice-cream is made from a custard base. Here are some steps to help you achieve perfect custard every time.

- Make sure the eggs are fresh and are at room temperature.
- Have your ingredients measured out and ready so that you are not leaving anything waiting.
- Using a wire whisk or electric hand mixer, beat the egg yolks and sugar in a large deep bowl for about 3-4 minutes or until light and creamy. The colour will go quite light.
- Place the milk/cream required for the recipe in a saucepan.
- Heat the milk mixture on a low/medium heat until the mixture looks like it is almost about to boil. A good guide is when little bubbles start to appear around the edges of the milk. Be careful not to boil. Should you boil the milk you will need to start again.
- Using a wire whisk, whisk the hot milk mixture gradually into the egg mixture making sure that the two are well combined.
- Return the mixture into a clean saucepan and cook over a low heat, stirring constantly with a wooden spoon. The custard mixture is ready when it thickens and coats the back of a spoon. To test this place the wooden spoon into the custard mixture then turn the spoon over. Run your finger once down the back of the spoon. If the custard is thick enough it will keep the finger mark, if it is still runny the mixture will either not grab onto the back of the spoon and look very thin or the finger mark will not stay.
- If the mixture separates or curdles then heat is too high.
- Do not leave the custard unattended while cooking.
- The custard will take anywhere from 5-15 minutes to thicken depending on the type/size of saucepan used. It is best to use a low heat as different stove types will vary greatly in heat.
- Once the custard has thickened, transfer the mixture into a heat proof bowl. Allow the mixture to cool before placing into the refrigerator, cover and chill for several hours before use.

# Care & Cleaning

- Always turn the power off and remove the plug from the power outlet after use and before cleaning.
- Wash the freezer canister in warm soapy water. This can be done if the unit is still partially frozen; it will not damage or crack the unit. However, if the unit is still partially frozen you must dry immediately as the water will start to freeze inside the unit. Be sure to rinse and dry thoroughly. Do not use abrasive scouring pads, powders or cleaners.

**NOTE:** Never place the freezer canister in the freezer if it is still wet.

- Pouring hole cover, paddle and base may be placed on the top shelf of the dishwasher.

**NOTE:** Never place the freezer canister in the dishwasher.

- The motor unit should be cleaned by using a damp cloth.

**NOTE:** Never immerse motor unit in water.

- Do not use sharp objects or utensils inside the freezer canister. Sharp objects will scratch and damage the inside of the freezer canister. A plastic, wooden or rubber spoon, or spatula, may be used when the appliance is in the 'OFF' position.

# Recipes

## **Basic Vanilla Ice Cream 1**

**Makes 1 litre**

Cooking & Prep time:

20 minutes + chilling time

1 cup (250ml) milk

2 cups (500ml) thickened cream

1 vanilla bean, seeds scraped\*

5 egg yolks

½ cup (110g) caster sugar

1. Combine milk and cream in a saucepan. Split vanilla bean in half lengthways. Scrape out the seeds; add the pod and the seeds to the saucepan. Bring the mixture to simmering point over low heat.
2. Whisk egg yolks and sugar together for 3-4 minutes, until light and creamy.
3. Gradually whisk in hot milk mixture into yolk mixture until well combined.
4. Return the mixture into a clean saucepan and cook, stirring constantly with a wooden spoon, over low heat until mixture thickens and coats the back of the spoon.

**Tip:** For further tips on custard making see page 8.

5. Transfer mixture to a bowl and remove vanilla pod. Allow to cool before placing in the fridge to chill for 4-6 hours or until very cold.
6. Position the ice cream maker as directed on pages 5-6. Turn unit on; add mixture through the pouring hole..
7. When mixture has thickened and reaches the top of the paddle, the ice cream is completely prepared and the ice cream maker should be turned off. To avoid the motor overheating, the ice cream maker may turn itself off when the mixture has thickened and is ready.

\* Vanilla bean can be substituted with 2 teaspoons of vanilla essence

## **Variations to this recipe:**

### **Chocolate Ice Cream**

**Makes approx. 1 litre**

Cooking & Prep time:

20 minutes + chilling time

1 quantity basic vanilla ice cream 1

150g chopped dark chocolate

1. Follow steps 1-7 for basic vanilla ice cream 1, heating the dark chocolate with the cream and milk.
2. Omit vanilla bean.

### **Rum & Raisin Ice Cream**

**Makes approx. 1 litre**

Cooking & Prep time:

40 minutes + chilling time

1 quantity basic vanilla ice cream 1

⅓ cup (55g) chopped raisins

1 tablespoons dark rum

1. Soak chopped raisins with rum for 1 hour before churning.
2. Follow steps 1-7 for basic vanilla ice cream 1. Omit vanilla bean.
3. Position the Frozen dessert maker as directed on pages 7-8. Turn unit on; add basic vanilla ice cream mixture through the pouring hole.
4. Once mixture has reached the top of the paddle, pour in the soaked raisins and rum. Churn for a further 5 minutes or until the ice cream maker turns itself off.

## Recipes (continued)

### **Peppermint Choc Chip Ice Cream**

**Makes approx. 1 litre**

Cooking & Prep time:

25 minutes + chilling time

- 1 quantity basic vanilla ice cream 1
- 1 teaspoon peppermint essence
- 55g finely chopped dark chocolate
- green food colouring (optional)

1. Follow steps 1-7 for basic vanilla ice cream  
1. Omit vanilla bean.
2. Add peppermint essence to mixture before churning.
3. Add finely chopped chocolate and food colouring to the custard mixture through the pouring hole when churning.

### **Basic Vanilla Ice Cream 2** Makes approx. 800ml

Cooking & Prep time:

25 minutes + chilling time

- 1 cup (250ml) milk
- 1 cup (250ml) thickened cream
- 1 Vanilla Bean\*
- 4 egg yolks
- ½ cup (110g) caster sugar

1. Combine milk and cream in a saucepan. Split vanilla bean in half lengthways. Scrape out the seeds and add the pod and the seeds to the saucepan. Bring the mixture to simmering point over low heat.
2. Whisk egg yolks and sugar together for 3-4 minutes, until light and creamy.
3. Gradually whisk in hot milk mixture into yolk mixture until well combined.
4. Return the mixture into a clean saucepan and cook, stirring constantly with a wooden spoon, over low heat until mixture thickens and coats the back of the spoon. Do not allow mixture to boil or it will curdle.

5. Transfer mixture to a bowl and remove vanilla pod. Allow to cool before placing in the fridge for 4-6 hours or until very cold.

**Tip:** For further tips on custard making see page 8.

6. Position the ice cream maker as directed on pages 5-6. Turn unit on; add mixture through the pouring hole.

7. When mixture has thickened and reaches the top of the paddle, the ice cream is completely prepared and the ice cream maker should be turned off. To avoid the motor overheating, the ice cream maker may turn itself off when the mixture has thickened and is ready.

\* Vanilla bean can be substituted with 2 teaspoons of vanilla essence

### *Variations to this recipe:*

#### **White Chocolate Ice Cream**

**Makes approx. 1 litre**

Cooking & Prep time:

30 minutes + chilling time

- 1 quantity basic vanilla ice cream 2
- 150g chopped white chocolate
- 50g finely chopped white chocolate, extra

1. Follow steps 1-7 for basic vanilla ice cream 2, heating the white chocolate with the cream and milk. Omit vanilla bean.
2. Add finely chopped chocolate to the custard mixture through the pouring hole when churning.

## Recipes (continued)

### **Coffee Ice Cream**                      **Makes approx. 850ml**

Cooking & Prep time:

20 minutes + chilling time

1 quantity basic vanilla ice cream 2

60ml strong fresh espresso\*

1. Follow steps 1-7 for basic vanilla ice cream 2, heating the coffee with the cream and milk.

2. Omit vanilla bean.

\* Fresh espresso can be substituted with 2 teaspoons of instant coffee dissolved in 1 tablespoon of water

### **Peanut Butter Brittle**                      **Makes approx. 1 litre**

Cooking & Prep time:

40 minutes + chilling time

1 quantity basic vanilla ice cream 2

¼ cup crunchy peanut butter

1 cup (220g) caster sugar

¼ cup water

¼ cup roasted, salted peanuts, chopped

1. Follow steps 1-7 for basic vanilla ice cream 2, heating the peanut butter in with the milk and cream.

2. Meanwhile, combine sugar and water in a small heavy-based saucepan; stir over low heat until sugar dissolves. Increase heat; boil, uncovered, without stirring, about 10 minutes or until syrup is a deep golden colour.

3. Pour toffee mixture into a 20cm x 20cm square pan; stand 5 minutes. Sprinkle peanuts over toffee. Refrigerate for approximately 20 minutes or until set. Break praline into shards; pulse in a food processor until coarsely chopped.

4. Once the ice cream is finished, stir through 1 cup of the praline. Spoon into

a plastic container; cover and freeze until firm. Sprinkle remaining praline mixture over the ice cream before serving.

### **Cookies and Cream**                      **Makes approx. 1 litre**

Cooking & Prep time:

20 minutes + chilling time

1 quantity basic vanilla ice cream 2

150g Oreo cookies, roughly chopped

1. Follow steps 1-7 for basic vanilla ice cream 2.

2. Add Oreo cookies in step 5 after custard mixture is cold.

### **Choc Hazelnut Ice Cream**                      **Makes approx. 900ml**

Cooking & Prep time:

30 minutes + chilling time

1 quantity basic vanilla ice cream 2

⅓ cup chocolate hazelnut spread

5 Ferrero Rocher chocolates

1. Follow steps 1-7 for basic vanilla ice cream 2, heating the hazelnut spread with the cream and milk. Omit vanilla bean.

2. Place chocolates into a small clean plastic bag and crush with a mallet or rolling pin.

3. Add to the custard mixture through the pouring hole when churning.

### **Easy Mix Vanilla Ice Cream**                      **Makes approx. 1 litre**

Cooking & Prep time:

40 minutes + chilling time

1½ cups (375 ml) milk

200g condensed milk

¾ cup (180ml) cream

1 teaspoon vanilla essence

1. Combine milk, condensed milk, cream and vanilla essence together in a bowl; mix well.

## Recipes (continued)

2. Refrigerate mixture until completely chilled.
3. Position the ice cream maker as directed on pages 5-6. Turn unit on; add mixture through the pouring hole.
4. When mixture has thickened and reaches the top of the paddle, the ice cream is completely prepared and the ice cream maker should be turned off. To avoid the motor overheating, the ice cream maker may turn itself off when the mixture has thickened and is ready.

### **Variations to this recipe: (Easy Mix Vanilla)**

#### **Choc-Honey Comb**

#### **Praline Ice Cream      Makes approx. 1.25 litres**

Cooking & Prep time:

20 minutes + chilling time

- 1 quantity easy mix vanilla ice cream
- 1 cup (220g) caster sugar
- ½ cup (125ml) water
- ½ cup (100g) honey comb chocolate
- ⅓ cup (75gm) honey comb, chopped

1. Follow steps 1-4 for easy mix vanilla ice cream.
2. Meanwhile, combine sugar and water in a small heavy-based saucepan; stir over low heat until sugar dissolves. Increase heat; boil, uncovered, without stirring, about 10 minutes or until syrup is a deep golden colour.
3. Pour toffee mixture into a 20cm x 20cm square pan; stand for 5 minutes. Sprinkle honey comb chocolate over hot toffee. Refrigerate for approximately 20 minutes or until set. Break praline into shards; pulse in a food processor until coarsely chopped.

4. Once the ice cream is finished stir through 1 cup of the honey comb praline mixture; stir to combine. Spoon into a plastic container; cover and freeze until firm.

**Tip:** The basic vanilla ice cream recipes can also be used for this recipe.

#### **Rocky Road Ice Cream      Makes approx. 1.2 litres**

Cooking & Prep time:

20 minutes + chilling time

- 1 quantity easy mix vanilla ice cream
- 1 cup (50g) mini marshmallows
- 100g dark chocolate, chopped coarsely
- ⅓ cup shredded coconut, toasted

1. Follow steps 1-4 for easy mix vanilla ice cream.
2. Combine marshmallow, chocolate, coconut in a large bowl.
3. Once the ice cream is finished stir through the marshmallow mixture. Spoon into a plastic container; cover and freeze until firm.

**Tip:** The basic vanilla ice cream recipes can also be used for this recipe.

## Recipes (continued)

### Low Fat Vanilla Ice Cream

Makes approx. 750ml (630g)

Cooking & Prep time:  
25 minutes + chilling time

- 1½ teaspoons gelatine
- 2 tablespoons water
- 400ml skim milk
- 100ml thickened light cream 18% milk fat
- ¼ cup (55g) caster sugar
- 2 teaspoons vanilla essence

1. Mix gelatine with boiling water and stir until dissolved.
2. Combine milk, cream, sugar and vanilla in a saucepan. Bring the mixture to simmering point over low heat; stirring occasionally until sugar dissolves.
3. Remove from heat and add the gelatine mixture; mix well.
4. Refrigerate until completely chilled.
5. Position the ice cream maker as directed on pages 5-6. Turn unit on; add mixture through the pouring hole.
6. When mixture has thickened and reaches the top of the paddle, the ice cream is completely prepared and the ice cream maker should be turned off. To avoid the motor overheating, the ice cream maker may turn itself off when the mixture has thickened and is ready

*Nutritional information per 100g*

397kj; 3.1g total fat; 2g sat fat; 3.9g protein; 13g carbohydrates; 13g sugars

### Variations to this recipe:

#### Low Fat Chocolate Ice Cream

Makes approx. 750ml (685g)

Cooking & Prep time:  
20 minutes + chilling time

- 1 quantity low fat vanilla ice cream
- ¼ cup (30g) cocoa powder
- ¼ cup (55g) caster sugar

1. Follow steps 1-6 for low fat vanilla ice cream, gently whisking the cocoa powder and sugar into the hot milk until dissolved.

*Nutritional information per 100g*

560kj; 3.4g total fat; 2.2g sat fat; 4.4g protein; 21g carbohydrates; 20g sugars



## Recipes (continued)

### Low Fat Strawberry Ice Cream

Makes approx. 1 litre (1180g)

Cooking & Prep time:

40 minutes + chilling time

1 quantity low fat vanilla ice cream

500g strawberries, hulled

¼ cup (55g) caster sugar

1. Follow steps 1-6 for low fat vanilla ice cream adding strawberry mixture in step 5.
2. To make strawberry mixture, process strawberries in a food processor until smooth. Press mixture through a fine sieve; discard seeds.
3. Place strawberry puree and extra sugar in a saucepan and stir over a low heat until the sugar has dissolved. Increase heat and boil, stirring occasionally, for about 8 minutes or until the mixture has reduced to 1 cup. Transfer to a heatproof bowl or jug; chill for several hours.
4. Combine the ice cream mixture and strawberry mixture in a jug.

*Nutritional information per 100g*

326kj; 1.7g total fat; 1.1g sat fat; 2.8 protein; 13g carbohydrates; 13g sugars

### Reduced Fat Basic Vanilla Ice cream

Makes 1 litre (1000g)

Cooking & Prep time:

40 minutes + chilling time

*This recipe is 40% less fat than our original basic vanilla ice cream 1 recipe on page 10*

1 cup (250ml) skim milk

2 cups (500ml) thickened light cream

18% milk fat

1 vanilla bean, seeds scraped\*

5 egg yolks

½ cup (110g) caster sugar

1. Combine milk and cream in a saucepan. Split vanilla bean in half lengthways. Scrape out the seeds; add the pod and the seeds to the saucepan. Bring the mixture to simmering point over low heat.
2. Whisk egg yolks and sugar together for 3-4 minutes, until light and creamy.
3. Gradually whisk in hot milk mixture into yolk mixture until well combined.
4. Return the mixture into a clean saucepan and cook, stirring constantly with a wooden spoon, over low heat until mixture thickens and coats the back of the spoon.

**Tip:** For further tips on custard making see page 8.

5. Transfer mixture to a bowl and remove vanilla pod. Allow to cool before placing in the fridge to chill for 4-6 hours or until well chilled.
6. Position the ice cream maker as directed on pages 5-6. Turn unit on; add mixture through the pouring hole.
7. When mixture has thickened and reaches the top of the paddle, the ice cream is completely prepared and the ice cream maker should be turned off. To avoid the motor overheating, the ice cream maker may turn itself off when the mixture has thickened and is ready.

\*Vanilla bean can be substituted with 2 teaspoons of vanilla essence

*Nutritional information per 100g*

787kj; 12.5g total fat; 7.4g sat fat; 4.7g protein; 15g carbohydrates; 15g sugars

## Recipes (continued)

### No Added Sugar Ice Cream

**Makes approx 1 litre (740g)**

*This recipe is also low in fat. We used CSR Smart sugar for this recipe but if using another sugar replacement use ½ cup.*

Cooking & Prep time:

10 minutes + chilling time

1 cup (250 ml) evaporated skim milk

¼ cup sugar replacement

1½ cups (375 ml) skim milk

4 egg yolks

2 teaspoons vanilla essence

1. Combine ingredients in a large mixing bowl and mix well.
2. Refrigerate mixture until completely chilled.
3. Position the ice cream maker as directed on pages 5-6. Turn unit on; add mixture through the pouring hole.
4. When mixture has thickened and reaches the top of the paddle, the ice cream is completely prepared and the ice cream maker should be turned off. To avoid the motor overheating, the ice cream maker may turn itself off when the mixture has thickened and is ready.

*Nutritional information per 100g*

328kj; 2.8g total fat; 0.9g sat fat; 6.8g protein; 6.5g carbohydrates; 6.5g sugars

### GELATO

There are many different styles of gelato; we have chosen two styles, sugar syrup and custard based. Sugar syrup gelato has a light refreshing taste with a hint of creaminess to them while a custard based gelato has a creamier texture but is lighter than ice cream.

When making sugar syrup based gelato it is essential that the freezer canister is as cold as possible. In most cases the ice cream maker will not turn itself off as gelato has a softer consistency. To gauge if your gelato is ready, wait until the mixture comes close or to the top of the paddle or looks quite frozen. This time will vary depending on temperature of ingredients, freezer canister and ambient temperature.

### Sugar Syrup

**Makes approx. 1 cup**

Cooking & Prep time:

10 minutes + chilling time

1 cup (250ml) water

½ cup (110g) caster sugar

1. Place the water and sugar in a small saucepan.
2. Stir over a low heat until the sugar dissolves. Bring to the boil and cook for 2 minutes. Remove from heat. Cool to room temperature. Refrigerate for several hours or overnight.
3. Sugar syrup will keep for several weeks stored in an airtight container in the refrigerator.

## Recipes (continued)

### **Green Apple Gelato**      **Makes approx. 750ml**

Cooking & Prep time:

20 minutes + chilling time

- 1 quantity sugar syrup
  - 3 small green apples, juiced
  - 2 tablespoons freshly squeezed lemon juice
  - $\frac{2}{3}$  cup (160ml) thickened cream
1. Follow steps 1-2 for sugar syrup, including the apple and lemon juice into the mixture.
  2. Strain mixture through a fine sieve.  
Refrigerate for several hours or overnight.
  3. Whisk together the apple syrup and cream in a jug.
  4. Position the ice cream maker as directed on pages 5-6. Turn unit on; add mixture through the pouring hole.
  5. When mixture has thickened and reaches the top of the paddle, the ice cream is completely prepared and the ice cream maker should be turned off. To avoid the motor overheating, the ice cream maker may turn itself off when the mixture has thickened and is ready.

**Tip:** For a slightly greener colour use 1-2 drops of green food colouring.

### **Lemon Gelato**      **Makes approx. 750ml**

Cooking & Prep time:

20 minutes + chilling time

- 1 quantity sugar syrup
  - $\frac{1}{4}$  cup lemon zest
  - $\frac{2}{3}$  cup (160ml) freshly squeezed lemon juice
  - $\frac{2}{3}$  cup (160ml) thickened cream
1. Follow steps 1-2 for sugar syrup, including the lemon zest and juice into the mixture.
  2. Strain mixture through a fine sieve.  
Refrigerate for 4-6 hours or overnight.

3. Whisk together the lemon syrup and cream in a jug.
4. Position the ice cream maker as directed on pages 5-6. Turn unit on; add mixture through the pouring hole.
5. When mixture has thickened and reaches the top of the paddle, the ice cream is completely prepared and the ice cream maker should be turned off. To avoid the motor overheating, the ice cream maker may turn itself off when the mixture has thickened and is ready.

### **Ruby Red Grapefruit Gelato**      **Makes approx. 750ml**

Cooking & Prep time:

20 minutes + chilling time

- 1 quantity sugar syrup
  - 1 tablespoon grated ruby red grapefruit zest
  - $\frac{2}{3}$  cup (160ml) freshly squeezed ruby red grapefruit juice
  - $\frac{2}{3}$  cup (160ml) thickened cream
  - 1-2 drops red food colouring, optional
1. Follow steps 1-2 for sugar syrup, including the grapefruit zest and juice into the mixture.
  2. Strain mixture through a fine sieve.  
Refrigerate for 4-6 hours or overnight.
  3. Whisk together the ruby red grapefruit syrup, cream and red food colouring in a jug.
  4. Position the ice cream maker as directed on pages 5-6. Turn unit on; add mixture through the pouring hole.
  5. When mixture has thickened and reaches the top of the paddle, the ice cream is completely prepared and the ice cream maker should be turned off. To avoid the motor overheating, the ice cream maker may turn itself off when the mixture has thickened and is ready.

## Recipes (continued)

### Custard Based Gelato

#### **Gelato Custard Base**      **Makes approx. 950ml**

Cooking & Prep time:

35 minutes + chilling time

2 cup (500ml) milk

½ cup (125ml) light cream

5 egg yolks

½ cup (110g) caster sugar

1. Combine milk and cream in a saucepan. Bring the mixture to simmering point over low heat.
2. Whisk egg yolks and sugar together for 3-4 minutes, until light and creamy.
3. Gradually whisk in hot milk mixture into yolk mixture until well combined.
4. Return the mixture into a clean saucepan and cook, stirring constantly with a wooden spoon, over low heat until mixture thickens and coats the back of the spoon. Do not allow mixture to boil or it will curdle.

**Tip:** For further tips on custard making see page 8.

5. Transfer mixture to a bowl; allow to cool before placing in the fridge to chill for several hours.
6. Position the ice cream maker as directed on pages 5-6. Turn unit on; add mixture through the pouring hole.
7. When mixture has thickened and reaches the top of the paddle, the ice cream is completely prepared and the ice cream maker should be turned off. To avoid the motor overheating, the ice cream maker may turn itself off when the mixture has thickened and is ready.

### Gelato variations

#### **Chocolate Nougat Gelato**      **Makes approx. 1 litre**

Cooking & Prep time:

25 minutes + chilling time

1 quantity gelato custard base

80g Toblerone chocolate, chopped

50g chopped Toblerone chocolate, extra

1. Follow steps 1-7 for gelato custard base. Heating the 80g chocolate with the cream and milk.
2. Add chopped chocolate to the gelato mixture through the pouring hole when churning.

#### **Passionfruit Gelato**      **Makes approx. 1 litre**

*You will need approximately 4 passionfruit for this recipe*

Cooking & Prep time:

40 minutes + chilling time

1 quantity gelato custard base

⅓ cup passionfruit pulp

1. Follow steps 1-7 for gelato custard base.
2. Stir through passionfruit before churning.

#### **Pistachio Gelato**      **Makes approx. 1 litre**

Cooking & Prep time:

40 minutes + chilling time

1 quantity gelato custard base

⅓ cup (50g) roasted and chopped pistachios

1. Follow steps 1-7 for gelato custard base.
2. Add chopped pistachios to the gelato mixture through the pouring hole when churning.

## Recipes (continued)

### **SORBET**

A delicious dairy and fat free dessert which is a perfect way to finish off a meal or enjoy as a treat on a hot day! Sorbets have a sugar syrup base.

When making sorbets it is essential that the freezer canister is as cold as possible. In most cases the paddle will not turn itself off as sorbet has a softer consistency. To gauge if your sorbet is ready, wait until the mixture comes close to the top of the paddle or looks quite frozen. This time will vary depending on temperature of ingredients, freezer canister and ambient temperature.

#### **Sugar Syrup**

**Makes approx. 1 cup**

Cooking & Prep time:

10 minutes + chilling time

1 cup (250ml) water

½ cup (110g) caster sugar

1. Place the water and sugar in a small saucepan.
2. Stir over a low heat until the sugar dissolves. Bring to the boil and cook for 2 minutes. Remove from heat and allow to cool at room temperature before refrigerating for a 2-3 hours or until cold.

#### **Mixed Berry Sorbet**

**Makes approx. 750ml**

Cooking & Prep time:

20 minutes + chilling time

500g frozen mixed berries, thawed

1½ tablespoons lime juice

1 quantity sugar syrup

1. Place thawed berries and their juices in a food processor and puree until smooth. Push berries through a sieve to remove the seeds. Chill.

2. Combine the sugar syrup, berries and lime juice and stir to combine.
3. Position the ice cream maker as directed on pages 5-6. Turn unit on; add mixture through the pouring hole.
4. When mixture has thickened and reaches the top of the paddle, the ice cream is completely prepared and the ice cream maker should be turned off. To avoid the motor overheating, the ice cream maker may turn itself off when the mixture has thickened and is ready.

#### **Watermelon Sorbet**

**Makes approx. 1 litre**

*You will need 1.2kg watermelon for this recipe*

Cooking & Prep time:

10 minutes + chilling time

1 quantity sugar syrup

2 cups (500ml) freshly juiced watermelon

2 tablespoons lemon juice

1. Combine the sugar syrup, watermelon and lemon juice and stir to combine.
2. Position the ice cream maker as directed on pages 5-6. Turn unit on; add mixture through the pouring hole.
3. When mixture has thickened and reaches the top of the paddle, the ice cream is completely prepared and the ice cream maker should be turned off. To avoid the motor overheating, the ice cream maker may turn itself off when the mixture has thickened and is ready.

## Recipes (continued)

### **Fresh Pineapple and Mint Sorbet**

**Makes approx. 750ml**

*You will need approximately 1 pineapple for this recipe*

Cooking & Prep time:

10 minutes + chilling time

1 quantity sugar syrup

2½ cups freshly juiced pineapple juice

1 tablespoon finely shredded mint

1. Combine the sugar syrup, pineapple juice and shredded mint and stir to combine.
2. Position the ice cream maker as directed on pages 5-6. Turn unit on; add mixture through the pouring hole.
3. When mixture has thickened and reaches the top of the paddle, the ice cream is completely prepared and the ice cream maker should be turned off. To avoid the motor overheating, the ice cream maker may turn itself off when the mixture has thickened and is ready.

### **FROZEN YOGURT**

#### **Vanilla Frozen Yogurt**

**Makes approx. 1 litre**

Cooking & Prep time:

5 minutes + chilling time

550g vanilla yogurt

260ml milk

135g caster sugar

½ teaspoon vanilla extract

1. Whisk ingredients together in a large jug.
2. Refrigerate for 1 hour or until well chilled.
3. Position the ice cream maker as directed on pages 5-6. Turn unit on; add mixture through the pouring hole.
4. When mixture has thickened and reaches

the top of the paddle, the ice cream is completely prepared and the ice cream maker should be turned off. To avoid the motor overheating, the ice cream maker may turn itself off when the mixture has thickened and is ready.

#### **Lychee Frozen Yogurt**

**Makes approx. 1 litre**

Cooking & Prep time:

15 minutes + chilling time

450g can lychees, well drained

375g low fat vanilla yogurt

175ml low fat milk

90g caster sugar

1. Blend or process lychees until smooth.
2. Using an electric mixer, mix the lychees with the yogurt, milk and sugar until well combined.
3. Return mix to fridge until well chilled.
4. Position the ice cream maker as directed on pages 5-6. Turn unit on; add mixture through the pouring hole.
5. When mixture has thickened and reaches the top of the paddle, the ice cream is completely prepared and the ice cream maker should be turned off. To avoid the motor overheating, the ice cream maker may turn itself off when the mixture has thickened and is ready.

# 12 Month Replacement Guarantee

In the unlikely event that this appliance develops any malfunction within 12 months of purchase (3 months commercial use) due to faulty materials or manufacture, we will replace it for you free of charge.

Should you experience any difficulties with your appliance, please phone our customer service line for advice on 1300 881 861 in Australia, or 0800 786 232 in New Zealand. Alternatively, you can send a written claim to Sunbeam at the address listed below. On receipt of your claim, Sunbeam will seek to resolve your difficulties or, if the appliance is defective, advise you on how to obtain a replacement or refund.

Your Sunbeam 12 Month Replacement Guarantee naturally does not cover misuse or negligent handling and normal wear and tear.

Similarly your 12 Month Replacement Guarantee does not cover freight or any other costs incurred in making a claim. Please retain your receipt as proof of purchase.

The benefits given to you by this guarantee are in addition to your other rights and remedies under any laws which relate to the appliance.

Our goods come with guarantees that cannot be excluded under the Australian Consumer Law and under the New Zealand Consumer Guarantees Act.

In Australia you are entitled to a replacement or refund for a major failure and for compensation for any other reasonably foreseeable loss or damage. You are also entitled to have the goods repaired or replaced if the goods fail to be of acceptable quality and the failure does not amount to a major failure.

Should your appliance require repair or service after the guarantee period, contact your nearest Sunbeam service centre.

For a complete list of Sunbeam's authorised service centres visit our website or call:

## **Australia**

[www.sunbeam.com.au](http://www.sunbeam.com.au)

**1300 881 861**

Units 5 & 6, 13 Lord Street  
Botany NSW 2019 Australia

## **New Zealand**

[www.sunbeam.co.nz](http://www.sunbeam.co.nz)

**0800 786 232**

26 Vestey Drive, Mt Wellington  
Auckland, New Zealand

## Need help with your appliance?

Contact our customer service team or visit our website for information and tips on getting the most from your appliance.

### In Australia

Visit [www.sunbeam.com.au](http://www.sunbeam.com.au)

Or call 1300 881 861

### In New Zealand

Visit [www.sunbeam.co.nz](http://www.sunbeam.co.nz)

Or call 0800 786 232

 is a registered trademark.

'Snack Heroes' is a trademark of Sunbeam Corporation.

Made in China.

Due to minor changes in design or otherwise, the product may differ from the one shown in this leaflet.

© Copyright. Sunbeam Corporation Limited 2012.

ABN 45 000 006 771

Units 5 & 6, 13 Lord Street

Botany NSW 2019 Australia

Unit 3, Building D

26 Vestey Drive

Mt Wellington Auckland

New Zealand

Sunbeam Corporation is a division of GUD Holdings Ltd.



## Free Manuals Download Website

<http://myh66.com>

<http://usermanuals.us>

<http://www.somanuals.com>

<http://www.4manuals.cc>

<http://www.manual-lib.com>

<http://www.404manual.com>

<http://www.luxmanual.com>

<http://aubethermostatmanual.com>

Golf course search by state

<http://golfingnear.com>

Email search by domain

<http://emailbydomain.com>

Auto manuals search

<http://auto.somanuals.com>

TV manuals search

<http://tv.somanuals.com>