



Twin Thunder™

Problems flying?
Do not return your
Air Hogs® to the store.
Call the Air Hogs®
flight training center
at
1-800-622-8339

WARNING:
CHOKING HAZARD – Small parts.
Not for Children under 3 years.

! Do not touch the running propeller!
Do not play above someone's head!
Adult supervision is required!

DANGER!
DO NOT PUNCTURE THE STYROFOAM!
THE BATTERY WILL BE DAMAGED.

Key Features

- 3 Channel Multi Function
- Advanced Stability System
- 6-Way Control
- Remote Control Searchlight

CONTENTS LIST AND PARTS IDENTIFICATION

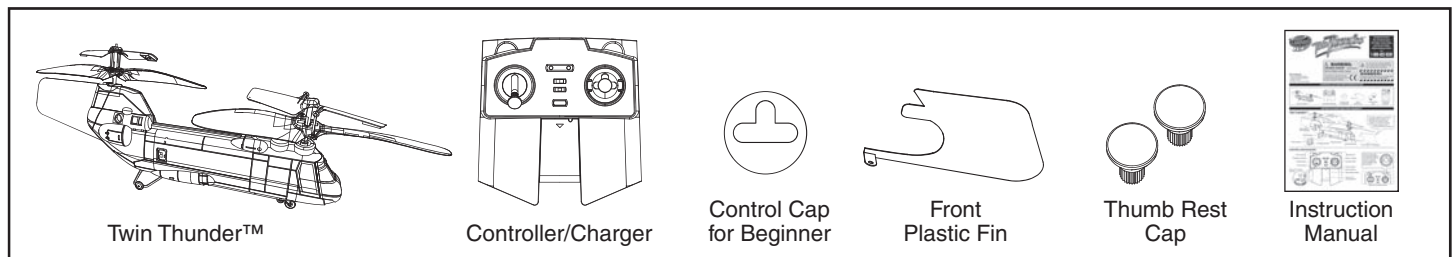

GETTING TO KNOW YOUR TWIN THUNDER™

TWIN THUNDER™

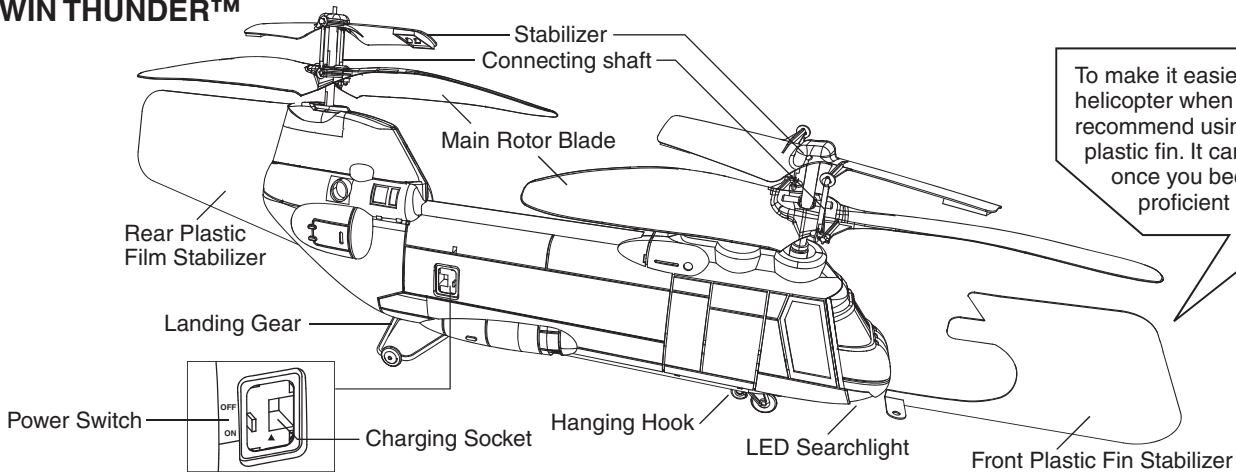

To make it easier to control this helicopter when training, we recommend using the front plastic fin. It can be removed once you become more proficient with the controls.

CONTROLLER/CHARGER

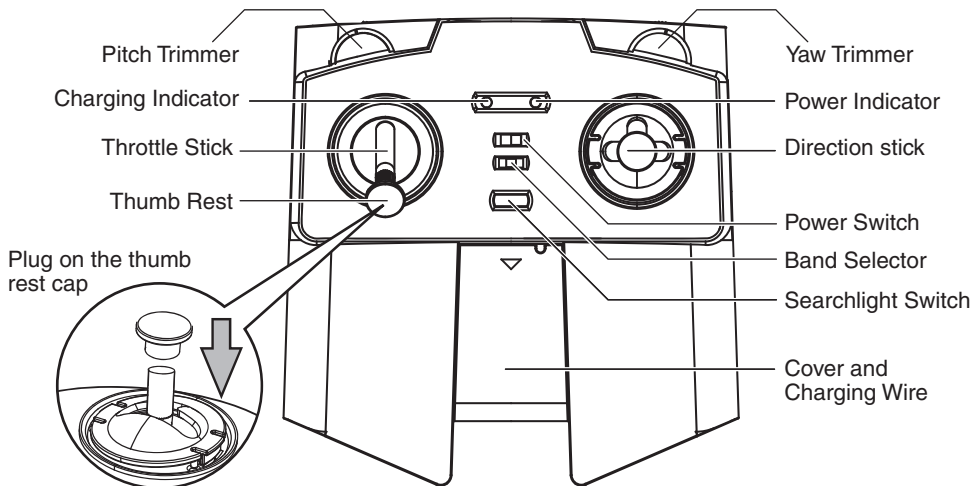

Spare control Cap – It is recommended to use this when training. It can be removed once you become more proficient with the controls.

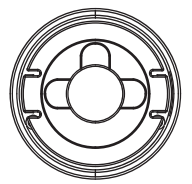

Minimum Throttle position

HOW TO INSTALL YOUR BATTERIES

BATTERY INSTALLATION – CONTROLLER/CHARGER

Make sure the power switch is in the "OFF" position. 1. Use a Phillips head (Cross-Head) screwdriver to loosen the screws on the battery cover counter-clockwise (pic.1). 2. Put 6 AA size batteries in the battery compartment as per the polarity shown inside (pic.2). 3. Tighten the screw clockwise (pic.3).

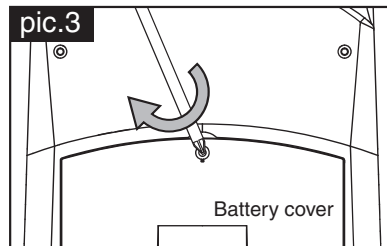
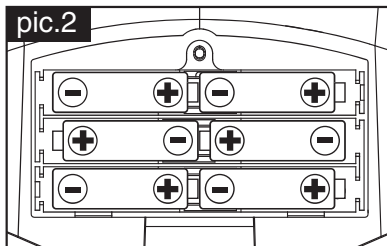
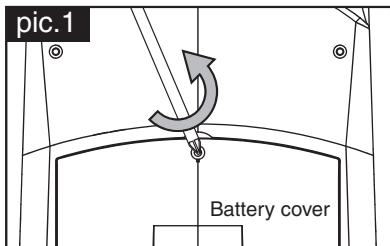

HOW TO CHARGE YOUR TWIN THUNDER™

1. Pull down the cover and take out the charging wire. (pic.4) 2. Turn off the power to the helicopter. Insert the charging plug into the socket on the bottom of the helicopter. (pic.5) 3. Turn on the power to the controller/charger. 4. The green LED will light up when charging (pic.6). Once completed, the green LED will turn off. Pull the plug out of the socket on the helicopter. 5. The helicopter will have about 5-6 minutes of flight time after 20-30 minutes of charging.

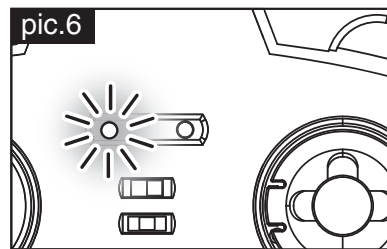
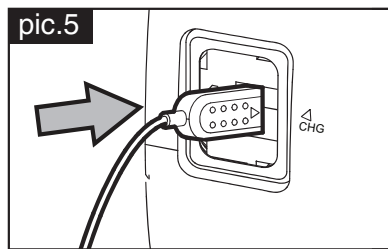
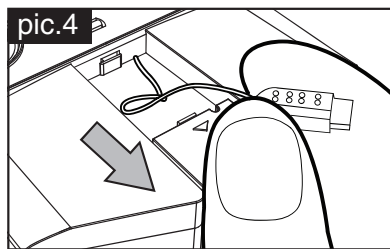

Note: To maximize battery life, wait for 10-15 minutes to let the battery cool down before recharging.

HOW TO FLY YOUR TWIN THUNDER™

- Set the band on your controller/charger to the same as on the bottom of the helicopter (A,B, or C). - Set the ON/OFF switch on the helicopter to "ON", the power indicator will flash, **BE SURE THE CONTROLLER/CHARGER IS "OFF"** when turning on the helicopter. - Place the helicopter on the ground with the tail pointing towards you and the nose facing away from you. - Set the left stick on the controller/charger to MINIMUM throttle, and then set the power to "ON".

1. TRIMMING YOUR HELICOPTER:

- Gently push the throttle up to raise your helicopter no higher than 1.5 ft (.5 m). - If the helicopter spirals clockwise (pic.7) or keeps turning clockwise (pic.8), turn the YAW trimmer counter-clockwise gently till the turning stops and helicopter flies straight (pic.9).

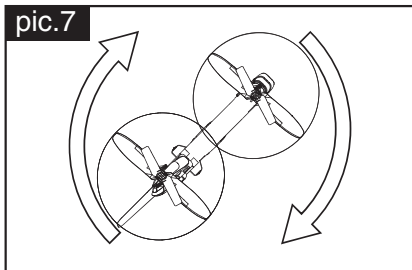

Spiral clockwise

or

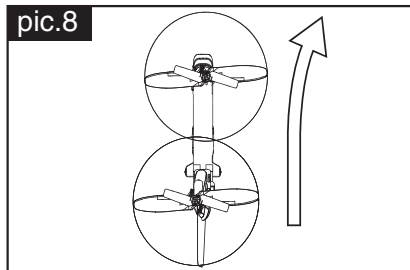

Keep turning clockwise

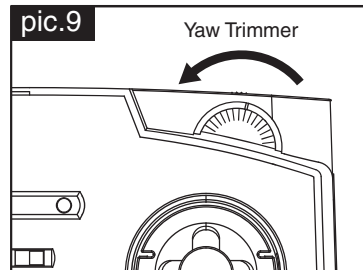

- If the helicopter spirals counter-clockwise (pic. 10) or keeps turning counter-clockwise (pic. 11), turn the YAW trimmer clockwise gently till the turning stops and helicopter flies straight (pic. 12).

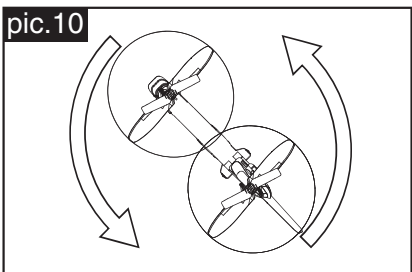

Spiral counter clockwise

or

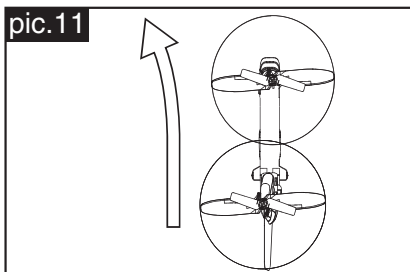

Keep turning counter clockwise

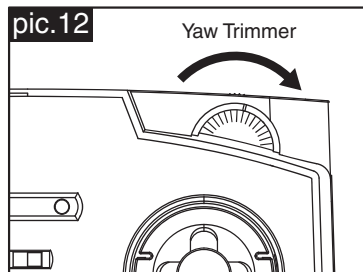

- If the helicopter flies forward, turn the PITCH trimmer counter-clockwise gently till the forward movement stops and helicopter starts hovering (pic. 13). - If the helicopter flies backward, turn the PITCH trimmer clockwise gently till the backward movement stops and helicopter starts hovering (pic. 14).

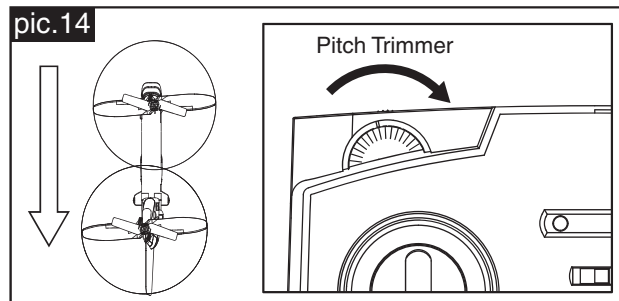
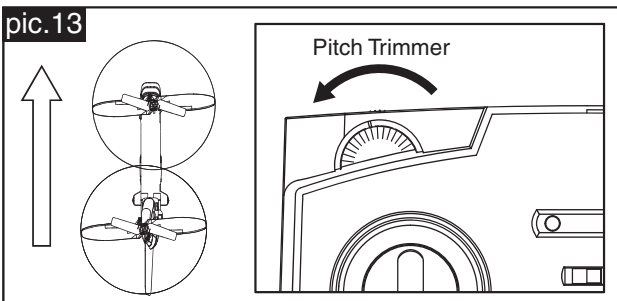

2. FLIGHT CONTROL:

Hover up and down:

When the helicopter flies steadily, you can slowly push the throttle stick up to make helicopter fly higher, or release the stick a bit to make helicopter fly lower. Only small amounts of stick position change are required for smooth flying. (Pic.15 & Pic.16)

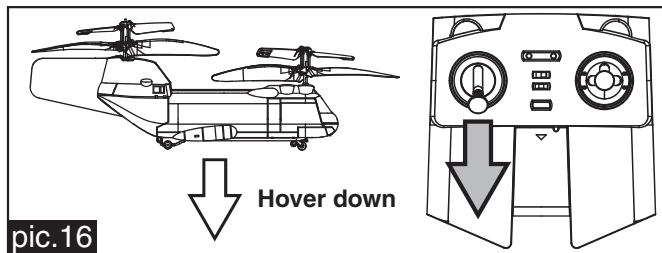
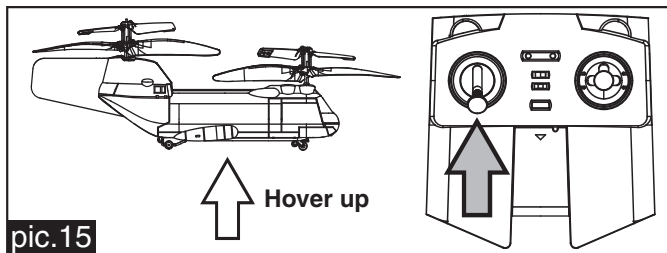

Turn counter clockwise and clockwise:

Gently push the rudder stick toward left to turn counter-clockwise (pic.17), or right to turn clockwise. (pic.18)

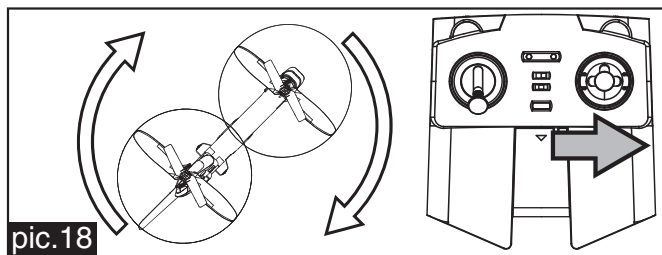
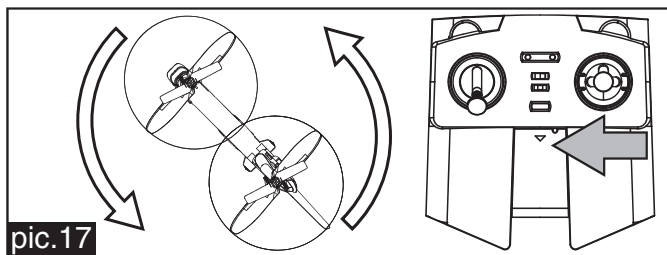

Fly forward and backward:

Hold the helicopter at a height. Push the direction stick toward up to fly forward (pic. 19), and push the stick toward down to fly backward (pic. 20).

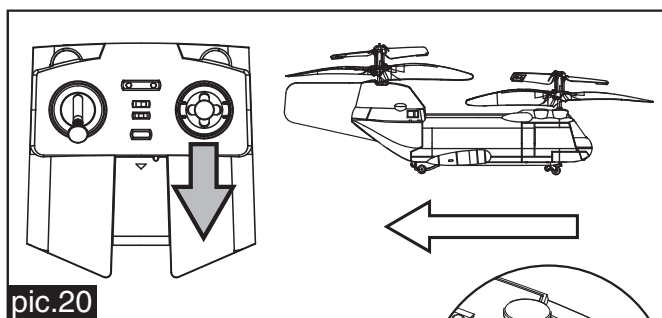
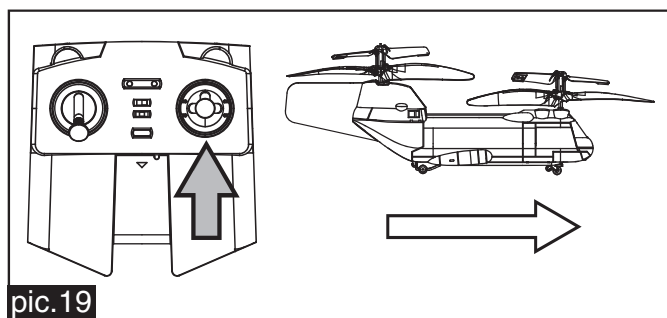

3. FLIGHT CONTROL TIPS

- Launch the helicopter on a smooth surface. Uneven surfaces will affect its ability to lift off.
- Slowly increase the throttle.
- DO NOT look at the controller/charger but focus on the helicopter.
- As soon as the helicopter leaves the ground, reduce the throttle slightly.
- Make slow gentle adjustments when reducing or increasing throttle.

4. CHOOSE AN IDEAL FLIGHT ENVIRONMENT

Choose the place which meets the following conditions:

1. Indoor environment with calm air-conditioning. Beware of the air circulation from the air-conditioner.
2. Space area: It is recommended to have space area over 10 ft (W) x 16.5 ft (L) x 8 ft (H).
3. Safety area: It is highly recommended that there is no electric fan, air-conditioner, reading lamp or other dangerous obstacles near while flying.

Tip! OPERATION

- If you crash your helicopter you may need to switch the ON/OFF button to "ON" again to restart.
- Don't operate the helicopter under direct bright light as it may affect the control system of your helicopter.
- Don't cover the IR Diode of the controller/charger as it will block the IR signal.

Tip! CONTROLLING

- Practice hovering your helicopter first, before using the directional controls. Make sure that you are able to maintain a steady hover at approximately 3 feet off of the ground before trying to steer the helicopter. Once you master this, it is recommended that you get comfortable turning the helicopter left and right, prior to attempting to control it forward/backward.

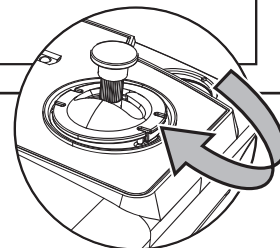

Note: Remove the direction aid to restore the backward control.

Tip! SAFETY

- Read the instruction manual before playing with your helicopter.
- This product is designed to be used only indoors.
- Fly the helicopter only in open areas and keep clear of obstacles.
- **Make sure you and other people keep 3-6 feet away from the helicopter while flying.**
- **Always keep your helicopter in view to prevent it from landing or crashing near your head, your body or on other people.**
- **Never disassemble or attempt to modify the product. It may cause damage to the product.**
- **Never put your hands or face near the rotating parts of the helicopter. Operate this product in a standing position which will allow you to quickly get out of the way if necessary.**
- **Always place the helicopter and the controller/charger in the "OFF" position when not flying.**
- **Never allow young children to use this product without adult supervision.**
- **Never use parts that are damaged or have had their shape altered in this product to ensure safe usage.**

WARNING:
NEVER INSERT ANY SHARP OBJECTS, PINS OR SCREWS INTO THE HELICOPTER AS THIS MAY PUNCTURE THE LITHIUM POLYMER BATTERY!

TROUBLESHOOTING

PROBLEM	CAUSE	SOLUTION
Main rotor won't turn.	ON/OFF switch is set to OFF.	Set switch to ON.
	Weak battery.	Re-charge the helicopter using the charging port OR check batteries in the controller.
Suddenly stops and drops while flying.	Weak power.	Re-charge helicopter or check battery power in controller.
	Helicopter may be out of range from controller.	
The Helicopter is not reacting to the controller.	A,B,C channel selection on controller is not correct.	Double check the letter on the bottom of the helicopter and adjust the channel selector on the controller.
	Helicopter may not be turned ON.	Turn helicopter ON.
Helicopter is losing control.	May be another infrared (IR) device using the same channel.	Avoid these if possible, or choose another place to operate the helicopter.
	Bright lights may be affecting the IR control.	Turn down lights or change flight environment.
	Helicopter may be too far away from the controller.	Stay closer to the helicopter with the controller.

For further questions and problems, please visit our website www.airhogs.com.

Safety Precautions:

Warning: Changes or modifications to this unit not expressly approved by the party responsible for compliance could void the user's authority to operate the equipment.

- Keep hands, hair and loose clothing away from the propeller when power switch is turned ON.
- Turn off controller/charger and helicopter when not in use.
- Remove battery from controller/charger when not in use.
- Parental guidance is recommended for the flight.
- Keep your helicopter in your sight so that you can supervise it all the time.

- New and alkaline batteries are recommended for use in controller/charger to obtain best and maximum performance.
- You are advised to replace with new batteries as soon as the function becomes impaired.
- Users should keep and retain this information for future reference.
- Users should keep strict accordance with the instruction manual while operation the product.
- Your controller/charger is tailor-made for the Li-Poly rechargeable battery used in Twin Thunder™. Do not use it to charge any battery other than that in the helicopter.

FCC Statements

This device complies with part 15 of the FCC rules. Operation is subject to the following two conditions:

- 1) This device may not cause harmful interference, and
- 2) This device must accept any interference received, including interference that may cause undesired operation.

NOTE: This equipment has been tested and found to comply with the limits for a Class B digital device, pursuant to Part 15 of the FCC Rules. These limits are designed to provide reasonable protection against harmful interference in a residential installation. This equipment generates, uses and can radiate radio frequency energy and, if not installed and used in accordance with the instructions, may cause harmful interference to radio communications.

However, there is no guarantee that interference will not occur in a particular installation. If this equipment does cause harmful interference to radio or television reception, which can be determined by turning the equipment off and on, the user is encouraged to try to correct the interference by one or more of the following measures:

- Reorient or relocate the receiving antenna.
- Increase the separation between the equipment and receiver.
- Connect the equipment into an outlet on a circuit different from that to which the receiver is connected.
- Consult the dealer or an experienced radio/TV technician for help.

Care and Maintenance:

- Always remove batteries from the toy when it is not being used for a long period of time. (controller/charger only)
- Wipe the toy gently with a clean damp cloth.
- Keep the toy away from direct heat.
- Do not submerge the toy into water that can damage the electronic assemblies.

Battery Cautions:

- Non-rechargeable batteries are not to be recharged
- Rechargeable batteries are to be removed from the toy before being charged (controller/charger only).
- Rechargeable batteries are only to be charged by an adult
- Different types of batteries or new and used batteries are not to be mixed (controller/charger only).
- Only batteries of the same or equivalent type as recommended are to be used.
- Batteries are to be inserted with correct polarity.
- Exhausted batteries are to be removed from the toy (controller/charger only).
- The supply terminals are not to be short-circuited.

Helicopter is equipped with a Li-Poly rechargeable battery, please also pay attention to the following cautions for safety use:

- Do not dispose the battery in fire or heat.
- Do not use or leave the battery near a heat source such as fire or heater.
- Do not strike or throw the battery against hard surface.
- Do not immerse the battery in water, and keep the battery in a cool dry environment.
- When recharging, only use the battery charger specifically for that purpose.
- Do not over-discharge the battery.
- Do not connect the battery to an electrical outlet.
- Do not directly solder the battery and pierce the battery with a nail or other sharp object.
- Do not transport or store the battery together with metal objects such as necklaces, hairpins etc.
- Do not disassemble or alter the battery.
- Charge the battery every 6 months.
- Turn off your equipment power switch after use.
- As for a used battery, please recycle after covering the battery terminals with insulation tape or inserting it to an individual poly-bag.

Note:

- Parental guidance is recommended when installing or replacing batteries.
- Under the environment with electrostatic discharge, the sample may malfunction and require user to reset the sample.

Special Note to Adults:

- Regularly examine for damage to the plug, enclosure and other parts. In the event of any damage, the toy must not be used with the controller/charger until the damage has been repaired.
- This toy is not intended for children under 3 years old.
- This toy must only be used with the recommended charger
- Do not try to charge other batteries with controller/charger.

Battery requirement for Twin Thunder™:



Power Supply : ---
Rating : DC 3.7 V, 1.8 W
Batteries : 1 x 3.7 V Li-Poly Rechargeable Battery Pack
Requires 1 x 3.7 V Li-Poly Rechargeable Battery Pack (included)

Battery requirement for Controller/charger:

Power Supply : ---
Rating : DC 6 V, 1.2 W
Batteries : 6 x 1.5 V "AA"/LR6/AM3
Requires 6 x 1.5 V "AA" size batteries (not included)



Spin Master Ltd., 450 Front Street West, Toronto, ON M5V 1B6 Canada
Spin Master Inc., PMB #10053, 300 International Drive, Suite 100, Williamsville, NY 14221, USA
Spin Master Toys Far East Limited. Rm #1113, 11/F, Chinachem Golden Plaza, 77 Mody Rd., Tsimshatsui E., Kowloon, HK
Spin Master Toys UK Ltd., Meadowbank, Furlong Road, Bourne End, Bucks, SL8 5AJ, United Kingdom
Spin Master France – 36 rue de Silly – 92100 Boulogne Billancourt – France

TM and © 2008 Spin Master Ltd. Air Hogs® is a registered trademark of Spin Master Ltd. All rights reserved. Conforms to product safety standards ASTM F963, regulatory requirements. Products and colors may vary. Please retain this information for future reference. Patent Pending. MADE IN CHINA.

North American Consumer Information
Phone: 1-800-622-8339
www.spinmaster.com

#20013763, #20013764 NEN REV 0



Free Manuals Download Website

<http://myh66.com>

<http://usermanuals.us>

<http://www.somanuals.com>

<http://www.4manuals.cc>

<http://www.manual-lib.com>

<http://www.404manual.com>

<http://www.luxmanual.com>

<http://aubethermostatmanual.com>

Golf course search by state

<http://golfingnear.com>

Email search by domain

<http://emailbydomain.com>

Auto manuals search

<http://auto.somanuals.com>

TV manuals search

<http://tv.somanuals.com>