



**SHARP**<sup>®</sup>  
SHARP CORPORATION

Printed on 100% post-consumer recycled paper.  
Gedruckt auf 100% wiederverwertungs Papier.  
Imprimé sur 100% de papier recyclé.  
Impreso en 100% de papel reciclado de postconsumo.

Printed in Japan  
Gedruckt in Japan  
Imprimé au Japon  
Impreso en Japón  
TINS-A842WJZZ  
03P07-JKK

LC-M3700/LC-M3710

OPERATION MANUAL  
MODE D'EMPLOI

BEDIENUNGSANLEITUNG  
MANUAL DE MANEJO

**SHARP**

**SHARP**<sup>®</sup>

**LC-M3700**  
**LC-M3710**

WIDE LCD MONITOR  
BREITBILD-LCD-MONITOR  
MONITEUR GRAND ÉCRAN À  
CRISTAUX LIQUIDES  
MONITOR LCD PANORÁMICO

OPERATION MANUAL  
BEDIENUNGSANLEITUNG  
MODE D'EMPLOI  
MANUAL DE MANEJO

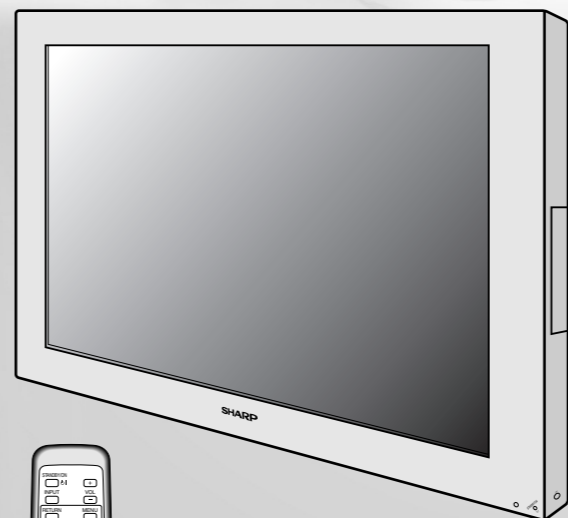

ENGLISH

DEUTSCH

FRANÇAIS

ESPAÑOL

# LC-M3700

# LC-M3710

WIDE LCD MONITOR

ENGLISH

## OPERATION MANUAL

### IMPORTANT:

To aid reporting in case of loss or theft, please record the product's model and serial numbers in the space provided. The numbers are located in the rear of the product.

Model No.:

Serial No.:

U.S.A. ONLY

## IMPORTANT INFORMATION

**WARNING:** TO REDUCE THE RISK OF FIRE OR ELECTRIC SHOCK, DO NOT EXPOSE THIS PRODUCT TO RAIN OR MOISTURE.



### CAUTION

RISK OF ELECTRIC  
SHOCK  
DO NOT OPEN



CAUTION: TO REDUCE THE RISK OF ELECTRIC SHOCK, DO NOT REMOVE COVER. NO USER-SERVICEABLE PARTS INSIDE. REFER SERVICING TO QUALIFIED SERVICE PERSONNEL.



The lightning flash with arrowhead symbol, within an equilateral triangle, is intended to alert the user to the presence of uninsulated "dangerous voltage" within the product's enclosure that may be of sufficient magnitude to constitute a risk of electric shock to persons.



The exclamation point within a triangle is intended to alert the user to the presence of important operating and maintenance (servicing) instructions in the literature accompanying the product.

## IMPORTANT INFORMATION (Continued)

**WARNING:** FCC Regulations state that any unauthorized changes or modifications to this equipment not expressly approved by the manufacturer could void the user's authority to operate this equipment.

U.S.A. ONLY

**CAUTION:** Use the supplied AC cord as it is.  
Do not remove the core part from the AC cord, and do not change the way of winding cables around the core part.

### INFORMATION:

This equipment has been tested and found to comply with the limits for a Class A digital device, pursuant to Part 15 of the FCC Rules. These limits are designed to provide reasonable protection against harmful interference in a residential installation. This equipment generates, uses, and can radiate radio frequency energy and, if not installed and used in accordance with the instructions, may cause harmful interference to radio communications. However, there is no guarantee that interference will not occur in a particular installation. If this equipment does cause harmful interference to radio or television reception, which can be determined by turning the equipment off and on, the user is encouraged to try to correct the interference by one or more of the following measures:

- Relocate or adjust the receiving antenna.
- Increase the separation between the equipment and receiver.
- Connect the equipment into an outlet on a circuit different from that to which the receiver is connected.
- Consult the dealer or an experienced radio/TV technician for help.

U.S.A. ONLY

### CAUTION

**Danger of explosion if battery is incorrectly replaced.**

**Replace only with the same or equivalent type  
recommended by the manufacturer.  
Dispose of used batteries according  
to the manufacturer's instructions.**

# DEAR SHARP CUSTOMER

Thank you for your purchase of a SHARP LCD product. To ensure safety and many years of trouble-free operation of your product, please read the Safety Precautions carefully before using this product.

## SAFETY PRECAUTIONS

Electricity is used to perform many useful functions, but it can also cause personal injuries and property damage if improperly handled. This product has been engineered and manufactured with the highest priority on safety. However, improper use can result in electric shock and/or fire. In order to prevent potential danger, please observe the following instructions when installing, operating and cleaning the product. To ensure your safety and prolong the service life of your LCD product, please read the following precautions carefully before using the product.

1. Read instructions—All operating instructions must be read and understood before the product is operated.
2. Keep this manual in a safe place—These safety and operating instructions must be kept in a safe place for future reference.
3. Observe warnings—All warnings on the product and in the instructions must be observed closely.
4. Follow instructions—All operating instructions must be followed.
5. Cleaning—Unplug the power cord from the AC outlet before cleaning the product. Use a damp cloth to clean the product. Do not use liquid cleaners or aerosol cleaners.
6. Attachments—Do not use attachments not recommended by the manufacturer. Use of inadequate attachments can result in accidents.
7. Water and moisture—Do not use the product near water, such as bathtub, washbasin, kitchen sink and laundry tub, swimming pool and in a wet basement.
8. Stand—Do not place the product on an unstable cart, stand, tripod or table. Placing the product on an unstable base can cause the product to fall, resulting in serious personal injuries as well as damage to the product. Use only a cart, stand, tripod, bracket or table recommended by the manufacturer or sold with the product. When mounting the product on a wall, be sure to follow the manufacturer's instructions. Use only the mounting hardware recommended by the manufacturer.
9. When relocating the product placed on a cart, it must be moved with utmost care. Sudden stops, excessive force and uneven floor surface can cause the product to fall from the cart.
10. Ventilation—The vents and other openings in the cabinet are designed for ventilation. Do not cover or block these vents and openings since insufficient ventilation can cause overheating and/or shorten the life of the product. Do not place the product on a bed, sofa, rug or other similar surface, since they can block ventilation openings. Do not place the product in an enclosed place such as a bookcase or rack, unless proper ventilation is provided or the manufacturer's instructions are followed.
11. Power cord protection—The power cords must be routed properly to prevent people from stepping on them or objects from resting on them.
12. The LCD panel used in this product is made of glass. Therefore, it can break when the product is dropped or applied with impact. Be careful not to be injured by broken glass pieces in case the LCD panel breaks.
13. Overloading—Do not overload AC outlets or extension cords. Overloading can cause fire or electric shock.
14. Entering of objects and liquids—Never insert an object into the product through vents or openings. High voltage flows in the product, and inserting an object can cause electric shock and/or short internal parts. For the same reason, do not spill water or liquid on the product.
15. Servicing—Do not attempt to service the product yourself. Removing covers can expose you to high voltage and other dangerous conditions. Request a qualified service person to perform servicing.



## SAFETY PRECAUTIONS (Continued)

---

16. Repair—If any of the following conditions occurs, unplug the power cord from the AC outlet, and request a qualified service person to perform repairs.
  - a. When the power cord or plug is damaged.
  - b. When a liquid was spilled on the product or when objects have fallen into the product.
  - c. When the product has been exposed to rain or water.
  - d. When the product does not operate properly as described in the operating instructions.

Do not touch the controls other than those described in the operating instructions. Improper adjustment of controls not described in the instructions can cause damage, which often requires extensive adjustment work by a qualified technician.
  - e. When the product has been dropped or damaged.
  - f. When the product displays an abnormal condition. Any noticeable abnormality in the product indicates that the product needs servicing.
17. Replacement parts—In case the product needs replacement parts, make sure that the service person uses replacement parts specified by the manufacturer, or those with the same characteristics and performance as the original parts. Use of unauthorized parts can result in fire, electric shock and/or other danger.
18. Safety checks—Upon completion of service or repair work, request the service technician to perform safety checks to ensure that the product is in proper operating condition.
19. Wall or ceiling mounting—When mounting the product on a wall or ceiling, be sure to install the product according to the method recommended by the manufacturer.
20. Heat sources—Keep the product away from heat sources such as radiators, heaters, stoves and other heat-generating products (including amplifiers).
21. Power source—This product must operate on a power source specified on the specification label. If you are not sure of the type of power supply used in your home, consult your dealer or local power company. For units designed to operate on batteries or another power source, refer to the operating instructions.

The LCD panel is a very high technology product with 3,147,264 thin film transistors, giving you fine picture details.

Occasionally, a few non-active pixels may appear on the screen as a fixed point of blue, green or red. Please note that this does not affect the performance of your product.

### **WARNING:**

To reduce the risk of fire or electric shock, do not expose this product to rain or moisture.

### **WARNING:**

This is a class A product. In a domestic environment this product may cause radio interference in which case the user may be required to take adequate measures.

	Page
<b>Dear SHARP Customer .....</b>	<b>3</b>
<b>Safety Precautions .....</b>	<b>3</b>
<b>Introduction .....</b>	<b>5</b>
Features .....	6
Part Names – Display .....	8
Removing the terminal cover .....	9
Part Names – Remote Control Unit .....	10
Removing the battery cover .....	11
Supplied Accessories .....	12
<b>Connection and Installation .....</b>	<b>13</b>
Connecting Peripheral Equipment .....	13
Connecting external speakers .....	18
Connecting the AC cord .....	19
Connecting multiple monitors .....	20
Mounting options .....	23
Bundling cables .....	29
<b>Basic Operation .....</b>	<b>30</b>
Turning on Power .....	30
Main POWER switch .....	30
STANDBY/ON .....	30
Remote Control Unit .....	31
Menu Items .....	32
Menu option selection .....	32
Menu screen explanation .....	33
PC (analog) input mode menu items .....	34
AV input mode menu items .....	35
Language setting .....	36
<b>PC Operation .....</b>	<b>37</b>
PC connection .....	37
Communication conditions .....	37
Communication procedure .....	38
RS-232C command table .....	46
<b>Settings and Adjustments .....</b>	<b>51</b>
Picture .....	51
Audio .....	53
Power control .....	53
Setup .....	54
Option .....	57
Detailed explanation .....	58
<b>Troubleshooting and Specifications .....</b>	<b>65</b>
Troubleshooting .....	65
Specifications .....	67
Optional Accessories .....	67
<b>Appendix .....</b>	<b>68</b>
Appendix 1: PC Compatibility Chart .....	68
Appendix 2: Dimensional Drawings .....	69
Appendix 3: Menu Option Reference Chart .....	70

# Features

Numbers within  refer to the main page(s) where the topic is explained.

## ● HIGH-DEFINITION (HD) PANEL

- A large, flat LCD display panel with 3.15 million pixels lets you enjoy a detailed, high-definition picture from a digital TV or a PC.

## ● ASV\* LOW-REFLECTION BLACK TFT LCD PANEL

- SHARP's unique ASV\* low-reflection BLACK TFT LCD panel provides higher luminance, higher contrast, and a wider viewing angle. This reduces reflection in the monitor when it is placed near a window, and ensures brighter, more vivid image reproduction. With a wide viewing angle of 170 degrees, both horizontally and vertically, the image is beautiful, even when viewed off axis.

\* ASV ... Advanced Super View

## ● CABINET DESIGN ENABLES VERTICAL AND HORIZONTAL INSTALLATION

- When mounted vertically, this monitor requires images coded for a vertical screen. It does not have image rotation capability.

## ● EQUIPPED WITH A VARIETY OF TERMINALS

- **INPUT1** Terminals are provided for two types of video input signal.  **Input Select**

Video Input (BNC-terminal) NTSC (3.58/4.43)/PAL/SECAM (\*1)

S-video Input (S-terminal) NTSC (3.58/4.43)/PAL/SECAM (\*1)

- **INPUT2** This terminal can be set for input or output.  **INPUT2 Select**

Video Input (RCA-terminal) NTSC (3.58/4.43)/PAL/SECAM (\*1)

- **INPUT3** This terminal enables selection of the video signal type.  **Input Select**

COMPONENT/RGB Input (BNC-terminal)

COMPONENT 480i/480p/576i/576p/1080i/720p (\*2)

RGB Conforms to PC analog input.  **Appendix 1** (\*2, \*3)

- **PC**

Analog Input (D-Sub terminal) VGA/SVGA/XGA/SXGA and others  **Appendix 1** (\*2, \*3)

Digital Input (DVI terminal) VGA/SVGA/XGA/SXGA and others  **Appendix 1**

\*1: There is a setting for auto-detection of the color system. (This is set to "Auto" at factory shipment.)

\*2: Frequency is auto-detected.

\*3: The INPUT3 (RGB) and PC (analog) inputs are compatible with Sync On Green input. PC (analog) input is compatible with Csync input.

## ● COMPATIBLE WITH VARIOUS COLOR SYSTEMS



- Compatible with NTSC (3.58/4.43), PAL (50/60) and SECAM.

Numbers within  refer to the main page(s) where the topic is explained.

**● ENLARGEMENT FUNCTION**  

- Allows output of enlarged images for 4- or 9-screen (“2x2” or “3x3”) setups, without using a special-purpose external device.

**● CHAIN CONNECTION OF MULTIPLE MONITORS**

- Enables chain connection of monitors using video signal output (composite-video/D-Sub) terminals. 
- Enables individual control via PC of multiple sets connected in a daisy chain using RS-232C cables.  

**● EXTERNAL CONTROL AND STATUS MONITORING FROM A PC**

- The monitor can be controlled in various ways from a PC. 
- Multiple monitors can be individually controlled by connecting them in a daisy chain. 

**● EXTERNAL SPEAKERS CAN BE CONNECTED** 

- Compatible speakers: L/R, 8 ohm, 10W or larger

**● EQUIPPED WITH BUILT-IN MONITOR SPEAKER (MONO)**



- When activated from the menu screen, you can check the audio input status using the built-in monitor speaker (mono).

**● CONTROL LOCK FUNCTIONS**  

- The monitor is equipped with various operation lock functions to prevent unintended operation or mischief. (The PIN can be set by the user.)

**Fluorescent Tubes**

■ The fluorescent tubes in this product have a limited lifetime.

- If the screen gets dark, flashes, or does not turn on, change the fluorescent tubes with new exclusive ones.

Expected lifetime: ..... 60,000 hours for LC-M3700 (horizontal mount)\*  
 40,000 hours for LC-M3710 (vertical mount)\*  
 \*When “Brightness” is set to a center value.

- For more information, please contact your product dealer.

■ Because of the property of fluorescent tubes, the screen may flash during the initial period of use. If this happens, please turn off the main power switch on the back of the monitor and turn on again to confirm operation.



# Part Names – Display

Numbers within  refer to the main page(s) where the topic is explained.

## Front view

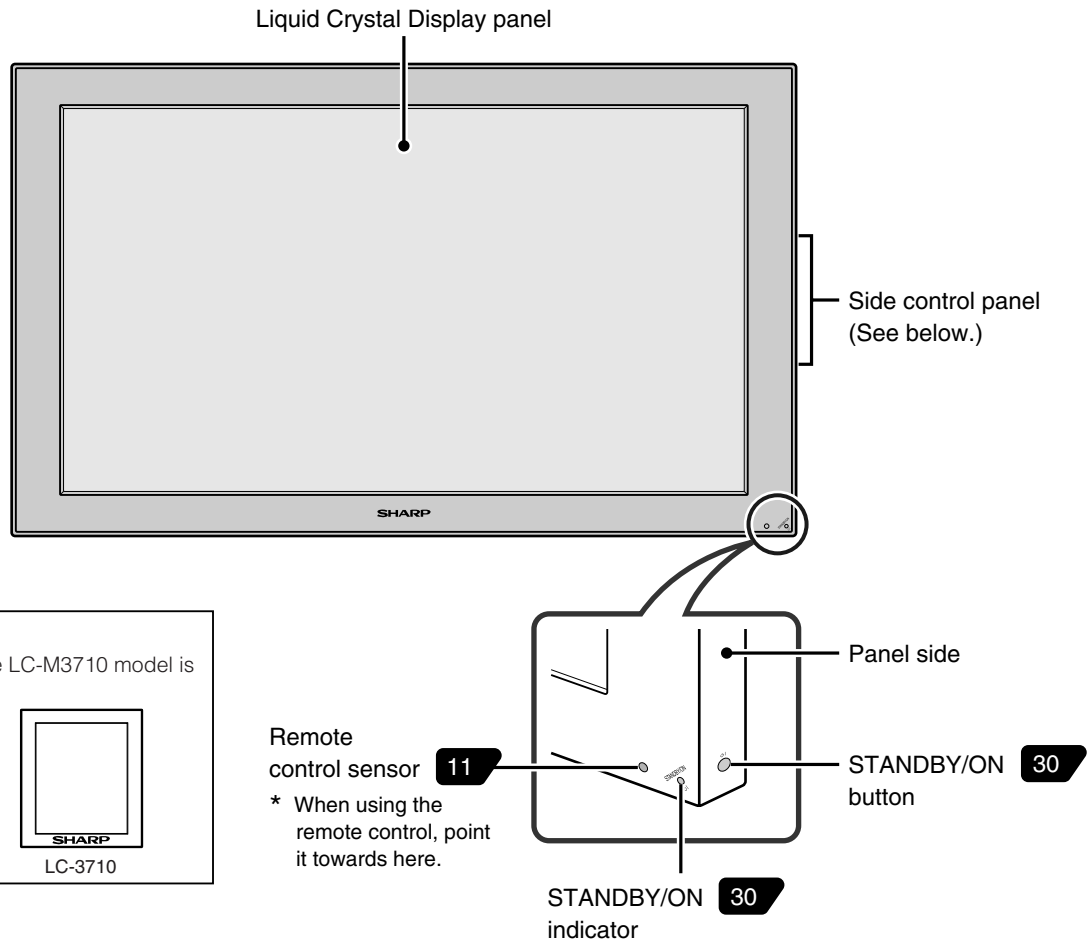

**About LC-M3710:**

- The SHARP logo for the LC-M3710 model is on the vertical base.

LC-3700      LC-3710

## Side control panel

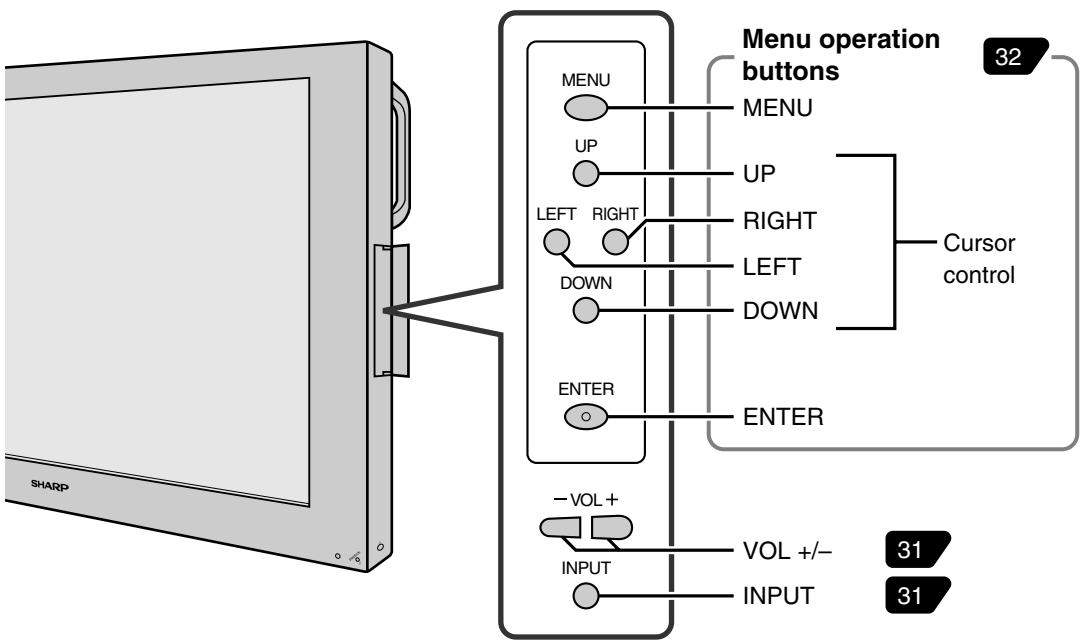

Rear view

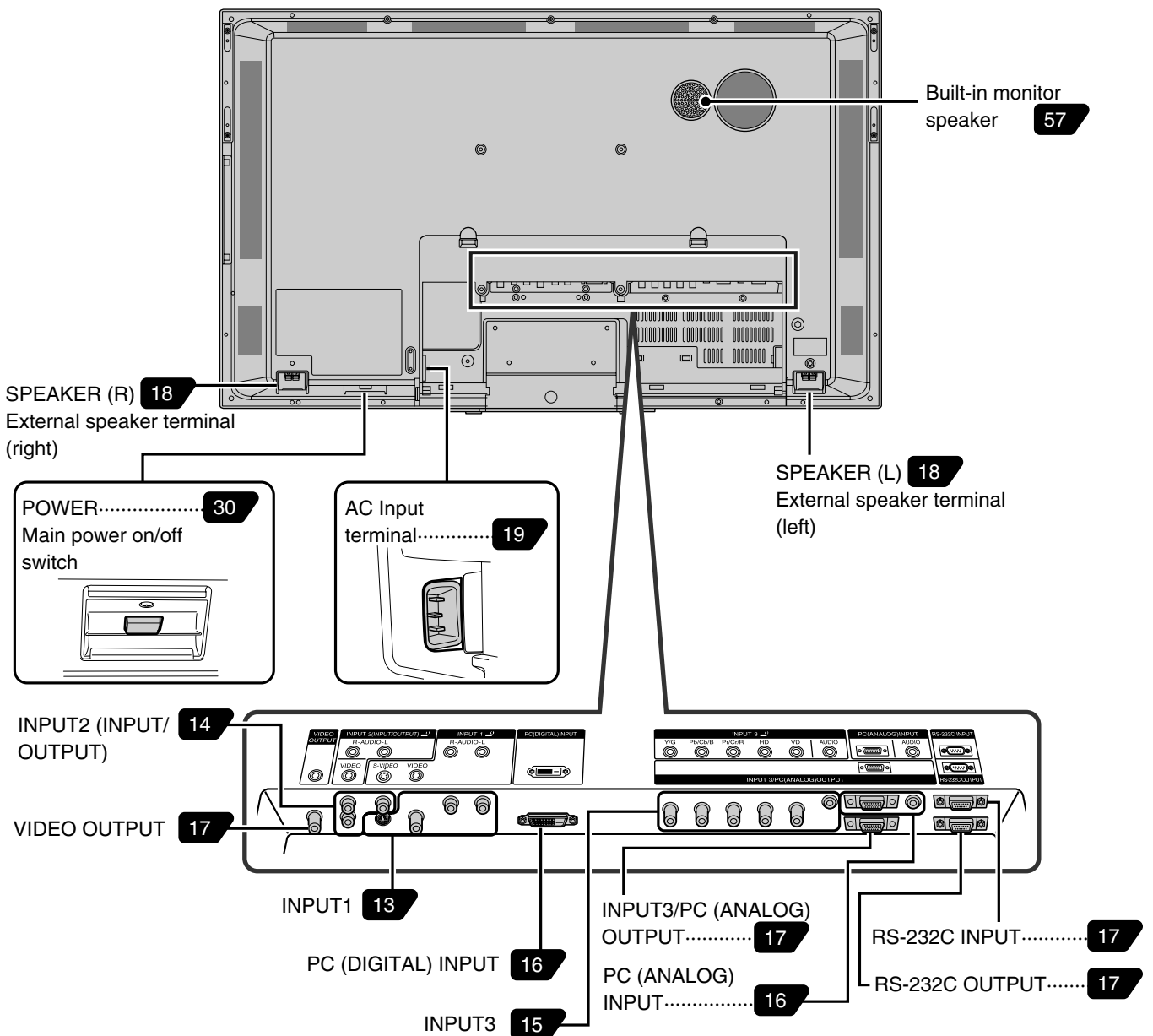

Removing the terminal cover

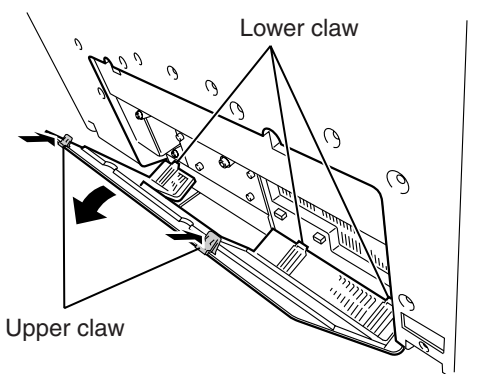

Removing the terminal cover

1. Hold down the two claws at the top of the terminal cover, and pull the cover toward you so it opens a little.
2. Slowly lift the cover so the three claws at the bottom come loose from the claw holes in the console.

# Part Names – Remote Control Unit

Numbers within  refer to the main page(s) where the topic is explained.

## Remote control unit

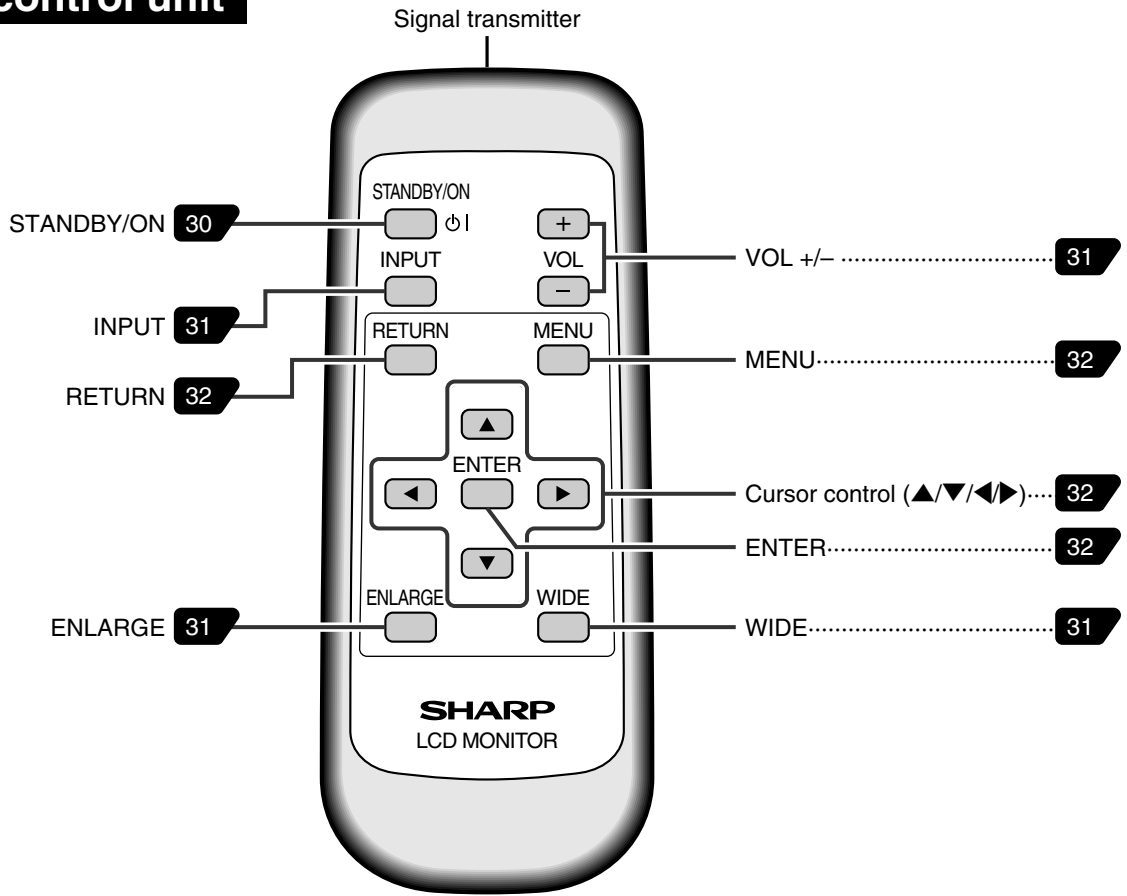

## Removing the battery cover

Gently hold down and press in the arrow direction.

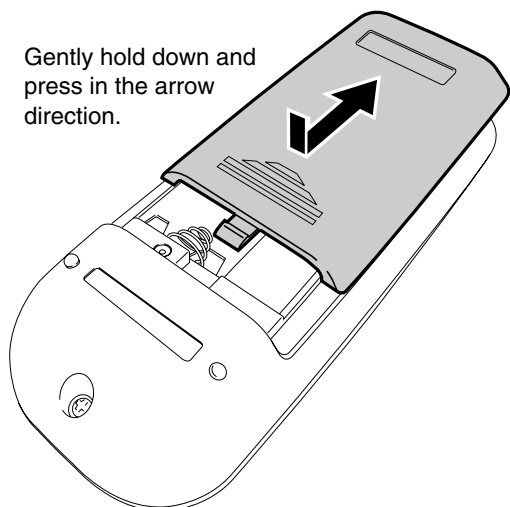

### Cautions regarding remote control unit

- Do not expose the remote control unit to shock. In addition, do not expose the remote control unit to liquids, and do not place it in an area with high humidity.
- The remote control unit may not work properly if the remote control sensor is under direct sunlight or strong lighting. In such cases, change the angle of the lighting or the monitor, or operate the remote control unit closer to the remote control sensor.

### Cautions regarding batteries

Improper use of batteries can result in chemical leakage or explosion. Be sure to follow the instructions below.



Caution

- Do not mix old and new batteries, or batteries of different types.
- Do not charge or disassemble batteries.
- Place batteries with their terminals corresponding to the  $\oplus$  and  $\ominus$  as indicated in the compartment.
- Do not short-circuit the batteries.



NOTE:

- The batteries supplied with this product may have a shorter life expectancy due to storage conditions. Replace with new batteries at the earliest opportunity.
- If you will not use the remote control for a long time, remove its batteries.
- If the remote control does not work, even with new batteries, take the batteries out, check whether they are facing the right way, then replace them.

## Remote control operation range

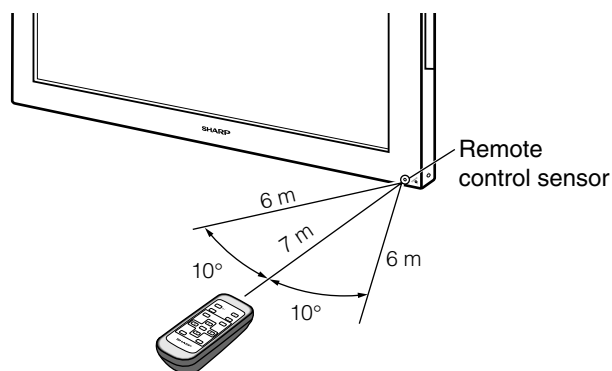

### If the remote control unit does not work well:

- Objects between the remote control unit and the remote control sensor may prevent proper operation.
- Replace the batteries when they run low as this may shorten the remote control operation range.

# Supplied Accessories

**Make sure the following accessories are provided with the product.**

Remote control unit (× 1)

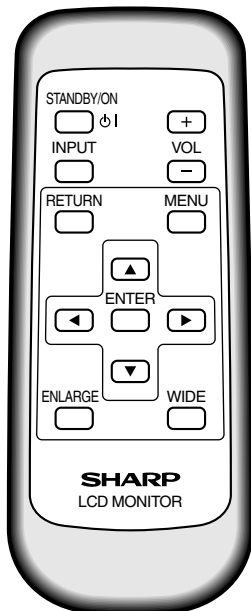

(RRMCGA186WJSA)

Pages 11, 30 - 32

“AA” size battery (× 2)

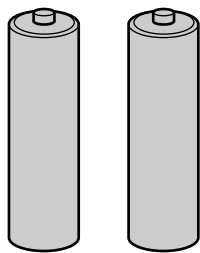

(UBATU0013TAZZ)

Page 11

AC cord, 9 ft.10-1/8”(3 m) (× 1)

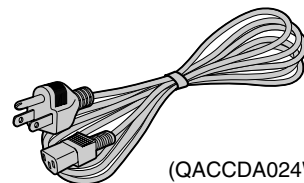

(QACCCA024WJPZ)

Page 19

Cable clamp (× 1)

Screw (× 1)

(XTBS940P-16000)



(LHLDW1118CEZZ)

Page 19

Cable binder (× 3)

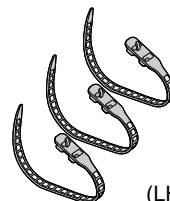

(LHLDWA017WJKA)

Page 29

Terminal cover mounting screw (× 2)

Flat washer (× 2)

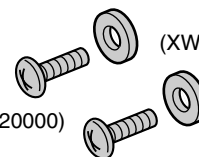

(XWHS960-16180)

(XBBS960P20000)

Page 29

- Operation manual × 1

## Caution:

- This monitor is equipped with a temporary stand when shipped from the factory. Please note this stand is for temporary use only until the monitor is properly mounted. Be sure to use a special-purpose AN-37ST1 table stand or AN-37AG1 wall-mount bracket (both optional). **23 Mounting Options.**

## INPUT1

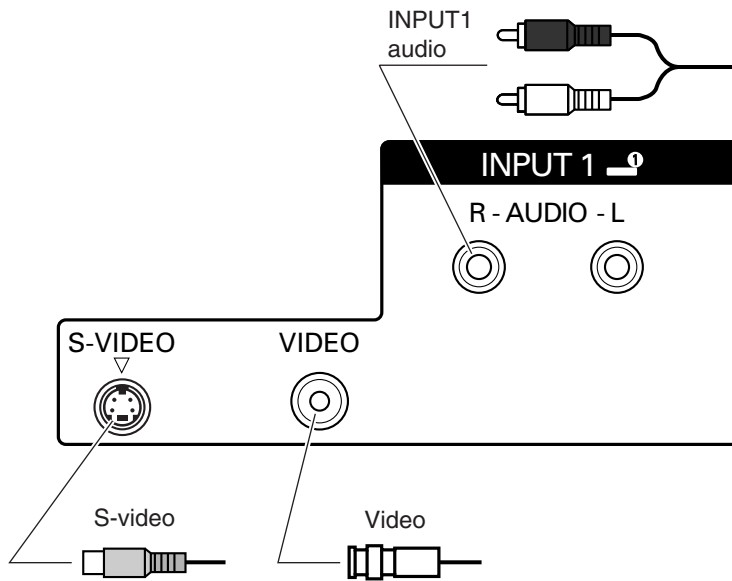

■ INPUT1: Terminals are provided for two types of video input signal. **54** Input Select

	Terminal type	Compatible signals
Video	BNC	NTSC (3.58/4.43), PAL, SECAM (*1)
S-video	S terminal	NTSC (3.58/4.43), PAL, SECAM (*1)

No matter which video signal is selected, the system uses the signal input to the audio terminals for audio.

### Related topic:

**54** Input Select

\*1 "Auto" (automatic color system detection) is factory preset value. **57** Color System

## INPUT2

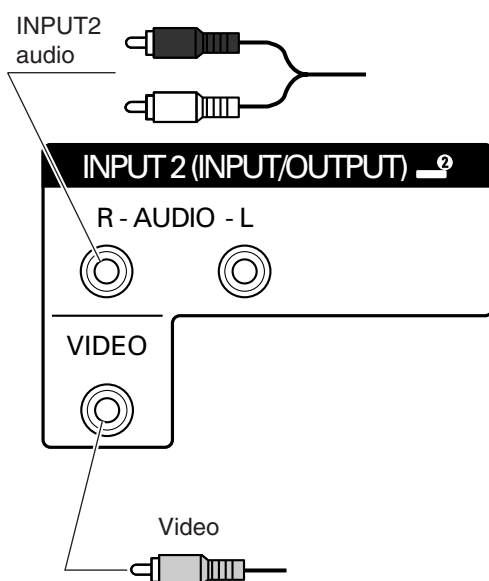

■ INPUT2: Input or output can be selected for INPUT2. (\*1) **56** INPUT2 Select  
 This setting cannot be switched when INPUT2 is currently being displayed.

	Terminal type	Compatible signals
Video	RCA	NTSC (3.58/4.43), PAL, SECAM (*2)

When this is set to “Output”, video signals input from the INPUT1 video input terminal are output. (\*3)  
 An audio signal is output with this setting (i.e. the audio signal corresponding to the video currently being displayed). (\*4)

### Related topic:

#### **56** INPUT2 Select

- \*1 “Input” is factory preset value.
- \*2 “Auto” (automatic color system detection) is factory preset value. **57** Color System
- \*3 Outputs video from INPUT1, regardless of the currently displayed signal.
- \*4 If the “INPUT2 Select” is set to “Output”, audio output is as follows.

#### Example 1

Input Selection **31** : INPUT1  
 “Input Select” **54** : AV



INPUT2 video output: Video from INPUT1  
 INPUT2 audio output: Audio from INPUT1

#### Example 2

Input Selection **31** : INPUT3  
 “Input Select” **54** : RGB



INPUT2 video output: Video from INPUT1  
 INPUT2 audio output: Audio from INPUT3

## INPUT3

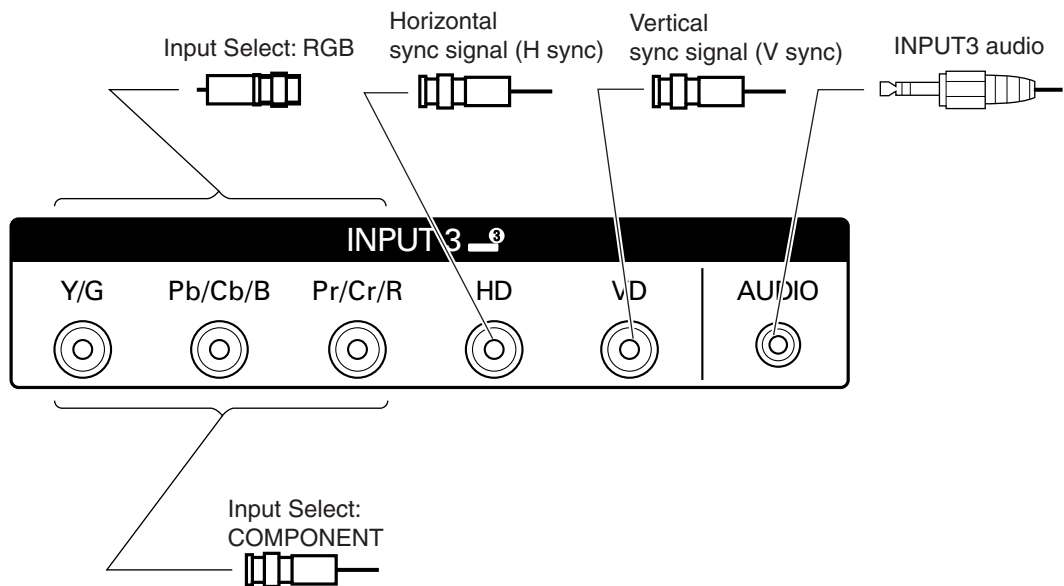

Connection and Installation

■ INPUT3: Either COMPONENT or RGB can be selected for the input video signal. **54** **Input Select**

COMPONENT	The signal is input with the Y/Pb/Pr (Y/Cb/Cr) terminals. The HD and VD terminals are not used. Video adjustment options on the menu are the AV type. Compatible input range: 480i/576i, 480p/576p, 1080i (50Hz (*4) /60Hz), 720p (60Hz). (*1)
RGB	The monitor operates using Video (RGB) and Sync (HD/VD) signals, just like a PC (analog). Supported sync signals are ordinary separate sync (HD/VD) and Sync On Green. (*2) (*3) Video adjustment options on the menu are the PC type. Compatible input range: Conforms to PC (analog). <b>68</b> <b>Appendix 1</b>

### Related topic:

#### **54** **Input Select**

- \*1 Auto-detects video signal frequency.
- \*2 Automatic sync signal type detection
- \*3 Sync signal presence is detected in the order: Separate Sync → Sync On Green. If for some reason Separate Sync is not input, the system will operate assuming that the signal is a Sync On Green signal (i.e. that the sync signal is contained in the G signal of RGB), and this may result in an unstable image, depending on the video signal.
- \*4 1080i (50Hz) corresponds to a SMPTE274M signal. (Horizontal frequency is 28.125kHz)



## Connecting Peripheral Equipment (Continued)

### PC

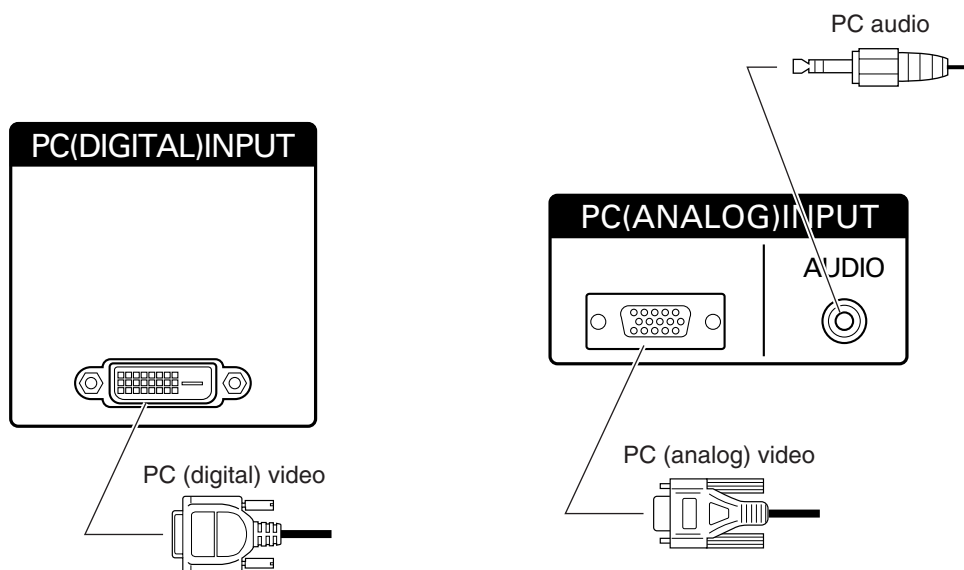

■ PC: Terminals for two kinds of PC video input signal are available. **54** **Input Select**

	Terminal type	Compatible signals
Analog	D-Sub15-pin	VGA, SVGA, XGA, SXGA and others <b>68</b> <b>Appendix 1</b> In addition to ordinary Separate Sync (HD/VD) signals, the system is also compatible with Composite Sync (Csync) and Sync On Green. (*1) (*2)
Digital	DVI-D	VGA, SVGA, XGA, SXGA and others <b>68</b> <b>Appendix 1</b>

No matter which video signal is selected, the system uses the signal input to the audio terminals for audio.

#### Related topic:

- \*1 Auto-detects Sync signal type.
- \*2 Sync signal presence is detected in the order: Separate Sync → Composite Sync → Sync On Green. If for some reason neither Separate Sync nor Composite Sync is input, the system will operate assuming that the signal is a Sync On Green signal (i.e. that the sync signal is contained in the G signal of RGB), and this may result in an unstable image, depending on the video signal.

### VIDEO OUTPUT

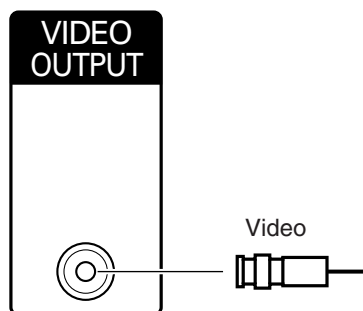

- When INPUT2 is displayed, video from INPUT2 is output. Otherwise video from INPUT1 is output.

### INPUT3/PC (ANALOG) OUTPUT

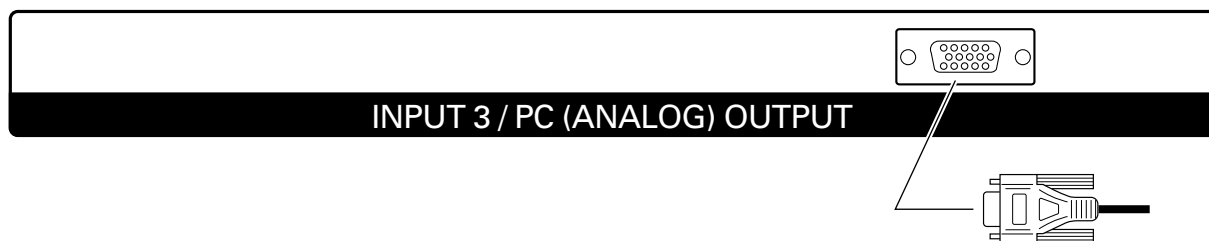

- When INPUT3 is displayed, video from INPUT3 is output. Otherwise PC (analog) video is output.

### RS-232C INPUT/RS-232C OUTPUT

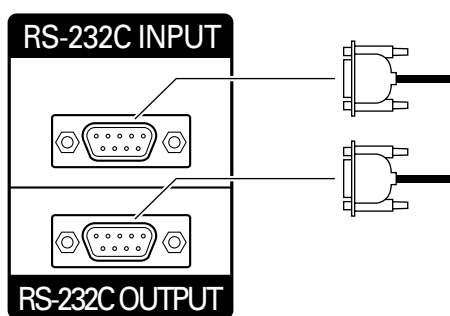

- The RS-232C INPUT and RS-232C OUTPUT are used to control this monitor with a PC.  
To connect a single monitor to a PC, connect to the RS-232C INPUT terminal.  
To connect multiple monitors in a daisy chain for control by PC, use the RS-232C OUTPUT terminal.

# Connecting External Speakers

## ▼ Rear view

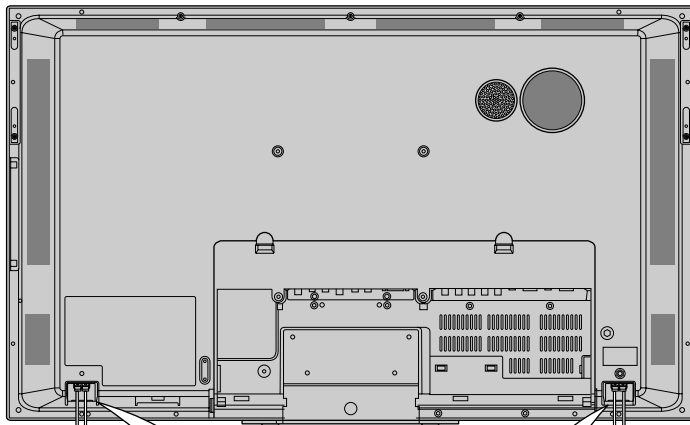

To external speaker (right)

To external speaker (left)

## ▼ SPEAKER R terminal

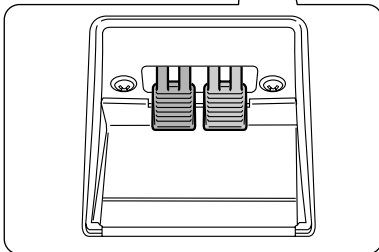

## ▼ SPEAKER L terminal

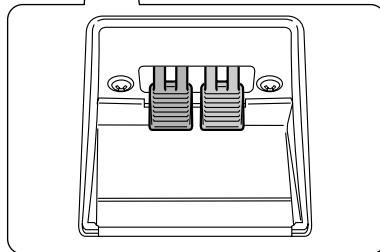

## Speaker compatibility:

- Be sure to use external speakers with an impedance of 8 ohm and a rated input of at least 10W.

## How to connect the speaker cables

1 Pull up the lid.



2 Insert the edge of the cable.

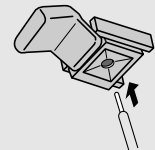

3 Put the lid back down.



## Make sure to connect the speaker jack and cable polarity (+, -) properly.

- The speaker jacks have plus (+) and minus (-) polarity. Plus is red and minus is black. The cables are also divided into plus and minus. When connecting the left/right speakers, be sure to connect the plus/minus jacks with the correct cables.

 NOTE:

- You can output audio from the built-in monitor speaker on the back of the monitor. See "Monitor Speaker Output" on page 57 for details.

# Connecting the AC Cord

**Caution** Be sure to turn the main POWER off when connecting the cord.

## ▼Rear view

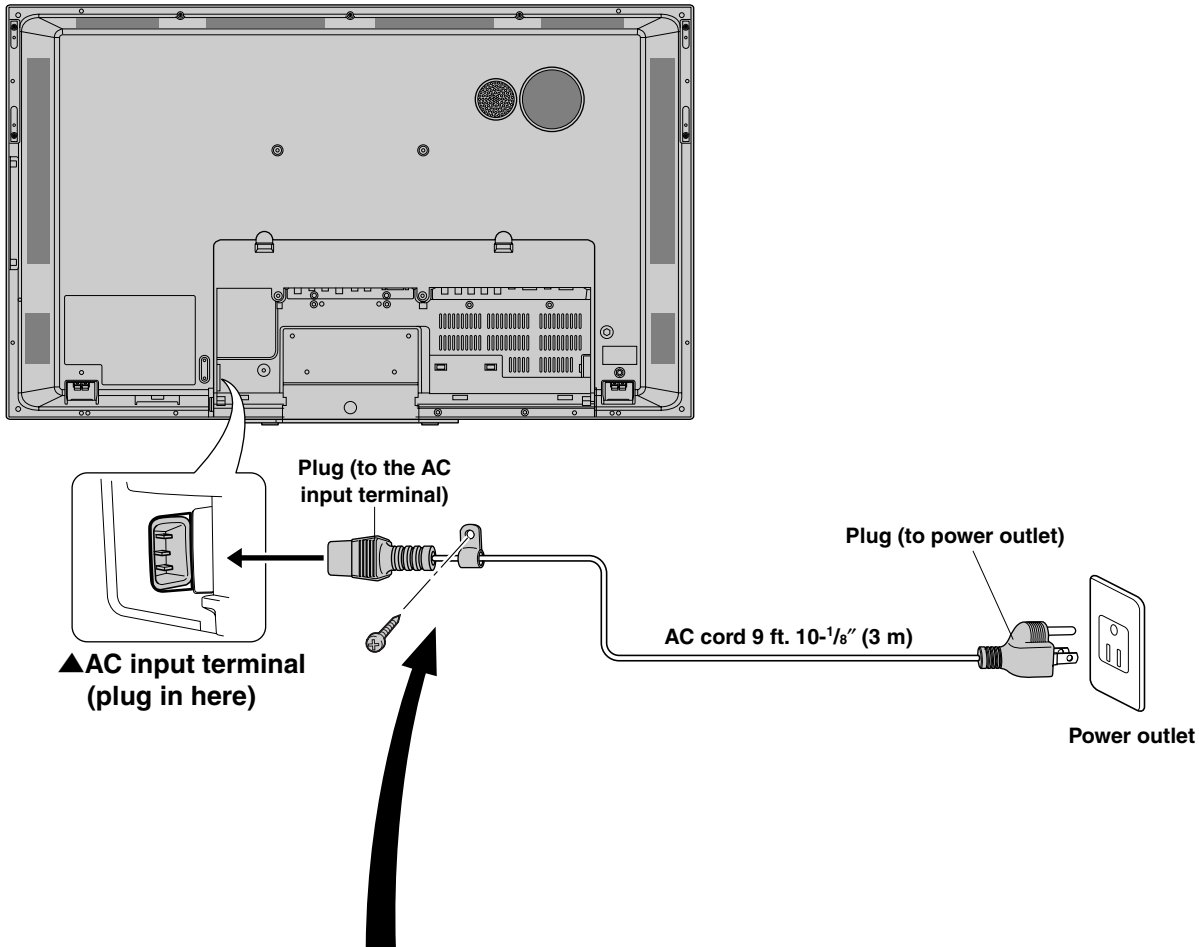

Connection and Installation

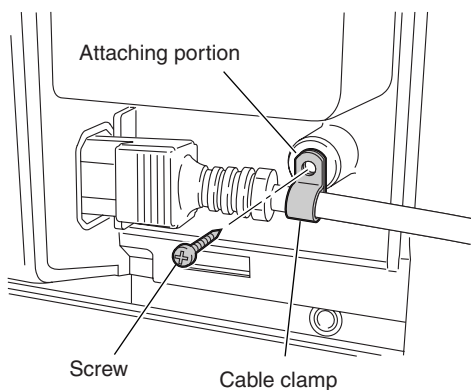

## Fastening the AC cord

1. Plug the AC cord into the AC input terminal on the back of the monitor.
  - Align the shape of the plug and the connector, and insert all the way in.
2. Attach the supplied cable clamp to the AC cord.
3. Align the hole of the cable clamp with the screw hole on the monitor, and fasten the cable clamp screw.
4. Plug the AC cord into the AC power outlet.
  - Be sure to plug all the way into the socket.

**NOTE:**

- When connecting the power cord to the main unit, always use the cable clamp to keep the power cord from coming loose.

# Connecting Multiple Monitors

- Multiple monitors can be connected in a daisy chain using the input/output terminals for video/audio signals.

## Connection examples for video only

Example: 1

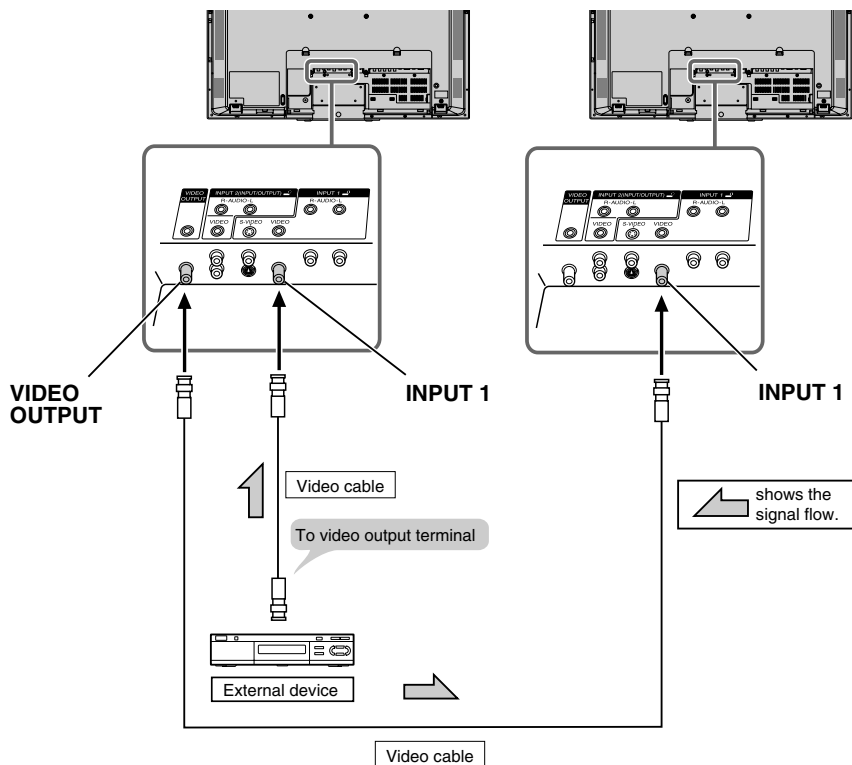

Example: 2

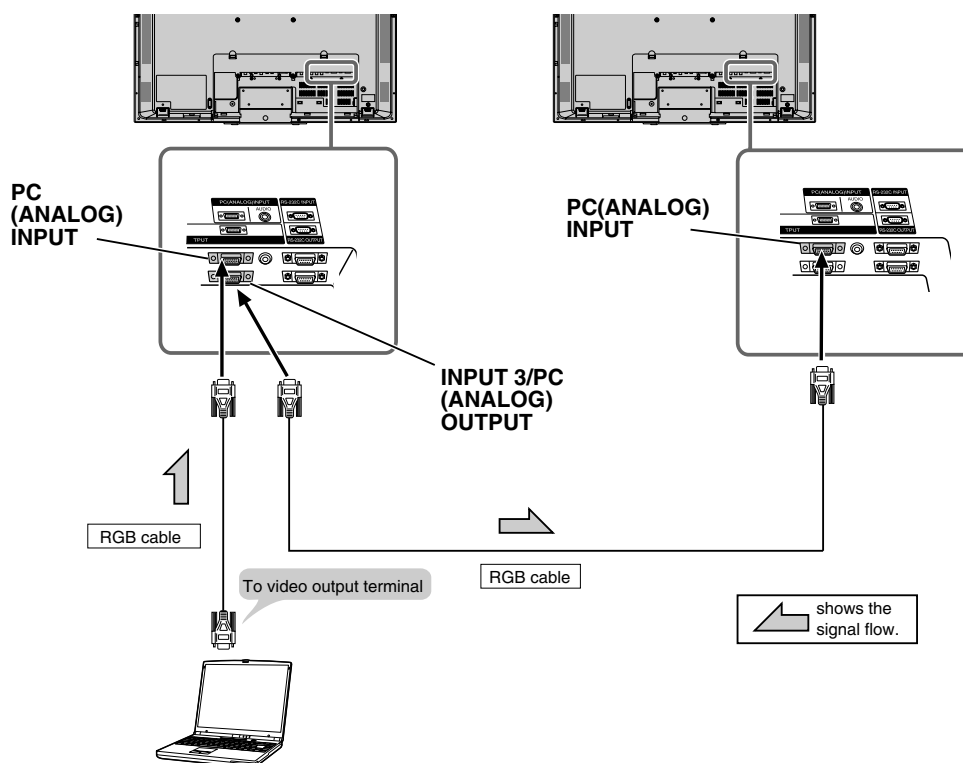

## Connection examples for video and audio

**56** Use by selecting "INPUT2 Select" and setting INPUT2 to "Output".

Example: 1

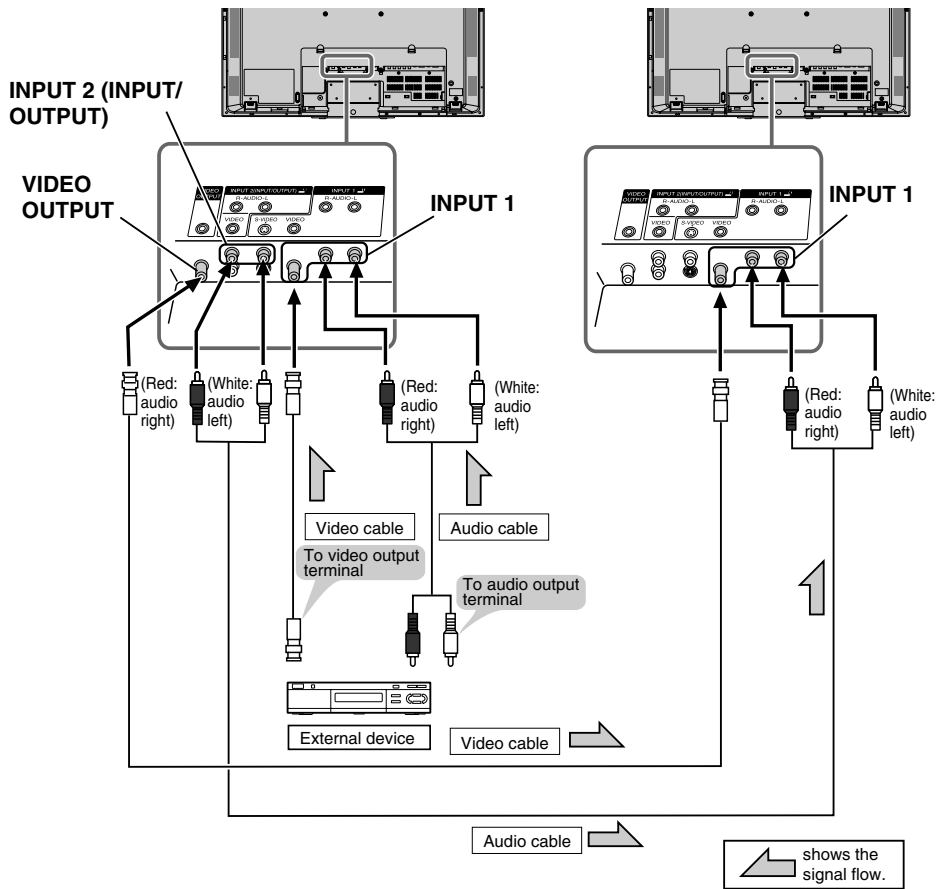

Example: 2

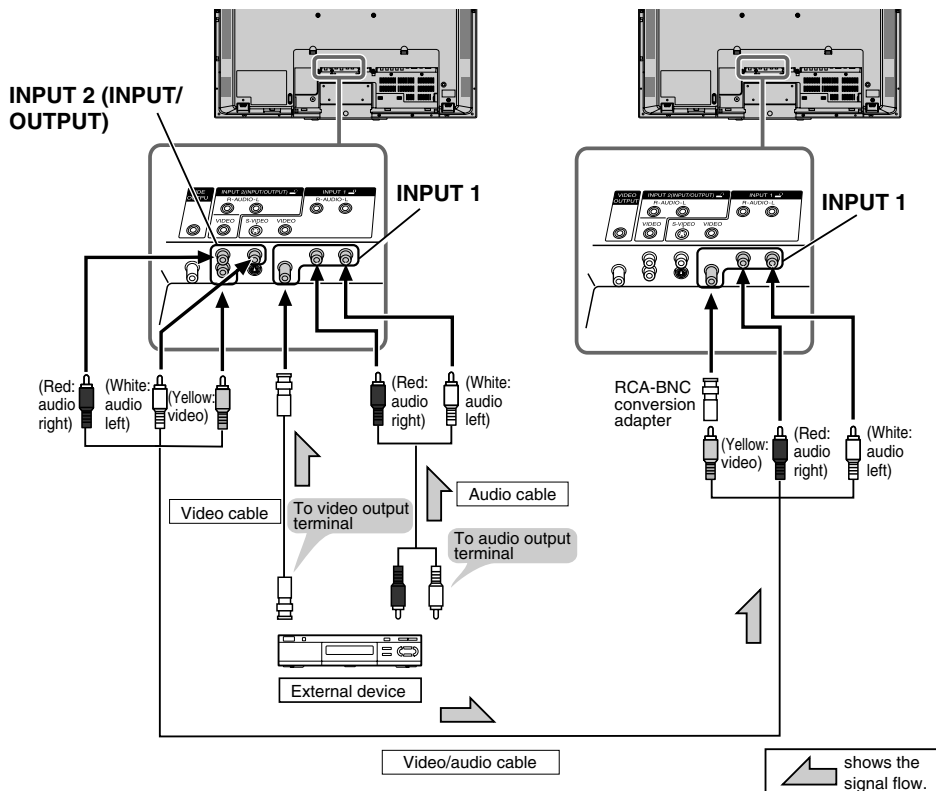

# Connecting Multiple Monitors (Continued)

**56** Use by selecting "INPUT2 Select" and setting INPUT2 to "Output".

Example: 3

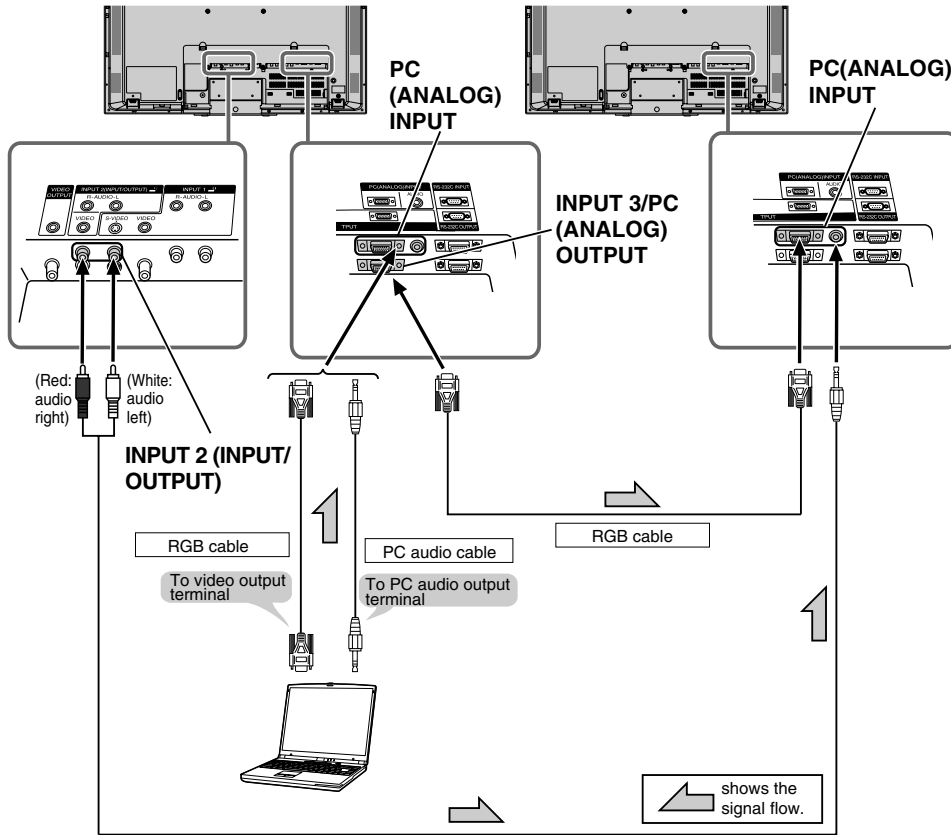

Monitors can be externally controlled using the RS-232C interface (COM port) of a PC, and, in this case too, multiple monitors can be connected in a daisy chain. By assigning each monitor an ID number (see page 56), you can perform input switching, adjustment and status monitoring of individual monitors.

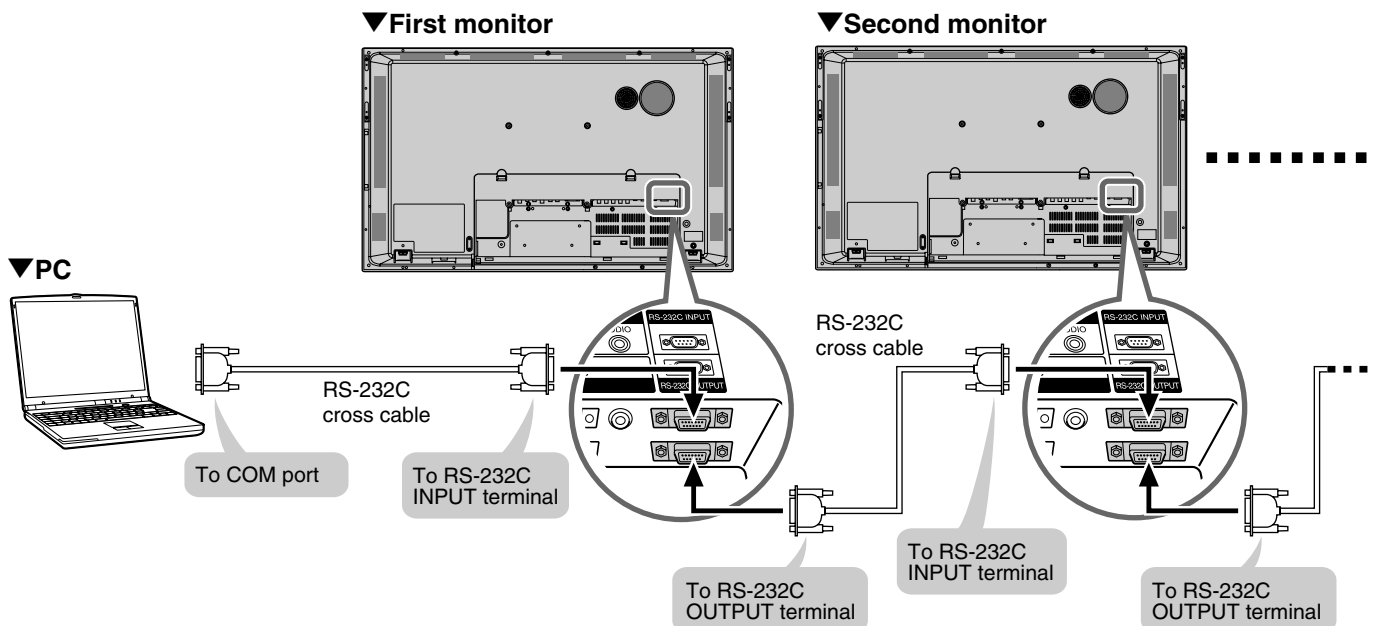

Related topic:

**37** PC Operation

- Please use an optional table stand or wall-mount bracket designed specifically for this product.

## Mounting precautions

This monitor is equipped with a temporary stand when shipped from the factory. Please note this stand is for temporary use only until the monitor is properly mounted. Be sure to use a special-purpose AN-37ST1 table stand or AN-37AG1 wall-mount bracket (both optional).

## Mounting the table stand (AN-37ST1) (LC-M3700)

See the table stand instructions for details.

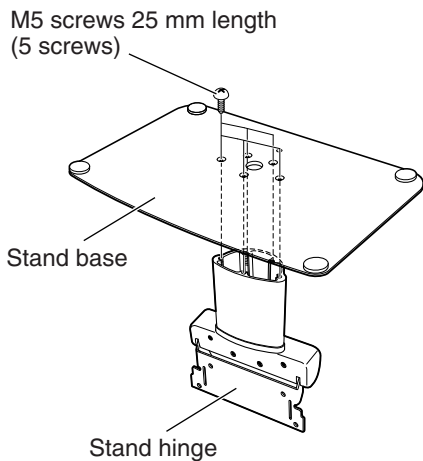

### 1. Assemble the table stand.

- Align the 5 screw holes of the stand base with the corresponding screw holes of the stand hinge. Then attach the stand base to the stand hinge using the supplied 5 screws (M5 25 mm length).

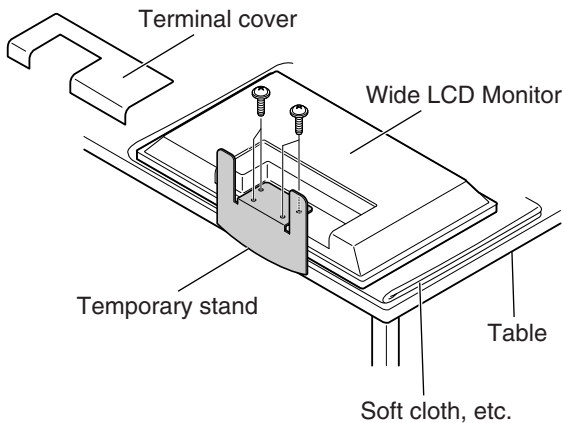

### 2. Detach the temporary stand.

- Place the monitor (face down) on a table, etc. covered by a thick, soft cloth for LCD panel protection.
- Position the monitor near the edge of the table so that the temporary stand does not hit the table, then remove the terminal cover.
- Unfasten the 4 screws used to secure the temporary stand in place, then remove the stand.

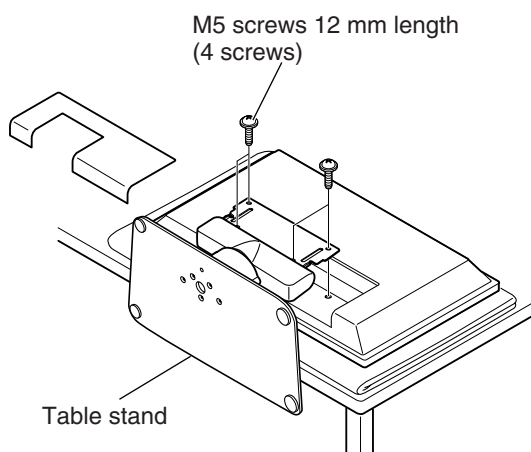

### 3. Attach the table stand assembled in step 1 to the back of the monitor using the supplied 4 screws (M5 12 mm length).

- After installation, close the terminal cover, and adjust the monitor to a suitable angle. (Tilting range: up to 4° forward and 6° backward. Rotating range: up to 10° clockwise and anticlockwise.)



## Mounting Options (Continued)

# AN-37AG1 Wall-Mount Bracket Installation

See the bracket instructions for details.

### Mounting precautions

Special techniques are required to mount this monitor, so be sure to rely on a specialist for mounting work. The customer should never perform any of this work himself or herself. Our company will bear no responsibility for accidents or injuries caused by improper mounting or handling.

## Installing wall-mount bracket

### 1. Determine the location where the base bracket will be installed.

- Take a washer about the size of a coin with a string and align it perpendicular to the base bracket.
- Use a pencil, etc., to mark the two screw hole locations.

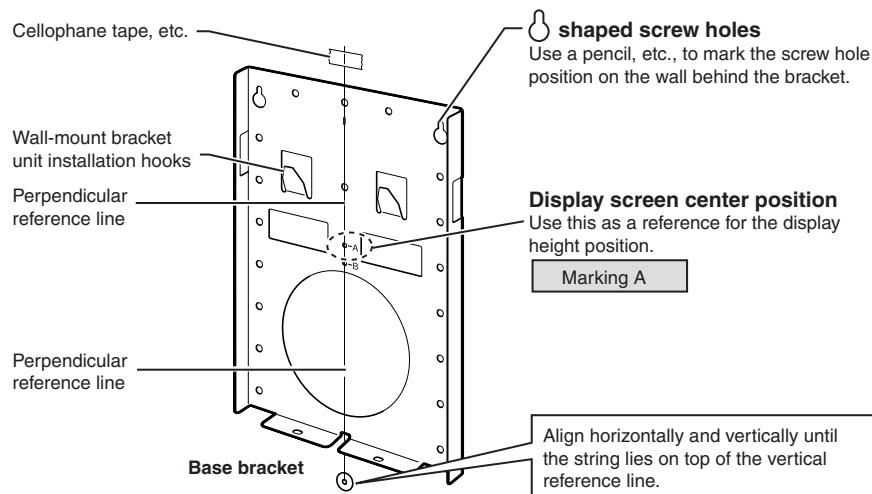

### 2. Loosely screw in the screws.

- Temporarily remove the base bracket from the wall and loosely screw in 2 off-the-shelf screws in the screw hole positions marked on the wall. At this time, the screw heads should extend several millimeters above the wall so that the base bracket can be hung on the screw heads.
- Hang the base bracket on the installed screws, check to make sure the bracket is not sagging to the left or right, and then firmly tighten the screws. Use off-the-shelf screws to secure the remaining screw holes (14 to 18 screws).

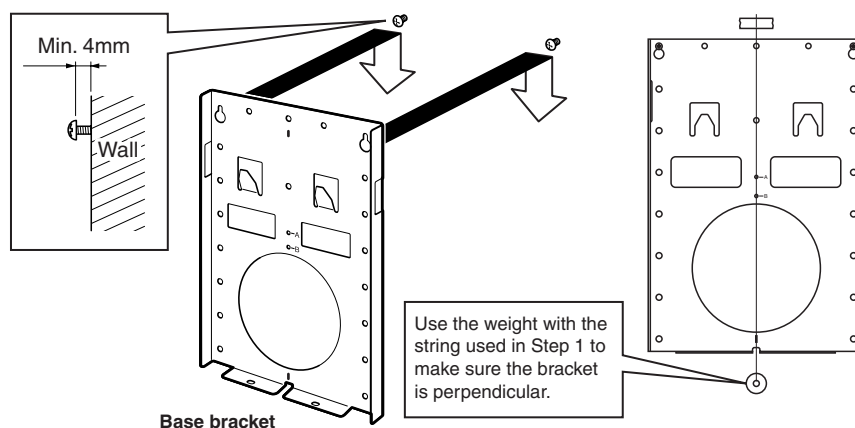

## Setting the angle of the wall-mount bracket

- The wall-mount bracket is assembled for perpendicular installation, so to use it for tilted installation, please follow the procedure below to set it at the installation angle.

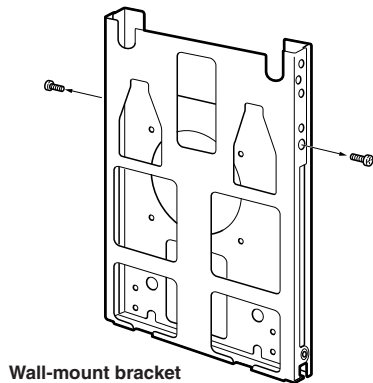

### Setting the installation angle.

- ① Remove the 2 vertical installation screws. These screws are used when setting the angle in step 3.
- ② Assemble the wall-mount bracket as desired as shown in the figure. (Figure shows a 20° angle.)
- ③ Use the screws removed in Step 1 (M6 15 mm length × 2 screws) and the included screws M6 15 mm length × 2 screws to loosely fasten the angle-setup bracket with 4 screws. Firmly tighten these 4 screws after the angle-setup bracket position has been determined.



- When setting the angle of the wall-mount bracket, be careful not to pinch your fingers, etc.

### Installation angle:

LC-M3700 (Horizontal mount)	0° to 20°
LC-M3710 (Vertical mount)	0°

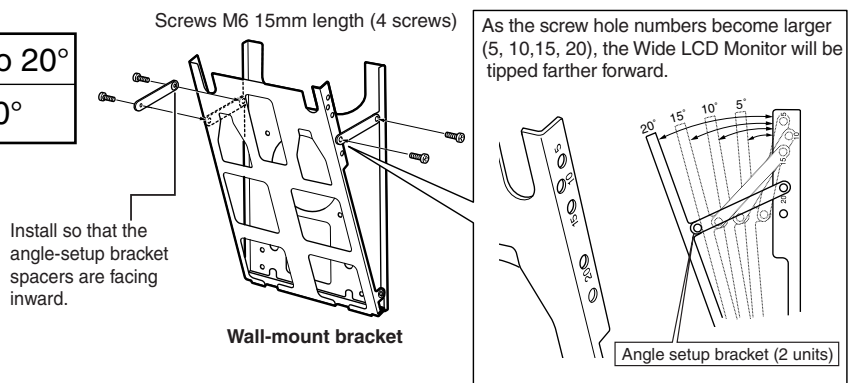

## Attaching wall-mount bracket to the monitor

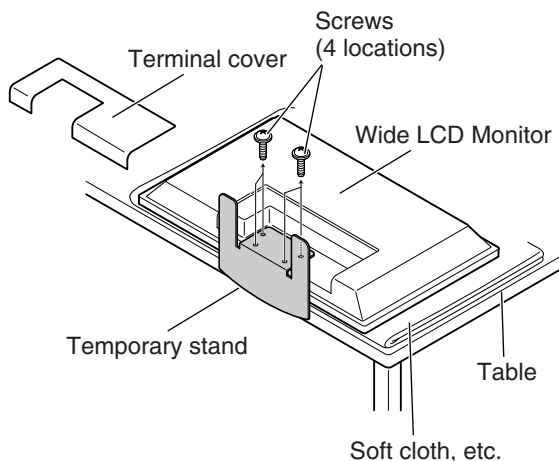

### 1. Detach the temporary stand.

- Place the monitor (face down) on a table, etc. covered by a thick, soft cloth for LCD panel protection.
- Position the monitor near the edge of the table so that the temporary stand does not hit the table, then remove the terminal cover.
- Unfasten the 4 screws used to secure the temporary stand in place.

## Mounting Options (Continued)

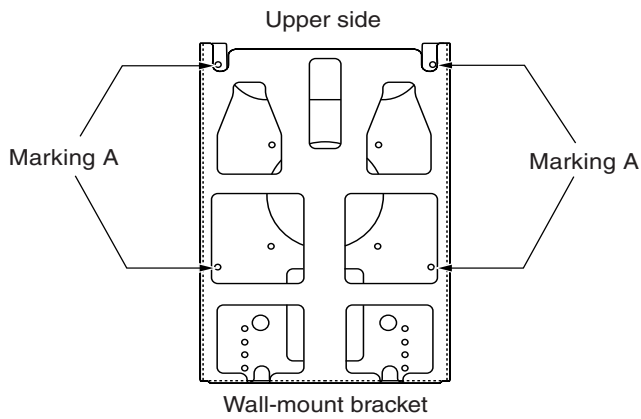

Attaching wall-mount bracket to LC-M3700 (horizontal mount)

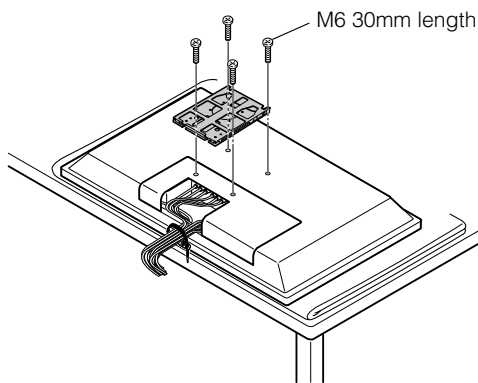

## 2. Attach the wall-mount bracket (with the angle set) to the back of the Wide LCD Monitor.

- Make sure all cables and cords are connected and bundled (see page 29).
- Attach the terminal cover to the back of the monitor and align the wall-mount screw holes (Marking A: 4 locations) with the holes (4 locations) on the back of the Wide LCD Monitor.
- Use the supplied M6 30 mm length screws (4 screws) to securely fasten the wall-mount bracket in place.

Attaching wall-mount bracket to LC-M3710 (vertical mount)

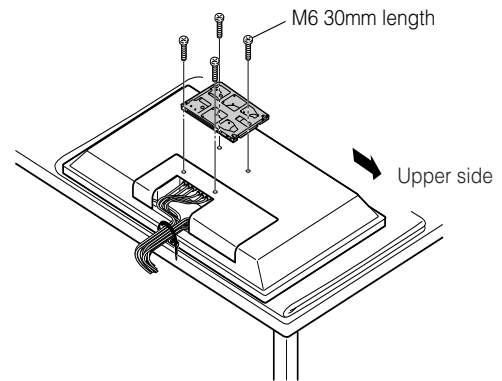

## Mounting the Wide LCD Monitor



- Be sure to use 2 people when installing the Wide LCD Monitor to the base bracket.
- Be sure to perform Steps **A** and **B** below. Just performing Step **A** could result in the display falling off, which is very dangerous.

### Install the wall-mount bracket attached to the Wide LCD Monitor to the base bracket.

- A** Hang the square holes (□) of the wall-mount bracket on the hooks (page 24) of the base bracket.
- B** Tighten the wall-mount bracket and base bracket screws. (Be sure to do this.)

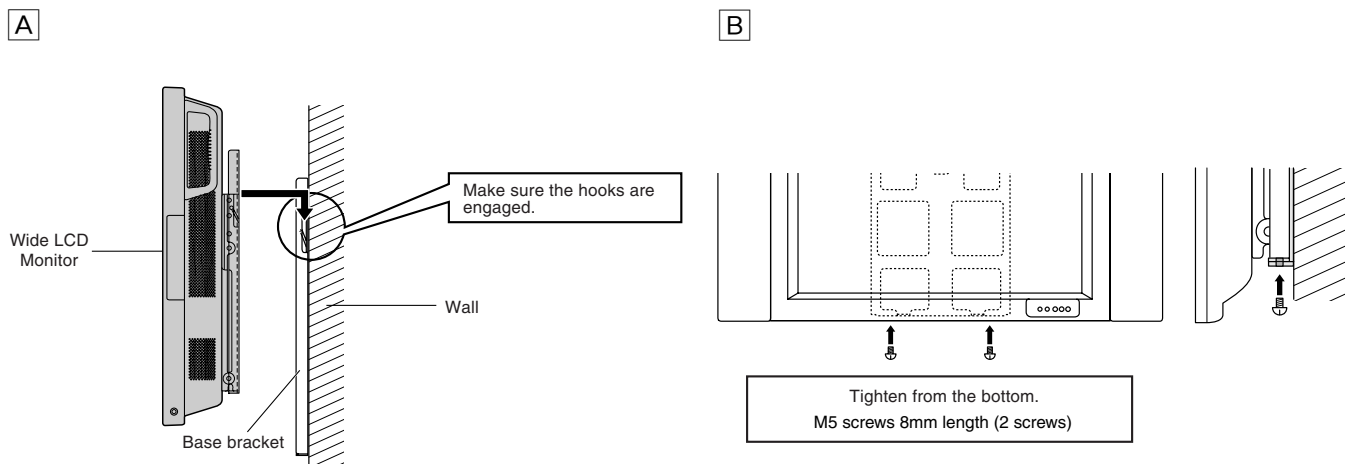

## Outside dimensional drawings

- With table stand attached

Unit: inch [mm]

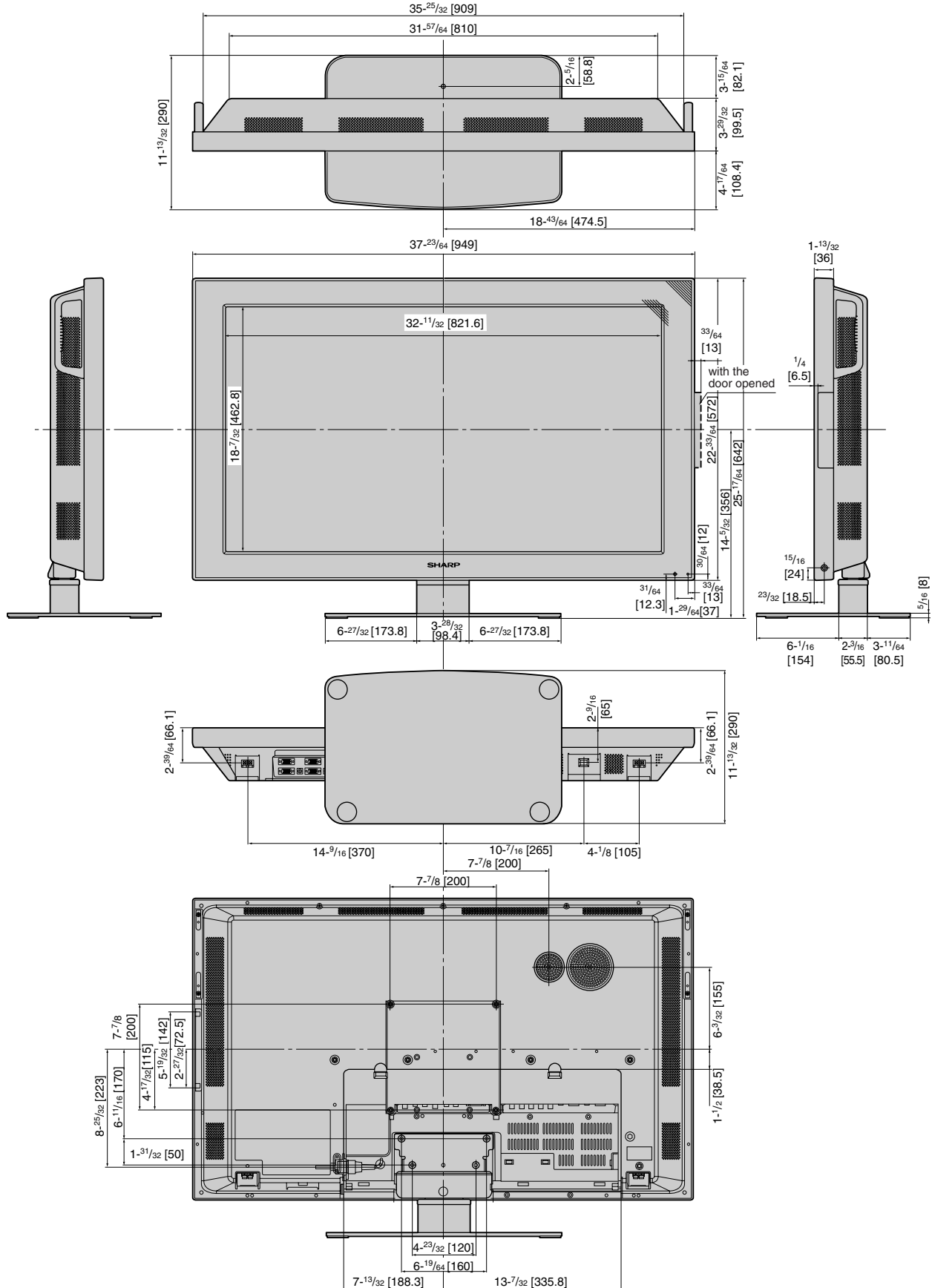

# Mounting Options (Continued)

## Outside dimensional drawings

- With wall-mount bracket attached

Unit: inch [mm]

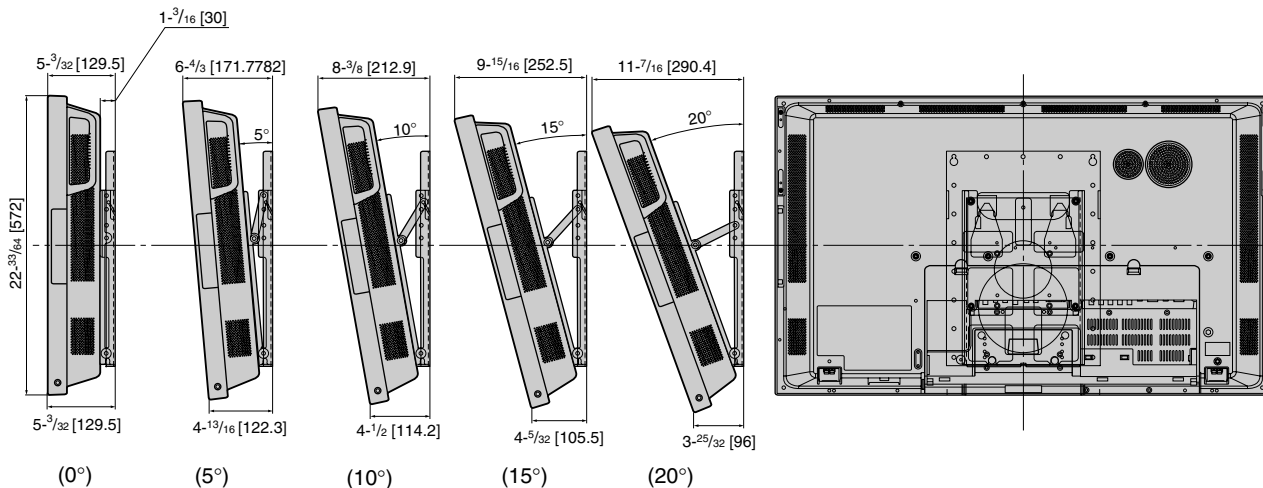

LC-M3700 (Horizontal mount)

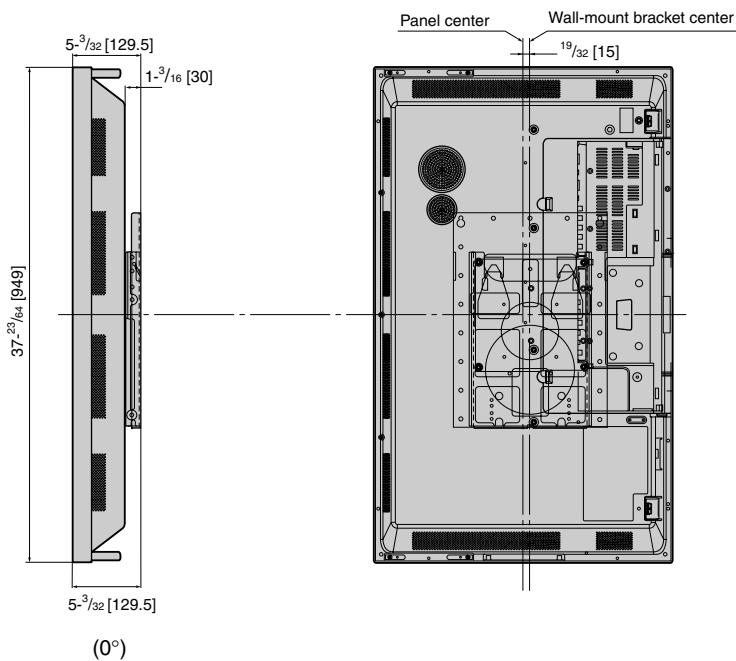

LC-M3710 (Vertical mount)

# Bundling Cables

- Cables and cords connected to the back of the monitor can be bundled using the supplied cable clamp and cable binders. This will prevent stray or disorganized cables at the back of the monitor.

## ▼Rear view

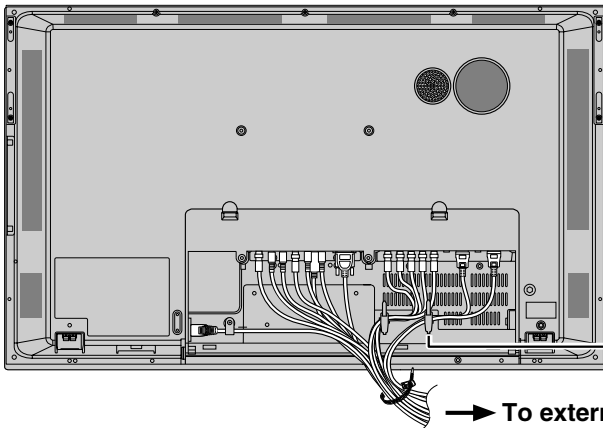

### Cable binder

Wrap the cable binder around the bundle of cables.

Put the thinner end of cable binder through the hole as shown, and tighten appropriately.

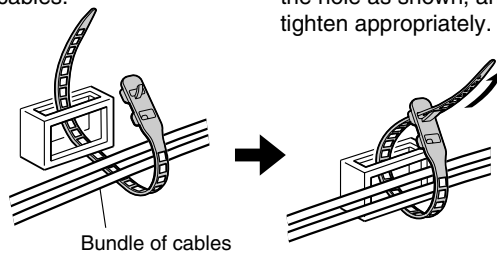

## ▼With terminal cover closed

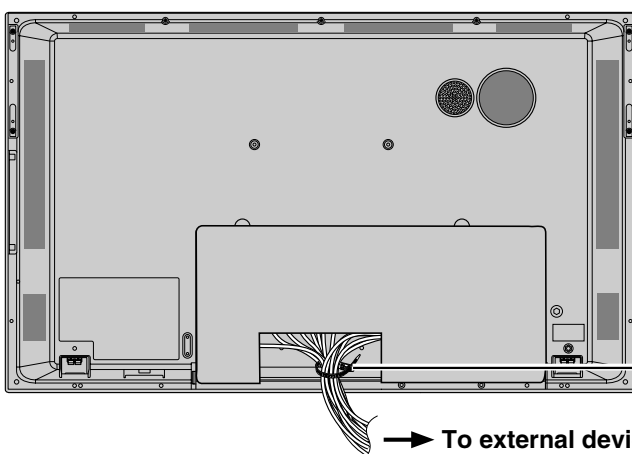

### Cable binder

Wrap the cable binder around the bundle of cables.

Put the thinner end of cable binder through the hole as shown, and tighten appropriately.

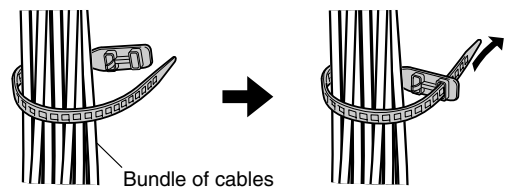

## How to use the supplied terminal cover mounting screws and flat washers

- Use terminal cover mounting screws to firmly fix the terminal cover if difficult to close after bundling the cables.

# Turning on Power

- Before turning on POWER, make sure that peripherals, external speakers, and the AC cord are connected properly.
- There are two power supply switches: POWER (main power supply) and STANDBY/ON.

## Main POWER switch

### ▼Rear view

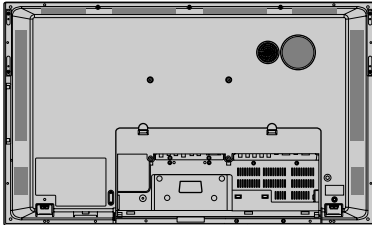

### ▼Front view

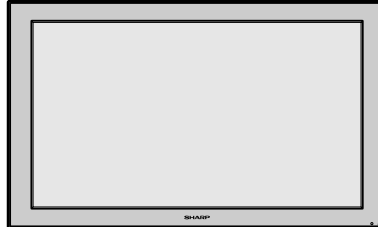

STANDBY/ON indicator

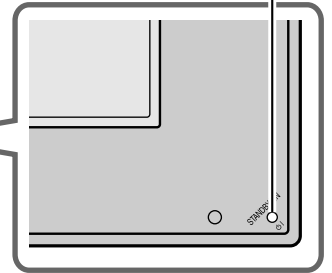

### ▼POWER (main) switch

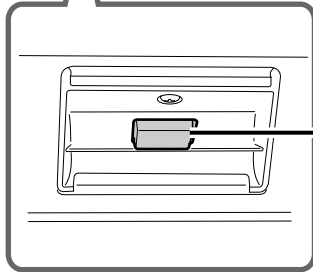

**PRESS POWER (MAIN) ON THE BACK OF THE MONITOR.**

- The STANDBY/ON indicator at the lower-right corner of LCD panel lights up green.

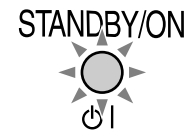

- Please note that STANDBY/ON will not turn power on if the main POWER is not switched ON.

## STANDBY/ON

### ▼Remote control unit

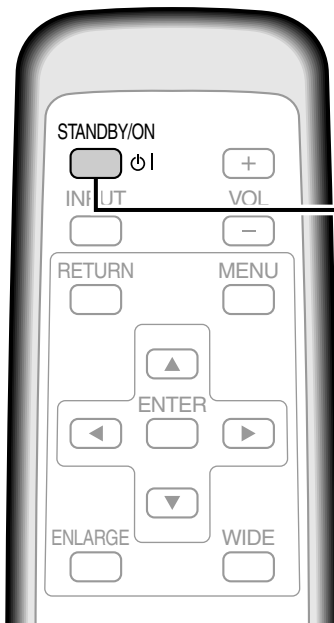

**PRESS STANDBY/ON TO TURN THE POWER ON/OFF.**

Power "On": STANDBY/ON indicator lights up green.

Power "Off": STANDBY/ON indicator lights up red.

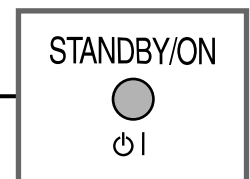
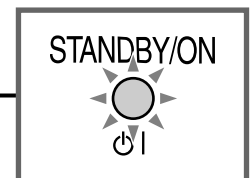

- Generally the monitor is operated using the remote control unit once main POWER on the back of the monitor has been turned on.

**INPUT (Input selection)**

Press INPUT to display the input selection screen. Press INPUT or use ▲/▼ (Cursor control) to select the input mode.

- In INPUT1 or PC mode, the video selected in “Input Select” (page 54) is displayed on the screen.
- INPUT2 can be selected only when it has been set to “Input” in “INPUT2 Select” (see page 56).

INPUT1 ↔ INPUT2 ↔ INPUT3 ↔ PC

**VOL (Volume adjustment)**

Press **+** to increase the volume, and **-** to decrease the volume.  
Sound is muted when volume is set to “0”.  
Each input terminal has its own volume output setting.

**ENLARGE**

The display toggles as shown below, based on the setting on the menu screen.

Off → 2 × 2 → 3 × 3

**56** **61** Enlarge

**WIDE (Screen size selection)**

Press WIDE to display the “Wide Mode” menu screen. Press WIDE or use ▲/▼ (Cursor control) to select the screen size.  
The screen sizes which can be selected vary depending on the type of video signal.

**57** **62**



# Menu Items

■ Menus can be displayed on the screen to enable video and audio adjustment, and setting of various functions, using the remote control. For details refer to the pages where each topic is explained.

## Menu option selection

### Buttons used in menu operation

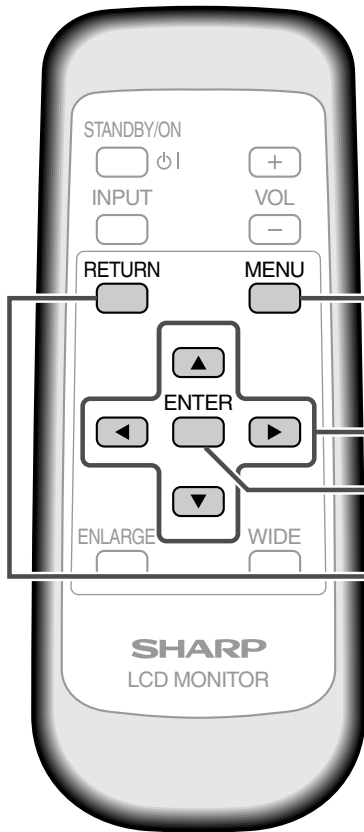

#### MENU

- Displays and turns off the menu screen.

#### UP/DOWN/LEFT/RIGHT (Cursor control)

- ▲/▼/◀/▶: Selects a desired item on the screen.
  - ◀/▶: Adjusts a selected item.
- Pressing ▶ increases a numerical value.  
Pressing ◀ decreases a numerical value.

#### ENTER

- Continues to next step.
- Determines the selected item.

#### RETURN

- Returns to the previous menu screen.

Example of menu operation: Adjusting “Position” in “Setup”.

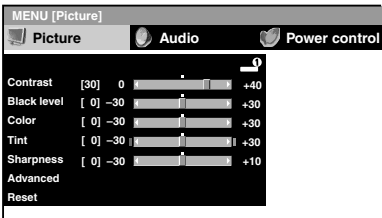
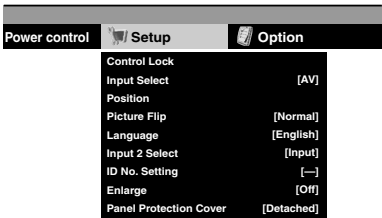
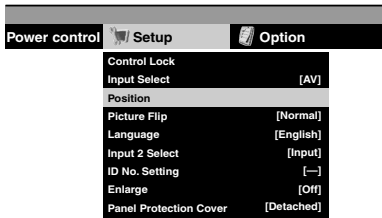
<p><b>1</b> Press <b>MENU</b> and the menu screen displays.</p> 	<p><b>2</b> Press <b>▶</b> (or <b>◀</b>) to select “Setup”.</p> 	<p><b>3</b> Press <b>▼</b> (or <b>▲</b>) to select “Position”, and then press <b>ENTER</b>.</p>  <ul style="list-style-type: none"> <li>• The position menu screen is displayed.</li> </ul>
---	--	--



• Due to the type of signal and its frequency, the items in the menu screen appear differently.

## Menu screen explanation

▼ Menu screen example (partial)

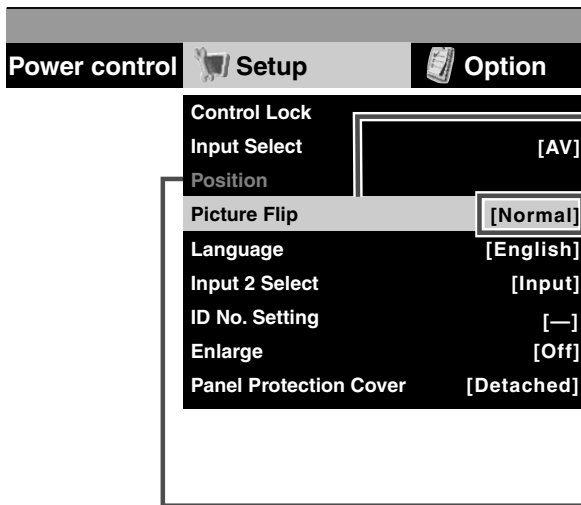

- Item displayed in yellow
  - This indicates item currently selected.
  - Press ENTER to go to the adjustment screen for this item.
- Item in brackets
  - This shows the current setting for the item.
- Items displayed in white
  - This indicates that an item can be selected.
- Item displayed with gray characters
  - These items cannot be selected.
    - \* There are various reasons why items cannot be selected, but the main reasons are as follows:
      1. There is no signal.
      2. The function is not compatible with the current input signal.

Most picture adjustment options cannot be selected in the following states:

1. When "Underscan" is selected in "Wide Mode".
2. With a PC (digital) signal.

## Operation guide

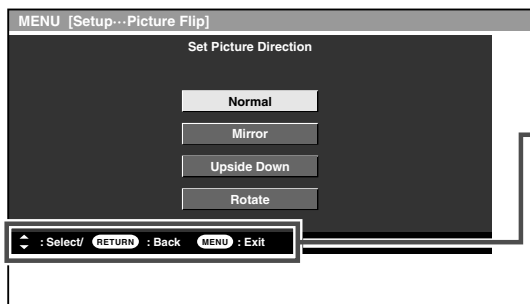

- This shows the remote control buttons which can be used with the currently displayed screen, and their functions.
  - Operate by following this operation guide.

## Menu screen duration

- The menu screen will revert to the normal screen if there is no operation for 1 minute while the menu screen is displayed.

## Language setting

- The On-Screen Display language can be set to Japanese, English, German, French or Spanish. See page 36 for details.



- Menu options differ between the AV and PC modes, but operating procedures are the same.
- The menu item illustrations in this operation manual are for explanation purposes (some are enlarged; others cropped) and may vary slightly from the actual displays.

## Menu Items (Continued)

### PC (analog) input mode menu items

INPUT3 : RGB

PC : Analog

PC : Digital

For a table of adjustment ranges for each menu item, please see **Appendix3** on page **70**.

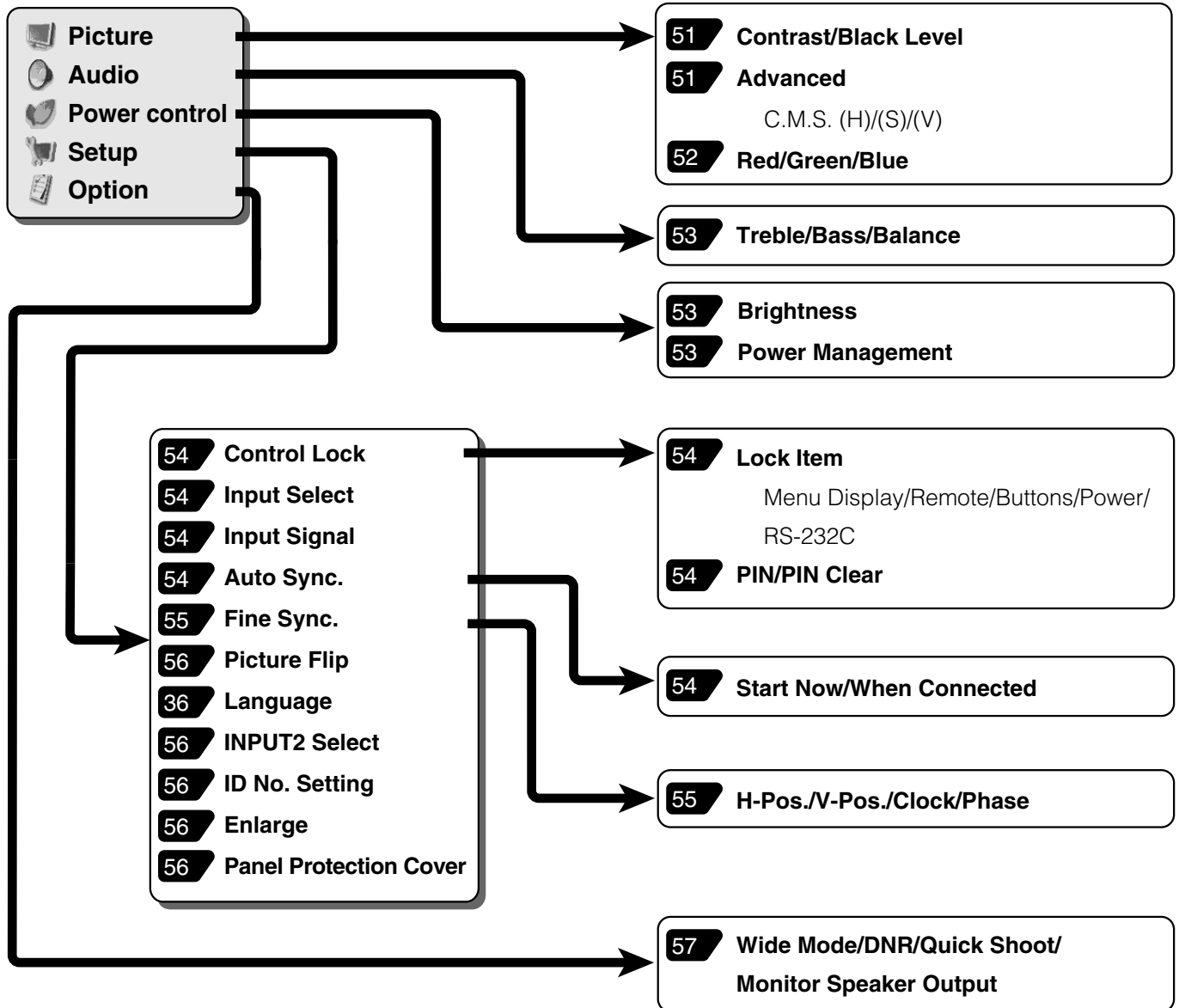

#### NOTE:

- Due to the type of signal and its frequency, some items are not selectable and grayed out.
- "C.M.S." is the only picture adjustment item which can be used with PC (digital) signals.
- "Fine Sync." (position adjustment etc.) cannot be used with PC (digital) signals.

# AV input mode menu items

INPUT1: AV, Y/C  
 INPUT2:  
 INPUT3: COMPONENT

For a table of adjustment ranges for each menu item, please see **Appendix3** on page 71.

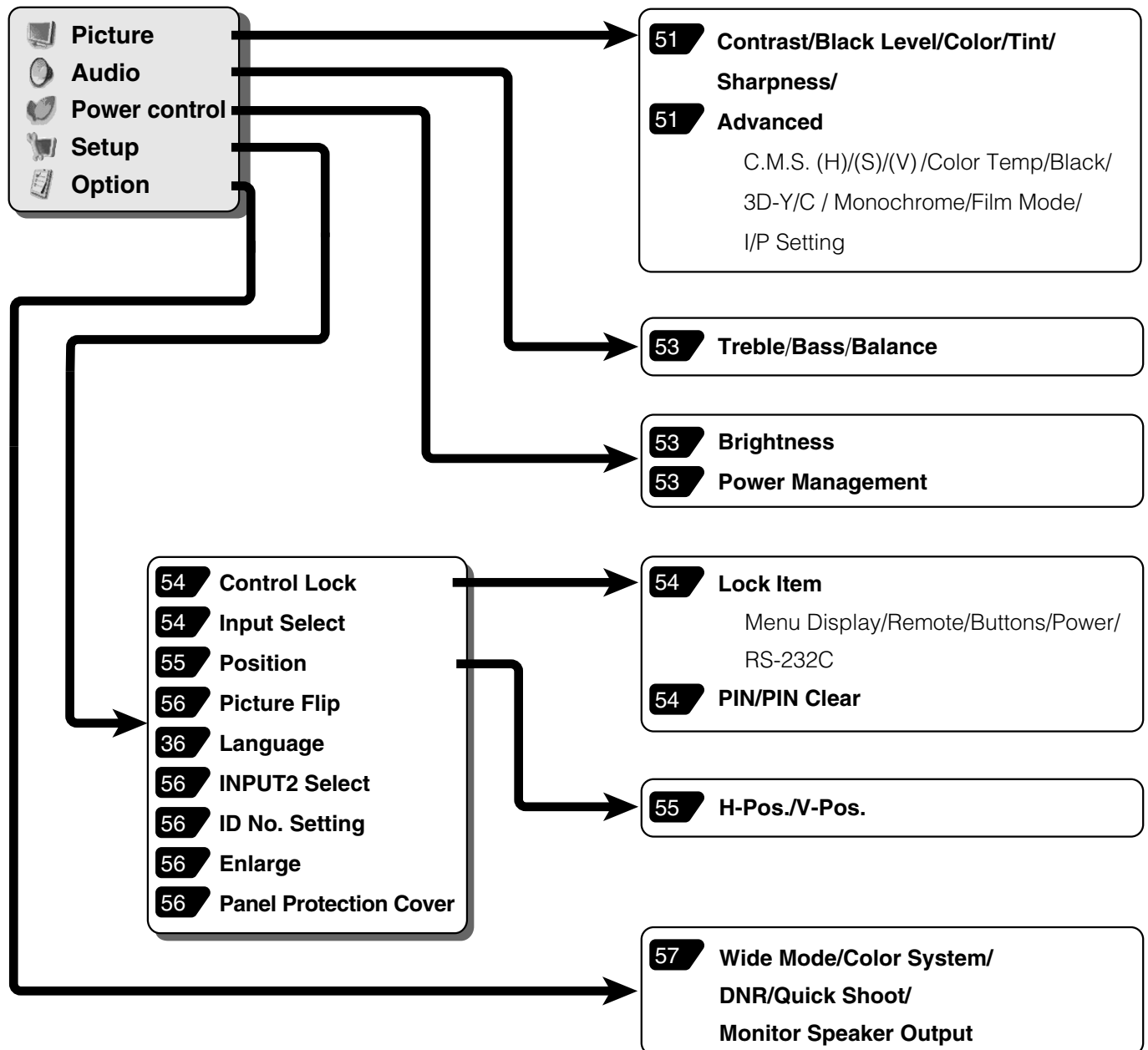

Basic Operation



- "INPUT2 Select" is not displayed when the input mode is set to "INPUT2".
- Due to the type of signal and its frequency, some items are not selectable and grayed out.
- If "Underscan" has been selected in "Wide Mode", most picture adjustment items cannot be used (except for some settings in "Advanced").

## Menu Items (Continued)

### Language setting

- The On-Screen Display language can be set to Japanese, English, German, French or Spanish.

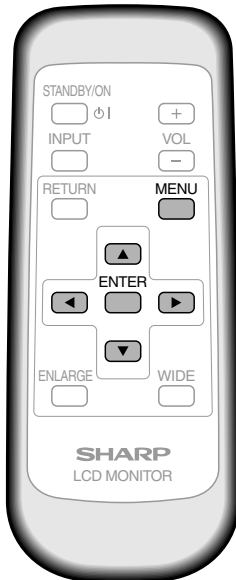

1

- ① Press **MENU** to display the menu screen.
- ② Press **◀** or **▶** to select “Setup”.

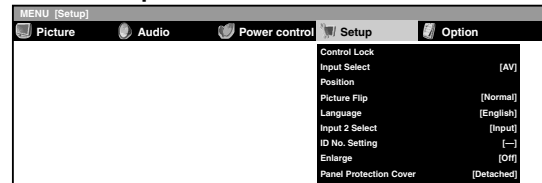

2

- Press **▲** or **▼** to select “Language”, then press **ENTER**.

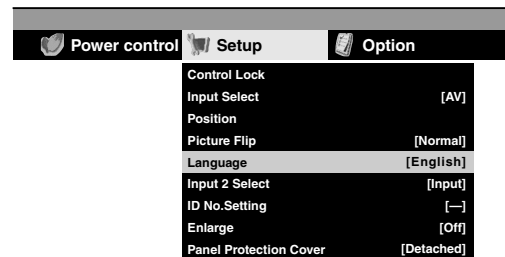

3

- Press **▲** or **▼** to select desired language.



- The menu screen is now displayed in the language selected.

4

- Press **MENU** to return to normal screen.

## PC connection

### 1 One-to-one connection with a PC ..... Basic operation

Connect with RS-232C cross cable between the PC COM port (RS-232C connector) and the RS-232C INPUT terminal on the back of monitor.

#### ▼Rear view

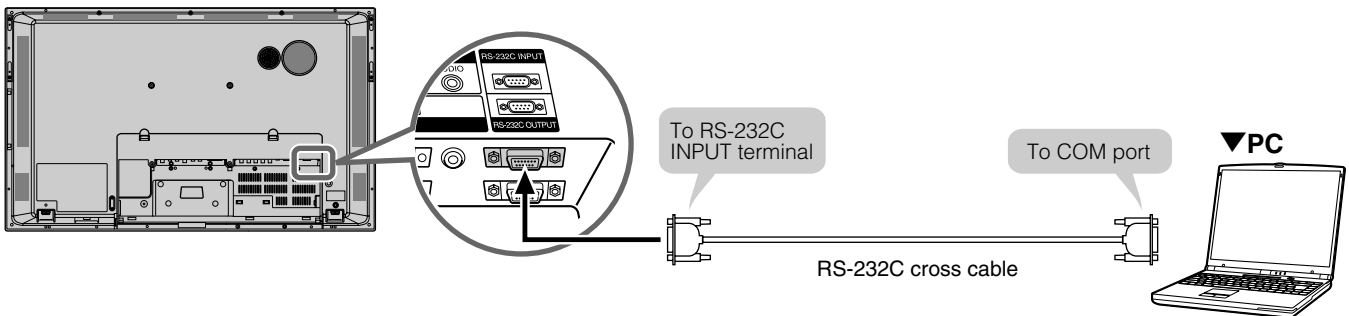

### 2 Daisy chain connection from a single PC ..... Advanced operation

Connect with RS-232C cross cable between the PC COM port (RS-232C connector) and the RS-232C INPUT terminal on the back of monitor.

Next, connect RS-232C cross cable to the first monitor's RS-232C OUTPUT terminal and to second monitor's RS-232C INPUT terminal. Connect in the same way to the third and subsequent monitors. Up to about 20 monitors can be connected, depending on the length of RS-232C cables and installation environment.

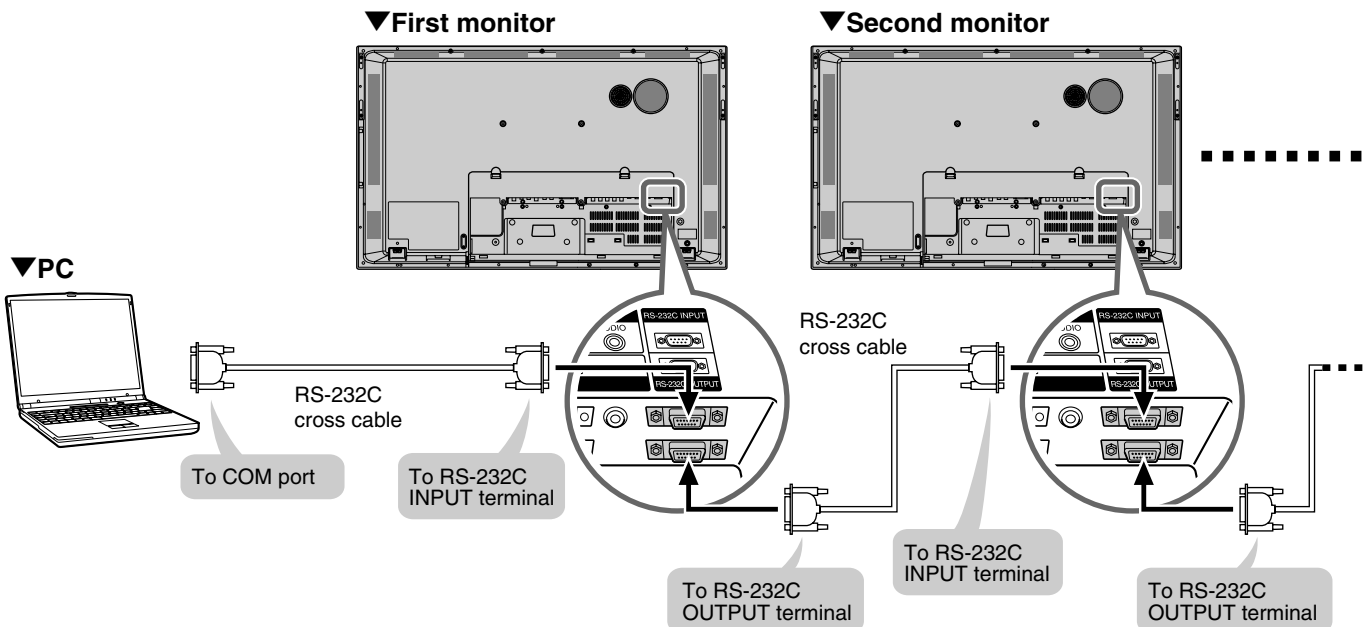

## Communication conditions

- Set the RS-232C communication settings on the PC to match the monitor's communication settings.

Baud rate:	9,600 bps
Data length:	8 bits
Parity bit:	None

Stop bit:	1 bit
Flow control:	None

# Communication procedure

## Basic operation

<Command format>

When a command is sent from the PC to the monitor, the monitor operates according to the received command, and sends a response message to the PC.

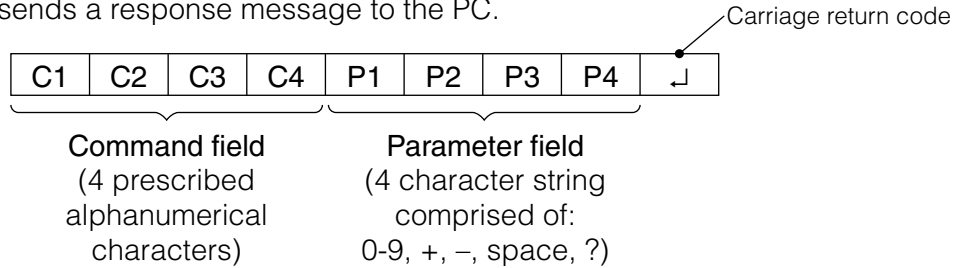

Example: VOLM0030

POWR␣␣␣␣1 ("␣" indicates a space.)

\* Be sure to input 4 characters for the parameter. Pad with spaces if necessary.

× VOLM30␣

○ VOLM␣␣30(␣)(␣) ("␣" indicates a space, "␣" is the carriage return code (0DH, 0AH or 0DH).)

If a command has "R" listed for "Direction" in the "RS-232C Command table" on page 46, the current value can be returned by using "?" as the parameter.

Example: ① If an ID number has not been set:

VOLM???? ←From PC to monitor (current volume setting: ?)

30 ←From monitor to PC (current volume setting: 30)

② If an ID number has been assigned (For example, ID number = 001)

VOLM␣␣␣? ←PC to monitor ("␣" indicates a space)

30␣001 ←Monitor to PC ("␣" indicates a space)

<Response code format>

■ When a command has been executed correctly

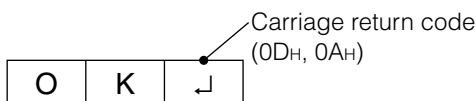

This is returned when execution of the command is finished.

■ When a command has not been executed correctly\*

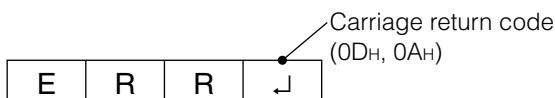

\* This is returned when there is no such command, or when the command cannot be used in the current state of the monitor (i.e. video auto-adjustment with video display).

\* If there is a bad connection between the PC and monitor, or if communication has not been established, nothing is returned (not even ERR).

■ If execution of the command is taking some time

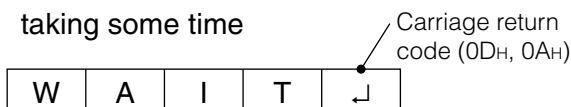

If a command takes some time to execute, WAIT may be returned as the return value. Wait for a moment, and OK or ERR will be returned. New commands cannot be received during this time, even if they are sent.

■ If RS-232C is locked

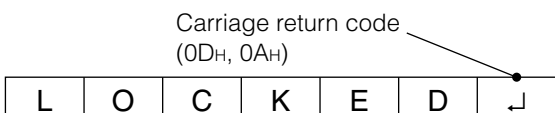

If RS-232C control has been locked with Control lock (see page 54), LOCKED is returned as the returned value.

## Advanced operation

- This section explains commands for daisy chain connection. The basic communication procedure is the same as in the “Basic operation” section.

### <ID numbers>

You can assign a unique ID number to each monitor (see page 56). This allows you to control a particular monitor in a daisy chain of monitors.

Up to about 20 monitors can be connected, depending on the length of RS-232C cables and installation environment.

You can assign ID numbers either from the menu screen (via remote control or the control buttons on the monitor) or from the PC using RS-232C cable.

#### [Example]

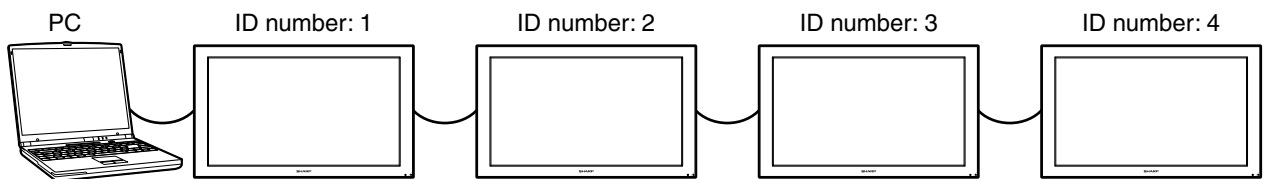

If monitors are connected as shown above, you can execute commands like “Set the volume of the monitor with ID 4 to 20”.

When controlling monitors linked in a daisy chain by designating ID numbers, you should basically avoid any duplication of ID numbers.

If the same ID number is assigned to multiple monitors, only the monitor closest to the PC can be controlled with that ID number.

If monitors are connected as shown below, only the monitor ① can be accessed with ID number 2. Monitor ② cannot be controlled using that ID number.

#### [Example]

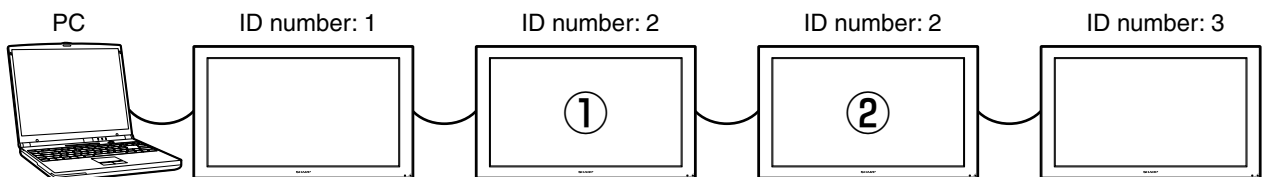

ID numbers do not have to be assigned in ascending order starting from the PC. They can also be connected as shown below.

#### [Example]

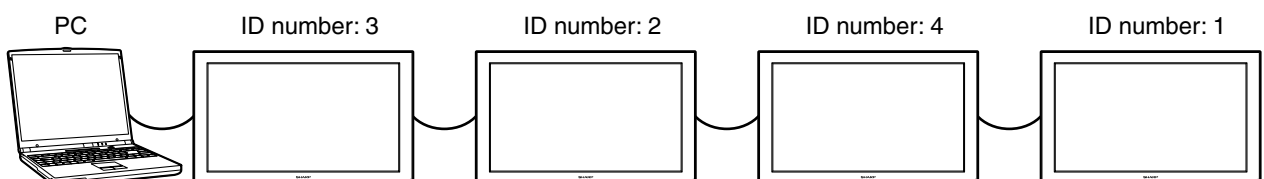



## PC Operation (Continued)

### <Commands for ID control>

The command examples shown on this page assume the following connection and ID number set up.

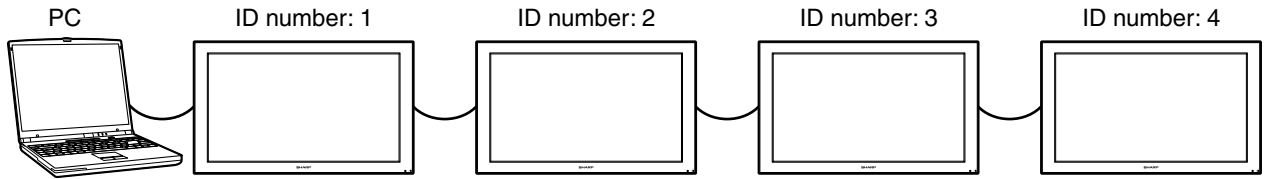

IDST.....A monitor receiving this command sets its own ID number in the parameter field.

Example: IDST0001

OK\_001 ←The ID number of this monitor is set to 1.

### Note

After linking monitors, you can automatically assign ID numbers by using the IDST command with the Repeater control (see “Repeater control” on page 42).

[Example]

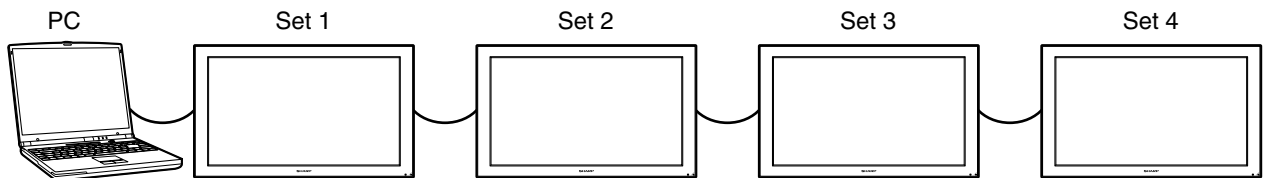

If you connect monitors as shown above, and use the command “IDST001+”, ID numbers will be set automatically, as shown below.

[Example]

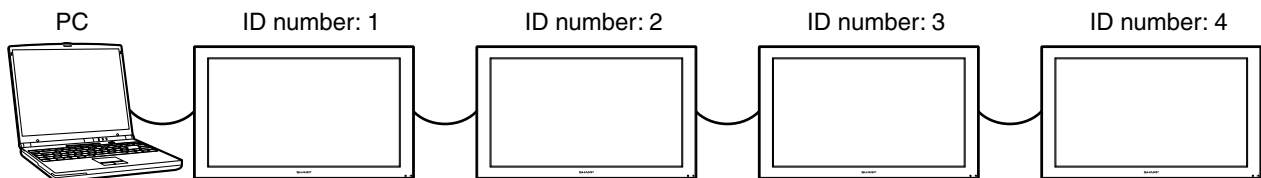

IDST001+      ←ID setting command with repeater control  
WAIT  
OK\_001      ←ID = “OK” response from ID number=1  
OK\_002      ←ID = “OK” response from ID number=2  
OK\_003      ←ID = “OK” response from ID number=3  
OK\_004      ←ID = “OK” response from ID number=4 (End)

**IDSL.....** The parameter of this command sets the ID number indicating the monitor subject to the next command.

**Example:**

IDSL0002	← The next command is for the monitor with ID number=2.	
WAIT	← Searching for monitor with ID number=2.	
OK┐002	← Found monitor with ID number=2	
VOLM0030	← Set volume of monitor with ID number=2 to 30	
WAIT	← Processing	
OK┐002	← OK response from monitor with ID number=2	
VOLM0020	← Set volume to 20	} The IDSL command is effective only once, for the immediately succeeding command.
OK┐001	← The volume of the monitor with ID number=1 (the one directly connected to the PC) is set to 20.	

**IDLK.....** The parameter of this command sets the ID number indicating the monitor subject to all subsequent commands.

**Example:**

IDLK0002	← Following commands are for the monitor whose ID number is "2".	
WAIT	← Searching for monitor with ID number=2.	
OK┐002	← Found monitor with ID number=2	
VOLM0030	← Set volume of monitor with ID number=2 to 30	} The IDLK command remains effective until it is canceled, or power is shut off.
WAIT	← Processing	
OK┐002		
VOLM0020	← Set volume of monitor with ID number=2 to 20	
WAIT		
OK┐002		
IDLK0000	← Canceling ID number setting	
WAIT	← Canceling IDLK	
OK┐002	← Cancelation complete	
VOLM0010		
OK┐001	← The volume of the monitor with ID number=1 (the one directly connected to the PC) is set to 10.	

**IDCK.....** Provides screen display of the ID number currently assigned to a monitor, and the ID number currently set for IDLK (if any).

**Example:**

(After executing IDLK0002)	
IDCK0000	← (Parameter has no meaning)
ID:001 IDLK:002	← Returned response. The ID number is also displayed on the monitor screen.
IDCK000+	← Repeater control
WAIT	(If a command is used with repeater control, ID designation using IDSL or IDLK is canceled.)
ID:001 IDLK:002	
ID:002 IDLK:002	
ID:003 IDLK:002	
ID:004 IDLK:002	

**Continued on the next page.**

# PC Operation (Continued)

## <Repeater control>

This system has a function to allow setting of multiple monitors connected in a daisy chain using a single command. This function is called repeater control.

Up to about 20 monitors can be connected, depending on the length of RS-232C cables and installation environment.

You can use Repeater control function without assigning ID numbers.

[Example]

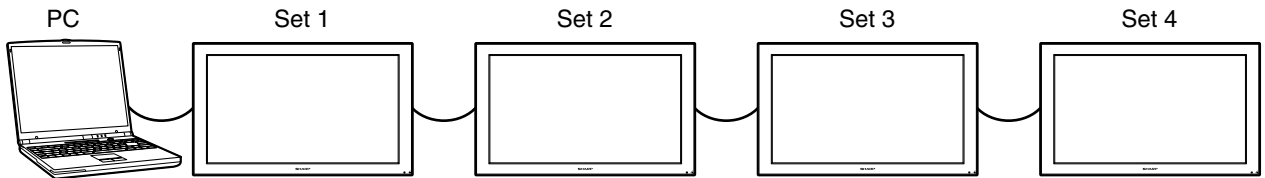

If monitors are connected as shown above, you can execute a command like “Set all monitors’ input settings to INPUT”.

## <Repeater control command>

Repeater control is achieved by setting the **FOURTH CHARACTER** of the parameter to “+”.

**Example:** VOLM030+ ← Sets volume of all monitors to 30.

In repeater control, responses are returned by all the connected monitors.\*

If you want to determine that a value has been returned by a specific set, assign ID numbers to each monitor in advance.

If no response is returned, this may be because the monitor has not received (or is still processing) the command, so it is possible that new commands may not be executed even if they are sent.

\* If power is turned “OFF” using Repeater control, only the monitor closest to the PC returns a response.

**Example:** (When 4 monitors are connected, and assigned ID numbers 1 through 4)

VOLM030+

WAIT

OK\_001

OK\_002

OK\_003

OK\_004

← If 4 monitors are connected in a chain, reliable operation can be ensured by sending a new command only after a reply has been returned by 4th (last) monitor.

Repeater control can also be used for reading settings.

**Example:**

VOLM??#+

WAIT

10\_001

20\_002

30\_003

40\_004

} Volume settings for all monitors are returned.



• If repeater control is used during ID designation (IDSL, IDLK), the ID designation is canceled.

## <Response format in Advanced operation>

### ■ Normal response

① Response when no ID number has been set.

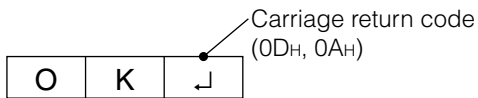

A response is returned when execution of the pertinent command is finished.

② Response when an ID number has been set.

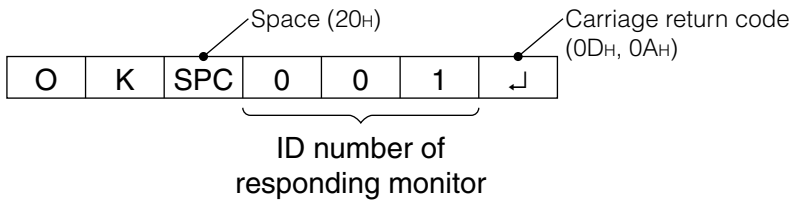

### ■ When a command has not been executed correctly\*

① Response when no ID number has been set.

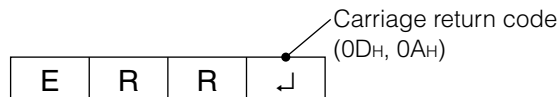

② Response when an ID number has been set.

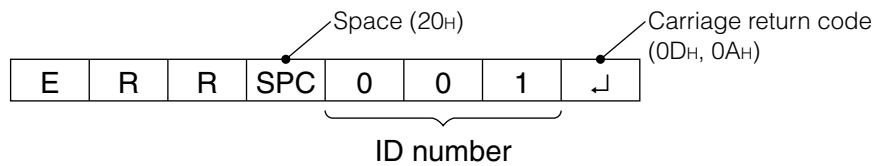

\* This is returned when there is no such command, or when the command cannot be used in the current state of the monitor (i.e. video auto-adjustment with video display).

\* If communication has not been established for reasons like a bad connection with the monitor, nothing is returned (not even ERR).

\* If no monitor has been assigned the designated ID number (e.g. if the command IDSL0002[X] is issued, but no monitor with ID=002 is found), ERR\_XXX[X] is returned.  
(ID number at the furthest end)

### [Example]

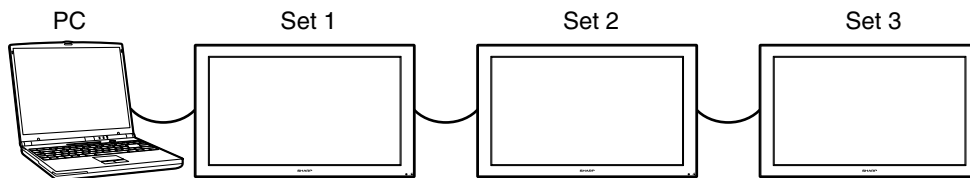

In the above case

IDSL0004↵ ←Non-existent ID number

WAIT↵

ERR\_003↵ ←Monitor with ID=3 at the furthest end returns ERR

## PC Operation (Continued)

- If execution of the command is taking some time.

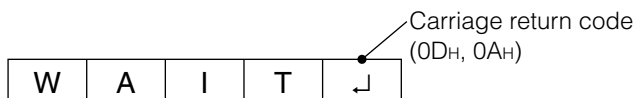

If execution of a command takes some time, WAIT may be returned as the returned value. In this case, a value will be returned if you wait a while. During this time, new commands will not be received, even if they are sent.

No ID number is attached to WAIT response.

- Cases where WAIT is returned
  1. When repeater control is used
  2. When an IDSL or IDLK command is used
  3. When one of the following commands is used: RSET, INP1, INP2, INP3, INPC, INPS, ITGD, IAVD, IPCD, CLSY, ASNC, WIDE, EMAG, EPOS, PXSL, POWER

- When control via RS-232C is locked (to prevent use) using the Control lock function (see page 54).



- If a timeout occurs while waiting for a command

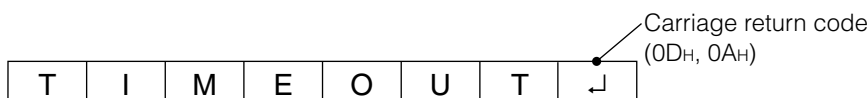

- If a timeout occurs while waiting for a command (when the monitor waiting for the command is assigned an ID number = 001 in the following example)

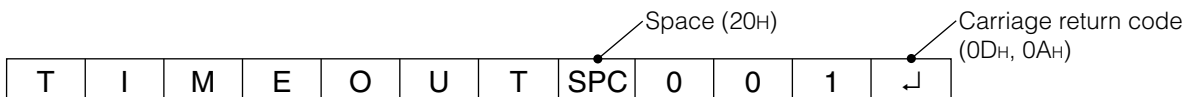

- If the current parameter is read out using "?" for the parameter (for numerical values etc.)

- ① Response when no ID number has been set.

<Example> VOLM????↵  
10↵

- ② Response when an ID number has been set. (In the example below: ID=001)

<Example> VOLM????↵  
10↵001↵

### <Communication interval>

If the next command is sent in the interval before OK or ERR is returned, it will basically be ignored.  
(Exception: Forced end using ASNC command)

Leave an interval of 100 ms between command response and transmission of the next command.  
You can use Repeater control function without assigning ID numbers.

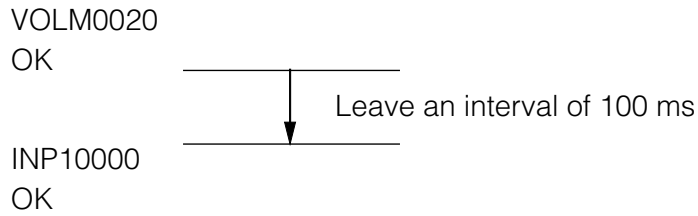

## PC Operation (Continued)

### RS-232C command table

#### <How to read the command table>

Command : **38** Command field

Direction : W When the "Parameter" is set in the parameter field (**38**), the command functions as described under "Control/Response Contents".  
 R The returned value indicated under "Reply" can be obtained by setting "????", "\_\_\_?" or "???" (repeater control) in the parameter field (**38**).

Parameter : **38** Parameter

Reply : Response Returned value

\*A circle indicates commands which can be used in power standby mode.

#### Power control, etc.

CONTROL ITEM		Command	Direction	Parameter	Reply	CONTROL/RESPONSE CONTENTS	*
POWER SETTING		POWR	W	0		Switches to standby.	○
				1		Returns from standby.	
		R		0		Standby state	
				1		Normal status	
				2		Power standby state ("Mode2" in "Power Management").	
CHANNEL DISPLAY	DISP	W	—		It displays channel display.		
VOLUME	VOLM	WR	0 - 60	0 - 60			
MUTE	MUTE	WR		0	0	OFF	
				1	1	ON	
SYNC CHECK	SYNC	W		0		It returns Yes/No.	
				1		It returns frequency.	
CAUSE OF LAST STANDBY	STCA	W	R	0		Content initialization	
				1		No standby operation (except remote control and monitor button operation) after initialization	
				2		Electrical standby due to some error condition (See cause of last error)	
				3		Invalid input has continued for a long time during PC display	
				4		It entered standby mode (PC mode: "Mode1" in "Power Management")	
				6		It entered standby mode by the command from RS-232C.	
CAUSE OF LAST ERROR	ERCA	WR		0		Content initialization	
				0		No detectable error has occurred	
				1		Invalid input has continued for a long time during PC display	
				2		Internal bus error	
				3		Abnormal temperature	
				4		Board connection error	
				5		Lamp error	
				7		Electrical system error	
				8		Error in communication with microcomputer	
POWER CONTROL	BRIGHTNESS	VLMP	WR	±8	±8	Brightness	
	POWER	PMNG	WR	0	0	Off	
LANGUAGE		LANG	WR	1		German	
				2		French	
				4		Spanish	
				13		Japanese	
				14		English	
RESET	RSET	W	4 digits			Input 4-digit PIN for parameter. It resets to factory preset value.	
	RSE+	W	4 digits			Input 4-digit PIN for parameter. It resets to factory preset value. For Repeater control	

## Input selection, etc.

INPUT SELECTION	INPUT1 SELECTION	INP1	W	0	Leaves input selection as is, and switches input to INPUT1
				1	Sets input selection for INPUT1 to "AV"
				2	Sets input selection for INPUT1 to "Y/C"
			R	1	Input selection for INPUT1 is "AV"
				2	Input selection for INPUT1 is "Y/C"
	INPUT2 SELECTION	INP2	W	0	Leaves input selection as is, and switches input to INPUT2. ERR if INPUT is set to output.
				1	Sets INPUT2 selection to "Input"
				9	Sets INPUT2 selection to "Output"
			R	1	INPUT2 selection is "Input"
				9	INPUT2 selection is "Output"
	INPUT3 SELECTION	INP3	W	0	Leaves input selection as is, and switches input to INPUT3
				1	Sets input selection for INPUT3 to "COMPONENT"
				2	Sets input selection for INPUT3 to "RGB"
			R	1	Input selection for INPUT3 is "COMPONENT"
2				Input selection for INPUT3 is "RGB"	
PC INPUT SELECTION	INPC	W	0	Leaves input selection as is, and switches input to PC	
			1	Sets input selection for PC to "Analog"	
			2	Sets input selection for PC to "Digital"	
	INPC	R	1	Input selection for PC is "Analog"	
			2	Input selection for PC is "Digital"	
INPUT SELECT	INPS	W	0	Toggle operation	
			1	Switches input to video terminal of INPUT1.	
			2	Switches input to S-video terminal of INPUT1.	
			4	Switches input to video terminal of INPUT2. (Returns ERR if set to output.)	
			5	Switches input to INPUT3.	
			6	Switches input to D-sub pin 15 terminal of PC	
			7	Switches input to DVI terminal of PC	
		R	1	Displays video signal from INPUT1	
			2	Displays S-terminal input video from INPUT1	
			4	Displays video from INPUT2	
			5	Displays INPUT3	
			6	Displays D-sub pin 15 terminal input video from PC	
			7	Displays DVI terminal input video from PC	
		ITGD	W	0	Toggle operation
		IAVD	W	1	Switches input to INPUT1.
				2	Switches input to INPUT2. (Return ERR if set to output.)
				3	Switches input to INPUT3.
IPCD	W	—	Switches input to PC.		
INPUT SOURCE DISPLAY	IMOD	R	1	INPUT1	
			2	INPUT2	
			3	INPUT3	
			5	PC	



# PC Operation (Continued)

Picture and audio adjustment, etc.

PICTURE ADJUSTMENT	CONTRAST	CONT	WR	0 - 40	0 - 40	
	BLACK LEVEL	BLVL	WR	±30	±30	
	COLOR	COLR	WR	±30	±30	
	TINT	TINT	WR	±30	±30	
	SHARPNESS	SHRP	WR	±10	±10	
	RED	REDG	WR	±30	±30	
	GREEN	GREN	WR	±30	±30	
	BLUE	BLUE	WR	±30	±30	
	C. M. S. (H)	CMHR	WR	±30	±30	Red
						Yellow
						Green
						Cyan
						Blue
						Magenta
	C. M. S. (S)	CMSR	WR	±30	±30	Red
						Yellow
						Green
						Cyan
						Blue
						Magenta
	C. M. S. (V)	CMVR	WR	±30	±30	Red
						Yellow
						Green
						Cyan
						Blue
						Magenta
	COLOR TEMP	CTMP	WR		0	Low
					1	Mid-Low
					2	Mid
					3	Mid-High
					4	High
	BLACK	BLAK	WR		0	Off
					1	High
					2	Low
	3D-Y/C	3DYC	WR		0	Standard
					1	Fast
					2	Slow
	MONOCHROME	MNCR	WR		0	Off
					1	On
	FILM MODE	FILM	WR		0	Off
					1	On
I/P SETTING	IPST	WR		0	Interlace	
				1	Progressive	
AUDIO ADJUSTMENT	TREBLE	TRBL	WR	±15	±15	
	BASS	BASS	WR	±15	±15	
	BALANCE	BLNC	WR	±30	±30	
COLOR SYSTEM	CLSY	W		0	AUTO	
				1	PAL	
				3	SECAM	
				4	NTSC358	
				5	NTSC443	
		R		0	AUTO	
				1	PAL	
				3	SECAM	
				4	NTSC358	
				5	NTSC443	

## Picture and audio adjustment, etc. (continued)

POSITION/FINE SYNC.	H-POSITION (AV)	HPOS	WR	±10	±10	Video/S-video INPUT3 (Component)			
	H-POSITION (PC)		WR	0 - 180	0 - 180	INPUT3 (RGB)/PC (Analog)			
	V-POSITION (AV)	VPOS	WR	±20	±20	Video/S-video INPUT3 (Component)			
	V-POSITION (PC)		WR	0 - 99	0 - 99	INPUT3 (RGB)/PC (Analog)			
	CLOCK	CLCK	WR	0 - 180	0 - 180	Returns ERR in case of a video signal			
PHASE	PHSE	WR	0 - 40	0 - 40	Returns ERR in case of a video signal				
AUTO SYNC.		ASNC	W	0		Abort (after execution)			
			1		Start				
		ASAE	WR	0		Setting cancel			
			1		Automatic execution when PC sync is input				
WIDE MODE	AV (Input1/Input2/Input3 (Component))	WIDE	WR	0	0	Toggle operation			
				1	1	Normal			
				2	2	Full 14:9			
				3	3	Zoom 14:9			
				4	4	Panorama			
				5	5	Cinema 14:9			
				6	6	Cinema 16:9			
				7	7	Full			
	8	8	Underscan						
	PC (Input3 (RGB)/PC)	WIDE	WR	0	0	Toggle operation			
				1	1	Normal			
				2	2	Full			
				3	3	Cinema			
				4	4	D by D			
				PICTURE FLIP	PFLP	WR	0	0	Normal
							1	1	Mirror
2							2	Upside Down	
3	3	Rotate							
ENLARGE	ENLARGE SETTING	EMAG	WR	0	0	Off			
				1	1	2×2			
				2	2	3×3			
	ENLARGED IMAGE POSITION	EPOS	WR	0	0	Enlarge Setting : Off			
				0	0	Enlarge Setting : 2x2) Upper left			
				1	1	Enlarge Setting : 2x2) Upper right			
				2	2	Enlarge Setting : 2x2) Lower left			
				3	3	Enlarge Setting : 2x2) Lower right			
				0	0	Enlarge Setting : 3x3) Upper left			
				1	1	Enlarge Setting : 3x3) Upper middle			
				2	2	Enlarge Setting : 3x3) Upper right			
				3	3	Enlarge Setting : 3x3) Middle left			
				4	4	Enlarge Setting : 3x3) Center			
				5	5	Enlarge Setting : 3x3) Middle right			
				6	6	Enlarge Setting : 3x3) Lower left			
				7	7	Enlarge Setting : 3x3) Lower middle			
8	8	Enlarge Setting : 3x3) Lower right							
DNR	DNR_	WR	0	0	Off				
			1	1	Low				
			2	2	High				
QUICK SHOOT	QSDV	WR	0	0	Off				
			1	1	On				
MONITOR SPEAKER OUTPUT	MOSP	WR	0	0	Fixed				
			1	1	Variable				
INPUT SIGNAL	PXCK	R		—	Returns current resolution in the form xxx,xxx.				
		PXSL	WR	0	0	V=400, 640x400			
	1		1	V=400, 720x400					
	0		0	V=480, 640x480					
	2		2	V=480, 848x480					
	3		3	V=480, 852x480					
	0		0	V=768, 1024x768					
	1		1	V=768, 1280x768					
	2	2	V=768, 1366x768						

# PC Operation (Continued)

## Other control options

ID NUMBER	ID NO. SETTING	IDST	W	0 - 255		It sets the monitor's ID number.		
			R		0 - 255	It returns the monitor's ID number.		
	ID NO. SETTING (ONCE)	IDSL	W	1 - 255		Sets a monitor ID number. This ID number is only effective for the command immediately after this command.		
				0		Clears the ID number if one has been designated.		
ID NO. SETTING (SUBSEQUENT)	IDLK	W	1 - 255		Sets a monitor ID number. This ID number is effective for the next and all subsequent commands after this command.	○		
			0		Clears the ID number if one has been designated.			
	ID CHECK	IDCK	W	—		Displays the selected ID number and the monitor's own ID number on the screen.		
CONTROL LOCK	MENU DISPLAY	LMNU	WR			Normal (Menu Display is available)		
				1	1	Menu Display is not available.		
	REMOTE CONTROL	LREM	WR			Normal (Operational)		
				1	1	Disabled		
	CONTROL BUTTONS	LBTN	WR			Normal (Operational)		
1				1	Disabled			
POWER	LPOW	WR			Normal (Operational)			
			1	1	Disabled			
RS232C	LCOM	WR			Normal (Operational)			
			1	1	Disabled			
PIN	SET PIN	PSET	W	4 digits		Sets PIN (Activates lock function)		
		PSE+	W	4 digits		Sets PIN: for repeater control		
	INPUT PIN	PINP	W	4 digits		Input of set PIN (Temporary unlock)		
		PIN+	W	4 digits		Input of set PIN: for repeater control		
	CLEAR PIN	PCLR	W	4 digits		Initializes PIN		
PCL+		W	4 digits		Initializes PIN: for repeater control			
POWER-ON METHOD, ETC.	MAX VOLUME	MVOL	WR	1 - 60	1 - 60	Maximum volume limit. Only displays volume in numbers when set to other than 60.		
				0	0	Off		
	FIX VOLUME	FVOL	WR					
				1	1	Fixes volume at a constant value		
	OSD SETTING	ODSP	WR					
				0	0	Normal		
				1	1	No OSD is displayed.		
	DISPLAY BOOT OPTION	FINP	WR					
				0	0	Normal		
				1	1	Starts with INPUT1 + [AV] input selection		
				2	2	Starts with INPUT1 + [Y/C] input selection		
				4	4	Starts with INPUT2. Returns ERR if INPUT2 selection is "Output"		
				5	5	Starts with INPUT3.		
6				6	Starts with PC + [Analog] input selection			
7				7	Starts with PC + [Digital] input selection			
11				11	Starts with INPUT1 + [AV] input selection, and remains fixed			
12	12	Starts with INPUT1 + [Y/C] input selection, and remains fixed						
14	14	Starts with INPUT2, and remains fixed. Returns ERR if INPUT2 selection is "Output".						
15	15	Starts with INPUT3, and remains fixed						
16	16	Starts with PC + [Analog] input selection, and remains fixed						
17	17	Starts with PC + [Digital] input selection, and remains fixed						
SOUND INPUT SELECT	SNDS	WR						
			0	0	Normal			
			1	1	Uses INPUT1 audio as fixed source			
			2	2	Uses INPUT2 audio as fixed source			
PANEL PROTECTION COVER	COVR	WR						
			0	0	Detached			
			1	1	Attached			

## Picture

<b>Contrast</b>	
Adjustable range	0 - 40
Default	30
+ direction	For more contrast
- direction	For less contrast
<b>Black Level</b>	
Adjustable range	-30 - +30
Default	0
+ direction	Brightens entire video signal
- direction	Darkens entire video signal
<b>Color (Video/S-video/COMPONENT)</b>	
Adjustable range	-30 - +30
Default	0
+ direction	For more color intensity
- direction	Decreases color intensity (Monochrome at "0")
<b>Tint (Video/S-video/COMPONENT)</b>	
Adjustable range	-30 - +30
Default	0
+ direction	Changes skin tone closer to green
- direction	Changes skin tone closer to magenta
<b>Sharpness (Video/S-video/COMPONENT)</b>	
Adjustable range	-10 - +10
Default	0
+ direction	For more sharpness
- direction	For less sharpness
<b>Advanced: C. M. S. (H)</b>	
Function	Six-color hue adjustments
Adjustable range	-30 - +30 (Red/Yellow/Green/Cyan/Blue/Magenta)
Default	0
+ direction	Move selected color hue clockwise
- direction	Move selected color hue counter-clockwise
<b>Advanced: C. M. S. (S)</b>	
Function	Six-color saturation adjustments
Adjustable range	-30 - +30 (Red/Yellow/Green/Cyan/Blue/Magenta)
Default	0
+ direction	Increases saturation of the selected color
- direction	Decreases saturation of the selected color
<b>Advanced: C. M. S. (V)</b>	
Function	Six-color image value adjustments
Adjustable range	-30 - +30 (Red/Yellow/Green/Cyan/Blue/Magenta)
Default	0
+ direction	Increases brightness of the selected image value
- direction	Decreases brightness of the selected image value

## Settings and Adjustments (Continued)

<b>Advanced: Color Temp (Video/S-video/INPUT 3 COMPONENT)</b>	
Adjustable range	High, Mid-High, Mid, Mid-Low, Low
Default	Mid
Upward	Entire image bluish tone (color temperature increases)
Downward	Entire image reddish tone (color temperature decreases)
<b>Advanced: Black (Video/S-video/INPUT 3 COMPONENT)</b>	
Adjustable range	Off, High, Low
Default	Low
Off	No Adjustment
High	For high detail in black portions
Low	For low detail in black portions
<b>Advanced: 3D-Y/C (Video)</b>	
Adjustable range	Standard, Fast, Slow
Default	Standard
Standard	Normal adjustment [Sets characteristics for 3-dimensional Y/C separation to standard setting.]
Fast	For movie image [Sets characteristics for 3-dimensional Y/C separation to settings appropriate for movies.]
Slow	For still image [Sets characteristics for 3-dimensional Y/C separation to settings appropriate for still pictures.]
Note:	Effective only when displaying video source with color system NTSC 3.58
<b>Advanced: Monochrome (Video/S-video/INPUT 3 COMPONENT)</b>	
Adjustable range	On/Off
Default	Off
On	Displays video in monochrome. ("Tint" cannot be adjusted. The setting automatically set to "Off" if "Color" is adjusted.)
Off	Normal color
<b>Advanced: Film mode (Video/S-video/INPUT 3 COMPONENT)</b>	
Adjustable range	On/Off
Default	On
On	Automatically detects that the source signal is a video image at 24 frames/sec (DVDs containing films etc.), and displays signal with high picture quality.
Off	Does not automatically detect sources at 24 frames/sec.
Note:	Effective only for interlaced video (480i/576i/1080i)
<b>Advanced: I/P Setting (Video/S-video/INPUT 3 COMPONENT)</b>	
Adjustable range	Interlace/Progressive
Default	Progressive
Interlace	Displays interlaced signal with 2-dimensional interpolation
Progressive	Displays interlaced signal with 3-dimensional interpolation
Note:	Effective only for Video, S-video and COMPONENT 480i/576i image
<b>Red (PC (analog)/INPUT3(RGB))</b>	
Adjustable range	-30 - +30
Default	0
+ direction	Brightens red component
- direction	Darkens red component

## Settings and Adjustments (Continued)

Green (PC (analog)/INPUT3(RGB))	
Adjustable range	-30 - +30
Default	0
+ direction	Brightens green component
- direction	Darkens green component
Blue (PC (analog)/INPUT3(RGB))	
Adjustable range	-30 - +30
Default	0
+ direction	Brightens blue component
- direction	Darkens blue component

## Audio

Treble	
Adjustable range	-15 - +15
Default	0
+ direction	For stronger treble
- direction	For weaker treble
Bass	
Adjustable range	-15 - +15
Default	0
+ direction	For stronger bass
- direction	For weaker bass
Balance	
Adjustable range	Left 30 - Right 30
Default	0 (center value)
Toward left	Decrease audio from the right speaker
Toward right	Decrease audio from the left speaker

## Power control

Brightness	
Function	Adjusts backlight brightness
Adjustable range	-8 - +8
Default	+8
+ direction	Increases backlight brightness
- direction	Decreases backlight brightness
Power Management	
Function	With this setting, the monitor automatically switches to (or returns from) the power standby mode, depending on the presence of a sync signal.
Adjustable range	Off/Mode1/Mode2
Default	Off
Off	No Power Management
Mode1	Detects sync signal of currently displayed video signal, and enters power standby mode if there is no sync signal for 8 minutes.
Mode2	Detects sync signal of currently displayed video signal, and enters power standby mode if there is no sync signal for 8 seconds. Restarts when sync signal is input again.

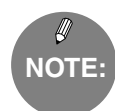

- The monitor may not work properly if the AC cord is unplugged and replugged when "Mode2" is selected in "Power Management". In this case simply press the STANDBY/ON button on the monitor or on the remote control.

## Settings and Adjustments (Continued)

### Setup

Control Lock: Lock Item (See page 58 for details.)	
Function	Lock/Unlock ("Menu Display", "Remote", "Buttons", "Power" and "RS-232C")
Adjustable range	Lock/Unlock ("Menu Display", "Remote", "Buttons", "Power" and "RS-232C")
Default	Unlock (all items)
Lock	The pertinent function is disabled when a PIN is set (see page 58).
Unlock	The pertinent function can be used, even if a PIN is set.
Control Lock: PIN (See page 58 for details.)	
Function	Sets 4-digit PIN After a PIN has been set, it becomes effective when the menu is closed. If a PIN is temporarily canceled (see page 58 for details), it remains canceled until the monitor enters standby mode or shuts down.
Control Lock: PIN Clear (See page 58 for details.)	
Function	Initializes set PIN. (Returns to state where no PIN has been input.)
Input Select	
Function	Selects video input terminal/type.
Adjustable range	INPUT1: AV / Y/C INPUT3: COMPONENT/RGB PC: Analog/Digital
Default	INPUT1: AV INPUT3: COMPONENT PC: Analog
Input Signal (INPUT3 (RGB) / (PC (analog)))	
Function	Manually selects input resolution.
Adjustable range	(Analog 400 vertical lines) 640 × 400/720 × 400 (Analog 480 vertical lines) 640 × 480/848 × 480/852 × 480 (Analog 768 vertical lines) 1024 × 768/1280 × 768/1366 × 768 (Digital 480 vertical lines) 640 × 480/480p
Default	(Analog 400 vertical lines) 640 × 400 (Analog 480 vertical lines) 640 × 480 (Analog 768 vertical lines) 1024 × 768 (Digital 480 vertical lines) 640 × 480
Auto Sync.: When Connected (INPUT3 (RGB) / (PC (analog)))	
Function	Automatically optimizes position, phase and clock when applicable video is input.
Adjustable range	Yes/No
Default	No
Note:	You can quickly achieve high-picture quality results by using a signal suited to the adjustment as the video signal used for adjustment. Conversely, performing adjustment with a signal unsuited for adjustment may cause adjustment to fail, or make it impossible to achieve good results even if it succeeds. Example of the ideal signal for use in adjustment: An image with full size and resolution, and a vertical stripe signal which inverts between black and white at each pixel. *Signals suitable for Auto Sync. <ul style="list-style-type: none"> <li>• Detailed still image with well-defined contrast</li> <li>• Image with high luminosity at edges</li> </ul> *Signals not suited for Auto Sync. <ul style="list-style-type: none"> <li>• Image with low contrast</li> <li>• Moving picture</li> <li>• Image with low luminosity at edges</li> </ul>

## Settings and Adjustments (Continued)

<b>Auto Sync.: Start Now</b>	
Function	If "Yes" is selected and the ENTER button is pressed when applicable video is input, the system automatically optimizes position, phase and clock using the video signal which is currently being input.
Adjustable range	Yes/No ("No" is always the default value)
<b>Position: H-pos. (Video/S-video/INPUT 3 COMPONENT)</b>	
Adjustable range	-10 - +10
Default	0
+ direction	Image shifts right.
- direction	Image shifts left.
<b>Position: V-pos. (Video/S-video/INPUT 3 COMPONENT)</b>	
Adjustable range	-20 - +20
Default	0
+ direction	Image shifts up.
- direction	Image shifts down.
<b>Fine Sync.: H-pos. (INPUT3 (RGB))/(PC (analog))</b>	
Adjustable range	0 - 180
Default	0
+ direction	Image shifts right.
- direction	Image shifts left.
Note:	No position adjustment is available when PC (digital) signal is received.
<b>Fine Sync.: V-pos. (INPUT3 (RGB) /(PC (analog))</b>	
Adjustable range	0 - 99
Default	(Varies depending on video frequency)
+ direction	Image shifts up.
- direction	Image shifts down.
Note:	No position adjustment is available when PC (digital) signal is received.
<b>Fine Sync.: Clock (INPUT3 (RGB) /(PC (analog))</b>	
Function	Adjusts frequency for sampling clock for applicable video. Adjust when there is flickering in the form of vertical stripes.
Adjustable range	0 - 180
Default	90
+ direction	Clock frequency increases
- direction	Clock frequency decreases
Note:	No clock frequency adjustment is available when PC (digital) signal is received.
<b>Fine Sync.: Phase (INPUT3 (RGB) /(PC (analog))</b>	
Function	Adjusts phase of sampling clock for applicable video. Useful when small characters appear with low contrast and/or there are flickers at corners.
Adjustable range	0 - 40
Default	20
+ direction	Advances clock phase
- direction	Delays clock phase
Note:	There is no clock phase adjustment for PC (digital) signals.



## Settings and Adjustments (Continued)

Picture Flip	
Adjustable range	Normal/Mirror/Upside Down/Rotate
Default	Normal
Normal	Normal image
Mirror	Mirror image
Upside Down	Upside down image
Rotate	Rotated image
Language	
Function	Selects display language setting.
Adjustable range	Japanese, English, German, French, Spanish
Default	English
INPUT2 Select	
Function	Selects INPUT2 terminal use.
Adjustable range	Input/Output
Default	Input
Input	Using as Input
Output	Using as Output
Note:	(This setting cannot be switched when INPUT2 is currently being displayed.)
ID No. Setting	
Function	Assigns ID numbers to monitors connected in a daisy chain (see page <b>37</b> ), using RS-232C cables.
Adjustable range	0 - 255
Default	0
Note:	The numbers 1 to 255 are available for ID numbers. (If "0" is set, the system regards this as the state where no ID number is set.) Although numbers up to 255 can be used for monitor IDs, the number of connectable monitors varies depending on the length of RS-232C cables and the installation environment. Use ◀▶ to move between digits, and ▲▼ to raise or lower digit values.
Enlarge: (see page <b>61</b> for details.)	
Function	Sets the image enlargement ratio, and the part of the original image to be enlarged.
Adjustable range	Off/2 × 2/3 × 3
Default	Off
↓ (After adjustment)	
Adjustable range (When set to "2 × 2")	1 - 4
Default (When set to "2 × 2")	1
Adjustable range (When set to "3 × 3")	1 - 9
Default (When set to "3 × 3")	1
Panel Protection Cover	
Function	Setting for panel protection cover. Be sure to set this item when using the cover.
Adjustable range	Attached/Detached
Default	Detached
Note:	Set to "Attached" when using the optional panel protection cover (commercially available in the future).

### Option

<b>Wide Mode (Video/S-video/INPUT 3 COMPONENT) (see page 63 for details.)</b>	
Adjustable range	Normal, Full 14:9, Zoom 14:9, Panorama, Cinema 14:9, Cinema 16:9, Full and Underscan
Default	Panorama
Note:	Available when receiving a 480i, 576i, 480p or 576p image.
<b>Wide Mode (INPUT 3 COMPONENT)</b>	
Adjustable range	Full, Underscan
Default	Full
Note:	Available when receiving 1080i or 720p image
<b>Wide Mode (INPUT3 (RGB)/PC (analog/digital)) (see page 62 for details.)</b>	
Adjustable range	Normal, Full, Cinema and Dot by Dot
Default	Normal
<b>Color System (Video/S-video)</b>	
Function	Selects color system for Video and S-video image. "Auto" (auto-detection of the color system) is the factory preset value. If normal discrimination cannot be achieved with the automatic setting, select the optimal color system manually.
Adjustable range	Auto, PAL, SECAM, NTSC 3.58, NTSC 4.43
Default	Auto
<b>DNR</b>	
Function	Reduces picture noise.
Adjustable range	Off/High/Low
Default	Low
Off	This feature is inactive.
High	Applies stronger noise reduction
Low	Applies weaker noise reduction
<b>Quick Shoot</b>	
Adjustable range	On/Off
Default	On
On	Improves the response of Liquid Crystal Panel when viewing fast-moving images.
<b>Monitor Speaker Output</b>	
Function	Selects whether to use built-in monitor speaker.
Adjustable range	On/Off
Default	Off
On	Outputs sound from built-in monitor speaker
Off	Does not output sound from built-in monitor speaker

## Settings and Adjustments (Continued)

---

### Detailed explanation

#### Control lock

##### Overview

This monitor is equipped with a control lock function to prevent third parties from changing the operating state. Locked functions cannot be used unless a PIN is input.

PINs can be freely set by the user.

The following types of operation can be locked.

- **Menu Display**  
When locked, MENU buttons on the remote control and monitor are disabled.
- **Remote Control**  
When enabled buttons on the remote control except STANDBY/ON are locked.
- **Monitor Buttons**  
When enabled monitor buttons except STANDBY/ON are locked.
- **Power**  
When locked, the STANDBY/ON button on the remote control and the monitor cannot perform switching from the operating state to the standby state. It can however, perform switching from the standby state to the operating state.
- **RS-232C**  
When enabled operation using RS-232C is locked.

#### Lock state and temporary unlock (Except for RS-232C)

When some functions are locked, you will be prompted to enter PIN if you attempt to use the function. If you enter the correct PIN, the locks on all locked functions are temporarily unlocked, so you can use the functions.

Functions which have been temporarily unlocked are locked again under the following conditions.

- |  |  |
|--|--|
| <ul style="list-style-type: none"><li>• The monitor entered standby mode.</li><li>• PIN was changed.</li></ul> | <ul style="list-style-type: none"><li>• Main POWER was turned off.</li><li>• Lock Items were modified.</li></ul> |
|--|--|

Even if functions are temporarily unlocked, the system will ask for a PIN if you try to enter "Control Lock" from the "Setup" menu. This is to prevent the PIN from being modified while it is temporarily unlocked.

#### Permanent unlocking (Except for RS-232C)

- 1) Select "Control Lock" from "Setup" in the menu screen.
- 2) Select "PIN Clear", then "Yes" and press ENTER.

#### Lock state and temporary unlock (RS-232C)

If RS-232C is locked and you sent an RS-232C command, LOCKED will come back as the returned value.

Only the following commands will work in this state.

- PINPxxxx ("xxxx" is the current PIN.)  
Temporarily unlocks the current lock.

Functions which have been temporarily unlocked are locked again under the following conditions.

- |  |  |
|--|--|
| <ul style="list-style-type: none"><li>• The monitor entered standby mode.</li><li>• PIN was changed.</li></ul> | <ul style="list-style-type: none"><li>• Main POWER was turned off.</li><li>• Lock Items were modified.</li></ul> |
|--|--|

- PIN+xxxx (“xxxx” is the current PIN.)  
This command temporarily releases current lock.  
“+” indicates repeater control for the PINP command. ( **42** **Repeater control**)
- PCLRxxxx (“xxxx” is the current PIN.)  
It reverts to the state where no PIN has been set.  
This is the same as “PIN Clear” under “Control Lock” on the “Setup” menu. (“Permanent unlocking”)
- PCL+xxxx (“xxxx” is the current PIN.)  
It reverts to the state where there is no PIN.  
“+” indicates repeater control for the PCLR command.

### Permanent Control lock deactivation (RS-232C)

When a single monitor is connected, use “PCLRxxxx” (“xxxx” is the current PIN.)

When multiple monitors are connected, use “PCLR+xxxx”.

If the “RS-232C” function is locked, the IDSL and IDLK commands cannot be used.

#### [Example: 1] Disabling remote control operations

- 1) From the menu screen, select “Control Lock” from “Setup”.
- 2) Go to “Lock Items”, then “Remote”, and select “Lock”.

**Note:** If you exit the menu at this point, the locking will not occur.

- 3) Go to PIN input, and enter a 4-digit PIN.
- 4) After PIN input, the set locks will become effective when you close the menu.

#### [Example: 2] Disabling remote control, monitor buttons and power operations

- 1) From the menu screen, select “Control Lock” from “Setup”.
- 2) Go to “Lock Items”, and set “Remote”, “Buttons” and “Power” to “Lock”.

**Note:** If you exit the menu at this point, the locking will not occur.

- 3) Go to PIN input screen and enter 4-digit PIN.
- 4) After PIN input, the set locks will become effective when you close the menu.

#### [Example: 3] Disabling menu display (RS-232C single connection)

**Note:** The returned value assumes that no ID has been set.

PCLRxxxx	←(“xxxx” is the current PIN. “xxxx” is not necessary if no PIN has been set.)
OK	
LMNU0001	←Locks menu display.
OK	
PSETxxxx	←(“xxxx” is new PIN.)
OK	

## Settings and Adjustments (Continued)

---

[Example: 4] Disabling remote control, monitor buttons and power operations (RS-232C daisy-chain connection)

Note: Values returned by monitors are omitted because they vary depending on the number of connected monitors.

PCL+xxxx	←("xxxx" is the current PIN. "xxxx" is not necessary if no PIN is set.)
LREM001+	←Locks remote control
LBTN001+	←Locks monitor buttons
LPOW001+	←Locks power operation
PSE+xxxx	←("xxxx" is new PIN.)

[Example: 5] Disabling remote control operation, operation using monitor buttons, and switching to the power standby state using those controls for a specific monitor (example: ID=2) in a chain of monitors connected via RS-232C.

Note: Response messages are omitted for convenience as the number of connected monitors varies.

IDLK0002	←Select monitor with ID=2
PCLRxxxx	←("xxxx" is the current PIN. "xxxx" is not necessary if no PIN is set.)
LREM0001	←Locks remote control
LBTN0001	←Locks monitor buttons
LPOW0001	←Locks power operation
PSETxxxx	←("xxxx" is new PIN.)
IDLK0000	←Exit "IDLK" command

### If you forget your PIN

If you forget the PIN which you yourself set, perform the following operation when the PIN input screen is displayed.



This allows you to temporarily unlock the function.

### ● Enlarge

- You can set up 4 or 9 monitors and integrate them into a single screen to display video. Each monitor displays an enlargement of 1/4 or 1/9 of the original image.

#### How to use the “Enlarge” feature

##### 4 screen monitor set-up

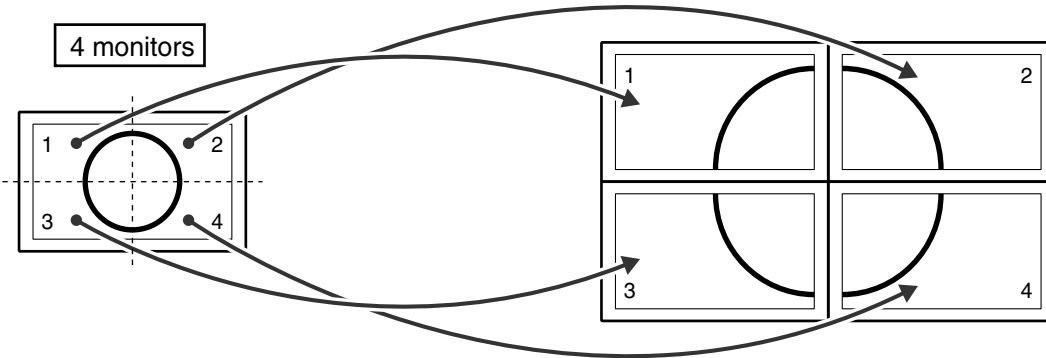

##### 9 screen monitor set-up

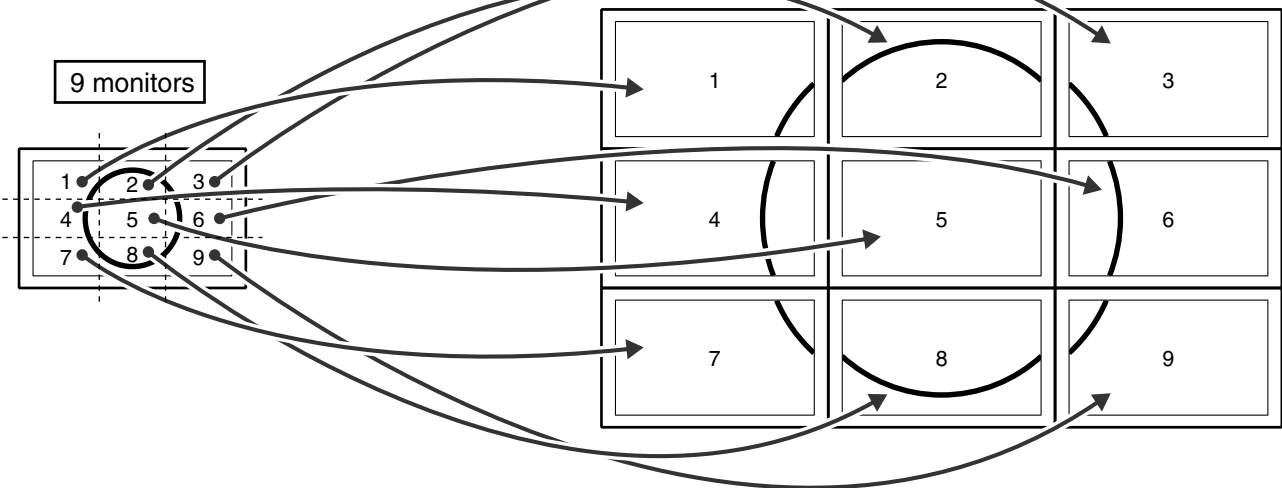

## Settings and Adjustments (Continued)

### ● Wide Mode (INPUT3 (RGB) /(PC (analog)))

■ In PC mode, you can select the following screen sizes to suit the input signal.

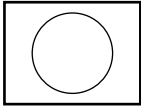
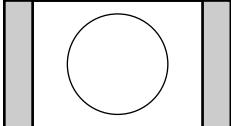
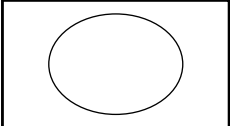
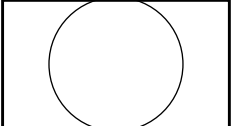
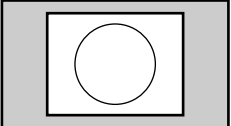
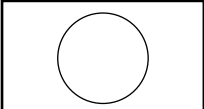
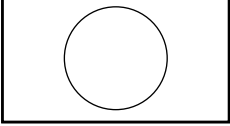
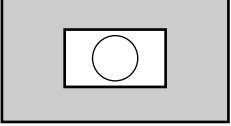
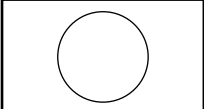
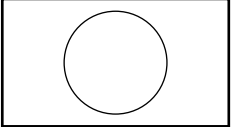
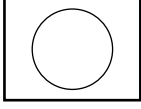
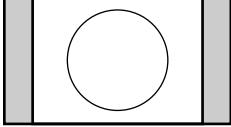
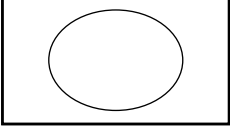
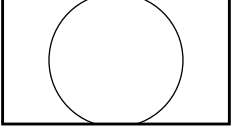
Input signal	Normal	Full	Cinema	Dot by Dot
<p>4:3 image</p>  <p>640 x 400, 720 x 400 640 x 480, 800 x 600 832 x 624, 1024 x 768</p>	 <p>Displays image so it fills the screen vertically, while maintaining the original aspect ratio.</p>	 <p>An image fully fills the screen.</p>	 <p>Keep the original aspect ratio in a full screen display. The top and bottom of the image is slightly cropped.</p>	 <p>Detects the resolution of the signal and displays an image with the same number of pixels on the screen.</p>
<p>16:9 image</p>  <p>848 x 480 852 x 480 1280 x 768</p>	/	 <p>An image fully fills the screen.</p>	/	 <p>Detects the resolution of the signal and displays an image with the same number of pixels on the screen.</p>
<p>16:9 image</p>  <p>1366 x 768</p>	/	/	/	 <p>Detects the resolution of the signal and displays an image with the same number of pixels on the screen.</p>
<p>5:4 image</p>  <p>1280 x 1024</p>	 <p>Displays image so it fills the screen vertically, while maintaining the original aspect ratio.</p>	 <p>An image fully fills the screen.</p>	 <p>Keep the original aspect ratio in a full screen display. The top and bottom of the image is slightly cropped.</p>	/

### What is “Dot by Dot”?

■ This function detects the resolution of the signal from a PC and displays an image with the same number of pixels, dot by dot. (See “Appendix 1: PC compatibility chart” on page 68).

### ● Wide Mode (Video, S-video, Input 3 COMPONENT)

The desired screen size can be selected to suit the input broadcast or software.

■ The following 8 screen sizes can be selected.

#### Normal

For 4:3 "Standard" pictures. A side bar appears on each side.

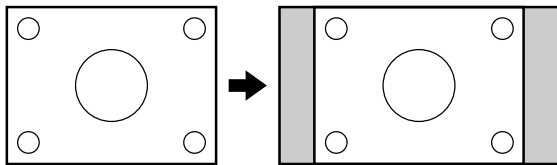

#### Full 14 : 9

For 14:9 squeeze pictures. A thin side bar appears on each side.

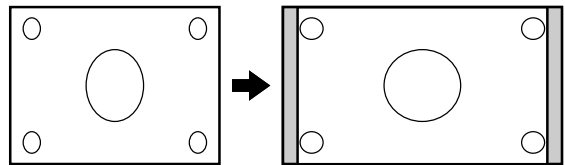

#### Zoom 14 : 9

For 14:9 letterbox pictures. An image vertically fills the screen.

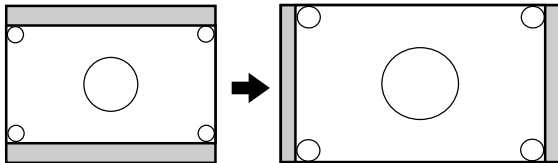

#### Panorama

In this mode the picture is progressively stretched toward each side of the screen.

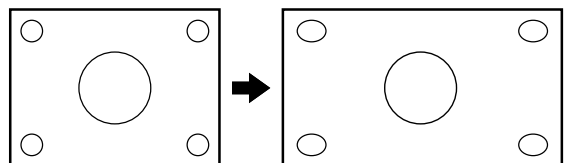

#### Cinema 14 : 9

Displays Cinescope 14:9 size movie software so it fills the entire screen.

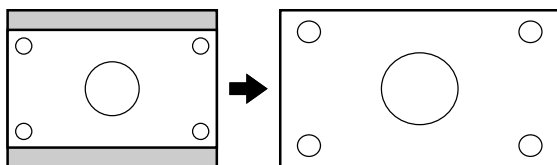

#### Cinema 16 : 9

For 16:9 letterbox pictures. An image fully fills the screen.

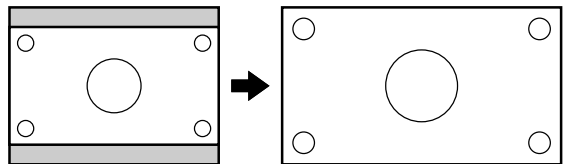

#### Full

Takes an image which has been compressed from 16:9 to 4:3, restores it to the original 16:9, and displays it so it fills the entire screen.

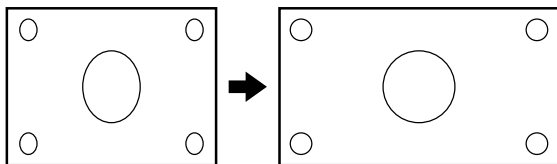

#### Underscan

Displays edge portion of the image which is normally cut off.

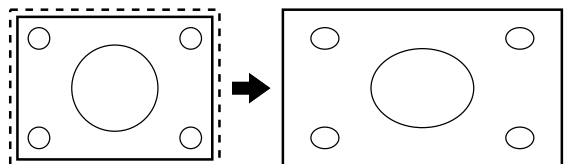

Special processing is performed for underscan, so switching takes more time than other screen sizes. This is not a malfunction.

"Underscan" employs special processing, so only some picture related adjustments can be used.



## Settings and Adjustments (Continued)

---

 NOTE:

- When set to “Enlarge” (i.e. with a “2 × 2” or “3 × 3” setting), the screen size is fixed in “Full” mode.
- When using the screen size selection function of this monitor, the appearance of the original video may change if you select a screen size with a different aspect ratio than the original image (i.e. TV broadcast or video input from an external device). Please consider this point when selecting the screen size.
- Using this monitor’s screen size switching function to compress or expand the screen for commercial or public viewing in establishments like cafes or hotels may infringe on the rights of creators, as protected by Copyright Law, so please be careful.
- When ordinary non-wide image (4:3) is viewed with the whole screen using the screen size switching function of this monitor, the edge of the image may be lost or appear distorted. If you wish to respect the creator’s intentions, set the screen size to “Normal”.
- When playing commercial software, parts of the image (like subtitles) image may be cropped. In this case select the optimal screen size using “Wide Mode” and adjust the vertical position (see “Position” on page 55). With some software, there may be noise or distortion at the edges or top of the screen. This is due to the characteristics of the software, and is not a malfunction.
- Depending on the original image size (i.e. CinemaScope size), black bands may remain at the top and bottom of the screen.





 Tips:

**When operating from Menu screen:**

- ① Press MENU and the MENU screen displays.
- ② Press ◀▶ to select “Option”.
- ③ Press ▲▼ to select “Wide Mode”, and then press ENTER.
- ④ Press ▲▼/◀▶ to select desired screen size.
- ⑤ Press MENU to turn off the MENU screen.

# Troubleshooting

Before calling for repair services, make sure following checks for possible remedies to the encountered symptoms.

Problem	Check item	Page
 <p>There is no picture or sound.</p>	<ul style="list-style-type: none"> <li>•Is the AC cord disconnected?</li> <li>•Is the Main POWER turned off or is the monitor in standby mode?</li> <li>•Make sure external devices are connected properly.</li> <li>•Make sure correct INPUT is selected.</li> <li>•Make sure the connected external device is operating (playing back).</li> </ul>	19 30 13 to 17 31 –
 <p>There is no picture.</p>	<ul style="list-style-type: none"> <li>•Has the correct terminal been selected with Input selection?</li> <li>•The signal may be incompatible.</li> <li>•Make sure sync signals (HD and VD) are connected correctly (INPUT3 RGB mode). When using INPUT3 (RGB) or PC (analog) input, a sync signal is necessary if the signal does not employ Sync on Green.</li> </ul>	54 – 15
<p>Remote control does not work.</p>	<ul style="list-style-type: none"> <li>•Are the batteries inserted with polarity (⊕, ⊖) aligned?</li> <li>•Are the batteries worn out?</li> <li>•Point the remote control toward the monitor's remote control sensor.</li> <li>•Is Control lock activated?</li> </ul>	11 54, 58
 <p>Sound from left and right speakers is reversed. Sound is heard from only one side.</p>	<ul style="list-style-type: none"> <li>•Are audio cables connected properly?</li> <li>•Make sure audio cables for external speakers are connected properly: left and right cables may be reversed or one of the two cables may not be connected.</li> <li>•The monitor speaker output is monaural.</li> </ul>	13 to 16 18 –
 <p>There is a picture but no sound</p>	<ul style="list-style-type: none"> <li>•Make sure the volume is not set to minimum.</li> <li>•S-video, COMPONENT-video and RGB terminals are for video only. Make sure audio cables are also connected.</li> <li>•Is the audio corresponding to the selected image being input?</li> <li>•Is audio output when monitor speaker output is set to "On"? If so, the problem is located subsequent to the external speaker output terminal. If not, the problem is in the input terminal or settings.</li> </ul>	31 13 to 16 13 to 16 57
 <p>Faint color or bad hue.</p>	<ul style="list-style-type: none"> <li>•Check "Color" and "Tint" adjustments.</li> <li>•When using INPUT3 input, make sure the connection sequence is correct.</li> </ul>	51 15
<p>Menu screen does not display. Monitor buttons do not work.</p>	<ul style="list-style-type: none"> <li>•Is Control lock activated?</li> </ul>	54, 58
<p>RS-232C command does not work.</p>	<ul style="list-style-type: none"> <li>•Are matching settings (for baud rate etc.) used on the PC side?</li> <li>•Is Control lock activated?</li> <li>•If monitors are chained, make sure connection between terminals are correct. (The side closer to the PC should be RS-232C INPUT, and the side further from the PC should be RS-232C OUTPUT.)</li> <li>•Make sure the command is correct.</li> <li>•Did you enter carriage return code (ODH) at the end of each command?</li> <li>•Is cross cable used for RS-232C connection? (Straight cable cannot transmit data).</li> <li>•Did you receive a response for the previous command? (Make sure OK or ERR message was returned.)</li> </ul>	37 54, 58 37 46 38 37 38

Settings and Adjustments

Troubleshooting and Specifications

## Troubleshooting (Continued)

---

### ■ Warning when temperature rises

#### Nature of warning:

- "Temperature" flashes at the lower right corner of the screen. The monitor automatically enters standby mode if temperature continues to rise.

#### Solution:

- If the monitor enters standby mode due to a rise in temperature, you can turn on the power on again in the usual way using the remote control or buttons on the monitor. However the monitor will enter standby mode again if the cause of the temperature rise is not eliminated.
- Check whether the monitor is placed at a location where a quick rise in temperature is likely. Internal temperature rises quickly if the vents on the back are blocked.
- Internal temperature rises quickly if dust accumulates inside the monitor or around the vents. Remove dust if possible. Ask your dealer about removing internal dust.

### Cracking sound

The monitor sometimes makes a cracking sound.

- You may hear cracking sound from the monitor. This happens when the cabinet slightly expands and contracts according to change in temperature. This does not affect the monitor's performance.

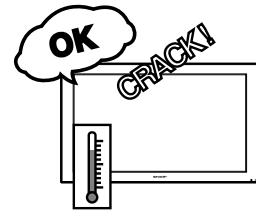

Product		Wide LCD Monitor
Model		LC-M3700/LC-M3710
LCD Panel	Screen size inch (mm)	37" (32 <sup>-17</sup> / <sub>64</sub> (819.6) (width) x 18 <sup>-9</sup> / <sub>64</sub> (460.8) (height), 37 <sup>-1</sup> / <sub>64</sub> (940.3) (diagonal))
	Drive	TFT (thin film transistor) Active Matrix
	Number of dots	3,147,264 dots (768 (height) x 1,366 (width) x 3)
Color system		NTSC (3.58/4.43MHz), PAL/PAL-60, SECAM
Speaker		φ 1 <sup>-31</sup> / <sub>32</sub> inch (5 cm), 1 piece
Audio amplifier		External speakers: 20 W (10 W + 10 W)      Built-in monitor speaker: 0.8 W
Terminals		
INPUT1		VIDEO in (BNC), S-video in, AUDIO (L/R) in
INPUT2(INPUT/OUTPUT)		VIDEO in/out (RCA), AUDIO (L/R) in/out
VIDEO OUTPUT		VIDEO out (BNC)
INPUT3 (Y/G, Cb/Pb/B, Cr/Pr/R, HD, VD)		COMPONENT video in/PC (ANALOG) in (BNC), AUDIO in (stereo jack, φ 3.5mm)
INPUT3/PC(ANALOG) OUTPUT		INPUT3/PC (ANALOG) OUTPUT (Mini D-Sub 15 pin)
PC(ANALOG)INPUT		PC (ANALOG) INPUT in (Mini D-Sub 15 pin), AUDIO in (stereo jack, φ 3.5 mm)
PC(DIGITAL)INPUT		PC (DIGITAL) INPUT in (DVI-D)
RS-232C INPUT terminal (9 pins), RS-232C OUTPUT terminal (9 pins), SPEAKER terminal (L/R), AC input terminal		
Power requirement		AC120V, 60Hz
Power consumption		181 W
Standby power consumption		0.8 W
Dimensions inch (mm)		37 <sup>-23</sup> / <sub>64</sub> x 3 <sup>-29</sup> / <sub>32</sub> x 22 <sup>-33</sup> / <sub>64</sub> (949 x 99.5 x 572)
Weight lbs. (kg)		41.9 (19) (without stand)
Operating temperature		0°C – +40°C
Operating humidity		20% – +80%

- As a part of policy of continuous improvement, SHARP reserves the right to make design and specification changes for product improvement without prior notice. The performance specification figures indicated are nominal values of production units. There may be some deviations from these values in individual units.
- The Liquid Crystal panel is a very high technology product with 3,147,264 thin film transistors, giving you fine picture details. Occasionally, a few non-active pixels may appear on the screen as a fixed point of blue, green or red. Please note that this does not affect the performance of your product.

## Optional accessories

- The listed optional accessories are available for the Wide LCD Monitor. Please purchase them at your nearest shop.

No.	Part name	Model name
1	Table stand	AN-37ST1
2	Wall-mount bracket	AN-37AG1

(As of June 2003)

- Additional optional accessories may be available in the near future. When purchasing, please read the newest catalogue for compatibility and check the availability.

### Mounting precautions

**Special techniques are required to mount this monitor, so be sure to rely on a specialist for mounting work. The customer should never perform any of this work himself or herself. Our company will bear no responsibility for accidents or injuries caused by improper mounting or handling.**

# Appendix 1: PC Compatibility Chart

## ● PC (analog) and INPUT3 (RGB) signal input compatibility chart

	Vertical frequency											
	43Hz <sup>(*)</sup>	50Hz	55Hz	56Hz	60Hz	65Hz	70Hz	72Hz	74.5Hz	75Hz	80Hz	85Hz
640 × 400		○	○		○	○	○			○	○	○
720 × 400		○	○		○	○	○			○	○	○
640 × 480		○	○		○	○	○	○		○	○	○
848 × 480		○	○		○	○	○	○		○	○	○
852 × 480		○	○		○	○	○	○		○	○	○
800 × 600		○	○	○	○	○	○	○		○	○	○
832 × 624									○			
1024 × 768	○	○	○	○	○		○		○		○	○
1280 × 768				○	○		○					
1280 × 1024					○							
1366 × 768					○							
540p					○							
1080i					○							
720p					○							

\* Interlaced

## ● PC (digital) signal input compatibility chart

640 × 480
480p
640 × 480
720 × 480
1440 × 480
848 × 480
852 × 480
800 × 600
832 × 624
1024 × 768
1280 × 768
1280 × 1024
1366 × 768
576p
640 × 576
720 × 576
1440 × 576
1080
720p

- Signal timing is confirmed primarily with VESA standard signals.
- Please note that it may be impossible to display signals with special timing, even if their resolution is listed in the Table.
- Please be aware that it may be impossible to output special resolutions with devices like an ordinary PC.

# Appendix 2: Dimensional Drawings

Unit: inch [mm]

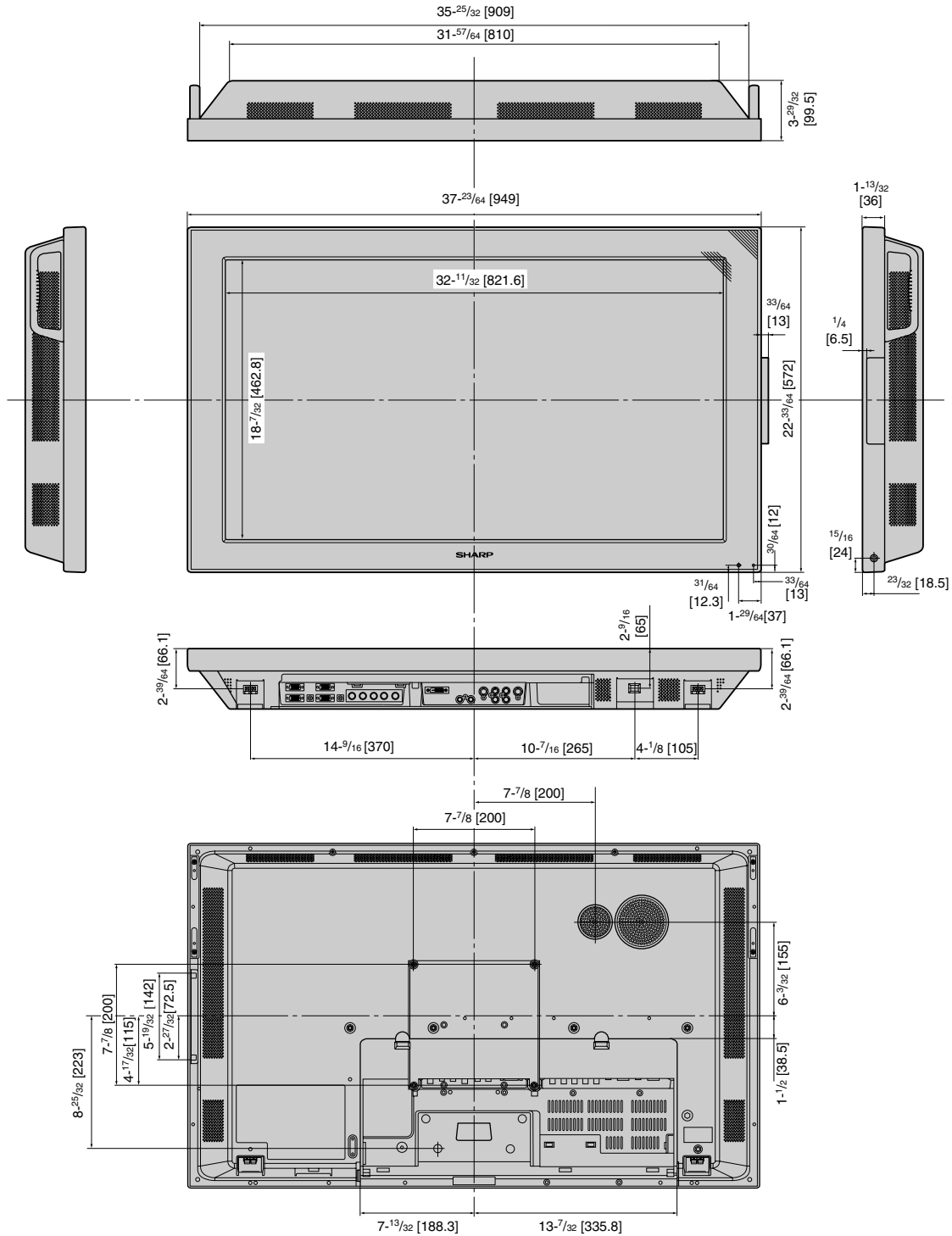

# Appendix 3: Menu Option Reference Chart

## Menu option reference chart: PC input mode

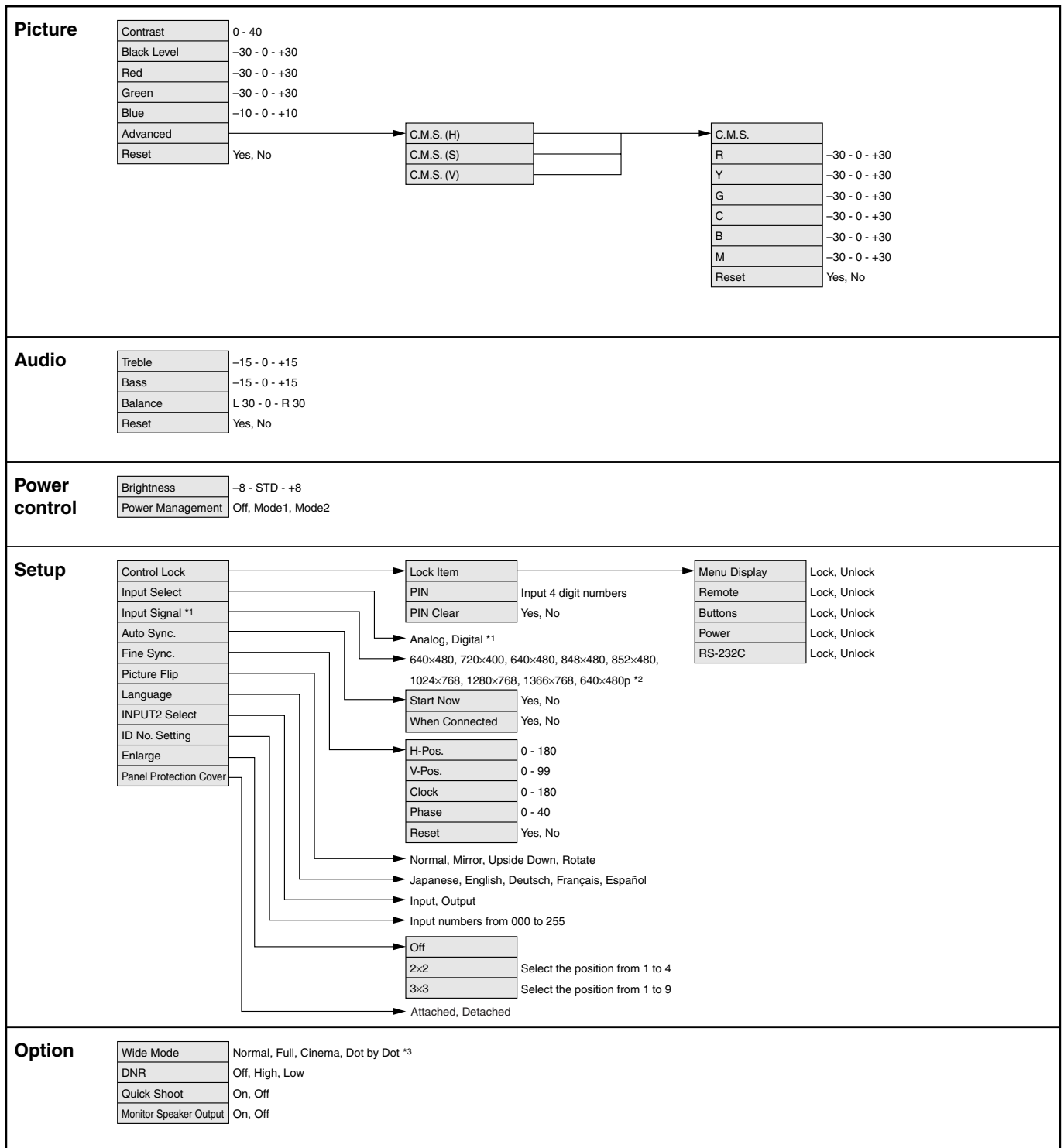

- \*1 May not be displayed for certain signal types.
- \*2 Items displayed may vary according to input signal types.
- \*3 Items displayed may vary according to input signal types.
- Depending on the conditions, certain menu items may be displayed in gray. These items cannot be selected.

## Menu option reference chart: AV input mode

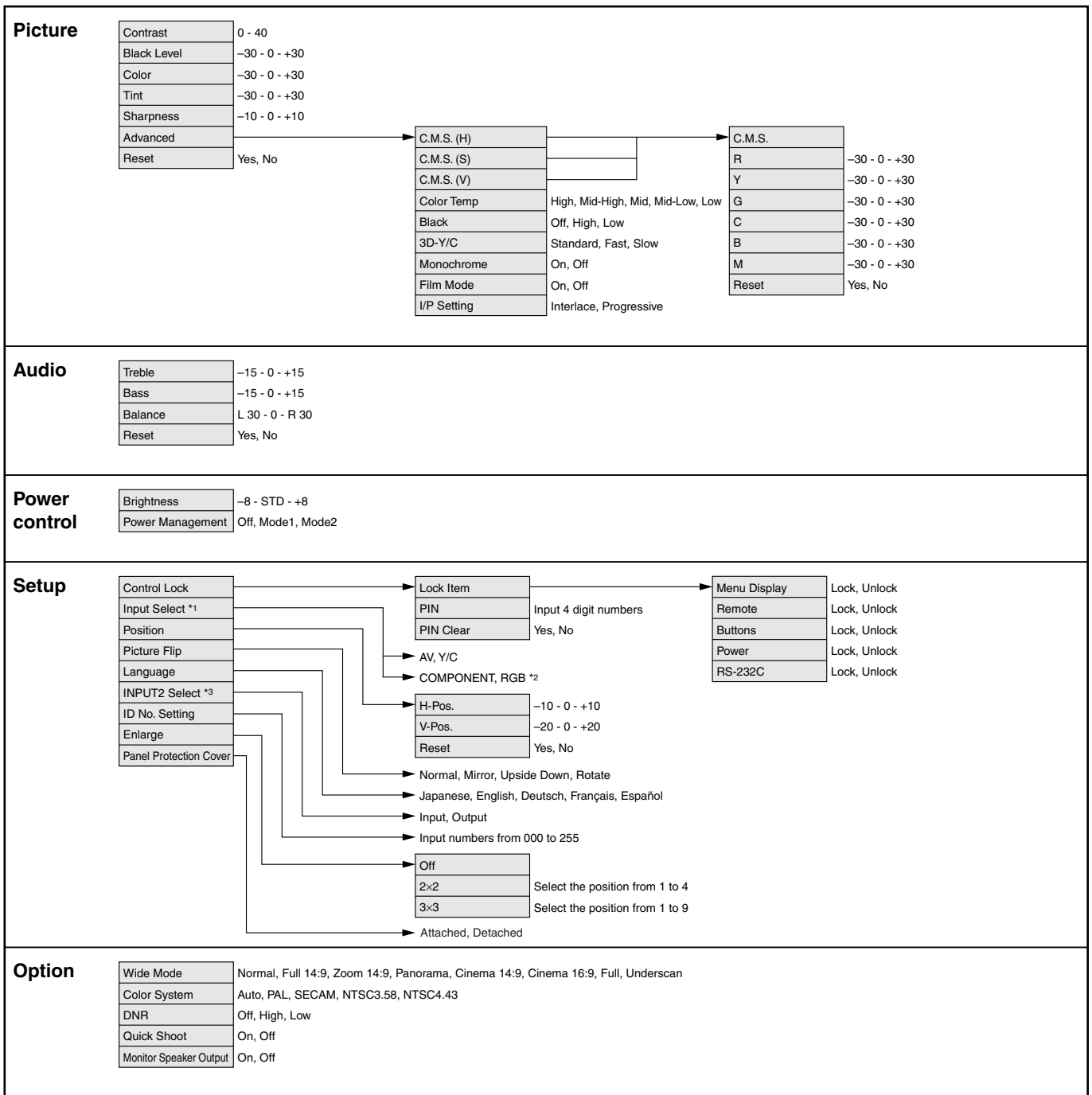

\*1 This item cannot be chosen if input other than "INPUT1" or "INPUT3" is selected.

\*2 Available only for "INPUT3"

\*3 Not available when "INPUT2" is selected.

• Depending on the conditions, certain menu items may be displayed in gray. These items cannot be selected.





## Free Manuals Download Website

<http://myh66.com>

<http://usermanuals.us>

<http://www.somanuals.com>

<http://www.4manuals.cc>

<http://www.manual-lib.com>

<http://www.404manual.com>

<http://www.luxmanual.com>

<http://aubethermostatmanual.com>

Golf course search by state

<http://golfingnear.com>

Email search by domain

<http://emailbydomain.com>

Auto manuals search

<http://auto.somanuals.com>

TV manuals search

<http://tv.somanuals.com>