



## Maintenance Guide

### Read This First

---

Trademarks.....	3
How to Read This Manual .....	4

### Paper and Other Media

---

Paper and Other Media Supported by This Printer.....	5
Paper Recommendations.....	10
Loading Paper.....	10
Storing Paper .....	10
Types of Paper and Other Media .....	10
Paper not supported by this printer.....	12
Print Area .....	13
Loading Paper .....	16
Loading Paper in Tray 1 and the optional paper feed unit .....	16
Loading Paper in the Bypass Tray .....	25
Loading Envelopes.....	32
Switching between Paper Trays.....	38

### Replacing Consumables and Maintenance Kit

---

Replacing the Toner Cartridge .....	39
Replacing the Maintenance Kit.....	44
Before Replacing.....	44
Replacing the Friction Pad .....	45
Replacing the Transfer Roller .....	47
Replacing the Paper Feed Rollers .....	50

Replacing the Fusing Unit .....	53
<b>Cleaning the Printer</b>	
<hr/>	
<b>Cautions to Take When Cleaning</b> .....	<b>60</b>
<b>Cleaning the Friction Pad</b> .....	<b>61</b>
<b>Cleaning the Paper Feed Roller</b> .....	<b>63</b>
<b>Cleaning the Registration Roller</b> .....	<b>67</b>
<b>Adjusting the Printer</b>	
<hr/>	
<b>Adjusting the Image Density</b> .....	<b>70</b>
<b>Adjusting Tray Registration</b> .....	<b>72</b>
<b>Troubleshooting</b>	
<hr/>	
<b>Error &amp; Status Messages on the Control Panel</b> .....	<b>75</b>
<b>Printer Does Not Print</b> .....	<b>83</b>
Checking the port connection.....	84
<b>Other Printing Problems</b> .....	<b>87</b>
<b>Additional Troubleshooting</b> .....	<b>91</b>
<b>Removing Misfed Paper</b>	
<hr/>	
<b>Removing Misfed Paper</b> .....	<b>93</b>
<b>When “Remove Misfeed Paper Tray” Appears</b> .....	<b>94</b>
<b>When “Remove Misfeed Internal Path” Appears</b> .....	<b>96</b>
<b>When “Remove Misfeed Paper Exit Cover” Appears</b> .....	<b>99</b>
<b>When “Remove Misfeed Duplex Unit” Appears</b> .....	<b>104</b>
<b>Appendix</b>	
<hr/>	
<b>Moving and Transporting the Printer</b> .....	<b>108</b>
Moving the Printer .....	108
<b>Consumables</b> .....	<b>110</b>
Toner Cartridge .....	110
Maintenance Kit .....	110
<b>Specifications</b> .....	<b>112</b>
Mainframe .....	112
Options.....	115

# Trademarks

Microsoft, Windows and Windows NT are registered trademarks of Microsoft Corporation in the United States and/or other countries.

IPS-PRINT Printer Language Emulation Copyright© 1999-2000 Oak Technology, Inc., All rights reserved.

Bluetooth® is a registered trademark of Bluetooth-SIG Inc. worldwide.

Other product names used herein are for identification purposes only and might be trademarks of their respective companies. We disclaim any and all rights to those marks.

The proper names of the Windows operating systems are as follows:

- Microsoft® Windows® 95 operating system
- Microsoft® Windows® 98 operating system
- Microsoft® Windows® Millennium Edition (Windows Me)
- The product names of Windows® 2000 are as follows:  
Microsoft® Windows® 2000 Advanced Server  
Microsoft® Windows® 2000 Server  
Microsoft® Windows® 2000 Professional
- The product names of Windows® XP are as follows:  
Microsoft® Windows® XP Professional  
Microsoft® Windows® XP Home Edition
- The product names of Windows Server™ 2003 are as follows:  
Microsoft® Windows Server™ 2003 Standard Edition  
Microsoft® Windows Server™ 2003 Enterprise Edition  
Microsoft® Windows Server™ 2003 Web Edition
- The product names of Windows NT® 4.0 are as follows:  
Microsoft® Windows NT® Server 4.0  
Microsoft® Windows NT® Workstation 4.0

# How to Read This Manual

The following set of symbols is used in this manual.

## **WARNING**

This symbol indicates a potentially hazardous situation that might result in death or serious injury when you misuse the machine without following the instructions under this symbol. Be sure to read the instructions, all of which are described in the Safety Information section.

## **CAUTION**

This symbol indicates a potentially hazardous situation that might result in minor or moderate injury or property damage that does not involve personal injury when you misuse the machine without following the instructions under this symbol. Be sure to read the instructions, all of which are described in the Safety Information section.

\* The statements above are notes for your safety.

### Important

If this instruction is not followed, paper might be misfed, originals might be damaged, or data might be lost. Be sure to read this.

### Preparation

This symbol indicates information or preparations required prior to operating.

### Note

This symbol indicates precautions for operation, or actions to take after abnormal operation.

### Limitation

This symbol indicates numerical limits, functions that cannot be used together, or conditions in which a particular function cannot be used.

### Reference

This symbol indicates a reference.

[ ]

Keys that appear on the machine's display.

Keys and buttons that appear on the computer's display.

[ ]

Keys built into the machine's control panel.



Keys on the computer's keyboard.

# Paper and Other Media Supported by This Printer

This section describes the paper size, feed direction, and the maximum amount of paper that can be loaded into each paper tray in this printer.











 Note

















- The following symbols and terminology are used to represent the feed direction.





In this manual	On the display	Paper feed direction
 ↑(Feed direction)	A4 (297 x 210) 8 1/2 x 11	Short-edge feed direction
 ↑(Feed direction)	A5 (210 x 148) 8 1/2 x 5 1/2	Long-edge feed direction

- Be careful of the paper feed direction. The direction is determined for each paper size.

## ❖ Input Paper Sizes (Metric version)

	Feed direction	Size (mm)	Bypass Tray	Paper Tray (Tray1)	Paper Feed Unit (Tray2/3)	Envelope Feeder Unit
A3		297 × 420	☆	⊙	⊙	×
B4 JIS		257 × 364	☆	○	○	×
A4		210 × 297	☆	⊙	⊙	×
		297 × 210	☆	⊙	⊙	×
B5 JIS		182 × 257	☆	○	○	×
		257 × 182	☆	○	○	×
A5		148 × 210	☆	×	×	×
		210 × 148	☆	⊙	×	×
A6		105 × 148	☆	×	×	×
11 × 17		279 × 432	☆	○	⊙	×
Legal (LG, 8 <sup>1</sup> / <sub>2</sub> × 14)		216 × 356	☆	○	⊙	×

	Feed direction	Size (mm)	Bypass Tray	Paper Tray (Tray1)	Paper Feed Unit (Tray2/3)	Envelope Feeder Unit
Letter (LT, 8 <sup>1</sup> / <sub>2</sub> × 11)		216 × 279	☆	⊙	⊙	×
		279 × 216	☆	⊙	⊙	×
5 <sup>1</sup> / <sub>2</sub> × 8 <sup>1</sup> / <sub>2</sub>		140 × 216	☆	×	×	×
Executive (Exec., 7 <sup>1</sup> / <sub>4</sub> × 10 <sup>1</sup> / <sub>2</sub> )		184 × 276	☆	×	○	×
		276 × 184	☆	○	○	×
Folio (8 <sup>1</sup> / <sub>4</sub> × 13)		210 × 330	☆	○	○	×
Foolscap (F4, 8 <sup>1</sup> / <sub>2</sub> × 13)		216 × 330	☆	○	○	×
F/GL (8 × 13)		203 × 330	☆	○	○	×
Com#10 Env (4 <sup>1</sup> / <sub>8</sub> × 9 <sup>1</sup> / <sub>2</sub> )		104.8 × 241.3	☆	×	×	☆
C5 Env (6.38 × 9.02)		162 × 229	☆	×	×	☆
C6 Env (4.49 × 6.38)		114 × 162	☆	×	×	☆
DL Env (4.33 × 8.66)		110 × 220	☆	×	×	☆
Monarch Env (3 <sup>7</sup> / <sub>8</sub> × 7 <sup>1</sup> / <sub>2</sub> )		98.4 × 190.5	☆	×	×	☆
Custom Size	-	-	★	×	★	×
8K (10 <sup>1</sup> / <sub>2</sub> × 15.35)		267 × 390	☆	○	○	×
16K (7.68 × 10 <sup>1</sup> / <sub>2</sub> )		195 × 267	☆	○	○	×
		267 × 195	☆	○	○	×

-  The size is supported and indicated on the tray dial. Be sure to set the paper size dial to match the actual paper size loaded in the tray.
-  The size is supported but not indicated on the tray dial. You should set the tray dial to “✖”, and select the paper size with the control panel.
-  The size is supported but the paper size should be set with the control panel. There is no dial on the tray.  
See [p.25 “Loading Paper in the Bypass Tray”](#)  
See [p.32 “Loading Envelopes”](#)
- 

















The size is supported, but it should be set as a custom size using the control panel.











The supported size may differ depending on the printer language you use. Set as a custom size setting using the control panel.





The following sizes are supported:

- Bypass Tray: approximately 90 - 305 mm in width, and 148 - 432 mm in length.
- Paper Feed Unit (Tray 2/3): approximately 182 - 297 mm in width, and 160 - 432 mm in length.
- ×  
The size is not supported.

❖ **Input Paper Sizes (Inch version)**

	Feed direction	Size (inch)	Bypass Tray	Paper Tray (Tray1)	Paper Feed Unit (Tray2/3)	Envelope Feeder Unit
11 × 17		11 × 17	☆	⊙	⊙	×
Legal (LG)		8½ × 14	☆	⊙	⊙	×
Letter (LT)		8½ × 11	☆	⊙	⊙	×
		11 × 8½	☆	⊙	⊙	×
5½ × 8½		5½ × 8½	☆	×	×	×
Executive (Exec.)		7¼ × 10½	☆	×	○	×
		10½ × 7¼	☆	○	○	×
A3		11.26 × 16.54	☆	○	⊙	×
B4 JIS		10.12 × 14.33	☆	○	○	×
A4		8.26 × 5.83	☆	○	⊙	×
		5.83 × 8.26	☆	⊙	⊙	×
B5 JIS		7.17 × 10.12	☆	○	○	×
		10.12 × 7.17	☆	○	○	×
A5		5.83 × 8.26	☆	×	×	×
		8.26 × 5.83	☆	○	×	×
A6		4.13 × 5.63	☆	×	×	×

	Feed direction	Size (inch)	Bypass Tray	Paper Tray (Tray1)	Paper Feed Unit (Tray2/3)	Envelope Feeder Unit
Folio		8 <sup>1</sup> / <sub>4</sub> × 13	☆	○	○	×
Foolscap F4		8 <sup>1</sup> / <sub>2</sub> × 13	☆	⊙	○	×
F/GL		8 × 13	☆	○	○	×
Com#10 Env		4 <sup>1</sup> / <sub>8</sub> × 9 <sup>1</sup> / <sub>2</sub>	☆	×	×	☆
C5 Env		6.38 × 9.02	☆	×	×	☆
C6 Env		4.49 × 6.38	☆	×	×	☆
DL Env		4.33 × 8.66	☆	×	×	☆
Monarch Env		3 <sup>7</sup> / <sub>8</sub> × 7 <sup>1</sup> / <sub>2</sub>	☆	×	×	☆
Custom Size	-	-	★	×	★	×
8K		10 <sup>1</sup> / <sub>2</sub> × 15.35	☆	○	○	×
16K		7.68 × 10 <sup>1</sup> / <sub>2</sub>	☆	○	○	×
		10 <sup>1</sup> / <sub>2</sub> × 7.68	☆	○	○	×

-  The size is supported and indicated on the tray dial. Be sure to set the paper size dial to match the actual paper size loaded in the tray.
-  The size is supported but not indicated on the tray dial. You should set the tray dial to “✱”, and select the paper size with the control panel.
-  The size is supported but the paper size should be set with the control panel. There is no dial on the tray.  
See [p.25 “Loading Paper in the Bypass Tray”](#)  
See [p.32 “Loading Envelopes”](#)
-  The size is supported, but it should be set as a custom size using the control panel.  
The supported size may differ depending on the printer language you use. Set as a custom size setting using the control panel.  
The following sizes are supported:
  - Bypass Tray: approximately 3.54 - 12.01 inches in width, and 5.83 - 17.01 inches in length.



- Paper Feed Unit (Tray 2/3): approximately 7.17 - 11.69 inches in width, and 6.3 - 17.01 inches in length.
- ×  
The size is not supported.

#### ❖ Paper weight and number of sheets to be set



















	Supported paper weight	Maximum number of sheets (plain paper)
Tray 1	60 - 105 g/m <sup>2</sup> (16 - 28 lb.)	500 (80 g/m <sup>2</sup> , 20 lb.)
Bypass Tray	52 - 162 g/m <sup>2</sup> (14 - 43 lb.)	100 (80 g/m <sup>2</sup> , 20 lb.) For other kind of papers, see <a href="#">p.25 "Loading Paper in the Bypass Tray"</a> .
Paper Feed Unit (Tray 2, Tray 3)	60 - 105 g/m <sup>2</sup> (16 - 28 lb.)	500 (80 g/m <sup>2</sup> , 20 lb.)
Envelope Feeder Type 2600	See <a href="#">p.32 "Loading Envelopes"</a> .	

#### ↓ Note

- Check that the top of the stack is not higher than the limit mark inside the tray.
- The envelope feeder unit requires the installation of the optional paper feed unit.

#### ❖ Paper size not supported by both side printing

The following paper sizes cannot be printed on both sides:

- Metric version: A5 , A6 , 5<sup>1</sup>/<sub>2</sub> × 8<sup>1</sup>/<sub>2</sub> , Executive (184 × 246) , Com#10 Env (104.8 × 241.3) , C5 Env (162 × 229) , C6 Env (114 × 162) , DL Env (110 × 220) , Monarch Env (98.4 × 190.5) .
- Custom Size supported by approximately 182 to 297 mm in width, and approximately 148 to 432 mm in length.
- Inch version: A5 , A6 , 5<sup>1</sup>/<sub>2</sub> × 8<sup>1</sup>/<sub>2</sub> , Executive (7<sup>1</sup>/<sub>4</sub> × 10<sup>1</sup>/<sub>2</sub>) , Com#10 Env (4<sup>1</sup>/<sub>8</sub> × 9<sup>1</sup>/<sub>2</sub>) , C5 Env (6.38 × 9.02) , C6 Env (4.49 × 6.38) , DL Env (4.33 × 8.66) , Monarch Env (3<sup>7</sup>/<sub>8</sub> × 7<sup>1</sup>/<sub>2</sub>) .
- Custom Size supported by approximately 7.18 - 11.68 inches in width, and approximately 5.83 - 17.00 inches in length.

# Paper Recommendations

## Loading Paper

### ★ Important

- Do not use ink-jet printer paper because it may stick to the fusing unit and cause a paper misfeed.
- When printing on OHP transparencies that have a print side, load them with the print side over on the bypass tray. Not taking this precaution may cause them to stick to the fusing unit and cause misfeeds.
- Set the paper as described below.
  - Tray 1: Print side facing down
  - Bypass Tray: Print side facing up
  - Paper Feed Unit (Tray 2, Tray 3): Print side facing down
- Print quality cannot be guaranteed if paper other than the ones recommended is used. For more information about recommended paper, contact your sales or service representative.
- Do not use paper that has already been printed onto by other printers.

## Storing Paper

- Paper should always be stored properly. Improperly stored paper might result in poor print quality, paper misfeeds, or printer damage. Recommendations are as follows:
  - Avoid storing paper in humid areas.
  - Avoid exposing paper to direct sunlight.
  - Store on a flat surface.
- Keep paper in the package in which the paper came.

## Types of Paper and Other Media

### Plain Paper

Paper thickness	60 - 105 g/m <sup>2</sup> (16 - 28 lb.)
Printer setup	<p>Press <b>[Paper Input]</b> menu, <b>[Paper Type]</b>, and then <b>[Plain Paper]</b>.</p> <p> <b>Note</b></p> <p><input type="checkbox"/> The paper type selected using the printer driver overrides that selected using the control panel.</p>
Printer driver setup	Click <b>[Plain]</b> or <b>[Plain &amp; Recycled]</b> in the <b>[Type:]</b> list.

Enabled paper feeding tray	Any input tray can be used.
Number of sheets that can be set	<ul style="list-style-type: none"> <li>• Tray 1: 500</li> <li>• Tray 2, Tray 3 (Paper Feed Unit Type 610): 500</li> <li>• Bypass Tray: 100</li> </ul> <p> <b>Note</b></p> <p><input type="checkbox"/> Make sure paper is not stacked higher than the upper limit mark (▼) inside the tray. Make sure paper is not stacked higher than the paper guides inside the bypass tray.</p>
Both-side printing	Possible
Additional cautions	When printing on 91 - 105 g/m <sup>2</sup> paper, print speed is slightly slower to when printing on paper of 60 - 91 g/m <sup>2</sup> .

### Thick Paper



Paper thickness	105 - 162 g/m <sup>2</sup> (28 - 43 lb.)
Printer setup	<p>Press <b>[Paper Input]</b> menu, <b>[Paper Type]</b> and then <b>[Thick Paper]</b> on the control panel.</p> <p> <b>Note</b></p> <p><input type="checkbox"/> The paper type selected using the printer driver overrides that selected using the control panel.</p>
Printer driver setup	Click <b>[Thick]</b> in the <b>[Type:]</b> list.
Enabled paper feeding tray	Bypass Tray
Number of sheets that can be set	Make sure paper is not stacked higher than the upper limit mark (▼) inside the tray. Make sure paper is not stacked higher than the paper guides inside the bypass tray.
Both-side printing	Not possible
Additional cautions	Print speed is slightly slower than when using plain paper.

### OHP transparencies

Printer setup	<p>Press <b>[Paper Input]</b> menu, <b>[Paper Type]</b>, and then <b>[Transparency]</b> on the control panel.</p> <p> <b>Note</b></p> <p><input type="checkbox"/> The paper type selected using the printer driver overrides that selected using the control panel.</p>
Printer driver setup	Click <b>[Transparency]</b> in the <b>[Type:]</b> list.
Enabled paper feeding tray	Bypass tray
Number of sheets that can be set	Load only one OHP transparency at the same time onto the bypass tray.
Both-sided printing	Not possible

Additional cautions	<ul style="list-style-type: none"> <li>• Print speed for OHP transparencies is slower than for plain paper.</li> <li>• Due to switching modes, the machine will be on standby for thirty or forty seconds after the job was received.</li> </ul>
---------------------	--

## Envelopes

Printer setup	<p>Press <b>[Paper Input]</b> menu, <b>[Paper Type]</b>, and then press <b>[Thick Paper]</b> on the control panel.</p> <p> Note</p> <p><input type="checkbox"/> The paper type selected using the printer driver overrides that selected using the control panel.</p>
Printer driver setup	Click <b>[Thick]</b> in the <b>[Type:]</b> list.
Enabled paper feeding tray	<p>Any input tray can be used.</p> <p> Note</p> <p><input type="checkbox"/> Make sure paper is not stacked higher than the upper limit mark (▼) inside the tray. Make sure paper is not stacked higher than the paper guides inside the bypass tray.</p>
Both-sided printing	Not possible
Additional cautions	<ul style="list-style-type: none"> <li>• Check the print side is facing up.</li> <li>• Check there is no air in the envelopes before loading.</li> <li>• For better print quality, we recommend the right, left, top, and bottom print margins to be at least 20 mm (0.8") each.</li> <li>• Load only one size and type of envelope at a time.</li> <li>• Before loading envelopes, flatten their leading edges (the edge going into the printer) by running a pencil or ruler across them.</li> <li>• Some kinds of envelope might cause misfeeds, wrinkles or print poorly.</li> <li>• Print quality on envelopes may be uneven if parts of an envelope have differing thicknesses. Print one or two envelopes to check print quality.</li> </ul>

## Paper not supported by this printer

Avoid using the following paper as they are not supported by this printer.

- Paper meant for an ink-jet printer
- Bent, folded, or creased paper
- Curled or twisted paper
- Torn paper
- Wrinkled paper
- Damp paper
- Paper that is dry enough to emit static electricity

- Paper that has already been printed onto, except a preprinted letterhead  
Malfunctions are especially likely when using paper printed on by other than a laser printer (e.g. monochrome and color copiers, ink-jet printers, etc.)
- Special paper, such as thermal paper, aluminum foil, carbon paper and conductive paper
- Paper whose weight is heavier or lighter than the limitation
- Paper with windows, holes, perforations, cutouts, or embossing
- Adhesive label paper on which glue or base paper is exposed
- Paper with clips or staples
- Envelopes in the following conditions:
  - damp
  - excessively curled or twisted
  - stuck together
  - damaged in any way
  - with stamps attached
  - with windows, holes, perforations, cutouts or embossing
  - with metal clasps, string ties or metal folding bars
  - designed to be interlocked
  - with nicked edges or bent corners
  - with rough, wrinkled or laid finishes
  - with any exposed adhesive, when the flap is in the sealed or closed position

---

## **Print Area**

---

The following shows the print area for this printer. Be sure to set the print margins correctly by the application.

❖ Paper

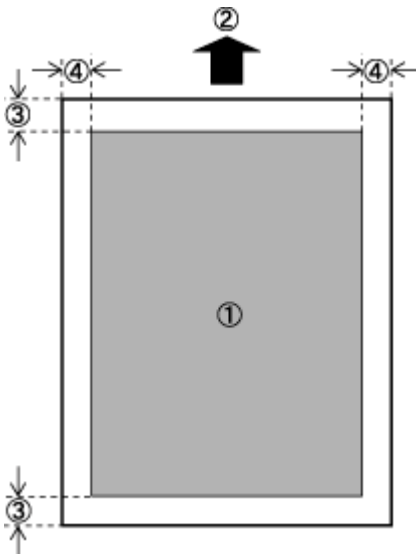

- ① Print area
- ② Feed direction
- ③ Approx. 4.2 mm (0.18 inches)
- ④ Approx. 4.2 mm (0.18 inches)

↓ Note

- The print area may vary depending on the paper size, printer language and printer driver settings.

❖ Envelope

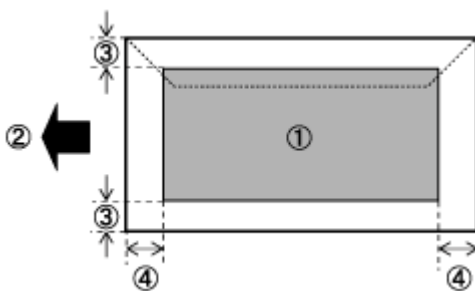

- ① Print area
- ② Feed direction
- ③ Approx. 4.2 mm (0.18 inches)
- ④ Approx. 4.2 mm (0.18 inches)



- The print area may vary depending on the paper size, printer language and printer driver settings.

# Loading Paper

This describes how to load paper into the paper tray and bypass tray.

## **⚠ CAUTION**

- *Do not pull out the paper tray forcefully. If you do, the tray might fall and cause an injury.*

## Loading Paper in Tray 1 and the optional paper feed unit

The following example explains loading procedure for the standard paper tray (Tray 1). The same procedure can be used for the optional paper feed unit.

### **★ Important**

- Make sure paper is not stacked above the limit mark inside the tray. Misfeeds might occur.
- Do not put different types of paper in a single paper tray.
- Up to 500 sheets of paper can be loaded in the paper feed unit. This means a maximum of 1,600 sheets can be simultaneously loaded when two additional paper feed units are installed.

**1** Lift the paper tray slightly, and then pull it out until it stops.

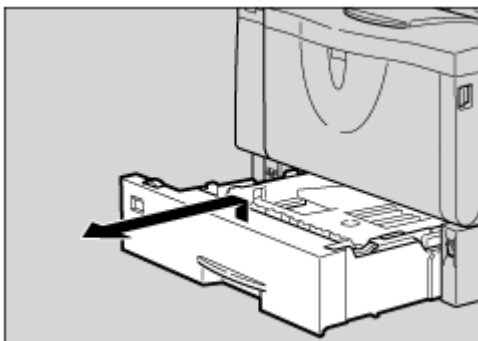

ZK03Y1-03B

**2** Lift the front side of the tray, and then pull it out of the printer.

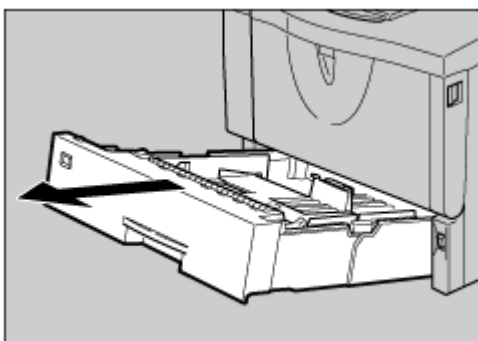

ZK03Y1-03E



**3** Load paper into the tray with the print side down.

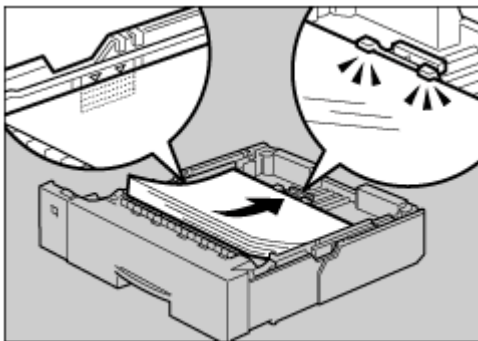

Z60Y150E

**★ Important**

- Confirm that the top of the stack is not higher than the limit mark inside the tray.
- Confirm that paper fits under the rear guide.

**4** Lift the front of the tray, and then slide it carefully into the printer until it stops.

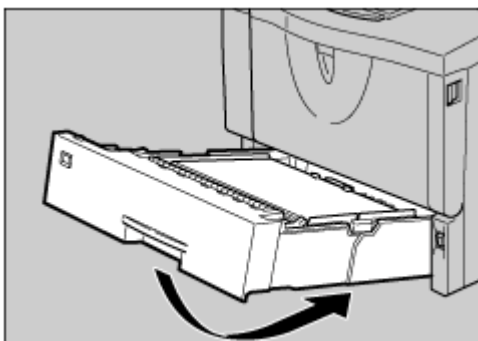

Z60Y150E

**★ Important**

- Do not slide the paper tray in with force. If you do, the front and side guides might move.

**☰ Reference**

For more information about type, size and feed direction of paper that can be loaded in the tray, see [p.5 "Paper and Other Media Supported by This Printer"](#).

When you change the paper size see [p.18 "Changing the paper size"](#).

## Changing the paper size

**★ Important**

- ❑ Confirm that the setting of the paper size dial matches the paper size and feed direction of the paper in the tray, otherwise the printer might be damaged, or printing problems might occur.

The following explanation uses the example of “Tray 1” for the paper tray.

- 1** Lift the paper tray slightly, and then pull it out until it stops. Adjust the paper size dial to match the size and feed direction of paper in the paper tray.

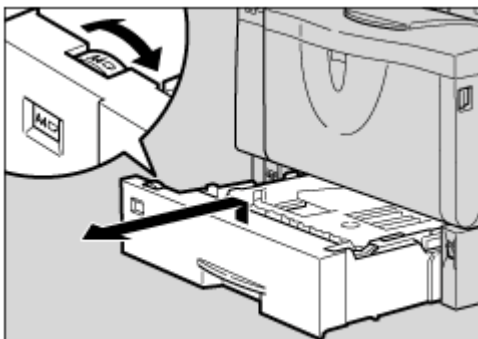

26031-40E

**★ Important**

- ❑ If you want to use the paper size and feed direction that are not indicated on the paper size dial, set the dial to “✖”. In this case, you should set the paper size using the control panel.

- 2** Lift the front side of the tray, and then pull it out of the printer.

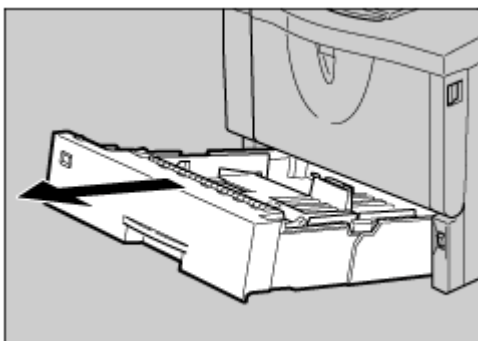

26031-40E

- 3** If you load paper larger than A4 or 8<sup>1</sup>/<sub>2</sub> × 11, you should extend the tray as follows:

**↓ Note**

- ❑ You cannot load paper smaller than A4 or 8<sup>1</sup>/<sub>2</sub> × 11, if the tray is extended. In this case, return the tray to its standard length.

**4** Slide the catches inwards to unlock the tray.

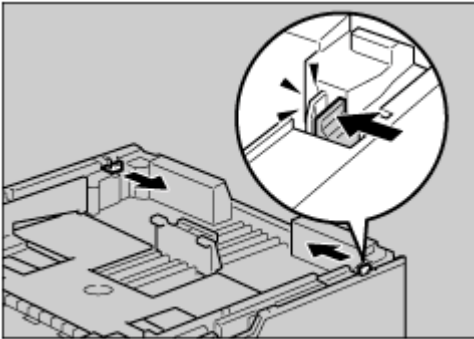

Z603Y160E

**5** Slide the tray until it stops.

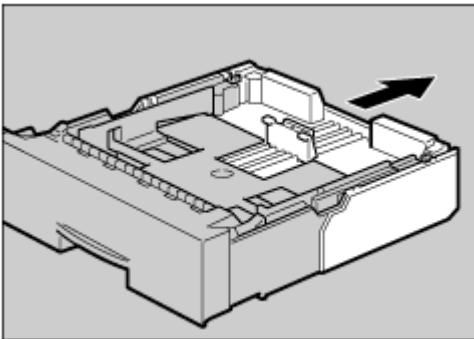

Z603Y170E

**6** Return the catches to their original positions.

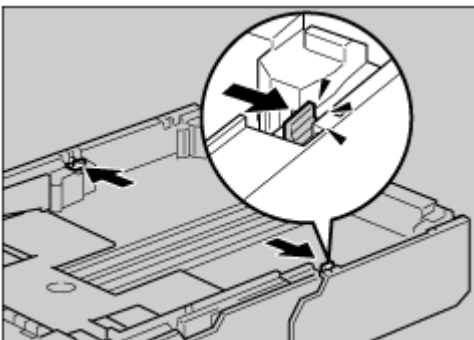

Z603Y180E

**★ Important**

- Confirm that the catches return to their original positions securely. If they are not locked securely, paper misfeeds might occur.

**7** Adjust the rear and side guides to the paper size you want to load.

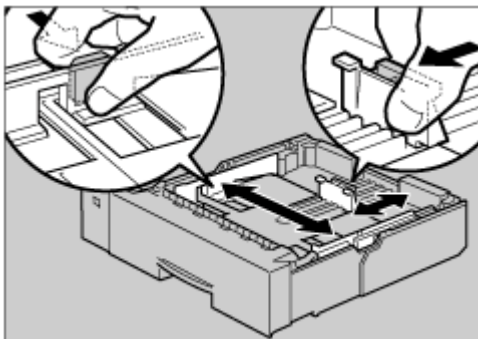

Z603Y130E

**★ Important**

- ❑ To avoid damage, pinch the paper guides when moving them.

**8** Load paper into the tray with the print side down.

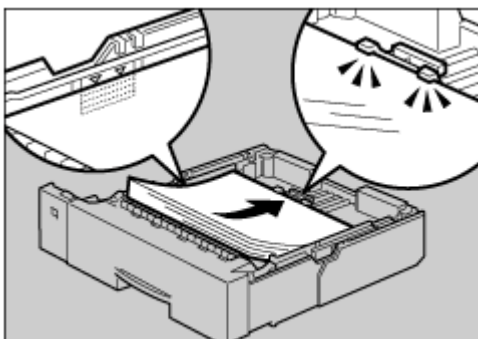

Z603Y130E

**★ Important**

- ❑ Confirm that the top of the stack is not higher than the limit mark inside the tray.
- ❑ Confirm that paper fits under the rear guide.

**9** Lift the front side of the tray, and then place it into the printer. Carefully slide it into the printer until it stops.

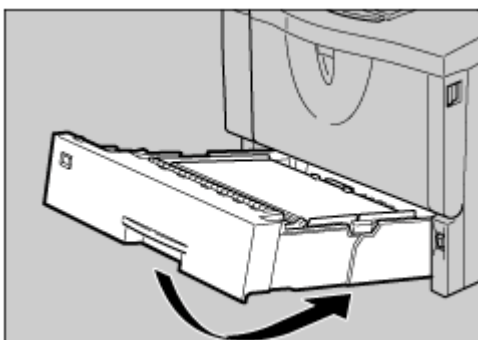

Z603Y150E

**★ Important**

- ❑ Do not slide the paper tray in with force. If you do, the front and side guides might move.

**10** Attach the paper tray cover provided when you have pulled out the tray extension.

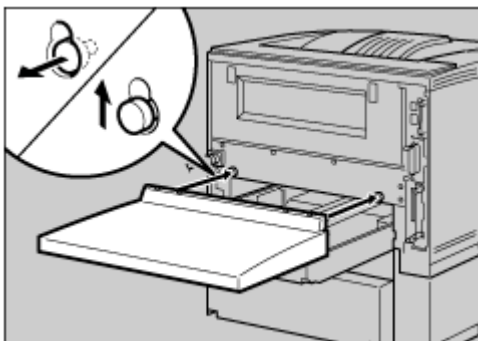

ZK0H241E

**↓ Note**

- ❑ The paper tray cover contains four mounting holes.
  - Use the two outer holes when attaching the paper tray cover as a cover for the standard tray.
  - Use the two inner holes when attaching the paper tray cover as a cover for an additional tray.

**If you load a paper size that is not selected automatically**

To load paper whose size cannot be selected automatically, set the paper size on the control panel. Follow the procedure described below to set the paper size.

**1** Press the [Menu] key.

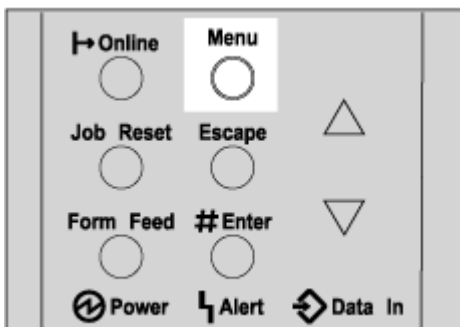

AGN5005

The [Menu] screen appears on the display.

- 2** Press the [▲] or [▼] key to display [Paper Input], and then press the [# Enter] key.

```
Menu:
  Paper Input
```

The paper selection menu appears.

- 3** Press the [▲] or [▼] key to display [Tray Paper Size], and then press the [# Enter] key.

The paper tray selection menu appears.

- 4** Press the [▲] or [▼] key to display the target paper tray, and then press the [# Enter] key.

```
Tray Paper Size:
  Tray 2
```

The paper size selection menu appears.

- 5** Press the [▲] or [▼] key to display the loaded paper size, and then press the [# Enter] key.

```
Tray 2:
  8 1/2 x 13
```

After about two seconds, the display returns to the menu.

- 6** Press the [Online] key.

The initial screen appears.

This completes the setting change.

### Specifying custom size paper for the optional paper feed unit

**★ Important**

- When printing on custom size paper, specify the paper size using the control panel or printer driver.
- The custom size paper selected using the printer driver overrides that selected using the control panel. Do not make settings using the control panel if you have already made settings using the printer driver. However, when printing with a printer driver other than the RPCS printer driver, you must configure the settings using control panel.
- The following is the range of paper sizes that can be loaded in each type of the paper trays:
  - Optional paper feed unit (Tray 2, Tray 3): 7.17 - 11.69 inches in width and 6.30 - 17.01 inches in length.

- ❑ The printer cannot print from applications that do not support custom size paper.

**1** Press the [Menu] key.

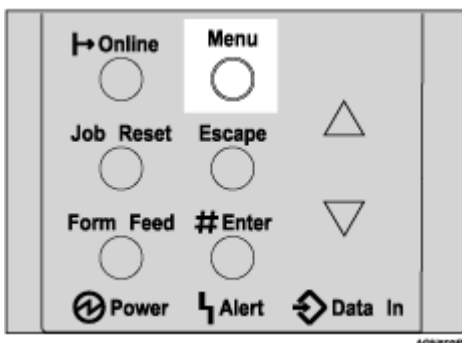

The [Menu] screen appears on the display.

**2** Press the [▲] or [▼] key to display [Paper Input], and then press the [# Enter] key.

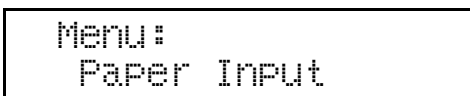

The paper selection menu appears.

**3** Press the [▲] or [▼] key to display [Tray Paper Size], and then press the [# Enter] key.

The paper tray selection menu appears.

**4** Press the [▲] or [▼] key to display the target paper tray, and then press the [# Enter] key.

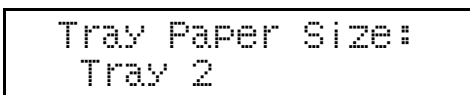

The paper size selection menu appears.

**5** Press the [▲] or [▼] key to display [Custom Size], and then press the [# Enter] key.

**6** Press the [▲] or [▼] key to set horizontal value, and then press the [# Enter] key.

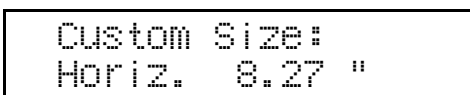

Press the [▼] or [▲] key scrolls the value in increments of 0.01 inch. Pressing the [▼] or [▲] key scrolls the value in increments of 0.1 or 1 inch.

The screen for entering the length appears.

- 7** Press the [▲] or [▼] key to set the vertical value, and then press the [# Enter] key.

```

Custom Size:
Vert.  11.69 "
  
```

After about two seconds, the display returns to the menu.

- 8** Press the [Online] key.

The initial screen appears.

### Specifying a paper type for paper tray and the optional paper feed unit

Improve printer performance by selecting the optimum paper type for the tray. You can select from the following paper types:

- Plain Paper, Recycled Paper, Special Paper, Color Paper, Letterhead.

- 1** Press the [Menu] key.

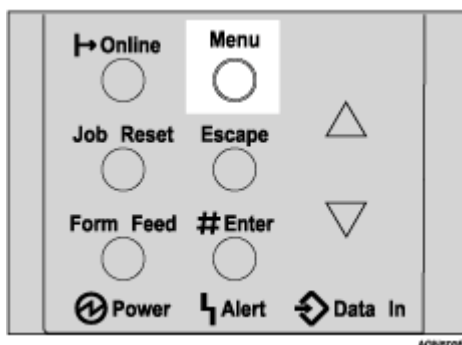

The [Menu] screen appears on the display.

- 2** Press the [▲] or [▼] key to display [Paper Input], and then press the [# Enter] key .

```

Menu:
Paper Input
  
```

The paper type selection menu appears.

- 3** Press the [▲] or [▼] key to display [Paper Type], and then press the [# Enter] key .

The paper tray selection menu appears.

- 4** Press the [▲] or [▼] key to display the target paper tray, and then press the [# Enter] key .



When the optional paper feed units are installed in the printer, **[Tray 2]** and **[Tray 3]** will appear depending on the number of the installed units.

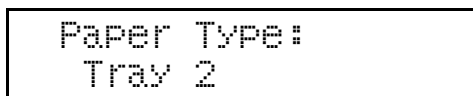

The paper type selection menu appears.

**5** Press the **[▲]** or **[▼]** key to display the target paper tray, and then press the **[# Enter]** key .

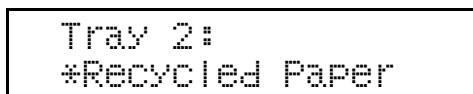

After about two seconds, the display returns to the menu.

**6** Press the **[Online]** key.

The initial screen appears.



- The following paper types cannot be printed on both sides:
  - Special Paper, Color Paper, Preprinted.

---

## Loading Paper in the Bypass Tray

---

### Opening and Closing the Bypass Tray

---

Open the bypass tray

---

**1** Open the bypass tray.

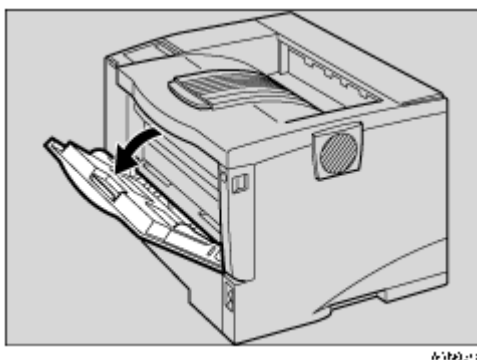

Close the bypass tray

---

When you have finished using the bypass tray, close it as shown in the next step.

**1** Close by pressing the mark in the center of the bypass tray.

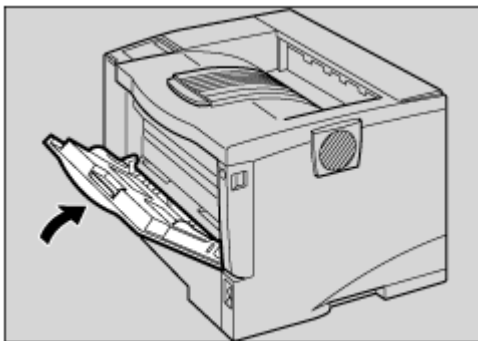

### Specifying standard size paper for the Bypass Tray

---

**★ Important**

- Shuffle the paper before loading the stack onto the tray, so multiple sheets are not fed in together.
- Set the size and direction of the loaded paper on the control panel or with the printer driver. Make sure the settings do not conflict. Otherwise, the paper may jam or the print quality may be affected.

**1** Slide the side guides outward, and load paper until it stops with the print side up.

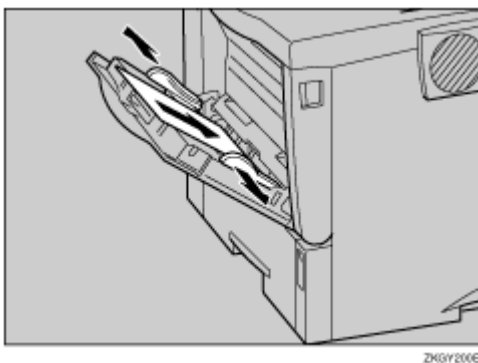

**Note**

- ❑ If you load A4 or larger, or 8 1/2 x 11 or larger, slide out the bypass tray extension (1) and then flip it open (2).

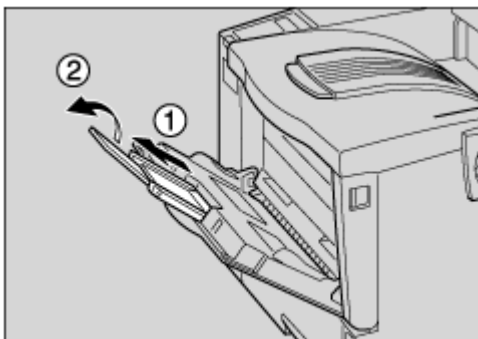

ZK6Y220E

**2 Adjust the side guides to the paper width.**

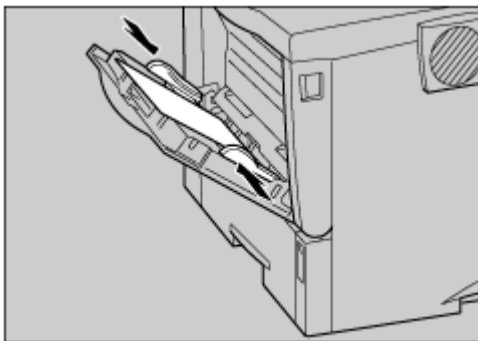

ZK6Y220E

**★ Important**

- ❑ Confirm that paper fits under the side guides.
- ❑ Sheets of A4 or 8 1/2 x 11 length or longer must be loaded one at a time. Support the paper by hand so it feeds in properly. Additionally, since paper feeding and image quality may differ depending on paper thickness and width, check print results in advance using paper you intend to print on.

**Note**

- ❑ 45 kg paper or paper of A4 or 8 1/2 x 11 or longer may not feed in properly unless it is cut at right angles.

- 3** To set the paper size and feed direction, Press the [Menu] key.

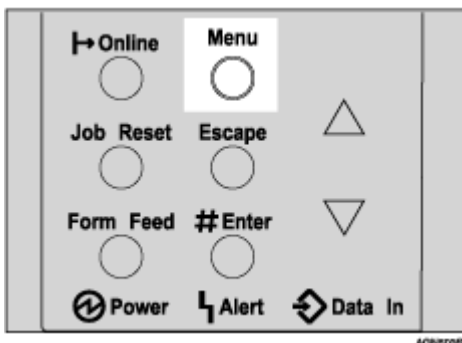

The [Menu] screen appears on the display.

- 4** Press the [▲] or [▼] key to display [Paper Input], and then press the [# Enter] key.

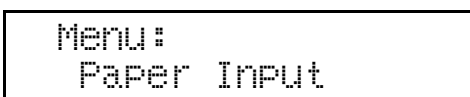

The paper selection menu appears.

- 5** Check [Bypass Size] appears, and then press the [# Enter] key.

The paper size selection menu appears.

- 6** Press the [▲] or [▼] key to display the size and orientation of the paper in the bypass tray.

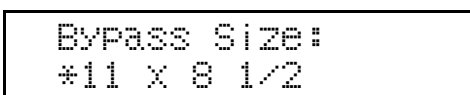

After about two seconds, the display returns to the menu.

- 7** Press the [Online] key.

The initial screen appears.



- To load thick paper, OHP transparencies, or envelopes, make settings for thick paper or OHP transparencies using the control panel and printer driver.
- The number of pages that can be loaded in the bypass tray differs depending on paper type. Make sure paper is not stacked above the paper guides inside the bypass tray.



For details about control panel settings for custom size paper or special paper, see [p.29 “Specifying custom size paper for the Bypass Tray”](#).

For control panel settings when using thick paper, OHP transparencies, or post cards, see [p.30 “Specifying a paper type for the Bypass Tray”](#).

## Specifying custom size paper for the Bypass Tray

### ★ Important

- ❑ The settings of custom sized paper that take effect are not the settings made on the control panel but the settings made in the printer driver. There is no need to change the settings on the control panel. However, when using a printer driver other than RPCS, you will need to change the settings on the control panel.
- ❑ Applications that do not allow a custom paper size to be set cannot print on custom sized paper.

### ↓ Note

- ❑ If you print on A3 or longer sheets, prints may become blurred.

### 1 Press the [Menu] key.

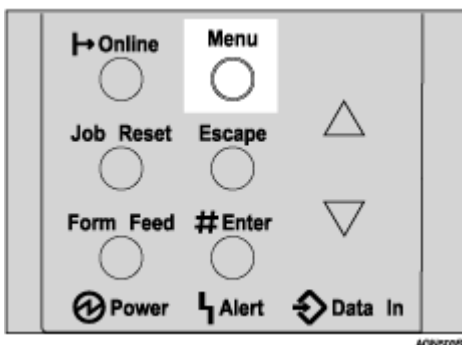

The [Menu] screen appears on the display.

### 2 Press the [▲] or [▼] key to display [Paper Input], and then press the [# Enter] key.

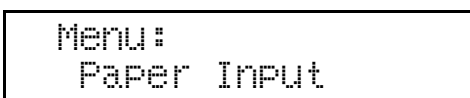

The paper selection menu appears.

### 3 Check [Bypass Size] appears, and then press the [# Enter] key.

The paper size selection menu appears.

### 4 Press the [▲] or [▼] key to display [Custom Size], and then press the [# Enter] key.

- 5** Press the [▲] or [▼] key to set the horizontal value, and then press the [# Enter] key.

```
Custom Size:
Horiz.  8.27 "
```

By pressing the key, the value increases or decreases by 0.01 inch. By pressing and holding the key, the value varies by 0.1 inch or 1 inch.

- 6** Press the [▲] or [▼] key to set the vertical value, and then press the [# Enter] key.

```
Custom Size:
Vert.   11.69 "
```

After about two seconds, the display returns to the menu.

- 7** Press the [Online] key.

The initial screen appears.



For details about the printer driver, see the printer driver Help.

## Specifying a paper type for the Bypass Tray

---

By selecting the paper type you want to load, the printer performs better. You can select from the following paper types:

- Plain Paper, Recycled Paper, Special Paper, Color Paper, Letterhead, Transparency, Thick Paper.

### ★ Important

- When you load Thick Paper or transparencies in the Bypass Tray, always specify the type of paper. Duplex printing is not possible on paper in a tray for which Thick Paper or Transparency has been set.
- The paper type selected using the printer driver overrides that selected using the control panel.

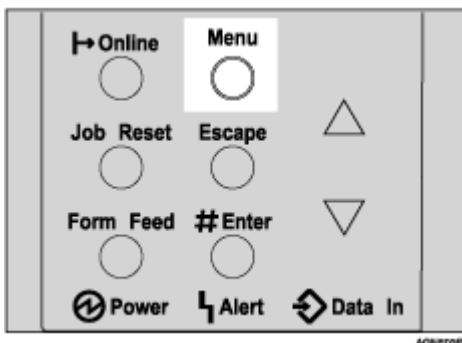
**1 Press the [Menu] key.**

The [Menu] screen appears on the display.

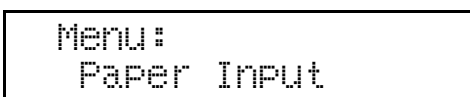
**2 Press the [▲] or [▼] key to display [Paper Input], and then press the [# Enter] key .**

The paper selection menu appears.

**3 Press the [▲] or [▼] key to display [Paper Type], and then press the [# Enter] key.**

The paper tray selection menu appears.

**4 Press the [▲] or [▼] key to display [Bypass Tray], and then press the [# Enter] key.**

The paper type selection menu appears.

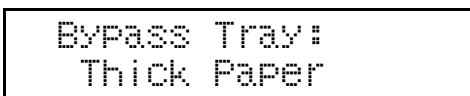
**5 Press the [▲] or [▼] key to display the type of paper you have loaded, and then press the [# Enter] key .**

After about two seconds, the display returns to the menu.

**6 Press the [Online] key.**

The initial screen appears.



- The following paper types cannot be printed on both sides:
  - Special Paper, Color Paper, Preprinted, Transparency, Thick Paper.

## Loading Envelopes

As there are many kinds of envelopes, be sure to check if those to be used are supported by this printer.

### Reference

For more information about envelopes, see [p.12 “Envelopes”](#).

### Important

- Even if the optional envelope feeder is not installed, you can select envelope sizes for Tray 2 and Tray 3 using the control panel. However, you cannot load envelopes until the optional envelope feeder unit is installed.
- To install the envelope feeder unit, the optional paper feed unit must be installed. See “Attaching Envelope Feeder Type 610”, Setup Guide.

## Loading envelopes onto the Bypass Tray

### Reference

With the bypass tray, you can load up to 10 envelopes at the same time. For more information about envelopes, see [p.12 “Envelopes”](#).

To open and close the bypass tray, see [p.25 “Opening and Closing the Bypass Tray”](#).

- 1** Load envelopes until they stop, with the print side up and the sides of the flaps on the left as shown below.

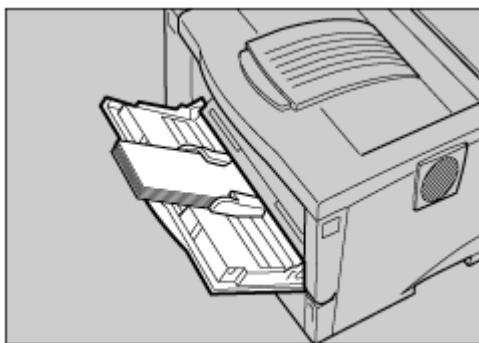

ZK3Y411E

### Important

- Confirm that the envelope flaps are securely folded down, and that there is no air inside the envelopes.

### Note

- Confirm that the top of the stack is not higher than the limit mark on the side guides.
- Do not push the stack of envelopes with too much force.

- 2** Slide the side guides against the edge of the envelope stack.



**Note**

- Confirm that the edges of envelopes fit under the side guides.

**3 Set the envelope size and feed direction. Press the [Menu] key.**

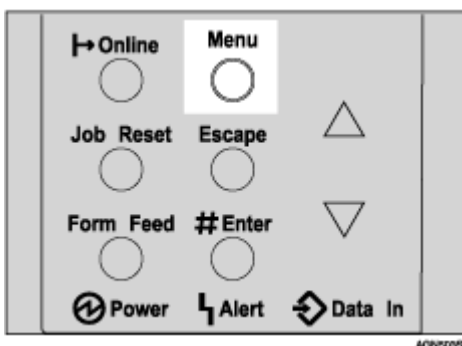

The [Menu] screen appears on the display.

**4 Press the [▲] or [▼] key to display [Paper Input], and then press the [# Enter] key.**

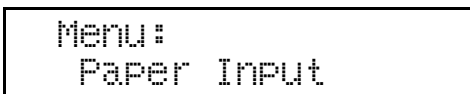

The paper selection menu appears.

**5 Check [Bypass Size] appears, and then press the [# Enter] key.**

The paper size selection menu appears.

**6 Press the [▲] or [▼] key to select the envelope type you want to use.**

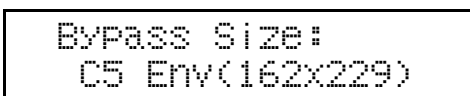

**Reference**

For information about types of envelopes you can select, see [p.5 “Paper and Other Media Supported by This Printer”](#).

**7 Press the [# Enter] key to apply the settings. Wait for a while.**

After about two seconds, the display returns to the menu.

**8 Press the [Online] key.**

The initial screen appears.

## Loading envelopes into the Envelope Feeder Unit

### ★ Important

- With the optional envelope feeder unit, you can load up to 60 envelopes at the same time. For more information about envelopes, see [p.12 “Envelopes”](#).

The following explanation uses the example of installing the envelope feeder unit in “Tray 2”.

- 1** Slide the optional paper feed unit (Tray 2) out until it stops. Then, lift it slightly, and then slide it out.

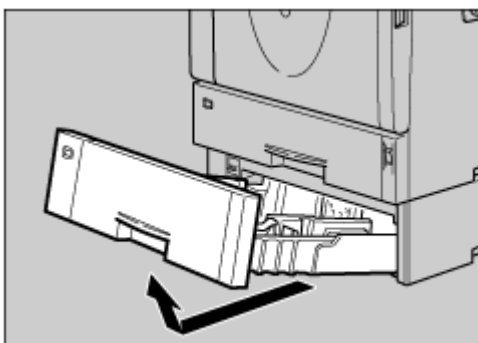

ZK3P330E

### ↓ Note

- Keep the paper tray with paper in a cool and dry place.

- 2** Prepare the envelope feeder Unit.
- 3** Pinch the side guides, and then slide them outward until they stop. Pinch the rear guide, and then slide it toward the back.

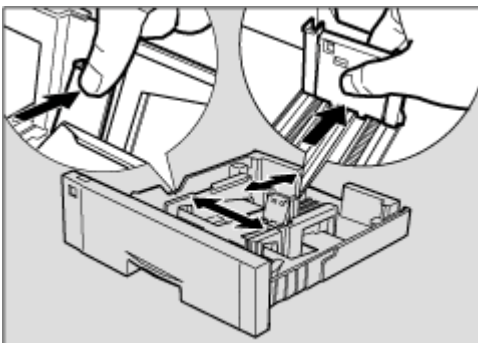

ZK3Y200E

- 4** Push the bottom plate down until it locks into place.

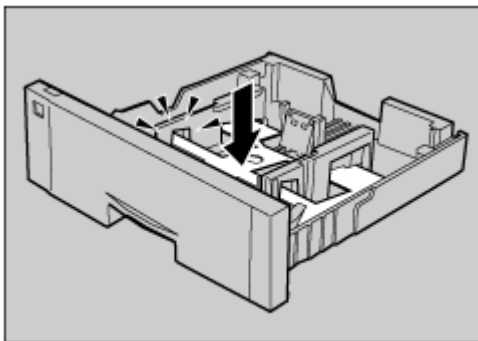

ZK0P380E

- 5** Load envelopes into the envelope feeder unit, with the print side down and the flap on the left as shown in the illustration.

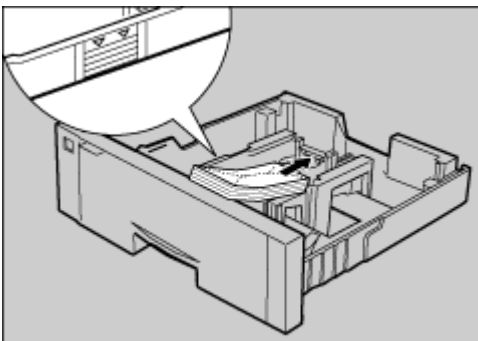

ZK0P380E

**★ Important**

- Confirm that the envelope flaps are securely folded down, and that there is no air inside the envelopes.

**↓ Note**

- Confirm that the top of the stack is not higher than the limit mark on the side guides.
- Confirm that the envelopes fit under the side guides.
- Do not push the stack of envelopes with too much force.

- 6** Pinch the side guides, and then slide them along the edge of the envelope stack.

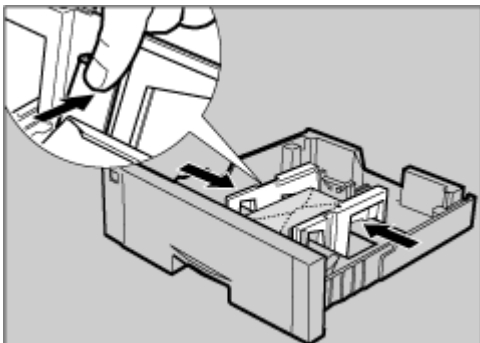

ZK0Y370E

- 7** Pinch the rear guide, and then slide it along the edge of the envelope stack.

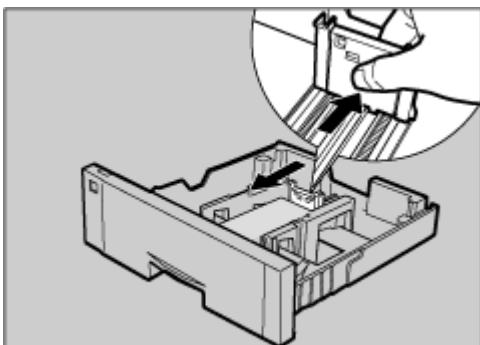

ZK0Y380E

- 8** Lift the front of the tray, and then slide it carefully into the printer until it stops.

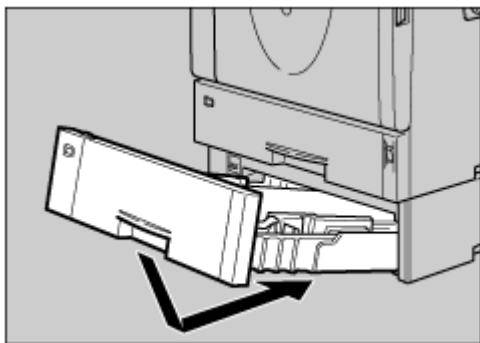

ZK0P340E

**★ Important**

- Do not slide the paper tray in with force. If you do, the front and side guides might move.

- 9** Press the [Menu] key.

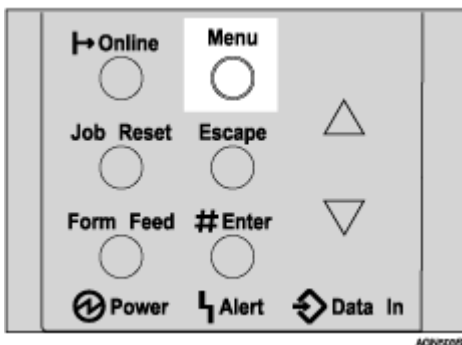

The [Menu] screen appears on the display.

- 10** Press the [▲] or [▼] key to display [Paper Input], and then press the [# Enter] key.

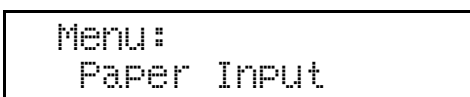

The paper selection menu appears.

- 11** Press the [▲] or [▼] key to display [Tray Paper Size], and then press the [# Enter] key.

The paper tray selection menu appears.

- 12** Press the [▲] or [▼] key to display the target paper tray, and then press the [# Enter] key.

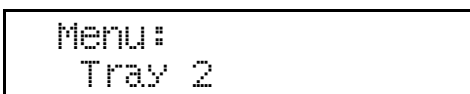

The paper size selection menu appears.

- 13** Press the [▲] or [▼] key to select the envelope type you want to use.

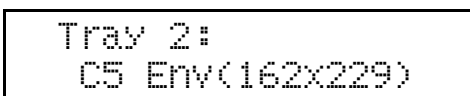

**Reference**

For more information about types of envelopes you can select, see [p.5 “Paper and Other Media Supported by This Printer”](#).

- 14** Press the [# Enter] key to apply the settings. Wait for a while.

After about two seconds, the display returns to the menu.

- 15** Press the [Online] key.

The initial screen appears.

## Switching between Paper Trays

When paper of the same size is loaded in both the standard tray and the paper feed unit (option), paper will be fed from the standard tray when you start printing. To print on paper loaded in the paper feed unit, switch the tray to be used to the paper feed unit using [Tray Priority] in the [Paper Input] menu.

- 1 Press the [Menu] key.

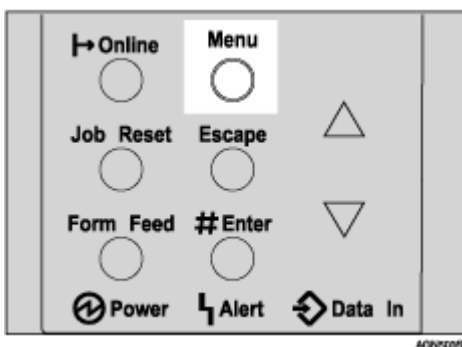

The [Menu] screen appears on the display.

- 2 Press the [▲] or [▼] key to display [Paper Input], and then press the [# Enter] key.

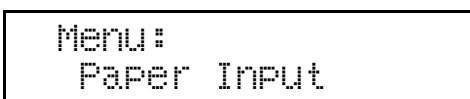

The paper selection menu appears.

- 3 Press the [▲] or [▼] key to display [Tray Priority], and then press the [# Enter] key.

The paper tray selection menu appears.

- 4 Press the [▲] or [▼] key to select the tray type you want to use, and then press the [# Enter] key.

The following message appears on the display:

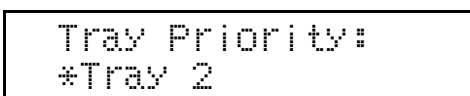

- 5 Press the [Online] key.

The initial screen appears.

# Replacing the Toner Cartridge

## **⚠ WARNING**

- ***Do not incinerate spilled toner or used toner. Toner dust is flammable and might ignite when exposed to an open flame.***
- ***Disposal should take place at an authorized dealer or an appropriate collection site.***
- ***If you dispose of the used toner cartridges yourself, dispose of them according to local regulations.***
- ***Do not store toner, used toner, or toner containers in a place with an open flame. The toner might ignite and cause burns or a fire.***

## **⚠ CAUTION**

- *Keep toner (used or unused) and the toner cartridge out of reach of children.*
- *If toner or used toner is inhaled, gargle with plenty of water and move into a fresh air environment. Consult a doctor if necessary.*
- *If your skin comes into contact with toner or used toner, wash the affected area thoroughly with soap and water.*
- *If toner or used toner gets into your eyes, flush immediately with large amounts of water. Consult a doctor if necessary.*

## **⚠ CAUTION**

- *If toner or used toner is swallowed, dilute by drinking a large amount of water. Consult a doctor if necessary.*
- *Avoid getting toner on your clothes or skin when removing a paper jam or replacing toner. If your skin comes into contact with toner, wash the affected area thoroughly with soap and water.*
- *If toner gets on your clothing, wash with cold water. Hot water will set the toner into the fabric and may make removing the stain impossible.*

Replace the toner cartridge if the following message appears on the display:

Replace  
Toner Cartridge

## **★ Important**

- ❑ **Do not expose the toner cartridge to light for a long time. Do not leave the front cover open for a long time. If the toner cartridge is exposed to a light for a long time, the toner cartridge might be damaged and print quality might be reduced.**

↓ Note

- ❑ When handling toner cartridges, never stand them up on either end or position them upside down.
- ❑ Store toner cartridges in a cool dark place.
- ❑ Actual printable numbers vary depending on image volume and density, number of pages printed at a time, paper type and size, and environmental conditions such as temperature and humidity. Toner quality degrades over time. You may have to replace the toner cartridge prematurely. We recommend you prepare a new toner cartridge beforehand.

**1** Open the front cover by pushing the front cover release button.

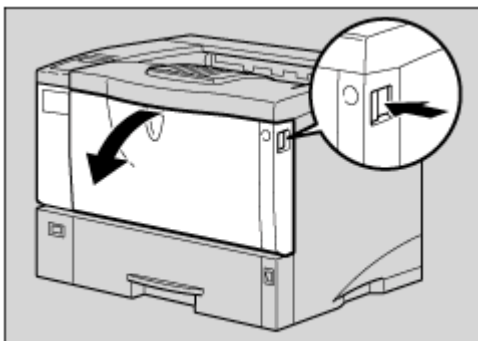

40982276

**2** Be sure to put the toner cartridge on a stable, flat surface.

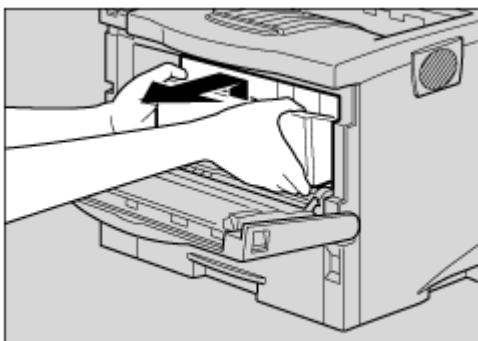

40982276

↓ Note

- ❑ Do not put the toner cartridge on an unstable or tilted surface.



- 3** Wipe around the metallic registration roller by turning with a soft damp cloth.

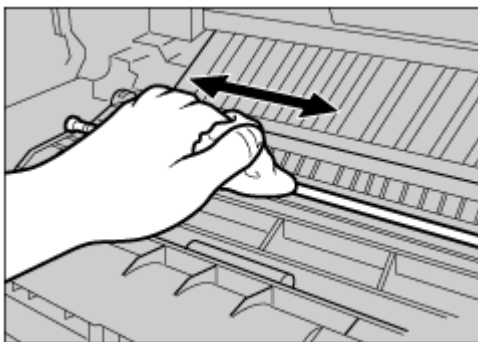

ZK32461E

**★ Important**

- Do not use chemical cleaner or organic solvent such as thinner or benzene.

- 4** Take the new toner cartridge from the box.

- 5** Place the toner cartridge on a flat surface. Pull out the tape inside the unit horizontally while holding the cartridge with one hand as shown in the illustration.

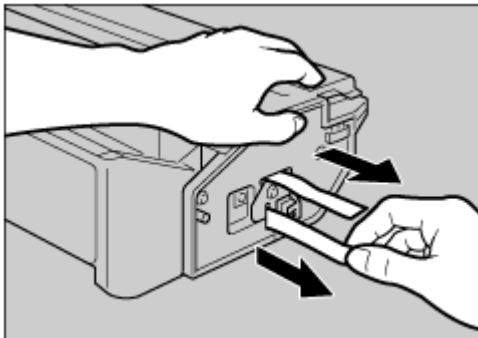

ZKGT161E

**↓ Note**

- Be sure to remove the tape completely before installing the new toner cartridge, otherwise the printer might be damaged.
- Keep the toner cartridge horizontal when pulling out the toner seal. Pulling out the toner seal with the cartridge upright or tilted can cause printer failure.
- Be careful not to get toner dust on your hands or clothes.
- Do not shake or shock the toner cartridge after pulling out the toner seal to avoid dirt on paper surfaces, toner spillage, or printer failure.

- 6** Hold the grips of the cartridge, and then insert it into the printer until it stops.

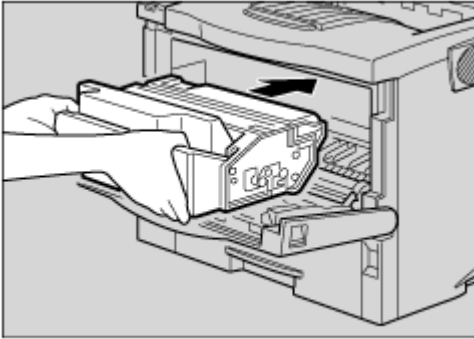

2014 215

- 7** Push down the toner cartridge to settle it in appropriate position.

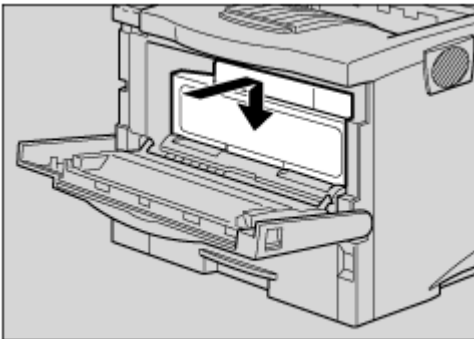

2014 216

- 8** Close the front cover by pressing the left and right side indentations.

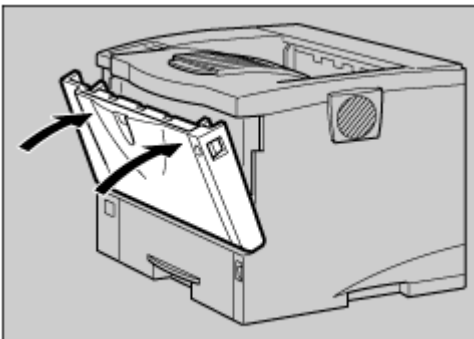

ZK6H130E

**★ Important**

- Do not close the front cover with force. If you cannot close the cover easily, pull out the toner cartridge from the printer and insert it again. After that, close the front cover again.

↓ Note

- Please cooperate with the toner cartridge recycling program, whereby are collected used toner cartridges. For details, consult with the store where the printer was purchased or with a sales or service representative.

# Replacing the Maintenance Kit

## WARNING

- *Do not risk electric shock by handling the power cord or plug with wet hands.*

## CAUTION

- *The inside of this printer becomes very hot. Do not touch parts labelled “” (indicating a hot surface). Touching these parts will result in burns.*
- *Grip the plug, not the cord, when pulling the plug from the socket. Pulling the cord causes wear and tear that can result in fire or electric shock.*
- *Wait at least one hour after power off before replacing parts. Not allowing the printer to cool may result in burns.*

The maintenance kit contains parts for maintaining the printer.

Replace the maintenance kit if the following message appears on the display:



Replace  
Maintenance Kit

---

## Before Replacing

---

Replace all the parts included in Maintenance Kit at the same time. Replace them according to the following procedure.

### **1** Turn off the power, and then unplug the power cable.

#### Important

- Wait at least an hour after power off to allow internal parts to cool down before replacing the Maintenance Kit.

### **2** Check the box contains the following items:

- Friction Pad × 3  
See [p.45 “Replacing the Friction Pad”](#).
- Transfer Roller (with gloves)  
See [p.47 “Replacing the Transfer Roller”](#).
- Paper Feed Roller × 3  
See [p.50 “Replacing the Paper Feed Rollers”](#).
- Fusing Unit  
See [p.53 “Replacing the Fusing Unit”](#).

## Replacing the Friction Pad

Replace all friction pad of the tray. There are two kinds of friction pads. One is for the paper tray (Tray 1), and the other are for the paper feed unit(s) (Tray 2, 3). The following procedure shows how to replacing friction pad of the paper tray (Tray1).

- 1** Lift the paper tray slightly, and then pull it out until it stops.

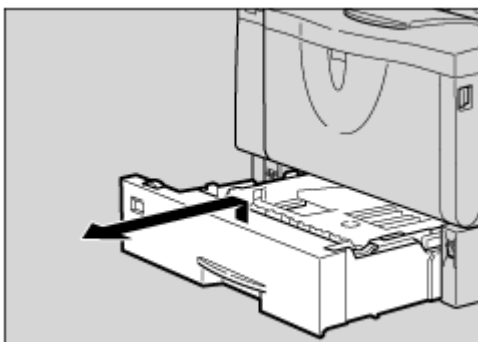

ZK31140E

- 2** Lift the front side of the tray, and then pull it out of the printer.

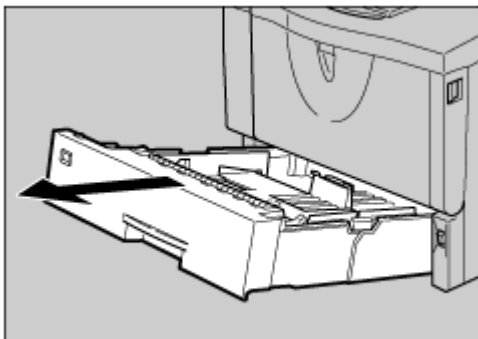

ZK31140E

- 3** Remove paper from the paper tray. Place the tray upside down on a flat surface.

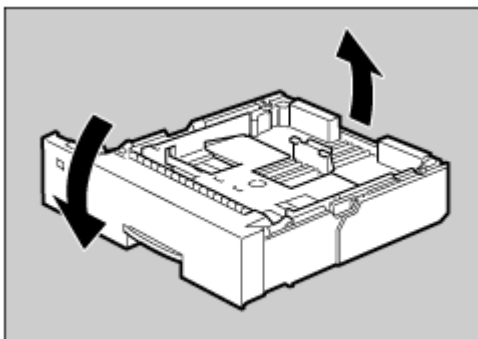

ZK31140E

**4 Use a sharp-pointed item like a ball-point pen, to release the two catches that lock the friction pad.**

↓ Note

- The friction pad may fall off when the catches are released. Place your hand over the friction pad while releasing the catches.
- The friction pad spring may come off. Be careful not to lose the friction pad spring.
- The catches that lock the friction pad are located at the very back.

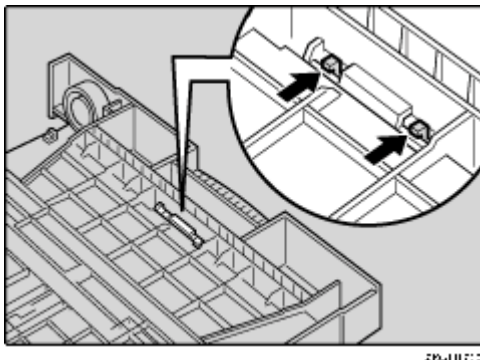

**5 Return the paper tray to its original position, and then remove the friction pad from the tray.**

↓ Note

- The friction pad spring may come off. Be careful not to lose the friction pad spring.

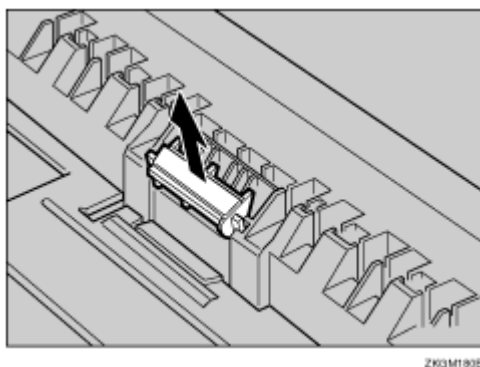

**6 Insert the new friction pad in the paper tray.**

Attach the center projection of the new friction pad to the spring, and then align the projection of both sides of the friction pad to the holes of the paper tray. Then push the friction pad as shown in the illustration until it clicks.

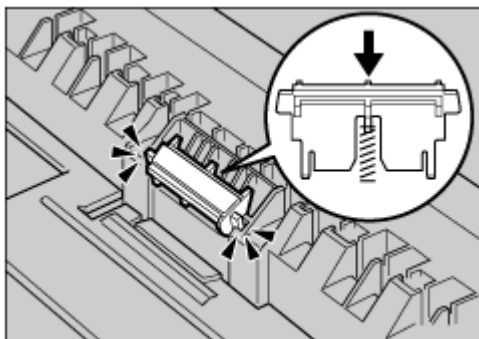

ZK3M193E

After pushing in the friction pad, try pushing it several times to check it is properly installed. If it jumps back into position due to the force of the spring, it is properly installed.

- 7** Push the friction pad until it locks securely.
- 8** If your printer is equipped with the optional paper feed unit(s), follow the same procedure when replacing the friction pad.

---

## Replacing the Transfer Roller

---

- 1** Open the front cover by pushing the front cover release button.

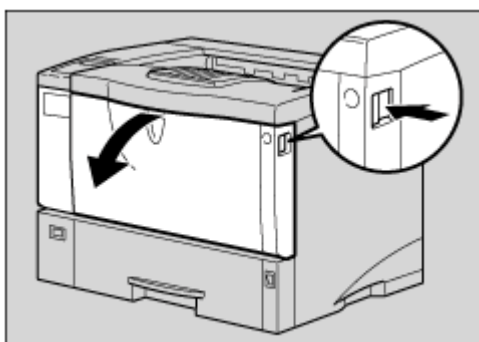

ZK3M193E

- 2** Pull the toner cartridge out of the printer, while lifting the front side.

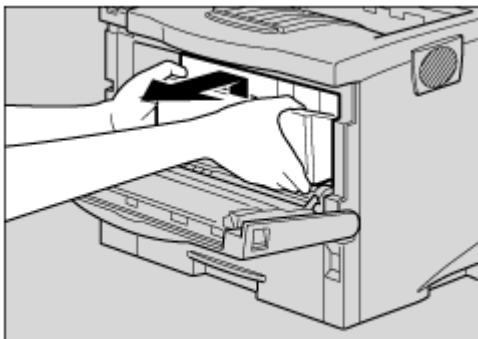

↓ Note

- Be sure to place the used cartridge on the level place.

- 3** To avoid making your hands dirty with toner from the transfer roller, wear the gloves included in the maintenance kit.

- 4** Hold the lock levers (“O” parts), and then pull them.

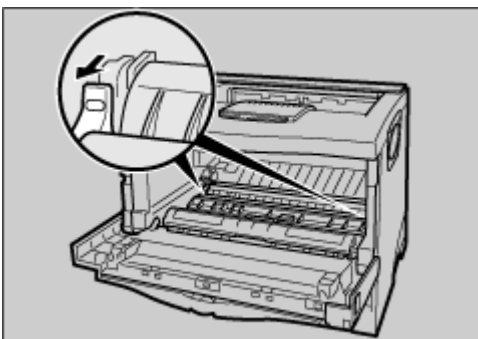

- 5** Hold the green parts of the roller on both sides, and then remove the roller from the printer as shown in the illustration.

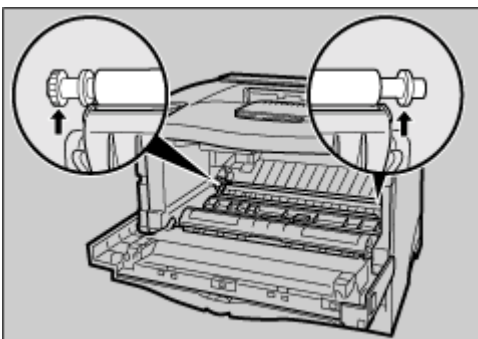



- 6** Insert the new transfer roller on the socket with the gear of the roller positioned on the left.

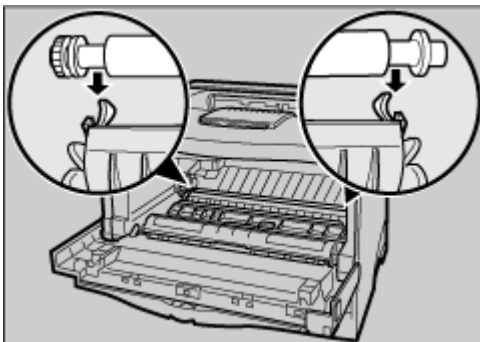

ZK3M20E

**★ Important**

- Do not insert the roller on the back of the socket, or the printer might be damaged.
- Insert the metallic part of the roller on the socket. If you insert the sponge part of the roller, the roller might be damaged.

- 7** Push down the green parts of both sides of the printer until it clicks as shown in the illustration.

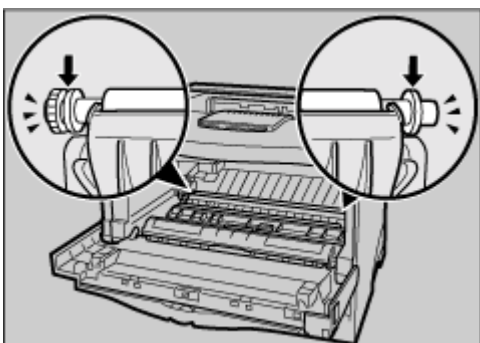

ZK3M21E

**↓ Note**

- When the transfer roller is set, the transfer roller cover will return to its original position automatically.

- 8** Take the gloves off.

- 9** Hold the grips of the toner cartridge, and then insert it into the printer until it stops.

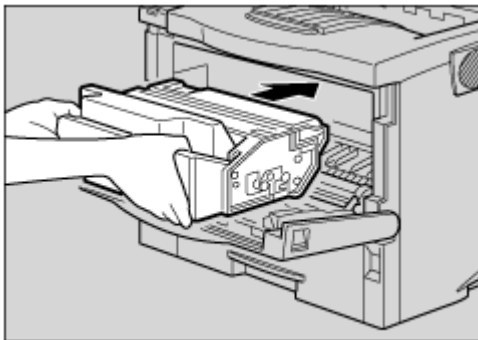

2014 © Ricoh

- 10** Lower the toner cartridge when it touches the back.

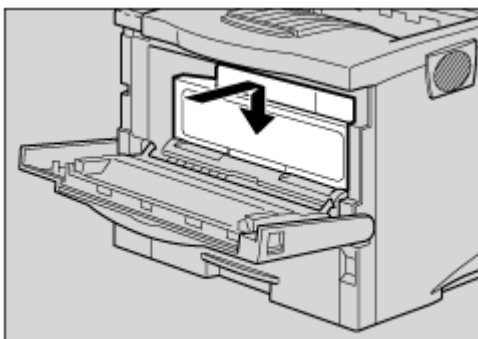

2014 © Ricoh

- 11** Close the front cover by pressing the left and right side indentations.

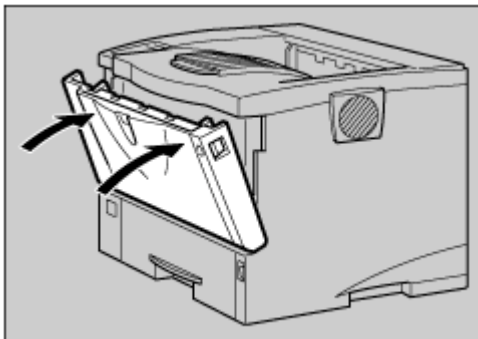

ZK6H130E

---

## Replacing the Paper Feed Rollers

---

Replace all feed rollers including the printer and the optional paper feed unit(s). The following procedure shows how to replace the printer's paper feed rollers.

**⚠ CAUTION**

- *When lifting the machine, use the inset grips on both sides. Otherwise the printer could break or cause injury if dropped.*

**⚠ CAUTION**

- *Lifting the paper feed unit carelessly or dropping it may cause injury.*

**★ Important**

- The following are examples of replacing the paper feed roller on the paper tray.
- You can replace the paper feed roller on the optional paper feed unit by following the procedures below. The paper feed roller on the optional paper feed unit differs from the one on the paper tray. Confirm the type of paper feed roller you are installing.

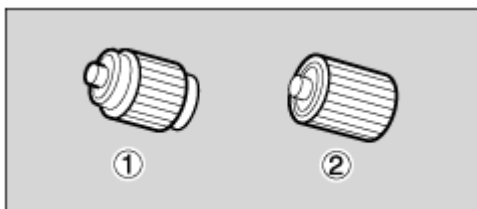

- ① For the paper tray
- ② For the paper feed unit

**1** If the optional duplex unit is installed, uninstall them from the printer.

**2** Move the printer to the edge of a sturdy and stable table or desk.

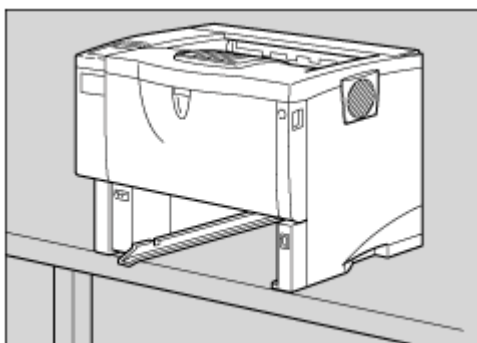

**★ Important**

- Always move the printer horizontally. Moving the printer facing up on down may cause the toner to scatter.
- Do not put the printer on an unstable or tilted surface.

↓ Note

- ❑ If the printer is equipped with the optional paper feed unit, do not move the printer and the unit together, because they are not securely attached.

**3** Slide the green lock lever to the left (①), and then remove the paper feed roller (②).

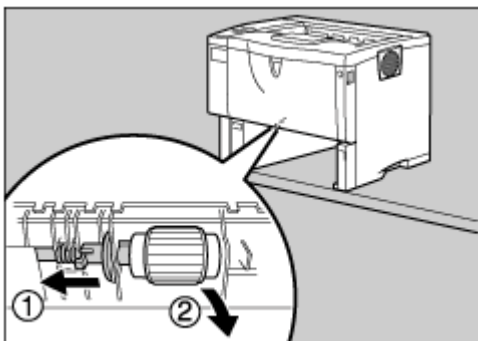

**4** While sliding the green lock lever to the left (①), set the new roller (②). Then return the green lock lever to its original position (③).

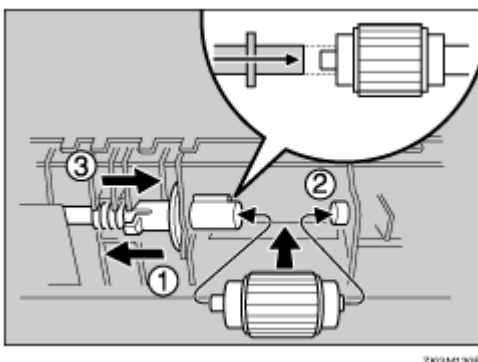

↓ Note

- ❑ Check the green lock lever secures the roller correctly by making sure the new roller rotates smoothly.

**5** If the printer is equipped with the optional paper feed unit(s), follow the same procedure when replacing the paper feed roller.

If you installed two paper feed units, also replace both paper feed rollers.

- 6 Place paper in the paper trays and additional removed paper trays. Lift the front of the tray, and then slide it carefully into the printer until it stops.

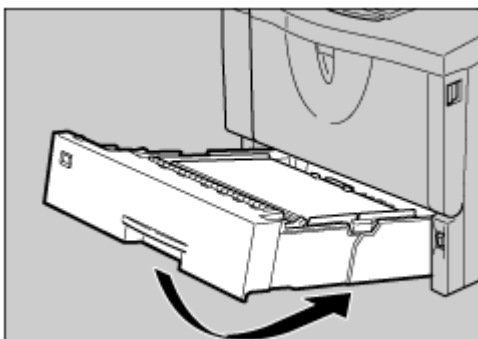

Z603150E

- 7 Reinstall the optional duplex unit if it was removed.

 Reference

See [p.108 "Moving and Transporting the Printer"](#) , Appendix.

---

## Replacing the Fusing Unit

---

### CAUTION

- *The fusing unit becomes very hot. When installing the new fusing unit, turn off the printer and wait about an hour. After that, install the new fusing unit. Not waiting for the unit to cool down can result in a burn.*

---

### Replacing the fusing unit

---

- 1 Open the rear cover by pushing the two knobs.

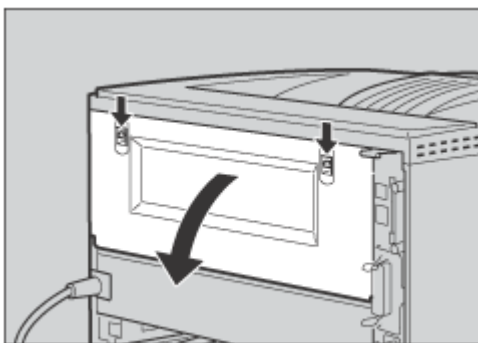

Z603210E

**2** Remove the rear cover in a horizontal direction.

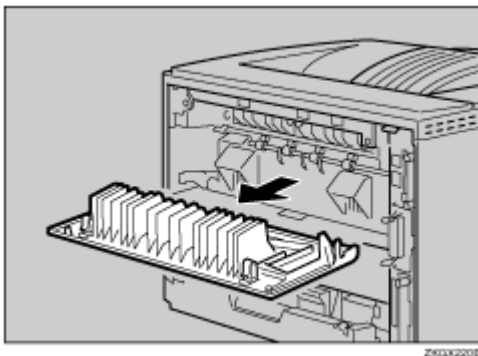

**3** Lift the lock levers of the fusing unit as shown in the illustration.

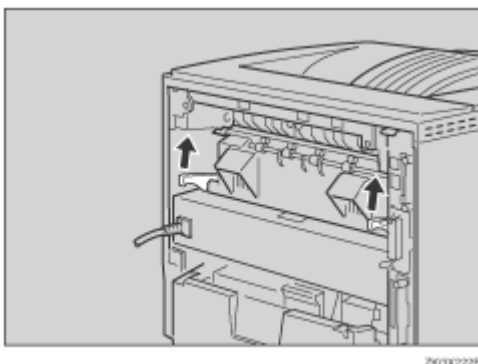

**4** Pull the fusing unit out.

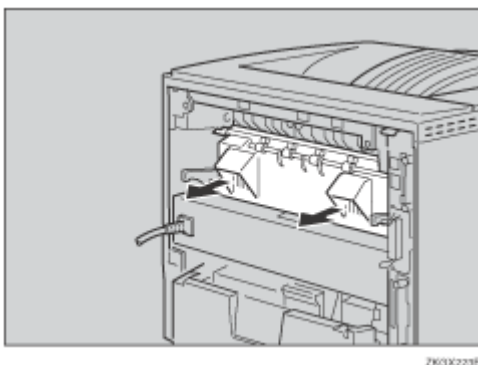

- 5** Pull out the pins on both sides of the new fusing unit.

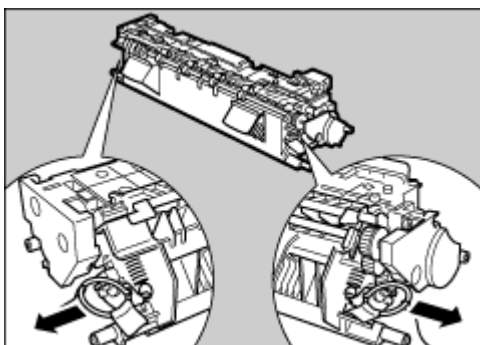

ZK09M10E

- 6** Replace the new fusing unit into the printer.

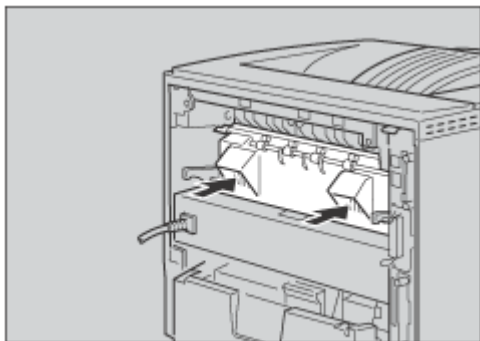

ZK03K224E

- 7** Push the lock levers of the fusing unit down until it clicks.

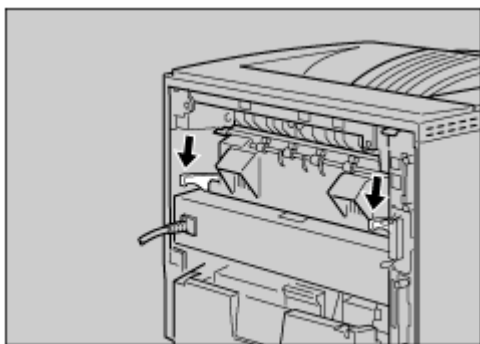

ZK03K225E

- 8** Insert the rear cover to the inside grooves on both sides of the printer in a horizontal direction.

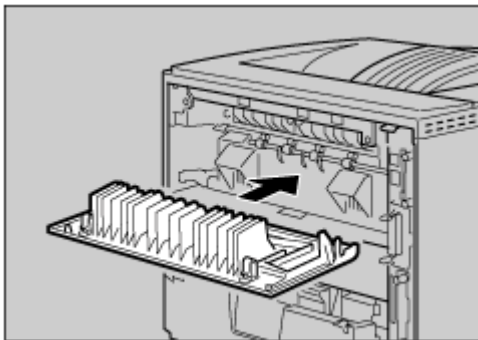

ZK3X211E

- 9** Close the rear cover.

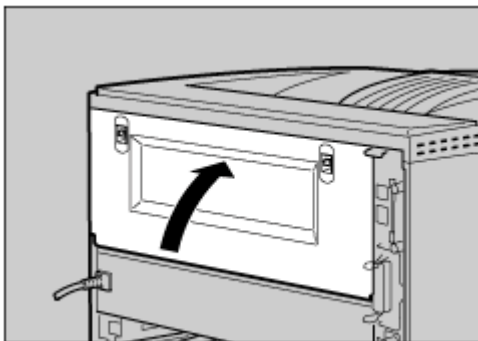

ZK3X211E

- 10** Print a configuration page to confirm that the printer works properly.

 **Reference**

For more information about printing the configuration page, see “Test Printing”, Setup Guide.



---

Replacing the fusing unit with the duplex unit attached

---

- 1** Push down the lever on the right side of the duplex unit (①), and then pull it out until it stops (②).

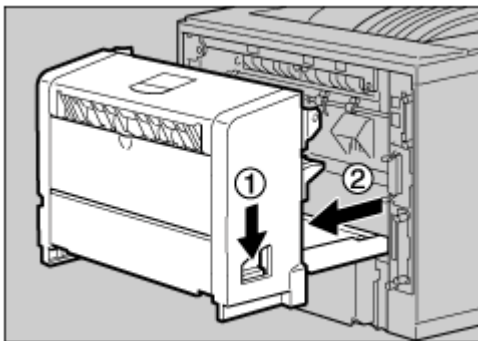

ZK03K221E

- 2** Lift the lock levers of the fusing unit as shown in the illustration.

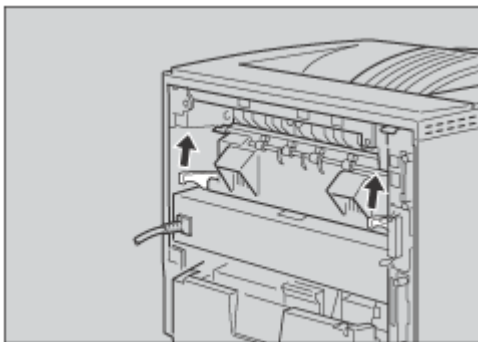

ZK03K222E

- 3** Pull the fusing unit out.

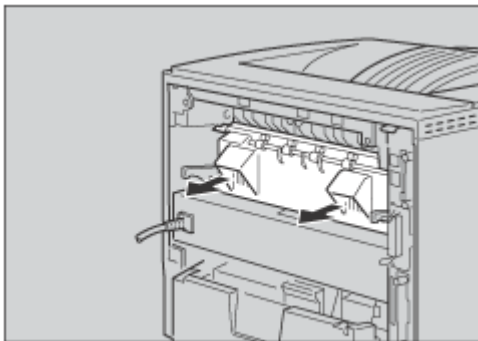

ZK03K223E

- 4** Pull out the pins on both sides of the new fusing unit.

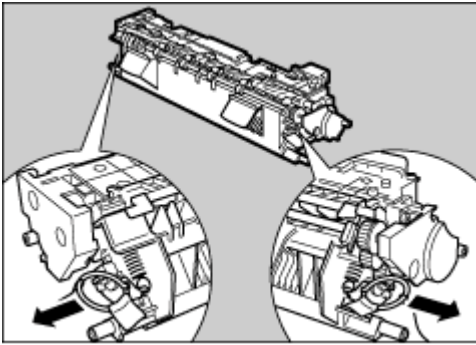

ZK09M10E

- 5** Replace the new fusing unit into the printer.

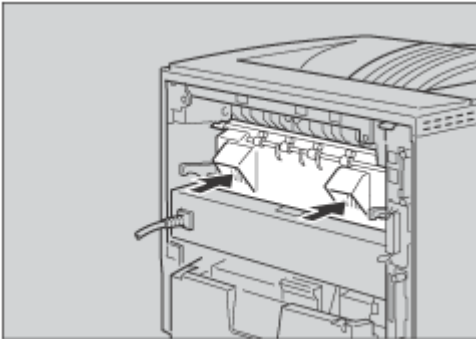

ZK03K224E

- 6** Push the lock levers of the fusing unit down until it clicks.

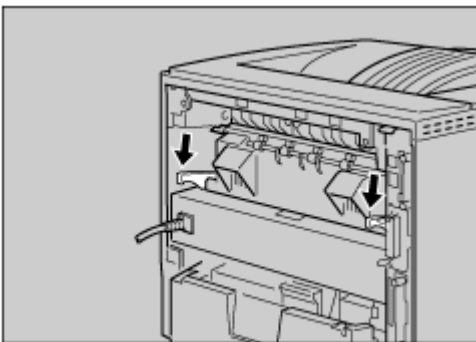

ZK03K225E

- 7** Align the power cable with the groove of the left slide of the duplex unit, and then insert the duplex unit into back of the printer aligning the rails inside of the printer until it is connected.

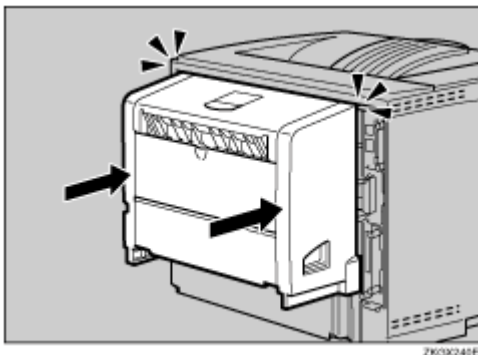

- 8** Print a configuration page to confirm that the printer works properly.

 Reference

For more information about printing the configuration page, see “Test Printing”, Setup Guide.

## Cautions to Take When Cleaning

### **WARNING**

- ***Do not remove any covers or screws other than those specified in this manual. Some parts of the machine are at a high voltage and could give you an electric shock. Also, if the machine has laser systems, direct (or indirect) reflected eye contact with the laser beam may cause serious eye damage. When the machine needs to be checked, adjusted, or repaired, contact your service representative.***
- ***Do not take apart or attempt any modifications to this machine. There is a risk of fire, electric shock, explosion or loss of sight. If the machine has laser systems, there is a risk of serious eye damage.***

### **CAUTION**

- *When removing misfed paper, do not touch the fusing unit because it could be very hot.*

Clean the printer periodically to maintain fine printing.

Dry wipe the exterior with a soft cloth. If dry wiping is not enough, wipe with a soft, wet cloth that is wrung out well. If you still cannot remove the stain or grime, use a neutral detergent, and then wipe over with a well-wrung wet cloth, dry wipe, and let it dry.

### **Important**

- To avoid deformation, discoloration, or cracking, do not use volatile chemicals, such as benzine and thinner, or spray insecticide on the printer.
- If there is dust or grime inside the printer, wipe with a clean, dry cloth.
- You must disconnect the plug from the wall outlet at least once a year. Clean away any dust and grime from the plug and outlet before reconnecting. Accumulated dust and grime pose a fire hazard.

## Cleaning the Friction Pad

If the friction pad is dirty, a multi-feed or a misfeed might occur. In this case, clean the pad as follows:

- 1** Lift the paper tray slightly, and then pull it out until it stops. Lift the front side of the tray, and then pull it out of the printer.

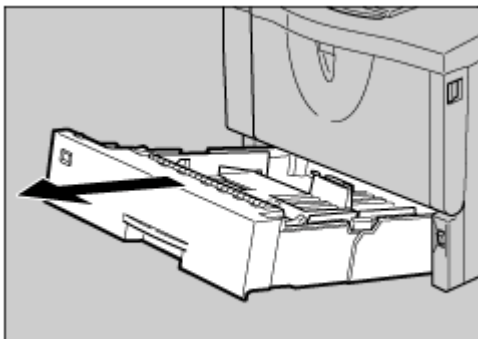

Z63Y143E

- 2** Place the tray on a flat surface. When there is paper in the tray, remove paper.

- 3** Wipe the brown part of the friction pad with a soft damp cloth. Then, wipe it with a dry cloth to remove the water.

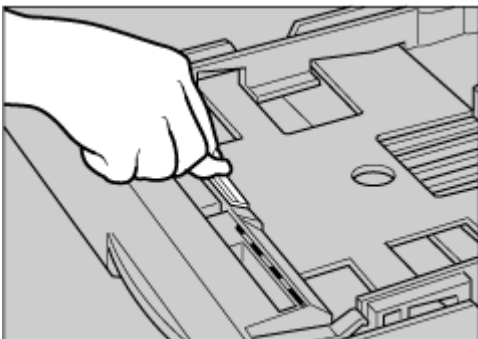

T50Y250E

**★ Important**

- Do not use chemical cleaner or organic solvent such as thinner or benzene.

- 4** Load paper into the paper tray with the print side up. Carefully slide the paper tray into the printer until it stops.

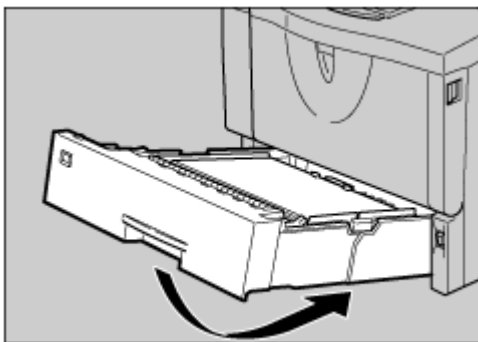

Z63Y150E

**★ Important**

- Do not slide the paper tray in with force. If you do, the front and side guides might move.

**↓ Note**

- If misfeeds or multi-feeds of paper occur after cleaning the friction pad, contact your sales or service representative.
- Follow the same procedure to clean the friction pad of the optional paper feed unit and the envelope feeder unit.

# Cleaning the Paper Feed Roller

If the paper feed roller is dirty, a misfeed might occur. In this case, clean the roller as follows:

## **⚠ CAUTION**

- *When lifting the printer, use the grips on both sides of the printer, otherwise the printer might fall and cause personal injury.*
- *When you move the printer, unplug the power cord from the wall outlet to avoid a fire or an electric shock.*
- *When you pull out the plug from the socket, grip the plug to avoid damaging the cord and causing a fire or an electric shock.*

## **★ Important**

- ❑ The following are examples of cleaning the paper feed roller on the paper tray.
- ❑ You can clean the paper feed roller on the optional paper feed unit by following the procedures below. The paper feed roller on the optional paper feed unit differs from the one on the paper tray. Confirm the type of paper feed roller you are installing.

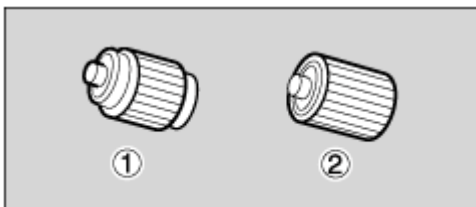

- ① For the paper tray
- ② For the paper feed unit

- 1** Turn off the power.
- 2** Pull out the plug from the socket. Remove all the cables from the printer.

- 3** Lift the paper tray slightly, and then pull it out until it stops. Lift the front side of the tray, and then pull it out of the printer.

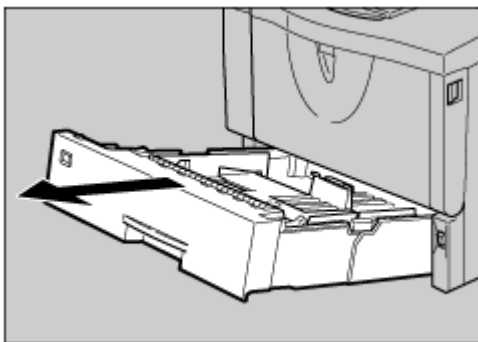

ZK3Y140E

- 4** Move the printer to the edge of a stable table or desk.

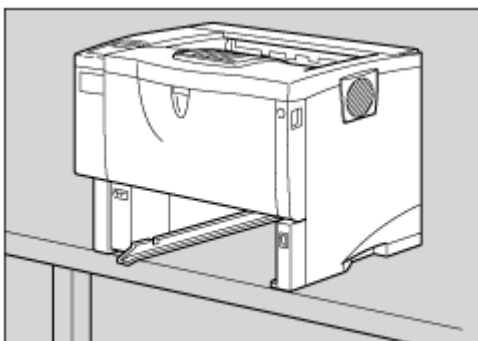

ZK3Y140E

**★ Important**

- Do not put the printer on an unstable or tilted surface.
- If the printer is equipped with the optional paper feed unit, do not move the printer and unit together as they are not securely attached.
- When lifting the printer, confirm that the optional paper feed unit is not attached to the printer.



- 5** Slide the green lock lever to the left (①), so that the paper feed roller can be released (②).

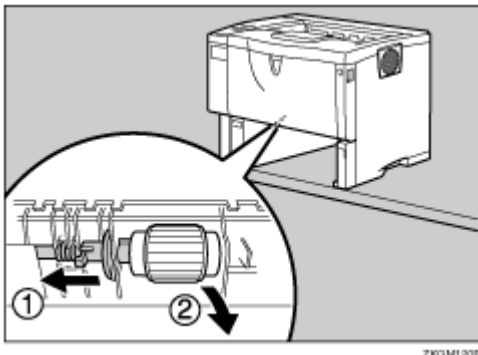

- 6** Wipe the rubber part of the roller with a soft damp cloth. Then, wipe it with a dry cloth to remove the water.

**★ Important**

- Do not use chemical cleaner or organic solvent such as thinner or benzene.

- 7** While sliding the green lock lever to the left (①), set the paper feed roller to its original position (②). Then, return the green lock lever to its original position (③).

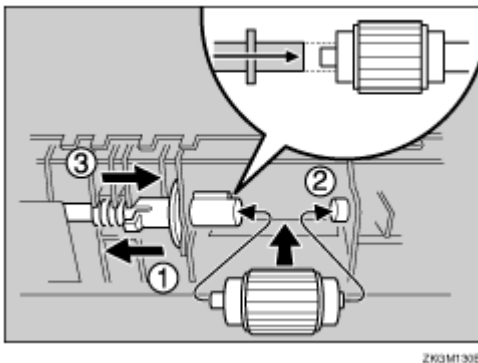

**↓ Note**

- Check the green lock lever secures the roller correctly by making sure the new roller rotates smoothly.

- 8** Move the printer to the place where it was placed. Carefully slide the paper tray into the printer until it stops.

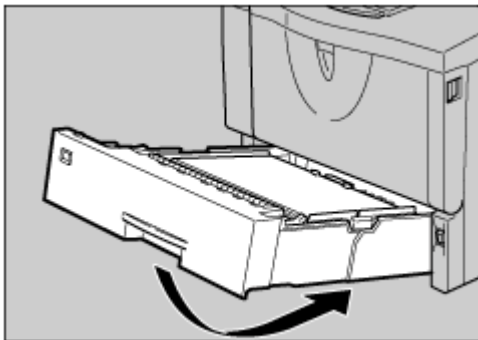

Z63Y150E

**★ Important**

- Do not slide the paper tray in with force. If you do, the front and side guides might move.

**↓ Note**

- Follow the same procedure to clean the paper feed roller of the optional paper feed Unit.

## Cleaning the Registration Roller

If the registration roller is dirty, a misfeed might occur. In this case, clean the roller as follows:

### **⚠ WARNING**

- ***Be sure to turn off the power and wait for about 30 minutes before cleaning the registration roller. Not waiting for the printer to cool down can result in a burn.***

### **⚠ CAUTION**

- ***The inside of this printer becomes very hot. Do not touch parts labelled “⚠” (indicating a hot surface). Touching these parts will result in burns.***

Clean the registration roller if dots (caused by specks of paper stuck to the roller) appear on printed OHP transparencies.

- 1** Turn off the power, and then unplug the power cable.
- 2** Open the front cover by pushing the front cover release button.

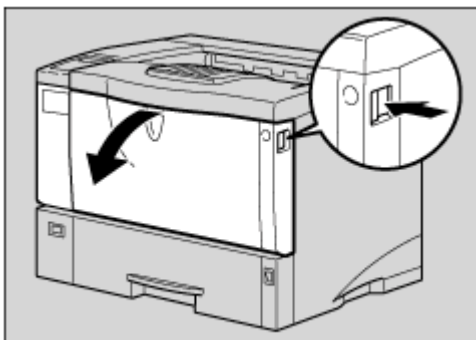

- 3** Pull the toner cartridge out of the printer by holding the grips of the cartridge.

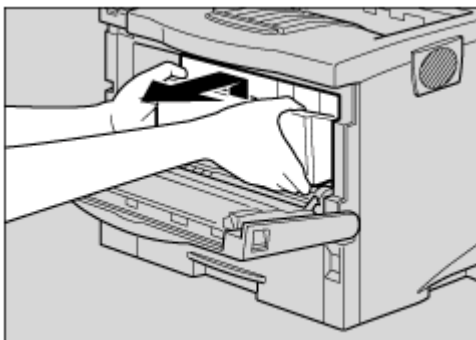

### **↓ Note**

- Do not hold the toner cartridge upside down or stand it vertically.

- Do not put the toner cartridge on an unstable or tilted surface.

**4** Wipe around the metallic registration roller by turning with a soft damp cloth.

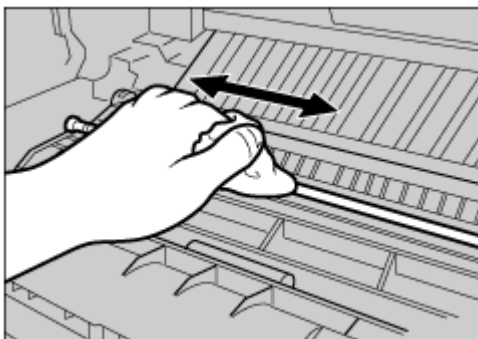

ZK036461E

**★ Important**

- Do not use chemical cleaner or organic solvent such as thinner or benzene.

**5** Hold the grips of the toner cartridge, and then insert it into the printer until it stops.

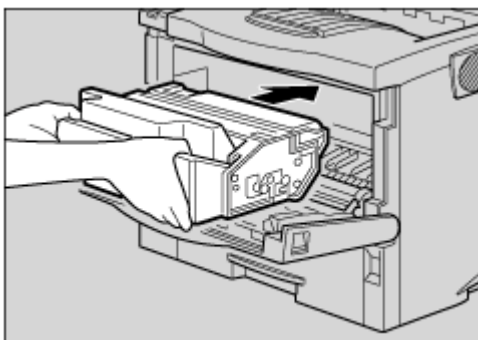

M504 475

**6** Lower the toner cartridge when it touches the back.

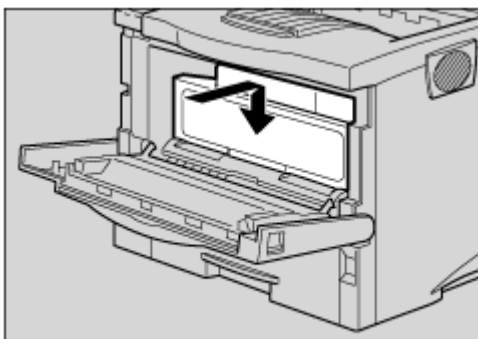

M504 446

**7** Close the front cover by pressing the left and right side indentations.

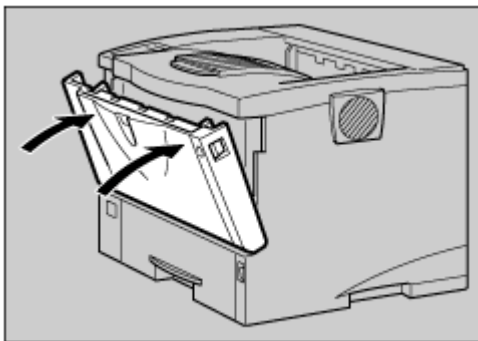

ZKGH130E

**★ Important**

- Carefully close the front cover. If you cannot close the cover easily, pull the toner cartridge out of the printer and insert it again. After that, close the front cover again.

# Adjusting the Image Density

You can adjust the image density when the print side of the page is a shaded or print image is too light.

## ★ Important

- ❑ Extreme settings may create printouts that appear dirty.
- ❑ Image density settings should be made from the application or the printer driver whenever possible.

**1** Press the [Menu] key.

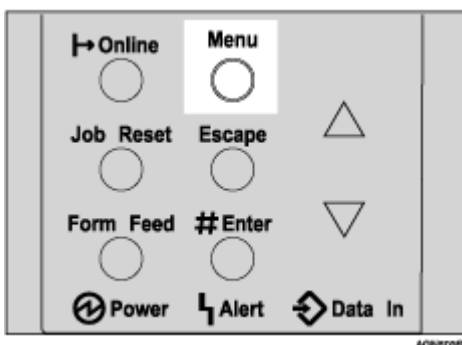

The [Menu] screen appears on the display.

**2** Press the [▲] or [▼] key to display [Maintenance], and then press the [# Enter] key .

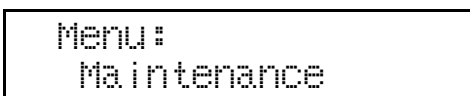

The maintenance menu appears.

**3** Check [Image Density] is displayed, and then press the [# Enter] key.

**4** Press the [▲] or [▼] key to set the image density value.

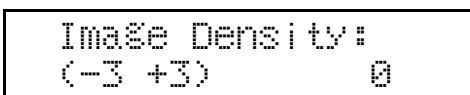

## ↓ Note

- ❑ To maintain a darker image under high volume printing conditions, we highly recommended that you select 3 from the control panel.
- ❑ You can adjust the image density in seven steps from -3 to +3. Increasing the value makes the printouts darker and decreasing the value makes the printouts lighter.

**5** Press the [# Enter] key .

Return to the maintenance menu.

**6** Press the **[Online]** key.

The initial screen appears.

## Adjusting Tray Registration

You can adjust the registration of each tray. The vertical adjustment is used for all trays. Normally, you need not update the registration. But when the optional paper feed unit or the duplex unit is installed, updating is useful in some cases. The following procedure describes how to adjust tray 2. The same procedure applies to other trays as well.

- 1** Press the [Menu] key.

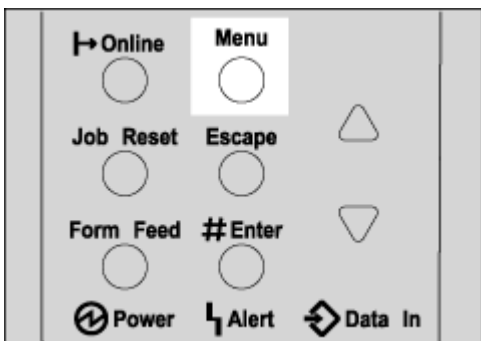

The [Menu] screen appears on the display.

- 2** Press the [▲] or [▼] key to display [Maintenance], and then press the [# Enter] key .

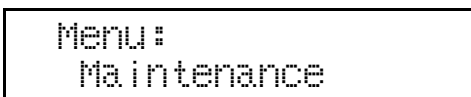

The maintenance menu appears.

- 3** Press the [▲] or [▼] key to display [Registration], and then press the [# Enter] key .

The registration menu appears.

- 4** Print the test sheet to preview the settings. Confirm that [Prt. Test Sheet] is displayed, and then press the [# Enter] key.

A screen prompting you to select the tray to be adjusted appears.

- 5** Press the [▲] or [▼] key to select the tray to adjust, and then press the [# Enter] key.

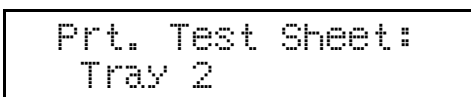

The test sheet prints out. The display returns to the registration menu. Press the [Escape] key.



- 6** Confirm the position of the image on the test sheet, and then adjust the registration value.

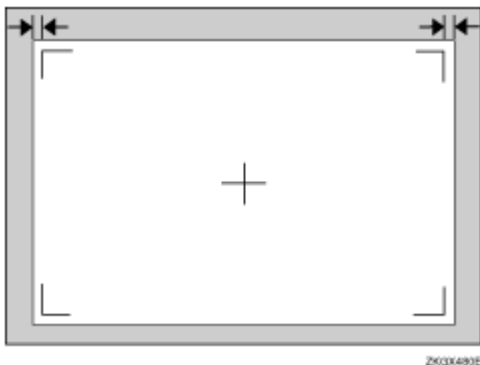

- 7** Press the [▲] or [▼] key to display [Adjustment], and then press the [# Enter] key.

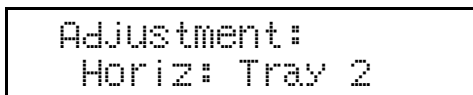

- 8** Press the [▲] or [▼] key to set the registration value (mm).

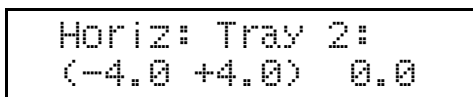

- 9** Press the [▲] or [▼] key to set the digit of the registration value (mm).  
Increase the value to shift the print area in the positive direction, and decrease to shift in the negative direction.

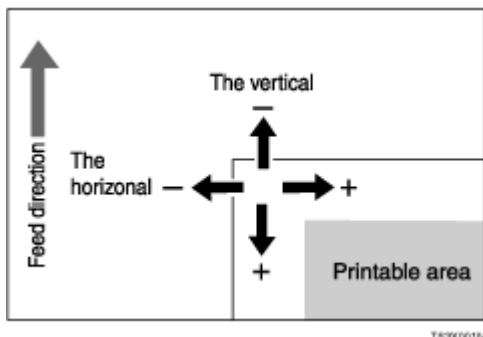

**Note**

- Pressing the [▲] or [▼] key makes the value increase or decrease by 1.0 mm steps.

- 10** Press the [# Enter] key.

- 11** Press the [Escape] key.

The display returns to the print area **[Adjustment]** menu.



**12** Print the test sheet to confirm the adjustment result.

**13** Press the **[Online]** key.

The initial screen appears.

# Error & Status Messages on the Control Panel

This section explains what the messages that appear on the control panel mean and what to do when a particular message appears.

## ❖ Messages (in alphabetical order)

Messages/Second messages	Description	Solution
Call Service: EC Power Off On / If Error Reoccur Call Service	A communication error sent from the engine to the controller has occurred in the printer.	Turn the power off, and then on. If the message appears again, call your sales or service representative.
Cannot check Signal in Ad hoc	An attempt to check the radio signal was made while the communication mode was set to <b>[802.11 Ad hoc]</b> in the interface settings.	To check the radio signal, select Infrastructure in the communication mode settings.
Change Setting Tray # / Paper Size: Paper Type:	The paper size and type setting in the tray differs from that of actual paper size and type in the tray. #: tray number	Load paper of the selected size in the tray, and then change the paper size setting with the control panel. Or, press <b>[Form Feed]</b> , and then select the tray using the control panel. Or, press <b>[Job Reset]</b> to cancel the print job. You can make to setting to print disregarding the error message.
Close Duplex Unit Cover	The cover of the optional duplex unit is open.	Close the cover of the optional Duplex Unit.
Close Front Cover	The front cover is open.	Close the front cover by pressing the left and right side indentations.
Close Rear/Paper Exit Cover	The paper exit cover or the rear cover is open.	Close the paper exit cover or the rear cover.
DHCP assigned Cannot change	An attempt to change the IP address, subnet mask or gateway address was made while DHCP was set to <b>[On]</b> .	Make the change after setting DHCP to <b>[Off]</b> .
Energy Save Mode	The printer is in Energy Saver mode.	No action required.
Error: Enter 5 or 13 characters	An ID with an invalid number of digits was entered for the WEP key.	Enter the correct number of digits for the WEP key.

Messages/Second messages	Description	Solution
Error: Enter 10 or 26 characters	An ID with an invalid number of digits was entered for the WEP key.	Enter the correct number of digits for the WEP key.
Hardware Problem Ethernet	An error has occurred in the optional Network Interface Board.	Turn the power off, and then on. If the message appears again, call your sales or service representative.
Hardware Problem HDD	An error has occurred in the optional Hard Disk Drive.	Turn the power off, and then on, If the message appears again, call your sales or service representative.
		Turn off the power. Replace the Hard Disk Drive and turn on the power. See "Attaching Hard Disk Drive Type 2600 ", Setup Guide.
		Turn off the power. Remove the Hard Disk Drive and turn on the power. <div data-bbox="788 788 934 819" style="border: 1px solid blue; padding: 2px; margin: 5px 0;">  Note         </div> <input type="checkbox"/> If the Hard Disk Drive is not installed, you cannot send the sample print job, locked print job and download the font to Hard Disk Drive using the PS Utility for Mac.

Messages/Second messages	Description	Solution
<p>Hardware Problem IEEE1394</p>	<p>The printer identified an IEEE 1394 interface board error.</p>	<p>Turn the power off, and then on. Remove and re-install the IEEE 1394 interface board correctly.</p> <ol style="list-style-type: none"> <li>① Check the IEEE 1394 interface board is correctly attached to the computer.</li> <li>② Check the IEEE 1394 interface cable is securely connected.</li> <li>③ Unplug the IEEE 1394 interface cable which is connected to the printer.</li> <li>④ Restart the computer. If the message appears even after executing above operation, proceed to the following steps.</li> <li>⑤ Execute the utility tool for IEEE 1394 interface board that is stored in the following path in the CD-ROM labeled "Printer Drivers and Utilities": UTILITY\ 1394</li> </ol> <p><b>★ Important</b></p> <p><input type="checkbox"/> For details about using the utility tool for IEEE 1394, see the README file in the same directory in the CD-ROM. If the message appears again, contact your sales or service representative.</p> <p>See "Attaching 1394 Interface Unit Type 4510", Setup Guide.</p>
<p>Hardware Problem Option RAM</p>	<p>The printer identified an optional RAM error.</p>	<p>Turn the power off, and then on. Remove and re-install the optional RAM. If the message appears again, contact your sales or service representative. See "Attaching Memory Unit Type C 256MB (SDRAM Module)", Setup Guide.</p> <p>Turn off the power, remove the Memory Unit, and then turn on the power.</p> <p><b>↓ Note</b></p> <ul style="list-style-type: none"> <li><input type="checkbox"/> If you remove the Memory Unit, you must set up the option with the printer driver.</li> <li><input type="checkbox"/> In this case, you might not be able to print complex print jobs.</li> </ul>

Messages/Second messages	Description	Solution
Hardware Problem Parallel I/F	There is a problem with the parallel interface.	If you use the parallel I/F, replace the interface cable that caused the error. If the message appears again, contact your sales or service representative.
Hardware Problem USB	There is a problem related to the Universal Serial Bus Connection and Hardware.	Turn the power off, and then on. If the message appears again, contact your sales or service representative.
Hardware Problem Wireless Board	An error was detected in the IEEE 802.11b interface unit or the Bluetooth interface unit.	Turn the power off, and then on. Remove and re-install the IEEE 802.11b interface unit or the Bluetooth interface unit correctly. If the message appears again, contact your sales or service representative. See "Attaching 802.11b Interface Unit Type F" or "Attaching Bluetooth Interface Unit Type C", Setup Guide.
Hardware Problem Wireless Card	The IEEE 802.11b interface unit or the Bluetooth interface unit could not be detected when the power was turned on. The IEEE 802.11b interface card or the Bluetooth interface card was removed after the power was turned on. An error was detected in the IEEE 802.11b interface card or the Bluetooth interface card.	Turn the power off, and then on. Remove and re-install the IEEE 802.11b interface unit or the Bluetooth interface unit correctly. If the message appears again, contact your sales or service representative. See "Attaching 802.11b Interface Unit Type F" or "Attaching Bluetooth Interface Unit Type C", Setup Guide.
HDD Full	The maximum HDD area size for form/font has been exceeded.	Delete the disused form/font types.
	The optional Hard Disk Drive is full. The sample print job or locked print job to be sent from the computer is too large to store.	Delete any unnecessary stored files.
HDD not Installed	You cannot print the sample print and the locked print jobs, because the optional Hard Disk Drive is not installed.	Install the Hard Disk Drive. See "Attaching Hard Disk Drive Type 2600", Setup Guide.
Hex Dump Mode	The printer is in Hex Dump Mode.	No action required.
Invalid Data Power Off On	The printer has received irregular data.	Turn the power off, and then on. If the message appears again, contact your sales or service representative.

Messages/Second messages	Description	Solution
Invalid Password Try again	The password entered using the control panel is not correct.	Enter the correct password using the control panel.
Load Correct Size Paper / Press # to continue	The paper size setting on the tray differs from that of actual paper size in the tray.	Load { paper size } paper of the selected feed direction and paper size into the tray. Printing will not automatically resume if the paper size and direction setting is incorrect. Make sure that the paper feed directions set in the printer driver and on the control panel are the same. There are two methods to resume printing. ① Use the control panel to set the correct paper size and direction of the paper in tray. Then Press the <b>【# Enter】</b> key . ② Press <b>【Form Feed】</b> and select the tray with the control panel.
Load Paper or Form Feed / Paper Size: Paper Type:	The paper type and size settings for this tray do not match the size and type of paper actually loaded.	Load paper into the tray indicated, then press the <b>【# Enter】</b> key to resume printing. Or press <b>【Form Feed】</b> and select the tray that holds a different type of paper. To cancel printing, press <b>【Job Reset】</b> . Then Press the <b>【# Enter】</b> key .
Load Paper:Tray # or Form Feed / Paper Size: Paper Type:	There is no paper left in this tray. #: tray number	Load paper into the tray indicated.
Menu Protected Cannot change	The menu is protected and the settings cannot be changed.	Wait for two seconds until the previous display appears.
No Files exist	There are no files available for the sample print job or the locked print job.	Wait for two seconds until the previous display appears.
Offline	The printer is offline and cannot print data.	Press <b>【Online】</b> key.
P= XX I= XXXXXXXX Power Off On / If Error Reoccur Call Service	A controller error. The SC number indicates the problem.	Turn the power off, and then on. If the message appears again, call your sales or service representative.
Processing...	Print data is being processed.	Wait a while.
RC Gate connection error	Cannot communicate with RC Gate.	Check the device or the RC Gate network connection.

Messages/Second messages	Description	Solution
Ready	The default ready message. The printer is ready to use.	No action required.
Remove Misfeed Duplex Unit / Open Duplex Unit Cover	There is misfeed in the Duplex Unit.	Remove the misfed paper. See <a href="#">p.104 "When "Remove Misfeed Duplex Unit" Appears"</a> .
Remove Misfeed Internal Path / Open Front Cover	There is a misfeed in the printer.	Remove the misfed paper. See <a href="#">p.96 "When "Remove Misfeed Internal Path" Appears"</a> .
Remove Misfeed Paper Exit Cover / Open Paper Exit Cover	There is a misfeed in the paper exit cover.	Remove the misfed paper. See <a href="#">p.99 "When "Remove Misfeed Paper Exit Cover" Appears"</a> .
Remove Misfeed Paper Tray / Pull out Tray	Paper is jammed in the specified input paper tray.	Remove the misfed paper. See <a href="#">p.94 "When "Remove Misfeed Paper Tray" Appears"</a> .
Remove Paper Standard Tray	The standard tray is full, and the print job is suspended.	Remove paper from the standard tray, and the print job will be resumed automatically.
Replace Maintenance Kit	It is time to replace the maintenance kit (friction pad, paper feed roller, transfer roller and fusing Unit).	Replace the new maintenance kit. See <a href="#">p.44 "Replacing the Maintenance Kit"</a> .
Replace Toner Cartridge	The toner cartridge is not set correctly or toner is almost run out.	Set the toner cartridge correctly. See <a href="#">p.39 "Replacing the Toner Cartridge"</a> .
	The toner dust is full.	Prepare a new toner cartridge. If the image density gets too light, replace the toner cartridge with a new one. See <a href="#">p.39 "Replacing the Toner Cartridge"</a> .
Reset Duplex Unit correctly	A communication error sent from the system unit to the duplex unit.	Set the duplex unit correctly. If the problem persists, call your service provider.





Messages/Second messages	Description	Solution
Reset Toner Cartridge	The toner cartridge is not set correctly.	Set the toner cartridge correctly. See <a href="#">p.39 "Replacing the Toner Cartridge"</a> .
	The toner cartridge is not set installed.	If the cartridge is installed, close the front cover and turn the off power switch and then on. If the message appears again, contact your sales or service representative.
Reset Tray # or Form Feed	The indicated paper input tray is not set correctly, or not set. #: tray number	Set the indicated paper input tray correctly.
Resetting Job...	The print job is being reset.	Wait for a while.
ROM Update Waiting for Data	The printer is waiting for updated data.	Don't turn off the printer while it is waiting for data.
ROM Update Receiving Data	The printer is receiving updated data.	Don't turn off the printer while it is receiving data.
SC XXX-X Power Off On If Error Reoccur Call Service	An error has occurred.	Turn the power off, and then on. If the message appears again, contact your sales or service representative.
Supply order failed	Supply order has failed.	The use is required to reset the job.
SD authenticatn failed	Authentication for the SD card has failed.	Turn the power off, and then on. If the message appears again, contact your sales or service representative.
Setting change in process	A setting change is currently in process on the computer side.	The user must wait until the change is complete.
Setting changed Restart Printer	<b>[RAM Disk]</b> or <b>[Notify by E-mail]</b> setting has been changed.	Restart the printer so the new settings can take effect.
SSID not entered	This message appears if the SSID has not been entered.	Enter the SSID.
Toner is almost empty	The toner is almost run out.	Prepare a new toner cartridge. If the image density gets too light, replace the toner cartridge with a new one. See <a href="#">p.39 "Replacing the Toner Cartridge"</a> .
Update Mode Err. Power Off On	The printer has failed to start updating data.	Turn the power off, and then on to restart.
Waiting...	The printer is waiting for the next print job.	Wait a while.

Messages/Second messages	Description	Solution
Warming up...	The printer is warming up or toner is being supplied.	Wait until the panel display change the <b>[Ready]</b> .

# Printer Does Not Print

Possible Cause	Solutions
Is the power on ?	Confirm that the cable is securely plugged into the power outlet and the printer. Turn on the power.
Does the <b>Online</b> indicator stay on ?	If not, Press the <b>[Online]</b> key to light it.
Does the <b>Alert</b> indicator stay red ?	If so, check the error message on the display and take the required action.
Is paper loaded ?	Load paper into the paper tray or onto the bypass tray.
Can you print a configuration page ?	If you cannot print a configuration page, it probably indicates a printer malfunction. Contact your sales or service representative. See "Test Printing", Setup Guide.
Is the interface cable connected securely to the printer and the computer ?	Connect the interface cable securely. If it has a fastener, fasten it securely as well.
Are you using the correct interface cable ?	The type of interface cable you should use depends on the computer you use. Be sure to use the correct one. If the cable is damaged or worn, replace it with a new one.
Is the <b>Data In</b> indicator blinking or lit after starting the print job ?	If not blinking or lit, the data is not being sent to the printer.  ❖ <b>If the printer is connected to the computer using the interface cable</b> Check the port connection setting is correct. For details about checking the port connection, see <a href="#">p.84 "Checking the port connection"</a> .  ❖ <b>Network Connection</b> Contact your network administrator.
How is the signal strength when using the wireless LAN ?	❖ <b>Ad hoc Mode or 802.11 Ad hoc Mode</b> Either move to a location where the signal is good, or remove obstructions.  ❖ <b>Infrastructure Mode</b> Check the signal status from the <b>[Maintenance]</b> menu on the control panel. If the signal is poor, either move to a location where it is good, or remove obstructions.
How is the signal strength when using Bluetooth ?	Try the following: <ul style="list-style-type: none"> <li>• Check the Bluetooth interface unit is installed properly.</li> <li>• Check there are no obstructions between computer, printer and other devices.</li> <li>• Change the location of the computer.</li> <li>• Change the location of the printer.</li> </ul>

Possible Cause	Solutions
<p>When you use the optional Bluetooth interface unit.</p>	<p><b>SPP</b></p> <ol style="list-style-type: none"> <li>① Make sure the machine you want to use appears in the 3Com Bluetooth Connection Manager.</li> <li>② Make sure “Bluetooth Serial Client (COMx)” appears under Client Ports in the 3Com Bluetooth Connection Manager.</li> <li>③ Restart computer, this printer, and the other devices.</li> <li>④ Make sure no IEEE 802.11b (wireless LAN) or other Bluetooth devices are in use.</li> </ol> <p> <b>Note</b></p> <ul style="list-style-type: none"> <li><input type="checkbox"/> Interference may occur with the IEEE 802.11b wireless LAN interface board. Such interference may affect the transmission speed and other functions.</li> </ul> <ol style="list-style-type: none"> <li>⑤ Transmissions between computers, other devices, and this printer can be blocked by obstructions. Move this printer, computers, and other devices, if necessary.</li> </ol> <p><b>HCRP, BIP</b></p> <ol style="list-style-type: none"> <li>① Restart the computer, this printer, and other devices.</li> <li>② Make sure no IEEE 802.11b (wireless LAN) or other Bluetooth devices are in use.</li> </ol> <p> <b>Note</b></p> <ul style="list-style-type: none"> <li><input type="checkbox"/> Interference may occur with the IEEE 802.11b wireless LAN interface board. Such interference may affect the transmission speed and other functions.</li> </ul> <ol style="list-style-type: none"> <li>③ Transmissions between computers, other devices, and this printer can be blocked by obstructions. Move this printer, computers, other devices, if necessary.</li> </ol>

If printing still does not start, contact your sales or service representative. Consult with the store where the printer was purchased for information about the location of sales or service representatives.

## Checking the port connection

When the printer is directly connected via the PC cable and the data-in indicator does not flash or light up, the method of checking the port connection is as follows.

- For a parallel port connection, port LPT 1 or LPT 2 should be set.
- For a USB port connection, port USB00 (n) <sup>\*1</sup> should be set.
- For a IEEE 1394 (SCSI print) port connection, port 1394\_00(n) <sup>\*1</sup> should be set.

\*1 (n) is the number of printers connected.

---

### Windows 95/98/Me

---

- 1** Click [Start], point to [Settings] and then click [Printers].
  - 2** Click to select the icon of the printer. Next, on the [File] menu, click [Properties].
  - 3** Click the [Details] tab.
  - 4** Check the [Print to the following port] box to confirm that the correct port is selected.
- 

---

### Windows 2000

---

- 1** Click [Start], point to [Settings] and then click [Printers].
  - 2** Click to select the icon of the printer. Next, on the [File] menu, click [Properties].
  - 3** Click the [Port] tab.
  - 4** Check the [Print to the following port] box to confirm that the correct port is selected.
- 

---

### Windows XP Professional, Windows Server 2003

---

- 1** Select the [Printers and Faxes] window from [Start] on the taskbar.
  - 2** Click to select the icon of the printer. Next, on the [File] menu, click [Properties].
  - 3** Click the [Port] tab.
  - 4** Check the [Print to the following port(s).] box to confirm that the correct port is selected.
- 

---

### Windows XP Home Edition

---

- 1** Select the [Control Panel] window from [Start] on the taskbar.
  - 2** Click [Printers and Other Hardware].
  - 3** Click [Printers and Faxes].
  - 4** Click to select the icon of the printer. Next, on the [File] menu, click [Properties].
-

**5** Click the [Port] tab.

**6** Check the [Print to the following port(s).] box to confirm that the correct port is selected.

---

Windows NT 4.0

---

**1** Click [Start], point to [Settings] and then click [Printers].



**2** Click to select the icon of the printer. After that, on the [File] menu, click [Properties].

**3** Click the [Port] tab.

**4** Check the [Print to the following port] box to confirm that the correct port is selected.

# Other Printing Problems

Status	Possible Causes, Descriptions, and Solutions
<p>The print side of the page is a hazy gray.</p>	<p>Adjust the image density. See <a href="#">p.70 "Adjusting the Image Density"</a>.</p>
	<p>If paper is curled, correct it.</p>
	<p>If you continuously print data that contains extremely small amount of words or images in the printable area, the printed side of the page could be a hazy gray. Adjust the image density. See <a href="#">p.70 "Adjusting the Image Density"</a>.</p>
	<p>Shaking the toner cartridge after pulling out the toner seal can cause dirt on paper surfaces, toner spillage, or printer failure. If you have accidentally shaken the toner cartridge, print some pages (about 50 pages) until the dirt disappears.</p>
<p>The paper's reverse side is dirty.</p>	<p>Paper loaded in the Paper Tray or Paper Feed Unit may not match the paper size dial setting. Set the paper size dial so it matches the size and feed direction of the paper in the tray. See <a href="#">p.16 "Loading Paper in Tray 1 and the optional paper feed unit"</a>.</p>
	<p>The size and feed direction of paper in the Bypass Tray may not match the control panel settings. Check the control panel settings so they match the size and feed direction of the paper in the tray. See <a href="#">p.25 "Loading Paper in the Bypass Tray"</a>.</p>
	<p>The next sheet of paper printed may have a dirtied reverse side if the data size is larger than the paper being printed onto, such as A4 data onto B5 paper.</p>
<p>Image quality varies when printing on thick paper or on OHP transparencies.</p>	<p>Switch to Thick Paper mode.</p> <ul style="list-style-type: none"> <li>• When toner is not fused enough, set it to "On".</li> <li>• When the image is blurred, set it to "----".</li> </ul> <p>See "Making Printer Setting Using Control panel", Software Guide.</p>
<p>Some parts of the print image are not clear.</p>	<p>Make the image density darker. See <a href="#">p.70 "Adjusting the Image Density"</a>.</p>
	<p>If Toner Saving mode is selected using the control panel, the whole image gets lighter.</p>
<p>The print image is not clear.</p>	<p>Due to a sudden change in temperature, condensation might appear inside the printer, reducing print quality. If this occurs, when you move the printer from a cold room to a warmer room, do not use the printer until it acclimatizes to the temperature.</p>

Status	Possible Causes, Descriptions, and Solutions
Nothing is printed on the paper.	<p>Check if the tape of the toner cartridge is completely removed. Be sure to remove the tape completely when replacing the toner cartridge.</p> <p>See <a href="#">p.39 “Replacing the Toner Cartridge”</a>.</p> <p> <b>Note</b></p> <p><input type="checkbox"/> If the power switch is turned on with the tape still attached to the toner cartridge, the printer might be damaged.</p>
Multiple pages are fed through the printer at once.	<p>Clean the friction pad if it is dirty.</p> <p>See <a href="#">p.61 “Cleaning the Friction Pad”</a>.</p> <p>If the problem persists, set the paper the other way up, and then print it.</p> <p> <b>Note</b></p> <p><input type="checkbox"/> This method cannot be used with the adhesive label paper.</p> <p>Remove all paper from the tray and fan it gently to get air between the sheets. After that, load it back into the tray.</p>
The image is printed on the reverse side of the paper.	<p>Set the paper the other way up.</p>
Paper misfeeds occur frequently.	<p>Check the paper size settings. The size set with the paper size dial might be different from the actual paper size. Make the correct dial setting.</p> <p>See <a href="#">p.16 “Loading Paper”</a>.</p> <p>Use the recommended paper. Avoid using curled, folded, wrinkled, perforated or glossy paper.</p> <p>See <a href="#">p.10 “Paper Recommendations”</a>.</p> <p>Clean the paper feed roller, friction pad and/or registration roller, if they are dirty.</p> <p>See <a href="#">p.61 “Cleaning the Friction Pad”</a>, <a href="#">p.63 “Cleaning the Paper Feed Roller”</a>, or <a href="#">p.67 “Cleaning the Registration Roller”</a>.</p> <p>If the problem persists, set the paper the other way up, and then print it.</p> <p> <b>Note</b></p> <p><input type="checkbox"/> This method cannot be used with the adhesive label paper.</p> <p>Thin paper, if printed on both sides, may curl up at the corners and get wrinkled and clogged. Select <b>[Curl Prevention] [On]</b> from the <b>[Maintenance]</b> menu.</p>
The control panel error message stays on after removing the misfed paper.	<p>Open the front cover of the printer and then close it.</p> <p>See <a href="#">p.93 “Removing Misfed Paper”</a>.</p>







Status	Possible Causes, Descriptions, and Solutions
<p>Output are not delivered to the selected tray you require.</p>	<p>Check the paper size settings. The size selected with the paper size dial might be different from the actual paper size. Make the correct dial setting.</p> <p>See <a href="#">p.16 “Loading Paper in Tray 1 and the optional paper feed unit”</a>.</p>
	<p>When using the Bypass Tray, set the paper size using the control panel.</p> <p>See <a href="#">p.25 “Loading Paper in the Bypass Tray”</a>.</p>
	<p>When you are using a Windows operating system, the printer driver settings override those set using the control panel. Set the desired output tray using the printer driver.</p> <p>See the driver's online Help file.</p>
<p>The printed image is different from the image on the computer.</p>	<p>When you use some functions, such as enlargement and reduction, the layout of the image might be different from that shown in the computer display.</p>
<p>It takes too much time to resume printing.</p>	<p>The data is so large or complex that it takes time to process it. If the <b>Data In</b> indicator is blinking, the data processing is being done. Just wait until it resumes.</p>
	<p>Changing the paper feed direction may sometimes reduce the time to resume printing.</p>
<p>The image is printed in the wrong orientation.</p>	<p>Set the correct orientation under the “PCL Menu” with the control panel. See “Making Printer Settings Using the Control Panel”, Software Guide.</p>
	<p>Confirm that the setting of orientation has been set in the application you use.</p>
	<p>Set the correct paper size and feed direction that matches tray settings on the RPCS printer driver.</p>
<p>Part of the image cannot be printed.</p>	<p>A paper size which is smaller than that selected in the application is used for printing. Load the correct size of paper.</p>
<p>Network configurations you have made do not become effective.</p>	<p>Print a configuration page and check the network settings.</p>
<p>A portion of the image is not printed or an error occurred in the PostScript printer driver when printing with PCL or the PostScript printer driver.</p>	<p>You can print using the procedure below.</p> <ul style="list-style-type: none"> <li>• Set <b>[Memory Usage]</b> in the System Menu to <b>[Font Priority]</b> on the control panel.</li> </ul> <p> <b>Important</b></p> <ul style="list-style-type: none"> <li><input type="checkbox"/> Return the setting to <b>[Font Priority]</b> after you have finished printing. If the setting is left as <b>[Font Priority]</b>, continuous printing speed may decrease, two-sided printing may be canceled or a job reset may occur during continuous printing.</li> </ul> <ul style="list-style-type: none"> <li>• If the entire image is not printed out properly even after changing the above setting, add an additional memory unit.</li> </ul>

Status	Possible Causes, Descriptions, and Solutions
<p>The paper size appears on the control panel and printing is not performed with PDF Direct Print.</p>	<p>When using PDF Direct Print, printout requires paper set within the PDF file. When a message indicating a paper size appears, either place the indicated size in the paper tray, or perform Form Feed.</p> <p>Also, if <b>[Sub Paper Size]</b> in the System Menu is set to <b>[On]</b>, printing is performed assuming letter size and A4 size to be the same size. For example, When a PDF file set to A4 size paper is printed using PDF Direct Print and letter size paper is installed in the paper tray, the file will print out. This applies similarly to the opposite case.</p>

If the problem cannot be solved, contact your sales or service representative.

# Additional Troubleshooting

Problems	Solutions
Strange noise is heard.	If a supply was recently replaced or an option attached in the area the strange noise is coming from, check the supply or option is properly attached. If the strange noise persists, contact your sales or service representative.
No e-mail is received when an Alert occurs, and after resolving an Alert.	Confirm <b>[Notify by E-mail]</b> is <b>[On]</b> using the System Menu on the Control Panel. See “System Menu”, Software Guide.
	<p>Access the printer through the Web browser, log on as an Administrator on the Web Image Monitor, and then confirm the following settings in <b>[E-mail Notification]</b> :</p> <ul style="list-style-type: none"> <li>• Device E-mail Address</li> <li>• Groups to Notify</li> <li>• Select Groups/Items to Notify</li> </ul> <p> <b>Reference</b></p> <p>For details about the settings, see Web Image Monitor Help.</p>
	<p>Access the printer through the Web browser, log on as an Administrator on the Web Image Monitor, and then confirm the settings of the SMTP server in <b>[E-mail]</b>.</p> <p> <b>Reference</b></p> <p>For details about the settings, see Web Image Monitor Help.</p>
	<p>When the power is turned off before the e-mail is transmitted, the e-mail will not be received.</p> <p>Check the e-mail address set for the destination. Confirm the printer's operation history using the Web Image Monitor's System Log menu in <b>[Network]</b>. If the e-mail was sent but not received, it is possible the destination was incorrect. Also check the information concerning error mail from the e-mail server.</p>
The setting for <b>[Notify by Email]</b> on the System Menu was changed from <b>[Off]</b> to <b>[On]</b> , but e-mail is not arriving.	After changing the setting, turn the main unit's power off and then back on again.
Error notification e-mail was received, but no error-solved e-mail is received.	<p>Check e-mail is set for sending using the Web Image Monitor's <b>[E-mail Notification]</b> at the time the error was fixed. You must click the <b>[Edit]</b> button of <b>[Detailed Settings of Each Item]</b> in <b>[E-mail Notification]</b>, and set <b>[Notify when error:]</b> to <b>[Occurs &amp; Fixed]</b> on the displayed screen.</p> <p> <b>Reference</b></p> <p>For details about the settings, see Web Image Monitor Help.</p>

Problems	Solutions
Alert Resolving is set for sending e-mail, but no Alert-resolved e-mail is sent.	If the power of the main unit is turned off after an Alert occurs, the Alert is resolved during the time the power is off: no Alert-resolved e-mail is sent.
Alert Occurrence and Alert Resolving are set for sending e-mail, but while no Alert Occurrence mail is received, Alert-resolved e-mail is received.	Alert-notification e-mail is not sent if the problem is resolved before sending. However, an Alert-resolved e-mail is sent.
Alert-notification level was changed, and e-mail stopped arriving.	If an Alert-notification e-mail, set with the earlier notification level, arrives, later e-mail will not be sent, even if the notification level is changed after.
When no date information is included in sent e-mail, the mail server has a malfunction.	Make the setting for obtaining time information from the SNTP server. Refer to the Web Image Monitor's Help to the settings.
Printing using Bluetooth is slow.	<p>When using the optional Bluetooth interface unit, do the following;</p> <ul style="list-style-type: none"> <li>• Transmit fewer print jobs.</li> <li>• Make sure no IEEE 802.11b (wireless LAN) or other Bluetooth devices are in use.</li> </ul> <p> Note</p> <ul style="list-style-type: none"> <li><input type="checkbox"/> Interference may occur with the IEEE 802.11b wireless LAN interface board. Such interference may affect the transmission speed and other functions.</li> <li>• Transmissions between the client computer and the machine can be blocked by obstructions. Move the machine or client computer if necessary.</li> </ul> <p> Note</p> <ul style="list-style-type: none"> <li><input type="checkbox"/> When you use a Bluetooth connection, print jobs are transmitted relatively slowly.</li> </ul>

If the machine is still not operating satisfactorily, contact your sales or service representative. Consult with the store where the printer was purchased for information about the location of sales or service representatives.

## Removing Misfed Paper

An error message appears if a paper misfeed occurs. The error message gives the location of the misfeed.

 **Important**

- Misfed paper may be covered in toner. Be careful not to get toner on your hands or clothes.
- Toner on prints made after removing misfed paper may be loose (inadequately fused). Make a few test prints until smudges no longer appear.
- Do not forcefully remove misfed paper, as it will tear. Torn pieces remaining inside the printer will cause further misfeeds and possibly damage the printer.

## When “Remove Misfeed Paper Tray” Appears

**★ Important**

- ❑ Forcefully removing misfed paper may cause paper to tear and leave scraps of paper in the printer. This might cause a misfeed and damage the printer.

**1** Lift the paper tray slightly. Pull it out until it stops, and then remove the misfed paper.

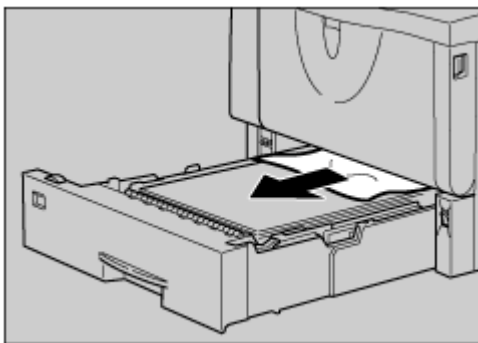

ZK01203E

**2** Carefully slide the paper tray into the printer until it stops.

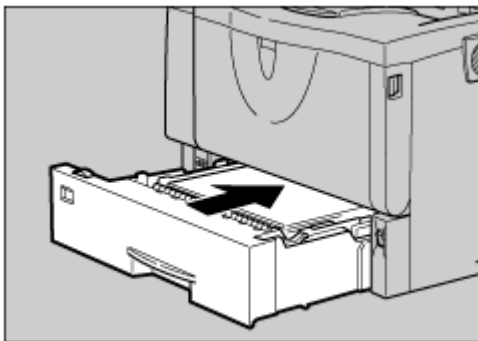

ZK01204E

**★ Important**

- ❑ Do not slide the paper tray in with force. If you do, the front and side guides might move.

- 3** Open the front cover by pushing the front cover release button, and then close it to reset the misfeed condition.

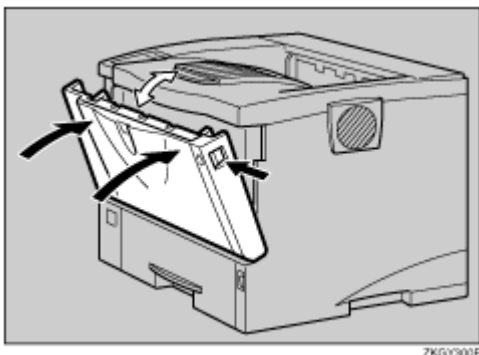

 Note

- You can apply this procedure for both the paper tray and the optional paper feed unit.
- To reset the misfeed condition, open and close the front cover, then the indicator will be off.

## When “Remove Misfeed Internal Path” Appears

**★ Important**

- ❑ Forcefully removing misfed paper may cause paper to tear and leave scraps of paper in the printer. This might cause a misfeed and damage the printer.

**1** Open the front cover by pushing the front cover release button.

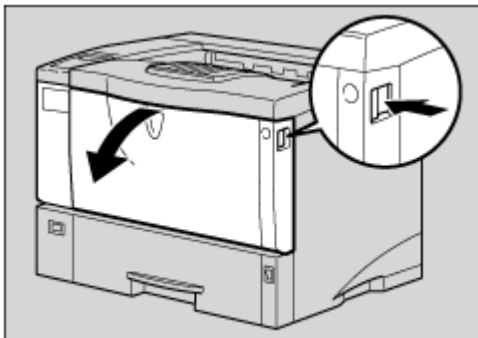

4598227

**2** Lift the front side of the toner cartridge, and then pull it out of the printer.

**★ Important**

- ❑ Be sure to put the toner cartridge on a stable, flat surface.
- ❑ Do not hold the toner cartridge upside down or stand it vertically.

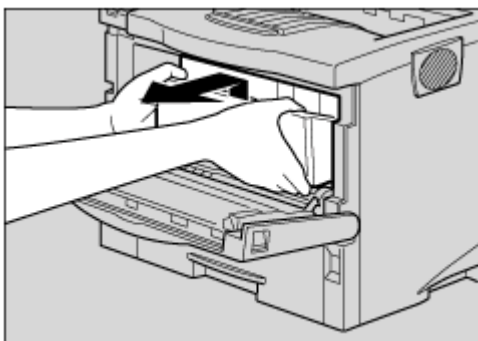

4598227



- 3** Pull out the misfed paper by holding both sides of paper. Be careful not to get toner dust on your hands or clothes.

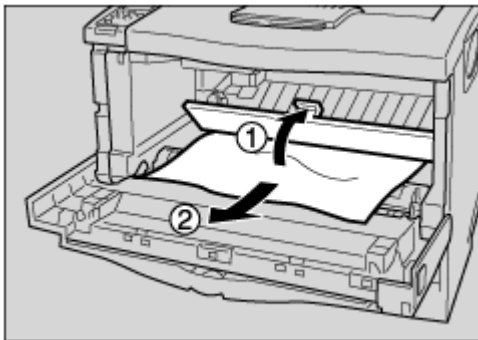

- 4** Hold the grips of the toner cartridge, and then insert it into the printer until it stops.

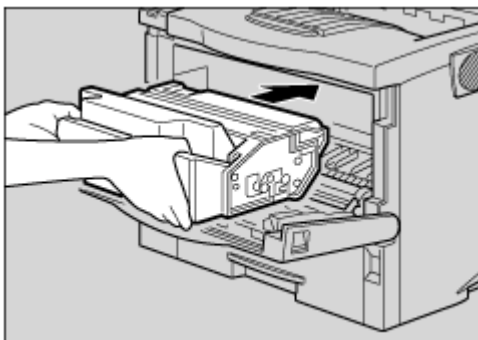

- 5** Push down the toner cartridge to settle it in appropriate position.

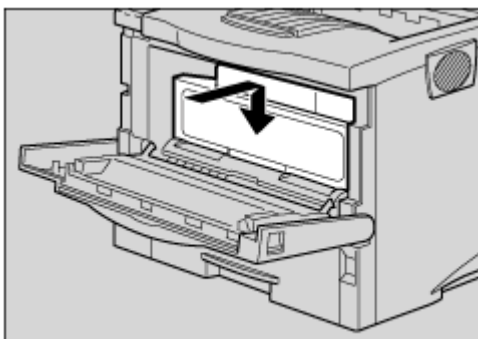

**6** Close the front cover by pressing the left and right side indentations.

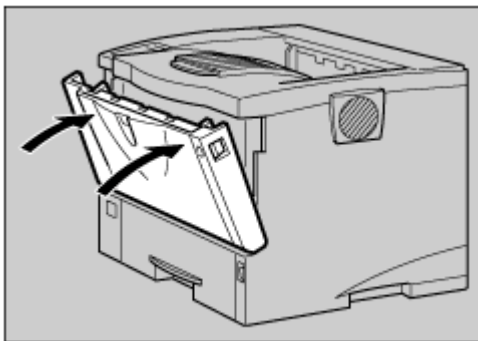

ZKGH130E

**★ Important**

- If paper is fed from the bypass tray, be sure to remove all the paper from the bypass tray and close it before opening the front cover.

# When “Remove Misfeed Paper Exit Cover” Appears

## **⚠ CAUTION**

- *When removing misfed paper, do not touch the fusing section because it becomes very hot.*
- *The fusing unit becomes very hot. When installing the new fusing unit, turn off the printer and wait about an hour. After that, install the new fusing unit. Not waiting for the unit to cool down can result in a burn.*

## **★ Important**

- Forcefully removing misfed paper may cause paper to tear and leave scraps of paper in the printer. This might cause a misfeed and damage the printer.**

---

## Removing misfed paper from the exit cover

---

### **1** Open the paper exit cover.

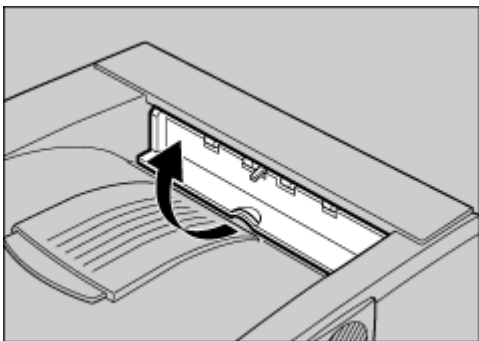

ZKGY301E

### **2** Remove the misfed paper.

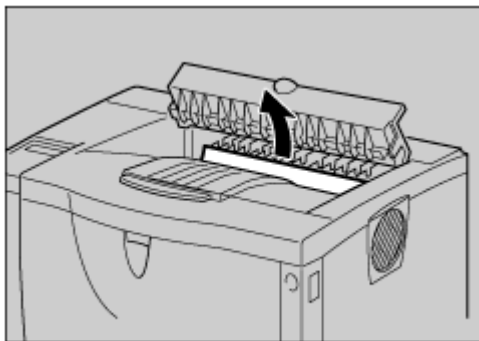

ZKGY380E

**3** Close the paper exit cover until it clicks.

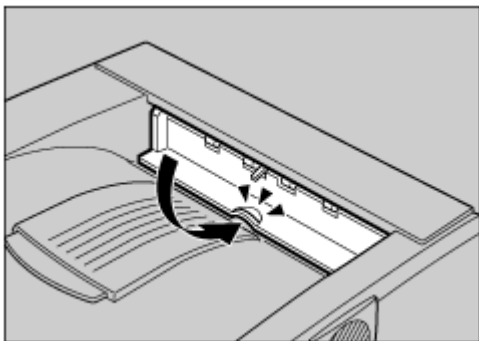

---

### Removing misfed paper from the fusing unit

---

**1** Open the rear cover by pushing the two knobs.

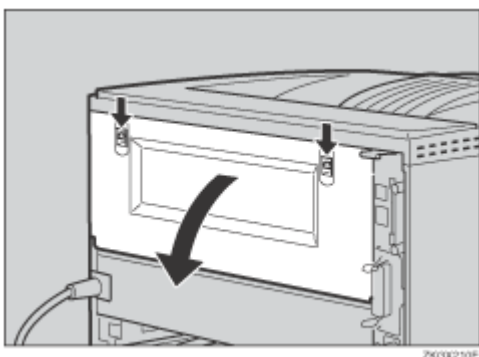

**2** Remove the rear cover in a horizontal direction.

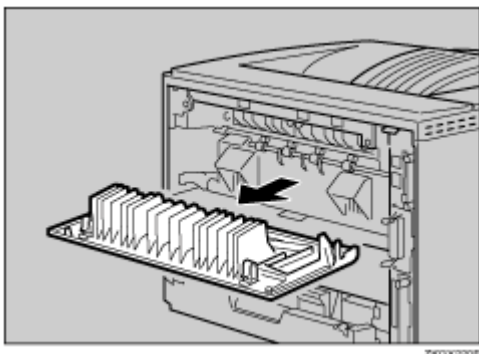

**3** Lift the lock levers of the fusing unit as shown in the illustration.

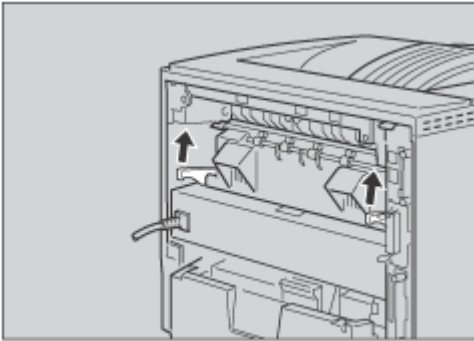

ZK0X222E

**4** Pull the fusing unit out.

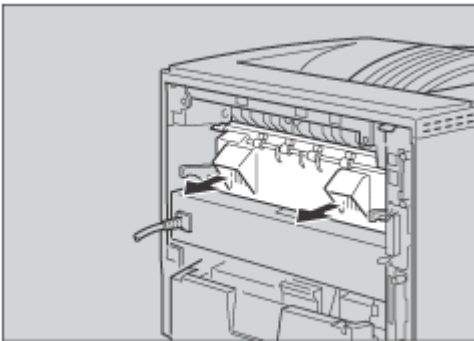

ZK0X223E

**5** Hold the tab, and then remove the misfed paper.

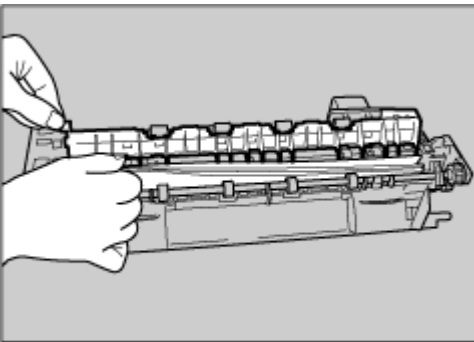

ZK0Y410E

**★ Important**

- Do not touch the metal part of the fusing unit. It becomes very hot. Touching it could result in a burn.

**6** Insert the fusing unit until it stops.

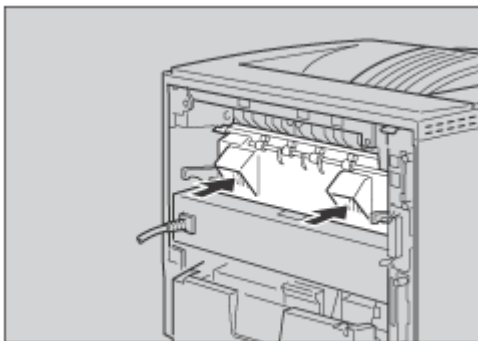

ZK3X224E

**7** Push the lock levers of the fusing unit down until it clicks.

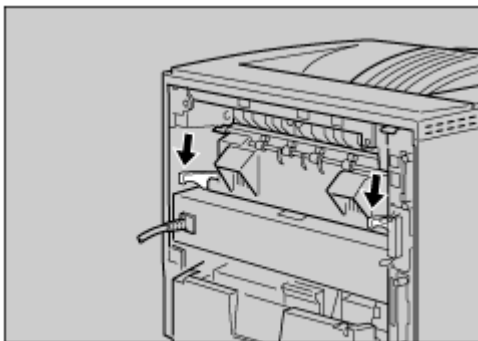

ZK3X225E

**8** Insert the rear cover to the inside grooves on both sides of the printer in a horizontal direction.

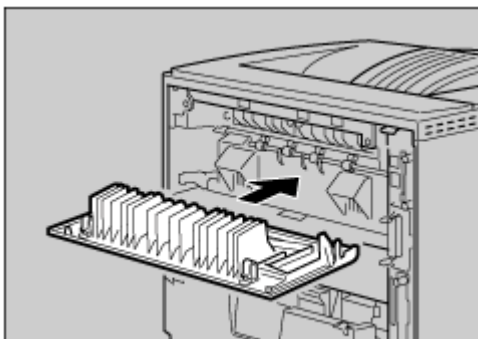

ZK3X221E

**9** Close the rear cover.

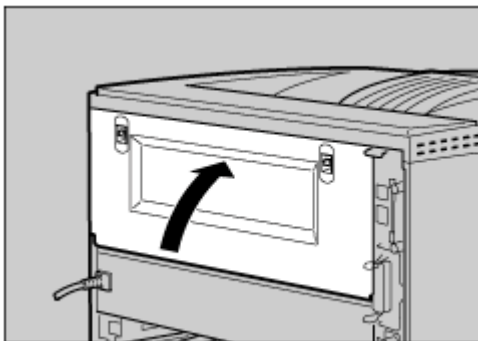

ZK9X211E

# When “Remove Misfeed Duplex Unit” Appears

## **⚠ CAUTION**

- *When removing misfed paper, do not touch the fusing section because it becomes very hot.*

## **★ Important**

- ❑ **Forcefully removing misfed paper may cause paper to tear and leave scraps of paper in the duplex unit. This might cause a misfeed and damage the printer.**

---

## Removing the misfed paper inside the cover

---

- 1** Open the rear cover of the duplex unit.

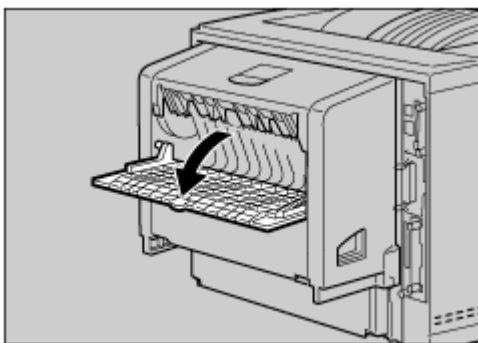

ZKGY310E

- 2** Remove the misfed paper.

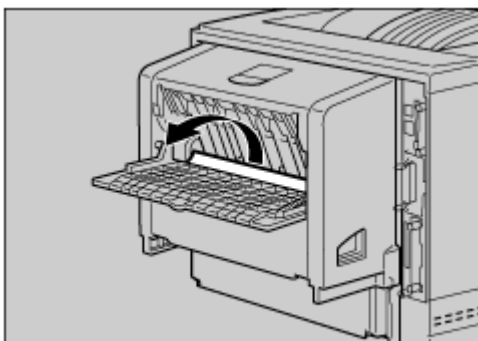

ZKGY320E



**3** Close the rear cover of the duplex unit.

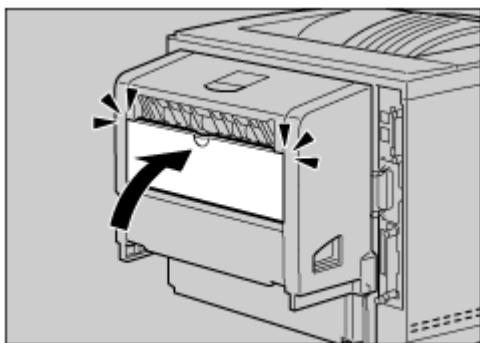

ZKGY330E

**4** Lift the lever (①), and then open the cover of the duplex unit (②).

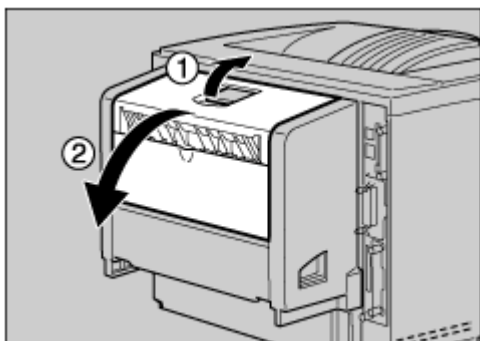

ZKGY341E

**5** Remove the misfed paper.

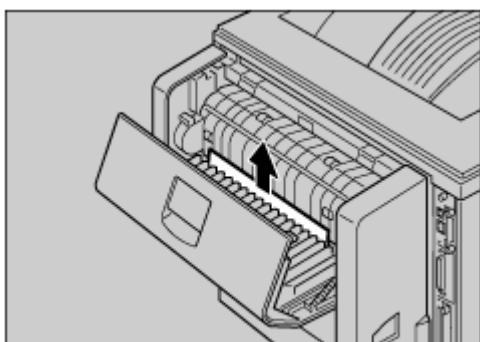

ZKGY350E

**6** Close the cover of the duplex unit.

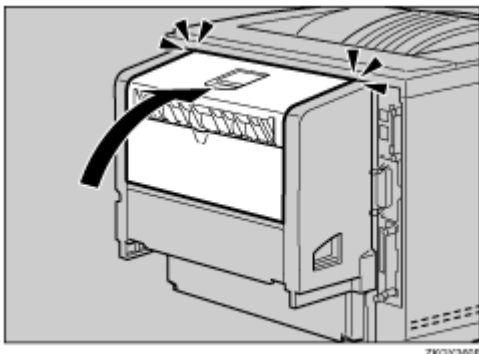

---

Removing misfed paper inside the duplex unit

---

**1** Push down the lever on the right side of the duplex unit (①), and then pull it out until it stops (②).

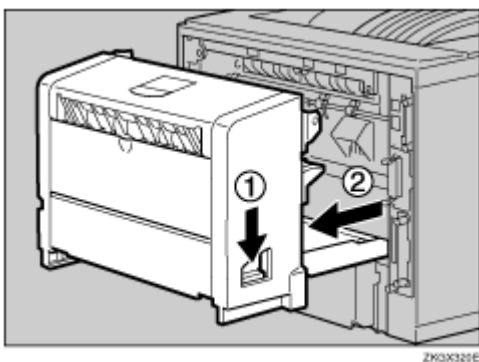

**2** Lift the guide board inside the duplex unit, and then remove the misfed paper.



**★ Important**

- ❑ When A5 paper misfeeds, you might not be able to remove it by pulling the duplex unit out. In this case, pull the paper tray out, and then remove the paper.

- 3** Align the power cable with the groove of the left side of the duplex unit, and then insert the duplex unit into back of the printer aligning the rails inside of the printer until it is connected.

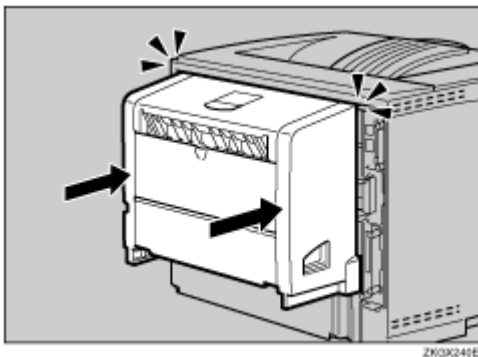

**☰ Reference**

If the error message appears again, the misfed paper might be left in the printer. Confirm that any torn paper scraps are not in the inside of the printer. For more information, see [p.96 “When “Remove Misfeed Internal Path” Appears”](#).

# Moving and Transporting the Printer

## CAUTION

- *When lifting the machine, use the inset grips on both sides. Otherwise the printer could break or cause injury if dropped.*
- *When you move the printer, remember to unplug the power cord from the wall outlet to avoid a fire or an electric shock.*
- *When you pull out the plug from the socket, grip the plug to avoid damaging the cord and causing a fire or an electric shock.*

Repack the printer in its original packing materials for transporting.

## Important

- Be sure to disconnect all cables from the printer before transporting it.
- The printer is a precision piece of machinery. Take care to avoid damage during shipment.
- If the optional paper feed unit is installed, remove it from the printer, and then move them separately.

---

## Moving the Printer

---

## CAUTION

- *The machine weight is approximately 20 kg (44.1 lb.).*
- *When lifting the machine, use the inset grips on both sides. Otherwise the printer could break or cause injury if dropped.*
- *Before moving the machine, unplug the power cord from the outlet. If the cord is unplugged abruptly, it could become damaged. Damaged plugs or cords can cause an electrical or fire hazard.*

---

### Moving the printer in the short distance

---

#### **1** Be sure to check the following points:

- The power of the printer is turned off.
- The power cable is unplugged from the wall outlet.
- The interface cable is unplugged from the printer.

#### **2** If the external options are installed, remove them.

See Setup Guide and follow the steps backwards for removing options.

#### **3** Be sure to close the Bypass Tray and the front cover.

**4** Lift the printer and move it to the place where you want to install it.

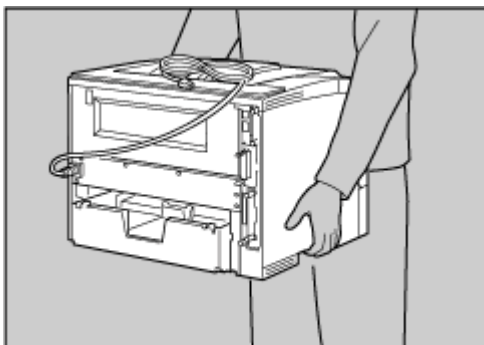

Z6C422 1E

**★ Important**

- When lifting the machine, use the inset grips on both sides. Otherwise the printer could break or cause injury if dropped.
- Be sure to move the printer horizontally. Moving the printer facing up on down may cause the toner to scatter.
- If the optional paper feed unit(s) is installed, detach and move the printer separately. Never move the printer with the paper feed unit(s) attached.

**5** If you removed options, reinstall them.

See Setup Guide for installing options.

# Consumables

## ⚠ CAUTION

- *Our products are engineered to meet the highest standards of quality and functionality. When purchasing expendable supplies, we recommend using only those specified by an authorized dealer.*

## Toner Cartridge

Name	Average printable number of pages <sup>*1</sup>
Toner Cartridge	20,000 pages

\*1 A4, 3% test chart

### ↓ Note

- The actual number of printed pages you get from a particular toner cartridge depends on the type and size of paper you are using, the contents of your print images, and printing environment conditions. All this means that a toner cartridge might require replacement sooner than the normal life described above.
- The number of printable pages that can be expected from the starter toner cartridge included in the printer is about 10,000 pages (A4, 3% chart).
- Toner cartridge may need to be changed sooner than indicated above due to deterioration over the period of use.
- Toner cartridge (consumable) is not covered by warranty. However, if there is problem, contact the store where they were purchased.
- When you first use this printer, use the toner cartridge packaged with the printer.
- Numbers of pages that can be printed using the toner cartridge supplied with this printer are as follows:

Name	Average printable number of pages
Toner Cartridge	3,000 pages

## Maintenance Kit

### ❖ Maintenance Kit Type 610

Name	Average printable number of pages <sup>*1</sup>
Fusing Unit	90,000 pages
Transfer Roller	90,000 pages
Paper Feed Roller × 3	90,000 pages

Name	Average printable number of pages <sup>1</sup>
Friction Pad × 3	90,000 pages

<sup>\*1</sup> A4, 3% test chart

↓ Note

- The actual number of printable pages varies depending on the image volume and density, number of pages to be printed at a time, paper type and paper size used, and environmental conditions such as temperature and humidity.
- Maintenance kit (consumables) are not covered by warranty. However, if there is problem, contact the store where they were purchased.
- It is required to change the maintenance kit after every 90,000 pages have been printed. However, it may be necessary to change the parts earlier depending on their operating period.

# Specifications

## Mainframe



### ❖ Configuration:

Desktop

### ❖ Print Process:

Laser beam scanning & Electrophotographic printing  
Dual component toner development

### ❖ First Print Speed:

7.5 sec or less (A4 , 8 1/2 x 11 )

 Note

- If the printer has not been used for a while, there may be a short delay before the first page starts printing.

### ❖ Printing Speed:

Maximum 35 pages per minute (A4 , 8 1/2 x 11 )

 Note

- Continuous printing on sheets with a width of 230 mm or smaller may decrease the printing speed depending on the temperature control of the fusing unit.

### ❖ Interface:

Standard 36-pin printer cable and a parallel port on the host computer  
IEEE 1284 I/F (Compatible, ECP, Nibble)

- Do not use a cable more than 2.5 meters (8.2 feet) long.
- USB 2.0
- Bidirectional IEEE1284
- 10/100Base-TX

### ❖ Resolution:

1,200 × 1,200 dpi (PCL 6, RPCS, PS, PDF)  
600 × 600 dpi (PCL 6, PCL 5e, RPCS, PS, PDF)  
300 × 300 dpi (PCL 5e, PDF)

### ❖ Printer Language:

PCL 6 (XL) , PCL 5e, RPCS, Adobe PostScript 3

### ❖ Fonts:

**PCL 6, PCL 5e**

Agfa Monotype 35 Intellifonts, 10 TrueType fonts, 13 International fonts, and 1 Bitmap font.



**PostScript, PDF**

136 fonts (Type 2:24, Type 14:112)

❖ **Paper size:**See [p.5 “Paper and Other Media Supported by This Printer”](#).❖ **Paper Weight:**See [p.5 “Paper and Other Media Supported by This Printer”](#).❖ **Media Type:**See [p.10 “Types of Paper and Other Media”](#).❖ **Power Source:**

120 V, 60 Hz, 8.4 A or more

❖ **Power Consumption:**• **With Options**

Maximum	920 W or less
Energy Saver	9 W

• **Printer Only**

Maximum	850 W or less
Energy Saver	5.5 W

❖ **Noise Emission: <sup>\*1</sup>****Sound Power Level**

	Mainframe only
During Printing	67 dB (A)
Stand-by	40 dB (A)

**Sound Pressure level <sup>\*2</sup>**

	Mainframe only
During Printing	56 dB (A)

<sup>\*1</sup> The following measurements are actual values made in accordance with ISO7779.

<sup>\*2</sup> Measured at the position of a bystander.

❖ **Dimensions: <sup>\*1</sup>**

	Width	Depth	Height
Printer only (tray not extended)	478 mm (18.4 inches)	437 mm (17.2 inches)	343 mm (13.5 inches)
Printer only (tray extended)	478 mm (18.4 inches)	572 mm (22.6 inches)	343 mm (13.5 inches)

	Width	Depth	Height
With one optional feed unit	478 mm (18.4 inches)	437 mm (17.2 inches)	473 mm (18.6 inches)
With two optional feed units	478 mm (18.4 inches)	437 mm (17.2 inches)	603 mm (23.7 inches)

\*1 Measurement conditions: With paper tray, Bypass Tray and output tray extension closed.

❖ **Weight:**

Approximately 20 kg (44.1 lb.) (toner cartridge and power cable included)

❖ **Warm-up Time:**

Less than 19 seconds (23°C, 73F)

❖ **Paper Capacity:**

Standard paper tray	500 sheets <sup>*1</sup> (80 g/m <sup>2</sup> , 20 lb.)
Bypass Tray <sup>*2</sup>	100 sheets <sup>*1</sup> (80 g/m <sup>2</sup> , 20 lb.)
Optional Paper Feed Unit × 2	500 sheets × 2 <sup>*1</sup> (80 g/m <sup>2</sup> , 20 lb.)
Optional Envelope Feeder <sup>*3</sup>	60 envelopes <sup>*4</sup>

\*1 Paper weight: 60 - 105 g/m<sup>2</sup> (16 - 28 lb.)

\*2 You can load up to 10 envelopes (55 - 157 g/m<sup>2</sup>, 14 - 42 lb.) at the same time.

\*3 To use the envelope feeder unit, the optional paper feed unit is required. The paper tray of the feed unit can be replaced with the envelope feeder unit.

\*4 For more information about envelopes, see [p.12 "Envelopes"](#).

❖ **Paper Output Capacity:**

250 sheets (80 g/m<sup>2</sup>, 20 lb.)

❖ **Memory:**

Standard 128 MB, up to 256 MB (with the optional memory unit)

❖ **Network:**

**Topology:** Ethernet (10BaseT/100BaseTX)

**Protocol:** TCP/IP, NetBEUI, IPX/SPX, AppleTalk

❖ **Optional Equipment:**

- Paper Feed Unit Type 610
- Envelope Feeder Type 610
- Duplex Unit AD610
- Memory Unit Type C 256MB
- Hard Disk Drive Type 2600
- 1394 Interface Unit Type 4510
- 802.11b Interface Unit Type F

- Bluetooth Interface Unit Type C

---

## Options

---

### Paper Feed Unit Type 610

---

- ❖ **Dimensions (W×D×H):**  
468 × 410 × 130 mm (18.4 × 14.8 × 5.1 inches)  
(without pins on the unit)
- ❖ **Paper Weight:**  
60 - 105 g/m<sup>2</sup> (16 - 28 lb.)
- ❖ **Paper Size:**  
See [p.5 "Paper and Other Media Supported by This Printer"](#).

### Envelope Feeder Type 610

---

- ❖ **Dimensions (W×D×H):**  
468 × 410 × 130 mm (18.4 × 16.1 × 5.1 inches)
- ❖ **Paper Weight:**  
72 - 90 g/m<sup>2</sup> (19 - 24 lb.)
- ❖ **Paper Size:**  
See [p.5 "Paper and Other Media Supported by This Printer"](#).

### Duplex Unit AD610

---

- ❖ **Dimensions (W×D×H):**  
419 × 378 × 257 mm (16.5 × 14.9 × 10.2 inches)
- ❖ **Paper Size:**  
See [p.5 "Paper and Other Media Supported by This Printer"](#).
- ❖ **Paper Weight:**  
60 - 105 g/m<sup>2</sup> (17 - 28 lb.)
- ❖ **Weight:**  
6 kg (13.2 lb.)

### Hard Disk Drive Type 2600

---

- ❖ **Storage Capacity (Formatted):**  
6 GB

You can install PostScript fonts with this optional Hard Disk Drive. With a Macintosh, types of fonts supported are PostScript Type 1 and PostScript Type 2. To download them, use PS Utility for Mac.

### Memory Unit Type C 256MB

---

- ❖ **Module Type:**  
SO-DIMM (Small Outline Dual-in-line Memory Module)
- ❖ **Memory Type:**  
SDRAM (Synchronous Dynamic RAM)
- ❖ **Number of Pins:**  
144 pins

### 1394 Interface Unit Type 4510

---

- ❖ **Transmission Spec.:**  
IEEE 1394
- ❖ **Device Class:**  
SCSI print, IP over 1394
- ❖ **Interface Connector:**  
IEEE 1394 (6 pins × 2)
- ❖ **Required cable:**  
1394 interface cable (6 pins x 4 pins, 6 pins x 6 pins)

 **Important**

- You cannot plug devices together to create loops.
- Do not use a cable more than 4.5 meters (14.8 feet) long.

- ❖ **Connectable number of device in a bus:**  
Maximum 63
- ❖ **Allowed cable hops in a bus:**  
Maximum 16
- ❖ **Power supply:**  
Nonpower supply  
Cable Power repeated (IEEE 1394a-2000 compliant)

### 802.11b Interface Unit Type F

---

- ❖ **Transmission Spec.:**  
Based on IEEE 802.11b (Wireless LAN)

❖ **Protocol:**

TCP/IP, NetBEUI, IPX/SPX, AppleTalk



SmartDeviceMonitor and Web Image Monitor are supported.

❖ **Data Transfer Speed:**

Auto select from below speed

1 Mbps, 2 Mbps, 5.5 Mbps, 11 Mbps

❖ **Frequency Range:**

- Inch version:  
2412-2464 MHz (1-11 channels)
- Metric version:  
2412-2472 MHz (1-13 channels)

❖ **Transmittable Distance:**

1 Mbps 400 m <sup>\*1</sup>

2 Mbps 270 m <sup>\*1</sup>

5.5 Mbps 200 m <sup>\*1</sup>

11 Mbps 140 m <sup>\*1</sup>

\*1 These figures are a guideline for outdoor use. In general, the transmittable distance indoors is 10-100 m, depending on the environment.

❖ **Transmission Mode:**

ad hoc mode and infrastructure mode

## Bluetooth Interface Unit Type C

---

❖ **Supported Profiles:**

SPP (Serial Port Profile)

HCRP (Hardcopy Cable Replacement Profile)

BIP (Basic Imaging Profile)

❖ **Frequency Range:**

2 GHz ISM band

❖ **Data Transmission Speed:**

732 kbps



The transmission speed is adjusted according to factors such as the distance and obstacles between the devices, radio signal condition and Bluetooth adaptor.

❖ **Maximum Range:**

10 m

## Free Manuals Download Website

<http://myh66.com>

<http://usermanuals.us>

<http://www.somanuals.com>

<http://www.4manuals.cc>

<http://www.manual-lib.com>

<http://www.404manual.com>

<http://www.luxmanual.com>

<http://aubethermostatmanual.com>

Golf course search by state

<http://golfingnear.com>

Email search by domain

<http://emailbydomain.com>

Auto manuals search

<http://auto.somanuals.com>

TV manuals search

<http://tv.somanuals.com>