

**Model RN-MF1
Machine Codes: M016/M017
Field Service Manual**

30 November, 2009

Safety Notices

Important Safety Notices

Prevention of Physical Injury

1. Before disassembling or assembling parts of the machine and peripherals, make sure that the machine power cord is unplugged.
2. The wall outlet should be near the machine and easily accessible.
3. If any adjustment or operation check has to be made with exterior covers off or open while the main switch is turned on, keep hands away from electrified or mechanically driven components.
4. The machine drives some of its components when it completes the warm-up period. Be careful to keep hands away from the mechanical and electrical components as the machine starts operation.
5. The inside and the metal parts of the fusing unit become extremely hot while the machine is operating. Be careful to avoid touching those components with your bare hands.

Health Safety Conditions

Toner is non-toxic, but if you get either of them in your eyes by accident, it may cause temporary eye discomfort. Try to remove with eye drops or flush with water as first aid. If unsuccessful, get medical attention.

Observance of Electrical Safety Standards

The machine and its peripherals must be serviced by a customer service representative who has completed the training course on those models.

Safety and Ecological Notes for Disposal

1. Do not incinerate toner bottles or used toner. Toner dust may ignite suddenly when exposed to an open flame.
2. Dispose of used toner, the maintenance unit which includes developer or the organic photoconductor in accordance with local regulations. (These are non-toxic supplies.)
3. Dispose of replaced parts in accordance with local regulations.

WARNING

- To prevent a fire or explosion, keep the machine away from flammable liquids, gases, and aerosols. A fire or an explosion might occur.

⚠ CAUTION

- The Controller board on the MF model contains a lithium battery. The danger of explosion exists if a battery of this type is incorrectly replaced. Replace only with the same or an equivalent type recommended by the manufacturer. Discard batteries in accordance with the manufacturer's instructions and local regulations

Laser Safety

The Center for Devices and Radiological Health (CDRH) prohibits the repair of laser-based optical units in the field. The optical housing unit can only be repaired in a factory or at a location with the requisite equipment. The laser subsystem is replaceable in the field by a qualified Customer Engineer. The laser chassis is not repairable in the field. Customer engineers are therefore directed to return all chassis and laser subsystems to the factory or service depot when replacement of the optical subsystem is required.

⚠ WARNING

- Use of controls, or adjustment, or performance of procedures other than those specified in this manual may result in hazardous radiation exposure.

⚠ WARNING

WARNING:

Turn off the main switch before attempting any of the procedures in the Laser Optics Housing Unit section. Laser beams can seriously damage your eyes.







CAUTION MARKING:



m016i500

Symbols, Abbreviations and Trademarks

This manual uses several symbols and abbreviations. The meaning of those symbols and abbreviations are as follows:

	See or Refer to
	Clip ring
	Screw
	Connector
	Clamp
	E-ring
SEF	Short Edge Feed
LEF	Long Edge Feed

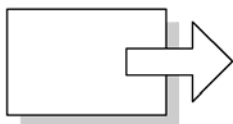

Short Edge Feed (SEF)

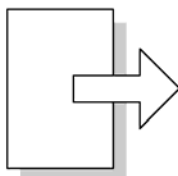

Long Edge Feed (LEF)

Trademarks

Microsoft[®], Windows[®], and MS-DOS[®] are registered trademarks of Microsoft Corporation in the United States and /or other countries.

PostScript[®] is a registered trademark of Adobe Systems, Incorporated.

PCL[®] is a registered trademark of Hewlett-Packard Company.

Ethernet[®] is a registered trademark of Xerox Corporation.

PowerPC[®] is a registered trademark of International Business Machines Corporation.

Other product names used herein are for identification purposes only and may be trademarks of their respective companies. We disclaim any and all rights involved with those marks.

TABLE OF CONTENTS

Safety Notices.....	1
Important Safety Notices.....	1
Laser Safety.....	2
Symbols, Abbreviations and Trademarks.....	3
Trademarks.....	3

1. Product Information

Specifications.....	9
Machine Overview.....	10
Component Layout.....	10
Paper Path.....	11
Drive Layout.....	12
Machine Configuration.....	13

2. Installation

Installation Requirements.....	15
Environment.....	15
Machine Level.....	16
Machine Space Requirement.....	16
Power Requirements.....	16
Installation Procedure.....	17

3. Preventive Maintenance

PM Intervals.....	19
PM Parts.....	19
Yield Counter.....	19

4. Replacement and Adjustment

Before You Start.....	21
Special Tools.....	22
Exterior Covers.....	23
Front Cover.....	23
Left Cover.....	24
Rear Cover.....	27
Right Cover.....	28
Top Cover.....	29
ADF.....	31

ADF Unit.....	31
Original Tray.....	32
ADF Feed Unit.....	32
ADF Separation Pad.....	33
ADF Front Cover	33
ADF Rear Cover.....	34
ADF Cover.....	34
ADF Motor.....	35
Original Set Sensor.....	36
ADF Cover Open Sensor.....	37
ADF Feed Sensor.....	38
ADF Drive Board.....	39
Scanner Unit.....	40
Operation Panel.....	40
Scanner Top Cover.....	41
Scanner Carriage Unit.....	42
Exposure Lamp.....	44
Lamp Stabilizer Board.....	45
Scanner Motor.....	46
Laser Unit.....	48
Caution Decal Locations.....	48
Laser Unit.....	48
Polygon Mirror Motor.....	49
Paper Feed and Exit.....	51
Paper Feed Roller.....	51
Friction Pad.....	52
Paper End Sensor.....	52
By-pass Feed Roller.....	52
By-Pass Feed Roller Friction Pad.....	54
By-pass Feed Sensor.....	55
Paper Feed Clutch.....	55
Relay Clutch.....	57
Registration Clutch.....	57

Toner End Sensor.....	57
Paper Exit Sensor.....	58
Relay Sensor.....	58
Inverter Sensor.....	59
Registration Roller and Sensor.....	59
Paper Transfer.....	63
Transfer Roller.....	63
Fusing.....	64
Fusing Unit.....	64
Thermostat.....	66
Thermistor.....	67
Fusing Lamp.....	68
Hot Roller.....	69
Pressure Roller.....	70
Hot Roller Stripper Pawls.....	70
Motors.....	72
Main Motor.....	72
Duplex Motor (For M017).....	72
Electrical Components.....	74
Layout of PC Boards.....	74
PSU.....	78
Charge Terminal Case.....	82
Others.....	83
Cooling Fan.....	83
Speaker.....	83
Quenching Lamp.....	84
Image Adjustment.....	85
Registration Adjustment.....	85

5. System Maintenance Reference

Service Program Mode.....	87
Overview.....	87
Maintenance Mode Menu.....	87
Fax Service Test Menu.....	104

Configuration and Maintenance Page	106
Overview.....	106
Firmware Updating.....	108
Checking the Machine Firmware Version.....	108
Updating the Controller Firmware.....	108
Updating the Engine Firmware.....	110
Updating the Boot Loader Firmware.....	112
Updating Failure.....	112
FW Update Tool Messages.....	112

6. Troubleshooting

Service Call Conditions.....	117
Summary.....	117
Engine SC.....	117
Image Problems.....	124
Overview.....	124
Test Page Printing.....	124
Test Pattern Printing.....	125
Dark lines in halftone areas at 75mm Intervals.....	126
Jam.....	127
Jam Sensor Layout.....	127
Jam Message List.....	128

7. Energy Saving

Energy Save.....	131
Energy Saver Modes.....	131
Paper Save.....	133
Effectiveness of Duplex/Combine Function.....	133



1. Product Information

Specifications

1

See "Appendices" for the following information:

- "General Specifications"
- "Printer"
- "Copier"
- "Scanner"
- "Fax"
- "Supported Paper Sizes"

Machine Overview

1

Component Layout

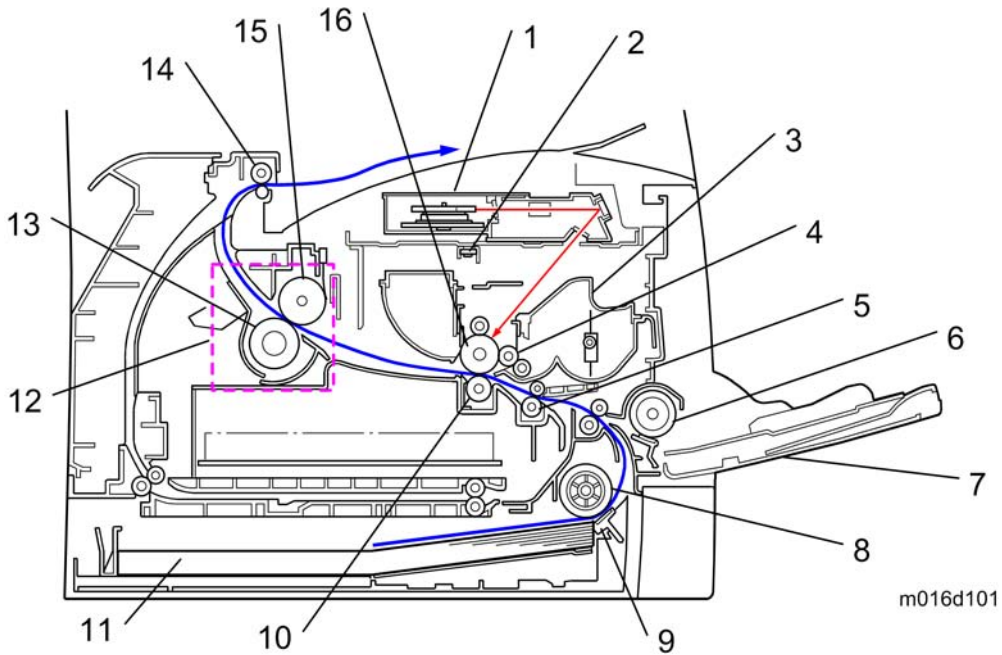

1.	Laser unit	9.	Friction pad
2.	Quenching lamp	10.	Transfer roller
3.	Cartridge (AIO-type)	11.	Paper Tray
4.	Development roller	12.	Fusing Unit
5.	Registration roller	13.	Pressure Roller
6.	By-pass feed roller	14.	Paper exit roller
7.	By-pass feed tray	15.	Hot Roller
8.	Paper feed roller	16.	Drum

Paper Path

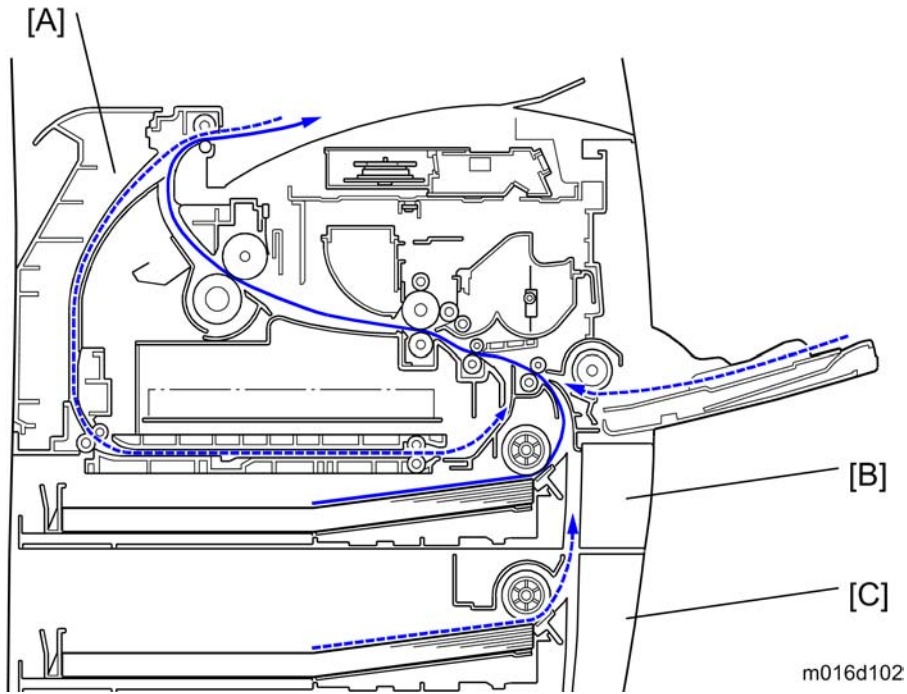

[A] Duplex section (For M017)

[B] Standard paper tray unit

[C] Optional paper tray unit

Drive Layout

1

- M016 -

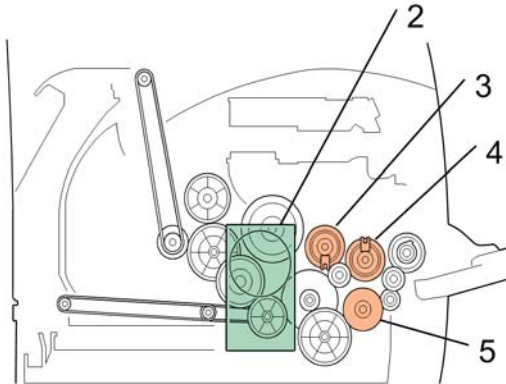

- M017 -

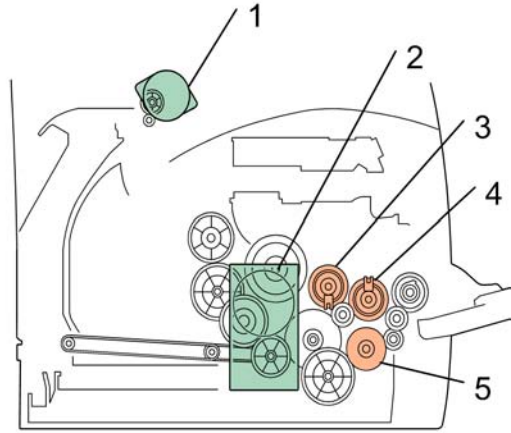

m016d103

- | | |
|------------------------|----------------------|
| 1. Duplex Motor | 4. Replay Clutch |
| 2. Main Motor | 5. Paper Feed Clutch |
| 3. Registration Clutch | |

Machine Configuration

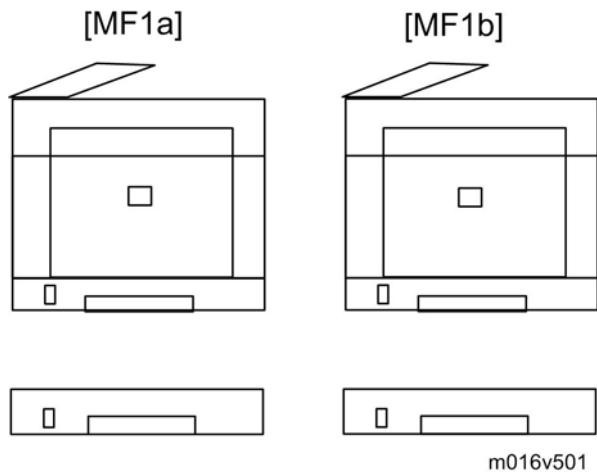

Models	Duplex Unit	Optional Memory	Optional Tray (M355)	PCL PS	Fax	USB Host
RN-MF1a (M016)	NA	NA	250x1	Yes	Yes	Yes
RN-MF1b (M017)	Auto	NA	250x1	Yes	Yes	Yes

NA: Not Available

2. Installation

Installation Requirements

Environment

2

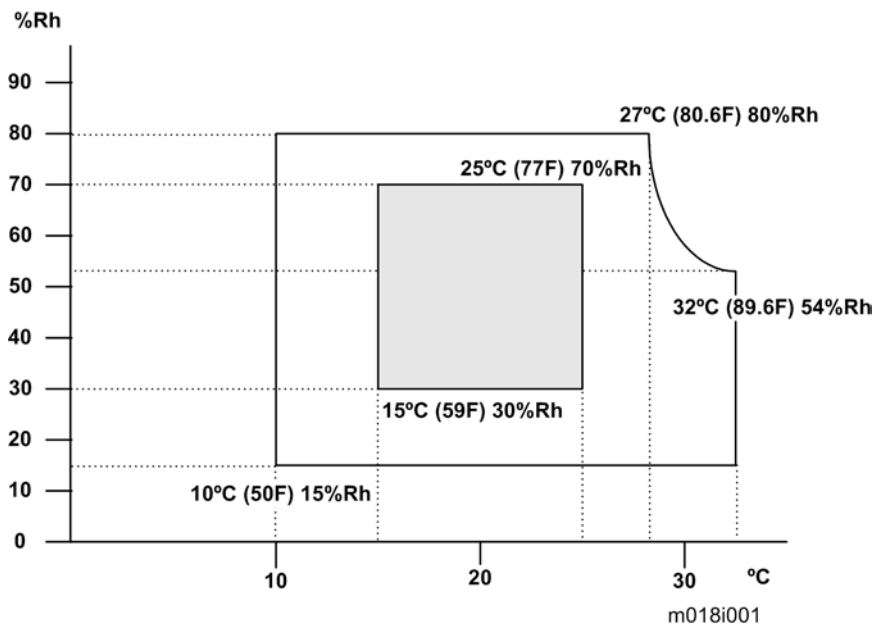

1. Temperature Range: 10°C to 32°C (50°F to 89.6°F)
2. Humidity Range: 15% to 80% RH
3. Ambient Illumination: Less than 2,000 lux (do not expose to direct sunlight)
4. Ventilation: 3 times/hr/person
5. Do not put the machine in areas with sudden temperature changes. This includes:
 - Areas directly exposed to cool air from air conditioning
 - Areas directly exposed to heat from a heating system.
6. Do not put the machine in areas exposed to corrosive gas.
7. Do not install the machine at locations over 2,000 m (6,562 ft.) above sea level.
8. Put the machine on a strong, level base. (Tilting towards any side must be no more than 3 mm.)
9. Do not put the machine in areas with strong vibrations.

Machine Level

Front to back: Within 5 mm (0.2") of level

Right to left: Within 5 mm (0.2") of level

2

Machine Space Requirement

Put the machine near a power source with these clearances:

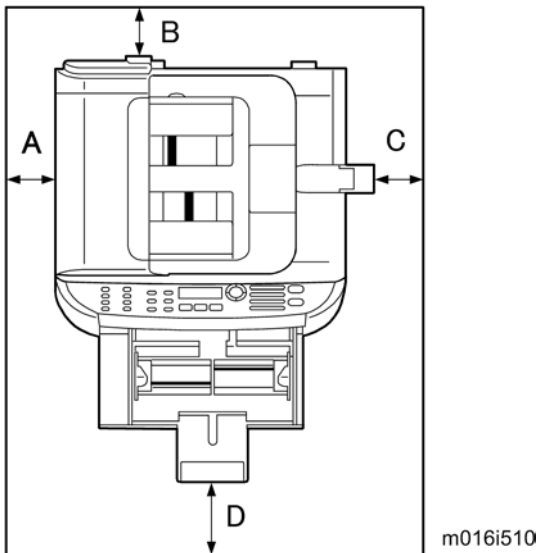

A: Over 10 cm (4")

B: Over 20 cm (7.9")

C: Over 20 cm (7.9")

D: Over 70 cm (27.6")

Power Requirements

⚠ CAUTION

- Make sure that the plug is tightly in the outlet.
- Avoid multi-wiring.
- Make sure that you ground the machine.

Input voltage level	NA: 120 V, TW: 110 V, 60 Hz: Less than 10 A EU/ Asia/ CHN: 220 V to 240 V, 50 Hz/60 Hz: Less than 5 A
---------------------	--

Permitted voltage fluctuation: 10%

Do not set anything on the power cord.
--

Installation Procedure

Refer to the "User Guide".

3. Preventive Maintenance

PM Intervals

PM Parts

There are no PM parts in this machine.

Note

- Other than the three Yield Parts listed below, there are essentially no PM parts required for this product.
- These three items will need to be replaced in cases where their yield is near, however, given the ACV (Average Copy Volume) for this product, these "yield parts *1 " are expected to outlast the working life of the machine.

*1 **"Yield Parts"**: Parts whose expected yield is longer than the machine lifetime when taking into consideration the machine's ACV.

Description	Expected Yield	Q'ty/unit
Paper Feed Roller	120 K prints	1
Transfer Roller	120 K prints	1
Fusing Unit	120 K prints	1

Yield Counter

Yield counters for each yield part can be checked by the following methods.

Configuration Page

Cartridge & Parts Information

Print Cartridge : ■■■■■■
Fuser Unit : ■■■■■■
Transfer Roller : ■■■■■■
Paper Feed Roller : ■■■■■■

m016s115

These yield counters are printed under the supplies Info on the "Configuration Page" as shown above.

Web Image Monitor

Print Cartridge & Replaceable Parts Information

	0	50	100	
Black Toner				Remaining Level 5
Fuser Unit				Status OK
Transfer Roller Unit				Status OK
Paper Feed Roller Unit				Status OK

Paper Tray

Tray 1		Status OK	Letter <input type="checkbox"/>	Plain Paper
Bypass Tray		Out of Paper	Letter <input type="checkbox"/>	Plain Paper

m016s116

These yield counters are displayed under the "Toner" on the "Status" page as shown above.

Note

- The machine displays "Life End Feed Roller", "Life End Transfer Roller" or "Life End Fuser Unit" when one of these counters reaches each yield.

Counter Reset

The process below shows how to reset the yield counters.

1. Enter the "Maintenance Mode".
2. Select "Engine Maintenance", and then press "OK" key.
3. Select "Reset Fusing Unit Life", "Reset Transfer Roller Life" or "Reset Paper Feed Life" and then press "OK" key.
4. Select "Execute" and then press "OK" key.
5. Exit the "Maintenance Mode".

4. Replacement and Adjustment

Before You Start

CAUTION

- If there are printer jobs in the machine, print out all jobs in the printer buffer.
- Turn off the main power switch and unplug the machine before you do the procedures in this section.

Special Tools

- PC: Windows 2000/XP/Vista, Windows Server 2003/2003 R2, 2008.
- USB or network cable

↓ Note

- A computer is necessary to update the firmware.

Exterior Covers

Front Cover



m016i501

1. Pull out the standard paper tray [A].

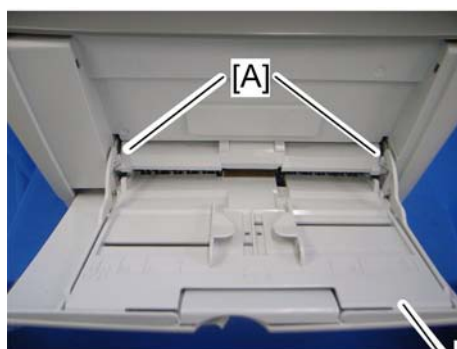

m016i511

2. Remove two tabs [A].
3. Pull out the bypass tray [B].

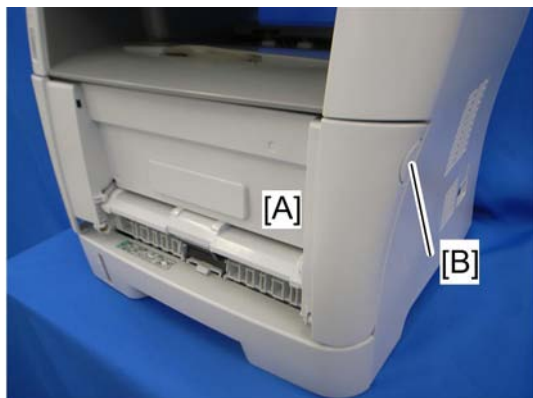

m016r693

4

4. Open the front cover [A].

Note

- To open the front cover, push the cover release button [B] and (carefully) pull the cover forward and open (it hinges downward).

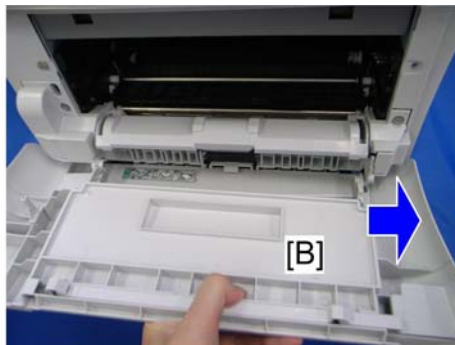
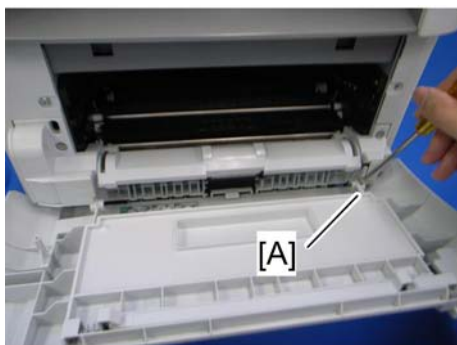

m016r692

5. Push the right hinge [A] to release.

6. Front cover [B]

Left Cover

1. Front cover (p.23)

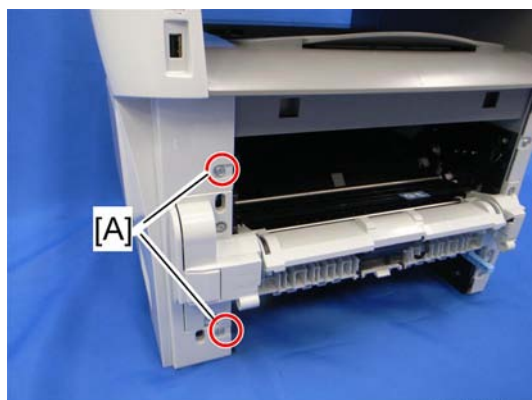

m016i502b

2. Remove two screws [A] on the left cover.



m016r688

3. Pull the front upper part [A] of the left cover (as shown above) to release the hooks.



m016r689

4. Pull the rear upper part [A] of the left cover (as shown above) to release the hooks.

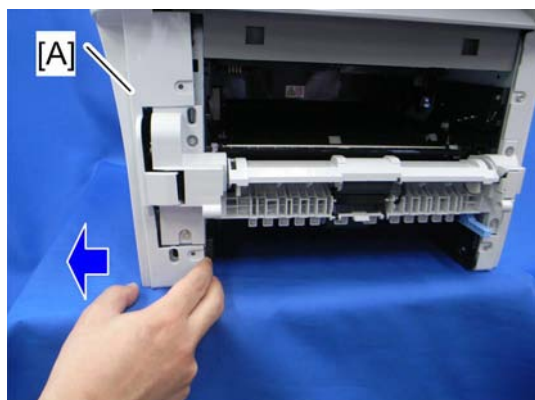

m016r690

4

5. Pull the front bottom part of the left cover [A] (as shown above) to release the hooks.

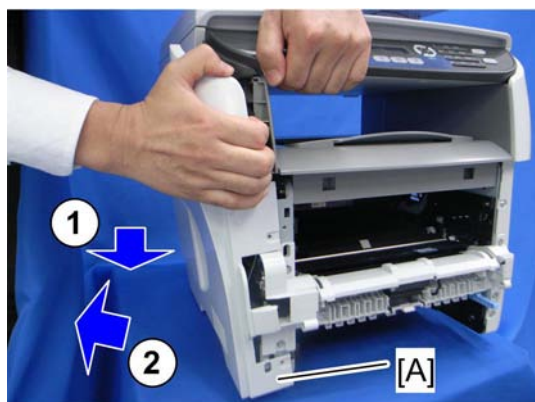

m016r691

6. Remove the Left cover [A] as shown above.
- There are many hooks and tabs inside the left cover. See the images below in the Note section before removing the left cover.

NOTE:

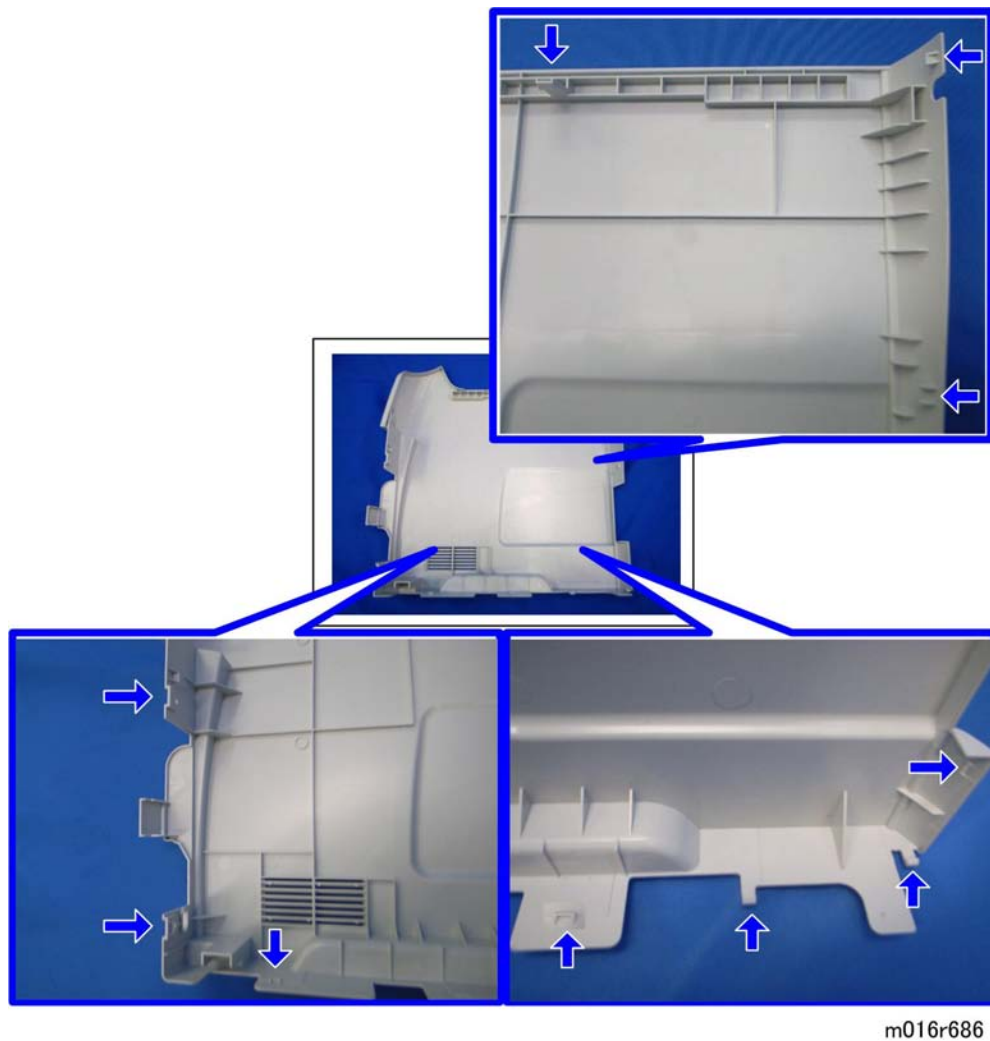

4

Rear Cover

1. Front cover (☛ p.23)
2. Left cover (☛ p.24)



3. Open the rear cover [A]
4. Slide the shaft [B] in the direction of the blue arrow, and remove the rear cover [A].

4

Right Cover

1. Front cover (☛ p.23)
2. Rear cover (☛ p.27)

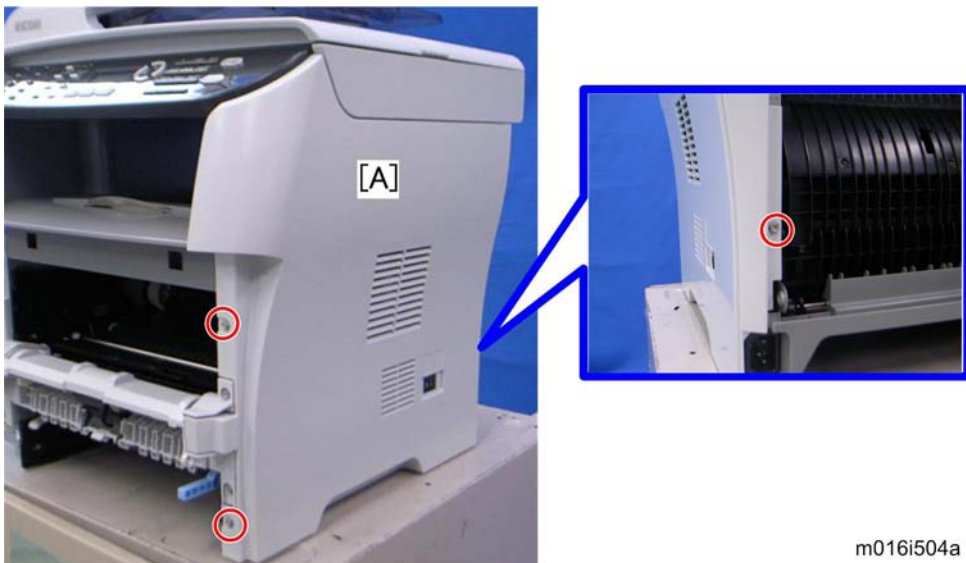

3. Right cover [A] (☛ x 3, hook at arrow mark)
 - There are many hooks and tabs inside the right cover. See the images below in the Note section before removing the right cover.

NOTE:

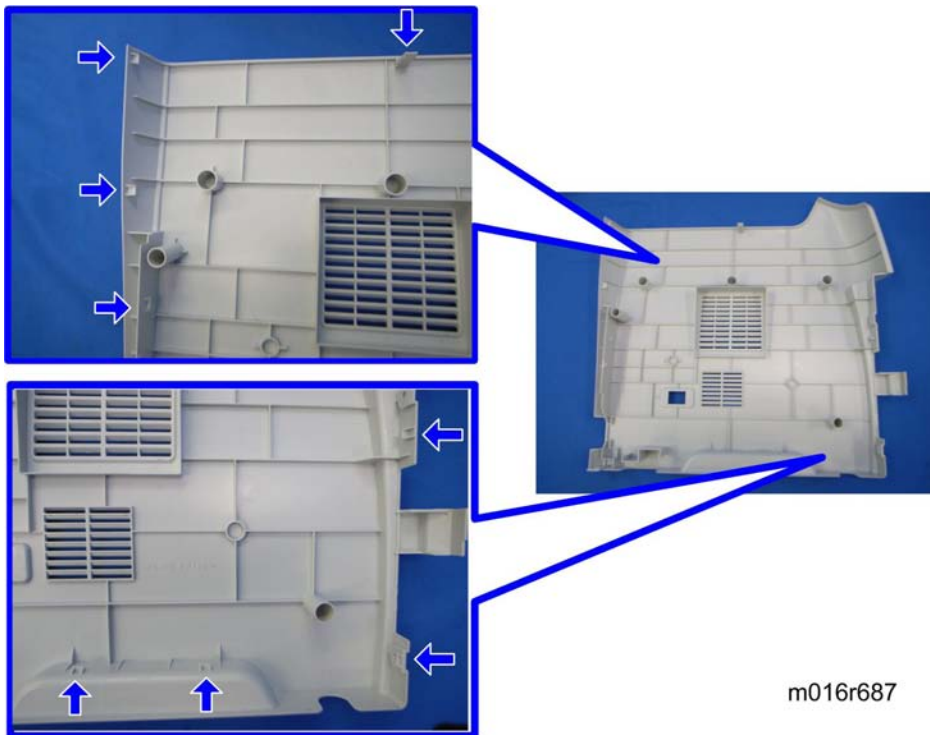

4

Top Cover

1. Front cover (☛ p.23)
2. Left cover (☛ p.24)
3. Rear cover (☛ p.27)
4. Scanner unit (☛ p.40)

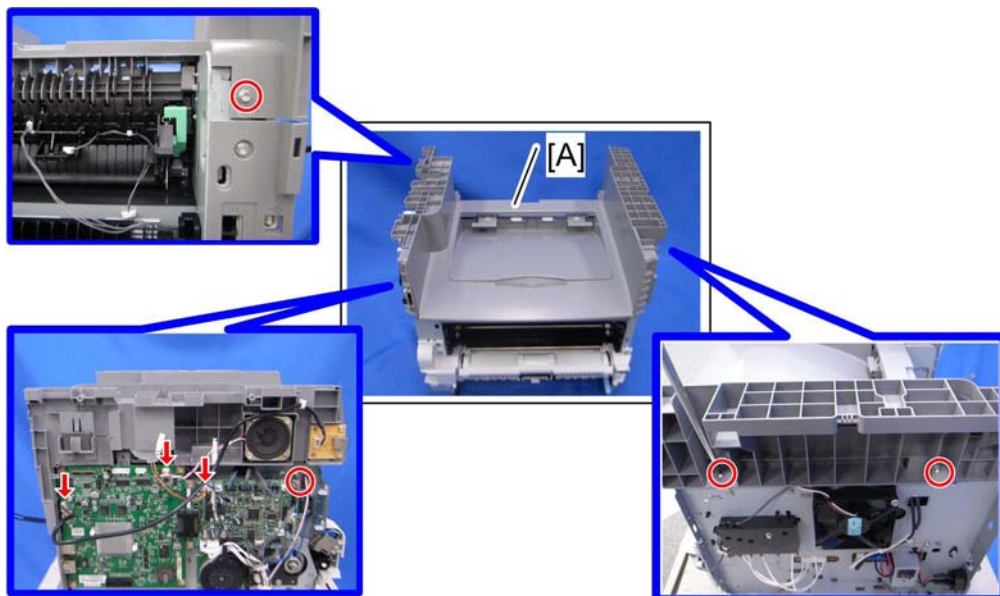

m016i506

4

5. Top cover [A] (🔧 x 3, 🔧 x 4)

When installing the top cover

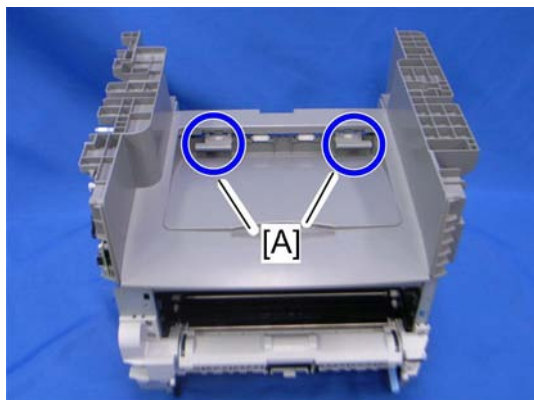

m016r685

- When re-installing the top cover, always verify that the two paperweights [A] are lifted. If they are not lifted to fit into the paper slot, the paperweights [A] could be damaged.
- Make sure that these paperweights [A] can be moved smoothly (up and down) after installing the top cover. If these paperweights do not move smoothly, try installing the top cover again.

ADF

ADF Unit

1. Left cover (☛ p.24)

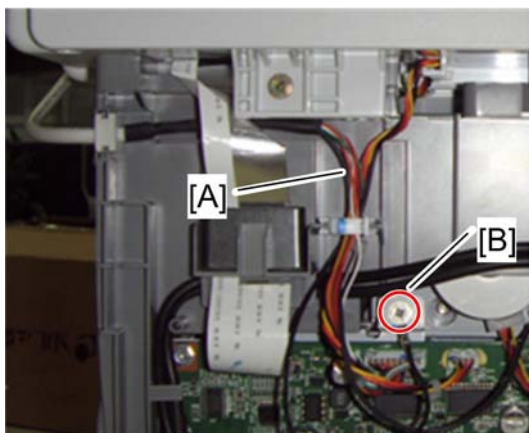

m016r100

2. Disconnect the ADF harness [A] and ground-wire [B] (☛ x 1).



m016r674

3. Open the ADF unit [A]

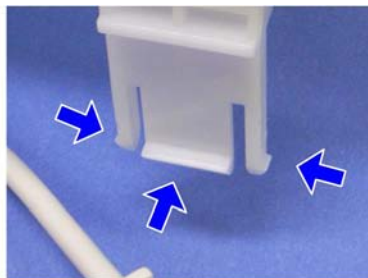
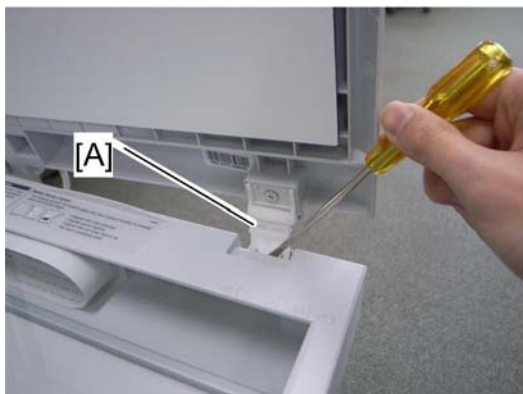

m016r675

4

4. Release the three hooks of the right hinge [A] with a screw driver, as shown above.
5. Lift the ADF unit.

Original Tray

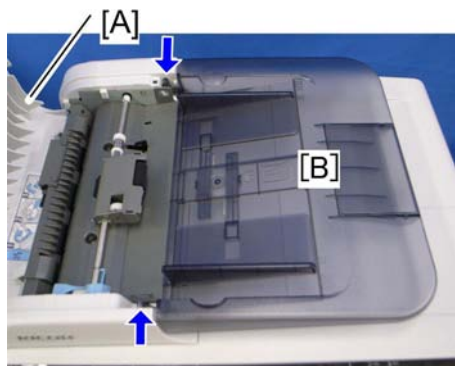

m016r101

1. Open the ADF cover [A].
2. Original tray [B] (Two tabs)

ADF Feed Unit

1. Open the ADF cover.

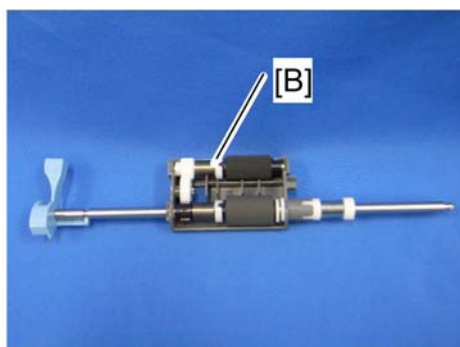
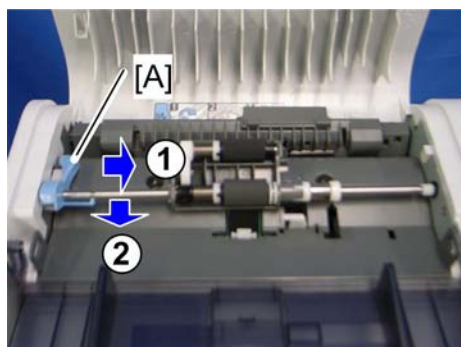

m016r102

2. Release the lock lever [A]
3. ADF feed unit [B]

4

ADF Separation Pad

1. Open the ADF cover.
2. ADF feed unit (☛ p.32)

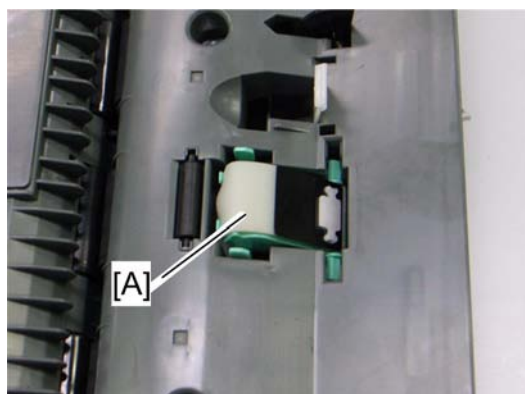

m018r661

3. ADF separation pad [A] (hook x 2, spring x 1)

ADF Front Cover

1. ADF unit (☛ p.31)
2. Original Tray (☛ p.32)
3. ADF feed unit (☛ p.32)

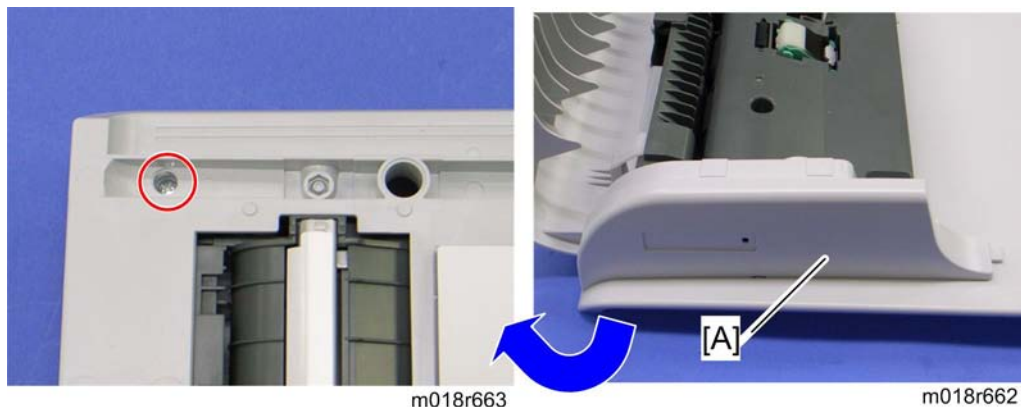

m018r663

m018r662

4

4. ADF front cover [A] (🔩 x 1)

ADF Rear Cover

1. ADF unit (🔩 p.31)
2. Original Tray (🔩 p.32)
3. ADF feed unit (🔩 p.32)

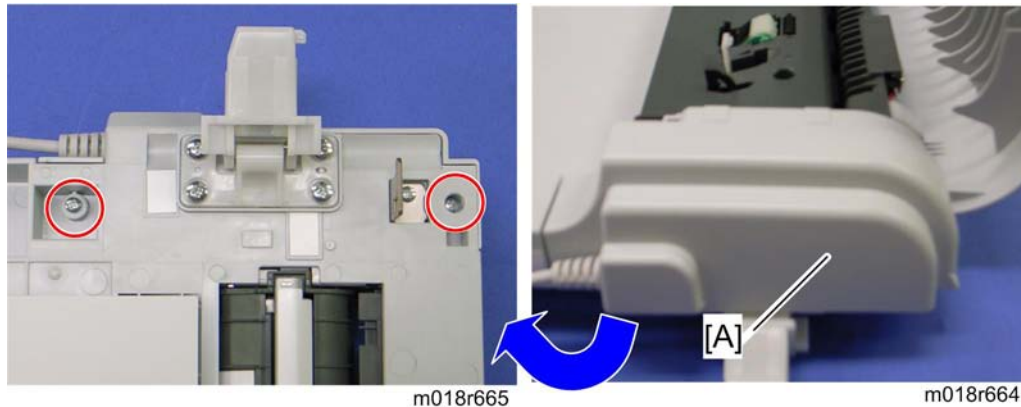

m018r665

m018r664

4. ADF rear cover [A] (🔩 x 2)

ADF Cover

1. ADF unit (🔩 p.31)
2. ADF front cover (🔩 p.33)
3. ADF rear cover (🔩 p.34)

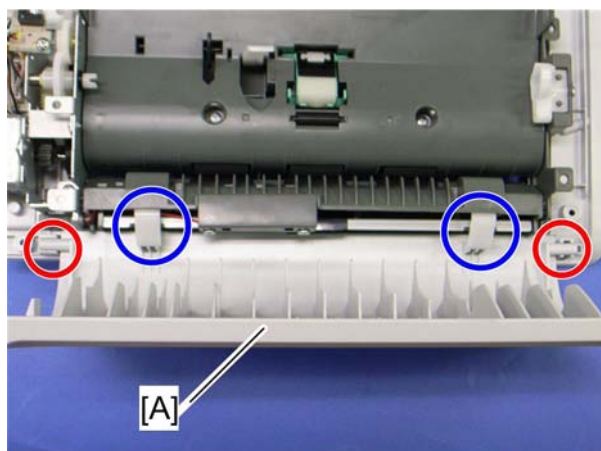

m018r666

4. ADF top cover [A] (two tabs, two hooks)

4

ADF Motor

1. ADF unit (☛ p.31)
2. Original Tray (☛ p.32)
3. ADF feed unit (☛ p.32)
4. ADF front cover (☛ p.33)
5. ADF rear cover (☛ p.34)

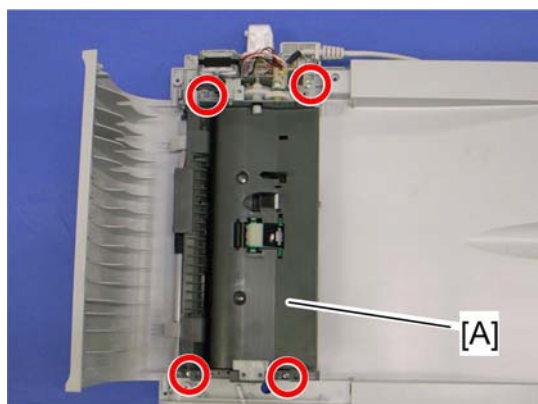

m018r667

6. ADF drive unit [A] (☛ x 4, all ☛s)

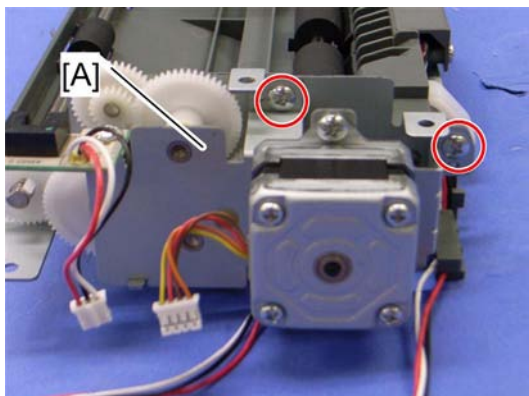

m016r668

4

7. ADF motor assembly [A] (🔧 x 2)

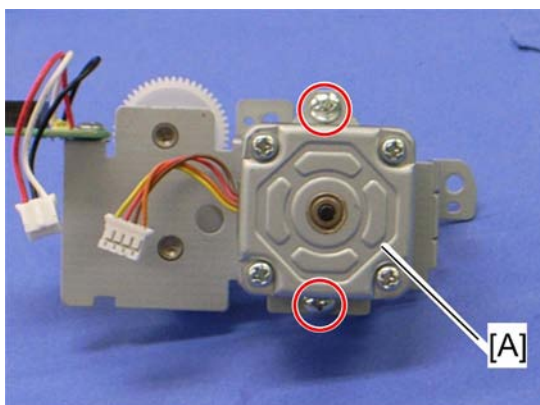

m016r669

8. ADF motor [A] (🔧 x 2)

Original Set Sensor

1. ADF unit (🔧 p.31)
2. ADF feed unit (🔧 p.32)
3. ADF motor assembly (🔧 p.35)

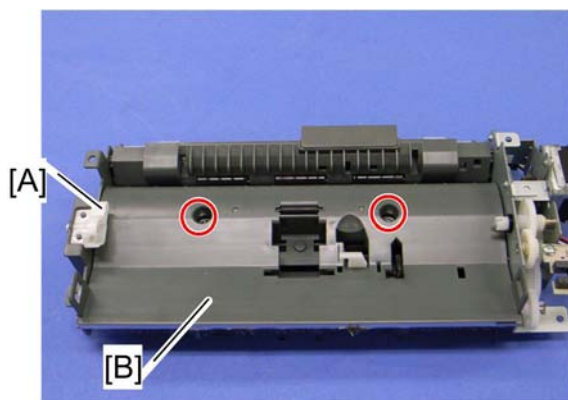

m018r670

4. Feed roller holder [A] (🔩 x 1)
5. Upper guide [B] (🔩 x 2)

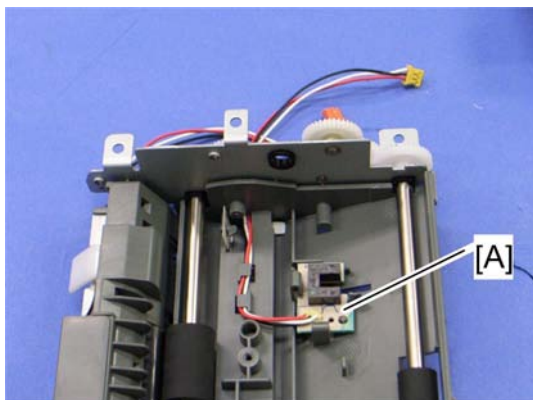

m016r671

6. Original set sensor [A] (hooks)

ADF Cover Open Sensor

1. Original tray (🔧 p.32)
2. ADF rear cover (🔧 p.34)

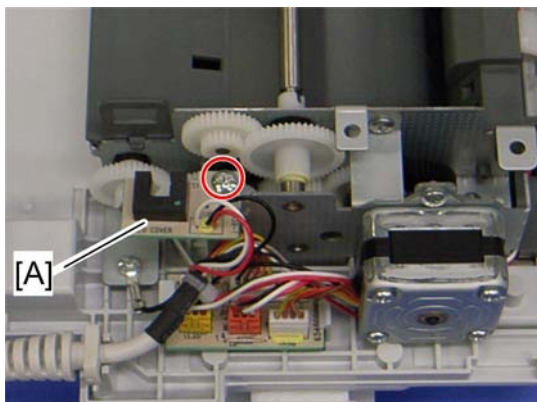

m018r679

4

3. ADF cover open sensor [A] (🔩 x 1, 📡 x 1)

ADF Feed Sensor

1. ADF unit (🔗 p.31)
2. ADF feed unit (🔗 p.32)

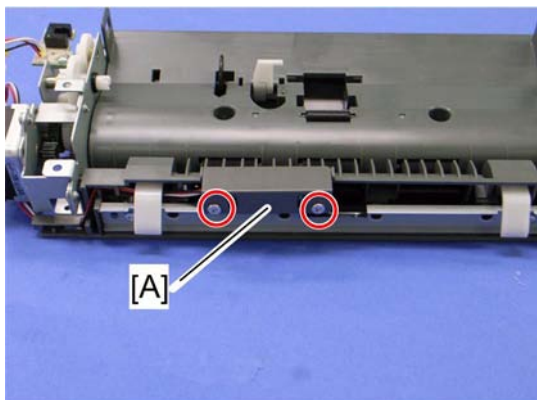

m018r680

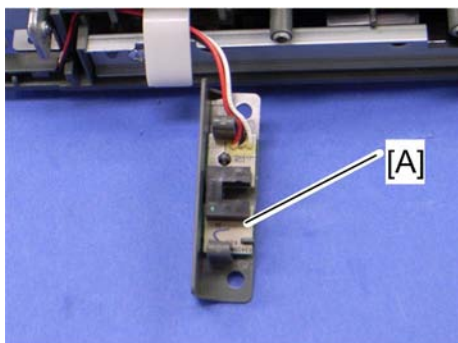

3. Sensor cover [A] (🔩 x 2)



m016r681

4. ADF feed sensor [A] (hooks,  x 1)

ADF Drive Board

1. Original tray ( p.32)
2. ADF rear cover ( p.34)

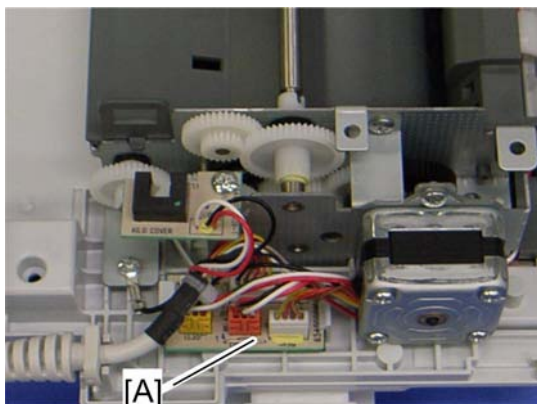

m018r679a

3. ADF drive board [A] (no screws, all plugs (s and hooks)

Scanner Unit

1. Front cover (☛ p.23)
2. Left cover (☛ p.24)
3. Rear cover (☛ p.27)

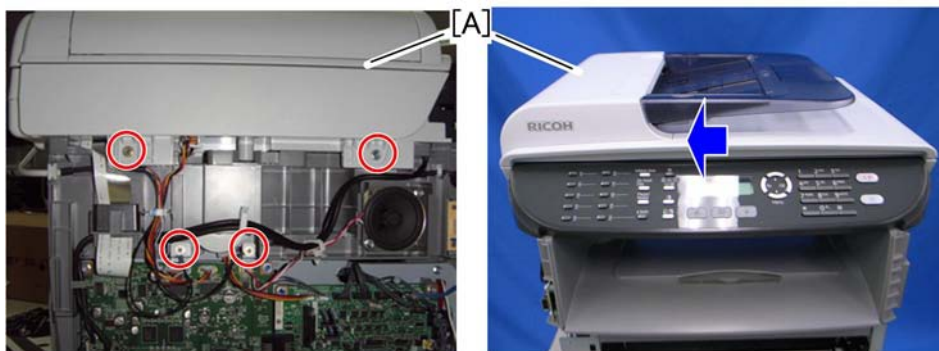

m016r505

4. Slide the scanner unit [A] in the direction of the blue arrow, and remove it (⚙ x 4, ground cable x 2, flat cable x 1, ☛ x 3, ☛ x 3).
5. ADF unit (☛ p.31)
6. Operation Panel (☛ p.40)

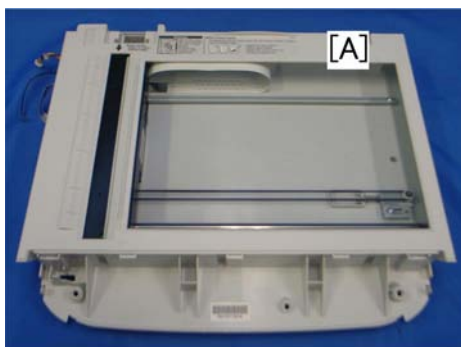

m016r103

7. Scanner Unit [A]

Operation Panel

1. Scanner unit (☛ p.40)
2. ADF unit (☛ p.31)

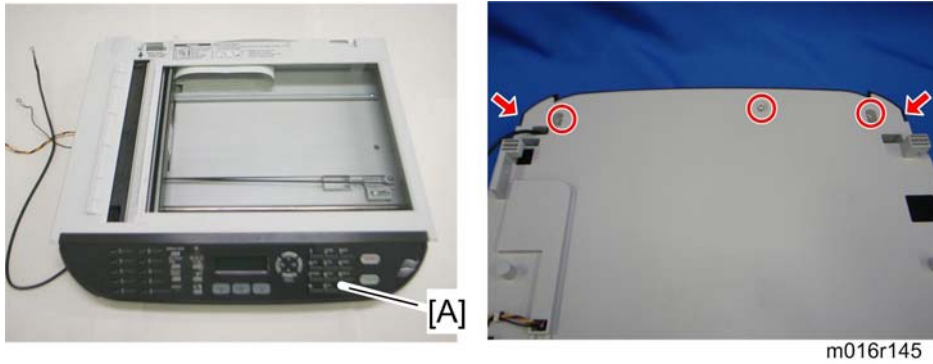

3. Turn the scanner unit over.
4. Operation panel [A] (🔧 x 3, hooks)

4

Scanner Top Cover

1. Scanner unit (🔧 p.40)
2. Turn the scanner unit over.

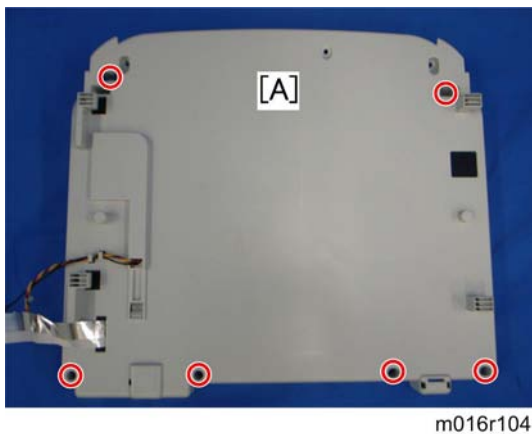

3. Remove the six screws on the bottom of the scanner base [A].

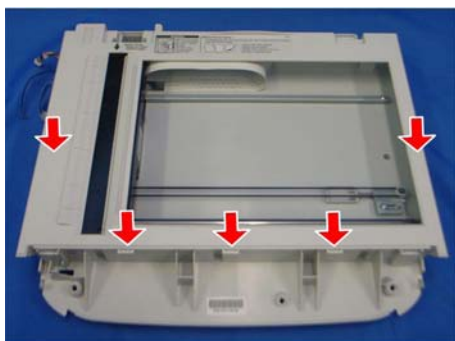

m016r105

4. Scanner top cover [A] (hooks)

4

Scanner Carriage Unit

1. Scanner unit (☛ p.40)
2. Scanner top cover (☛ p.41)

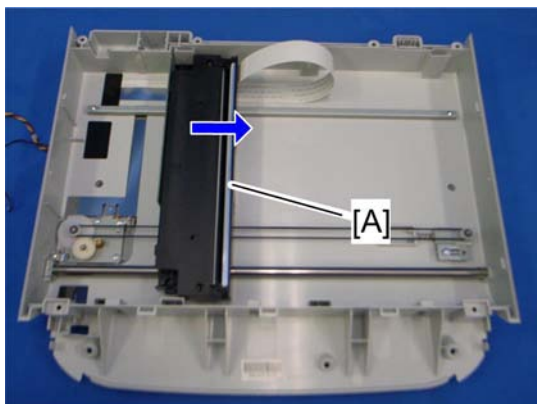

m016r106

3. Slide the scanner carriage unit [A] to the right side.

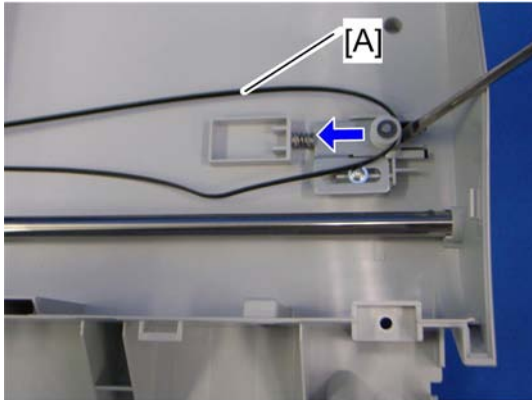

m016r107

4. Loosen the timing belt [A] as shown above, and remove it.

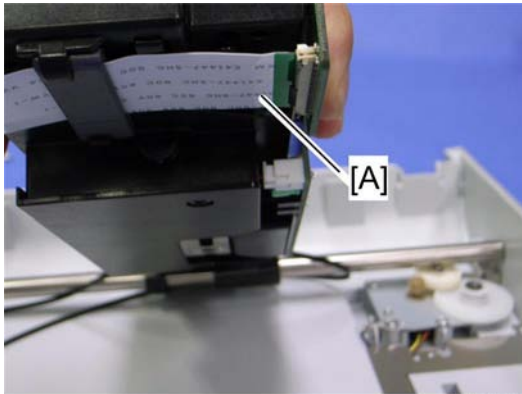

m016r644

5. Remove the flat cable [A] from the scanner carriage unit.

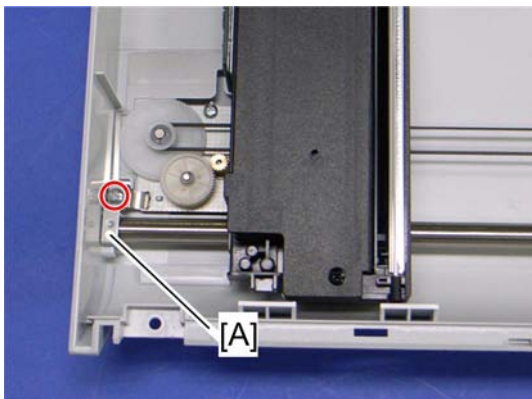

m016r645

6. Bar holder [A] (🔧 x 1)

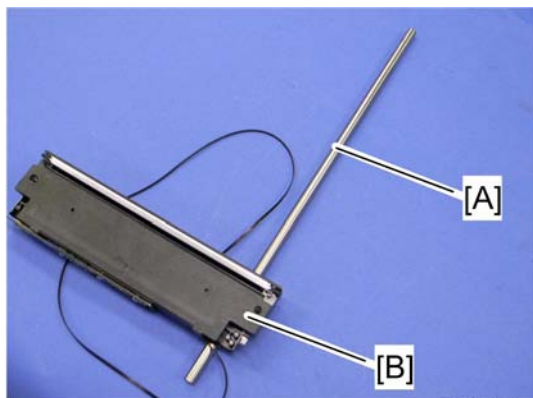

m016r646

4

7. Carriage bar [A] and scanner carriage unit [B]

Exposure Lamp

1. Scanner carriage unit (☛ p.42)

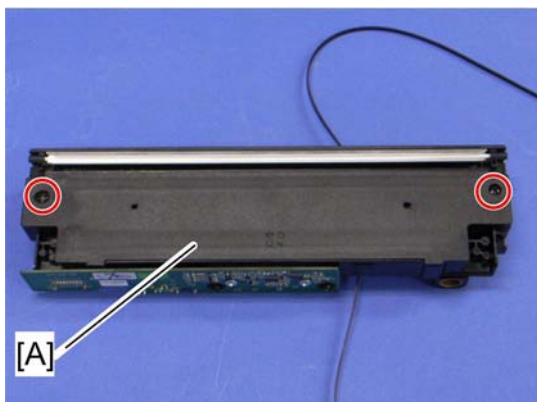

m018r647

2. Carriage top cover [A] (🔩 x 2, 📏 x 1)

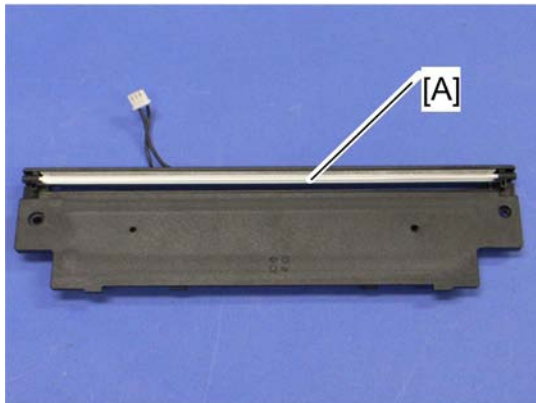

m016r648

3. Exposure lamp [A] (hooks)

4

When reinstalling the exposure lamp



m016r649

Place the lamp cord wires as shown above. Otherwise, the top cover could pinch the lamp cords and damage them when reinstalling the top cover on the scanner carriage unit.

Lamp Stabilizer Board

1. Scanner carriage unit

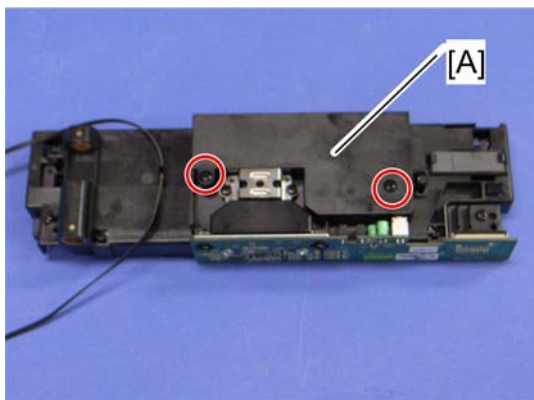

m018r650

4

2. Carriage bottom cover [A] (🔩 x 2)

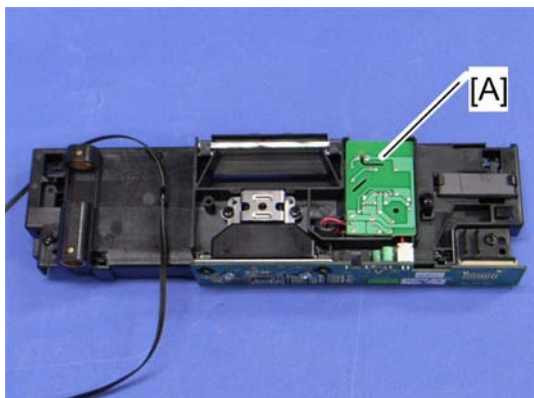

m016r651

3. Lamp stabilizer [A] (🔧 x 1)

Scanner Motor

1. Scanner carriage unit (🔧 p.42)

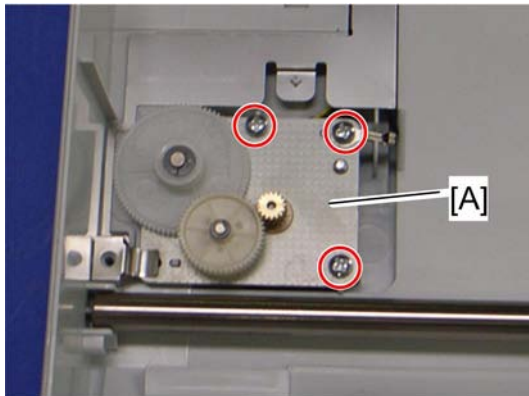

m018r652

2. Scanner motor [A] (⚙️ x 3)

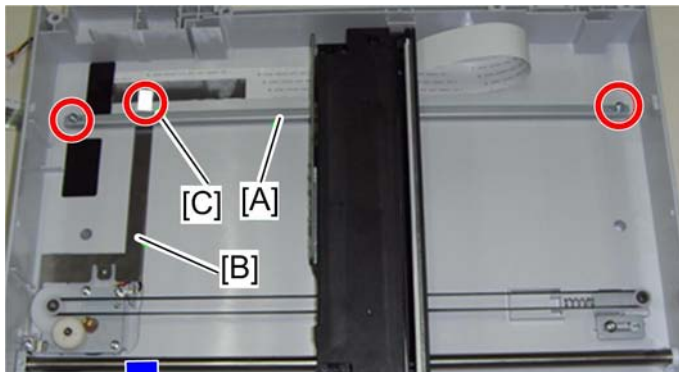

m016r653

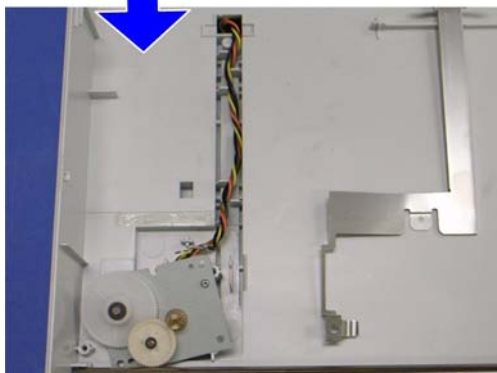

3. Carriage rail [A] (⚙️ x 2)
4. Ground plate [B] (double-sided tape)
5. Conductance tape [C]
6. Scanner motor

Laser Unit

⚠ CAUTION

- Turn off the main power switch and unplug the machine before attempting any of the procedures in this section. Laser beams can seriously damage your eyes.

Caution Decal Locations

Caution decal is attached as shown below.

4

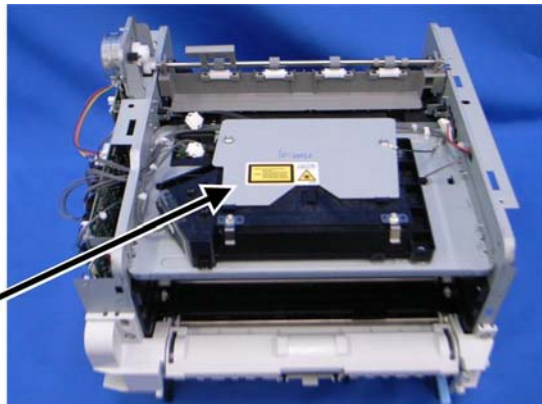

m016i509

⚠ WARNING

- Be sure to turn off the main switch and disconnect the power plug from the power outlet before beginning any disassembly or adjustment of the laser unit. This machine uses a class IIIB laser beam with a wavelength of 648 to 663 nm and an output of 9 mW. The laser can cause serious eye injury.

Laser Unit

1. Front cover (🔧 p.23)
2. Left cover (🔧 p.24)
3. Rear cover (🔧 p.27)
4. Scanner unit (🔧 p.40)
5. Top cover (🔧 p.29)



m016i508

6. Laser unit [A] (⚙️ x 3, ground screw x 3, 📡 x 2)

4

Polygon Mirror Motor

⚠️ CAUTION

- Turn off the main switch and unplug the machine before attempting any of the procedures in this section. Laser beams can seriously damage your eyes.

1. Laser unit (🔍 p.48)

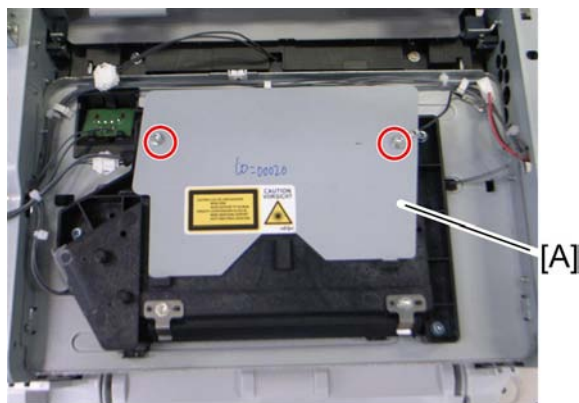

m016r149

2. Polygon mirror cover [A] (⚙️ x 2)

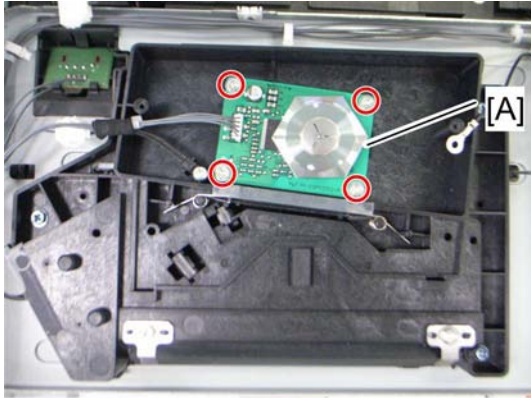

m016r150

4

3. Polygon mirror motor [A] (🔩 x 4, 📦 x 1)

⬇️ **Note**

- Never touch the surface of the mirror with bare hands.

Paper Feed and Exit

Paper Feed Roller

1. Pull out the standard paper tray.
2. Remove the AIO.



m016r127

3. Set the machine with the rear side facing down, resting on the table.

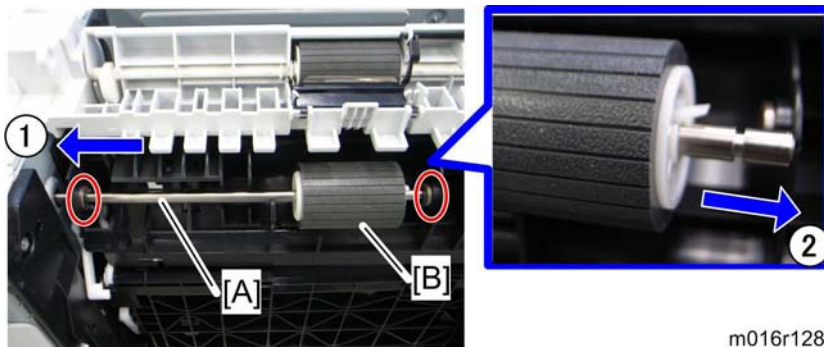

m016r128

4. Slide the paper feed shaft [A] to the left side (☞ x 2).
5. Slide the paper feed roller [B] to right side, and remove it (hook).

After installing a new paper feed roller

1. Enter the "Maintenance Mode".
2. Select "Engine Maintenance", and then press "OK" key.
3. Select "Reset Paper Feed Life" and then press "OK" key.
4. Select "Execute" and then press "OK" key.

Friction Pad

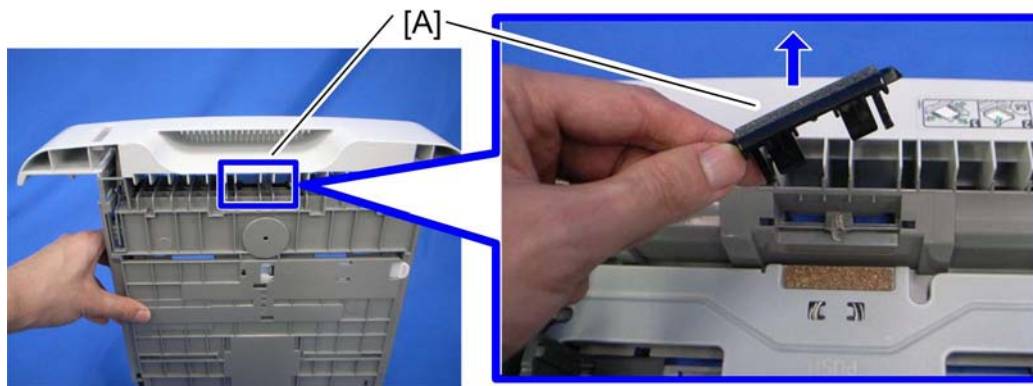

m016r682

1. Remove the paper tray unit from the machine before removing the friction pad.
2. Friction pad [A] (2 hooks, 1 spring)

When reinstalling the friction pad follow this order:

1. Replace the spring.
2. Insert the right side of the friction pad first, followed by the left side.
3. Gently push the friction pad down into the slot and then pull forward very slightly.

Paper End Sensor

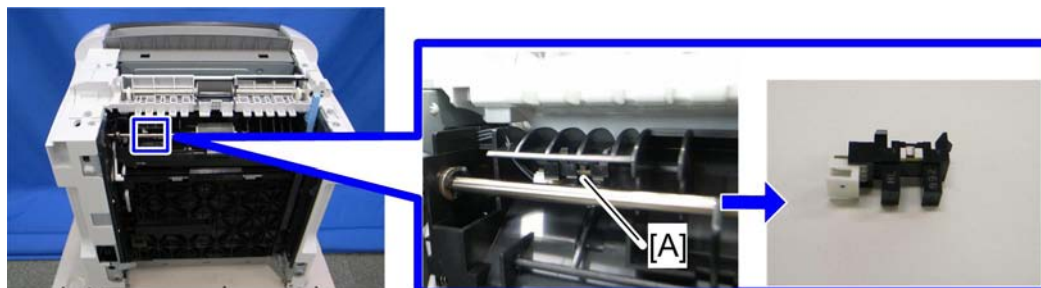

m016r151

1. Set the machine with the rear side facing down, resting on the table.
2. Paper end sensor [A] (hooks,  x 1)

By-pass Feed Roller

1. Front cover ( p.23)

2. Left cover (☛ p.24)
3. Right cover (☛ p.28)
4. Pull out the paper tray.

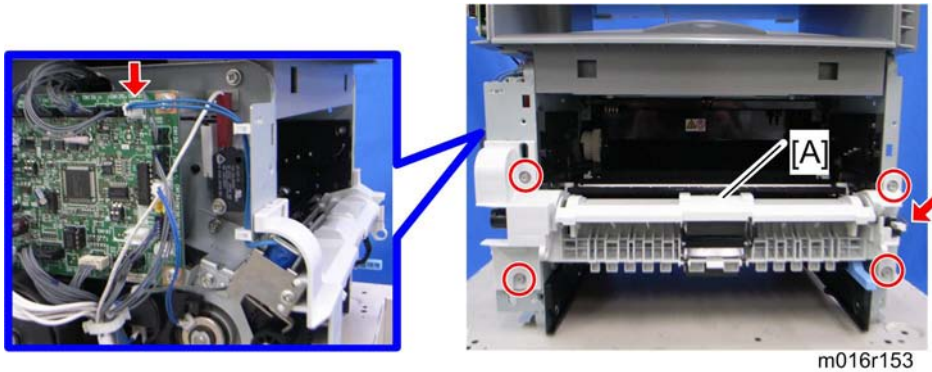

m016r153

5. By-pass lower guide plate [A] (☛ x 4, ☛ x 2)

NOTE:

- Reinstall the by-pass lower guide plate [A] while pressing the spring [B].
- Be careful for the spring [B] and the ground plate [C] not to fall inside the machine during reinstallation.

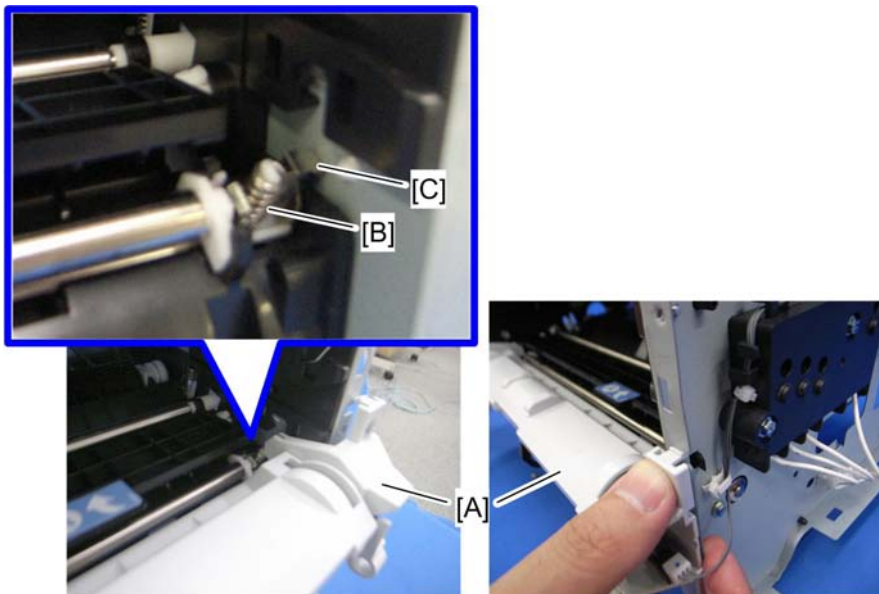

m016r703

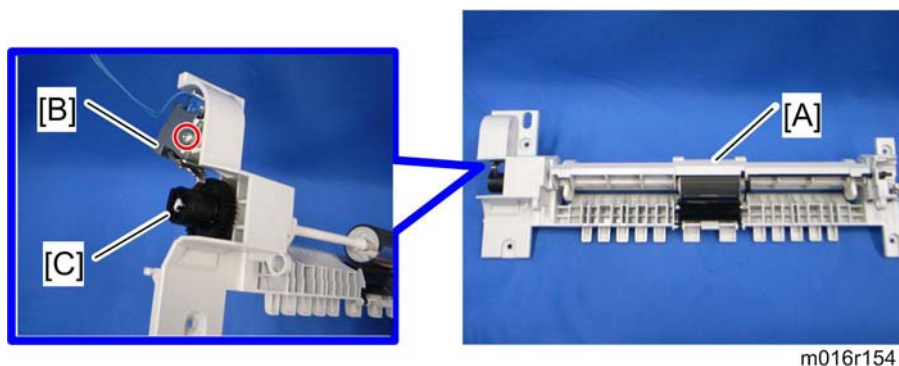

4

6. By-pass upper guide plate [A] (hooks)
7. By-pass solenoid cover, by-pass solenoid [B] (⌀ x 1)
8. Gear [C] (hook)

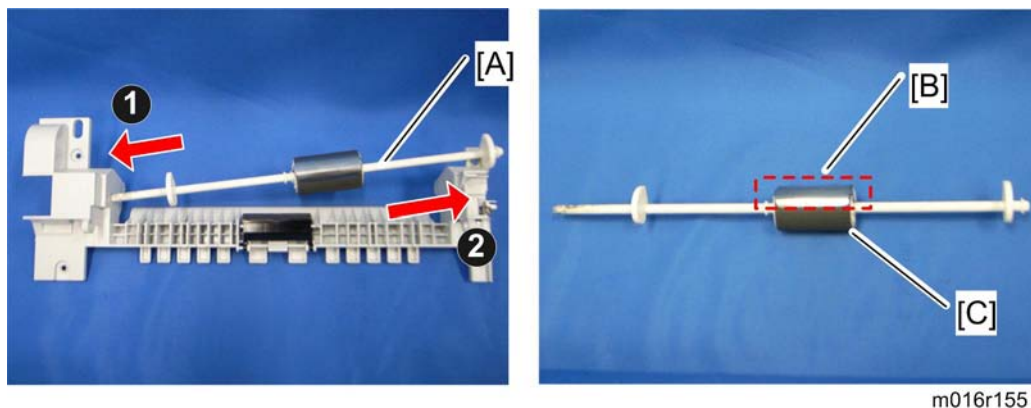

9. Slide the by-pass feed roller shaft [A] to the left side, and remove it.
10. Remove the metal cover [B] from the by-pass feed roller [C].

By-Pass Feed Roller Friction Pad

1. By-pass feed roller (⌀ p.52)

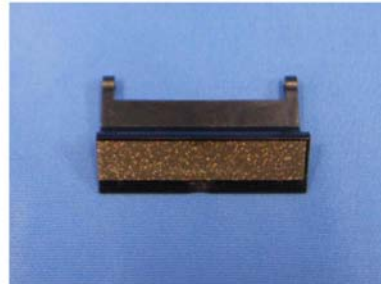
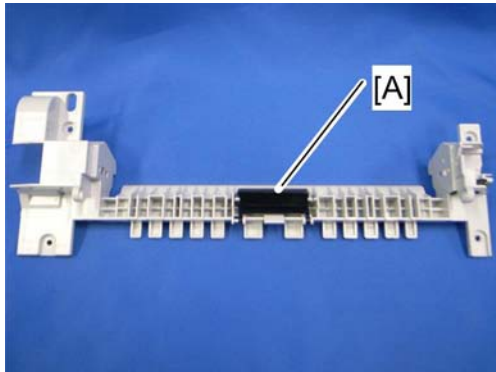

m016r156

2. By-pass feed roller friction pad [A] (hooks, spring x 1)

4

By-pass Feed Sensor

1. Front cover (🔧 p.23)
2. Right cover (🔧 p.28)

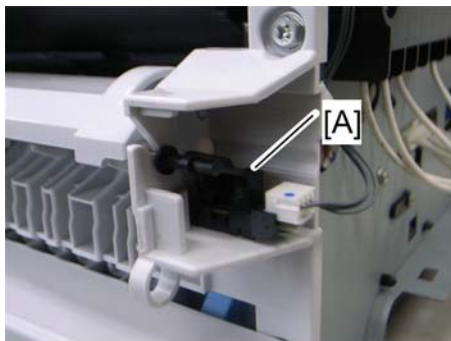

m016r152

3. By-pass feed sensor [A] (hooks, 📧 x 1)

Paper Feed Clutch

1. Top cover (🔧 p.29)
2. Scanner unit (🔧 p.40)
3. ECB (🔧 p.74)
4. Controller board (🔧 p.76)
5. FCU (🔧 p.77)

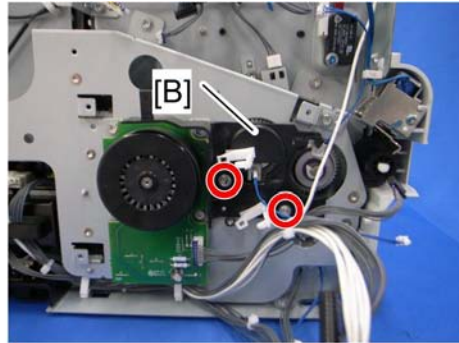
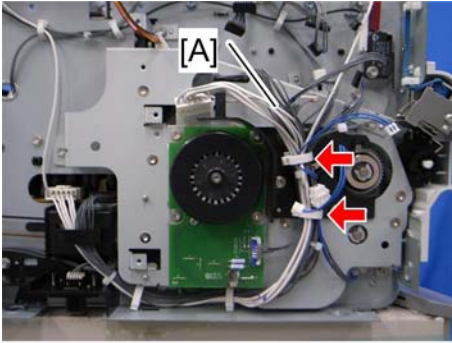

m016r109

4

- 6. Release all harnesses [A] from the clamps.
- 7. Harness guide plate [B] (🔩 x 2)

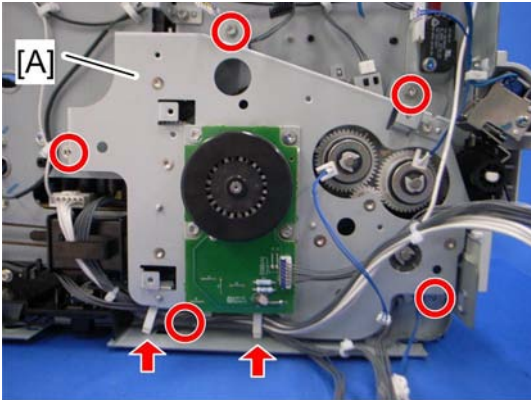

m016r704

- 8. Drive unit [A] (🔩 x 5, 📦 x 1, 📦 x 2, timing belt)

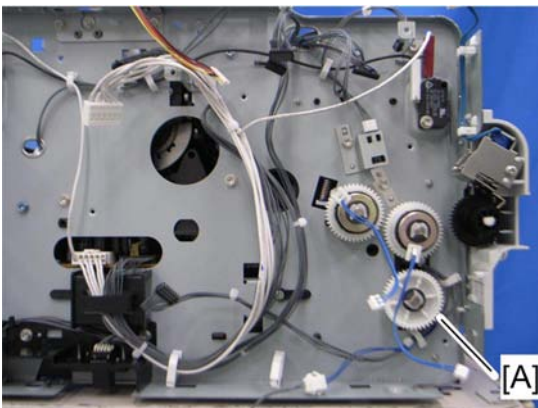

m016r113

- 9. Paper feed clutch [A] (📦 x 1, 📦 x 1)

Relay Clutch

1. Drive unit (☛ p.55 "Paper Feed Clutch")

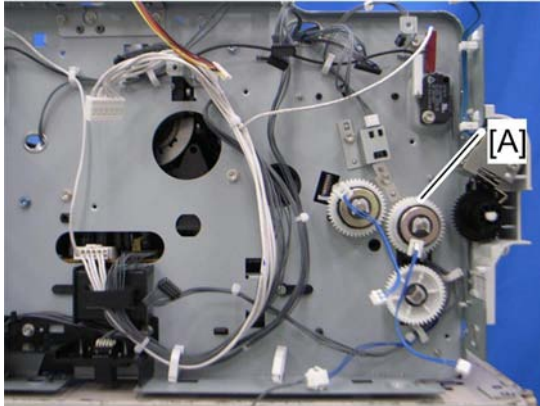

m016r111

2. Relay clutch [A] (☞ x 1)

Registration Clutch

1. Drive unit (☛ p.55 "Paper Feed Clutch")

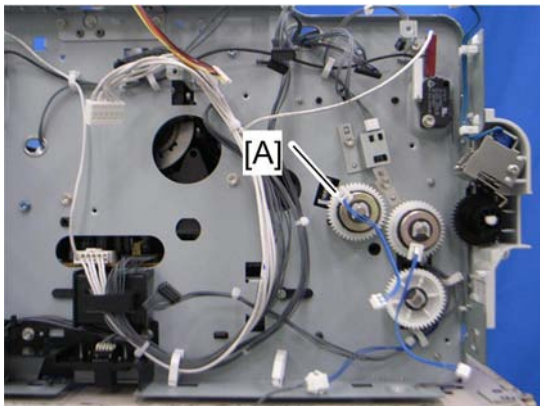

m016r112

2. Registration clutch [A] (☞ x 1)

Toner End Sensor

1. Drive unit (☛ p.55 "Paper Feed Clutch")

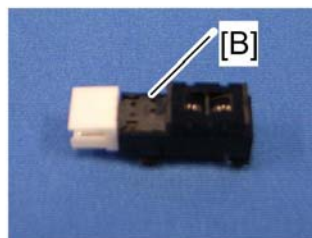
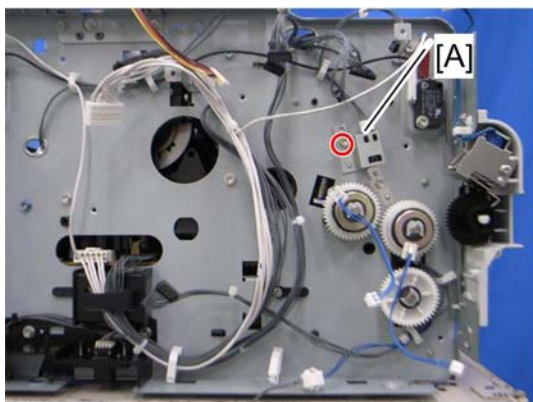

m016r147

4

2. Reflective sensor with bracket [A] (🔧 x 1)
3. Reflective sensor [B]

Paper Exit Sensor

1. Rear cover (🔧 p.27)

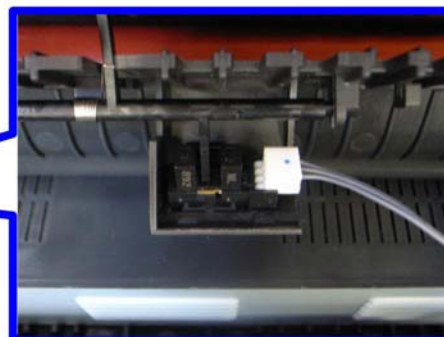
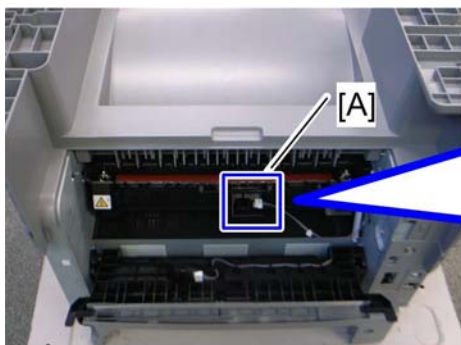

m016r158

2. Paper exit sensor [A] (🔧 x 1, hooks)

Relay Sensor

1. Rear cover (🔧 p.27)



m016r159

2. Relay sensor [A] (🔧 x 1, hooks)

Inverter Sensor

1. Duplex transport guide (🔧 p.78 "PSU")

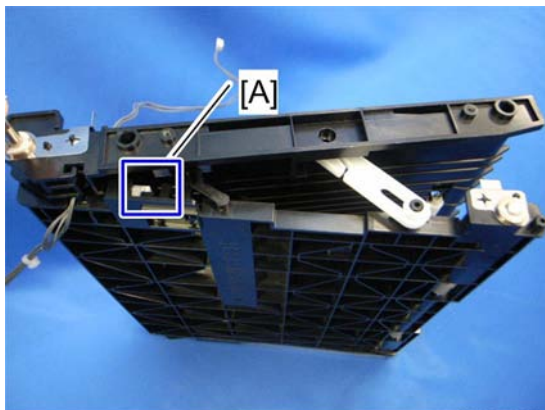

m016r160

2. Inverter sensor [A] (🔧 x 1, hooks)

Registration Roller and Sensor

1. Pull out the paper tray.
2. PSU (🔧 p.78 "PSU")
3. Paper feed clutch (🔧 p.55 "Paper Feed Clutch")
4. Relay clutch (🔧 p.57)
5. Registration clutch (🔧 p.57)

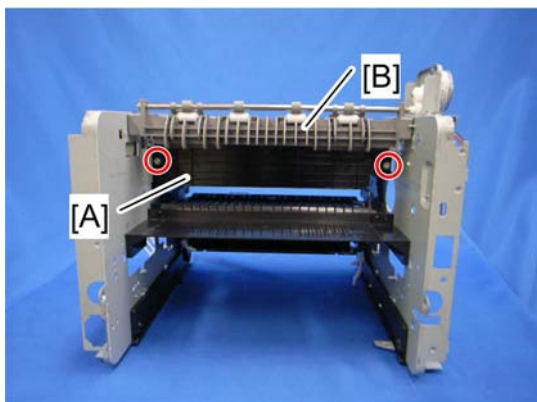

m016r696

4

- 6. Heat insulating plate [A] (⌀ x 2)
- 7. Exit roller base [B] (⌀ x 2)

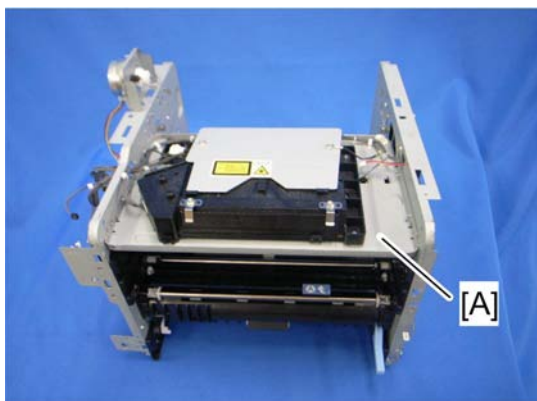

m016r694

- 8. Imaging unit base [A] (⌀ x 4)

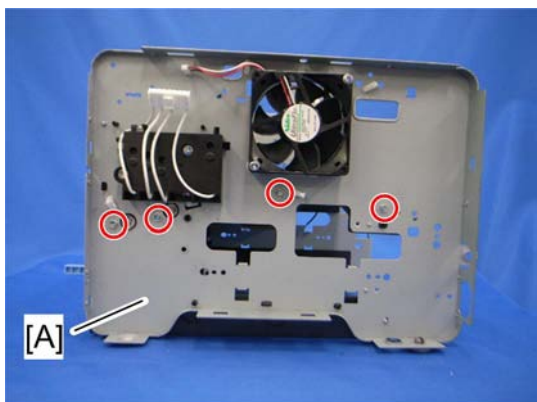

m016r697

- 9. Remove the four screws in the right frame [A].

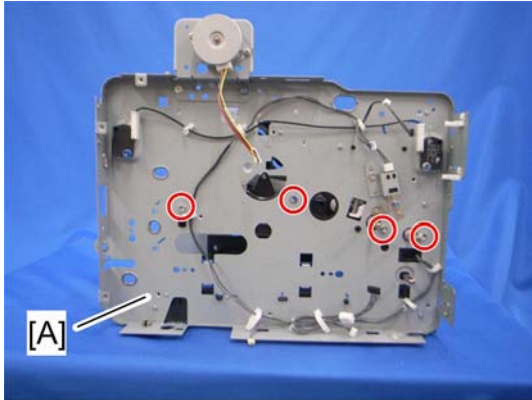

m016r698

10. Remove the four screws in the left frame [A].

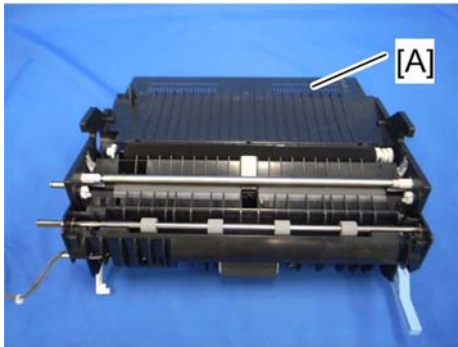

m016r699

11. Registration unit [A]
12. Upper guide plate [B]

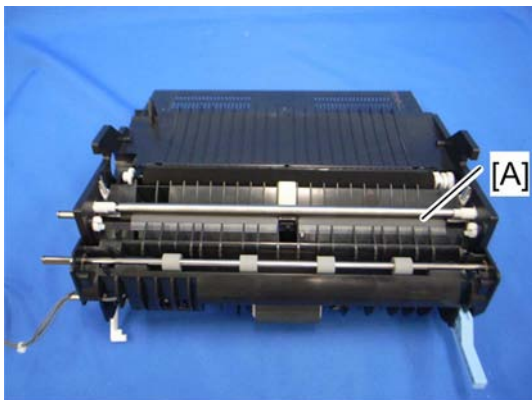

m016r700

13. Registration roller [A]

4

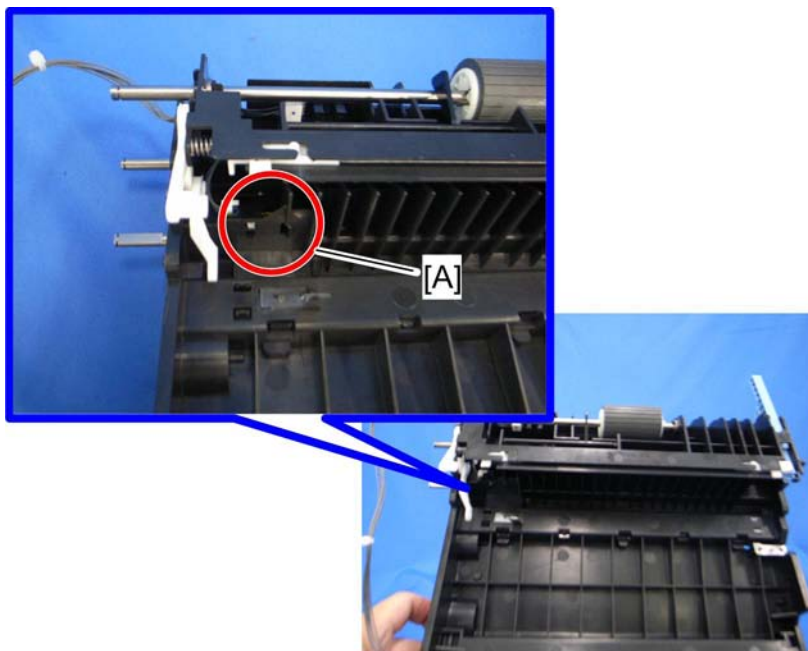

m016r701

14. Registration sensor [A]

Paper Transfer

Transfer Roller

1. Front cover (☛ p.23)
2. Remove the AIO.

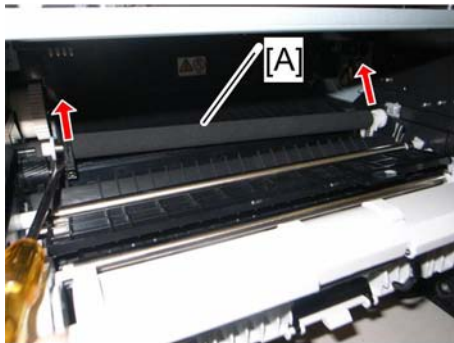

m016r146

3. Remove the transfer roller [A] (Bushing x 1, spring x 2, gear x 1) as shown above.

↓ Note

- Do not touch the transfer roller surface, when reinstalling the new transfer roller.

After installing a new transfer roller

1. Enter the "Maintenance Mode".
2. Select "Engine Maintenance", and then press "OK" key.
3. Select "Reset Transfer Roller Life" and then press "OK" key.
4. Select "Execute" and then press "OK" key.

Fusing

⚠ CAUTION

- Switch off the main power, unplug the machine from its power source, and allow the fusing unit to cool before removing it.

Fusing Unit

1. Front cover (🔧 p.23)
2. Left cover (🔧 p.24)
3. Rear cover (🔧 p.27)

4

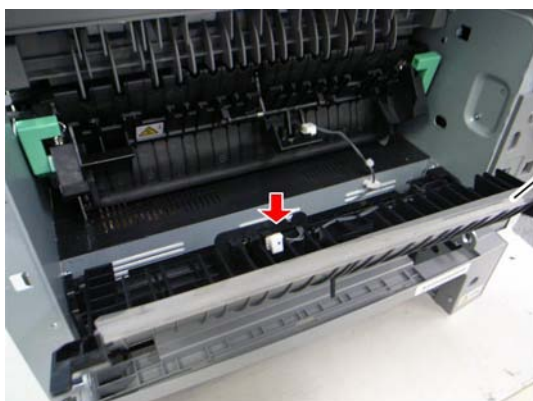

m016r169

4. Entrance guide [A] (🔧 x 1)

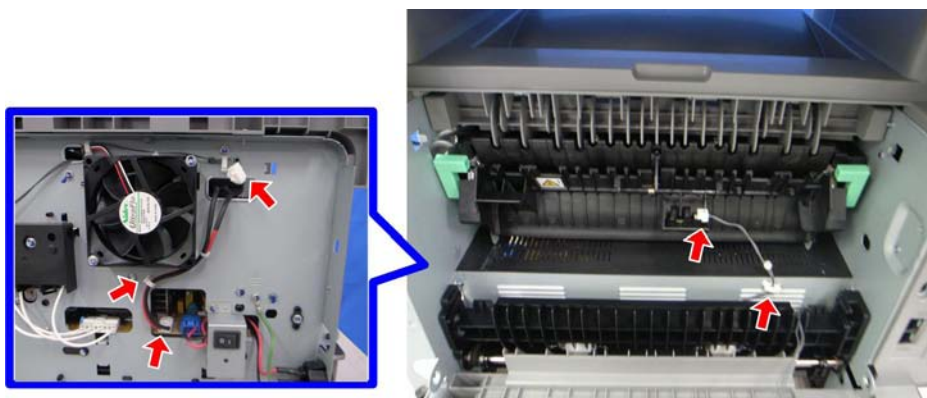

m016r130

5. Disconnect the three harnesses (🔧 x 2)

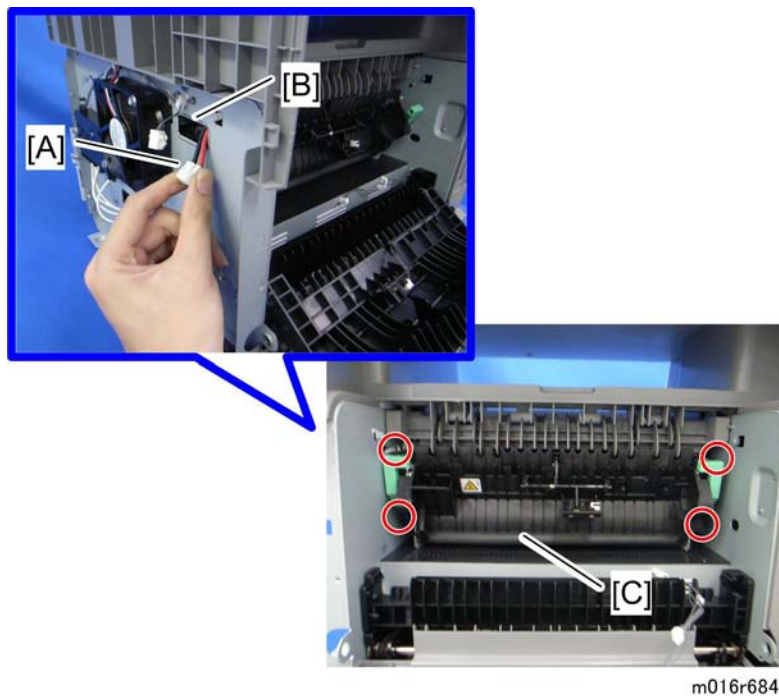

6. Pass the cable [A] through the hole [B] inside the machine.
7. Fusing unit [C] (x 4)

NOTE:

Make sure that the two bushings [A] remain be setting.

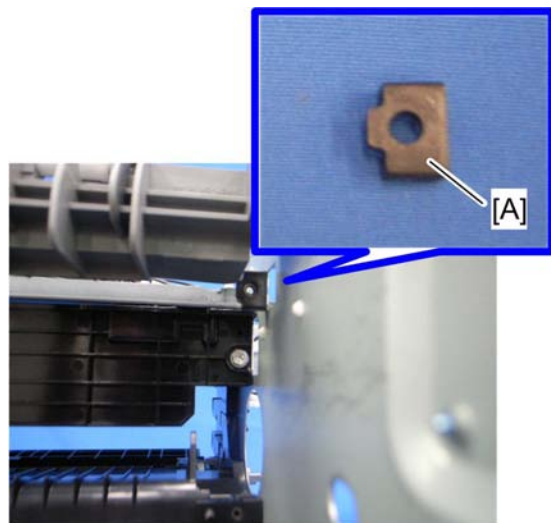

Reinstallation

Pass the cable [A] of fusing unit through the hole [B] outside, after setting the fusing unit.

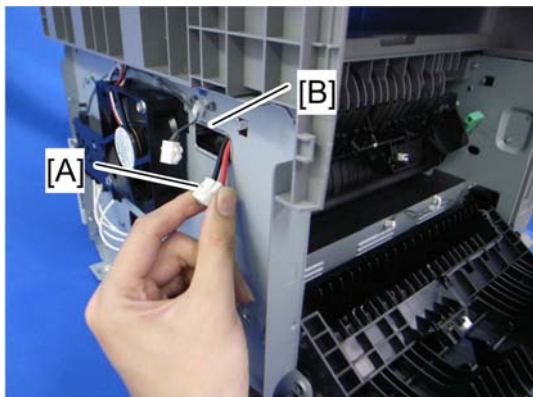

m016r702

4

After installing a new fusing unit

1. Enter the "Maintenance Mode".
2. Select "Engine Maintenance", and then press "OK" key.
3. Select "Reset Fusing Unit Life" and then press "OK" key.
4. Select "Execute" and then press "OK" key.

Thermostat

⚠ CAUTION

- Do not recycle a thermostwitch that is already opened. Safety is not guaranteed if you do this.

1. Fusing unit [A] (🔧 x 3)

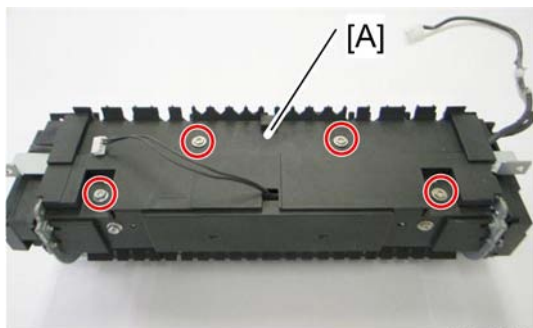

m016r141

2. Fusing upper cover [A] (🔧 x 4)

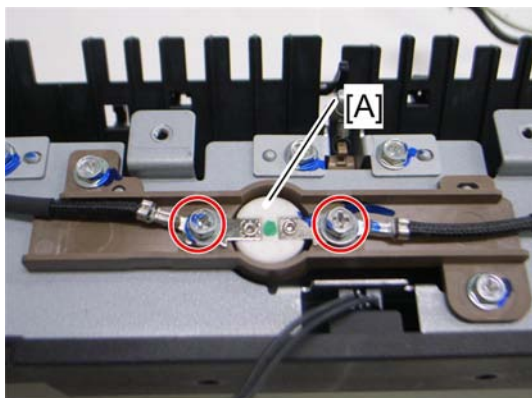

m016r142

3. Thermostat [A] (🔩 x 2)

4

Thermistor

1. Fusing unit (🔌 p.64)

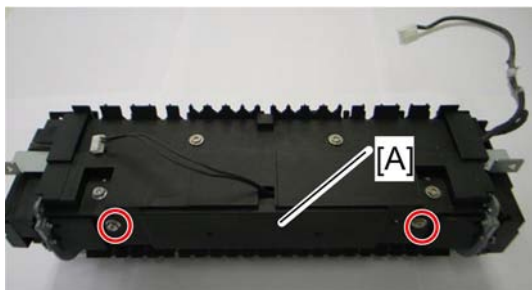

m016r132

2. Fusing front cover [A] (🔩 x 2)

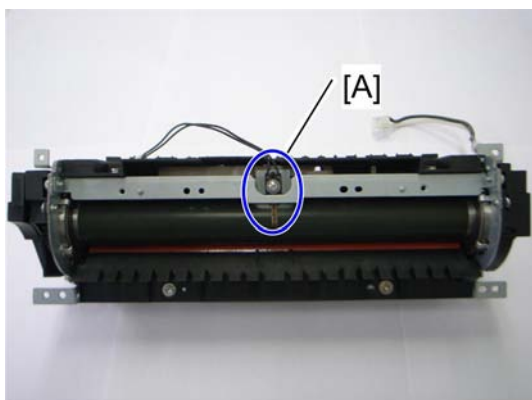

m016r131

3. Thermistor [A] (🔩 x 1)

Fusing Lamp

1. Fusing Unit (☛ p.64)

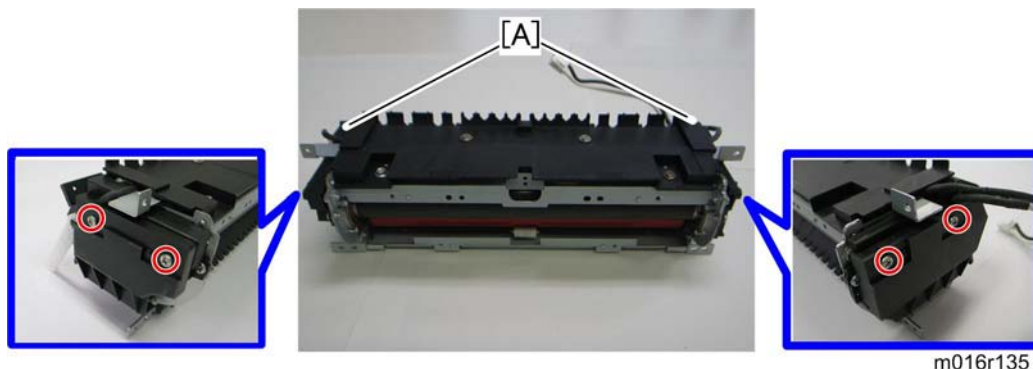

2. Fusing side covers [A] (☛ x 2 each)

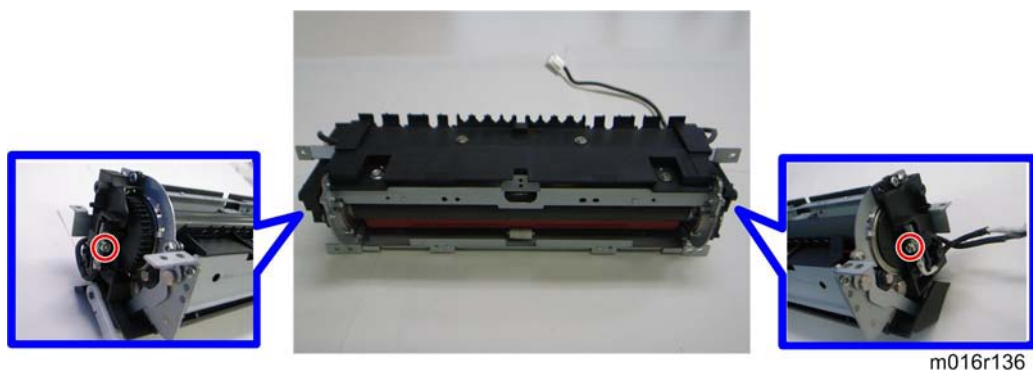

3. Ground-wires (☛ x 1 each)

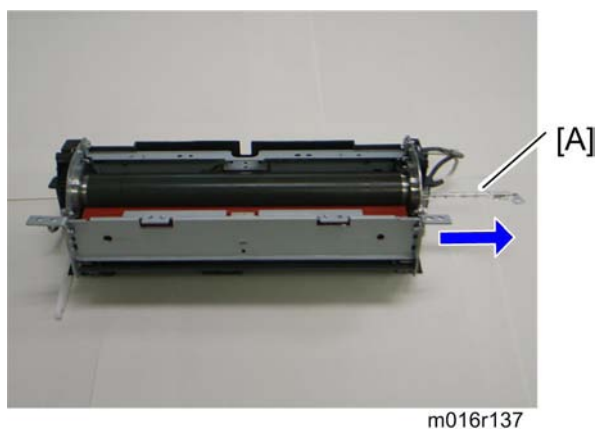

4. Fusing lamp [A]

When reinstall the fusing lamp

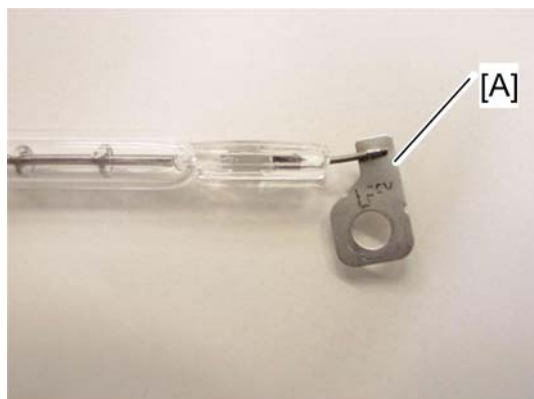

m016r138

The flat terminal [A] must be placed on the right side of the fusing unit (fusing cable side).

4

Hot Roller

1. Fusing lamp (🔌 p.68)

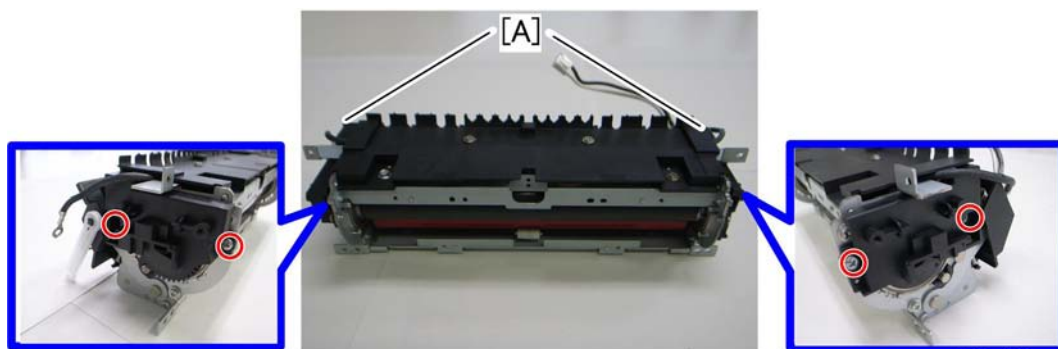

m016r139

2. Brackets [A] (🔧 x 2)

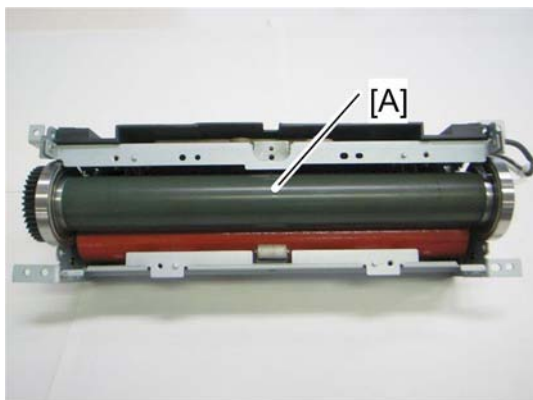

m016r140

4

3. Hot roller [A] (C-ring x 2, gear x 1, bushing x 2)

Pressure Roller

1. Hot roller (☛ p.69)

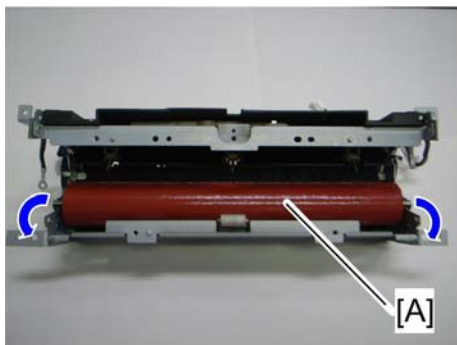



m016r148

2. Pressure roller [A] (Bearing x 2)

Hot Roller Stripper Pawls

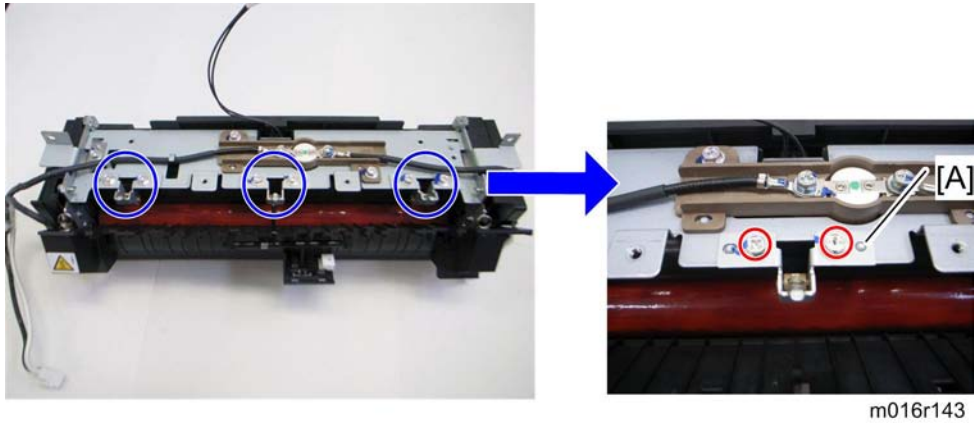
1. Fusing unit (☛ p.64)
2. Fusing unit upper cover (☛ p.66)



3. Metal holders [A] (1 holder for each pawl:  x 2 each)

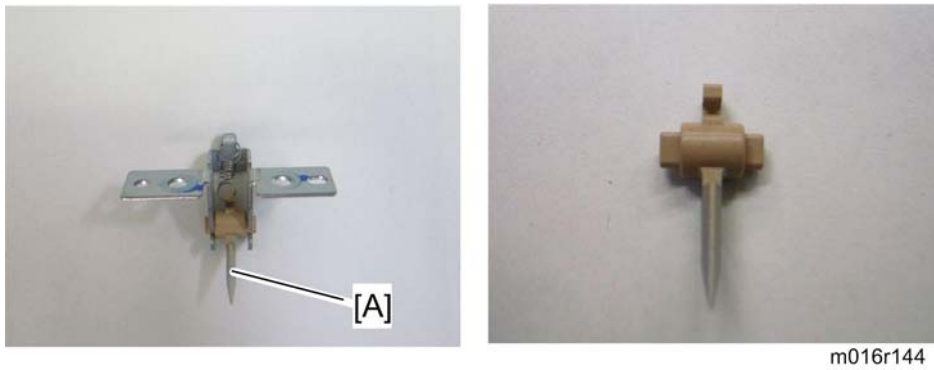

4. Hot roller stripper pawls [A] (1 spring for each pawl)

Motors

Main Motor

1. Front cover (🔩 p.23)
2. Left cover (🔩 p.24)

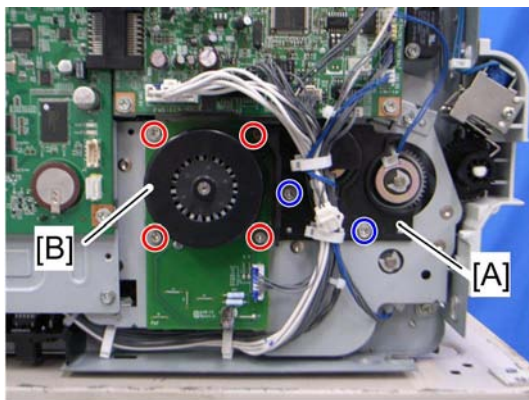

m016r108

3. Harness guide [A] (🔩 x 2)
4. Main motor [B] (🔩 x 4, 📦 x 1)

Duplex Motor (For M017)

1. Front cover (🔩 p.23)
2. Left cover (🔩 p.24)
3. Rear cover (🔩 p.27)
4. Right cover (🔩 p.28)
5. Top cover (🔩 p.29)

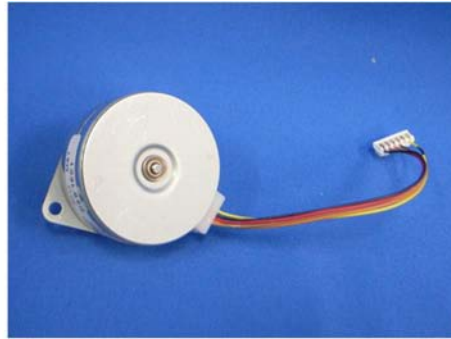
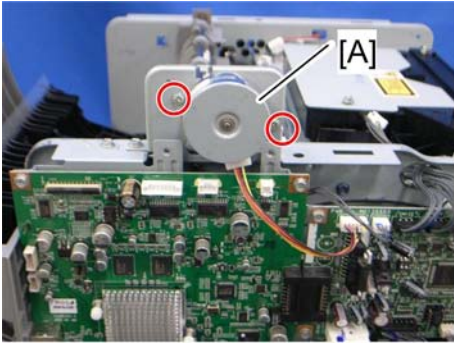

m016r123

6. Duplex motor [A] (🔧 x 2, 📏 x 1)

Electrical Components

Layout of PC Boards

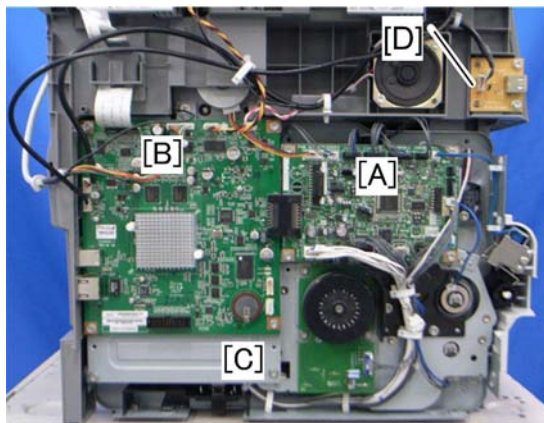

m016r114

[A]	ECB (Engine Controller Board)
[B]	Controller Board
[C]	FCU (Fax Control Unit) - behind the main controller board
[D]	USB Board

ECB (Engine Controller Board)

1. Front cover (🔧 p.23)
2. Left cover (🔧 p.24)

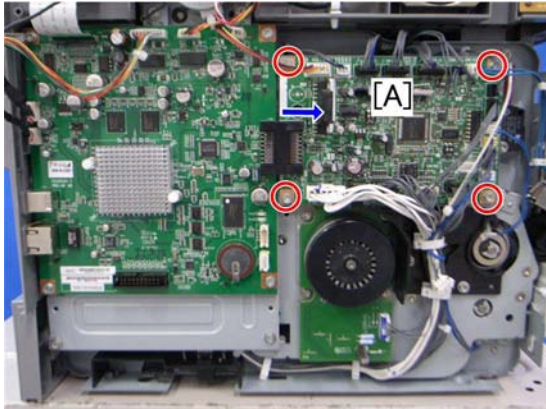

m016r115

3. ECB [A] (⚙️ x 4, all ⚙️s)

↓ Note

- Do not connect any connectors to CN181 when reinstalling the ECB [A]. CN181 is only used for factory.
- Do not change the dip switch. The dip switch is only for factory use.

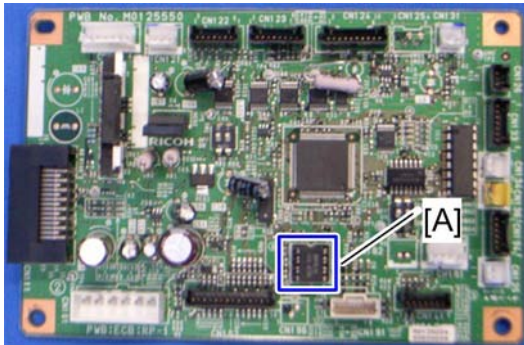

m016r118

4. EEPROM (Electrically Erasable Programmable Read Only Memory) [A]

When installing the new ECB (Engine Controller Board)

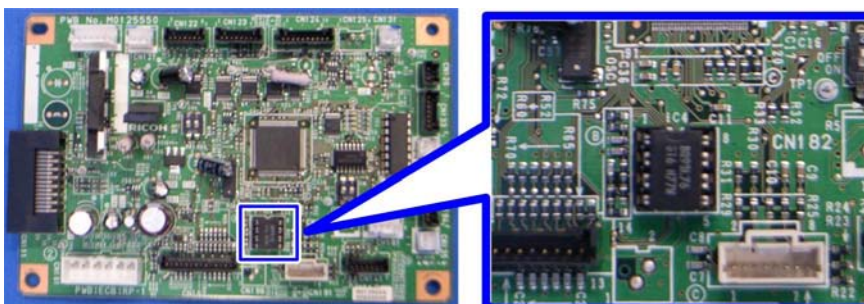

m016r117

1. Remove the EEPROM from the old ECB.
2. Install it on the new ECB after replacing the ECB.
3. Replace the EEPROM if the EEPROM on the old ECB is defective.

CAUTION

- Keep the EEPROM away from any objects that can cause static electricity. Static electricity can damage EEPROM data.
- Make sure that the EEPROM is correctly installed on the ECB.

EEPROM

4

- Replacement procedures for the new EEPROM are included in the "ECB (Engine Controller Board)" replacement procedure. Refer to "ECB (Engine Controller Board)" for details.
- Do the following settings after installing a "new" EEPROM.
 - Input the PnP Name, Destination in Maintenance mode.
 - Adjust registration in Maintenance mode.
 - Input serial number on the serial number input display after installing the new EEPROM

Note

- Ask your supervisor about how to access the serial number input display.

Controller Board

CAUTION

- Risk of explosion if battery is replaced by an incorrect type. Dispose of used batteries according to the instructions.
1. ECB ( p.74)

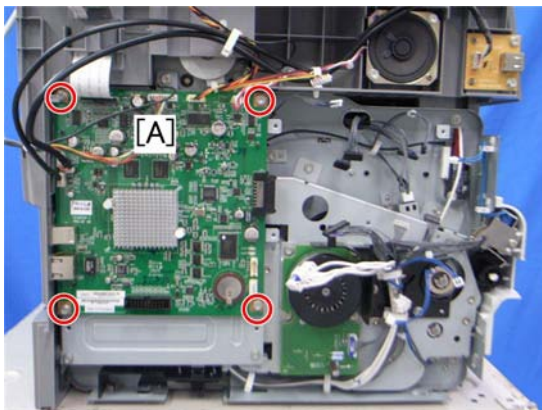

m016r116

2. Controller board [A] (🔩 x 4, flat cable x 1, all 📡s)

FCU

1. ECB (🔩 p.74)
2. Controller board (🔩 p.76)

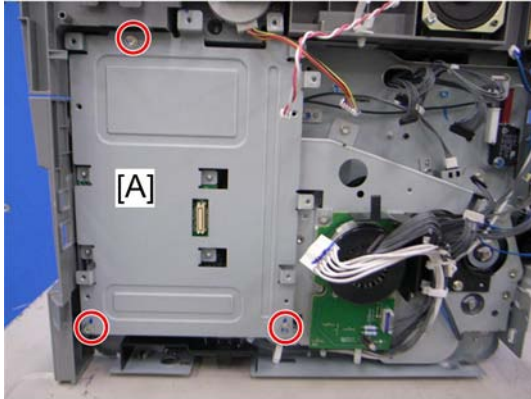

m016r683

3. Controller board bracket [A] (🔩 x 3)



m016r120

4. FCU [A] (🔩 x 4)

USB Host Board

1. Left cover (🔩 p.24)



2. USB host board [A] (🔩 x 2, 📏 x 1)

PSU

1. Pull out the standard paper tray.
2. Front cover (🔩 p.23)
3. Left cover (🔩 p.24)
4. Rear cover (🔩 p.27)
5. Right cover (🔩 p.28)
6. Scanner unit (🔩 p.40)
7. Top cover (🔩 p.29)
8. ECB (🔩 p.74)
9. Controller board bracket (🔩 p.77)
10. Drive unit (🔩 p.55 "Paper Feed Clutch")

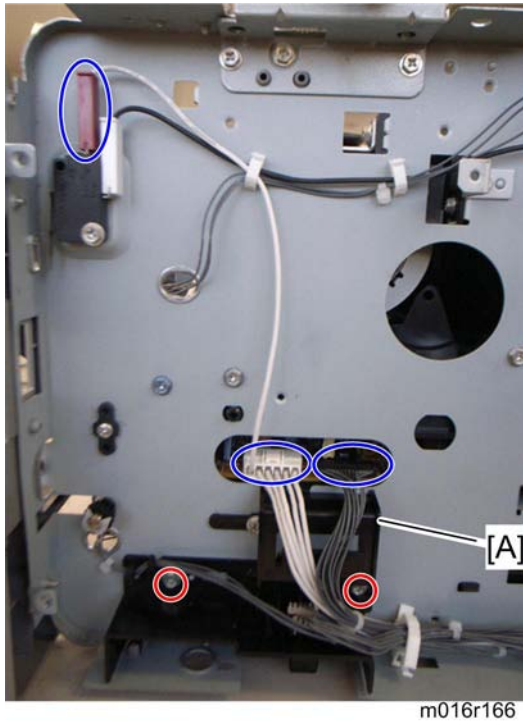

11. Disconnect three connectors in left frame (🔌 x 1)
12. Bracket [A] (🔧 x 2)

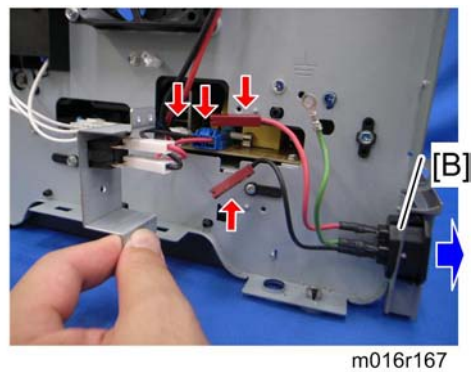
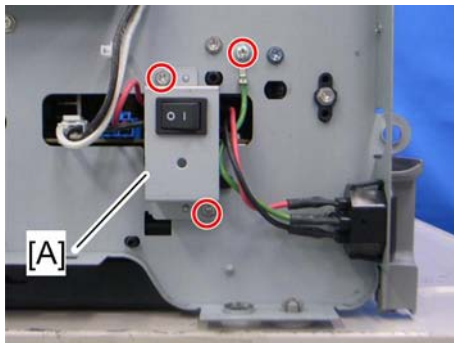

13. Main power switch bracket [A] in right frame (🔧 x 2)
14. Remove the main power cord [B] as shown above (🔌 x 2).
15. Remove the ground wire and two connectors.

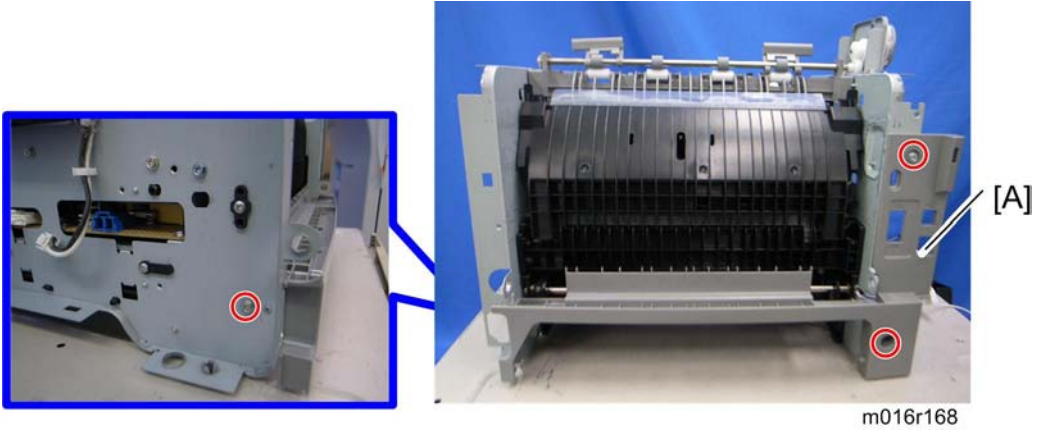

4 16. Rear low cover [A] (🔩 x 3)



- 17. Entrance guide [A]
- 18. Fusing Unit (🔗 p.64)

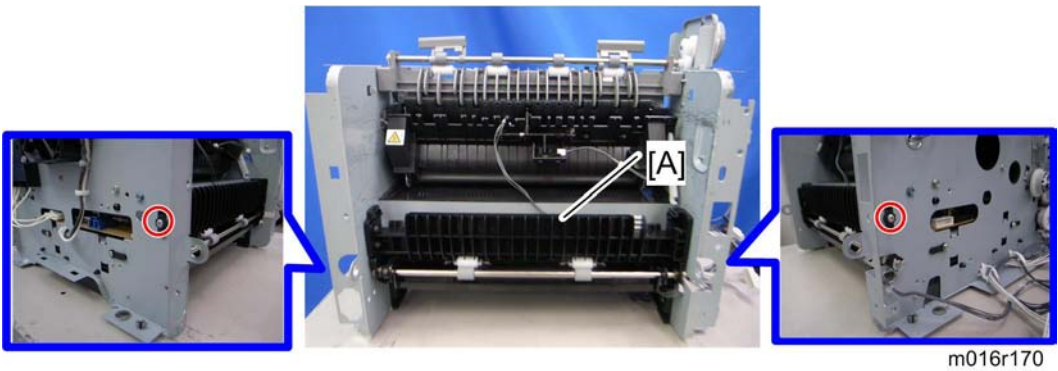

19. For M017 only: Duplex transport guide [A] (🔩 x 2)

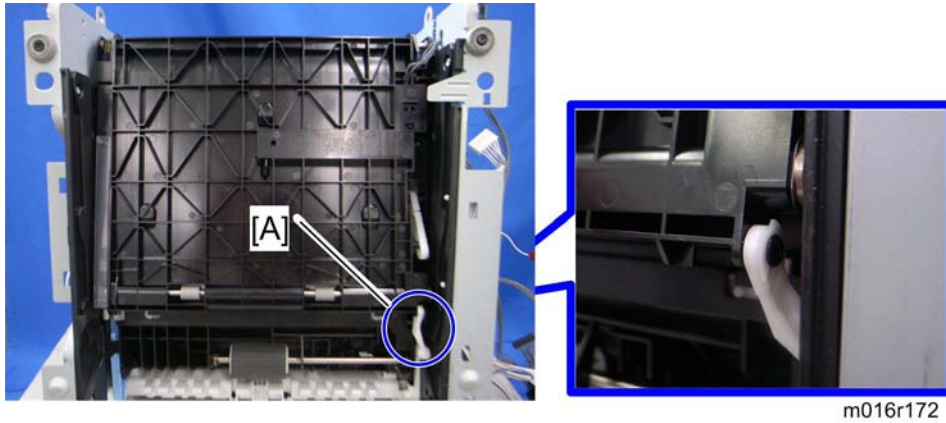

20. For M017 only: Set the machine with the front side facing down, resting on the table.

21. For M017 only: Release the link [A] (🔧 x 1)

4

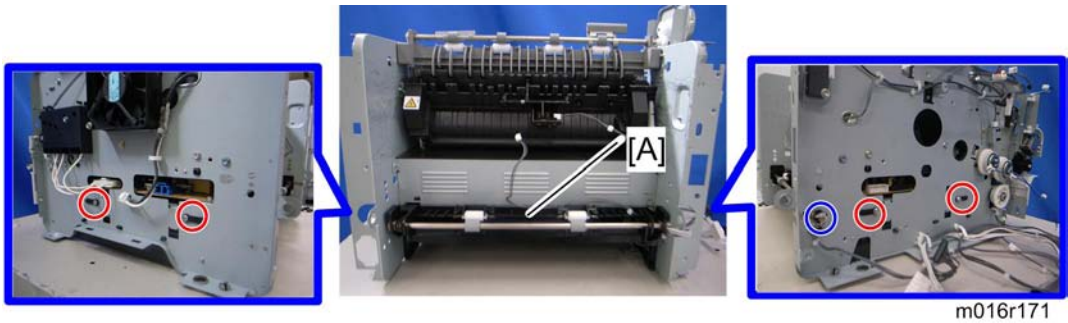

22. For M017 only: Duplex cover [A] (🔧 x 4, ⚙️ x 1, gear x 1)

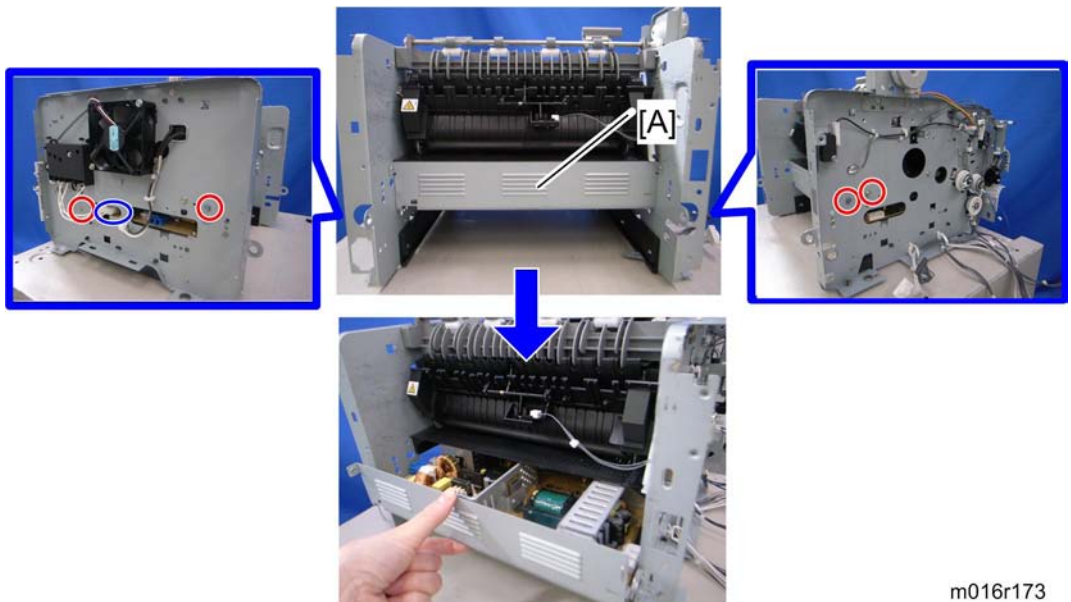

23. PSU [A] (🔧 x 4, 📡 x 1)

Charge Terminal Case

1. Right cover (🔧 p.28)

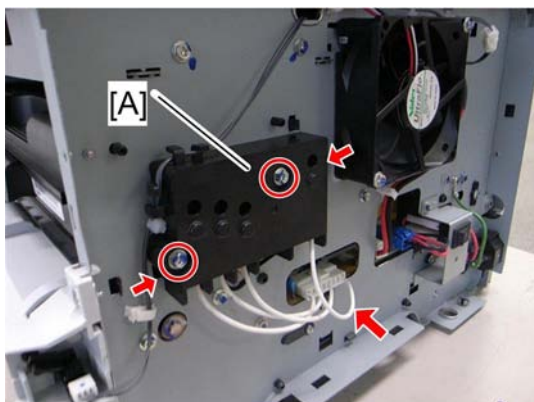

m016r174

2. Charge terminal case [A] with the harness (🔧 x 2, 📡 x 1, hooks)

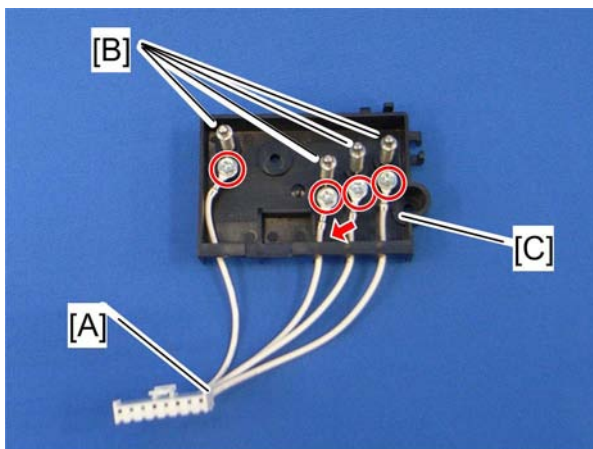

m016r175

3. Remove the harness [A] (🔧 x 4).
4. Remove the four springs and terminal pins [B].
5. Charge terminal case [C]

Others

Cooling Fan

1. Right cover (☛ p.28)

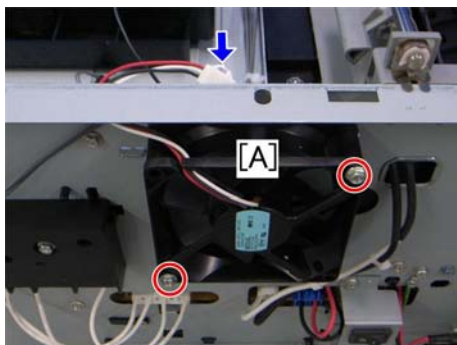

m016r124

2. Cooling fan [A] (🔧 x 2, 📏 x 1)

⚠ CAUTION

- Install the Cooling fan [A] with its decal facing the outside of the machine.

Speaker

1. Left cover (☛ p.24)

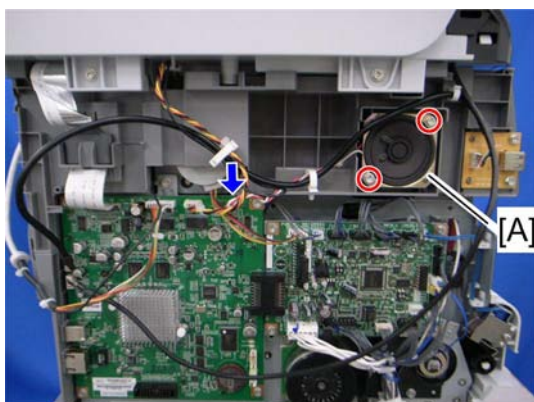

m016r125

2. Speaker [A] (🔧 x 2, 📏 x 1, 📏 x 1)

Quenching Lamp

1. Top Cover (☛ p.29)

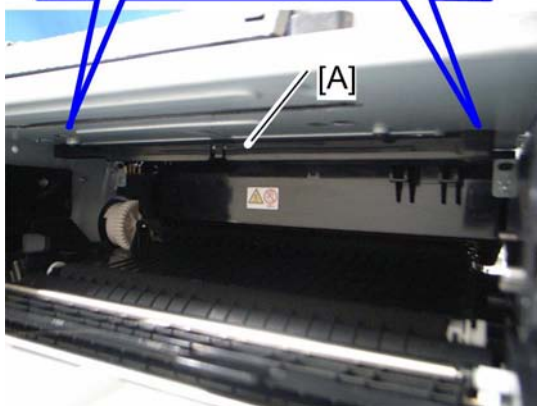
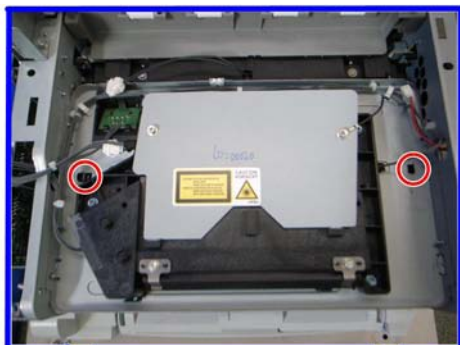

m016r161

2. Release two hooks of the quenching lamp with the case [A], and remove it.



m016r162

3. Remove the quenching lamp [A] from the case (hook x 3).

Image Adjustment

Registration Adjustment

User Adjustment

The paper registration can also be adjusted with the user mode ("Engine Maintenance Registration"). For details, see the "User Guide".

Service Adjustment

1. Print the test page (☛ p.124).
 - Print out the test pattern before changing the paper registration setting.
2. Enter the "Maintenance Mode".
3. Select "Engine Maintenance", and then press "OK" key.
4. Select the "Registration", and then press "OK" key.

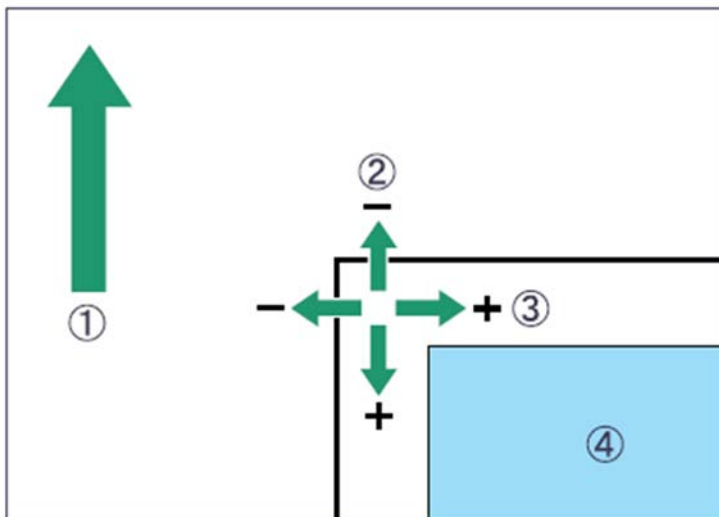

m016t500

- (1): Feed Direction
- (2): Vertical Adjustment
- (3): Horizontal Adjustment
- (4): Print Area

5. Press the "Up" or "Down" keys to set the registration value (mm).

- Increase the value to shift the print area in the plus direction.
 - Decrease to shift in the minus direction.
6. Adjust the margins of the test page so that they are equal in size.

5. System Maintenance Reference

Service Program Mode

Overview

This model has several service menus. Each service menu has several adjustment items. This section explains how to enter each service menu and what you can do in each service menu.

Maintenance Mode Menu

Selecting an Item

To select an item, press the "Up" or "Down" key.

Going into the Next Level/ Returning to the Previous Level

- To go into the next level of an item, select an item then press the "OK" key.
- To return to the previous level of an item, press the "Return" key.

Exiting the Maintenance Mode Menu

To exit the maintenance mode menu, press the "Clear/Stop" or "Return" key until the "Ready" display appears.

Menu List

Display Info		
Model Name		Displays the Model Name, Depends on Engine Firmware Settings
FW Ver.	CTL FW Ver.	Displays the Firmware Version
	FAX FW Ver.	Displays the FAX Firmware Version.
	Engine FW Version	Displays the Engine Firmware Version
	PDL FW Ver.	Displays the PDL Firmware Version.

Display Info		
Counter	Printer Counter	Displays the following counters of the printer engine. Total Page
	Scanner Counter	Displays the sum total of scanner counters for each mode. Total Page/ Black Page/ Color Page / ADF Used
	Jam Counter	Displays the number of paper jams at each location. Total/ ADF/ Outer/ Inner/ Tray1 Misfeed/ Tray2 Misfeed/ Duplex Misfeed/ Bypass Tray Misfeed

Print Reports	
G3 Protocol dump list	G3 protocol dump of the latest communication is printed. Off (Default)/ Error/ On

Engine Maintenance	
P _N P Name	NA Model: RICOH/ 'nul' EU Model: RICOH/ NRG/ LANIER ASIA Model: RICOH/ LANIER China Model: RICOH
Destination	Sets the destination and updates the engine setting. JPN/ NA/ EU (Default)/ ASIA/ China/ TAIWAN/ COREA

Engine Maintenance		
Registration	Horiz. Tray1	Adjusts the horizontal registration for tray 1. If the machine settings are reset to the factory defaults, this value does not change. [-40 to 40 / 0 (Default) / 0.1 mm/step]
	Vert. Tray1 Plain Paper	Adjusts the vertical registration of plain paper for tray1. If the machine settings are reset to the factory defaults, this value does not change. [-40 to 40 / 0 (Default) / 0.1 mm/step]
	Vert. Tray1 Thick Paper	Adjusts the vertical registration of thick paper for tray 1. If the machine settings are reset to the factory defaults, this value does not change. [-40 to 40 / 0 (Default) / 0.1 mm/step]
Registration	Vert. Tray1 Thin Paper	Adjusts the vertical registration of thin paper for tray 1. If the machine settings are reset to the factory defaults, this value does not change. [-40 to 40 / 0 (Default) / 0.1 mm/step]
	Horiz. Tray2	Adjusts the horizontal registration for tray 1. If the machine settings are reset to the factory defaults, this value does not change. [-40 to 40 / 0 (Default) / 0.1 mm/step]
	Vert. Tray2 Plain Paper	Adjusts the vertical registration of plain paper for tray 2. If the machine settings are reset to the factory defaults, this value does not change. [-40 to 40 / 0 (Default) / 0.1 mm/step]
	Vert. Tray2 Thin Paper	Adjusts the vertical registration of thin paper for tray 2. If the machine settings are reset to the factory defaults, this value does not change. [-40 to 40 / 0 (Default) / 0.1 mm/step]
	Vert. Tray2 Thick Paper	Adjusts the vertical registration of thick paper for tray 2. If the machine settings are reset to the factory defaults, this value does not change. [-40 to 40 / 0 (Default) / 0.1 mm/step]

Engine Maintenance		
Registration	Horiz. Bypass	Adjusts the horizontal registration for the bypass tray. If the machine settings are reset to the factory defaults, this value does not change. [-40 to 40 / 0 (Default) / 0.1 mm/step]
	Vert. Bypass Plain Paper	Adjusts the vertical registration of plain paper for the bypass tray. If the machine settings are reset to the factory defaults, this value does not change. [-40 to 40 / 0 (Default) / 0.1 mm/step]
	Vert. Bypass Thick Paper	Adjusts the vertical registration of thick paper for the bypass tray. If the machine settings are reset to the factory defaults, this value does not change. [-40 to 40 / 0 (Default) / 0.1 mm/step]
	Vert. Bypass Thin Paper	Adjusts the vertical registration of thin paper for the bypass tray. If the machine settings are reset to the factory defaults, this value does not change. [-40 to 40 / 0 (Default) / 0.1 mm/step]
	Horiz. Dup. Back	Adjusts the horizontal registration the back side in duplex mode. If the machine settings are reset to the factory defaults, this value does not change. [-40 to 40 / 0 (Default) / 0.1 mm/step]
Registration	Vert. Dup. Plain Paper	Adjusts the vertical registration of plain paper for the back side in duplex mode. If the machine settings are reset to the factory defaults, this value does not change. [-40 to 40 / 0 (Default) / 0.1 mm/step]
	Vert. Dup. Thin Paper	Adjusts the vertical registration of thin paper for the back side in duplex mode. If the machine settings are reset to the factory defaults, this value does not change. [-40 to 40 / 0 (Default) / 0.1 mm/step]
	Vert. Dup. Thick Paper	Adjusts the vertical registration of thick paper for the back side in duplex mode. If the machine settings are reset to the factory defaults, this value does not change. [-40 to 40 / 0 (Default) / 0.1 mm/step]

Engine Maintenance		
Brand ID	00* – 7F Displays the current brand ID number. Do not change this setting (Designed for Factory Use).	
Fuser SC Reset	This button is for resetting an SC related with the fusing errors.	
Bypass Tray Priority	Turns on or off the paper priority feeding from the bypass tray. [On or Off]	
Reset Transfer Roller Life	Clears the EM counter of the transfer roller.	
Reset Paper Feed Roller Life	Clears the EM counter of the paper feed roller.	
Reset Fusing Unit Life	Clears the EM counter of the fusing unit.	
Motor Rotation Time	Displays the main motor rotation time.	
Print Cartridge Info	Kind ID	Displays the toner cartridge (AIO) information (Kind ID).
	Toner End History	Displays the toner cartridge (AIO) information (Toner End History).
	Refill Flag Status	Displays the toner cartridge (AIO) information (Refill flag status).
	Unit Print Counter	Displays the toner cartridge (AIO) information (Unit Print Counter).
OPC Life Info	OPC Rotation Time	Displays the OPC life information (OPC rotation time).
	Pre-OPC Rotation Time	Displays the OPC life information (Pre-OPC rotation time)
	OPC Alert Status	Displays the OPC life information (Alert status)
	OPC Pre-Alert Status	Displays the OPC life information (Pre-Alert status)

Engine Maintenance		
EM Counter Info	Remain of Transfer Roller	Displays the total counter (Remain of Transfer Roller).
	Transfer Roller - Time	Displays the EM counter (Transfer Roller: Time).
	Transfer Roller - Pages	Displays the EM counter (Transfer Roller: pages).
	Remain of Paper Feed Roller	Displays the total counter (Remain of Paper Feed Roller).
	Paper Feed Roller - Pages	Displays the EM counter (Paper Feed Roller: pages).
	Remain of Fusing Unit	Displays the total counter (Remain of Fusing Unit).
	Fusing Unit - Time	Displays the EM counter (Fusing Unit: time).
	Fusing Unit - Pages	Displays the EM counter (Fusing Unit: pages).
Total Counter Info	Engine Counter	Displays the total counter (Engine).
Clear Engine Memory	Resets the engine settings stored in the EEPROM to factory default.	
SC559 Detection	[On or Off (Default)]	
EM Life Display	Sets the display of alert when each EM parts yield of this machine is reached. [On or Off (Default)]	

Engine Maintenance		
Output check	Main Motor	Output check (Main Motor)
	Middle clutch	Output check (Relay Clutch)
	Tray1 clutch	Output check (Paper Feed Clutch)
	Bypass solenoid	Output check (Bypass solenoid)
	Regist clutch	Output check (Registration Clutch)
	Reserve clutch	Output check (Reserve clutch)
	Fan High Speed	Output check (Fan High Speed)
	Fan Low Speed	Output check (Fan Low Speed)
	Erase Lamp	Output check (Quenching Lamp)
	Polygon Motor	Output check (Polygon Motor)
	Tray2 Motor	Output check (Tray2 Motor)
	Dup Motor Normal	Output check (Duplex Motor Normal)
	Dup Motor Reserve	Output check (Duplex Motor Reverse)

Engine Maintenance		
Paper Buckle Amount	Vert. Tray1 Plain Paper	Adjusts the amount of paper buckle at the registration roller for each tray and paper type. [-8 to 8 / 0 (Default) / 1 mm/step]
	Vert. Tray1 Thick Paper	
	Vert. Tray1 Thin Paper	Adjusts the amount of paper buckle at the registration roller for each tray and paper type. [-8 to 8 / -2 (Default) / 1 mm/step]
	Vert. Bypass Plain Paper	Adjusts the amount of paper buckle at the registration roller for each tray and paper type. [-8 to 8 / 0 (Default) / 1 mm/step]
	Vert. Bypass Thick Paper	
	Vert. Bypass Thin Paper	
	Vert. Tray2 Plain Paper	Adjusts the amount of paper buckle at the registration roller for each tray and paper type. [-8 to 8 / 0 (Default) / 1 mm/step]
	Vert. Tray2 Thin Paper	
	Vert. Tray2 Thick Paper	
	Vert. Dup. Plain Paper	Adjusts the amount of paper buckle at the registration roller for each tray and paper type. [-8 to 8 / 0 (Default) / 1 mm/step]
	Vert. Dup. Thin Paper	
	Vert Dup. Thick Paper	
	Fusing Unit Temperature	Plain Paper
Thick1 Paper		Adjusts the fusing temperature for thick 1 paper. [160 to 200 / 185 (Default) / 5°C/step]
Thick2 Paper		Adjusts the fusing temperature for thick 2 paper. [160 to 200 / 185 (Default) / 5°C/step]
Standby		Adjusts the fusing temperature in the standby mode. [120 to 175 / 155 (Default) / 1°C/step]
Low Power		Adjusts the fusing temperature in the low power mode. [80 to 135 / 120 (Default) / 5°C/step]

Engine Maintenance		
Fusing Unit Temperature	Thin Paper	Adjusts the fusing temperature for thin paper. [140 to 165 / 150 (Default) / 5°C/step]
	Envelope	Adjusts the fusing temperature for envelope. [170 to 200 / 200 (Default) / 5°C/step]
	Postcard	Adjusts the fusing temperature for postcard. [160 to 200 / 185 (Default) / 5°C/step]
	Recycled	Adjusts the fusing temperature for recycled paper. [150 to 180 / 160 (Default) / 5°C/step]
Charge Bias	Adjusts the charge bias. [1100 to 1300 / 1200 / 20 /step]	
Developer Bias	Adjusts the developer bias. [270 to 330 / 300 / 15 /step]	
Trans. Roller Bias	Adjusts the transfer roller bias. [-6 to 6 / 0 / 1 /step]	
Subscan Magnification	Adjusts the sub scan magnification. [-8 to 8 / 0 / 1 /step]	
Toner Near End To Toner End	Sheets	Adjusts the printable sheets between "toner near end" to "toner end". [0 to 255 / 200 / 1 sheet/step]
	Dot Count	Adjusts the printable dot count between "toner near end" to "toner end". [0 to 255 / 100 / 1 dot/step]

Engine Maintenance		
Waste toner disposal	Independent-Supply Toner	<p>Sets the machine operation at "waste toner full" of the refilled AIO.</p> <p>[On or Off (Default)]</p> <p>Note</p> <ul style="list-style-type: none"> With main motor rotation count feature, machine can be set to stop printing after print total exceeds a certain set value. If print count exceeds this value, then "Replace Print Cartridge" remains in display. Then a new AIO cartridge must be installed. This feature is a safety measure to prevent the used toner tank from becoming full (there is no toner overflow detection mechanism).
Test Pattern	Prints the test pattern.	
Curl Control mode	<p>Corrects the face curl of paper.</p> <p>0: OFF (28ppm)</p> <p>1: Sets the engine speed at 14ppm after printing 1 minute.</p> <p>2: Sets the engine speed at 14ppm.</p> <p>3 to 255: not available</p> <p>[0 to 255 / 0 / 1 /step]</p>	
Adjust of Charge Bias	<p>Charge bias correction for dirty background</p> <p>0: OFF (Default)</p> <p>1: ON</p> <p>2 to 255: not available</p> <p>[0 to 255 / 0 / 1 /step]</p>	

Scan Maintenance	
Mono Compression Setting	<p>Sets the monochrome compression type for scanning.</p> <p>MH (Default)/ MR/ MMR</p>

Scan Maintenance		
Regist Adjust	ADF Main Reg.	Adjusts the ADF Scan main-scan registration. [-2.0 to 2.0 / 0 (Default)/ 0.1 mm/step]
	ADF Sub Reg.	Adjusts the ADF Scan sub-scan registration. [-2.0 to 2.0 / 0 (Default)/ 0.1 mm/step]
	Flatbed Main Reg.	Adjusts the Flatbed Scan main-scan registration. [-2.0 to 2.0 / 0 (Default)/ 0.1 mm/step]
	Flatbed Sub Reg.	Adjusts the Flatbed Scan sub-scan registration. [-2.0 to 2.0 / 0 (Default)/ 0.1 mm/step]
Size Adjust	ADF Main Reg.	Adjusts the ADF Scan main-scan magnification. [-0.9 to 0.9 / 0 (Default)/ 0.1 %/step]
	ADF Sub Reg.	Adjusts the ADF Scan sub-scan magnification. [-0.9 to 0.9 / 0 (Default)/ 0.1 %/step]
	Flatbed Main Reg.	Adjusts the Flatbed Scan main-scan magnification. [-0.9 to 0.9 / 0 (Default)/ 0.1 %/step]
	Flatbed Sub Reg.	Adjusts the Flatbed Scan sub-scan magnification. [-0.9 to 0.9 / 0 (Default)/ 0.1 %/step]

Fax Maintenance		
Modem Settings	RX Level	Sets the reception level. [-43 dBm (Default)/ -33 dBm/ -26 dBm / -16 dBm]
	TX Level	Sets the transmission level. [0 dBm/ -1 dBm/ -2 dBm/ -3 dBm/ -4 dBm / -5 dBm/ -6 dBm/ -7 dBm/ -8 dBm/ -9 dBm / -10 dBm/ -11 dBm/ -12 dBm/ -13 dBm / -14 dBm/ -15 dBm]
	Cable Equalizer	These selectors are used to improve the pass-band characteristics of analogue signals on the telephone line. [0Km (Default)/ 1.8Km/ 3.6Km/ 7.2Km]
Protocol Definition	Training Retries	This sets the number of training retries to be repeated before automatic fallback. [1 Time/ 2 Times (Default)/ 3 Times/ 4 Times]
	Encoding	Sets the compression method for Tx/Rx. [MMR+MR+MH (Default)/ MR+MH/ MH]
Protocol Definition Timer	T0 Timer	Timeout for response from the called station in automatic sending mode [35 Sec/ 45 Sec/ 55 Sec (Default)/ 60 Sec/ 90 Sec/ 140 Sec]
	T1 Timer	Set the time length for the T1 timer. [40 Sec (Default)/ 50 Sec]
	T4 Timer	Set the time length for the T4 timer. [3 Sec (Default)/ 4.5 Sec]

Fax Maintenance		
RX Settings	Silence Detection Time	<p>Silence (No tone) detection time (Rx mode : FAX/ TAD Only)</p> <p>After the line is connected via the external telephone, the machine can detect silence (no tone) for the time length specified by this setting.</p> <p>[30 sec (Default)]</p>
	CNG Tone Detection Time	<p>CNG tone detection time (RX mode : FAX / TEL, FAX / TAD Only)</p> <p>After the line is connected via the external telephone, the machine can detect a CNG signal for the time length specified by this setting.</p> <p>[5 Sec (Default)/ 10 Sec]</p>
	CNG Cycles	<p>Number of CNG cycles to be detected</p> <p>This setting is only effective for FAX/TAD mode.</p> <p>[1.5 Cycle (Default)/ 2.0 Cycle]</p>
RX Settings	Tone Sound Monitoring	<p>Determines the period when tones from the line are monitored.</p> <p>[No Monitoring/ Up To Phase B (Default)/ All TX Phases]</p>
	Stop/Clear key	<p>Pressing the Stop/Clear key can stop the current receiving operation. Received data is lost.</p> <p>[Not Functional (Default)/ Functional]</p>
	Off-Hook Level	<p>Sets the off-hook detection threshold.</p> <p>[10V (Default)/ 15V/ 20V/ 25V 35V]</p> <p>"Telephone" was indicated by malfunction when receiving the fax message with some PABX. Some PABX may output more than 25V to the FAX input line. Selecting [35V] for [Off-hook level] by the fax maintenance mode.</p>

Fax Maintenance		
TX Settings	Redial Interval	Sets the redial interval when Tx fails. [5 Min/ 6 Min]
	Redialings	Sets the number of redials when Tx fails. [2 times/ 3 Times/ 4 Times/ 5 Times]
Overseas Comm Mode Settings	Overseas Comm Mode	This sets the machine to ignore a DIS signal sent from the called station once in a sending operation. [Off (Default)/ Ignore DIS Once]
	Minimum Time Length	If this setting is set to "On", the machine detects the CNG signal after the line is connected. If it is set to "Off", the machine detects the CNG signal as long as the line is connected. [100 Ms/ 200 Ms/ 300 Ms/ 400 Ms (Default)]
Dial Pulse Setting	Dial Pulse Type	This sets the number of pulses that are generated during dialing. <ul style="list-style-type: none"> • N: Dialing '0' generates 10 pulses --- Dialing '9' generates 9 pulses. • N+1: Dialing '0' generates 1 pulses --- Dialing '9' generates 10 pulses. • 10-N: Dialing '0' generates 10 pulses --- Dialing '9' generates 1 pulse.

Fax Maintenance		
Tone Signal Settings	Tone Signal Transmission Time Length	Sets the tone signal transmission time length [100 ms (Default)]
	Minimum Pause In Tone Dialing	Sets the minimum pause during tone dialing [100 ms (Default)/ 150 ms/ 200 ms]
	Attenuator For Pseudo Ring Backtone To the Line	Sets the attenuator for pseudo ringback tone to the line [0 to 15 / 10 (Default)/ 1 dB/step]
	DTMF Level	Sets the transmission level of DTMF tones. [-12 dBu / -11 dBu/ -10 dBu/ -8 dBu/ -6 dBu]
	DTMF Delta	Sets the level difference between high band frequency signals and low band frequency signals when sending DTMF tones. [2 dBu/ 3 dBu]
1 Dial Tone Detection	Wait Time	The machine starts dialing after the specified interval without detection of a dial tone when Dial tone detection is set to "No detection". [3.5 Sec (Default)/ 7.0 Sec/ 10.5 Sec / 14.0 Sec]
	Timeout Length	This setting sets the time-out length for the 1st dial tone detection. The machine waits for a dial tone for the specified time and disconnects itself from the line when no dial tone is input. [10 Sec (Default)/ 15 Sec/ 20 Sec/ 30 Sec]

Fax Maintenance		
BT (Busy Tone) Detection	BT Setting	DFU [Off/ On] BT: Busy tone
	BT Frequency	DFU [300-550 Hz/ 300-650 Hz/ 325-525 Hz/ 340-550 Hz/ 350-500 Hz/ 350-550 Hz/ 375-475 Hz/ 380-520 Hz]
	BT Level	DFU [-35 dB/ -36 dB/ -37 dB/ -38 dB/ -39 dB]
	BT Cadence	DFU [0.10/ 0.15/ 0.20/ 0.25/ 0.30/ 0.35/ 0.40/ 0.45/ 0.50/ 0.75]
Comm Settings	RTN Rate	The machine checks the actual data reconstruction errors and then transmits an RTN depending on the decoding error rate that is set by this setting (Number of lines containing an error per page / Total number of lines per page). [10%/ 15%]
	V34 Modem	DFU [Permitted (Default)/ Prohibited]
	V17 Modem	DFU [Permitted (Default)/ Prohibited]

Fax Maintenance		
V34 Settings	Equalizer	These selectors set the equalizer's training level to be applied if training fails due to poor line connection. [Automatic (Default)/ 4 Points/ 16 Points]
	Redialing	Resend when a communication error occurs. [Disabled (Default)/ Not Disabled]
	First TX Speed	Sets the first transmission speed choice, before fallback. [2400 Bps/ 4800 Bps/ 7200 Bps/ 9600 Bps / 12000 Bps/ 14400 Bps/ 16800 Bps/ 19200 Bps/ 21600 Bps/ 24000 Bps/ 26400 Bps/ 28800 Bps/ 31200 Bps/ 33600 Bps (Default)]
	Symbol Rate	This setting limits the transmission speed range in V.34 mode by masking the desired symbol rate(s). [Not Used (Default)/ 3429 Sym/Sec / 3200 Sym/Sec/ 3000 Sym/Sec / 2800 Sym/Sec/ 2400 Sym/Sec]

Factory Default		
Factory Default	Not Execute	Does not execute anything. Returns to an upper level.
	Execute	Resets all the settings to factory default. Note <ul style="list-style-type: none"> Clears/ resets the contents of the controller board memory (all data programmed by the user, log data) to factory default. After executing, initial setup menu starts after power-on.

CTL Maintenance		
CTL Maintenance	PDL Mode	ON = "PDL Settings" is shown (Default) OFF = "PDL Settings" is hidden

Fax Service Test Menu

Entering the Fax Service Test Menu

Turn on the machine while pressing the "Fax" key.

Selecting an Item

To select the item, press the "Up" or "Down" key.

Going into the Next Level/ Returning to the Previous Level

- To go into the next level of an item, select an item then press the "OK" key.
- To return to the previous level of an item, press the "Return" key.

5

Exiting the Maintenance Mode Menu

To exit the maintenance mode menu, press the "Clear/Stop" or "Return" key until the "Ready" display appears.

Menu List

Fax Test		
Off-Hook Test	On Hook	Executes the on hook test.
	Off Hook	Executes the off hook test
CED Test		Executes the CED test.
CNG Test	1100 Hz	Executes the CNG test
ANSam		Executes the ANSam test.
Ring Tone Test		Executes the ring tone test.
DTMF Test	Tone [0] to [9]	Executes the DTMF tone 0 to 9 test.
	Tone [*]	Executes the DTMF tone * test.
	Tone [#]	Executes the DTMF tone # test.
	Tone Stop	Executes the Stop DTMF tone test.

Fax Test		
Modem Test	[V34] 33600 bps	Generates the [V34] 33600 bps signal.
	[V34] 28800 bps	Generates the [V34] 28800 bps signal.
	[V17] 14400 bps	Generates the [V17] 14400 bps signal.
	[V17] 12000 bps	Generates the [V17] 12000 bps signal.
	[V17] 9600 bps	Generates the [V17] 9600 bps signal.
	[V17] 7200 bps	Generates the [V17] 7200 bps signal.
	[V29] 9600 bps	Generates the [V29] 9600 bps signal.
	[V29] 7200 bps	Generates the [V29] 7200 bps signal.
	[V27] 4800 bps	Generates the [V27] 4800 bps signal.
	[V27] 2400 bps	Generates the [V27] 2400 bps signal.
	[V21] 300 bps	Generates the [V21] 300 bps signal.
	Signal Stop	Generates the Stop signal.

Configuration and Maintenance Page

Overview

The configuration page and maintenance page have information about the machine's status. Print this sheet as shown below. Check the configuration page or maintenance page when doing machine maintenance.

To Print the Configuration Page/ Maintenance Page

1. Turn on the machine.

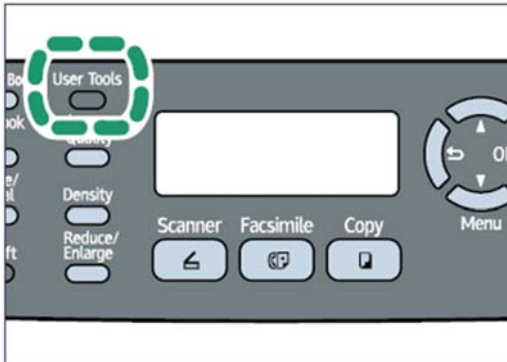

m016s112

2. Press the "User Tools" key.

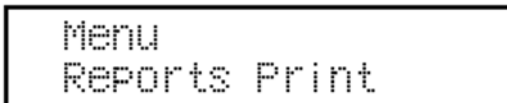

m016s113

3. Press the "Up" or "Down" key to select "Reports Print", and then press the "OK" key.

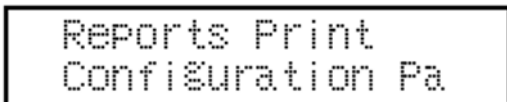

m016s114

4. Press the "Up" or "Down" key to select "Configuration Page" or "Maintenance Page", and then press the "OK" key.
5. The configuration page or maintenance page is printed.

Other Types of Reports

You can also check other reports than two reports (configuration page and maintenance page) with "Report Print" in the "Menu".

- Activity Report
Prints a fax transmission and reception report for the last 100 jobs.
- Memory List
Prints a list of unsent fax jobs remaining in the machine's memory.
- Quick Dial List
Prints a list of scan and fax Quick Dial entries.
- Speed Dial List
Prints a list of Speed Dial entries.
 - No Sort
Prints the list with the entries sorted by Speed Dial registration number.
 - Sort By Name
Prints the list with the entries sorted by name.
- Scan Directory List
Prints a list of scan destinations.
- Scan Transmission Log
Prints a scan transmission report.

Total Counter

Total Counter:

The total counter incremented by the "**engine controller board**" each time the board issues a print command to the engine.

The value is calculated as follows:

Total counter = Copier counter + Printer counter + FAX counter + Reports print

Application Counters:

Application counters exist for each individual primary machine function (Copier, Printer, FAX, etc.), and are incremented by the "**controller board**" each time the board issues a print request for the function in question.

Firmware Updating

★ Important

- Never turn the machine's main power off while the firmware is being updated, as this could damage the ECB or controller board.

Checking the Machine Firmware Version

To update the firmware for this machine, you need the most recent version of the firmware (firmware file downloadable from the Internet).

1. Turn the machine's main power on.
2. Press "User/Tool" Key and select "Reports Print" with the "Up" or "Down" key.
3. Press "OK" and select "Maintenance Page" with the "Up" or "Down" key.
4. Press "OK" to print the "Maintenance Page", which shows the "Firmware Version (Controller)" and "Engine FW version".

5

Updating the Controller Firmware

Using the following procedure to update the controller firmware, be sure to print the configuration page both before and after the update. Comparing pre- and post-update configuration pages allows you to check whether or not the update was successful.

Follow the procedure carefully, and note that it will vary in parts depending on which version of the firmware is currently installed.

Procedure

When updating firmware, always disconnect any other cable(s) than the one being used for the update operation.

(When updating firmware via USB cable, first disconnect any network and phone line cables, and when updating firmware via LAN cable, first disconnect any USB and phone line cables.)

1. Prepare:
 - Computer
 - USB cable or LAN (Local Area Network) cable
2. Download the firmware files to your computer.



3. Make a folder on a local drive of your computer and save the files there.

Note

- "FWUpdate ToolSP.exe": Used for Controller firmware or Engine firmware
- "FWUpdate Tool.exe": Used for Controller firmware

4. Connect a USB cable between a computer and the machine.
5. Click the "FWUpdateToolSP.exe" or "FWUpdateTool.exe" file to execute the updating program.

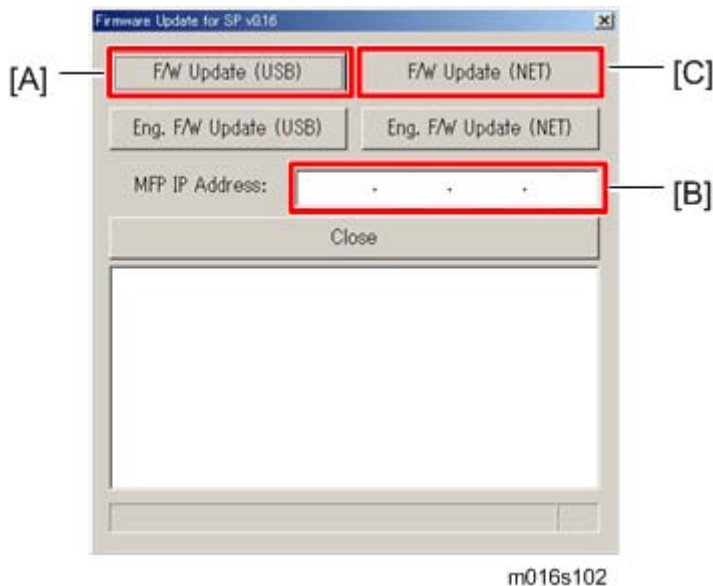

6. For a USB connection, click "F/W Update (USB)" [A]. For a network connection, enter the machine's IP address in "MFP IP Address" [B], and then click "F/W Update (NET)" [C].
7. The message "Download complete" appears.

CAUTION

- Do not turn the main power off from this point until the update procedure is completed.

8. The following message appears on the screen:
"Firmware is Updating ..."
9. Wait until the update is finished.

Note

- Do not touch the machine during updating!

10. The update is finished when "Firmware Update Done. Please Reboot" appears on the operation panel's display.
11. Turn the main power of the machine off, and then turn it back on.
12. Print a configuration page to check the machine's firmware version.

Updating the Engine Firmware

Procedure

When updating firmware, always disconnect any other cable(s) than the one being used for the update operation.

(When updating firmware via USB cable, first disconnect any network and phone line cables, and when updating firmware via LAN cable, first disconnect any USB and phone line cables.)

5

1. Prepare:
 - PC
 - USB cable or network cable
2. Download the firmware file to your computer.

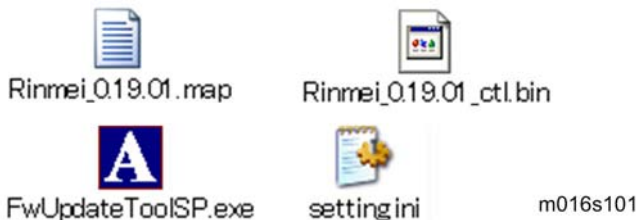

3. Make a folder on a local drive of your computer and save the files there.
4. Connect a USB cable between your computer and the machine.
5. Click the "FWUpdateToolSP.exe" file to execute the updating program.



m016s103

5

6. The above updating program should appear on the screen.

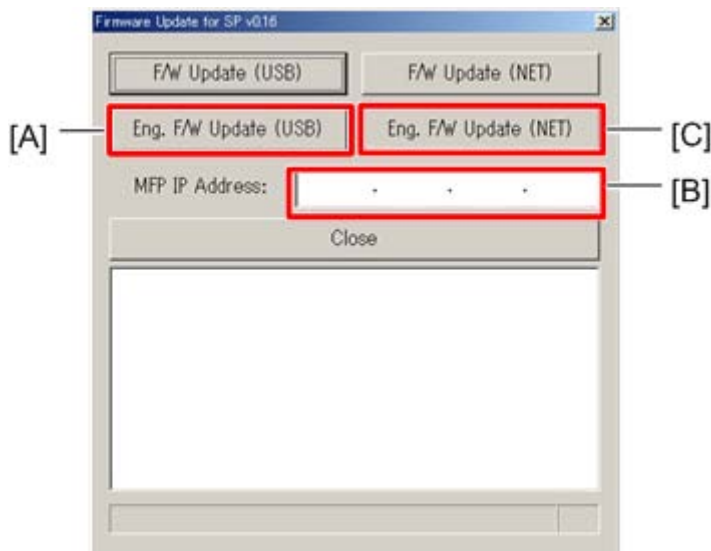

m016s106

7. For a USB connection, click "Eng. F/W Update (USB)" [A]. For a network connection, enter the machine's IP address in "MFP IP Address" [B], and then click "Eng. F/W Update (NET)" [C].
8. The update is in progress when "Firmware is Updating" appears.

Note

- You will see the progress percentage appear while the update is in progress.
- Do NOT turn the main power of the machine off during updating.

9. The update is finished when "Firmware Update Done. Please Reboot Engine." appears.
10. Turn the main power of the machine off, and then back on.

Updating the Boot Loader Firmware

This is also listed on the configuration page, but this firmware is not updated in the field.

Updating Failure

If the firmware update is not successful, the update process is suspended and an error message should display on the FW Update Tool screen. If this happens, DO NOT turn off the machine, and execute the update procedure again (unless the error message "Downloaded file is broken! Do NOT use print, scan, fax and copy function at the same time." is displayed).

5

If power is turned off accidentally during a firmware update, the firmware will not be correctly updated, and the machine may not start up normally. If the machine does not start up normally, the controller firmware and/or the engine firmware will need to be updated again.

When the machine does not start up normally, in most cases, the panel display will indicate one of the following two conditions:

- When attempting to restart the machine, the LCD panel display indicates "Initializing" indefinitely.
In this case, the controller firmware update has failed. The controller firmware must be updated again.
- When attempting to restart the machine, the LCD panel display indicates "Please Download Engine FW Again!"
In this case, the engine firmware update has failed. The engine firmware must be updated again.

FW Update Tool Messages

FW Update Tool Messages: Information

Message for USB update

Messages	Comment	Action
USB Upload : End of data	Send F/W file to MFP successfully. (Transmission Time: <30 sec)	Please reboot MFP after panel shows reboot message.

Messages	Comment	Action
USB Upload : FAIL	Can not open USB printer driver while F/W file is transmitted.	Check USB cable connection. Check the installation of USB Print Driver if it is available. Check MFP status if it is available.
	F/W file transmission can not be completed. (Transmission will be canceled if timeout.)	Check USB cable connection. Check USB Print Driver if it is available. Check MFP status if it is available.
Can't open ROM file.Please check ROM file.	F/W file does not exist.	Check the download file name in setting.ini. "ImageFile="
Can't open Eng. ROM file. Please check Eng. ROM file.	Engine F/W file does not exist.	Check the download file and fw update tool is in the same folder.
New Version: Update FW	AIO FW is transmitting	Check the download file name in setting.ini. "EngImageFile="
Eng FW version: Update Eng FW	Engine FW is transmitting	Check the download file and fw update tool is in the same folder.
Firmware is Updating...	AIO FW is updating	Not available
Eng Firmware is Updating...	Engine FW is updating	Not available
FW Update Done. * * * Please reboot the Machine. * * *	F/W update is completed.	Not available
		Please reboot the Machine.

Message for Network update

Messages	Comment	Action
Connecting...	Connect to MFP.	Please wait a moment.
Net Upload : End of data	Update F/W successfully. (Transmission Time: <30 sec)	Please reboot MFP after panel shows reboot message.

Messages	Comment	Action
Net Upload : FAIL	Can not open FTP port of MFP before F/W file is transmitted. (Transmission will be canceled if timeout.)	(1) Check network cable connection. (2) Check MFP status if it is available. (3) Check MFP and PC IP address setting. (4) Check PC firewall setting about FTP.
	F/W file transmission can not be completed. (Transmission will be canceled if timeout.)	(1) Check network cable connection. (2) Check MFP status if it is available.
Can't open ROM file. Please check ROM file.	F/W file does not exist.	Check the download file name in setting.ini. "ImageFile=" Check the download file and fw update tool is in the same folder.
Can't open Eng. ROM file. Please check Eng. ROM file.	Engine F/W file does not exist.	Check the download file name in setting.ini. "EngImageFile=" Check the download file and fw update tool is in the same folder.
New Version: Update FW	AIO FW is transmitting	Not available
Eng FW version: Update Eng FW	Engine FW is transmitting	Not available
Firmware is Updating...	AIO FW is updating	Not available
Eng Firmware is Updating...	Engine FW is updating	Not available
FW Update Done. *** Please reboot the Machine.***	F/W update is completed.	Please reboot the Machine.

FW Update Tool Messages: Error

Message for USB update

Messages	Comment	Action
Machine is not ready.	Can not get MFP status form USB status channel before F/W file is transmitted.	Check USB cable connection. Check USB Print Driver if it is available. Do not update F/W when MFP is in power-on stage.
Wrong Model.	F/W file is not matched for current machine.	Please check the version of F/W file and machine if it is suitable for MFP.
Machine is busy.	F/W update is running. Other MFP functions are running.	Please wait F/W update is completed. Please wait other MFP functions are completed.
FW Update Done. *** Please reboot the Machine.***	F/W update is completed.	Please reboot the Machine.
Machine loses communication. ***Please check FW Update Done. Then reboot the Machine.***	F/W file has transmitted. Polling F/W update progress fail.	Do not reboot engine till Engine Panel display "Firmware Update Done. Please reboot". Then reboot engine.
Downloaded file is broken! Do NOT use print, scan, fax and copy function at the same time.	F/W checks the downloaded file. And get wrong checksum. So stop to modify F/W.	Check the downloaded file is not broken. Do not use MFP functions when update firmware.

Message for Network update

Messages	Comment	Action
Machine is not ready.	Can not get MFP status form Network status channel before F/W file is transmitted.	Check PC network settings and IP address. Check MFP network settings and IP address. Do not update F/W when MFP is in power-on stage.

Messages	Comment	Action
Wrong Model.	F/W file is not matched for current machine.	Please check the version of F/W file and machine if it is suitable for MFP.
Machine is busy.	F/W update is running. Other MFP functions are running.	Please wait F/W update is completed. Please wait other MFP functions are completed.
FW Update Done. * * * Please reboot the Machine. * * *	F/W update is completed.	Please reboot the Machine.
Machine loses communication. * * * Please check FW Update Done. Then reboot the Machine. * * *	F/W file has transmitted. Polling F/W update progress fail.	Do not reboot engine till Engine Panel display "Firmware Update Done. Please reboot". Then reboot engine.
Downloaded file is broken! Do NOT use print, scan, fax and copy function at the same time.	F/W checks the downloaded file. And get wrong checksum. So stop to modify F/W.	Check the downloaded file is not broken. Do not use MFP functions when update firmware.

6. Troubleshooting

Service Call Conditions

See "Appendices" for the "Error Messages".

Summary

This machine issues an SC (Service Call) code if an error occurs with the machine. The error code can be seen on the operation panel.

Make sure that you understand the following points;

1. All SCs are logged.
2. At first, always turn the main switch off and on if an SC code is displayed.
3. First, disconnect then reconnect the connectors before replacing the PCBs (if the problem concerns electrical circuit boards).
4. First, check the mechanical load before replacing motors or sensors (if the problem concerns a locked motor).

6

Fusing related SCs

To prevent damage to the machine, the main machine cannot be operated until the fusing related SC has been reset by a service representative.

- Enter the engine maintenance mode.

Press "O.K" in "Fuser SC Reset" with engine maintenance mode, and then turn the main power switch off and on.

Engine SC

SC 2xx (Laser Optics Error)

202	Polygon motor on timeout error
	The polygon mirror motor does not reach the targeted operating speed within 10 sec. after turning.

203	Polygon motor off timeout error
	The polygon mirror motor does not leave the READY status within 20 sec. after the polygon mirror motor switched off.
204	Polygon motor lock signal error
	The signal remains HIGH for 200 ms (or 4times in 50msec polling) while the polygon mirror motor is rotating. <ul style="list-style-type: none"> • Polygon motor/driver board harness loose or disconnected • Polygon motor/driver board defective • Laser optics unit defective <ol style="list-style-type: none"> 1. Turn the main power off/on the machine. 2. Replace the interface harness of the laser optics unit. 3. Replace the laser optics unit.
220	Beam Synchronize error
	The laser synchronizing detection signal for LD is not output within 400msec after the LD unit has turned on. <ul style="list-style-type: none"> • Disconnected cable from the laser synchronizing detection unit or defective connection • Defective laser synchronizing detector • Defective LD • Defective ECB <ol style="list-style-type: none"> 1. Check the connectors. 2. Replace the laser optics unit. 3. Replace the ECB.
268	Video thermistor error
	At power on, the temperature sensor in the optics unit detected a temperature lower than -30° C for more than 4 sec. -or- It detected a temperature higher than 105°C for more than 1sec. <ul style="list-style-type: none"> • Thermistor disconnected (causes extremely low temperature reading) • Thermistor damaged and short circuited (causes extremely high temperature reading) <ol style="list-style-type: none"> 1. Turn the machine's main power off, and then on. 2. Replace the thermistor.

SC 4xx (Image Transfer and Transfer Error)

491	Bias leak
	An error signal is detected for 0.2 seconds when changing the development unit.
	<ul style="list-style-type: none"> • Defective transfer roller • Defective high voltage power pack <ol style="list-style-type: none"> 1. Turn the machine's main power off, and then on.

SC 5xx (Motor and Fusing Error)

500	Main motor error
	<p>The machine does not detect a main motor lock signal within 2sec after the main motor started to rotate.</p> <p>-or-</p> <p>The machine does not release a main motor lock signal within 2sec after the main motor switched off.</p> <p>-or-</p> <p>The machine detects a main motor lock signal every 100ms for seven times consecutively, after the main motor started to rotate stably.</p>
	<ul style="list-style-type: none"> • Overload of • Torque load overload • Defective main motor • Disconnect or defective motor harness <ol style="list-style-type: none"> 1. Turn the machine's main power off, and then on. 2. Check or replace the main motor if the torque load is normal. 3. Replace the motor harness.
530	Fusing Fan Motor Error
	The FAN lock signal – High for 10 seconds, after the fan motor started to rotate.
	<ul style="list-style-type: none"> • Disconnected or defective motor harness. <ol style="list-style-type: none"> 1. Turn the machine's main power off, and then on.

541	Fuser thermistor error
	The thermistor output is less than 0°C for 5 seconds after the fusing lamp turns ON.
	<ul style="list-style-type: none"> • Disconnected or defective thermistor • Disconnected or defective fusing lamp <ol style="list-style-type: none"> 1. Check the harness connection of the thermistor. 2. Replace the fusing unit. <p>★ Important</p> <ul style="list-style-type: none"> • Execute "Engine Maintenance Menu" to recover the machine after completing the recovery procedure. Otherwise, the machine continues to • issue this SC code and cannot be operated.
542	<p>Fuser reload error</p> <p>This SC is issued if one of following conditions occurs:</p> <p>The fusing temperature rises 8°C or less in 1.5 seconds; and this continues 5 times consecutively.</p> <p>-or-</p> <p>The fusing temperature has not reached 45°C within 9 seconds (after the fusing lamp comes ON while the machine is warming-up).</p> <p>-or-</p> <p>The fusing unit does not attain reload temperature within 35 s. (normal temperature) or 65 s (lower temperature – the thermistor output is less than 18°C) after the fusing temperature control starts.</p> <ul style="list-style-type: none"> • Defective or deformed thermistor • Incorrect power supply input at the main power socket <ol style="list-style-type: none"> 1. Defective fusing lamp

543	High temperature error (Software)
	<ul style="list-style-type: none"> The detected temperature stays at 225°C for 1 second, and this consecutively occurs 10 times.
	<ul style="list-style-type: none"> Defective ECB Defective PSU <ol style="list-style-type: none"> Replace the ECB Replace the PSU <p>★ Important</p> <ul style="list-style-type: none"> Execute "Fuser SC Reset" to recover the machine after completing the recovery procedure. Otherwise, the machine continues to issue this SC code and cannot be operated.
544	High temperature error (Hardware)
	<ul style="list-style-type: none"> During stand-by mode or a print job, the detected heating roller temperature reaches 250° C.
	<ul style="list-style-type: none"> Defective ECB Defective PSU <ol style="list-style-type: none"> Replace the ECB Replace the PSU <p>★ Important</p> <ul style="list-style-type: none"> Execute "Fuser SC Reset" to recover the machine after completing the recovery procedure. Otherwise, the machine continues to issue this SC code and cannot be operated.
545	Fusing Lamp Overheat Error
	The fusing lamps remained ON at full capacity for more than 9 s after the fusing temperature attains reload temperature.
	<ul style="list-style-type: none"> Deformed thermistor Thermistor not in the correct position Defective fusing lamp <ol style="list-style-type: none"> Replace the fusing unit. Replace the fusing lamp. <p>★ Important</p> <ul style="list-style-type: none"> Execute "Fuser SC Reset" to recover the machine after completing the recovery procedure. Otherwise, the machine continues to issue this SC code and cannot be operated.

547	Zero cross error
	<ul style="list-style-type: none"> • The zero cross signal is detected three times even though the fusing lamp relay is off when turning on the main power. • The zero cross signal is not detected for 3 seconds even though the fusing lamp relay is on after turning on the main power or closing the front door. • The detection error occurs twice or more in 11 zero cross signal detections. This error is defined when the detected zero cross signal is less than 45. • The zero cross signal is not detected three times while the main power remains ON. <ul style="list-style-type: none"> • Defective fusing relay • Defective fusing relay circuit • Shorted +24V fuse on the PSU • Unstable power supply. <ol style="list-style-type: none"> 1. Check the power supply source. 2. Replace the +24V fuse on the PSU. 3. Replace the PSU
557	Zero cross frequency error
	The zero cross signal is detected ten times while the fusing lamp relay remains ON after turning on the main power.
	<ul style="list-style-type: none"> • Defective fusing lamp relay • Defective drive circuit of the fusing lamp relay • Unstable input power source <ol style="list-style-type: none"> 1. Check the power supply source. 2. Replace the fusing unit. <p>★ Important</p> <ul style="list-style-type: none"> • Execute "Fuser SC Reset" to recover the machine after completing the recovery procedure. Otherwise, the machine continues to issue this SC code and cannot be operated.

559	Fuser 3times jam error
	<p>The paper jam counter for the fusing unit reaches 3. The paper jam counter is cleared if the paper is fed correctly.</p> <p>This SC is activated only when this function is enabled with "Engine Maintenance" (default "OFF").</p>
	<ul style="list-style-type: none"> • Defective fusing unit • Defective fusing control <ol style="list-style-type: none"> 1. Clear this SC to send a command after a jam removal. 2. Turn off this function after a jam removal. <p>★ Important</p> <ul style="list-style-type: none"> • Execute "Fuser SC Reset" to recover the machine after completing the recovery procedure. Otherwise, the machine continues to issue this SC code and cannot be operated.

SC 6xx (Communication and Other Error)

6

669	EEPROM communication error
	An unexpected value exists in the initialization flag of the EEPROM
	<ul style="list-style-type: none"> • EEPROM not connected • Defective EEPROM <ol style="list-style-type: none"> 1. Installing the EEPROM. 2. Replacing the EEPROM.
688	CTL_PRREQ_N signal does not come.
	The ECB does not receive a memory address command from the controller 20 seconds after paper is in the position for registration.
	<ul style="list-style-type: none"> • Defective controller board • Communication error <ol style="list-style-type: none"> 1. Turn the machine's main power off, and then on. 2. Check if the controller board is firmly connected to the ECB.



Image Problems

Overview

Image problems may appear at regular intervals that depend on the circumference of certain components. The following diagram shows the possible symptoms (black or white dots at regular intervals).

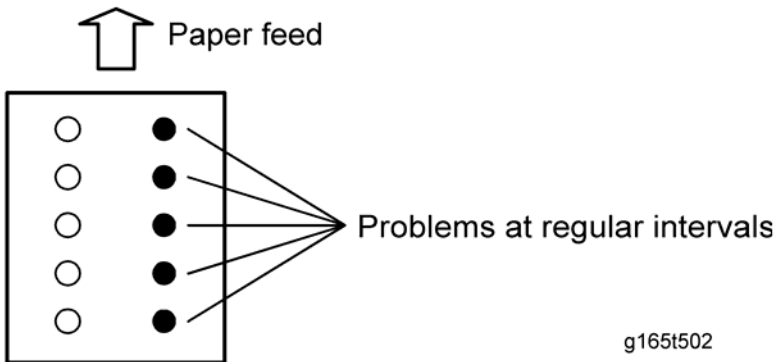

- Abnormal image at 29.8 mm intervals: Charge roller
- Abnormal image at 37.7 mm intervals: Registration roller
- Colored spots at 37.9 mm intervals: Print cartridge (Development roller)
- Abnormal image at 45.8 mm intervals: Transfer roller
- Colored spots at 75.3 mm intervals: Print cartridge (OPC drum)
- Abnormal image at 94.2 mm intervals: Fusing unit (Pressure roller)
- Abnormal image at 93.1 mm intervals: Fusing unit (Hot roller)
- Abnormal image at 100.5 mm intervals: Paper feed roller

Test Page Printing

When you check an image problem or other problems, it might be necessary to print a test page. Follow the test page print procedure below to print a test page.

Test Page Print Procedure

1. Press the "User Tools".
2. Press the "Up" or "Down" keys to select "PDL Settings" and then press the "OK" key.
3. Press the "Up" or "Down" keys to select "List Print" and then press the "OK" key.

4. Press the "Up" or "Down" keys to select "Test Page" and then press the "OK" key.
5. Press the "OK" key to print the test page to preview the settings.
 - Test page sample

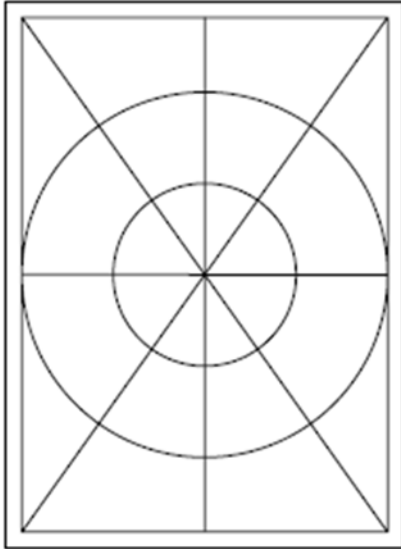

m016t501

6

Test Pattern Printing

Follow the test pattern print procedure below to print a test pattern.

Test Pattern Print Procedure

1. Enter the "Maintenance Mode".
2. Select "Engine Maintenance", and then press "OK" key.
3. Select "Test Pattern", and then press "OK" key.
4. The following three test pattern pages (Checker flag/ Grid pattern/ Trimming pattern) are printed.
 - Test pattern samples

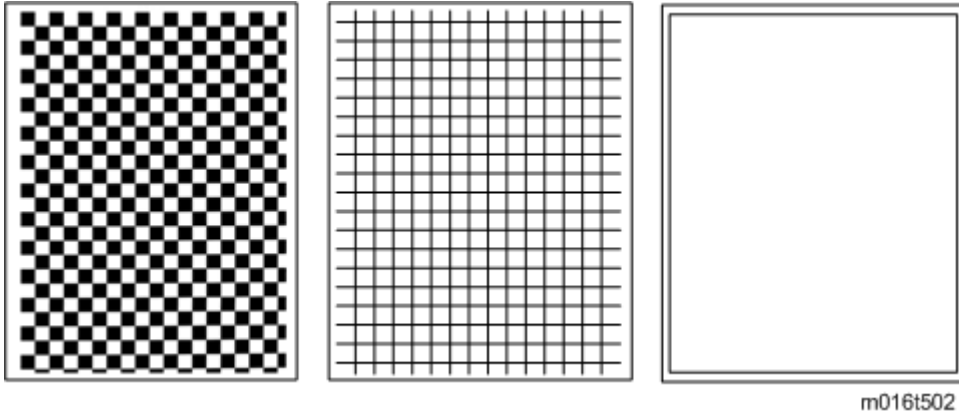

Dark lines in halftone areas at 75mm Intervals

6

Using the machine in a room where humidity level is too low may cause dark lines in halftone areas at 75mm intervals. This is because low-humidity conditions tend to cause variations in light sensitivity across the surface of the drum.

Selecting [On] for [Low Humidity Mode] under [Machine Settings] may help to prevent these lines from appearing.

When the humidity mode setting is enabled, the drum is rotated slightly every 15 minutes. This keeps the light sensitivity constant across the entire surface of the drum.

Jam

Jam Sensor Layout

There are the sensors of the jam detection as shown below.

Paper Jam

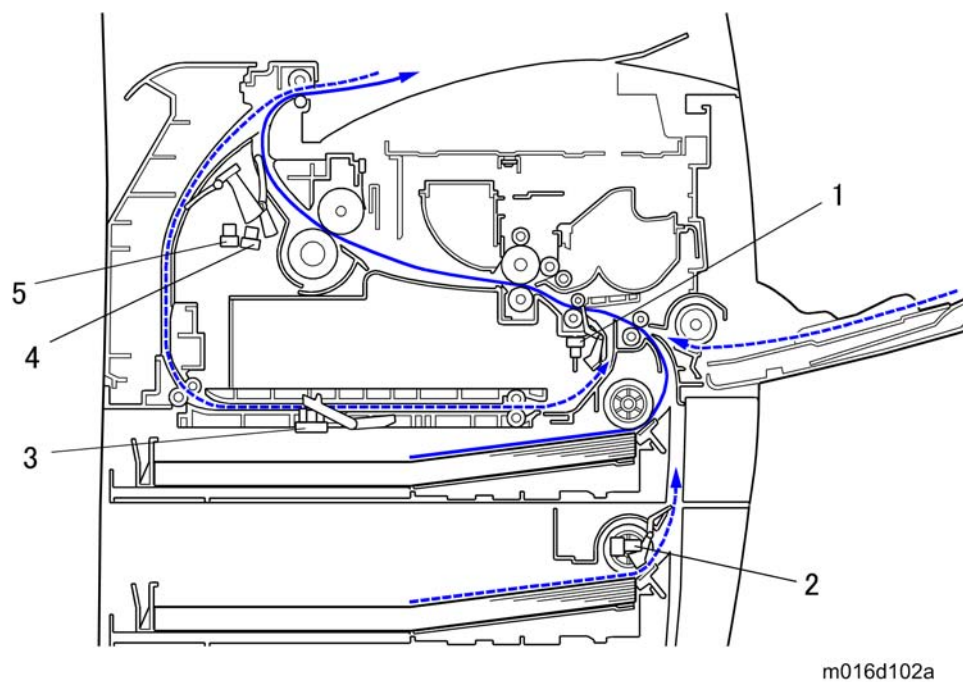

1. Registration Sensor
2. Tray2 Paper Feed Sensor
3. Inverter Sensor
4. Paper Exit Sensor
5. Relay Sensor

Original Jam

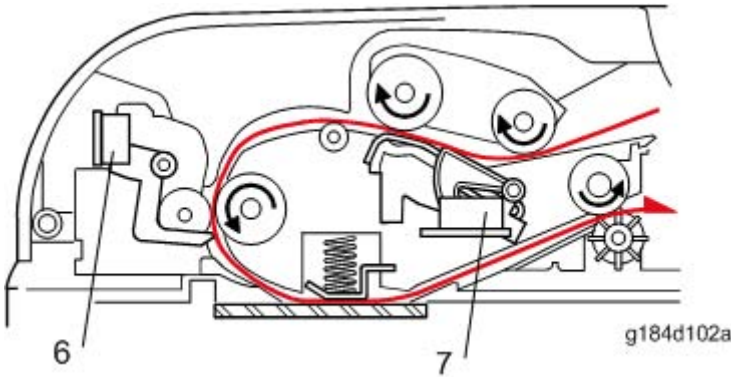

- 1. ADF Feed Sensor
- 2. Original Set Sensor

6

Jam Message List

Here is a list of common jam messages, a description of the causes.
See the drawing shown above to check the sensor location.

Paper Jam

Related to jam code

Jam message	Cause	Sensor
Bypass Tray Paper Misfeed Jam	Paper does not reach registration sensor (bypass tray)	Registration sensor [1]
Upper Misfeed Jam	Paper does not reach registration sensor (tray1)	Registration sensor [1]
Lower Misfeed Jam	Paper does not reach tray2 convey sensor	Tray2 paper feed sensor [2]
	Paper does not reach registration sensor	Registration sensor [1]

Duplex Jam Duplex Misfeed Jam	Paper does not reach registration sensor (duplex feed tray)	Registration sensor [1]
	Paper does not reach duplex entry sensor	Relay sensor [5]
	Paper does not reach duplex exit sensor	Inverter sensor [3]
Inner Jam	Paper stayed on registration sensor	Registration sensor [1]
	Paper does not reach exit sensor	Paper exit sensor [4]
Outer Jam	Paper stayed on exit sensor	Paper exit sensor [4]

Related to initialize jam

Jam message	Cause
Lower Misfeed Jam	Tray2 paper feed sensor [2]
Inner Jam	Registration sensor [1]
Outer Jam	Paper exit sensor [4]
Duplex Jam Duplex Misfeed Jam	Relay sensor [5]
	Inverter sensor [3]

Original Jam

Jam message	Cause
"ADF Jam Open ADF Cover and Clear Jam"	ADF Feed sensor [6] Original set sensor [7]

7. Energy Saving

Energy Save

Energy Saver Modes

Customers should use energy saver modes properly, to save energy and protect the environment.

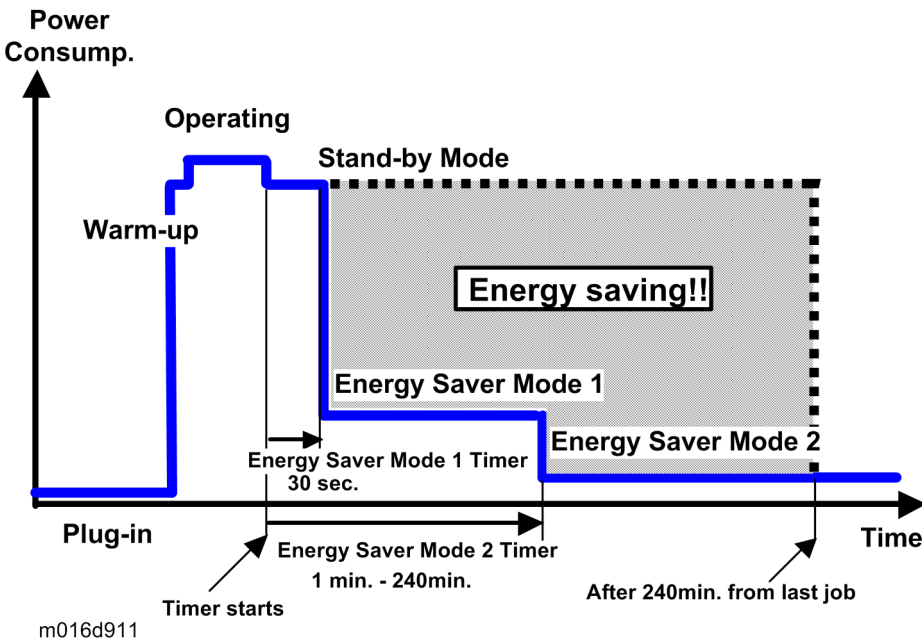

The backlight of the screen is turned off and "Energy Saver Mode1" appears on the screen, and then the fusing lamp is turned off and "Energy Saver Mode2" appears on the screen.

The area shaded grey in this diagram represents the amount of energy that is saved when the timers are at the default settings. If the timers are changed, then the energy saved will be different. For example, if the timers are all set to 240 min., the grey area will disappear, and no energy is saved before 240 min. expires.

Timer Settings

The user can set these timers with User Tools (Menu > Admin Settings > Power Saver > Energy Saver Mode 1 or Mode2)

- Energy Saver Mode1 (30 sec.): This can be only turned on or off.

- Energy Saver Mode2 (1 to 240 min.): This can be turned on or off and timer setting is adjustable (default: 1 min.).

Return to Stand-by Mode

Energy Saver Mode1

- Recovery time: 10 sec.

Energy Saver Mode2

- Recovery time: 23 sec.

Recommendation

We recommend that the default settings should be kept.

- If the customer requests that these settings should be changed, please explain that their energy costs could increase, and that they should consider the effects on the environment of extra energy use.
- If it is necessary to change the settings, please try to make sure that the Energy Saver Mode2 Timer is not too long. Try with a shorter setting first, such as 30 min., then go to a longer one (such as 60 min.) if the customer is not satisfied.
- If the timers are all set to the maximum value, the machine will not begin saving energy until 240 minutes has expired after the last job. This means that after the customer has finished using the machine for the day, energy will be consumed that could otherwise be saved.

Paper Save

Effectiveness of Duplex/Combine Function

Duplexing and the combine functions reduce the amount of paper used. This means that less energy overall is used for paper production, which improves the environment.

1. Duplex:

Reduce paper volume in half!



d062d102

7

2. Combine mode:

Reduce paper volume in half!



d062d100

3. Duplex + Combine:

Using both features together can further reduce paper volume by 3/4!



d062d101

To check the paper consumption, look at the total counter and the duplex counter.

The total counter counts all pages printed.

- For one duplex page, the total counter goes up by 2.
- For a duplex job of a three-page original, the total counter goes up by 3.

The duplex counter counts pages that have images on both sides.

- For one duplex page, the duplex counter goes up by 1.
- For a duplex job of a three-page original, the duplex counter will only increase by 1, even though two sheets are used.

7

Total counter

This machine has a total sides printed counter only (so a duplex print is counted as two, not one). You can check the total counter in the "Maintenance Mode" or on the "Maintenance Page".

- Total counter: "Maintenance Mode" > "Engine Maintenance" > "Total Counter In" or "Maintenance Page"

The following table shows paper savings and how the counters increase for some simple examples of single-sided and duplex jobs

Duplex mode:

Originals	Simplex Sheet used	Duplex Sheets used	Paper Saved	Total counter
1	1	1	0	1
2	2	1	1	2
3	3	2	1	3
4	4	2	2	4
5	5	3	2	5

Originals	Simplex Sheet used	Duplex Sheets used	Paper Saved	Total counter
10	10	5	5	10
20	20	10	10	20

If combine mode is used, the total and duplex counters work in the same way as explained previously. The following table shows paper savings and how the counters increase for some simple examples of duplex/combine jobs.

2 in 1 mode:

Originals	Simplex Sheet used	Duplex Sheets used	Paper Saved	Total counter
1	1	1	0	1
2	2	1	1	1
3	3	2	1	2
4	4	2	2	2
5	5	3	2	3
10	10	5	5	5
20	20	10	10	10

Duplex + 2 in 1 mode:

Originals	Simplex Sheet used	Duplex Sheets used	Paper Saved	Total counter
1	1	1	0	1
2	2	1	1	1
3	3	1	2	2
4	4	1	3	2
5	5	2	3	3
6	6	2	4	3
7	7	2	5	4

Originals	Simplex Sheet used	Duplex Sheets used	Paper Saved	Total counter
8	8	2	6	4
9	9	3	6	5
10	10	3	7	5
11	11	3	8	6
12	12	3	9	6

**Model RN-MF1
Machine Codes: M016/M017
Appendices**

30 November, 2009

TABLE OF CONTENTS

1. Appendix: Specifications

General Specifications.....	3
General Specifications.....	3
Printer.....	5
Copier.....	6
Scanner.....	7
Fax.....	7
Supported Paper Sizes.....	10

2. Appendix: SP Mode Tables

Service Menu.....	13
-------------------	----

3. Appendix: Troubleshooting Guide

Service Call Conditions.....	15
Error Messages.....	16
Overview.....	16
Error Messages List.....	16
Fax Error Code.....	18



1. Appendix: Specifications

General Specifications

General Specifications

Configuration	Desktop	
Paper capacity	Main tray	250 sheets (80g/m ²) 100 postcards
	By-pass tray	50 sheets (80g/m ²) 8 envelopes 20 postcards
	Optional paper feed unit	Plain paper: 250 sheets (80g/m ²)
	Output tray	Face down: 125 sheets
Paper size	Main tray	A4, A5, Letter, Legal, B5, HLT, A6, Executive, Postcard Custom size: Max: 216 x 356mm (8.5 x 14 inch) Min: 100 x 148mm (3.937 x 5.8 inch)
	By-pass tray	A4, A5, A6, Letter, Legal, HLT, Executive, Postcard, B5, Envelope Custom size: Max.: 216 x 356mm (8.5 x 14 inch) Min.: 90 x 148mm (3.5 x 5.8 inch)
	Duplex	A4, Letter, Legal
	Optional paper feed unit	A4, LT, LG, B5, HLT, A5

Paper weight	Main tray	52-162 g/m ² (14-43 lb)
	By-pass tray	52-162 g/m ² (14-43 lb)
	Optional paper feed unit	60-105 g/m ² (16-28 lb) A setting for outside of normal specifications paper (60 g/m ² - 105 g/m ²) is provided. With this setting, it may be possible to print properly on outside of normal specifications paper.
ADF	Paper weight	52-105 g/m ² (14-28 lb)
	Capacity	35 sheets
	Width	139.7 to 216mm (5.5 to 8.5 inch)
	Length	139.7 to 355.6mm (5.5 to 14 inch)
Machine size (W x D x H)	420 x 397 x 442 mm (16.5 x 15.6 x 17.4 inch) Without Option	
Weight	M016: 17.1 Kg(37.7 lb) M017: 18.0 Kg(39.7 lb) • With a starter AIO cartridge.	
Energy Saver Mode	Selectable 1 to 240 minutes (1 minute steps)	
Power consumption	Maximum	NA/TW: Less than 850 W (energy star compliant) EU/AP/CN: Less than 895 W (energy star compliant)
	Ready mode	120W
	Power save mode	70 W (energy saver mode 1) 10 W (energy saver mode 2)
Power	NA	120 V, 60Hz ± 3Hz
	TW	110 V, 60Hz ± 3Hz
	EU/AP/CN	220 - 240 V, 50/60Hz ± 3Hz

Noise	Printing	Less than 65.8 dB (A)
	Standby Mode	Less than 40 dB (A)
	Energy Save Mode	Less than 40 dB (A)
Warm up time	Less than 30 seconds	
Machine life	5 years, 200,000 prints (whichever comes first)	
Environmental Standard	Energy star program (M017)	
Laser type	Class IIIB	

Printer

Print speed	Simplex	30 ppm LT, 28 ppm A4 (600 dpi)
	Duplex (M017 only)	15 ppm LT, 14 ppm A4 (600 dpi)
Printer drivers	PCL, PS3	
Font	80 fonts	
Resolution	Normal	600 x 600 dpi
	RET	1200 x 600 dpi
Toner save mode	Supported	
Warm-up time	Less than 30 seconds	
First print time	Less than 8 seconds	
Duplex print	Supported (M017 only)	
Interface option	USB 2.0, 10/ 100 Base - TX	
Network	Protocol	TCP/IP, IPP
Memory	Standard	128MB
Operation System	PCL: Windows XP, 2000/2003server, Vista, Windows 2008 server PS3: Windows XP, 2000/2003server, Vista, Windows 2008 server Macintosh 10.2.8 -	

Copier

1st copy speed		Less than 12 sec.	
Maximum original size		Flatbed	A4 (210 x 297mm) / Letter (215.9 x 279.4mm)
		ADF	A4 (210 x 297mm) / Letter (215.9 x 279.4mm) / Legal (215.9 x 355.6mm)
Copy Speed	Single Document	Flatbed	28 cpm (A4), 30 cpm (LT)
	Multiple Copy	ADF	28 cpm (A4), 30 cpm (LT)
	Multiple Document Single Copy	ADF	20 cpm
Multiple copy		Up to 99	
Resolution (H x V)		Scanning	600 x 600 dpi (Flatbed), 600 x 300 dpi (ADF)
		Printing	600 x 600 dpi
Grayscale		256 levels	
Reduction / Enlargement		Fix	NA: 50, 65, 78, 93, 129, 155, 200, 400% EU: 50, 71, 82, 93, 122, 141, 200, 400%
		Custom	25 - 400% in 1% steps
Copy mode		Text/ Photo/ Mixed	
Memory copy		Yes	
Duplex copy		Yes (M017 only)	
Interrupt copy		No	
Combine copy		2 in 1, 4 in 1 (ADF only for A4/ LT)	
APS/ AMS		No/No	
Auto Tray Switch		No	
Directional Magnification		No	
Directional Size Magnification		No	

Photo Mode	Yes
Auto Start	No
User Program	No
Electronic Sorting	Standard (collation, ADF only), Max. A4/ LT, LG
Image Rotation	No
Series Copy	No

Scanner

Scanning Device	CCD array image-sensor	
Resolution	Scanner: 1200 x 1200 dpi	
	Driver: Max. 19200 x 19200 dpi (interpolated)	
Gray scale	256 levels	
Scan modes/ speed (A4, 200dpi, Compression)	Less than 5 sec.	
Maximum original size	Platen	Width max: Up to 216mm, Length max: Up to 297mm
	ADF	Width max: Up to 216mm, Length max: Up to 356mm
Scan Depth	48 bits color processing (input), 24 bits color processing (output)	
PC Interface	USB2.0, 10/100Base-TX	
TWAIN Compliment	TWAIN, WIA	
Scanner utilities and Drivers	TWAIN Driver, Scanner utility (PageManager)	

Fax

Network	PSTN/ PBX
Compatibility	T30 (ITU-T Super G3)
Transmission Speed	Approx. 3sec

Coding system	MH/MR/MMR	
Contrast control	3 Level	
Telephone Connection	Standard: One connection	
Answering Machine Interface	Standard	
Monitor Speaker	3 Level	
Document size	ADF Width	139.7 to 215.9mm (5.5" to 8.5")
	ADF Length	139.7 to 355.6mm (5.5" to 14")
	Flatbed Width	216mm
	Flatbed Length	297mm
Scanning width	Max. 210 mm (8.3")	
Printing width	Max. 208 mm (8.2")	
Gray scale	256 levels	
Polling type	None	
Resolution	Standard: 200dpi x 100dpi (8 dot/mm x 3.85 line/mm) Fine/Photo: 200dpi x 200dpi (8 dot/mm x 7.7 line/mm)	
Scanning Speed	Less than 5 sec. (A4 SEF, 200 dpi)	
Modem Speed	Automatic Fallback: 33600, 31200, 28800, 26400, 24000, 21600, 19200, 16800, 14400, 12000, 9600, 7200, 4800, 2400bps	
SAF Memory	100 pages (ITU No.1 chart)	
Memory Backup	1 hour	
One-touch dial	20	
Abbreviated dial	50	
Broadcasting	100 stations	
Communication source	Public switched telephone network	
PC Fax utility	Available	
Automatic re-dial	Available	

Auto Answer	3-5 rings (Default 3 rings)
-------------	-----------------------------

Supported Paper Sizes

A	Supported, with size molded into tray. Need to select paper size by operation panel/driver.
B	Supported but size is not molded into tray. Need to select paper size by operation panel/driver.
C	Need to input paper size by operation panel and driver.
N	Not supported.

Type	SEF/ LEF	Size	Input Tray			Auto Duplex
			Standard Tray	Option PFU	Bypass Tray	
A4	SEF	210x297	A	A	B	C
B5	SEF	182x257	A	A	B	N
A5	SEF	148x210	A	A	B	N
	LEF	210x148	N	N	C	N
B6	SEF	128x182	B	N	B	N
	LEF	182x128	N	N	N	N
A6	SEF	105x148	B	N	B	N
	LEF	148x105	N	N	N	N
Postcard	SEF	100 x 148	C	N	C	N
	LEF	148 x 100	N	N	N	N
	SEF	200 x 148	C	N	C	N
	LEF	148 x 200	C	N	N	N
Legal	SEF	8 $\frac{1}{2}$ "x14"	A	A	B	B
Letter	SEF	8 $\frac{1}{2}$ "x11"	A	A	B	B
Half Letter	SEF	5 $\frac{1}{2}$ " x 8 $\frac{1}{2}$ "	B	B	B	N
	LEF	8 $\frac{1}{2}$ " x 5 $\frac{1}{2}$ "	N	N	N	N

Type	SEF/ LEF	Size	Input Tray			Auto Duplex
			Standard Tray	Option PFU	Bypass Tray	
Executive	SEF	7 ¹ / ₄ "x10 ¹ / ₂ "	A	N	B	Y
F	SEF	8" x 13"	B	N	B	N
Foolscap	SEF	8 ¹ / ₂ " x 13"	B	N	B	N
Folio	SEF	8 ¹ / ₄ " x 13"	B	N	B	N
16 Kai	SEF	195 x 267	B	N	B	N
Env. #10	SEF	4 ¹ / ₈ " x 9 ¹ / ₂ "	N	N	B	N
Env. Monarch	SEF	3 ⁷ / ₈ " x 7 ¹ / ₂ "	N	N	B	N
Env. C5	SEF	162 x 229	N	N	B	N
Env. C6	SEF	114 x 162	N	N	B	N
Env. DL	SEF	110 x 220	N	N	B	N
	Width	100-216mm	C	N	C	N
	Length	148-156mm	C	N	C	N
	Width	90-216mm	N	N	C	N
	Length	140-356mm	N	N	C	N

2. Appendix: SP Mode Tables

Service Menu

See "Main Chapters" for "Service Program Mode".

3. Appendix: Troubleshooting Guide

Service Call Conditions

See "Main Chapters" for "Service Call Conditions".

Error Messages

Overview

Error codes will be displayed on the LCD panel if the machine has a problem. These can be viewed by a customer.

3

Error Messages List

000	Cover Open
	The front or top cover is open.
	<ol style="list-style-type: none"> 1. Close the front or top cover. 2. Replace the interlock switches or actuator mechanism.
010	AIO Set Error
	<ul style="list-style-type: none"> • Black AIO not set • Defective connection of the ID chip terminal on the (black) AIO
	<ol style="list-style-type: none"> 1. Install the AIO. 2. Reinstall or replace the AIO.
014	Waste Toner Bottle Set Error
	<ul style="list-style-type: none"> • Waste toner bottle not set • Disconnected or defective harness of the waste toner bottle set sensor • Defective waste toner bottle set sensor
	<ol style="list-style-type: none"> 1. Install the waste toner bottle. 2. Check or replace the harness of the waste toner bottle set sensor. 3. Replace the waste toner bottle set sensor.

030	Tray/Paper Selection Error
	<ul style="list-style-type: none"> No paper in the tray or tray not set in the machine Paper size requested by the job does not match the paper in the tray
	<ol style="list-style-type: none"> Install the tray or put the correct size paper in the tray. Check the paper setting in the user menu mode.
031	Paper Selection Error: Feed and Exit
	<ul style="list-style-type: none"> Paper size requested by the job does not match the paper in the tray Selection error for the paper feed and paper exit location in duplex mode
	Check the paper feed and exit location in the user menu mode.
050	Jam Error: No Feed from Tray 1
	<ul style="list-style-type: none"> Paper slipped
	Remove the paper jam at tray 1.
052	Jam Error: No Feed from Optional Tray
	<ul style="list-style-type: none"> Paper slipped
	Remove the paper jam at the optional tray (Tray 2).
055	Inner Jam Error: Registration/ Paper Exit
	A sheet of paper stays at the registration sensor or paper exit sensor.
	<ul style="list-style-type: none"> Paper slipped Paper double feed
Remove the paper jam at the registration sensor or paper exit sensor.	

3

056	Paper Exit Jam Error: Paper Exit/ Fusing Unit
	A sheet of paper stays at the paper exit sensor or winds around the rollers in the fusing unit. <ul style="list-style-type: none"> • Paper slipped • A sheet of paper is wound around the rollers in the fusing unit
	Remove the paper jam at the paper exit sensor or in the fusing unit.

070	Printing Error: No Paper
	<ul style="list-style-type: none"> • No paper in the tray
	Put paper in the tray.

080	Toner Near End: Black AIO
081	Toner End: Black AIO
	<ul style="list-style-type: none"> • Black toner near-end or end
	Replace the black AIO.

088	Waste Toner Bottle: Near Full
089	Waste Toner Bottle: Full
	<ul style="list-style-type: none"> • Waste toner bottle near-full or full
	Replace the waste toner bottle.

Fax Error Code

This section describes the dial, transmission (TX), and reception (RX) error codes that are printed on the TX Report/Activity Report.

Basic error code structure

Error codes consist of six hexadecimal digits (0–5).

Digit 5 (far left)	TX or RX
TX:	1xxxxx

Digit 5 (far left)	TX or RX
RX:	2 xxxxx

Digit 4	Coding (MH/MR/MMR)
MH:	x 1 xxxx
MR:	x 2 xxxx
MMR:	x 3 xxxx

Digit 3	MODEM mode
V27ter nonECM:	xx 1 xxx
V29 nonECM:	xx 2 xxx
V17 nonECM:	xx 3 xxx
V33 nonECM:	xx 4 xxx
V34:	xx 5 xxx
V27ter ECM:	xx 9 xxx
V29 ECM:	xx a xxx
V17 ECM:	xx b xxx
V33 ECM	xx c xxx

Digit 2	MODEM speed
2400:	xxx 1 xx
4800:	xxx 2 xx
7200:	xxx 3 xx
9600:	xxx 4 xx
12000:	xxx 5 xx
14400:	xxx 6 xx
16800:	xxx 7 xx

Digit 2	MODEM speed
19200:	xxx 8 xx
21600:	xxx 9 xx
24000:	xxx a xx
26400:	xxx b xx
28800:	xxx c xx
31200:	xxx d xx
33600:	xxx e xx

Error code table

Error Type		Error Description	Error Code
General		Normal (No Error)	0
		STOP	xxxx01
		H/W Error	Xxxx1f
		RX T1 Time Out	Not logged in activity report
		Scanner Error during TX	1xxx11
		Memory Full during RX	2xxx14
TX Job Error		TX Job Lost	1xxx18
		TX Job deleted	1xxx19
Dial failure		Connection Fail	xxxx21
		Dial Fail	xxxx22
		Redial All Failed	xxxx23

Error Type		Error Description	Error Code
Comm. Error	1. Phase-B Error	TX T1 Time Out	xxxx31
		V8 negotiation Fail	xxxx32
		Retry Out	xxxx40
		Too many FTT	xxxx41
		Too many CRP	xxxx42
		T2 Time Out	xxxx43
		DCN received	xxxx44
		Command Rec Error	xxxx45
		Resp Rec Error	xxxx46
		Invalid Command/Response RX	xxxx47
		Remoter No RX capability	xxxx48
		T1 time out after EOM	xxxx49
	2. Phase-C Error	T2 Time Out	xxxx50
		Image Data not ready	xxxx51
		Phase-C Time Out	xxxx52

Error Type		Error Description	Error Code
	3. Phase-D Error	Retry Out	xxxx60
		T2 Time Out	xxxx61
		DCN received	xxxx62
		Too many CRP	xxxx63
		Too many PPR	xxxx64
		RNR time Out	xxxx65
		RTN/PIN Received, EOR/ERR/DCN	xxxx66
		Invalid Command/Response RX	xxxx67
		Command Rec Error	xxxx68
		Resp Rec Error	xxxx69
	4. Phase-E Error	Time Out	xxxx70
	5. Other general Comm Error	modem hang-up	xxxx80
		V34 abort received	xxxx81
		V34 t1 timeout, control channel error	xxxx82
		V34 t1 timeout, primary channel error	xxxx83

Free Manuals Download Website

<http://myh66.com>

<http://usermanuals.us>

<http://www.somanuals.com>

<http://www.4manuals.cc>

<http://www.manual-lib.com>

<http://www.404manual.com>

<http://www.luxmanual.com>

<http://aubethermostatmanual.com>

Golf course search by state

<http://golfingnear.com>

Email search by domain

<http://emailbydomain.com>

Auto manuals search

<http://auto.somanuals.com>

TV manuals search

<http://tv.somanuals.com>