



# FAX Option Type 3245

## Operating Instructions Facsimile Reference <Advanced Features>



- 
- 1 Transmission Mode
  - 2 Checking and Canceling Transmission Files
  - 3 Communication Information
  - 4 Other Transmission Features
  - 5 Reception Features
  - 6 Fax via Computer
  - 7 Simplifying the Operation
  - 8 Facsimile Features
  - 9 Administrator Setting
  - 10 Solving Operation Problems
  - 11 Appendix

Read this manual carefully before you use this machine and keep it handy for future reference. For safe and correct use, be sure to read the Safety Information in the "General Settings Guide" before using the machine.

## Introduction

This manual contains detailed instructions and notes on the operation and use of this machine. For your safety and benefit, read this manual carefully before using the machine. Keep this manual in a handy place for quick reference.

## Notes

Some illustrations in this manual might be slightly different from the machine.

Certain options might not be available in some countries. For details, please contact your local dealer.

Two kinds of size notation are employed in this manual. With this machine refer to the inch version.

## Important

Contents of this manual are subject to change without prior notice. In no event will the company be liable for direct, indirect, special, incidental, or consequential damages as a result of handling or operating the machine.

## Trademarks

Microsoft®, Windows® and Windows NT® are registered trademarks of Microsoft Corporation in the United States and/or other countries.

Adobe® and Acrobat® are registered trademarks of Adobe Systems Incorporated.

Ethernet is a registered trademark of Xerox Corporation.

Other product names used herein are for identification purposes only and might be trademarks of their respective companies. We disclaim any and all rights to those marks.

## Note

The proper names of the Windows operating systems are as follows:

- The product name of Windows® 95 is Microsoft® ScanRouter.
- The product name of Windows® 98 is Microsoft® Windows 98.
- The product name of Windows® Me is Microsoft® Windows Millennium Edition (Windows Me).
- The product names of Windows® 2000 are as follows:  
Microsoft® Windows® 2000 Advanced Server  
Microsoft® Windows® 2000 Server  
Microsoft® Windows® 2000 Professional
- The product names of Windows® XP are as follows:  
Microsoft® Windows® XP Professional  
Microsoft® Windows® XP Home Edition
- The product names of the Windows Server™ 2003 are as follows:  
Microsoft® Windows Server™ 2003 Standard Edition  
Microsoft® Windows Server™ 2003 Enterprise Edition  
Microsoft® Windows Server™ 2003 Web Edition
- The product names of Windows NT® 4.0 are as follows:  
Microsoft® Windows NT® Server 4.0
- Microsoft® Windows NT® Workstation 4.0

# Manuals for This Machine

The following manuals describe the operational procedures of this machine. For particular functions, see the relevant parts of the manual.

## **Note**

- Manuals provided are specific to machine type.
- Adobe Acrobat Reader/Adobe Reader is necessary to view the manuals as a PDF file.
- Two CD-ROMs are provided:
  - CD-ROM 1“Operating Instructions”
  - CD-ROM 2“Scanner Driver and Document Management Utility”

## ◆ **General Settings Guide**

Provides an overview of the machine and describes System Settings (such as Tray Paper Settings), Document Server functions, and troubleshooting. Refer to this manual for Address Book procedures such as registering fax numbers, e-mail addresses, and user codes.

## ◆ **Security Reference**

This manual is for administrators of this machine. It describes security functions that the administrators can use to protect data from being tampered, or prevent the machine from unauthorized use. Also refer to this manual for the procedures for registering administrators, as well as setting user and administrator authentication.

## ◆ **Network Guide (PDF file - CD-ROM1)**

Provides information about configuring and operating the printer in a network environment or using software. This manual covers all models, and therefore contains functions and settings that may not be available for your model. Images, illustrations, functions, and supported operating systems may differ from those of your model.

## ◆ **Copy Reference**

Describes operations, functions, and troubleshooting for the machine’s copier function.

## ◆ **Facsimile Reference <Basic Features>**

Describes operations, functions, and troubleshooting for the machine’s facsimile function.

## ◆ **Facsimile Reference<Advanced Features>(this manual)**

Describes advanced facsimile functions such as line settings and procedures for registering IDs.

## ◆ **Printer Reference**

Describes system settings, operations, functions, and trouble shooting for the machine’s printer function.

❖ **Scanner Reference (PDF file - CD-ROM1)**

Describes operations, functions, and troubleshooting for the machine's scanner function.

❖ **Manuals for DeskTopBinder Lite**

DeskTopBinder Lite is a utility included on the CD-ROM labeled "Scanner Driver and Document Management Utility".

- DeskTopBinder Lite Setup Guide (PDF file - CD-ROM2)  
Describes installation of, and the operating environment for DeskTopBinder Lite in detail. This guide can be displayed from the **[Setup]** dialog box when DeskTopBinder Lite is installed.
- DeskTopBinder Introduction Guide (PDF file - CD-ROM2)  
Describes operations of DeskTopBinder Lite and provides an overview of its functions. This guide is added to the **[Start]** menu when DeskTopBinder Lite is installed.
- Auto Document Link Guide (PDF file - CD-ROM2)  
Describes operations and functions of Auto Document Link installed with DeskTopBinder Lite. This guide is added to the **[Start]** menu when DeskTopBinder Lite is installed.

❖ **Other manuals**

- PostScript 3 Supplement (PDF file - CD-ROM1)
- Unix Supplement (Available from an authorized dealer, or as a PDF file on our Web site.)

 **Note**

- The following software products are referred to using a general names:
  - DeskTopBinder Lite and DeskTopBinder Professional → DeskTopBinder
  - ScanRouter V2 Lite and ScanRouter EX Professional (optional) → the ScanRouter delivery software
  - SmartDeviceMonitor for Admin and SmartDeviceMonitor for Client → SmartDeviceMonitor for Admin/Client

# TABLE OF CONTENTS

**Manuals for This Machine** ..... i  
**How to Read This Manual** ..... 1  
    Symbols ..... 1

## 1. Transmission Mode

---

**Sending at a Specific Time (Send Later)** ..... 3  
**Sender Settings**..... 5  
**Priority Transmission** ..... 8  
**Confidential Transmission**..... 9  
**Polling Transmission**..... 11  
    Polling Transmission Clear Report..... 13  
**Polling Reception**..... 14  
    Polling Reserve Report ..... 16  
    Polling Result Report ..... 16

## 2. Checking and Canceling Transmission Files

---

**Displaying Confirmation of Transmission**..... 18  
**Canceling a Transmission** ..... 19  
**Deleting a Destination** ..... 20  
**Adding a Destination** ..... 21  
**Changing the Transmission Time** ..... 22  
**Printing a File** ..... 23  
**Resending a File** ..... 24  
**Printing a List of Files in Memory (Print TX File List)**..... 25

## 3. Communication Information

---

**Printing the Journal** ..... 27  
    Journal ..... 29  
**Checking the Transmission Result (TX File Status)**..... 31  
**Checking the Reception Result (RX File Status)** ..... 32  
**Displaying the Memory Status**..... 33  
**Printing/Deleting Received and Stored Documents (Print/Delete Stored RX File)**... 34  
    Printing Received and Stored Documents ..... 34  
    Deleting Received and Stored Documents ..... 35  
**Printing a Confidential Message** ..... 36  
    Confidential File Report..... 37  
**Printing a File Received with Memory Lock**..... 38  
**Personal Boxes** ..... 40  
    Personal Boxes ..... 40  
    Printing Personal Box Messages ..... 41  
**Information Boxes** ..... 42  
    Information Boxes ..... 42  
    Storing Messages in Information Boxes ..... 42  
    Printing Information Box Messages ..... 44  
    Deleting Information Box Messages ..... 45

## 4. Other Transmission Features

<b>Handy Dialing Functions</b> .....	<b>47</b>
Chain Dial.....	47
(Example) 01133-1-555333.....	47
Redial.....	47
<b>Advanced Features</b> .....	<b>49</b>
SUB Code.....	49
SID Code.....	50
SEP Code.....	50
PWD Code.....	51
Transfer Request.....	52
With transfer requests set in the system settings.....	55
<b>On Hook Dial</b> .....	<b>56</b>
<b>Manual Dial</b> .....	<b>58</b>
<b>Changing the Line Port</b> .....	<b>59</b>
<b>Sub Transmission Mode</b> .....	<b>61</b>
Book Fax.....	61
Two-Sided Transmission (Double-Sided Transmission).....	62
Standard Message Stamp.....	64
Sending an Auto Document.....	65
Printing documents stored as Auto Documents.....	66
Sending a Stored File.....	67
Sending stored documents.....	67
Printing stored documents.....	70
Stamp.....	72
Transmission Options.....	73
Fax Header Print.....	73
Label Insertion.....	73
Reduced Image Transmission.....	74
Auto Reduce.....	74
Default ID Transmission.....	74
Selecting transmission options for a single transmission.....	75
<b>More Transmission Functions</b> .....	<b>77</b>
If Memory Runs Out While Storing an Original.....	77
Parallel Memory Transmission.....	77
Checking the Transmission Result.....	78
Automatic Redial.....	78
Batch Transmission.....	78
Dual Access.....	78
Transmission with Image Rotation.....	79
Simultaneous Broadcast.....	79
JBIG Transmission.....	79
Transmitting Journal by E-mail.....	80
Journal by E-mail.....	80
<b>Printed Report</b> .....	<b>81</b>
Memory Storage Report.....	81
Communication Result Report (Memory Transmission).....	81
Communication Failure Report.....	82
Immediate TX Result Report (Immediate Transmission).....	82

## 5. Reception Features

---

<b>Reception</b> .....	<b>83</b>
Immediate Reception .....	83
Memory Reception .....	83
Substitute Reception .....	85
Receiving messages unconditionally.....	85
Receiving messages according to parameter-specified settings.....	86
<b>Reception Functions</b> .....	<b>87</b>
Transfer Station.....	87
Transfer Result Report .....	88
Transfer Result Report (transfer request by e-mail) .....	89
Forwarding Received Documents .....	90
Routing Received Documents with SUB Code .....	91
Transferring Received Documents.....	91
SMTP Reception Using Internet Fax.....	92
Routing E-mail Received via SMTP .....	93
JBIG Reception .....	95
Auto Fax Reception Power-up .....	95
<b>Printing Options</b> .....	<b>96</b>
Print Completion Beep .....	96
Checked Mark.....	96
Center Mark .....	96
Reception Time .....	97
Two-Sided Printing.....	97
180-Degree Rotation Printing .....	98
Multi-copy Reception.....	98
Image Rotation.....	99
Combine Two Originals.....	99
Page Separation and Length Reduction .....	100
Reverse Order Printing .....	100
Page Reduction.....	101
TSI Print (Transmitting Subscriber Identification Print) .....	101
When There Is No Paper of the Correct Size.....	101
Setting priority trays.....	102
Just size printing.....	103
Having Incoming Messages Printed on Paper from the Bypass Tray .....	103
<b>Where Incoming Message are Delivered - Output Tray</b> .....	<b>105</b>
Specifying Tray for Lines.....	105
Tray Shift.....	105

## 6. Fax via Computer

---

<b>Sending Fax Documents from Computers</b> .....	<b>107</b>
Before Use .....	108
Installing the Software.....	108
Auto run program.....	108
Installing individual applications .....	109
Applications Stored on the CD-ROM .....	109
LAN-Fax Driver.....	109
Address Book .....	110
LAN-Fax Cover Sheet Editor .....	110

Setting LAN-Fax Driver Properties .....	110
Setting Print Properties .....	110
Making Settings for Option Configuration .....	111
Basic Transmission .....	112
Specifying options .....	114
Confirming Transmission Results by E-mail .....	116
LAN-Fax Result Report .....	118
Printing and Saving .....	118
Editing Address Book .....	118
Editing Fax Cover Sheets .....	121
Creating a cover sheet .....	121
Attaching a created cover sheet .....	121
LAN-Fax Operation Messages .....	122
<b>Viewing Fax Information Using a Web Browser .....</b>	<b>123</b>
Viewing, Printing, and Deleting Received Fax Messages Using a Web Image Monitor ...	123
Viewing received fax messages using a Web browser .....	123
Printing fax information using a Web browser .....	124
Deleting fax information using a Web browser .....	124
Programming Destination Information from Web Browser .....	125
<b>Delivering Files Received by Fax .....</b>	<b>127</b>

## 7. Simplifying the Operation

---

<b>Programs .....</b>	<b>129</b>
Registering and Changing Keystroke Programs .....	129
Registering a priority function using a program .....	130
Changing a program name .....	131
Deleting a Program .....	131
Using a Program .....	132
<b>Using the Document Server .....</b>	<b>133</b>
Storing a Document .....	134
Changing Information of Stored Documents .....	136
Deleting a Stored Document .....	138
Managing Documents Saved in the Document Server from a Computer .....	139
Using DeskTopBinder .....	139
Using a Web browser .....	139

## 8. Facsimile Features

---

<b>Function List .....</b>	<b>141</b>
<b>Accessing User Tools (Facsimile Features) .....</b>	<b>144</b>
Quitting Default Settings .....	144
General Settings/Adjustment .....	144
Reception Settings .....	147
E-mail Settings .....	148
IP-Fax Settings .....	150



## 9. Administrator Setting

<b>Administrator Tools List .....</b>	<b>155</b>
<b>Using Administrator Settings .....</b>	<b>157</b>
Programming, Changing, and Deleting Standard Messages .....	157
Storing, Changing, and Deleting an Auto Document .....	158
Deleting an Auto Document.....	159
Programming, Changing and Deleting a Scan Size .....	160
Deleting a scan size .....	161
Printing Journal .....	162
Counters.....	162
Forwarding .....	162
Programming an End Receiver .....	163
Quitting the forwarding function.....	164
Forwarding Mark.....	164
Memory Lock.....	165
ECM (Error Correction Mode) .....	165
User Parameters .....	166
Changing the User Parameters .....	170
Printing the User Parameter List .....	171
Special Senders to Treat Differently .....	171
Authorized Reception .....	172
Forwarding.....	173
Reception File Print Quantity.....	173
Print 2 Sided.....	173
Memory Lock .....	174
Reception Reverse Printing.....	174
Paper Tray.....	174
Programming/Changing Special Senders .....	174
Programming Initial Set Up of a Special Sender .....	178
Deleting a Special Sender .....	180
Printing the Special Sender List .....	180
Box Settings .....	180
Programming/changing Personal Boxes .....	181
Deleting Personal Boxes .....	183
Programming/changing Information Boxes .....	184
Deleting Information Boxes .....	185
Programming/changing Transfer Boxes .....	186
Deleting Transfer Boxes .....	189
Printing the Box List.....	190
Transfer Report .....	190
Programming a Confidential ID .....	191
Programming a Polling ID .....	192
Programming a Memory Lock ID .....	192
Selecting Dial/Push Phone.....	193
Storing or Printing Received Documents .....	193
Reception Report e-mail.....	194
Setting a User for Viewing Received and Stored Documents .....	195
Menu Protection Settings .....	196

## 10.Solving Operation Problems

---

<b>When an Error Report is Printed .....</b>	<b>197</b>
<b>Turning Off the Main Power / When a Power Failure Occurs .....</b>	<b>198</b>
<b>When an Error Occurs Using Internet Fax .....</b>	<b>199</b>
Error Mail Notification .....	199
Error Report (E-Mail).....	199
Server-Generated Error E-mail .....	199

## 11.Appendix

---

<b>Connecting the Machine to a Telephone Line and Telephone .....</b>	<b>201</b>
Connecting the Telephone Line .....	201
Selecting the Line Type.....	202
Connecting the Optional Handset or an External Telephone.....	202
<b>Optional Equipment.....</b>	<b>204</b>
Expansion Memory (32MB: DIMM) .....	204
Handset.....	204
Extra G3 Interface Unit .....	204
<b>Specifications.....</b>	<b>205</b>
Compatible Machines.....	207
Acceptable Types of Originals .....	208
Acceptable original sizes .....	208
Paper size and scanned area .....	208
Original sizes difficult to detect.....	210
<b>Maximum Values.....</b>	<b>212</b>
<b>INDEX.....</b>	<b>213</b>

# How to Read This Manual

---

## Symbols

---

In this manual, the following symbols are used:

### **WARNING:**

This symbol indicates a potentially hazardous situation that might result in death or serious injury when you misuse the machine without following the instructions under this symbol. Be sure to read the instructions, all of which are included in "Safety Information", *General Settings Guide*.

### **CAUTION:**

This symbol indicates a potentially hazardous situation that might result in minor or moderate injury or property damage that does not involve personal injury when you misuse the machine without following the instructions under this symbol. Be sure to read the instructions, all of which are included in "Safety Information", *General Settings Guide*.

\* The statements above are notes for your safety.

### **Important**

If this instruction is not followed, paper might be misfed, originals might be damaged, or data might be lost. Be sure to read this.

### **Preparation**

This symbol indicates information or preparations required prior to operating.

### **Note**

This symbol indicates precautions for operation, or actions to take after abnormal operation.

### **Limitation**

This symbol indicates numerical limits, functions that cannot be used together, or conditions under which a particular function cannot be used.

### **Reference**

This symbol indicates a reference.

[   ]

Keys that appear on the machine's display panel.

[   ]

Keys and buttons that appear on the computer's display.

[   ]

Keys built into the machine's control panel.



# 1. Transmission Mode

## Sending at a Specific Time (Send Later)

Using this function, you can instruct the machine to delay transmission of your fax message until a specified later time. This allows you to take advantage of off-peak telephone charges without having to be by the machine at the time.

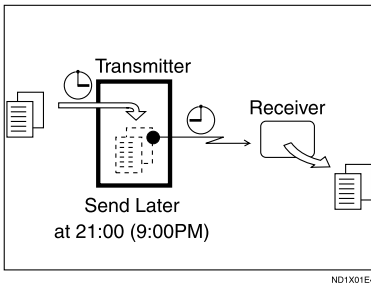

If you have a non-urgent fax, select Send Later with Economy Transmission when you scan it. Faxes will be queued in memory and sent during Economy Transmission Time.

### Important

- ❑ After the machine has been switched off for about one hour, all fax messages stored in memory are lost. If messages are lost for this reason, a Power Failure Report is automatically printed when the operation switch is turned on. Use this report to identify lost messages.

### Limitation

- ❑ This function is unavailable with Immediate Transmission. Use Memory Transmission.

### Note

- ❑ You can specify a time within 24 hours.
- ❑ If the current time shown is not correct, change it. See "Timer Setting", *General Settings Guide*.
- ❑ If the document is sent before the specified time, the Communication Result Report is printed and the job is completed.
- ❑ For convenience, you can program the time when your phone charges become cheaper as the Economy Transmission Time. See p.146 "Program Economy Time".
- ❑ You can program one of the Quick Operation keys with operations for this function. Using the quick operation key allows you to omit step 2. See p.144 "General Settings/Adjustment".

- 1 Place the original, and then select the scan settings you require.

### Reference

p.13 "Placing Originals", *Facsimile Reference <Basic Features>*

p.30 "Scan Settings", *Facsimile Reference <Basic Features>*

- 2 Press [Transmission Mode].

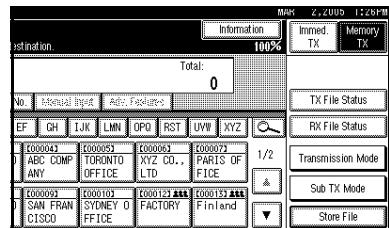

**3** Press **[Send Later]**.

**4** Enter the time (12 hour format) using the number keys, and then select **[AM]** or **[PM]**. Then, press **[OK]**.

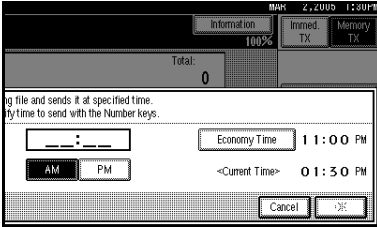

The specified time is shown above the highlighted **[Send Later]**.

**Note**

- Press **[Economy Time]** to specify the economy time.
- When entering numbers smaller than 10, add a zero at the beginning.
- If you make a mistake, press **[Clear]** or the **[Clear/Stop]** key before pressing **[OK]**, and then try again.
- To cancel Send Later, press **[Cancel]**. The display returns to that of step **3**.

**5** Press **[OK]**.

The standby display appears.

**Note**

- To check the settings, press **[Transmission Mode]**.

**6** Specify a destination, and then press the **[Start]** key.

**Note**

- You can cancel the transmission setup for Send Later. See p.19 "Canceling a Transmission".

# Sender Settings

This function tells receivers the fax sender's identity.

If the sender's e-mail address is registered in the destination list, the sender can receive an Immediate TX Result Report by e-mail.

Also, if you enable the Stamp Sender Name, the registered sender's name (user name) appears on the receiver's sheet, lists, or report.

## Preparation

Before using this function, you must register senders in the destination list and specify Use Name as **[Sender]**. See "Fax Destination", *General Settings Guide*.

## Note

- ❑ When user authentication is set, the user logged in is set as sender. An Immediate TX Result Report is sent to the logged-in user's e-mail address.
- ❑ You can program one of the Quick Operation keys with operations for Sender Settings. Quick Operation keys allow you to omit step 2. See p.144 "General Settings/Adjustment".
- ❑ You can use communication management report, etc. to check usage status by specified user. When user authentication is set, you can check usage by logged-in users. See p.162 "Printing Journal". When User ID is set to sender, you can count the number of times of uses by each user. See "Authentication Information", *General Settings Guide*.

## 1 Place the original, and then select the necessary settings.

## Reference

p.13 "Placing Originals", *Facsimile Reference <Basic Features>*

p.30 "Scan Settings", *Facsimile Reference <Basic Features>*

## 2 Press [Transmission Mode].

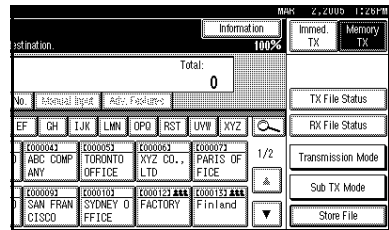

## 3 Press [Sender Settings].

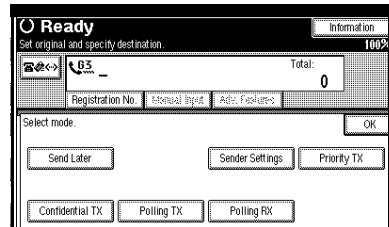

## 4 Select a sender.

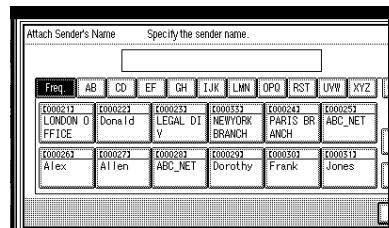

## Note

- ❑ When a protection code for destination is set, the following screen appears. Enter the protection code for destination using the number keys, and then press **[OK]**.

**5** Confirm the selected sender, and then press [OK].

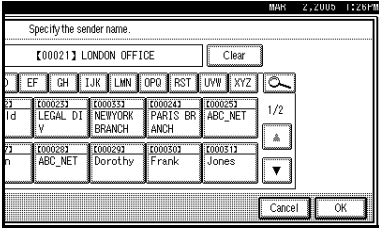

**6** Select [On] or [Off] for the Stamp Sender Name.

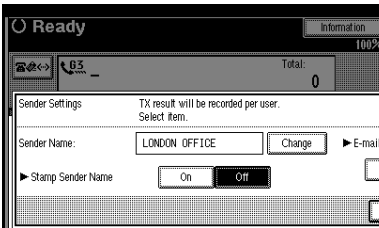

**Printing on the Receiver's Sheet**

If you enable this function, the sender's name (user name) appears on the receiver's sheet, lists, and report.

**1** Select [On] for the Stamp Sender Name function.

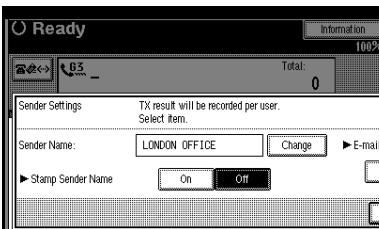

**When an E-mail address is Registered**

If the sender's e-mail address is registered you can specify whether or not to send the transmission result by e-mail to the sender. If you enable this function, sent to the registered mail address.

**Note**

When a user logs in with User ID, the Immediate TX Result Report is sent by e-mail to the logged-in user.

**1** Select [Yes] or [No] for the E-mail TX Results function.

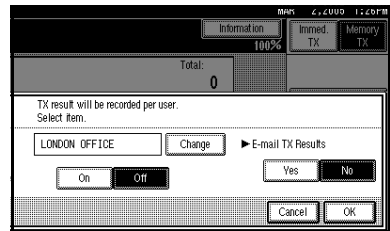

**7** Press [OK].

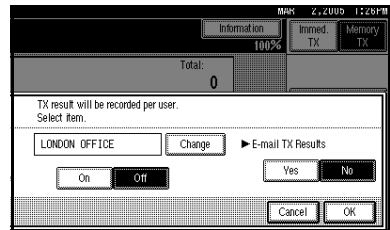

The display returns to that of Step 3.

**Note**

The selected sender's name appears above [Sender Settings]. The sender name is displayed in up to 14 characters, followed by an ellipsis (. . .).



**8** Press [OK].

The standby display appears.

 **Note**

- To check the settings, press [Transmission Mode].

**9** Specify the destination, and then press the [Start] key. **Note**

- To cancel the Sender Settings, cancel the transmission. See p.19 “Canceling a Transmission”.

# Priority Transmission

Documents you send with Memory Transmission are sent in the order they are scanned. Therefore, if several messages are queued in memory, the next document will not be sent immediately. However, by using this function you can have your message sent before other queued messages.

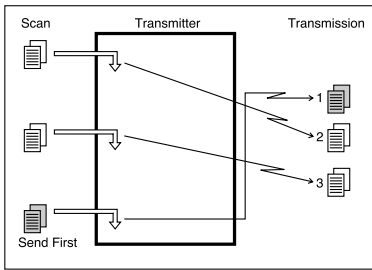

## Limitation

- ❑ This function is not available with Immediate Transmission. If this function is selected, the machine automatically switches to Memory Transmission.

## Note

- ❑ If there is already a message stored with this function or a transmission in progress, your message will be sent after that message has been transmitted.

- 1 Place the original, and then select the scan settings you require.

## Reference

p.13 "Placing Originals", *Facsimile Reference* <Basic Features>

p.30 "Scan Settings", *Facsimile Reference* <Basic Features>

- 2 Press [Transmission Mode].

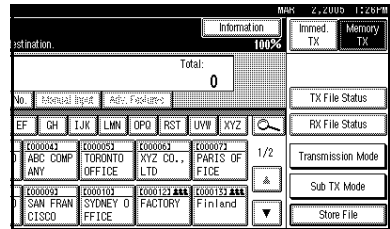

- 3 Press [Priority TX], and then press [OK].

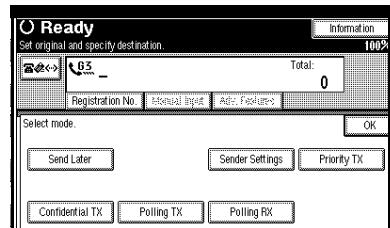

The standby display appears.

## Note

- ❑ To check the settings, press [Transmission Mode].

- 4 Specify the destination, and then press the [Start] key.

## Note

- ❑ Press [Change / Stop TX File] to cancel the transmission. See p.19 "Canceling a Transmission".

# Confidential Transmission

If you want to limit who views your message, use this function. The message will be stored in memory at the other end and not printed until an ID is entered.

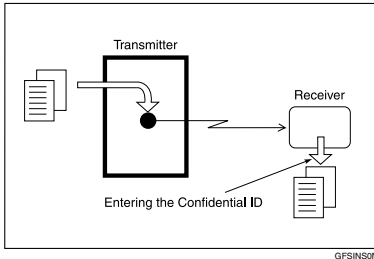

There are two types of Confidential Transmission:

## ❖ Default ID

It is not necessary to enter an ID when transmitting. The other party can print the message by entering the Confidential ID programmed in their machine.

## ❖ ID Override:

Should you want to send a confidential message to a particular person at the other end, you can specify the Confidential ID that the receiver has to enter to see that message. Before you send the message, do not forget to tell the receiver the ID that must be entered to print the message.

## ⚠ Limitation

- ❑ The destination machine must be of the same manufacturer and have the Confidential Reception function.
- ❑ The destination machine must have enough memory available.
- ❑ This function is not available with Internet Fax.

## 📌 Note

- ❑ We recommend you program the Confidential ID in this machine beforehand. See p.191 “Programming a Confidential ID”.
- ❑ An ID can be any 4-digit number (except 0000).
- ❑ If the destination machine is not of the same manufacturer, you can use Confidential Transmission with “SUB Code”. See p.49 “SUB Code”.

- 1** Place the original, and then select the scan settings you require.

## 🔍 Reference

p.13 “Placing Originals”, *Facsimile Reference* <Basic Features>

p.30 “Scan Settings”, *Facsimile Reference* <Basic Features>

- 2** Press [Transmission Mode].

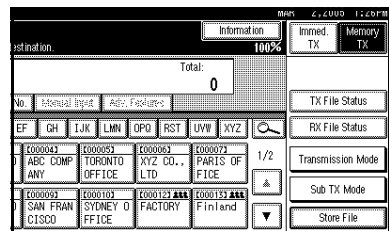

- 3** Press [Confidential TX].

**4** Depending on the Confidential Transmission type, use one of the following procedures:

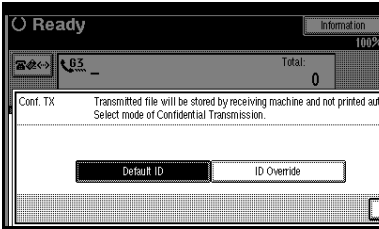

Default ID

- 1 Check that [Default ID] has been selected, and then press [OK].

**Note**

- To cancel Confidential Transmission, press [Cancel]. The display returns to that of step 3.

Override ID

- 1 Select [ID Override: ].
- 2 Enter the Confidential ID (4-digit number) using the number keys, and then press [OK].

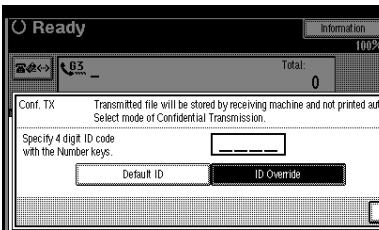

“ID Override:” and the entered Confidential ID are shown above the highlighted [Confidential TX].

**Note**

- If you make a mistake, press [Clear] or the [Clear/Stop] key before pressing [OK], and then try again.
- To cancel Confidential Transmission, press [Cancel]. The display returns to that of step 3.

**5** Press [OK].

The standby display appears.

**Note**

- To check the settings, press [Transmission Mode].

**6** Dial, and then press the [Start] key.

**Note**

- You can cancel the transmission setup for Confidential Transmission. See p.19 “Canceling a Transmission”.

# Polling Transmission

Use Polling Transmission when you want to leave an original in the machine memory for others to pick up. The message will be sent when the other party calls you up.

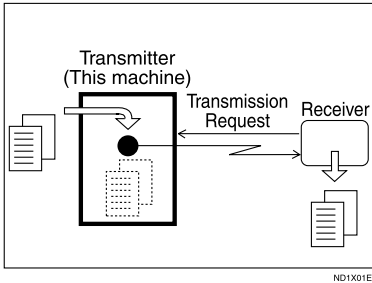

## Preparation

Before using ID Polling Transmission, you must register a polling ID. See p.192 “Programming a Polling ID”.

There are three types of Polling Transmission.

### ◆ Free Polling Transmission

It is not necessary to enter the Polling ID during the procedure. Anybody can poll the message from your machine.

### ◆ Default ID Transmission

It is not necessary to enter the Polling ID during the procedure. The message will only be sent if the Polling ID of the machine trying to poll your message is the same as the Polling ID stored in your machine. Make sure in advance that both machines' Polling IDs are identical.

Before using Default ID Transmission, you need to program the Polling ID. See p.192 “Programming a Polling ID”.

### ◆ ID Override Transmission

You must enter an Override Polling ID unique to the transmission. This ID overrides the ID stored in the machine. The user must supply this ID when they poll your machine. If the IDs match, the message is sent. Make sure in advance the other end knows the ID you are using.

### ● Limitation

- Polling Transmission is allowed only if the receiver's machine has the Polling Reception function.
- Usually, only machines of the same manufacturer that support Polling Reception can perform ID Polling Transmission. However, when the Information Box File function is used, and the other party's fax machine supports Polling Transmission and the SEP function, you can still carry out Polling Transmission with an ID. See p.42 “Information Boxes”.
- This function is not available with Internet Fax.

### Note

- Free Polling and Default ID Transmission allow only one file to be stored in memory.
- ID Override Polling Transmission allows a file to be stored in memory for each ID; you can store up to 400 files by changing IDs.
- When setting using default values, you can set whether a Polling Transmission file is deleted in User Parameters. See p.166 “User Parameters” (switch 11, bit 7). To save a file for frequent sending, set to “Standby (Save)”.

1

- ❑ Polling Transmission Clear Report allows you to verify Polling Transmission has taken place. See p.13 “Polling Transmission Clear Report”. If E-mail TX Results is programmed in a Quick Operation key, you can select whether a report e-mail is sent after transmission. The destination of this report can be selected from the e-mail addresses in the destination list.
- ❑ You can program one of the Quick Operation keys with operations for this function. Using this key allows you to omit step 2. See p.144 “General Settings/Adjustment”.
- ❑ The communication fee is charged to the receiver.

**1** Place the original, and then select the scan settings you require.

**Reference**

- p.13 “Placing Originals”, *Facsimile Reference* <Basic Features>
- p.30 “Scan Settings”, *Facsimile Reference* <Basic Features>

**2** Press [Transmission Mode].

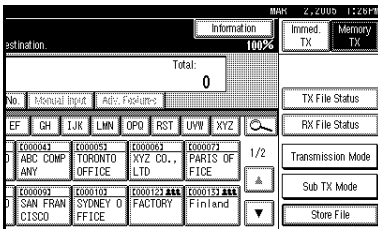

**3** Press [Polling TX].

**4** Depending on the Polling Transmission mode, use one of the following procedures:

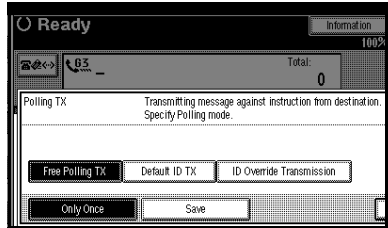

**Free Polling Transmission**

**1** Check that [Free Polling TX] is selected.

**Default ID Transmission**

**1** Select [Default ID TX].

**ID Override Transmission**

- 1** Select [ID Override Transmission].
- 2** Specify a 4-digit ID using the number keys and [A], [B], [C], [D], [E], and [F].

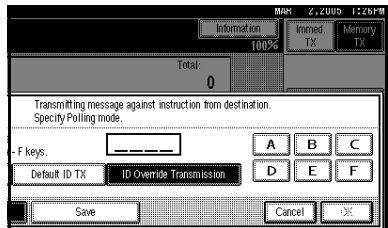

**Note**

- ❑ A Polling ID may be any four numbers (0 to 9) and characters (A to F), except 0000 and FFFF.
- ❑ If you make a mistake, press [Clear] or the [Clear/Stop] key, and then try again.

**5** Press [**Only Once**] or [**Save**] to delete or save the file after transmission.

 **Note**

- To delete the original immediately after transmission, select [**Only Once**].
- To repeatedly send the original, select [**Save**].
- To cancel Polling Transmission, press [**Cancel**]. The display returns to that of step **8**.

**6** Press [**OK**].

“\* \* \* \* \*” appears.

The type of Polling Transmission is shown above the highlighted [**Polling TX**].

**7** Press [**OK**].

 **Note**

- To check the settings, press [**Transmission Mode**].

**8** Press the [**Start**] key.

 **Note**

- You can cancel the transmission setup for Polling Transmission. See p.19 “Canceling a Transmission”.

## Polling Transmission Clear Report

This report allows you to verify Polling Transmission has taken place.

If E-mail TX Results is programmed in a Quick Operation key, you can have the report e-mail sent after transmission. See p.146 “Quick Operation Key”.

 **Limitation**

- This report is not printed if the User Parameters are set to allow the stored originals to be repeatedly sent (Save). See p.166 “User Parameters” (switch 11, bit 7).

 **Note**

- You can turn this function on or off with the User Parameters. See p.166 “User Parameters” (switch 03, bit 6).
- You can have a portion of the sent image printed on the report with the User Parameters. See p.166 “User Parameters” (switch 04, bit 7).
- You can check the result of Polling Transmission with the Journal. See p.27 “Printing the Journal”
- To view the report without text disruption, select a font of even character width in your e-mail application's settings.
- You can display a destination with the User Parameters. See p.166 “User Parameters” (switch 04, bit 4).
- You can indicate the receiving party's information with the User Parameters. See p.166 “User Parameters” (switch 04, bit 5).

# Polling Reception

Use this function to poll a message from another terminal. You can also poll documents from many terminals with only one operation (use Groups and Keystroke Programs to fully exploit this function).

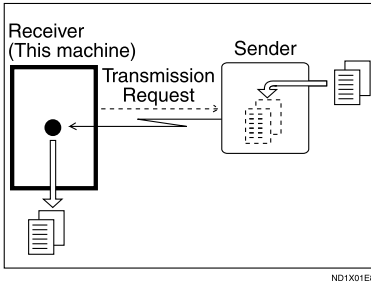

## Preparation

Before using ID Polling Transmission, you must register a polling ID. See p.192 "Programming a Polling ID".

There are two types of Polling Reception.

### ◆ Default ID/Free Polling Reception

Use this method for Free Polling or Default ID Polling. If the Polling ID is programmed in your machine, any messages waiting in the transmitting machine with the same ID are received. If the other machine does not have any messages waiting with the same Polling ID, any messages that do not require ID are received (Free Polling).

### ◆ ID Override Polling Reception

You must enter an Override Polling ID unique to this transmission. This ID overrides the one stored in this machine.

Your machine will receive any messages waiting in the transmitting machine that have matching ID's. If no ID's match, any messages that do not require IDs are received (Free Polling).

### ! Limitation

- Polling Reception requires that the other machine is capable of Polling Transmission.
- Usually, you can only receive documents with a Polling ID from machines of the same manufacturer that support the polling function. However, if the other party's fax machine supports Polling Transmissions and the SEP function, and also has stored IDs, you can still perform Polling Reception. See p.50 "SEP Code".
- This function is not available with Internet Fax.

### ✎ Note

- To receive a message sent by Default ID Polling Transmission or ID Override Polling Transmission, it is necessary to specify the same Polling ID as the sender's. Free Polling Transmission does not require the same Polling ID.



- ❑ Polling Result Report allows you to verify Polling Reception has taken place. See p.16 “Polling Result Report”. If E-mail TX Results is programmed in a Quick Operation key, you can select whether a report e-mail is sent after reception. The destination of this report can be selected from the e-mail addresses in the destination list.
- ❑ You can program one of the Quick Operation keys with operations for this function. Using the key allows you to omit step 1. See p.144 “General Settings/Adjustment”.

### 1 Press [Transmission Mode].

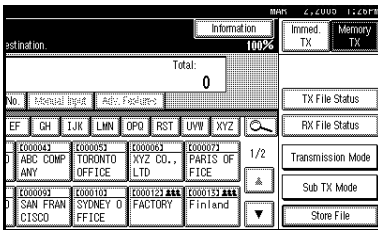

### 2 Press [Polling RX].

- ### 3 Depending on which method you are using, select one of the following procedures:

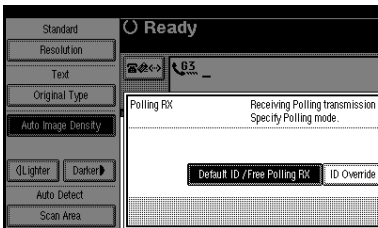

### Default ID/Free Polling Reception

- 1 Check that [Default ID / Free Polling RX] is selected, and then press [OK].

### Note

- ❑ To cancel Polling Reception, press [Cancel]. The display returns to that of step 2.

### ID Override Polling Reception

- 1 Select [ID Override Polling Reception].
- 2 Specify a 4-digit ID using the number keys and [A], [B], [C], [D], [E], and [F], and then press [OK].

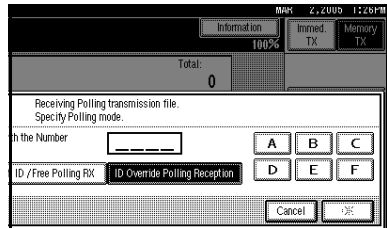

“ID Override: ” and the entered Polling ID are shown above the highlighted [Polling RX].

### Note

- ❑ A Polling ID may be any four numbers (0 to 9) and characters (A to F), except 0000 and FFFF.
- ❑ If you make a mistake, press [Clear] or the [Clear/Stop] key before pressing [OK], and then try again.
- ❑ To cancel Polling Reception, press [Cancel]. The display returns to that of step 2.

### 4 Press [OK].

The standby display appears.

- 5 Dial, and then press the [Start] key.

## Polling Reserve Report

This report is printed after Polling Reception has been set up.

### Note

- You can turn this function on or off with the User Parameters. See p.166 "User Parameters" (switch 03, bit 3).
- You can have a destination displayed with the User Parameters. See p.166 "User Parameters" (switch 04, bit 4).
- You can display a sender name with the User Parameters. See p.166 "User Parameters" (switch 04, bit 5).

- You can display a sender name with the User Parameters. See p.166 "User Parameters" (switch 04, bit 5).

## Polling Result Report

This report is printed after a Polling Reception has been completed and shows its result.

If E-mail TX Results is programmed in a Quick Operation key, you can select whether a report e-mail is sent after reception. See p.146 "Quick Operation Key".

### Note

- You can also check the result of a Polling Reception with the Journal. See p.27 "Printing the Journal".
- You can turn this function on or off with the User Parameters. See p.166 "User Parameters" (switch 03, bit 4).
- To view the report without text disruption, select a font of even character width in your e-mail application's settings.
- You can display a destination with the User Parameters. See p.166 "User Parameters" (switch 04, bit 4).

## 2. Checking and Canceling Transmission Files

After you have pressed the **[Start]** key (after scanning originals), you can check and edit the destination or settings of Memory Transmission. You can also cancel a transmission, change the settings of a transmission, print a stored file, print a list of stored files, and resend a file which the machine failed to transmit.

- Memory Transmission
- Internet Fax Transmission
- Send Later
- Sender Settings
- Priority Transmission
- Confidential Transmission
- Polling Reception
- Polling Transmission
- Transfer Request

### **Note**

- If there are no files being sent, or stored by Memory Transmission, **[Change / Stop TX File]** does not appear on the display.
- You cannot check or edit a file being sent. Also a Confidential Transmission file or stored file to be printed as a report cannot be checked or edited.
- There are cases when a destination may not be selected as the destination appears as “\*”, depending on the security settings.

# Displaying Confirmation of Transmission

**1** Press [Change / Stop TX File].

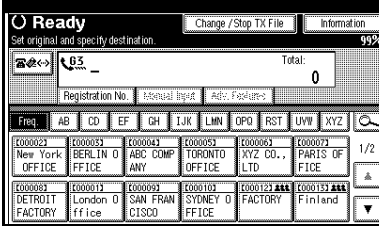

**2** Press [Check / Change Settings].

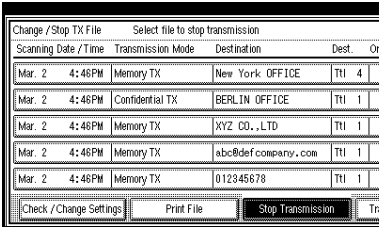

**3** Select a file to check.

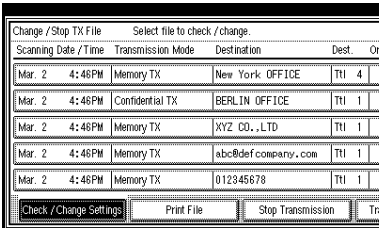

**Note**

- If multiple destinations were specified, only the destination selected first appears.
- If multiple destinations were specified, only the number of unsent messages appears.

**4** Confirm a transmission, and then press [Exit].

**5** Press [Exit].

The standby display appears.

# Canceling a Transmission

You can cancel transmission of a file when the file is being sent, stored in memory, or fails to transmit. All the scanned data is deleted from memory.

You can cancel a file for Memory Transmission. This function is useful to cancel a transmission when you notice a mistake in destination or with the originals after storing. To cancel Memory Transmission, search for the file to be canceled among the files stored in memory, and then delete it.

## Note

- If you cancel a transmission while the file is being sent, some pages of your file may have already been sent and will be received at the other end.
- If the transmission finishes while you are carrying out this procedure, transmission cannot be canceled.

## 1 Press [Change / Stop TX File].

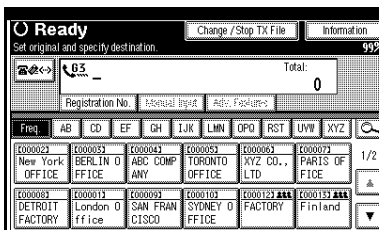

## 2 Select a file whose transmission you want to cancel.

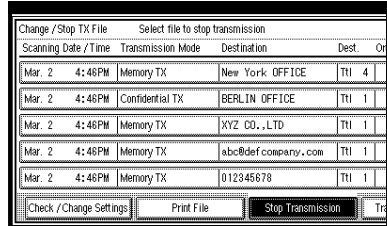

## Note

- To display only the files being sent, press [**Files under TX**].
- If multiple destinations were specified, only the number of unsent messages appears.
- If multiple destinations were specified, only one destination number appears. To display all destinations, press [**Check / Change Settings**].

## 3 Press [Stop Transmission].

The selected file is deleted.

## Note

- To quit transmission cancel, press [**Save**].
- To cancel another transmission, repeat from step 2.

## 4 Press [Exit].

The standby display appears.

# Deleting a Destination

You can delete destinations.

**Note**

- If you delete a destination that is the only destination for a transmission, the transmission is canceled.

**1** Press [Change / Stop TX File].

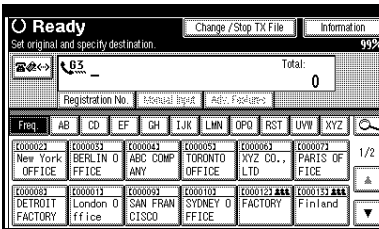

**2** Press [Check / Change Settings].

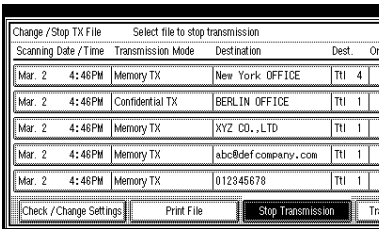

**3** Select the file from which you want to delete a destination.

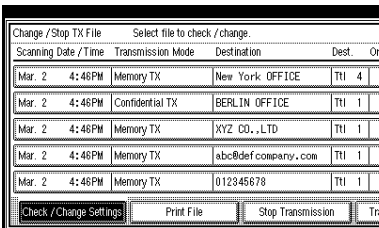

**4** Press [Change] for the destination you want to delete.

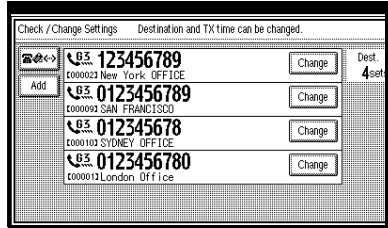

**Note**

- Press [Left Arrow] to switch the destination between fax number, Internet Fax address and IP-Fax address.

**5** Press [Clear] to delete the destination.

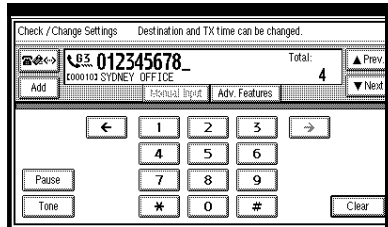

**Note**

- Pressing [Clear] deletes by single digits the fax number or IP-Fax address entered using the number keys. The destination specified using destination keys or Internet Fax address can be entirely deleted at once by pressing [Clear].

**6** Press [Exit].

**Note**

- To delete another destination, repeat from step 3.

**7** Press [Exit].

The standby display appears.

# Adding a Destination

## Note

- A destination cannot be added using a destination list.

### 1 Press [Change / Stop TX File].

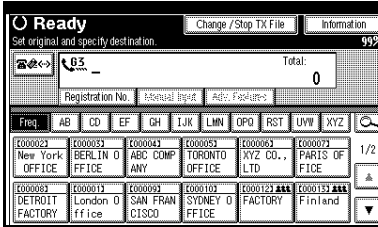

### 2 Press [Check / Change Settings].

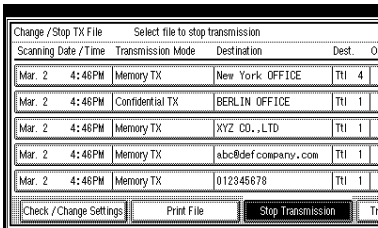

### 3 Select the file to which you want to add a destination.

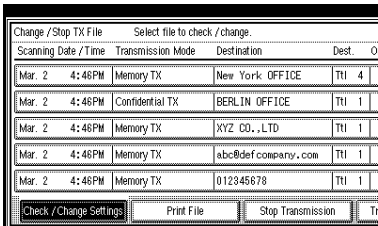

### 4 Press [Add].

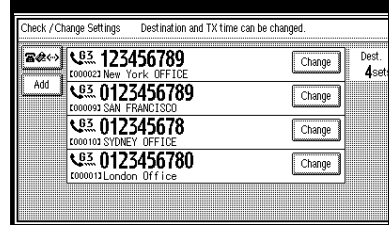

## Note

- Press [Add] to switch the destination between fax number, Internet Fax address and IP-Fax address.

### 5 Specify the destination using the number keys or soft (on-screen) keys.

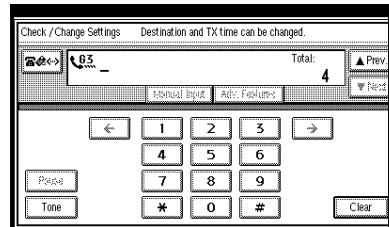

## Note

- To add e-mail address, press [Manual Input], and then specify the destination.
- You can also program a SUB Code or SEP Code by pressing [Adv. Features].

### 6 Press [Exit].

## Note

- Repeat steps 3, if you want to add another destination.

### 7 Press [Exit].

The standby display appears.

2

# Changing the Transmission Time

You can change the transmission time specified with Send Later. See p.3 “Sending at a Specific Time (Send Later)”.

You can also delete the transmission time. If the transmission time is deleted, the file is transmitted immediately.

**1** Press **[Change / Stop TX File]**.

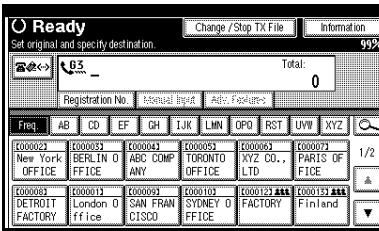

**2** Press **[Check / Change Settings]**.

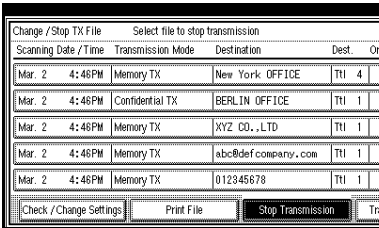

**3** Select the file for which you want to change or cancel the transmission time.

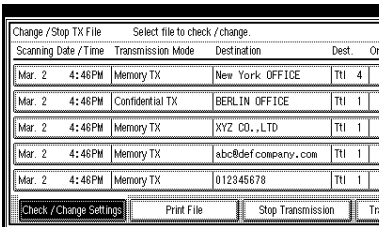

**4** The recipient appears.

**5** Press **[Change TX Time]**.

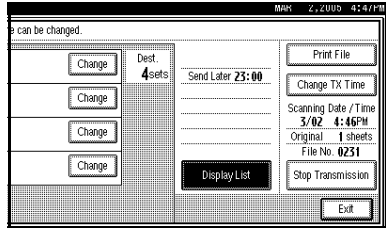

**6** Press **[Clear]**, and then re-enter the transmission time using the number keys or select **[Economy Time]**, and then press **[OK]**.

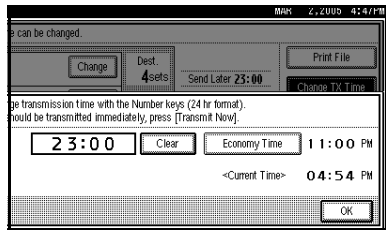

**Note**

- If you select **[Economy Time]**, the economy time already specified is entered. See p.144 “General Settings/Adjustment”.
- If you press **[Transmit Now]**, the file is transmitted immediately. However, if there is a file on standby, that file is sent first.

**7** Press **[Exit]**.

**Note**

- Repeat from step **3**, if you want to change another transmission time.

**8** Press **[Exit]**.

The standby display appears.



# Printing a File

If you want to check the contents of a file that is stored in memory and not yet sent, use this procedure to print it out.

**Note**

- Confidential Transmission files are displayed, but cannot be printed.
- You can also print files that have not been successfully transmitted.

**1** Press [Change / Stop TX File].

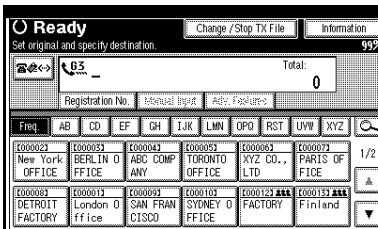

**2** Press [Print File].

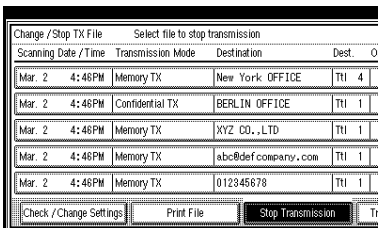

**3** Select the file you want to print.

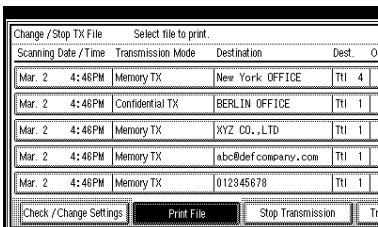

**Note**

- If multiple destinations were specified, only the number of unsent messages appears.
- If you want two-sided printing, press [Print 2 Sided].
- To cancel printing, press [Cancel]. The display returns to that of step 3.

**4** Press the [Start] key.

**Note**

- To cancel printing after pressing the [Start] key, press [Stop Printing]. The display returns to that of step 3.

**5** Press [Exit].

The standby display appears.

**Note**

- Repeat from step 3, if you want to print another file.

# Resending a File

Machine memory stores messages that could not be successfully transmitted using Memory Transmission. Use this procedure to resend these messages.

2

## Preparation

You should select "Store for 24 hours" for "Store a message that could not be transmitted" in User Parameters. See p.166 "User Parameters" (switch 24, bit 0).

## Note

- Files that could not be transmitted will be kept for either 24 or 72 hours depending on how you program this function. See p.166 "User Parameters" (switch 24, bit 1).

## 1 Press [Change / Stop TX File].

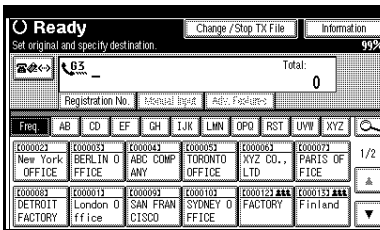

## 2 Press [Transmit Failed File].

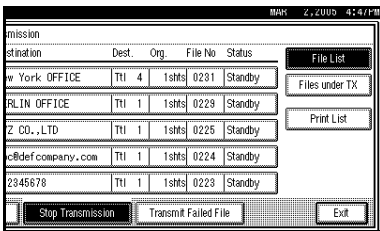

## 3 Select the file you want to resend.

"TX failed" is displayed for files that could not be sent.

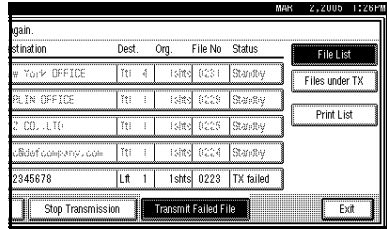

## Note

- If multiple destinations were specified, only the destination number appears.
- If multiple destinations were specified, only the number of unsent messages appears.
- To add a destination, press [Add], and then specify the destination.

## 4 Press [OK].

## Note

- To cancel transmissions, press [Cancel]. The display returns to that of step 3.
- Repeat from step 3 to resend another file.

## 5 Press [Exit].

The standby display appears. Transmission starts.

# Printing a List of Files in Memory (Print TX File List)

Print this list if you want to find out which files are stored in memory and what their file numbers are. Knowing the file number can be useful (for example when erasing files).

**Note**

- The contents of a file stored in memory can also be printed. See p.23 "Printing a File".
- You can display a sender name with the User Parameters. See p.166 "User Parameters" (switch 04, bit 5).

**1** Press [Change / Stop TX File].

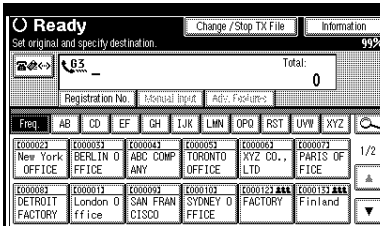

**2** Press [Print List].

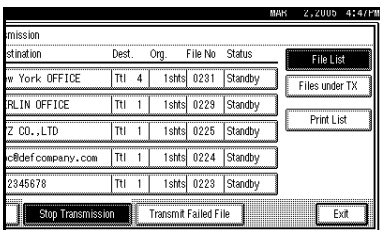

**Note**

- To cancel printing before pressing the [Start] key, press [Cancel]. The display returns to that of step 2.

**3** Press the [Start] key.

**Note**

- To cancel printing after pressing the [Start] key, press [Stop Printing]. The display returns to that of step 2.

**4** Press [Exit].

The standby display appears.



# 3. Communication Information

## Printing the Journal

The Journal contains information about the last 50 communications (maximum) made by your machine. It is printed automatically after every 50 communications (receptions & transmissions).

You can also print a copy of the Journal at any time by following the procedure below.

If the machine is installed with the optional extra G3 interface unit, you can print the Journal of each line type.

### Important

The contents of a Journal printed automatically are deleted after printing. Keep the journal if you require a record of transmissions and receptions. You can check a total of 200 communications (receptions & transmissions) on the display.

### ◆ All

Prints the results of communications in the order made.

### ◆ Print per File No.

Prints only the results of communications specified by file number.

### ◆ Print per User

Prints the results of communications by individual sender.

### Note

The setting on the machine can be changed so that user codes will be printed instead of user names. For more information, contact your service representative.

- The sender name column of the Journal is useful when you need to program a special sender. See p.171 “Special Senders to Treat Differently”.
- You can set whether the Journal is automatically printed after every 50 communications in User Parameters. See p.166 “User Parameters” (switch 03, bit 7).
- You can display a sender name with the User Parameters. See p.166 “User Parameters” (switch 04, bit 5).
- You can set whether you print the Journal by line type. See p.166 “User Parameters” (switch 19, bit 1).
- You can program one of the Quick Operation keys with operations for this function. Using the key allows you to omit steps 1. See p.144 “General Settings/Adjustment”.
- Depending on security settings, the destination may not appear.

### 1 Press [Information].

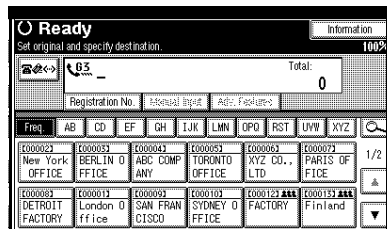

### 2 Press [Print Journal].

### 3 Select a printing mode.

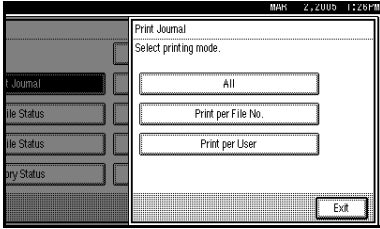

All

1 Select [All].

Print per File No.

- 1 Select [Print per File No.].
- 2 Enter a 4-digit file number.

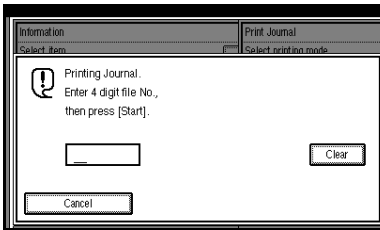

- Note**
- If you make a mistake, press [Clear] or the [Clear/Stop] key, and then try again.

Printing per User

- 1 Select [Print per User].
- 2 Select a user.

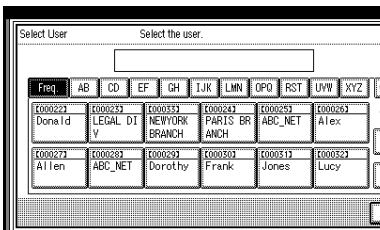

- Note**
- Press [Cancel] if the user is not registered. The display returns to that of step 2.

3 Press [OK] after checking the user name shown on the display.

- Note**
- Press [Clear] to return to the previous screen if a wrong user name is selected.

4 Press the [Start] key.

- Note**
- To cancel a file printing, press [Stop Printing]. The display returns to that of step 2.

5 Press [Exit] twice. The standby display appears.

# Journal

\*\*\* Journal (Mar. 1 2005 6:38PM) \*\*\*

P. 1

1) ABC.COMPANY  
 2) DESIGN  
 (Manual print)

<TX>							
Date	Time	Destination	Mode	TXtime	Page	Result	File No.
Mar. 1	2:35PM	NEW YORK OFFICE	G3TESM	0'31"	P.1	OK	0528
	2:36PM	LONDON OFFICE	G3TESM	0'07"	P.2	OK	0529
	2:40PM	PARIS OFFICE	G3TESM	0'01"	P.1	OK	0530
	6:27PM	--LAN-Fax-->	*DM	0'02"	P.1	---	DESIGN 0536
	6:28PM	NEW YORK OFFICE	G3TEDM	0'53"	P.1	---	DESIGN 0536
	7:25PM	aaa@abc.company.com:3	⊕TS	0'01"	P.1	---	0537

<RX>							
Date	Time	Sender	Mode	RXtime	Page	Result	File No.
Mar. 1	2:45PM	PARIS OFFICE	G3RES	0'04"	P.1	OK	0531
	2:49PM	NEW YORK OFFICE	G3RESC	0'11"	P.2	OK	0532
	2:00PM	LONDON OFFICE	G3RED	0'03"	P.1	OK	0533
	2:30PM	LA FACTORY	G3RES	0'02"	P.1	OK	0534
	2:32PM	BERLIN OFFICE	G3REF	0'03"	P.1	+OK	0535

TX Count    00021 # : Batch M : Memory S : Standard > : Reduction Q : RX Notice Req. Folder	RX Count    00020 C : Confidential L : Send later D : Detail H : Stored/D.Server A : RX Notice
\$ : Transfer @ : Forwarding F : Fine * : LAN-Fax ⊕ : Mail	P : Polling E : ECM U : Super Fine + : Delivery <> : IP-FAX

ADJ1025

## 1. Printing date

Shows the date and time when the report is printed.

## 2. Programmed Fax Header

Shows the sender name programmed for printing.

## 3. Date

Shows the transmission or reception date.

## 4. Time

Shows the transmission or reception start time.

## 5. Other end

### ◆ For fax destinations

- Shows the name (for display) programmed by the other end.
- Shows the programmed fax number if the name (for display) has not been programmed.
- If neither name nor fax number has been programmed by the other end, an entered fax number or a name programmed in a destination list is shown for transmissions.
- The space will be blank for receptions.

### Note

- To prioritize a fax number or name programmed in the destination list, contact your service representative.

### ◆ For Internet Fax destinations

At time of transmission, it shows the e-mail address or name programmed in the destination list. At time of reception, it shows the e-mail address of the sender.

At time of broadcasting transmission, it shows the number of destinations after the e-mail addresses or names of destination.

#### Note

- When documents are transmitted from the computer to the machine, -- LAN-Fax --> appears. To check if the documents are sent to the receiver, confirm the same File No.

### ◆ For IP-Fax destinations

Shows the IP-Fax destination or name programmed in the destination list. The Fax destination details appear on reception report.

### ◆ For Folder destinations

Shows the name programmed in the destination list for transmissions.

## 6. Communication mode

- For fax transmissions and receptions  
After "T" for outgoing fax or "R" for ingoing fax, shows a communication mode. If the optional Extra G3 interface unit has been installed, "G3-1", "G3-2", "G3-3", or "G3 Auto" will be shown.
- For Internet Fax transmissions and receptions  
After , and "T" for outgoing e-mail or "R" for ingoing e-mail, the communication mode appears in alphabetical letters or symbols. Outgoing e-mail set for Reception Notice of E-mail Options bears a "Q", whereas "A" appears with reception confirmation e-mails.

- For IP-Fax transmissions and receptions

After , and "T" for outgoing fax or "R" for ingoing fax, the communication mode appears in alphabetical letters or symbols.

- For Folder receptions  
Shows  (folder mark).

## 7. Communication time

Shows time taken for transmissions or receptions.

## 8. Number of pages

Shows the number of pages transmitted or received.

## 9. Communication result

Shows the result of transmissions or receptions.

OK: All pages were properly transmitted or received. When Reception Notice is activated using the Internet Fax E-mail Options, receipt of Reception Notice is shown.

--: The Internet Fax was document sent to the mail server programmed in this machine. (However, this does not mean the e-mail was delivered.) When using LAN-Fax, communication results from this machine to a computer.

Error: A communication error occurred.

D: Power was disconnected during communication. Not all fax messages were transmitted.

## 10. User name

Shows the sender's name.

## 11. File number

Shows file management numbers.



# Checking the Transmission Result (TX File Status)

You can browse a part of the Immediate TX Result Report on the display.

**Note**

- Only the transmission result of the last 200 communications (receptions & transmissions) are shown.
- You can view sent fax messages and their lists, using a network computer Web Image Monitor. For details, see the Web Image Monitor's Help.
- If a transmission is completed while you are using this function, the result will not appear. To view the latest result, exit TX File Status, and then try again.
- You can program one of the Quick Operation keys with operations for this function. Using the key allows you to omit steps 1. See p.144 "General Settings/Adjustment".

**1** Press [Information].

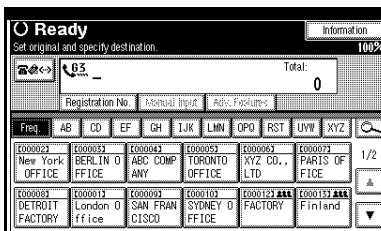

**2** Select [TX File Status].

**3** Check the transmission results.

TX File Status		Displaying transmission file status.		Original C
Date / Time	Destination			
Mar. 2 5:11 PM	London Office			1
Mar. 2 5:09 PM	NEWYORK DIV.			1
Mar. 2 5:09 PM	0312345678			1
Mar. 2 5:09 PM	NEWYORK DIV.			1
Mar. 2 5:09 PM	london@abcdcompany.com			1
Mar. 2 5:09 PM	miller@abcdcompany.com			1

Transmission results are displayed, from the latest result down, in groups of six.

**Note**

- When a fax is sent, "Destination:" shows the Own Fax Number or Fax Header information of a receiver. The e-mail address and name programmed in the destination list appears in the "To" field of the sent Internet Fax document. For a transmission from a computer, "-- LAN-Fax -->" is shown.
- Depending on security settings, the destination may appear as \*.

**4** Press [Exit] twice.

The standby display appears.

**Note**

- When documents are transmitted from the computer to the machine, -- LAN-Fax --> appears. To check if the documents are sent to the receiver, confirm the same File No.

3

# Checking the Reception Result (RX File Status)

You can browse a part of the Reception Result Report on the display.

**Note**

- Only the reception result of the last 200 communications (receptions & transmissions) are shown.
- You can view received fax messages and their lists, using a network computer Web Image Monitor. For details, see the Web Image Monitor's Help.
- If a message is received while you are using this function, the result will not appear. To view the latest result, exit RX File Status, and then try again.
- You can program one of the Quick Operation keys with operations for this function. Using the key allows you to omit steps 1. See p.144 "General Settings/Adjustment".

**1** Press [Information].

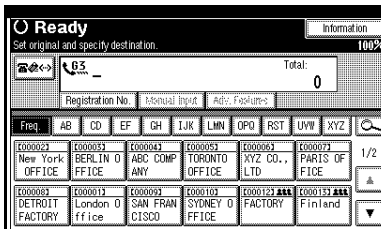

**2** Select [RX File Status].

**3** Check the reception results.

RX File Status		Displaying reception file status.		Original C
Date / Time	TX Station			
Mar. 2 5:11 PM	NEWYORK DIV.			1
Mar. 2 5:09 PM	PARIS DIV.			1
Mar. 2 5:09 PM	NEWYORK DIV.			1
Mar. 2 5:09 PM				1
Mar. 2 5:09 PM	miller@abcdcompany.com			1
Mar. 2 5:09 PM	miller@abcdcompany.com			1

Reception results are displayed from the latest result in groups of six.

**Note**

- When a fax or IP-Fax is received, Transmission Station shows the sender's fax number or Fax Header information. The sender's e-mail address appears in the "From" field of the received Internet Fax.

**4** Press [Exit] twice.

The standby display appears.

# Displaying the Memory Status

Use this function to display a summary of current memory usage. Items shown are the percentage of free memory space, the number of received confidential messages, the number of files to be sent, the number of Memory Lock files and the number of received messages to be printed.

**1** Press [Information].

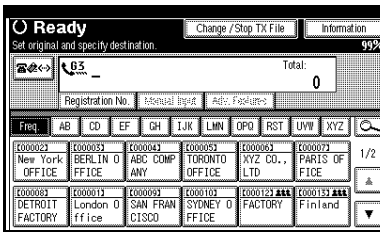

**2** Press [Memory Status].

**3** Check the memory status.

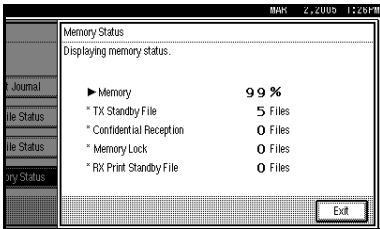

**Note**

☐ “Others” will be displayed:

- When storing attachment files. See p.65 “Sending an Auto Document”.
- For storing Reception Request files. See p.52 “Transfer Station”.
- When storing originals in the Information Boxes. See p.42 “Storing Messages in Information Boxes”.

- When sending to the Personal Box. See p.41 “Printing Personal Box Messages”.

☐ If you have made the machine save received messages on the hard disk, see “RX Print Standby File” on the display to check the number.

**4** Press [Exit] twice.

The standby display appears.

# Printing/Deleting Received and Stored Documents (Print/Delete Stored RX File)

You can print documents that are received and stored on the hard disk. You can also delete unwanted documents.

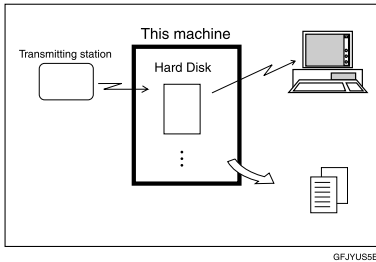

3

## Preparation

Make a setting for received and stored documents before using this function. See p.193 “Storing or Printing Received Documents”.

## Note

- If you have selected to store received documents and specified an e-mail address for notification of receipt, fax reception notification can be sent to that e-mail address. See p.194 “Reception Report e-mail”.
- You can store up to 400 received documents on the hard disk.
- You can view, print received and stored documents using a Web Image Monitor or DeskTopBinder. See p.123 “Viewing Fax Information Using a Web Browser” or the DeskTopBinder’s manuals and Help.

## Printing Received and Stored Documents

Use the following procedure to print documents saved on the hard disk.

### Note

- This function allows you to print only received and stored documents.
- You cannot print and delete received documents using the Document Server function.
- You can specify and print multiple documents. You can specify a maximum of 30 documents at one time.

### 1 Press [Information].

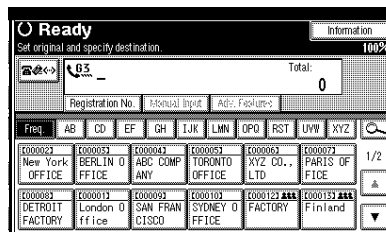

### 2 Press [Print / Delete Stored RX File].

### 3 Select a file to be printed, and then press [Print].

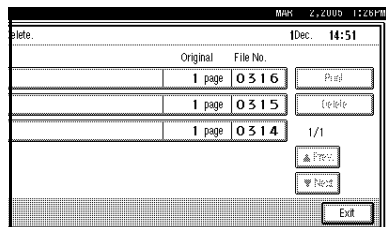

**4** Select the printing mode, and then press the **[Start]** key.

**Note**

- To cancel printing, press **[Cancel]**. The display returns to that of step **3**.
- To delete the document after printing, press **[Delete File after Printing]**.
- To perform two-sided printing, press **[Print on 2 Sides]** before pressing the **[Start]** key.

**5** Press **[Exit]** twice.

The standby display appears.

**3** Select a file to be deleted, and then press **[Delete]**.

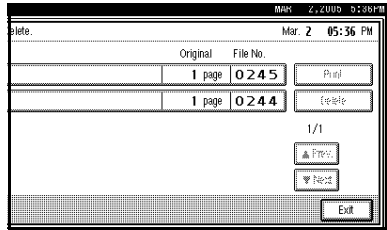

**4** Press **[Yes]**.

**Note**

- To cancel a deletion, press **[No]**. The display returns to that of step **3**.

**5** Press **[Exit]** twice.

The standby display appears.

## Deleting Received and Stored Documents

Use the following procedure to delete documents stored on the hard disk.

**Note**

- You cannot delete a document while another person is previewing or printing it using a Web Image Monitor or DeskTopBinder.
- You can specify and print multiple documents. You can specify a maximum of 30 documents at one time.

**1** Press **[Information]**.

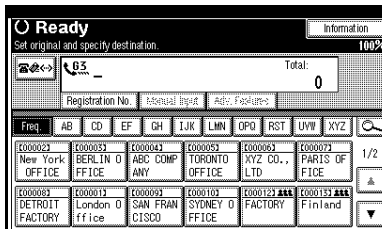

**2** Press **[Print / Delete Stored RX File]**.

3

# Printing a Confidential Message

This function is designed to prevent unauthorized users from reading your messages. If someone sends you a message using Confidential Transmission, it is stored in memory but not automatically printed. To print the message you have to enter the Confidential ID Code. When your machine has received a confidential message, the **Confidential File** (☑) indicator lights.

3

### Preparation

Before using this function, program your Confidential ID. See p.191 "Programming a Confidential ID".

### Important

- ☐ If the main power switch is off more than one hour, all confidential messages are deleted. When this happens, use the Power Failure Report to identify which messages have been deleted. See p.198 "Turning Off the Main Power / When a Power Failure Occurs".

### Limitation

- ☐ You must program the Confidential ID for Confidential Reception to work.
- ☐ This function is not available with Internet Fax.

### Note

- ☐ You can program one of the Quick Operation keys with operations for this function. Using the key allows you to omit steps 2. See p.144 "General Settings/Adjustment".

## 1 Confirm that the Confidential File indicator is lit.

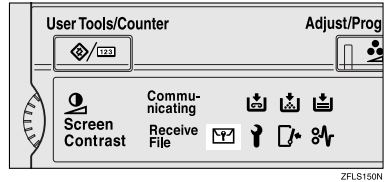

## 2 Press [Information].

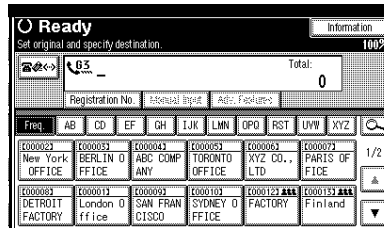

## 3 Press [Print Confidential RX File].

### Note

- ☐ If no confidential messages have been received, the message "No reception file." is shown. Press [Exit].

## 4 Enter a 4-digit Confidential ID using the number keys, and then press the [Start] key.

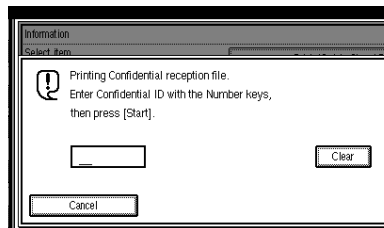

The Confidential ID differs depending on the Sender's specifications.

**Note**

- You must enter the Confidential ID programmed in this machine, if the received file has no Confidential ID.
- You must enter the Confidential ID programmed by the sender. Confirm the sender's Confidential ID in advance.
- If the Confidential IDs or Personal Confidential IDs do not match, the message "No reception file under specified Confidential ID." appears. Press **[Exit]** to cancel the operation, and then check the Confidential ID or Personal Confidential ID with the other party, and then try again.

**5** Press **[Exit]**.

The standby display appears.

 **If you cannot print confidential files even if the Confidential File (CF) indicator is lit.**

The Confidential File indicator also lights if the machine received a message with a SUB Code. Check the Personal Boxes.

**Note**

- Print from the Personal Box, when a file has been sent from another party with a SUB Code attached. See p.41 "Printing Personal Box Messages".

## Confidential File Report

When this function is turned on, this report is printed whenever your machine receives a confidential message.

**Note**

- You can turn this function on or off with the User Parameters. See p.166 "User Parameters" (switch 04, bit 0).
- You can display a destination with the User Parameters. See p.166 "User Parameters" (switch 04, bit 4).

# Printing a File Received with Memory Lock

This is a security function designed to prevent unauthorized users from reading your messages. If Memory Lock is switched on, all received messages are stored in memory and are not automatically printed. To print the messages, you have to enter the Memory Lock ID Code. When your machine has received a message with Memory Lock, the **Confidential File** (🔒) indicator blinks.

### 📄 Preparation

Before using this function, program your Memory Lock ID. See p.192 "Programming a Memory Lock ID".

Before using this function, set Memory Lock to On. See p.174 "Memory Lock".

### 🔴 Important

- ❑ If the main power switch is turned off for more than an hour, all messages protected by Memory Lock will be deleted. In that case, the Power Failure Report will be printed so you can confirm which messages have been deleted. See p.198 "Turning Off the Main Power / When a Power Failure Occurs".

### 📌 Note

- ❑ If Memory Lock and received document storage are both set to on, Memory Lock is unavailable and received documents become stored documents. For details, see p.193 "Storing or Printing Received Documents" and p.34 "Printing/Deleting Received and Stored Documents (Print/Delete Stored RX File)".
- ❑ Even when Memory Lock is available, if free memory is insufficient, reception is not possible.

- ❑ You can also apply a Memory Lock to messages that come only from certain senders. See p.174 "Programming/Changing Special Senders".
- ❑ Messages received by Polling Reception are automatically printed even if this function is switched on.
- ❑ You can program one of the Quick Operation keys with operations for this function. Using the key allows you to omit steps 2. See p.144 "General Settings/Adjustment".

## 1 Confirm that the Confidential File indicator is blinking.

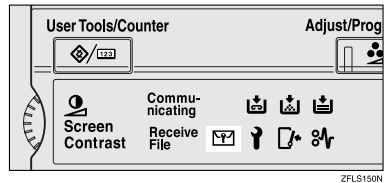

## 2 Press [Information].

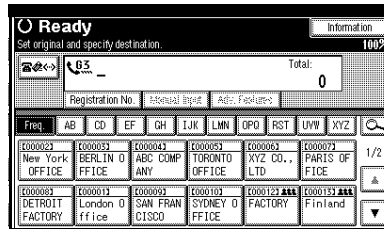

## 3 Press [Print Memory Lock].

### 📌 Note

- ❑ If no messages were received while Memory Lock was switched on, the message "No reception file." is shown. Press [Exit].



- 4 Enter a 4-digit Memory Lock ID with the number keys, and then press the **[Start]** key.

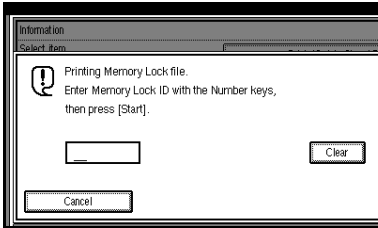

 **Note**

- If the Memory Lock ID does not match, the message "Specified code does not correspond to programmed Memory Lock ID." appears. Press **[Exit]** and retry after checking the Memory Lock ID.

- 5 Press **[Exit]**.

The standby display appears.

# Personal Boxes

## Preparation

Before using this function, set the Personal Box in advance. See p.181 "Programming/changing Personal Boxes".

## Personal Boxes

This function lets you set up the machine so that incoming messages addressed to certain users are stored in memory instead of being printed out immediately.

Each user must be assigned a SUB Code (Personal Code) that has been designated as a Personal Box beforehand. When the other party sends their message, they specify the SUB Code of the receiver. When the message is received, it is stored in the Personal Box with the matching SUB Code. In order to print a received message.

This enables several individuals or departments to share a single fax machine yet be able to differentiate between messages. Furthermore, if you specify a receiver for the Personal Box, instead of being stored in memory, incoming messages with this SUB Code appended are forwarded directly to the destination you specify. You can specify a fax number, e-mail address or IP-Fax destination as the receiver. See p.181 "Programming/changing Personal Boxes" for details on programming receivers.

- To be able to receive messages into a Personal Box you must inform the sender of the SUB Code programmed for that Personal Box and ask them to send the message using SUB Code Transmission with that SUB Code. See p.49 "SUB Code".
- When messages have been received into Personal Boxes, the Confidential Reception/Memory Lock indicator lights and the Confidential File Report is printed. See p.37 "Confidential File Report".
- If a receiver is assigned, the delivered document is deleted.
- If a receiver is not assigned, print these messages. See p.41 "Printing Personal Box Messages".

### ◆ SUB Code and SEP Code

SUB Code and SEP Code are IDs consisting of up to 20 digits, and can include numbers, #, \*, and spaces. To use this function, you must program a box and SUB/SEP Code beforehand. The other party can send messages to, and retrieve stored messages from, this box using the code.

### ✎ Note

- ☐ This function is not available when you have set received documents to be delivered to the network delivery server.

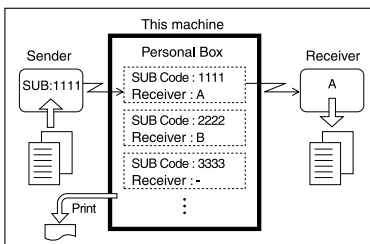

## Printing Personal Box Messages

Follow these steps to print a message that has been received into a Personal Box.

**Note**

- If you print a Personal Box message, it is deleted.

**1** Make sure that the Confidential File indicator is lit.

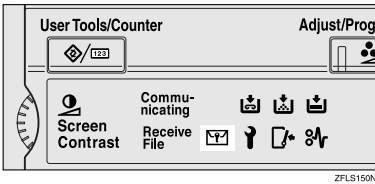

**2** Press [Information].

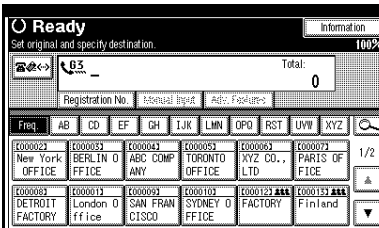

**3** Press [Print Personal Box File].

**4** Select the box with the message you want to print.

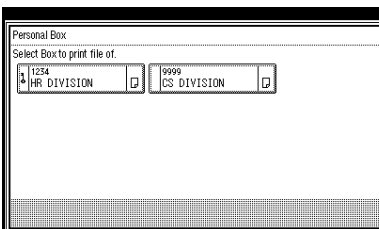

## When a password is required

The display appears, when the selected Personal Box password is set in advance.

**Note**

- The password is programmed in "Administrator Tools". See p.181 "Programming/changing Personal Boxes".

**1** Enter the password, and then press [OK].

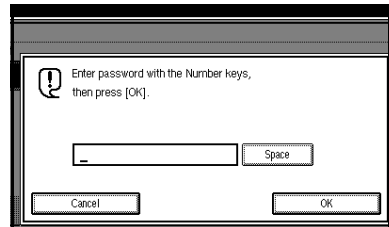

**Note**

- If you make a mistake, press [Clear] or the [Clear/Stop] key before pressing [OK], and then try again.
- To cancel entering a password, press [Cancel]. The display returns to that of step 4.

**5** Press the [Start] key.

**Note**

- To stop printing, press [Stop Printing]. The display returns to that of step 4.

**6** Press [Exit].

**Note**

- To print a message in another Personal Box, refer to step 1, and then try again.

**7** Press [Exit].

The standby display appears.

# Information Boxes

## Preparation

Before using this function, set the Information Box in advance. See p.184 "Programming/changing Information Boxes".

## Information Boxes

Use the Information Box function to set up the machine as Document Server. By scanning documents into Information Boxes, other parties can receive these messages whenever they request them.

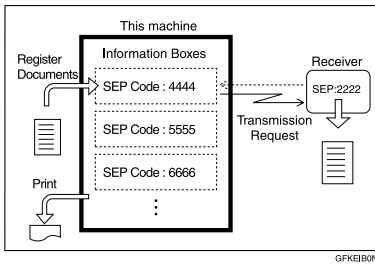

- You can program documents for this function with "Store / Delete / Print Information Box File". See p.42 "Storing Messages in Information Boxes".
- For other parties to be able to retrieve a message programmed in an Information Box, you need to inform them of the SEP Code assigned to that Information Box.
- When an SEP Code Polling Reception request is made by another party, the SEP Code they specify is matched against the SEP Codes programmed in that Information Boxes. If a code matches, the message stored in the Information Box is sent to the other party automatically. See p.50 "SEP Code".

- You can check the contents of Information Boxes with "Store / Delete / Print Information Box File". See p.44 "Printing Information Box Messages".
- You can set a password for Information Boxes in advance. A password can be set in "Administrator Setting". See p.184 "Programming/changing Information Boxes".

## Storing Messages in Information Boxes

Follow these steps to store a message in an Information Box.

### Note

- One Information Box stores one file.
- The stored file is not deleted automatically. If you want to delete a stored file, see p.45 "Deleting Information Box Messages".

### 1 Press [Information].

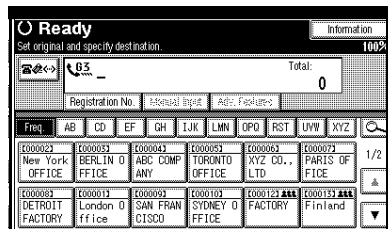

### 2 Press [Store / Delete / Print Information Box File].

- 3** Select the box in which you want to store the file.

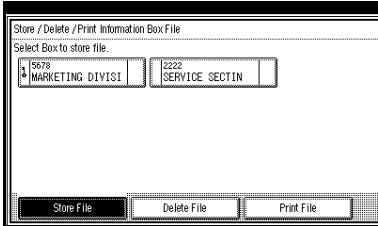

**Note**

- When there are pre-programmed files, a file mark is displayed at the end of the Box Name.
- A message is displayed, when selecting a box with a file stored in it. Press **[Yes]**, when changing the file name. The file stored originally will be overwritten.

When a password is required

- 1** Enter the password, and then press **[OK]**.

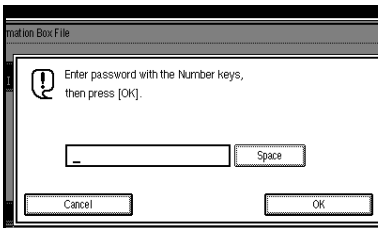

**Note**

- If you make a mistake, press **[Clear]** or the **[Clear/Stop]** key before pressing **[OK]**, and then try again.
- To cancel entering a password, press **[Cancel]**. The display returns to that of step **3**.

- 4** Place the original, and then select the scan settings you require.

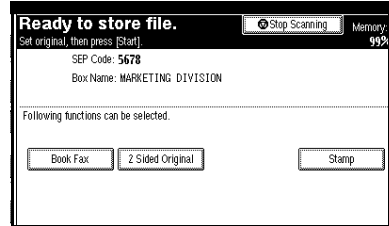

**Note**

- You can also select the following settings:
  - Book Fax
  - 2 Sided Original (The optional ADF is required.)
  - Stamp (The optional ADF is required.)

**Reference**

p.13 "Placing Originals", *Facsimile Reference <Basic Features>*

p.30 "Scan Settings", *Facsimile Reference <Basic Features>*

- 5** Press the **[Start]** key.

The machine starts to scan the original.

To stop scanning, press **[Stop Scanning]**. The display returns to that of step **3**.

- 6** Press **[Exit]**.

**Note**

- To store a message in another Information Box, return to step **3**.

- 7** Press **[Exit]**.

The standby display appears.

## Printing Information Box Messages

Follow these steps to print a message stored in an Information Box.

**1** Press **[Information]**.

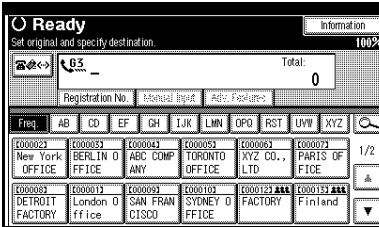

**2** Press **[Store / Delete / Print Information Box File]**.

**3** Press **[Print File]**.

**4** Select the box that contains the stored file you want to print.

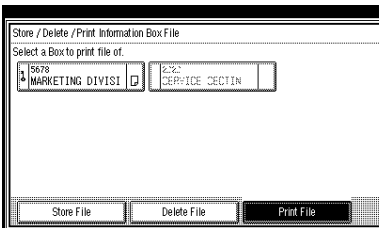

**Note**

- You cannot select a box that has no stored file.

When a password is required

**1** Enter the password, and then press **[OK]**.

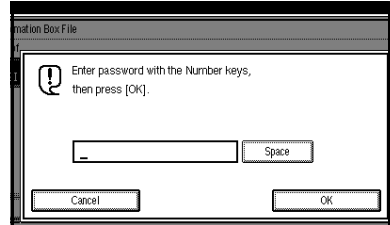

**Note**

- If you make a mistake, press **[Clear]** or the **[Clear/Stop]** key before pressing **[OK]**, and then try again.
- To cancel entering a password, press **[Cancel]**. The display returns to that of step **4**.

**5** Press the **[Start]** key.

**Note**

- If you want two-sided printing, press **[Print 2 Sided]** before pressing the **[Start]** key.
- To stop printing before pressing the **[Start]** key, press **[Cancel]**. The display returns to that of step **4**.
- To stop printing after pressing the **[Start]** key, press **[Stop Printing]**. The display returns to that of step **4**.

**6** Press **[Exit]**.

**Note**

- Repeat from step **4** to print another stored file in the box.

**7** Press **[Exit]**.

The standby display appears.

## Deleting Information Box Messages

Follow these steps to delete a file stored in an Information Box.

**1** Press [Information].

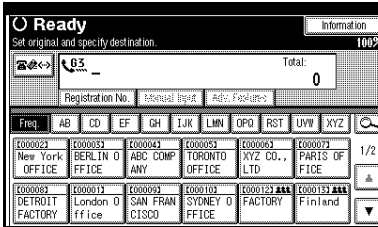

**2** Press [Store / Delete / Print Information Box File].

**3** Press [Delete File].

**4** Select the box that contains the stored file you want to delete.

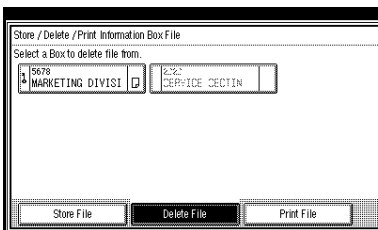

When a password is required

**1** Enter the password, and then press [OK].

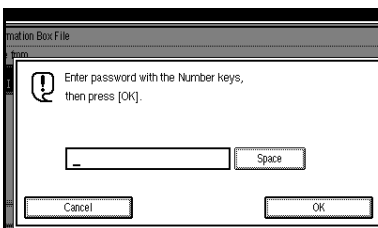

### Note

- If you make a mistake, press [Clear] or the [Clear/Stop] key before pressing [OK], and then try again.
- To cancel entering a password, press [Cancel]. The display returns to that of step 4.

**5** Press [Delete].

### Note

- To stop deleting, press [Do not Delete]. The display returns to that of step 4.

**6** Press [Exit].

### Note

- Repeat from step 4 to delete another stored file in another box.

**7** Press [Exit].

The standby display appears.





# 4. Other Transmission Features

## Handy Dialing Functions

---

### Chain Dial

---

This allows you to compose a telephone number from various parts, some of which may be stored in Quick Dials and some of which may be entered using the number keys.

 **Limitation**

- You cannot use this function with Internet Fax transmission.

 **Note**

- The total number of digits that can be entered is up to 128 using destination keys and number keys.
- For Memory Transmission and Immediate Transmission, insert a pause between parts of a number. For On Hook Dial and Manual Dial, no pause is needed.
- The Advanced Features function programmed in the destination list is unavailable.

---

### (Example) 01133-1-555333

---

Assume that 01133 is stored in a Quick Dial key.

- 1** Place the original, and then select the scan settings you require.
- 2** Press the Quick Dial key that is programmed "01133".
- 3** Press the **[Pause/Redial]** key.
- 4** Enter **[1], [5], [5], [5], [3], [3], [3]** using the number keys.
- 5** Press the **[Start]** key.

---

### Redial

---

The machine stores the last 10 destinations specified in each transmission method. This function saves time when you are sending to the same destination repeatedly, as you do not have to enter the destination again.

 **Limitation**

- The following kinds of destinations are not stored:

- Quick Dials
- Group Dials
- Destinations dialed as Receiving Stations for Transfer Request
- Forwarding terminal of the Substitute Reception
- Destinations dialed using the external telephone
- Destinations dialed by Redial (regarded as already stored in memory)
- Second and later destinations broadcasted to

- To redial a fax number, do not dial any numbers before you press the **[Pause/Redial]** key. If you press the **[Pause/Redial]** key after entering numbers using the number keys, a pause will be entered instead.

 **Note**

- You can specify the Internet Fax destination and IP-Fax using with the Redial function. Select to use this function before pressing **[Manual Input]**.

**1** Place the original, and then select the scan settings you require.

**2** Press the **[Pause/Redial]** key.

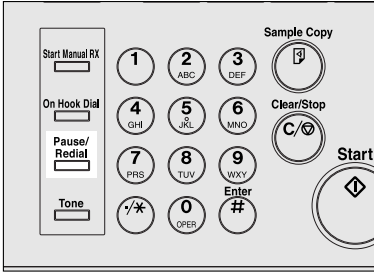

ZFL5090N

**3** Select the destination you want to redial to.

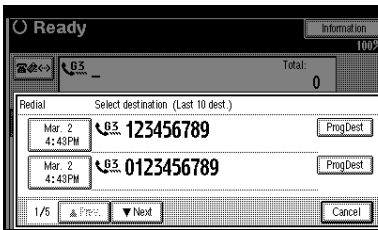

**Note**

- Now that the date and time the original was read appears as a key, select by pressing it.
- When you press **[ProgDest]**, you can register a selected recipient in the destination list. See p.39 “Registering Entered Destinations to the Address Book”, *Facsimile Reference <Basic Features>*.

# Advanced Features

## SUB Code

Normally you can only use Confidential Transmission to send messages to fax machines of the same manufacturer that have the Confidential Reception function. See p.9 “Confidential Transmission”. However, if the other machine supports a similar function called “SUB Code”, you can send fax messages to the other party using this method instead.

### Limitation

- A SUB Code cannot be used with Internet Fax.

### Note

- The ID can be up to 20 digits long.
- You can enter numbers, \*, #, and spaces to program an ID.
- Make sure the number of digits in the ID matches the specification of the machine to which you are sending.
- You can store IDs in destination lists and Programs. See “Fax Destination”, *General Settings Guide*. See p.129 “Registering and Changing Keystroke Programs”.
- Messages you send using this function are marked “SUB” on all reports.
- This function is not available with Internet Fax.

- 1** Place the original, and then select the scan settings you require.

### Reference

p.13 “Placing Originals”, *Facsimile Reference* <Basic Features>

p.30 “Scan Settings”, *Facsimile Reference* <Basic Features>

- 2** Enter the fax number of a destination or an IP-Fax destination.

- 3** Press [Adv. Features].

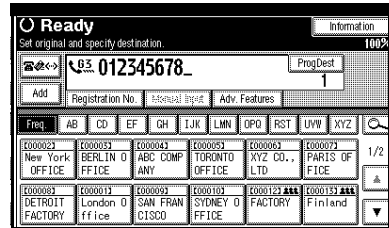

- 4** Press [SUB Code].

- 5** Press [TX SUB Code].

- 6** Enter a SUB Code, and then press [OK].

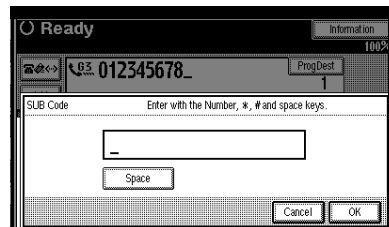

“SUB Code” appears one line above [Adv. Features] on the display.

### Note

- If you make a mistake, press [Cancel] or the [Clear/Stop] key before pressing [OK], and then try again.

- 7** To enter a password, press [Password (SID)].

- 8** Enter the password with the number keys, and then press [OK].

- 9** Press [Exit].

- 10** Press the [Start] key.

**Note**

- If you use Immediate Transmission and the fax machine at the destination does not support the SUB Code function, a message will appear on the display to inform you of this. When this happens, press **[OK]** to cancel the transmission.

**SID Code**

There are times when you may want to use an “SID” (Sender ID) when sending confidential faxes with the SUB Code function.

**Note**

- The ID can be up to 20 digits long.
- You can enter numbers, \*, #, and spaces to program an ID.
- You can store IDs in destination lists and Programs. See p.129 “Registering and Changing Keystroke Programs”. See “Fax Destination”, *General Settings Guide*.
- Messages you send using this function are marked “SID” on all reports.

**SEP Code**

Normally you can only use Polling Reception to receive faxes from machines that have the Polling Reception function and the same manufacturer. However, if a machine of another manufacturer supports Polling Reception, you can receive fax messages from the other party using this method instead.

You can receive messages that have the same SEP Code as the SEP Code you entered.

**Limitation**

- A SEP Code cannot be used with Internet Fax.

**Note**

- The ID can be up to 20 digits long.
- Make sure the number of digits in the ID matches the one set on the machine to which you are sending.
- You can enter numbers, \*, #, and spaces to program an ID.
- You can store IDs in destination lists and Programs. See “Fax Destination”, *General Settings Guide*. See p.129 “Registering and Changing Keystroke Programs”.
- Messages you receive using this function are marked “SEP” on all reports.
- This function is not available with Internet Fax.

**1** Enter the fax number of a destination or an IP-Fax destination.

**2** Press **[Adv. Features]**.

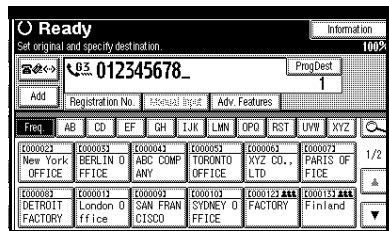

**3** Press **[SEP Code]**.

**4** Press **[RX SEP Code]**.

- 5** Enter a SEP Code, and then press [OK].

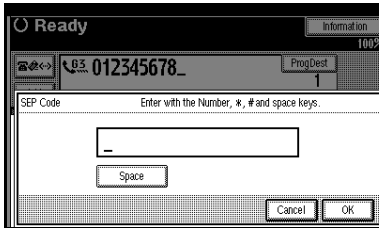

“SEP Code” appears one line above [Adv. Features] on the display.

**Note**

- If you make a mistake, press [Cancel] or the [Clear/Stop] key before pressing [OK], and then try again.

- 6** To enter a password, press [Password (PWD)].

- 7** Enter the password using the number keys, and then press [OK].

- 8** Press [Exit].

- 9** Press [Transmission Mode].

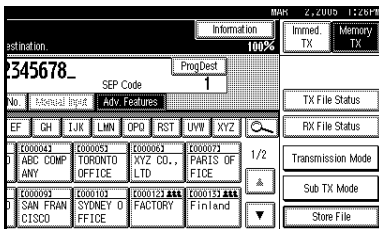

- 10** Press [Polling RX].

- 11** Press [Default ID / Free Polling RX], and then press [OK].

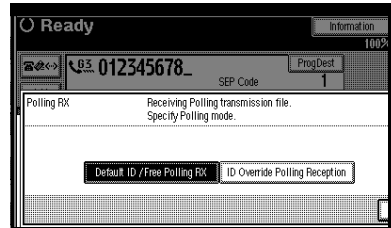

**Note**

- To cancel Polling RX, press [Cancel]. The display returns to that of step 10.

- 12** Press [OK].

The standby display appears.

- 13** Press the [Start] key.

## PWD Code

There are times you may want to use a password when receiving faxes by polling using the SEP Code function.

**Note**

- The password can be up to 20 digits long.
- You can enter numbers, \*, #, and spaces as a password.
- You can store IDs in destination lists and Programs. See “Fax Destination”, *General Settings Guide*. See p.129 “Registering and Changing Keystroke Programs”.
- Messages you send using this function are marked “PWD” on all reports.

## Transfer Request

Transfer Request allows fax machines that have this function to automatically transfer incoming messages to multiple fax destinations. This function helps you save costs when you send the same message to more than one place in a distant area, and saves time since many messages can be sent in a single operation.

The diagram below may make the concept clearer.

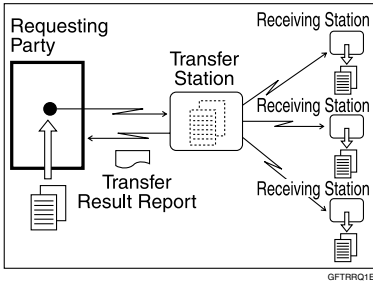

The following terminologies are used in this section:

- ◆ **Requesting Party**  
The machine where the message originates.
- ◆ **Transfer Station**  
The machine that forwards the incoming message to another destination.
- ◆ **Receiving Station**  
The facsimile or computer that received the message from the Transfer Station.

 **Preparation**  
Before you can use this function, you must make the following preparations:

- Program each Transfer Station number in this machine (Requesting Party) and in the Transfer Station itself. See p.190 "Transfer Report".
- Program the same Polling ID in both this machine (Requesting Party) and the Transfer Station. See p.192 "Programming a Polling ID".
- To send a Transfer Request by fax, the Transfer Station must be a fax machine of the same manufacturer and have the Transfer Station function.
- To send a Transfer Request by e-mail, Transfer Station must be a fax machine of the same manufacturer that supports Internet Fax.
- To send a Transfer Request by IP-Fax, the Transfer Station must be a fax machine that supports IP-Fax and made by the same manufacturer.
- You cannot use Transfer Request without programming the fax number of the Requesting Party in a Quick Dial or Speed Dial.
- The Receiving Station's fax number must be programmed in the Transfer Station's Quick Dial, Speed Dial or Group Dial.

-  **Note**
- You can specify up to 500 Transfer Stations in a Transfer Request.
  - You can have up to 30 End Receivers per Transfer Station. If you specify a Transfer Station's Group, the Group counts as a single receiver.

- ❑ When a Transfer Request is sent by e-mail, as soon as the Transfer Station completes transfer to all Receiving Stations, it sends back a Transfer Result Report by e-mail. See p.89 “Transfer Result Report (transfer request by e-mail)”.
  - ❑ When a Transfer Request is sent by e-mail to a computer or facsimile without the Transfer Request function, that machine receives it as ordinary e-mail. It does not transfer the message nor send an error report back to the Requesting Party. To send Transfer Request by e-mail, use a Transfer Station that supports Internet Fax and has the Transfer Station function.
  - ❑ You can program one of the Quick Operation keys with operations for this function. Using the key allows you to omit steps **2**. See p.144 “General Settings/Adjustment”.
- 1** Place the original, and then select any scan settings you require.

#### Note

- ❑ When using a Transfer Request by e-mail, documents are sent at “Detail” resolution, even if you have specified “Fine”. To send a document at “Super Fine” or “Fine”, configure the Full Mode when registering the destinations in the Address Book. See p.55 “T.37 Full Mode”, *Facsimile Reference <Basic Features>*.
- ❑ When using a Transfer Request by e-mail, documents are sent at A4 width. Documents larger than A4 are reduced to A4 width. If the receiver is in compliance with the T.37 full mode, documents are sent at the width specified in the Address Book. See p.55 “T.37 Full Mode”, *Facsimile Reference <Basic Features>*.

#### Reference

- p.13 “Placing Originals”, *Facsimile Reference <Basic Features>*
- p.30 “Scan Settings”, *Facsimile Reference <Basic Features>*

## **2** Specify a Transfer Station.

#### Note

- ❑ Enter directly or use a destination list to specify the fax number, e-mail address, or IP-Fax destination of the Transfer Station.
- ❑ If you make a mistake, press the **[Clear/Stop]** key, and then try again.
- ❑ When a Transfer Request is sent by e-mail, e-mail options can be set. See steps **2** and **3** on p.57 “Sending Internet Fax Documents”, *Facsimile Reference <Basic Features>*.

#### Reference

- p.35 “Entering a Fax Number”, *Facsimile Reference <Basic Features>*
- p.36 “Entering an E-mail Address”, *Facsimile Reference <Basic Features>*
- p.37 “Entering an IP-Fax Destination”, *Facsimile Reference <Basic Features>*
- p.40 “Using Destination Lists”, *Facsimile Reference <Basic Features>*

## **3** Press **[Adv. Features]**.

Reg. No.	Manual Input	Adv. Features	Search
000023	New York OFFICE	ABC COMP ANY	TORONTO OFFICE
000032	BERLIN OFFICE		XYZ CO., LTD
000043			PARIS OFFICE
000052			
000063			
000073			
000083	DETROIT FACTORY	LONDON OFFICE	SAN FRAN CISCO
000092			SYDNEY
000103			FACTORY Finland
000123			FACTORY Finland
000133			

- 4** Select [**Transfer Req.**].
- 5** Press [**Receiving Station**].
- 6** Specify a Receiving Station.

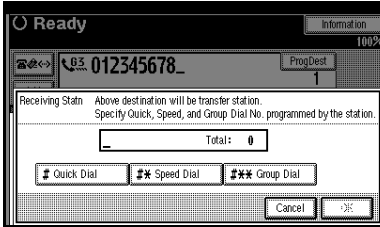

**Note**

- You cannot enter Receiving Station numbers directly. The numbers must be stored in destination lists, Speed Dial, or Groups in the Transfer Station(s). To specify a Receiving Station, use the procedure described below.
- To cancel the Transfer Request, press [**Cancel**]. The display returns to that of step **5**.

**Destination List**

- 1** Select [**# Quick Dial**].
- 2** Enter the registration number of the destination list where the Receiving Station is stored.  
For example, to select the registration number stored in Quick Dial 01 of the Transfer Station, enter: [**0**][**1**].

**Note**

- You can enter up to five digits.

**Speed Dial**

- 1** Select [**#\* Speed Dial**].
- 2** Enter the number of the Speed Dial code.

For example, to select the number stored in Speed Dial 12 of the Transfer Station, enter: [**1**][**2**].

**Group Dial**

- 1** Select [**#\*\* Group Dial**].
- 2** Enter the number of the Group number.

For example, to select the number stored in Group Dial 04 of the Transfer Station, enter: [**0**][**4**].

- 7** To specify another Receiving Station, press [**Add**].

**Note**

- Press [**▲ Prev.**] or [**▼ Next**] to see the Receiving Stations already entered. You can select a Receiving Station from this list and remove it by pressing [**Clear**] or the [**Clear/Stop**] key.

- 8** When you have specified all the Receiving Stations, press [**OK**].

- 9** Press [**Exit**].

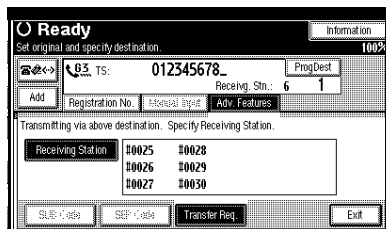

The Transfer Stations and Receiving Stations are displayed.

- 10** Press the [**Start**] key.



## With transfer requests set in the system settings

You can program a Quick Dial key with Transfer Station and/or Receiving Station using the Transfer Request function in the System Settings. See “Registering the Transfer Request”, *General Settings Guide*.

- 1 Place the original down, and then select the desired settings.

### Reference

p.13 “Placing Originals”, *Facsimile Reference* <Basic Features>

p.30 “Scan Settings”, *Facsimile Reference* <Basic Features>

- 2 Press the key programmed with Transfer Request.

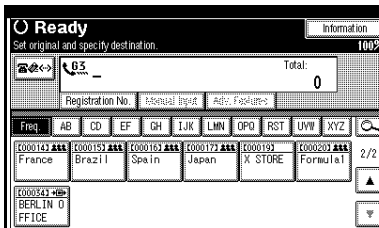

- 3 Press the **[Start]** key.

## Setting Multistep Transfer

Program a Transfer Station in a destination list. When receiving a Transfer Request that specifies the same Receiving Station as programmed in the destination list, this machine sends a Transfer Request to the programmed Transfer Station. This function allows fax messages to be transferred via multiple stations and makes fax message transfer more efficient.

You can program up to 30 Receiving Stations per Transfer Station. For more information, contact your service representative.

# On Hook Dial

The On Hook Dial function allows you to dial while hearing tone from the internal speaker. You can send a fax checking the connection.

### Limitation

- ❑ This function is not available for the optional extra G3 interface unit, Internet Fax and IP-Fax.

### Note

- ❑ This function is unavailable in some countries.
- ❑ If an Immediate TX Result Report (Immediate Transmission) is printed, On Hook Dial transmission results are not mentioned on the report.

**1** Place the original, and then select the scan settings you require.

### Reference

- p.13 “Placing Originals”, *Facsimile Reference* <Basic Features>
- p.30 “Scan Settings”, *Facsimile Reference* <Basic Features>

**2** Press the **[On Hook Dial]** key.

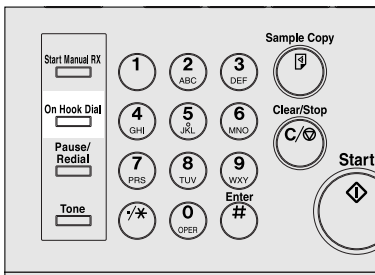

You will hear a low tone from the internal speaker.

### Note

- ❑ If you want to cancel this operation, press the **[On Hook Dial]** key again.

**3** Dial.

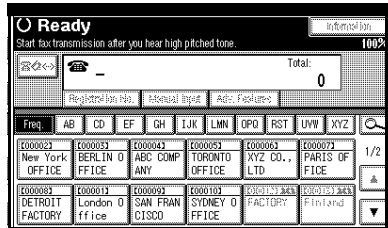

The machine immediately dials the destination.

### Note

- ❑ You can adjust the volume of the On-hook sound by pressing **[Higher]** or **[Lower]** in the upper right-hand corner of the display. The volume can also be preprogrammed in “General Settings and Adjustments”. See p.83 “Adjusting the Volume”, *Facsimile Reference* <Basic Features> and p.144 “General Settings/Adjustment”.
- ❑ If you make a mistake, press the **[On Hook Dial]** or **[Clear Modes]** key, and then return to step **2**.

**4** When the line is connected and you hear a high-pitched tone, press the **[Start]** key.

The transmission starts.

### Note

- ❑ After transmission, the machine returns to standby mode.
- ❑ If you want to cancel a transmission, press the **[Clear/Stop]** key, and then remove the originals.

  
 **External Telephone On Hook  
Dial**

If you have an external telephone on the fax machine, you can speak with the other party when you hear a voice. If you hear a voice before pressing the **【Start】** key, pick up the external telephone and tell the receiver you want to send a fax message (ask them to switch to facsimile mode).



# Manual Dial

The optional handset or an external telephone is required.

Pick up the optional handset or the handset of the external telephone and dial. When the line is connected and you hear a high-pitched tone, press the **[Start]** key to send your fax message. If, on the other hand, you hear a voice at the other end, continue conversation as normal.

### 4 Limitation

- ❑ This function is not available for the optional extra G3 interface unit, Internet Fax and IP-Fax.
- ❑ If Immediate TX Result Report (Immediate Transmission) is printed, the result of a transmission with Manual Dial is not mentioned in the report.

### 1 Place the original, and then select the scan settings you require.

#### Reference

p.13 "Placing Originals", *Facsimile Reference <Basic Features>*  
p.30 "Scan Settings", *Facsimile Reference <Basic Features>*

### 2 Pick up the handset.

You will hear a tone.

### 3 Dial.

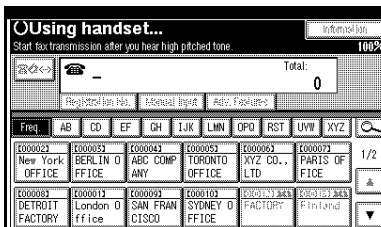

The machine immediately dials the destination.

### Note

- ❑ If you make a mistake, replace the external telephone, and then try again from step 2.

### 4 When the line is connected and you hear a high-pitched tone, press the [Start] key to send your fax message.

The transmission starts.

### Note

- ❑ If you hear a voice, tell the receiver that you want to send them a fax message (ask them to switch to facsimile mode).

### 5 Replace the handset.

After transmission, the standby display appears.

### Note

- ❑ If you want to cancel a transmission, press the **[Clear/Stop]** key, and then remove the originals.

# Changing the Line Port

The optional extra G3 interface unit is required.

When the extra G3 interface unit is installed, you can connect to a maximum of three ports.

**Note**

- When you install the extra G3 interface unit, you can specify the line port home position from "General Settings and Adjustment". See p.144 "General Settings/Adjustment".
- When sending a fax, you can select the line port if dialing with the number keys or Chain Dial.

**G3**

G3 is selected after power up or when the machine is reset. If you install the extra G3 interface unit, you can select "G3-1", "G3-2", "G3-3", or "G3 Auto" depending on the number of the installed unit.

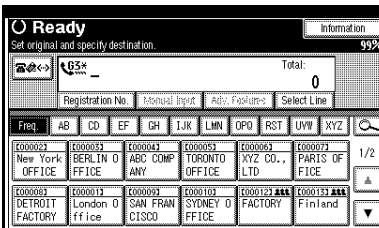

**Multi-port**

When the extra G3 interface unit is installed, communications can take place simultaneously through three lines at once.

The following list shows protocol combinations available for each line type.

Option	Available line types	Available protocol combinations
Without option	PSTN	G3
Extra G3 interface unit	PSTN+PS TN	G3+G3
Extra G3 interface unit + Extra G3 interface unit	PSTN + PSTN + PSTN	G3 + G3 + G3

**Note**

- A maximum of three simultaneous communications are possible. You cannot perform three Immediate Transmissions simultaneously.
- If three communications are in progress, the display shows the first communication that was initiated

**1** Press [Select Line].

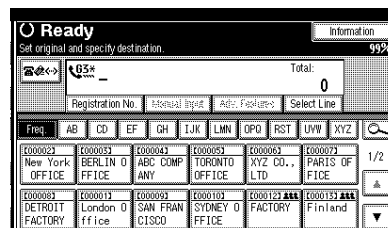

**2** Select the line you want to use.

When one optional extra G3 unit is installed.

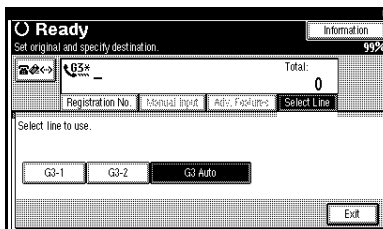

**Note**

- If you select "G3 Auto", the machine will use any available line. This increases efficiency.

**3** Press [Exit].

The standby display appears.

4

# Sub Transmission Mode

## Book Fax

Use to send book originals from the exposure glass. Pages are scanned in the order shown below.

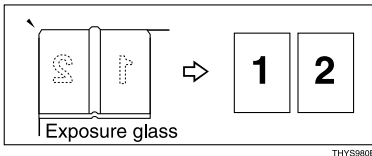

### Limitation

- Place the original on the exposure glass. You cannot use the optional ADF.
- Depending on paper sizes available in the destination machine, the message may be reduced when printed at the other end.

### Note

- You can have bound originals scanned as left or right page first. You can set which page (left or right) the machine scans first as default with the User Parameters. See p.166 "User Parameters" (switch 06, bit 6).
- When using the Internet Fax function, documents are sent at A4 width. Documents larger than A4 are reduced to A4 width. See p.13 "Placing Originals", *Facsimile Reference* <Basic Features>. If the receiver is T.37 full mode compliant, documents are sent at the width specified in the Address Book. See p.55 "T.37 Full Mode", *Facsimile Reference* <Basic Features>.

- 1** Place the original on the exposure glass, and then select the scan settings you require.

### Reference

p.13 "Placing Originals", *Facsimile Reference* <Basic Features>

p.30 "Scan Settings", *Facsimile Reference* <Basic Features>

- 2** Press [Sub TX Mode].

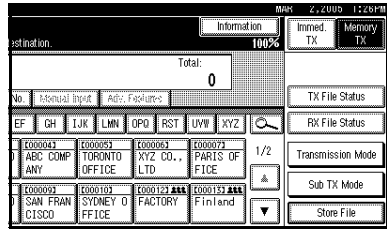

- 3** Press [Book Fax].

- 4** Select the size of the original.

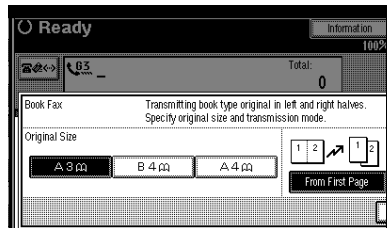

### Note

- To cancel this mode, press [Cancel]. The display returns to that of step 1.
- If you select A3, the original will be sent using Image Rotation Transmission. See p.79 "Transmission with Image Rotation".

**5** Select **[From First Page]** or **[From Second Page]**, and then press **[OK]**.

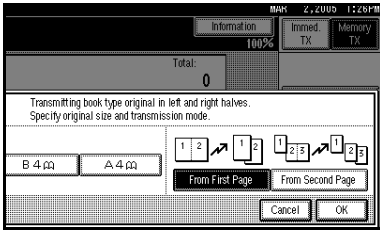

The selected original size is shown above the highlighted **[Book Fax]**.

**Note**

- Select **[From First Page]** to send a book original from the first page.
- Select **[From Second Page]** if you want to send a cover letter as the first page.
- To cancel this mode, press **[Cancel]**. The display returns to that of step **3**.

**6** Press **[OK]**.

**7** Specify a destination, and then press the **[Start]** key.

**Note**

- When sending more than one page, place the originals individually, one after the other, pressing the **[Start]** key after each page.
- After the last original has been scanned, press **[⊕]**.
- If **[⊕]** is not pressed, the machine will automatically start sending the documents, 60 seconds after the last original has been scanned.

## Two-Sided Transmission (Double-Sided Transmission)

The optional ADF is required.

Use this function to send two-sided originals.

**Note**

- Originals placed on the exposure glass cannot be sent.
- The front and back of the scanned original will be printed in order on separate sheets at the other end. The orientation of alternate sheets may be reversed at the other end. If you want to print the original with the same orientation at the other end, specify the "Original Position" and "Page Opening Orientation".

	Original	Original position	Page opening orientation	Output at the other end
A3, B4, JIS, A4, 11" x 17", 8 1/2" x 14", 8 1/2" x 11"			Top to Top	
			Top to Bottom	
			Top to Top	
			Top to Bottom	
A3, B4, JIS, A4, 11" x 17", 8 1/2" x 14", 8 1/2" x 11"			Top to Top	
			Top to Bottom	
			Top to Top	
			Top to Bottom	
B5, JIS, A5, 8 1/2" x 5 1/2"			Top to Top	
			Top to Bottom	
			Top to Top	
			Top to Bottom	

GHPY020E



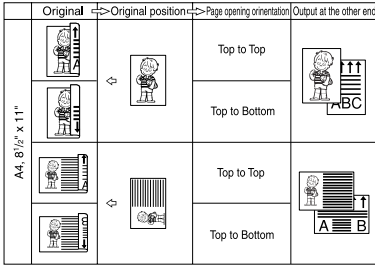

See p.79 “Transmission with Image Rotation”

- This function is only available with Memory Transmission.
- This function is only available with the ADF.
- You can confirm whether both sides were properly scanned using the Stamp function. See p.72 “Stamp”.
- You can program one of the Quick Operation keys with operations for this function. Using the quick operation keys allows you to omit step 2. See p.144 “General Settings/Adjustment”.

**1** Place the original in the ADF, and then select the scan settings you require.

**Reference**

- p.13 “Placing Originals”, *Facsimile Reference* <Basic Features>
- p.30 “Scan Settings”, *Facsimile Reference* <Basic Features>

**2** Press [Sub TX Mode].

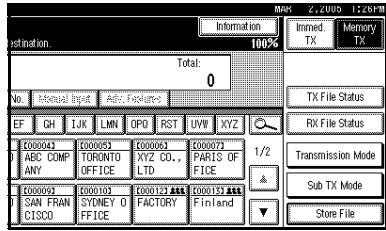

**3** Press [2 Sided Original].

**4** Specify the original position.

Check the orientation of the placed document, and then press or .

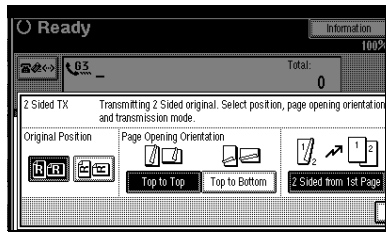

**Note**

- Make sure that the specified original position matches the orientation of originals loaded in the ADF.

**5** Specify the page opening orientation from [Top to Top] or [Top to Bottom].

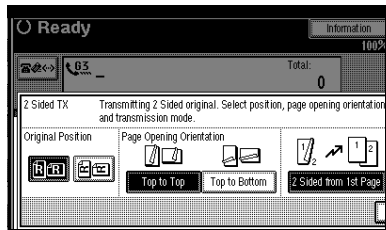

4

**6** Specify the transmission mode from [2 Sided from 1st Page] or [1 Sided for 1st Page], and then press [OK].

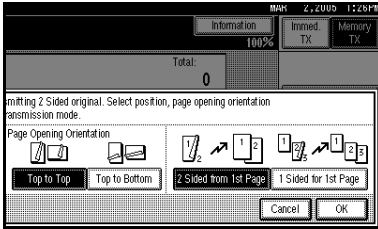

The selected original position and page opening orientation are shown above the highlighted [2 Sided Original].

**Note**

- To cancel this mode, press [Cancel]. The display returns to that of step 3.
- Select [2 Sided from 1st Page] to send a two-sided original from the first page.
- Select [1 Sided for 1st Page] if you want to send a cover letter as the first page.

**7** Press [OK].

**8** Specify the destination, and then press the [Start] key.

## Standard Message Stamp

Use this function to stamp a standard message at the top of the first original sent.

There are four types of standard messages: "Confidential", "Urgent", "Please phone", and "Copy to corres ..."

You can also program other messages.

**Note**

- While this function is in use, the third line of the Label Insertion is not printed. See p.75 "Programming the Label Insertion".
- When there is an image around the area where the standard message is to be stamped, that image is deleted.
- To program a standard message, use the Program / Change / Delete Standard Message function. See p.157 "Programming, Changing, and Deleting Standard Messages".

**1** Place the originals, and the select the scan settings you require.

**Reference**

p.13 "Placing Originals", *Facsimile Reference* <Basic Features>

p.30 "Scan Settings", *Facsimile Reference* <Basic Features>

**2** Press [Sub TX Mode].

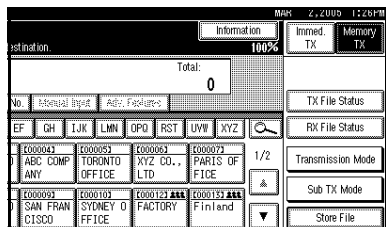

**3** Press [Std. Message].

- 4** Select the standard message to be stamped, and then press **[OK]**.

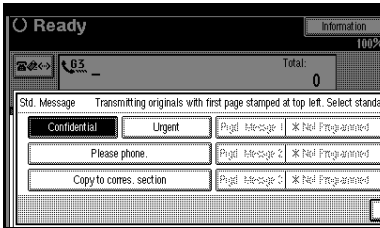

The selected standard message is shown above the highlighted **[Std. Message]**.

**Note**

- To cancel the selection, press **[Cancel]**. The display returns to that of step **3**.
- Programmed standard messages are shown in the keys.
- The machine cannot stamp multiple standard messages.

- 5** Press **[OK]**.

- 6** Specify the destination, and then press the **[Start]** key.

## Sending an Auto Document

If you often send a particular page to people (for example a map, a standard attachment, or a set of instructions), store that page in memory as an Auto Document. This saves rescanning every time you want to send it.

You can fax an Auto Document by itself, or attach it to a standard fax message.

**Preparation**

You need to register an Auto Document. See p.158 "Storing, Changing, and Deleting an Auto Document".

**Note**

- You can attach one Auto Document to each transmission.
- You can store up to 6 Auto Documents. See p.158 "Storing, Changing, and Deleting an Auto Document".
- Files with Auto Documents are sent by Memory Transmission.
- When sending an Auto Document with other files, the Auto Document is sent first.
- Storing Auto Documents reduces the amount of free memory slightly. Unless you delete the document, free memory will not return to 100%.
- You can print an Auto Document currently stored in memory. See p.66 "Printing documents stored as Auto Documents".
- You can program one of the Quick Operation keys with operations for this function. Using the quick operation keys allows you to omit step **2**. See p.144 "General Settings/Adjustment".

- 1** Place the original, and then select the scan settings you require.

**Reference**

- p.13 "Placing Originals", *Facsimile Reference* <Basic Features>
- p.30 "Scan Settings", *Facsimile Reference* <Basic Features>

**Note**

- When you fax an Auto Document, start from step **2**.

**2** Press [Sub TX Mode].

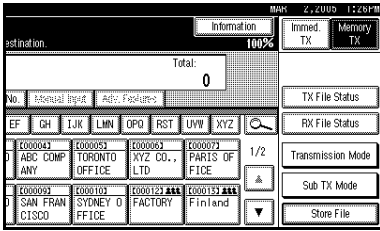

**3** Press [Auto Document].

**4** Select an Auto Document file, and then press [OK].

When you fax an Auto Document by itself, press [TX Stored File (AD) Only], and then press [OK].

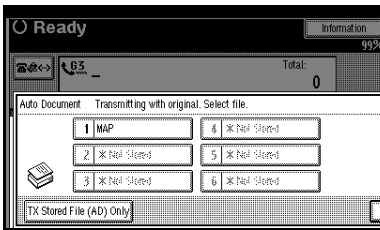

The selected file name is shown above the highlighted [Auto Document].

**Note**

- Programmed Auto Documents are shown in the keys.
- To cancel the Auto Document, press [Cancel]. The display returns to that of step 3.

**5** Press [OK].

**6** Specify the destination, and then press the [Start] key.

**Printing documents stored as Auto Documents**

This function is used for printing documents stored as Auto Documents. This function is very convenient as it can be used for checking the contents of stored files.

**1** Press [Sub TX Mode].

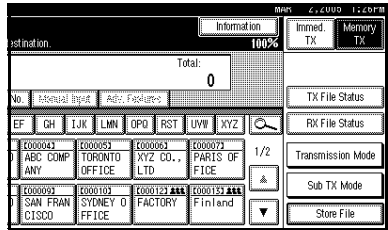

**2** Press [Auto Document].

**3** Select an Auto Document file to be printed, and then press [Print File].

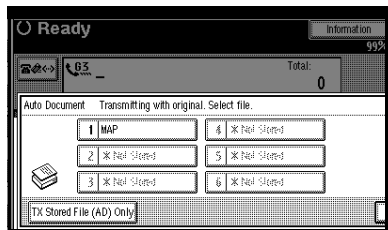

**Note**

- To cancel the Auto Document, press [Cancel]. The display returns to that of step 2.

**4** Press the [Start] key.

Once printing is completed, the display returns to that of step 2.

**Note**

- To cancel printing after pressing the [Start] key, press [Stop Printing]. The display returns to that of step 2.

**5** Press [Cancel].**Note**

- You can also send Auto Documents. See p.65 "Sending an Auto Document".

**6** Press [OK].

The standby display appears.

## Sending a Stored File

Use this function to send documents stored in the Document Server. You can specify and send multiple documents, and also send them with scanned originals all at once.

You can also print stored originals with [Print File]. See p.70 "Printing stored documents".

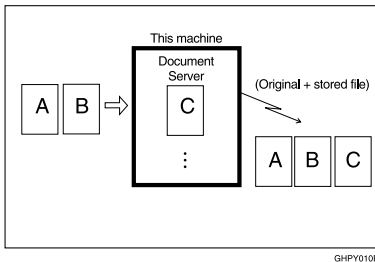
**Preparation**

Store the documents to be sent in advance. You can program a password for this function. You can change the user names, file names, and passwords of stored documents. See p.133 "Using the Document Server", and p.136 "Changing Information of Stored Documents".

**Note**

- Received fax documents are stored and categorized as stored reception files. See p.34 "Printing/Deleting Received and Stored Documents (Print/Delete Stored RX File)".
- You can program one of the Quick Operation keys with operations for this function. Using the quick operation keys allows you to omit step **1**. See p.144 "General Settings/Adjustment".

## Sending stored documents

The machine sends documents stored in the Document Server.

The documents stored in the Document Server can be sent again and again until they are deleted. Once sent, documents are stored in the Document Server. Therefore, you can send them in just one operation without having to set your originals again.

**Limitation**

- You cannot use the following transmission methods:
  - Free Polling Transmission
  - Default ID Transmission
  - ID Override Transmission
  - Immediate Transmission
  - Parallel Memory Transmission
  - On Hook Dial
  - Manual Dial

**Note**

- You can specify and print multiple documents. You can specify a maximum of 30 documents at once.
- The machine can send a total of 1,000 pages in one operation.

- The specified documents are sent with the scan settings made when they were stored.

**1** Press [Sub TX Mode].

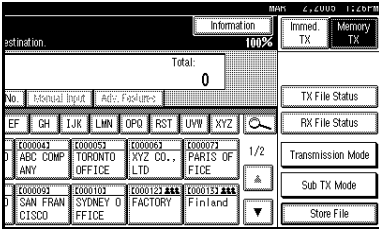

**2** Press [Select Stored File].

**3** Select the documents to be sent.

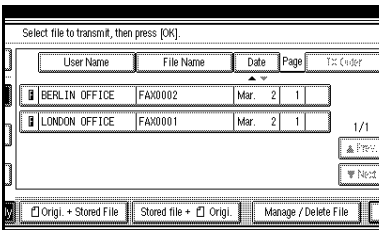

**Note**

- When multiple documents are selected, they are sent in the order of selection.
- Press [TX Order] to arrange the order of the documents to be sent.
- Press [File Name] to place the documents in alphabetical order.
- Press [User Name] to place the documents in order by programmed user name.
- Press [Date] to place the documents in order of programmed date.

Specifying documents from the file list

- 1** Press [▲ Prev.] or [▼ Next] to display the documents to be sent.
- 2** Select the file.

Specifying documents from the User Name

- 1** Select [Search by User Name].

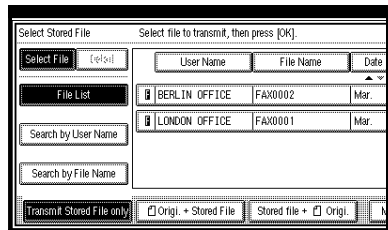

- 2** Select the user name of the programmed document, and then press [OK].

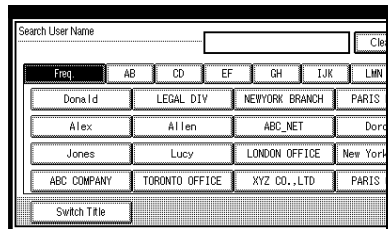

**Note**

- To search by user name, press [Non-programmed Name], and then enter the user name. Partial matching is used when searching for a user name. See p.172 "Using Partial matching".

**Reference**

"Entering Text", *General Settings Guide*

- 3** Select the file to be sent.

## Specifying documents from the file name

### 1 Select [Search by File Name].

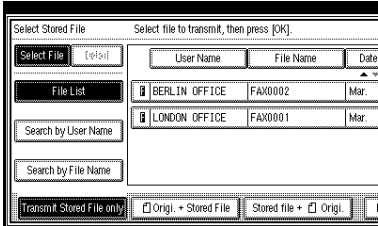

### 2 Enter the name of the document to be sent, and then press [OK].

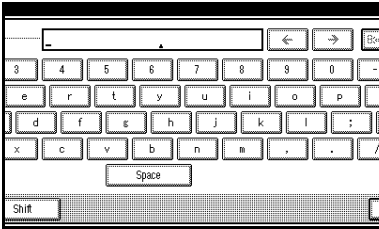

#### Note

- Partial matching is used when searching for a file name.

### 3 Select the file to be sent.

### 4 If you select a document with a password, enter the password, and then press [OK].

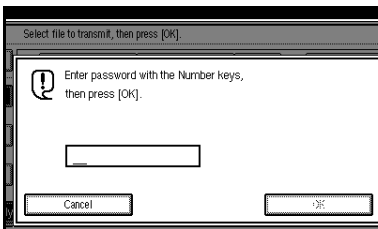

If the document does not have a password, proceed to step **5**.

### 5 When you want to add your originals to stored documents and send them all at once, press [**Orig. + Stored File**] or [**Stored file + Orig.**].

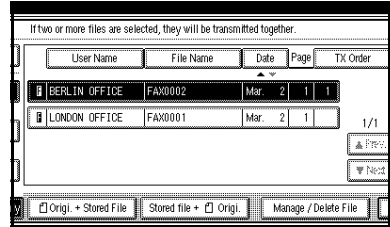

When sending only stored documents, proceed to step **6**.

#### Note

- When [**Orig. + Stored File**] is pressed, the machine sends the originals and then stored files. When [**Stored file + Orig.**] is pressed, the machine sends the stored files and then originals.
- The added originals are not stored.

### 6 Press [OK] twice.

#### Note

- To add an original to stored documents, place the original, and then select any scan settings you require.

### 7 Specify the destination, and then press the [Start] key.

## Printing stored documents

Use this function to print documents stored in the Document Server.

**Note**

- Only documents stored using the facsimile function can be printed.
- You can print documents saved from the copy or the printer function with the Document Server. You cannot print documents saved from the scanner function with this mode.
- You can also print the first page only to check the content of the original.
- You can specify and print multiple documents. You can specify a maximum of 30 documents at one time.

**1** Press [Sub TX Mode].

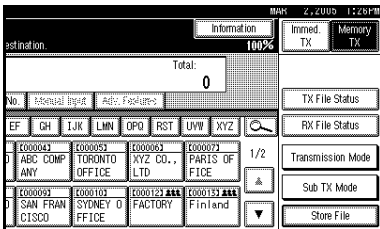

**2** Press [Select Stored File].

**3** Select the document to be printed.

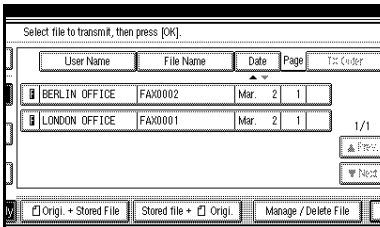

**Note**

- The documents stored using the facsimile function appear on the display.

- Press [File Name] to place the documents in alphabetical order.
- Press [User Name] to place documents in order of programmed user name.
- Press [Date] to place the documents in order by the programmed date.
- To see details of the selected document, press [Detail]. To return to the display in Step 3, press [Select File].

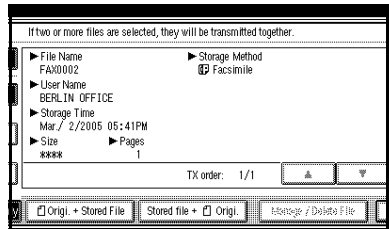

## Selecting a document from file list

**1** Select the file.

**Note**

- Press [▲ Prev.] or [▼ Next] to display the document to be sent.

## Specifying a document from the User Name

**1** Select [Search by User Name].

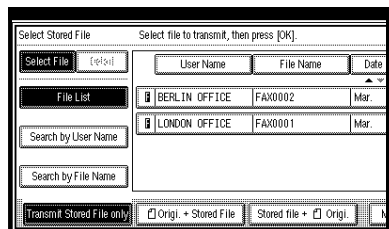



- 2 Press the user name of the document to be sent, and then press [OK].

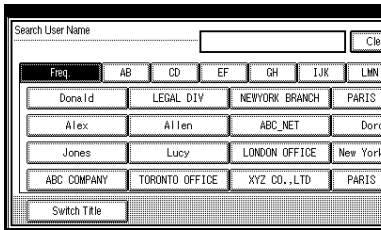

**Note**

- To search by user name, press [Non-programmed Name], and then enter the user name.

- 3 Select the file.

### Specifying a document from the file name

- 1 Press [Search by File Name].

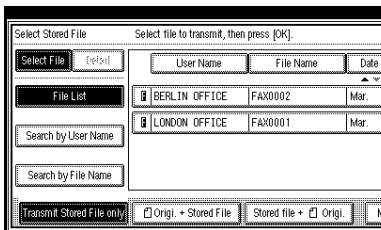

- 2 Enter the file name to be printed, and then press [OK].

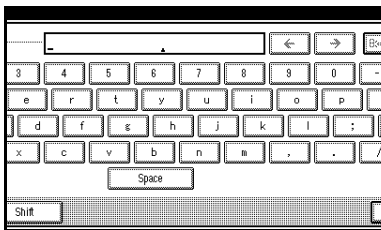

**Note**

- Partial matching is used to search for the file name.

- 3 Select the file.

- 4 If you select a document with a password, enter the password, and then press [OK].

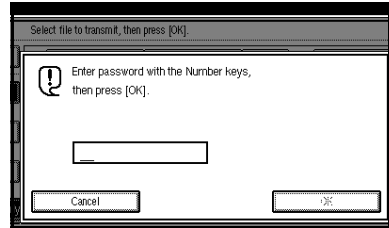

If the document does not have a password, proceed to step 5.

- 5 Press [Print File] or [Print 1st Page].

When [Print File] is pressed, the machine prints all the pages. When [Print 1st Page] is pressed, the machine prints only the first page.

**Limitation**

- When [Print 1st Page] is selected, originals larger than A4 size are printed after they are reduced to A4 size.
- The machine can print up to 30 files using the Print 1st Page function.

**Note**

- To print both sides, press [Print 2 Sided].
- To cancel printing, press [Cancel].

- 6 Press the [Start] key.

**Note**

- When only the first page is printed, the file name is printed at the top of the paper.
- To cancel printing after pressing the [Start] key, press [Stop Printing].

- 7 Press [OK] twice.

The standby display appears.

## Stamp

*The optional ADF is required.*

When sending a fax message using the ADF, the machine can stamp a circle mark at the bottom of the original. When sending a two-sided document, the document is marked at the bottom of the front page and top of the rear page. This stamp indicates that the original has been successfully stored in memory for Memory Transmission, or successfully sent by Immediate Transmission.

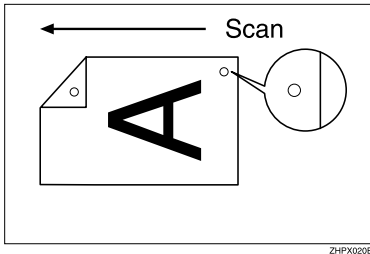

ZHPX020E

### Note

- Stamp only works when scanning from the ADF.
- When the stamp starts getting lighter, replace the cartridge. See "Replacing the Stamp Cartridge", *General Settings Guide*.
- If a page was not stamped even though the Stamp function is turned on, you need to resend that page.
- If you use this function often, you can set the default in General Settings and Adjustment so that this function is always on. In this case, Stamp can easily be turned off for any single transmission by pressing **[Stamp]**. See p.144 "General Settings/Adjustment".

- A paper jam during Parallel Memory Transmission may cause the transmission to be failed even if stamping is performed.
- You cannot turn the Stamp function on or off while a document is being scanned.

### 1 Place the original, and then select the scan settings you require.

#### Reference

p.13 "Placing Originals", *Facsimile Reference <Basic Features>*

p.30 "Scan Settings", *Facsimile Reference <Basic Features>*

### 2 Press **[Sub TX Mode]**.

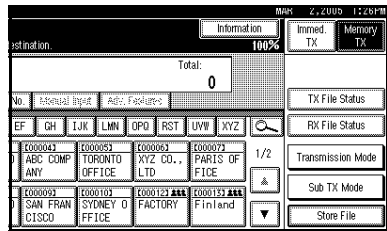

### 3 Press **[Stamp]**, and then press **[OK]**.

#### Note

- To cancel the stamp, press **[Stamp]** again before pressing **[OK]**.

### 4 Specify the destination, and then press the **[Start]** key.

## Transmission Options

This section describes various functions that you can switch on and off for any particular transmission, following the procedures given here.

In addition, if you frequently use a certain option configuration, you can change the default home position (on or off) of each option.

### Fax Header Print

In some cases, you may want the other party to receive an unmarked copy of your original. To do this, switch Fax Header off.

When the Fax Header is set to "ON", the stored name is printed on the receiver's paper.

You can store two Fax Headers; "First Name" and "Second Name".

For example, if you store your department name in one and your organization name in the other, you could use the first when sending internal faxes and the second for external faxes.

### Important

- In the USA, the Fax Header must contain the telephone number of the line your machine is connected to. It will be printed on the header of every page you send. Required in the USA.

### Note

- If you used the number keys to specify the receiver, the first header name will be printed on the receiver's paper.
- You can program fax header names using the Program Fax Information function.

- You can select whether or not dates, fax header names, file numbers, or page numbers are printed by changing their respective User Parameters. (switch 18, bit 3, 2, 1, 0) See p.166 "User Parameters".
- You can program one of the Quick Operation keys with operations for this function. See p.144 "General Settings/Adjustment".
- In the USA, law requires that your fax number be included in the Fax Header. Program the fax number and switch on Fax Header Print with User Parameters. See, p.166 "User Parameters".

### Label Insertion

With this function you can have the receiver name printed on the message when it is received at the other end. The name will be printed at the top of the page and will be preceded by "To". You can also cause the text programmed as a standard message to be printed. See p.157 "Programming, Changing, and Deleting Standard Messages".

### Note

- When there is an image around the area where the Label is to be printed, that image is deleted.
- You can program one of the Quick Operation keys with operations for this function. See p.144 "General Settings/Adjustment".

### Reduced Image Transmission

Using this function, your message is sent at a reduced size (93%) with a blank margin on the left.

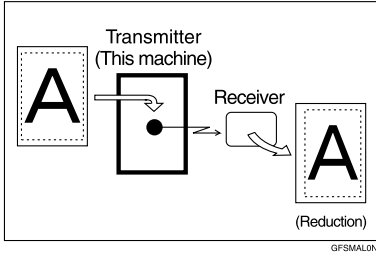

4

#### Note

- This function is unavailable with Immediate Transmission, or specified transmission of a stored document.
- Image Rotation is unavailable with this function.

### Auto Reduce

When this function is turned on, if the receiver's paper is smaller than the paper you are sending on, the message is automatically reduced to fit onto the paper available at the other end.

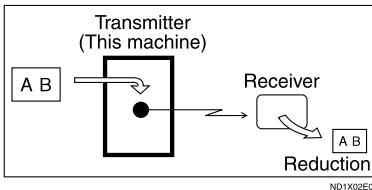

### Important

- If you turn this function off, the scale of the original is maintained and some parts of the image may be deleted when printed at the other end.

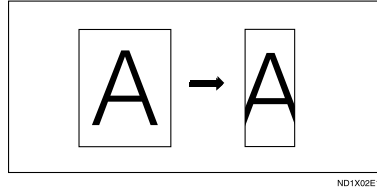

### Default ID Transmission

If you turn this function on, transmission will only take place if the destination's Polling ID is the same as yours. This function can stop you accidentally sending information to the wrong place.

#### Preparation

You need to register a polling ID beforehand. See p.192 "Programming a Polling ID".

#### Limitation

- This function is not available with Internet Fax.

#### Note

- You can program one of the Quick Operation keys with operations for this function. See p.144 "General Settings/Adjustment".

## Selecting transmission options for a single transmission

- 1 Place the original, and then select the scan settings you require.

### Reference

p.13 "Placing Originals", *Facsimile Reference* <Basic Features>

p.30 "Scan Settings", *Facsimile Reference* <Basic Features>

- 2 Press [Sub TX Mode].

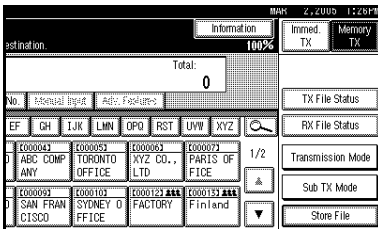

- 3 Select [Options].

- 4 Select options to be set up.

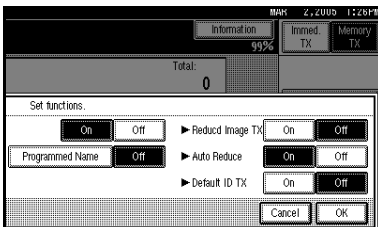
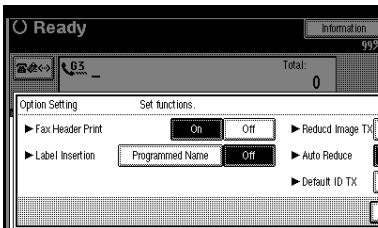

### Note

- To close the option settings, proceed to step 5.

## Programming the Fax Header Print

- 1 Press [On] for Fax Header Print.

### Note

- Press [Off] if you do not want to print the sender name.

## Programming the Label Insertion

- 1 Press [Programmed Name] for Label Insertion.

### Note

- Press [Off] if you do not want to insert a destination.

## Programming the Reduced Image Transmission

- 1 Press [On] in for Reduced Image TX.

### Note

- Press [Off] if you do not want to do a reduced transmission.

## Programming the Auto Reduce

- 1 Press [On] for Auto Reduce.

### Note

- Press [Off] if you do not want to use the Auto Reduce function.

## Programming the Default ID Transmission

- 1 Press [On] for Default ID TX.

### Note

- Press [Off] if you do not want to use ID transmission.

- 5 Press [OK] twice.

**6** Specify the destination, and then press the **[Start]** key.

 **Note**

- To cancel the option settings, press **[Cancel]**.

# More Transmission Functions

## If Memory Runs Out While Storing an Original

If you run out of memory while storing an original (free space reaches 0%), the message "Memory is full. Cannot scan more. Transmitting only scanned pages. Transmitting only scanned pages." is displayed.

Press **[Exit]** to transmit stored pages only.

### Note

- In default, scanned pages are sent. To change the settings to delete scanned pages, contact your service representative.

## Parallel Memory Transmission

This function dials while the original is being scanned. Standard Memory Transmission stores the original in memory, then dials the destination. Parallel Memory Transmission allows you to quickly determine whether a connection was made. In addition, this function scans the original faster than Immediate Transmission. This is useful when you are in a hurry and need to use the original for another purpose.

### Limitation

- Standard Memory Transmission is used instead of Parallel Memory Transmission in the following cases:
  - When the line is busy and could not be connected to
  - With Send Later

- When you store an original for Memory Transmission while another communication is in progress
- When two or more destinations are specified
- When you send only an Auto Document
- When an original is placed on the exposure glass, and then sent
- When you send messages stored in the Document Server

### Note

- You can turn this function on or off with the User Parameters. See p.166 "User Parameters" (switch 07, bit 2).
- Standard Memory Transmission may be used instead of Parallel Memory Transmission depending on the optional equipment installed if there is not enough free memory left.
- If you use this function, the Memory Storage Report will not be printed.
- If the **[Clear/Stop]** key is pressed, an original will jam or memory will run out during Parallel Memory Transmission stops. The Communication Result Report is printed and files are deleted.
- When using Parallel Memory Transmission, only the original pages are printed without automatically printing the total number of originals in "Fax Header Print".

## Checking the Transmission Result

- Turn the Immediate TX Result Report on if you want a report to be printed after every successful transmission. See p.81 “Communication Result Report (Memory Transmission)”.
- If you leave the Immediate TX Result Report off, the report will not be printed after every transmission. However, if a transmission fails, a Communication Failure Report will be printed instead. See p.81 “Communication Result Report (Memory Transmission)” and p.82 “Communication Failure Report”.
- You can also check the transmission result by examining the Journal. See p.27 “Printing the Journal”.
- You can either print or scroll through the Journal on the display. See p.31 “Checking the Transmission Result (TX File Status)”.

## Automatic Redial

If a fax message could not be sent because the line was busy or an error occurred during transmission, the line is switched to another at five-minute intervals and redial is attempted up to five times.

If redialing fails after four redials, the machine cancels the transmission and prints an Communication Result Report or Communication Failure Report. See p.82 “Communication Failure Report”. and p.81 “Communication Result Report (Memory Transmission)”.

## Batch Transmission

If you send a fax message by Memory Transmission and there is another fax message waiting in memory to be sent to the same destination, that message is sent along with your original. Several fax messages can be sent with a single call, thus eliminating the need for several separate calls. This helps save communication costs and reduce transmission time.

Fax messages for which the transmission time has been set in advance are sent by batch transmission when that time is reached.

### Limitation

- This function is not available with Internet Fax and IP-Fax.

### Note

- You can turn this function on or off with the User Parameters. See p.166 “User Parameters” (switch 14, bit 2).
- The originals to be transmitted at a specific time will be sent at that time.
- If fax memory is overloaded, messages may not be sent in the order they were scanned.

## Dual Access

The machine can scan other messages into memory even while sending a fax message from memory, receiving a message into memory, or automatically printing a report. Since the machine starts sending the second message immediately after the current transmission ends, the line is used efficiently.



**Note**

- ❑ Note that during Immediate Transmission or when in User Tools mode, the machine cannot scan an original.

## Transmission with Image Rotation

Generally, place A4, 8<sup>1</sup>/<sub>2</sub>"×11" originals in the landscape orientation (☐). If you place an A4, 8<sup>1</sup>/<sub>2</sub>"×11" original in the portrait orientation (☐), the image will be sent rotated by 90°. Providing the receiver has A4, 8<sup>1</sup>/<sub>2</sub>"×11" landscape paper (☐), the message will be printed the same size as the original.

**Note**

- ❑ This function is unavailable with Immediate Transmission.
- ❑ When Image Rotation is used, all messages are sent by normal Memory Transmission.
- ❑ This function is unavailable when using Mixed Original Sizes.

## Simultaneous Broadcast

*The optional extra G3 interface unit is required.*

The Standard Broadcast function sends faxes one at a time to multiple destinations in the order of specified destinations.

The Simultaneous Broadcast function, however, can simultaneously send faxes to multiple destinations using different lines.

This results in a shorter overall transmission time.

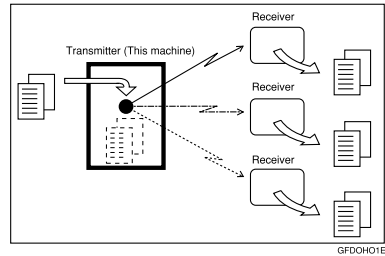
**Note**

- ❑ A maximum of four simultaneous transmissions (including LAN) are possible.
- ❑ When using the optional extra G3 interface unit, if you set the line selection as "G3 Auto" beforehand, the machine will use whichever G3 line is not busy. This increases efficiency.

## JBIG Transmission

If you use JBIG (Joint Bi-level Image Experts Group) compression, you can send photographic originals faster than with other methods of compression.

**Reference**

p.31 "Original Type", *Facsimile Reference* <Basic Features>

**Limitation**

- ❑ You can only use this function with telephone line.
- ❑ This function requires that the other party's fax machine has both the JBIG function and ECM function (G3 communication only).

**Note**

- ❑ If ECM is turned off, JBIG Transmission is unavailable. See p.165 "ECM (Error Correction Mode)".

## Transmitting Journal by E-mail

### Preparation

To transmit the Journal by e-mail, it is necessary to make settings with User Parameters. See p.166 “User Parameters” (switch 21, bit 4).

The Journal is automatically transmitted to an e-mail address of the administrator by every 50 communications. A CSV format Journal is attached to the e-mail.

### Important

- This machine does not store sent CSV files. It is recommended that you double-check the e-mail address of an administrator before the Journal is transmitted. If the e-mail address of the administrator is not correct, your important Journal may be lost and sent CSV file is not left on the fax machine. See “File Transfer”, *Network Guide*.

### Note

- If the administrator address is wrong, you may not be able to acquire Journal.
- If the Journal in e-mail format fails to be transmitted, the Journal is printed out.
- The name of an attached CSV file is “JOURNAL+year, month, hours, minutes”. For example, the file name transmitted in 14:40:12 on 20th, March, 2005 is “JOURNAL20050320144012.csv”.
- The subject of Journal by e-mail begins with “Journal”.

## Journal by E-mail

If the setting is made so that the Journal is transmitted as e-mail, it is transmitted to the e-mail address of an administrator.

This section describes the CSV format of the Journal attached with e-mail.

### Note

- To transmit the Journal, it is necessary to make settings with User Parameters. See p.166 “User Parameters” (switch 21, bit 4).
- You can display a sender name with the User Parameters. See p.166 “User Parameters” (switch 04, bit 5).
- To set the administrator e-mail address, see “File Transfer”, *Network Guide*.
- Depending on security settings, the Destination/Sender name may not appear.

# Printed Report

## Memory Storage Report

This report is printed after an original is stored in memory. It helps you review the contents and the destinations of stored originals.

### Limitation

- If you use Parallel Memory Transmission, the Memory Storage Report is not printed.

### Note

- You can turn this report on and off. See p.166 "User Parameters" (switch 03, bit 2).
- Even if the machine is set up not to print this report, it is still printed if an original could not be stored.
- You can select whether to include part of the original image on the report. See p.166 "User Parameters" (switch 04, bit 7).
- You can display a destination with the User Parameters. See p.166 "User Parameters" (switch 04, bit 4).
- You can display a sender name with the User Parameters. See p.166 "User Parameters" (switch 04, bit 5).

## Communication Result Report (Memory Transmission)

This report is printed when a Memory Transmission is completed, so you can check the result of the transmission. If E-mail TX Results is programmed in a Quick Operation key, you can select whether a report e-mail is sent after transmission. See p.146 "Quick Operation Key".

### Note

- If two or more destinations are specified, this report is printed after the fax message has been sent to all the destinations.
- If the machine is set up not to print this report and the fax message could not be successfully transmitted, a Communication Failure Report is printed. See p.82 "Communication Failure Report".
- You can turn this function on or off with the User Parameters. See p.166 "User Parameters" (switch 03, bit 0).
- You can select whether to include part of the original image on the report. See p.166 "User Parameters" (switch 04, bit 7).
- To view the report without text disruption, select a font of even character width in your e-mail application's settings.
- You can display a destination with the User Parameters. See p.166 "User Parameters" (switch 04, bit 4).
- You can display a sender name with the User Parameters. See p.166 "User Parameters" (switch 04, bit 5).
- The Page column gives the total number of pages. The Not Sent column gives the number of pages that could not be sent successfully.
- column indicates the Internet Fax document was sent to the mail server programmed in this machine. (However, this does not mean the e-mail was delivered.)

---

## Communication Failure Report

---

This report is printed when a message could not be successfully transmitted with Memory Transmission.

If the machine is set up to print an Immediate TX Result Report, this report is not printed. Use it to keep a record of failed transmissions so you can send them again.

 **Note**

- You can select whether the Communication Failure Report and Transfer Result Report be automatically printed using the User Parameters. See p.166 "User Parameters" (switch 04, bit 1).
- This report is only printed if the Immediate TX Result Report is turned off and a message could not be successfully transmitted with Memory Transmission.
- You can select whether to include part of the original image on the report. See p.166 "User Parameters" (switch 04, bit 7).
- You can display a destination with the User Parameters. See p.166 "User Parameters" (switch 04, bit 4).
- You can display a sender name with the User Parameters. See p.166 "User Parameters" (switch 04, bit 5).
- The Page column gives the total number of pages. The Not Sent column gives the number of pages that could not be sent successfully.
- Unprogrammed destination column indicates the message could not be sent because the transfer's fax number is incorrect, or not programmed.

- column indicates the Internet Fax document was sent to the mail server programmed in this machine. (However, this does not mean the e-mail was delivered.)

---

## Immediate TX Result Report (Immediate Transmission)

---

If you turn this report on, a report will be printed after every Immediate Transmission so you have a record of whether the transmission was successful or not. If the machine is set up not to print this report and the fax message could not be successfully transmitted, the Error Report is printed instead. If E-mail TX Results is programmed in a Quick Operation key, you can select whether a report e-mail is sent after transmission. See p.146 "Quick Operation Key".

 **Note**

- You can switch this report on or off in the User Parameters. See p.166 "User Parameters" (switch 03, bit 5).
- To view the report without text Disruption, select a font of even character width in your e-mail application's settings.
- You can display a destination with the User Parameters. See p.166 "User Parameters" (switch 04, bit 4).
- If the page was sent successfully, the Page column gives the total number of pages sent successfully.

# 5. Reception Features

## Reception

### Immediate Reception

Each page of a fax message is printed as soon as it is received. This method is used for standard fax messages.

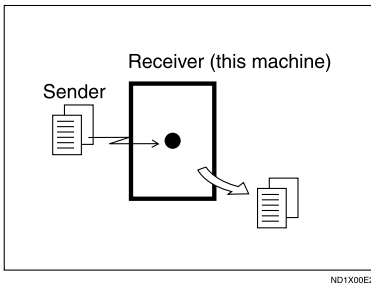

Normally this machine receives messages by Immediate Reception. But Memory Reception is used when "Combine 2 originals", "Multi-copy Reception", "RX Reverse Printing" or "2 Sided Print" is set to "ON". See p.96 "Printing Options". If the conditions are that Substitute Reception should be used, a fax message is not printed. It will be stored in memory. See p.83 "Memory Reception". See p.85 "Substitute Reception".

#### Note

- The machine may not be able to receive fax messages when free memory space is low.
- If free memory reaches 0% during Immediate Reception, any further reception becomes impossible and the current communication is terminated.

#### ◆ Reception resolution

This machine supports Standard, Detail, and Super Fine resolutions for reception. If you do not have the optional Expansion Memory, faxes sent at Super Fine resolution will be printed on your machine at Detail resolution. This may differ from the sender's intended resolution. See p.30 "Resolution", *Facsimile Reference* <Basic Features>.

### Memory Reception

The machine waits until all pages of the message have been received into memory before printing it.

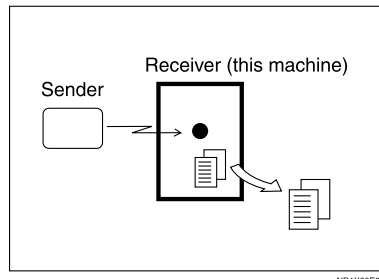

This method is used with the following functions:

- Combine 2 originals  
See p.99 "Combine Two Originals".
- Multi-copy when set to multiple copies  
See p.98 "Multi-copy Reception".
- Reverse Order Printing  
See p.100 "Reverse Order Printing".
- 2 sided Printing  
See p.97 "Two-Sided Printing".

 **Important**

- When about one hour passes after power of the machine is turned off, all fax messages stored in memory will be lost. If any messages have been lost for this reason, a Power Failure Report is automatically printed when the operation switch is turned on. Use this report to identify lost messages.
- The machine may not be able to receive large numbers of messages or messages with high data content. In such cases, we recommend you switch off the above functions or install the optional expansion memory.

 **Limitation**

- The machine may not be able to receive fax messages when free memory space is low.

 **Note**

- If the free memory space reaches 0% during Memory Reception, the machine can no longer receive the current fax message and stops communicating.
- If you have selected Store for Reception File Setting, received messages will be saved on the hard disk and will not be printed. You can print those messages by operating the machine or a connected computer, as necessary. See p.193 "Storing or Printing Received Documents".

## Substitute Reception

In Substitute Reception, a received fax message is stored in memory instead of being printed. Substitute Reception gets used when the machine cannot print any fax messages. Fax messages received using Substitute Reception are automatically printed when the condition which caused the machine to use Substitute Reception is rectified.

Depending on why the machine cannot print, Substitute Reception might be used for all fax messages received, or for only those messages that match a specified condition.

The Receive File indicator lights to let you know when fax messages have been received using Substitute Reception.

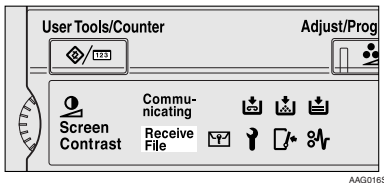

### Note

- Reception may not take place if there is not enough free memory.
- If free memory reaches 0% during Substitute Reception, any further reception becomes impossible and the current communication is terminated.
- When a fax message is received after Store has been selected for Reception File Setting in the Facsimile Features menu, the Receive File indicator lights.





## Receiving messages unconditionally

If one of the conditions listed below occurs, the machine receives all fax messages using Substitute Reception.

Problems	Causes	Solutions
is lit.	Paper is jammed.	Remove the jammed paper. See " Clearing Misfeeds", <i>General Settings Guide</i> .
The machine is printing with other function.	The machine is busy printing with other function.	The message will be automatically printed after the current job finishes.
The message "Following output tray is full. Remove paper." appears.	The output tray is full.	Remove paper from the output tray.
is lit.	The cover is open.	Close the cover shown in the display.

## Receiving messages according to parameter-specified settings

If one of the conditions listed below occurs, the machine receives only those messages that match the conditions specified in the User Parameters. See p.166 “User Parameters” (switch 05, bit 2,1).

Problems	Causes	Solutions
 is lit.	All trays out of paper.	Add paper. See “  Loading Paper”, <i>General Settings Guide</i> .
 is lit.	Toner is empty.	Replace the toner cartridge. See “  Adding Toner”, <i>General Settings Guide</i> .
The message “This tray is out of order.” appears.	All trays out of action.	Call your service representative.

You can specify the following conditions with the User Parameters. See p.166 “User Parameters” (switch 05, bit 2,1).

### ❖ When Own Name or Own Fax Number is received

The machine switches to Substitute Reception only when the sender has programmed their Own Name or Own Fax Number. If the power is switched off for more than an hour, all the messages stored in memory are deleted. In that case, the Power Failure Report or the Journal can be used to identify which messages are lost so you can ask the senders to transmit them again.

#### Important

- If a sender has not programmed their Own Name or Own Fax Number, the machine may fail to receive an important fax message. We recommend that you ask important senders to program an Own Name or Own Fax Number in advance.

### ❖ Free

The machine switches to Substitute Reception regardless of whether or not the sender has programmed their Own Name or Own Fax Number.

### ❖ Polling ID match

The machine switches to Substitute Reception only when the programmed Polling ID of the other end matches the ID of this machine.

### ❖ Disable

The machine does not receive any messages.



# Reception Functions

## Transfer Station

Transfer Stations allow you to expand the standard functions of your fax machine to set up complex networks.

The diagram below may make the concept clearer.

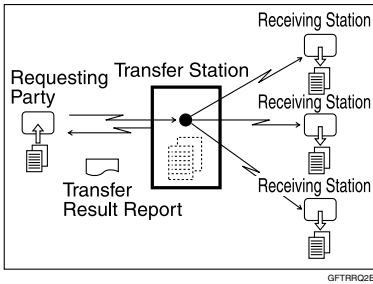

The following terminologies are used in this section:

### ◆ Requesting Party

The machine where the message originates.

### ◆ Transfer Station (this machine)

The machine that forwards the incoming message to another destination.

### ◆ Receiving Station

The facsimile or computer that received the message from the Transfer Station.

The final destination of the message, that is the machine the Transfer Station sends to. Receiving Stations must be programmed into a Quick Dial or Groups in the Transfer Station.

### 📄 Preparation

This machine can receive forwarding requests by e-mail. Before you can use this function, you must make the following preparations.

- Program each Transfer Station number in this machine (Transfer Station) and in the Requesting Party itself. See p.190 "Transfer Report".
- Program the same Polling ID in both this machine (Transfer Station) and the Requesting Party. See p.192 "Programming a Polling ID".
- The Requesting Party's fax number must be programmed in the destination list of this machine (Transfer Station). The registration number must be between 00001 and 00100.
- The End Receiver's fax number, e-mail address, or IP-Fax destination, must be programmed in the destination list or Group Dial of this machine (Transfer Station).

### 📖 Note

- You cannot receive e-mails unless your machine has the capacity to store two or more destinations specified using the number keys.
- If the Requesting Party specifies a Group for the Receiving Stations and the total number of Receiving Stations exceeds 500, the Transfer Station cannot transfer the message and sends a Transfer Result Report to the Requesting Party.

- If the Requesting Party specified a destination fax number, Internet Fax destination and IP-Fax destination programmed in Transfer Station as End Receiver, this machine sends the message to the destination according to the User Parameter setting. See p.166 "User Parameters" (switch 32, bit 0).

### Multistep transfer

The principles of Transfer Stations can be used to build up a multi-step facsimile network where messages are passed through several Transfer Stations. By programming the Receiving Stations in a Transfer Station Group, you can enable this machine to transfer messages onto other Transfer Stations.

For more information, contact your service representative.

This function can only be used if the machines are made by the same manufacturer.

### Sending the Transfer Result Report

This machine compares the fax number of the Requesting Party with the Requesting Party's number programmed as a Quick Dial or Speed Dial. If the lower five digits of the two numbers match, it sends the Transfer Result Report to the Requesting Party.

For example:

- Requesting Party's own dial number:  
**001813-11112222**
- Transfer Station's Quick Dial:  
**03-11112222**

## Transfer Result Report

### Preparation

Program the Requesting Party fax number into a Quick Dial key in the Transfer Station (this machine) in advance.

Program your own fax number. See p.190 "Transfer Report".

Program the Polling ID. See p.192 "Programming a Polling ID".

This reports whether transmission to the Receiving Stations was successful or not.

When the Transfer Station has transferred the message to all Receiving Stations, it sends the Transfer Result Report back to the Requesting Party. The machine prints the report if it cannot be sent back to the Requesting Party.

### Note

- You can select whether the Communication Failure Report and Transfer Result Report be automatically printed using the User Parameters. See p.166 "User Parameters" (switch 04, bit 1).
- You can set whether a portion of the original image is printed on the report with the User Parameters. See p.166 "User Parameters" (switch 04, bit 7).
- Unprogrammed destination column indicates the message could not be sent because the end receiver's address is incorrect or not programmed.
- column indicates the Internet Fax document was sent to the mail server programmed in this machine.

---

**Transfer Result Report (transfer request by e-mail)**

---

When this machine receives a transfer request by e-mail, the Transfer Result Report is sent by e-mail to the Requesting Party after completing all transmissions to the specified Transfer Stations. If the Administrator's e-mail address has been programmed, the Transfer Result Report e-mail is forwarded to that address.

** Note**

- Unprogrammed destination column indicates the message could not be sent because the end receiver's address is incorrect or not programmed.
- column indicates the Internet Fax document was sent to the mail server programmed in this machine.
- When using multistep transfer, the Transfer Result Report e-mail is sent to the last Transfer Station that sent Transfer Request.

## Forwarding Received Documents

This machine can forward received documents to other destinations programmed in memory based on Own Name, Own Fax Number or sender's e-mail address. A fax number, Internet Fax address, IP-Fax address, or folder address can be set as a Transfer Box. If a sender's e-mail address is programmed as the destination, documents received are forwarded as e-mail.

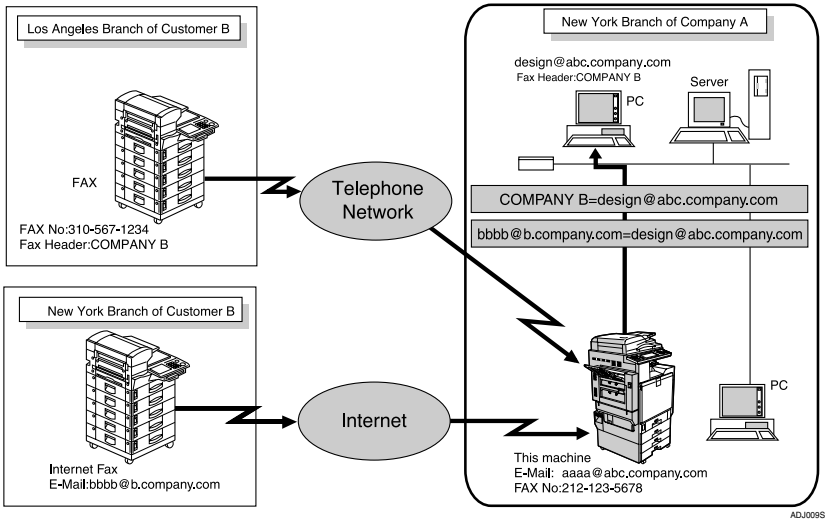

ADJ0098

### ⚠ Limitation

- A maximum of 500 parties can be specified in a group.

### 📝 Note

- You need to specify the Forwarding destination in advance. See p.162 "Forwarding".
- If you want to forward documents to a different destination depending on the sender, see p.171 "Special Senders to Treat Differently".
- You can select whether the machine prints out the messages it forwards with User Parameters (switch 11, bit 6). For details, see p.166 "User Parameters".

## Routing Received Documents with SUB Code

When a document is received, its SUB Code is compared to user codes programmed in Personal Boxes and, if a match is found, the document is routed to the destination whose user code is specified. If the destination specified is an e-mail address, the received document is routed to that destination as e-mail.

In addition to SUB Codes, you can use the forward feature to send all received transmissions to a specific e-mail address. See p.162 "Forwarding".

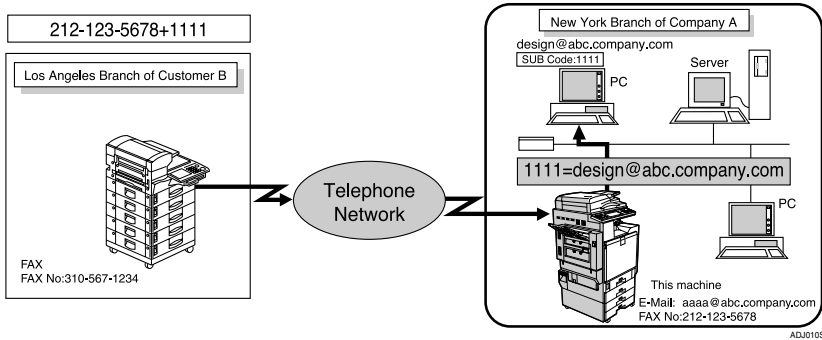

### Preparation

You must set the Personal Box and register a deliver destination beforehand. See p.181 "Programming/changing Personal Boxes".

### Limitation

- This function is not available when you set received documents to be delivered to the network delivery server.

### Note

- You can route documents received from any fax machine, regardless of manufacturer.

## Transferring Received Documents

Originals sent with a SUB Code that matches the SUB Code programmed as a Transfer Box are received then relayed to the programmed receiver.

When e-mail addresses are programmed in the Transfer Station as receivers, received messages are sent in an e-mail format to the receivers.

### Preparation

Transfer Boxes and Receiving Stations must be set up in order to transfer received documents. See p.186 "Programming/changing Transfer Boxes".

### Note

- Transfer Results are not sent back to Requesting Party.
- You can transfer data received from any fax machine, regardless of manufacturer.

## SMTP Reception Using Internet Fax

You can set this machine to SMTP reception.

With SMTP reception, e-mail is received as soon as it is sent to the e-mail address set by the machine. You can route received e-mail to other Internet Fax machines as well.

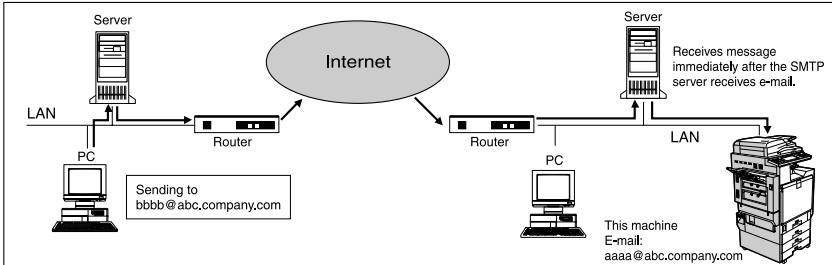

5

### Preparation

Set this machine beforehand using the MX record of the DNS server to enable SMTP reception. Also, set the reception protocol to SMTP under “System Initial Setting”. See “Connection and Setup”, *Network Guide*.

### Note

- Even if SMTP reception is enabled on the DNS server, e-mail sent from the SMTP server will not be received and the machine reports an error if SMTP reception is not set. Also, the SMTP server sends an error notification to the originator.
- If an error occurs while receiving e-mail, reception is aborted, the e-mail is deleted, and Error Report is printed. Also, the SMTP server will send an error notification to the originator.
- When the SMTP server attempts to route received documents to this machine while the machine is transmitting an e-mail, the machine will respond to the SMTP server with a “busy” signal. Then, the SMTP server usually tries re-sending the documents until the set timeout.

### Reference

p.66 “Auto E-mail Reception”, *Facsimile Reference <Basic Features>*

p.93 “Routing E-mail Received via SMTP”

## Routing E-mail Received via SMTP

E-mail received via SMTP can be routed to other fax machines. It can also be routed to destinations programmed as Quick Dial entries or Groups.

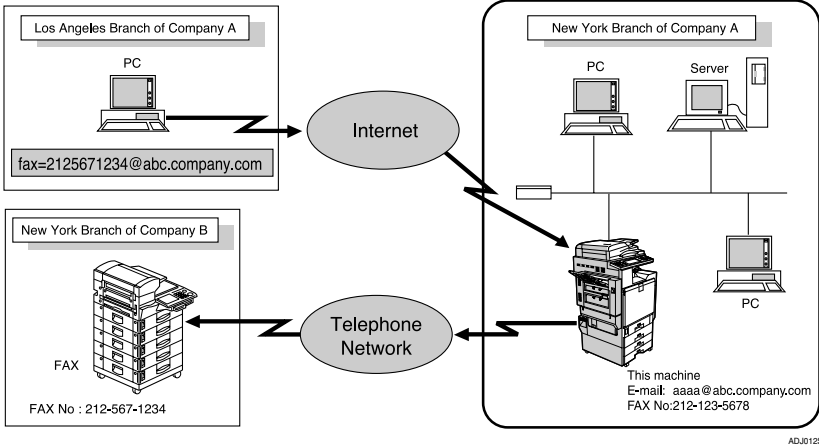

### Preparation

Before routing e-mail received via SMTP, you first must set "SMTP RX File Delivery Settings" to "On". See p.148 "E-mail Settings" .

### Limitation

- Depending on security settings, this function may not be available.

### Note

- If an e-mail transfer request is received when the "SMTP RX File Delivery Settings" to "Off", this machine responds with an error message to the SMTP server.
- You can make settings that limit transfer to specified originators. See p.148 "E-mail Settings".
- Using this function, you can also send documents from your e-mail software to e-mail addresses and G3 fax machines' destinations through this machine simultaneously. For details about specifying the destinations of fax machines, see the following.

  
 **Specifying E-mail Transfer**

The originator can request transfer of e-mail sent to another fax machine by specifying the e-mail address as follows:

◆ **Fax Number**

fax=destination fax number@host name of this machine. domain name

Example: to transfer to fax number 212-123-4567, specify:

fax=2121234567@abc.company.com

◆ **Quick Dial Destination**

fax=#registration number of 5 digits or less@host name of this machine.domain name

Example: to transfer to the destination number 00001:

fax=#00001@abc.company.com

◆ **Group Destination**

fax=#\*\*registration number of 5 digits or less@host name of this machine.domain name

Example: to transfer to the destination programmed under Group number 04:

fax=#\*\*04@abc.company.com

● **Limitation**

A maximum of 500 parties can be specified in a group.





---

## JBIG Reception

---

If you use JBIG (Joint Bi-level Image Experts Group) compression, you can send photographic originals faster than with other methods of compression. It allows you to receive messages sent in the JBIG format through JBIG Transmission.

### Limitation

- You can only use this function with telephone line.
- If ECM is turned off, JBIG Reception is unavailable. See p.165 "ECM (Error Correction Mode)".

---

## Auto Fax Reception Power-up

---

This machine can be set to shut down automatically if no one has used it for a while. In these situations, even though the operation switch is off, the machine can still receive incoming messages as long as the main power switch is on.

### Important

- Reception is not possible if both the operation switch and main power switch are turned off.

### Note

- You can set whether messages are printed as soon as they are received (Immediate Reception) with the User Parameters. See p.166 "User Parameters" (switch 14, bit 0).
- You can also have fax messages received by Memory Reception (Substitute Reception) printed after the machine is turned on.

# Printing Options

## Print Completion Beep

When this function is turned on, the machine beeps to let you know when a received message has been printed.

### Note

- You can alter the volume of the beep or turn it off completely (set the volume to the minimum level). See p.83 “Adjusting the Volume”, *Facsimile Reference <Basic Features>*.

## 5 Checkered Mark

When this function is turned on, a Checkered Mark is printed on the first page of fax messages to help you separate them.

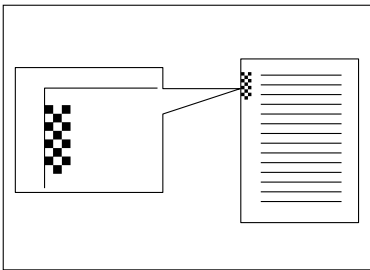

ND1X00E5

### Note

- You can turn this function on or off using Reception Setting. See p.147 “Reception Settings”.

## Center Mark

When this function is enabled, marks are printed halfway down the left side or at the top center of each page received. This makes it easy for you to position a hole puncher correctly when you file received messages.

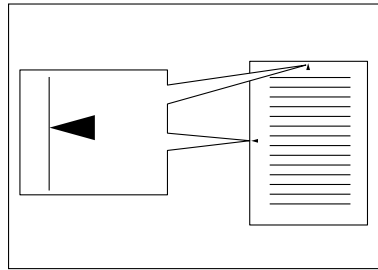

ND1X00E6

### Note

- The Center Mark may deviate a little from the exact center of the edge.
- You can turn enabled/disable this function using Reception Settings. See p.147 “Reception Settings”.

## Reception Time

You can have the date and time printed at the bottom of the message when it is received. You can turn this function on or off using Reception Settings. See p.147 "Reception Settings".

 **Note**

- When a received message is printed on two or more sheets, the date and time is printed on the last page.
- The date and time when the message was printed can also be recorded on the message. If you need this function, contact your service representative.
- You can turn this function on or off using Reception Settings. See p.147 "Reception Settings".

## Two-Sided Printing

You can have a received message printed on both sides of a sheet. You can turn this function on or off using Reception Settings. See p.147 "Reception Settings".

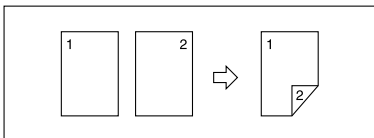

 **Limitation**

- To use this function, all pages of the received document must be of the same size—inform the sending party of this beforehand if necessary. You must also have paper set in your machine of the same size as that sent by the sending party. In Two-Sided Printing, this machine will correctly receive in A3, B4 JIS (Japanese Industrial Standard), A4, B5 JIS, A5 (11"×17", 8 1/2"×14", 8 1/2"×11", 8 1/2"×5 1/2"). The following table shows the results that can be achieved when receiving with this machine.

	Originals	Top binding	Side binding
A4, B5 JIS, A5, 8 1/2" × 11", 8 1/2" × 5 1/2"			
A3, B4 JIS, 11" × 17", 8 1/2" × 14"			

NDOX03NS

- This function works only when all pages are of the same width and received into memory.
- This function cannot be used with Combine Two Originals.
- An external tray cannot be used as a destination for two-sided printed sheets.

**Note**

- The machine will use Memory Reception for Two-Sided Printing.
- Printouts may vary depending on how the sender sets the originals.
- You can select to have messages only from selected senders printed in this way. See p.171 "Special Senders to Treat Differently".
- Stored documents of the same size are printed on the same paper. Some stored documents may be unavailable for this printing option.

**180-Degree Rotation Printing**

When printing on both sides of the paper, this machine rotates images as shown in the diagram.

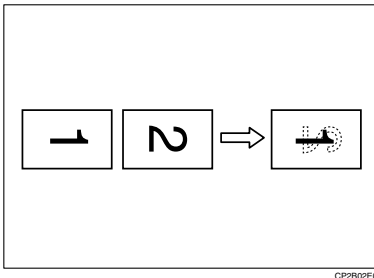

**Multi-copy Reception**

If you switch this function on, multiple copies of each incoming fax message will be printed. You can also select to have multiple copies made of messages from particular senders. See p.171 "Special Senders to Treat Differently". See p.147 "Reception Settings".

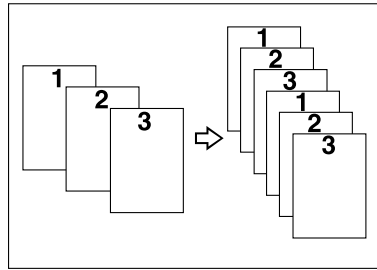

**Note**

- The maximum number of copies that can be made for each message is 10.
- When you are using the Multi-Copy function with specified senders, the maximum number of copies is 10.
- You can turn this function on or off using Reception Settings. See p.147 "Reception Settings".
- The machine will use Memory Reception for Multi-copy Reception.

## Image Rotation

If you have set paper in the standard tray , incoming fax messages will be rotated automatically to fit onto the paper.

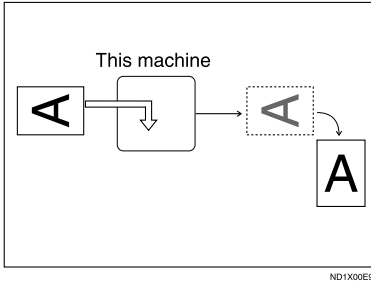

### Note

- You can choose to have received messages printed from a specified tray. See p.147 "Reception Settings".

## Combine Two Originals

When two messages of the same size and orientation are received consecutively, they are printed on a single sheet when you turn this function on. This can help you economize on paper.

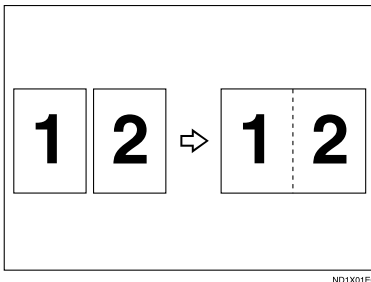

- Two A5  messages are printed side by side on a sheet of A4 .
- Two B5 JIS  messages are printed side by side on a sheet of B4 JIS .

- Two A4  messages are printed side by side on a sheet of A3 .
- Two 8 1/2"×5 1/2"  messages are printed side by side on a sheet of 8 1/2"×11" .
- Two 8 1/2"×11"  messages are printed side by side on a sheet of 11"×17" .

### Limitation

- This function does not work with messages larger than A5 , B5 JIS , A4 , 8 1/2" × 11"  or 8 1/2" × 5 1/2" . When A5 , B5 JIS , A4 , 8 1/2" × 11"  or 8 1/2" × 5 1/2"  size paper is loaded in the machine, each page of the received message is printed on a single sheet.
- If paper matching the size and orientation of a received document is unavailable, Combine Two Originals is not possible.
- When Combine Two Originals and 2 Sided Print are selected at the same time, 2 Sided Print takes priority and Combine Two Originals is canceled.

### Note

- You can turn this function on or off with the User Parameters. See p.166 "User Parameters" (switch 10, bit 1).
- This function uses Memory Reception.

## Page Separation and Length Reduction

When the size of a received message is longer than the paper loaded in the machine, each page of the message can be split and printed on several sheets, or reduced and printed on a single sheet. For example, this function splits the message if the message length is 20mm (0.79") or longer than the paper used. The message is reduced if it is less than 20mm (0.79"). When a message is split, an asterisk (\*) is inserted at the split position and about 10mm (0.39") of the split area is duplicated on the top of the second sheet.

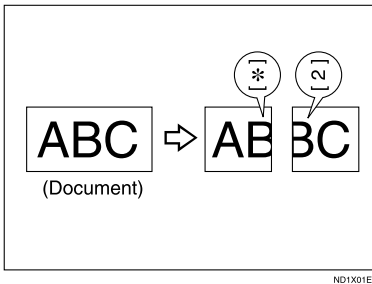

### Note

- Your service representative can customize this function with the following settings:
  - Reduction
  - Print split mark
  - Overprinting
  - Overprinting length
  - Guideline for split
- You can adjust the overprinting and reduction lengths within the following ranges:
  - Overprinting length: 4mm (0.16"), 10mm (0.39"), 15mm (0.59")

- Guideline for split: 5-155mm (5mm steps)/0.2"-6.1" (0.2" steps)

## Reverse Order Printing

Normally, received pages are printed and stacked on the tray in the order they are received. If you turn this function on, the machine will start printing the message from the last page received.

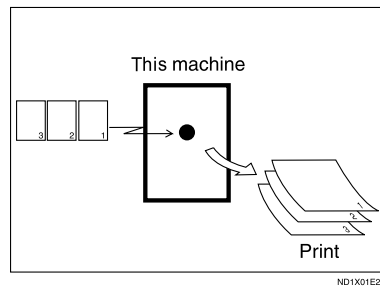

### Note

- You can turn this function on or off using Reception Settings. See p.147 "Reception Settings".
- When this function is on, the first page will be printed last.
- This function uses Memory Reception.

## Page Reduction

If you receive a message that is longer than the paper in the tray, the machine usually prints it on two pages. If you turn this function on, the machine reduces the width and length of the received image so that it will fit on one page. If A4 paper is loaded and a message of B4 JIS size is received, the machine will reduce the message to a single A4 sheet.

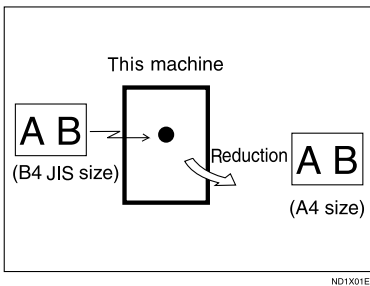

### Note

- You can turn this function on or off with the User Parameters. See p.166 "User Parameters" (switch 10, bit 3).
- When this function is used, the printing quality may not be as good as usual.

### Reference

p.100 "Page Separation and Length Reduction"

## TSI Print (Transmitting Subscriber Identification Print)

Usually the sender's Fax Header is printed on received messages. If the sender has not programmed their Fax Header, you will not be able to identify them. However, if you turn this function on, the sender's Own Name or Own Fax Number is printed instead so you can find out where the message came from. When you receive an Internet Fax document, the e-mail address of the sender is printed.

### Reference

p.75 "Initial Settings and Adjustments", *Facsimile Reference <Basic Features>*

### Note

- You can turn this function on or off in the User Parameters. See p.166 "User Parameters" (switch 02, bit 3).

## When There Is No Paper of the Correct Size

If there is no paper in your machine that matches the size of a received message, the machine will choose a paper size based on the paper available. For example, if your machine has 8<sup>1</sup>/<sub>2</sub>"x11" paper and A3 paper loaded and you receive a A4 size message, check the A4 column of the following table. The paper size at the top has highest priority. In this case, since 8<sup>1</sup>/<sub>2</sub>"x11" is given a higher priority than A3, the message is printed on 8<sup>1</sup>/<sub>2</sub>"x11" paper.

If only B5 JIS is loaded and you receive an A3 message, the received message is stored in memory and not printed.

◆ Priority Table

		Received Image Size							
		A3,DLT	B4,JIS	A4,LT	A4,LT	B5,JIS	LG	F/F4	
Paper Select Priorities	1	A3	B4,JIS	LT	A4	B5,JIS	LG	F/F4	
	2	DLT	A3	LT	A4	B5,JIS	A4	LG	
	3	A4	DLT	A4	LT	B4,JIS	A4	A4	
	4	A4	B5,JIS	A4	LT	A4	LT	A4	
	5	LT	B5,JIS	F/F4	A3	A4	LT	LT	
	6	LT	A4	LG	F/F4	LT	F	LT	
	7	F/F4	A4	A3	DLT	LT	B4,JIS	B4,JIS	
	8	B4,JIS	LT	B4,JIS	B4,JIS	F/F4	A3	A3	
	9	LG	LT	DLT	LG	A3	DLT	DLT	
	10		F/F4	HLT		DLT	HLT	HLT	
	11		LG	A5		LG	A5	A5	

Portrait  
 Landscape  
 Image Rotation

GFPR100E

Page reduction	Disabled
Reduction in Sub-scan Direction	Enabled
Page Separation Threshold	20mm (0.79")
Width or Length Priority	Width

- and indicate that the message is split over two pages of paper with the orientation and size shown.

Note

- Paper placed in the bypass tray is not usually selected for printing a received message. However, you can use this tray if you select the bypass tray as the main paper tray using Reception with Specified Senders. See p.171 "Special Senders to Treat Differently".
- Widths that this machine can receive are A4, B4 JIS, and A3. Any messages narrower than A4 are sent as A4 width with the length unchanged.

- The paper size used to print a received message may be different from the size of the sent original.
- If you specify a receiving tray with the setting priority under System Settings, the messages may be received in a different order by setting the priority table. The priority tray may be used only when the document received is the same size as the priority tray.

Reference

- p.99 "Image Rotation"
- p.100 "Page Separation and Length Reduction"
- p.101 "Page Reduction"
- "Tray Paper Settings", *General Settings Guide*

**Setting priority trays**

With the same size of paper loaded into multiple trays, you can make the machine use one tray for one function and another tray for another function. For example, you may load white A4 paper into tray 1 to use when making copies, and yellow A4 paper into tray 2 to use when printing received faxes. You can then easily identify for which purpose paper has been output. You can perform this setting using System Settings. See "Tray Paper Settings", *General Settings Guide*.

Note

- When a different size of document from the priority tray is received, the tray containing the same size of paper as the received document is used.



## Just size printing

If you enable this function, received documents are printed on the sheet that has highest priority. See p.102 "Priority Table". This function is enabled with User Parameters. See p.166 "User Parameters" (switch 05, bit 5).

If the paper tray is not stocked with paper of a suitable size to print a received document, a message appears on the display prompting you to load paper of the required size. When you have loaded new paper, press **[Exit]** to print the document.

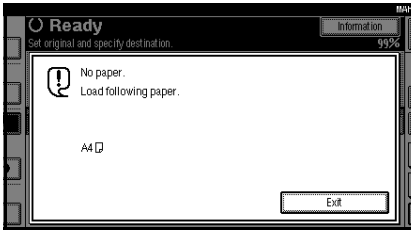

### Note

- ❑ After pressing **[Exit]**, procedure varies depending on machine status when the message occurred.
  - If any received documents or reports were being printed automatically, the printer automatically continues printing from where it left off.
  - If any documents or reports were being printed manually, the printer does not resume printing. Perform the operation from the beginning again.

## Having Incoming Messages Printed on Paper from the Bypass Tray

You can print messages sent from Specified Senders on paper from the bypass tray.

Set as follows:

- Program a special sender and select the Bypass Tray for the paper tray type. See p.178 "Programming Bypass Tray Paper Size" under "Program Special Sender".
- Turn on the Authorized RX function under the Program Special Sender function. See p.178 "Programming Authorized RX and Special RX Function".

### Limitation

- ❑ When using this function, printed sheets cannot be delivered to the finisher output tray. Even if you specify the finisher output tray, sheets are delivered to the Internal Tray 1. See "Tray Paper Settings:Fax", *General Settings Guide*.

### Note

- ❑ You can load a maximum of 100 sheets of standard paper in the bypass tray.
- ❑ You can use a size of paper not stocked in the paper tray(s) in the bypass tray.
- ❑ The machine can detect A5, A4, A3, 5<sup>1</sup>/<sub>2</sub>"×8<sup>1</sup>/<sub>2</sub>" paper sizes. When you load any other size, specify the paper size. However, if the specified paper size and size of paper set in the bypass tray do not match, paper jams may occur, or the image may be shortened. See p.178 "Programming Bypass Tray Paper Size".

- Messages printed on paper smaller than A4 may be shortened, or split across sheets.
- Paper longer than 600mm may be creased, not sent, or jam.
- Print area depends on optional expansion memory, resolution, and vertical length of originals.
- If you use this function, Image Rotation and 180-Degree Rotating Printing are not possible.

# Where Incoming Message are Delivered - Output Tray

## Specifying Tray for Lines

*The optional extra G3 interface unit is required.*

You can specify the document feeding tray for each port (telephone, Internet Fax, IP-Fax). For example, you can specify documents received through the G3 -1 port to be fed to the "Internal Tray 1" and documents received through the G3 -2 port to be fed to the "Internal Tray 2", facilitating separation of files. You can also set the machine to output Internet Faxes and ordinary faxes onto different trays.

### Note

- To use this function, specify the port and destination using **[Specify Tray for Lines]**. See p.147 "Reception Settings".

## Tray Shift

*The optional finisher is required.*

When the optional finisher unit is selected for fax output, you can use the Tray Shift function whenever a fax or report is printed.

This is useful for separating faxes stacked in the finisher output tray. For example, if the previous incoming fax was output to the left, the next incoming fax will be output to the right and vice-versa.

### Note

- You can turn this function on or off with the User Parameters. See p.166 "User Parameters" (switch 19, bit 0).



# 6. Fax via Computer

## Sending Fax Documents from Computers

Using computers connected to the machine through parallel ports, IEEE 1394 (IP Over 1394) ports, LANs, or wireless LANs you can fax documents, created using Windows applications, to other fax machines over a telephone line.

- To send a fax, simply select **[Print]** from the Windows application, then select LAN-Fax as the printer, and then specify a destination.
- In addition to sending faxes, LAN-Fax Driver allows this machine to be used for printing out documents prepared on a computer for proof checking.
- To use LAN-Fax Driver, connect this machine to a LAN and make the necessary network settings, and then install LAN-Fax Driver and related utility on your computer.

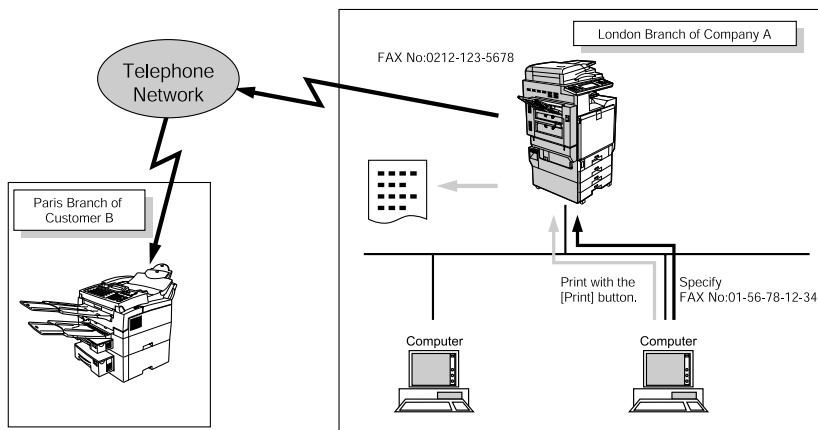

ADJ0135

### **Important**

- ❑ Errors occurring when the machine is used as a LAN-Fax will not be displayed on the computer. Check the help menus using a Web Image Monitor.

## Before Use

To use these features, a LAN-Fax Driver must be installed on your computer. Use the LAN-Fax Driver included on the printer CD-ROM. You must also make the required computer to fax network settings on the machine, according to the type of connection.

### Reference

When a personal computer and the machine are connected in parallel:

See “System Settings (Parallel Connection)”, *Printer Reference*.

When using Ethernet, IEEE 1394 (IP over 1394), or IEEE 802.11b (wireless LAN):

See “Connection and Setup”, *Network Guide*.

## Installing the Software

You need to install LAN-Fax Driver on your computer before using the LAN-Fax functions. LAN-Fax Driver is on the CD-ROM included with the printer.

Address Book and LAN-Fax Cover Sheet Editor are installed with LAN-Fax Driver. Address Book helps you edit LAN-Fax transmission destinations. LAN-Fax Cover Sheet Editor helps you edit LAN-Fax cover sheets.

### Note

- The following explanation assumes that you are familiar with general Windows procedures and practices. If you are not, see the documentation that comes with Windows for details.

## Auto run program

With Windows 95/98/Me, Windows 2000/XP, Windows Server 2003 and Windows NT 4.0, the installers for various drivers and utilities launch automatically as Auto Run programs when you insert the CD-ROM.

If your operating system is Windows 2000/XP, Windows Server 2003 or Windows NT 4.0, installing a printer driver using Auto Run requires Administrator permissions. When you install LAN-Fax Driver using Auto Run, log on using an account that has Administrator permissions.

### Note

- If the plug and play function starts, click **[Cancel]** in the **[New Hardware Found]**, **[Device Driver Wizard]**, or **[Found New Hardware Wizard]** dialog box, and then insert the CD-ROM. The **[New Hardware Found]** or **[Found New Hardware Wizard]** dialog box appears depending on the system version of Windows 95/98/Me, Windows 2000/XP, or Windows Server 2003.
- Auto Run might not work automatically with certain OS settings. If this is the case, double-click “Setup.exe”, located on the CD-ROM root directory.
- If you want to cancel Auto Run, hold down the **[SHIFT]** key (when your system is Windows 2000/Windows XP or Windows Server 2003, hold down the left the **[SHIFT]** key) while inserting the CD-ROM. Keep the **[SHIFT]** key hold down until the computer stops reading the CD-ROM.
- Clicking **[Cancel]** during installation aborts the installation. If you cancel the installation, restart your computer and install the rest of the software or printer driver.

LAN-Fax Driver, Address Book, and LAN-Fax Cover Sheet Editor can be installed by Auto Run.

---

## Installing individual applications

---

### Preparation

Before installing the above applications, install SmartDeviceMonitor for Client. See “Software and Utilities Included on the CD-ROM”, *Printer Reference*.

Use the following procedure to install LAN-Fax Driver, Address Book, and LAN-Fax Cover Sheet Editor at one time.

**1** Quit all applications currently running.

**2** Insert the CD-ROM included with this machine into the CD-ROM drive of your computer.

The installer launches automatically, and the language selection window appears.

### Note

Depending on your operating system settings, the installer may not launch automatically. If it does not, double-click “SETUP.EXE” in the CD-ROM root directory to launch the installer.

**3** Select the interface language of the software, and then click [OK].

**4** Click [LAN-Fax Driver].

The software license agreement window appears.

**5** Read all of the terms and, if you agree, select [I accept the agreement], and then click [Next].

### Note

If you select [I don't accept the agreement], you cannot complete the installation.

**6** Click the [LAN-Fax Driver] check box, and then click [Next].

**7** Confirm that the [Printer Name:<LAN-Fax M6>] check box has been selected, and then click [Continue].

### Note

Select the desired port.

**8** Click [Finish].

The installation completion dialog box appears.

**9** Click [Finish].

**10** Click [Exit].

---

## Applications Stored on the CD-ROM

---

This section provides information about LAN-Fax Driver, Address Book, and LAN-Fax Cover Sheet Editor.

---

### LAN-Fax Driver

---

This driver allows you to use LAN-Fax functions.

#### ◆ Location of the File

The following folders are on the CD-ROM:

- LAN-Fax Driver for Windows 95/98/Me  
DRIVERS\LAN-FAXWIN9X\_Me
- LAN-Fax Driver for Windows NT 4.0  
\DRIVERS\LAN-FAX\NT4
- LAN-Fax Driver for Windows 2000/XP  
DRIVERS\LAN-FAXWIN2K\_XP

### ❖ Operating Environment

- Computer  
PC/AT Compatible
- Operating Systems  
Microsoft Windows 95/98/Me  
Microsoft Windows 2000/XP  
Microsoft Windows Server 2003  
Microsoft Windows NT 4.0
- Display  
VGA 640×480 dots or more

### 🔊 Limitation

- All operations cannot be guaranteed depending on the system environment.
- When you use Windows NT, LAN-Fax Driver will not work in an RISC base processor (MIPS R series, Alpha AXP, PowerPC) environment.

### 📝 Note

- Before beginning installation, exit all other applications.

---

## Address Book

---

Address Book helps you edit LAN-Fax transmission destinations.

### ❖ Operating Systems

- Microsoft Windows 95/98/Me
- Microsoft Windows 2000/XP
- Microsoft Windows Server 2003
- Microsoft Windows NT 4.0

---

## LAN-Fax Cover Sheet Editor

---

LAN-Fax Cover Sheet Editor helps you edit LAN-Fax cover sheets.

### ❖ Operating Systems

- Microsoft Windows 95/98/Me
- Microsoft Windows 2000/XP
- Microsoft Windows Server 2003
- Microsoft Windows NT 4.0

---

## Setting LAN-Fax Driver Properties

---

### 📝 Note

- If your operating system is Windows NT 4.0, Windows 2000/XP, or Windows Server 2003, log on using an account that has Administrator rights.

---

## Setting Print Properties

---

This section describes how to make settings such as paper size or resolution.

- 1** On the [Start] menu, point to [Settings], and then click [Printers].

### 📝 Note

- With Windows XP Professional or Windows Server 2003, select [Printers and Faxes] on the [Start] menu.
- With Windows XP Home Edition, select [Control Panel] on the [Start] menu. Next select [Printers and Other Hardware], and then [Printers and Faxes].

- 2** Select to highlight [LAN-Fax M6], then click [Properties] on the [File] menu.

### 📝 Note

- With Windows NT, click [DocumentDefault] on the [File] menu.

- 3** Set the print properties.

---

When using Windows 95/98/Me

---

- 1** Click the [Paper] tab.
- 2** Set the properties as shown below.
  - Paper size
  - Orientation
  - Tray



- Resolution
- Gray scale
- Printing images of True Type fonts

---

When using Windows 2000/XP, Windows Server 2003, or Windows NT 4.0

---

- 1 Click the **[Paper Setting]** button.
- 2 Set the properties as shown below.
  - Paper size
  - Orientation
  - Tray
  - Resolution

---

### Making Settings for Option Configuration

---

Make settings for optional units installed in this machine.

 **Note**

- If the options on this machine are not configured as instructed, LAN-Fax functions may fail.
- When this machine is connected to a network, option configuration is automatically performed. For details, see LAN-Fax Driver's Help.

- 1 Perform Steps 1 and 2 in "Setting Print Properties".
- 2 Make settings for the option configuration.

---

When using Windows 95/98/Me

---

- 1 Click the **[Accessories]** tab.

---

When using Windows 2000/XP, Windows Server 2003, or Windows NT 4.0

---

- 1 Click the **[Accessories]** tab.

---

When using a network

---

- 1 If the settings do not match the installed optional units, click **[Load from Device]**.

---

When not using a network

---

- 1 Select the check box besides the installed optional units.
- 3 Click **[OK]**.  
Option configuration settings are complete.
- 4 Click **[OK]**.

 **[Accessories] tab**

The **[Accessories]** tab contains the following items besides option configuration items.

- ◆ **Prohibit manual destination entry**  
Check this option to inhibit direct destination specification.
- ◆ **Enable E-mail**  
Check this when using Internet Fax with the LAN-Fax function.
- ◆ **IP-Fax**  
Check this option when using IP-Fax, check this option.  
After checking this option, select a protocol by clicking an appropriate radio button.

 **Reference**

Protocols are configured under IP-Fax Setting. See p.150 "IP-Fax Settings".

## Basic Transmission

This section describes how to send fax documents created using Windows applications.

To send a fax, simply select **[Print]** from the Windows application, then select **[LAN-Fax]** as the printer, and then specify a destination in the **[LAN-Fax]** dialog box.

Open the application document you want to send or create a new document, and then perform the following procedure.

For details, see Help.

### Limitation

- When using SmartDeviceMonitor for Client, you cannot send documents to this machine using more than one LAN-Fax at the same time.

- 1** On the **[File]** menu, click **[Print]**.
- 2** Select **[LAN-Fax M6]** in **[Printer Name]**.
- 3** Click **[OK]**.

The LAN-Fax dialog box appears.

### Note

- The setting method may differ depending on the application you are using. In all cases, select **[LAN-Fax M6]** for the printer.

### **4** Specify the destination.

Use one of the following procedures to specify a destination. For details, see LAN-Fax Driver's Help.

### Note

- When user authentication is used with this machine, click **[User Settings]**.
- You can specify up to 500 destinations.

- Documents transmitted from LAN-Fax can be stored in this machine. The number of these documents that can be stored is as follows:

- Without cover sheet  
Standard: 400
- With cover sheet  
Standard: 200

## Specifying a destination using a destination list

- 1** Click the **[Address Book:]** or **[Fax Number]** tab.

The **[Address Book:]** or **[Fax Number]** dialog box appears.

- 2** Check the **[Device Address]** (or **[Use programmed machine's address]**) checkbox.

- 3** The machine's address is displayed in the **[Device Address]** field on the **[Address Book:]** tab. On the **[Fax number:]** tab, enter the registration number of the destination key.

- 4** Click **[Set as Destination]**.

The entered destination is added and appears in the **[List of Destinations]** box.

### Note

- If you add a destination by mistake, click the wrong destination and then click **[Delete from List]**.

- 5** To specify more destinations, repeat Steps **3** and **4**.

---

## Specifying a destination using Address Book

---

In order to use this method, you need to register destinations in the address list using Address Book. See p.110 "Address Book".

**1** Click the **[Address Book:]** tab.

The contents of the **[Address Book:]** tab are displayed.

**2** Select a CSV file containing the desired destination list, from the drop-down menu.

 **Note**

- Up to three most recently used files appear in the drop-down menu. To use a destination list that did not appear, click **[Browse]**, and then select the file.

**3** Select **[Contact]** or **[Group]** in the **[Name:]** dropdown menu as the display format.

 **Note**

- Destination list contents change as follows, depending on the option selected:

- Contact: Company name, department name, individual name, fax number
- Group: Group name

- If you selected **[Group]** from the **[Name:]** dropdown menu, proceed to Step **5**.

**4** Select the type of fax from the **[Type:]** dropdown menu.

 **Note**

- Select the fax type as follows:
  - Send by standard fax: **[Fax]**
  - Send by Internet Fax: **[E-mail]**
  - Send by IP-Fax: **[IP-Fax]**

- If you selected **[Group]** from the **[Format:]** dropdown menu, you cannot select the fax type. Proceed to Step **5**.

**5** Click the destination in the destination list to highlight it, and then click **[Set as Destination]**.

The entered destination is added and appears in the **[List of Destinations]** box.

 **Note**

- If you add a destination by mistake, click the wrong destination and then click **[Delete from List]**.

**6** To specify more destinations, repeat Steps **2** through **5**.

---

## Specifying a destination by directly entering a fax number, Internet Fax destination, or IP-Fax destination

---

**1** Click the **[Specify Destination]** tab.

The contents of the **[Specify Destination]** tab are displayed.

**2** Select the type of fax from the **[Type:]** dropdown menu.

 **Note**

- Select the fax type as follows:

- Send by standard fax: **[Fax]**
- Send by Internet Fax: **[E-mail]**
- Send by IP-Fax: **[IP-Fax]**

- After you select the fax type, a screen corresponding to the selected type appear.

**3** Specify the destination.

 **Note**

- Specify the destination depending on the selected fax type as follows:
  - When **[Fax]** is selected: enter the fax number.
  - When **[E-mail]** is selected: enter the e-mail address.
  - When **[IP-Fax]** is selected: enter the IP-Fax destination.
- You can enter up to 128 characters for the destination.
- To enter a pause in the fax number, click **[Pause]**. If you selected **[E-mail]** or **[IP-Fax]** in Step ②, **[Pause]** is not available.

 **Reference**

p.35 "Entering a Fax Number", *Facsimile Reference* <Basic Features>

p.36 "Entering an E-mail Address", *Facsimile Reference* <Basic Features>

p.37 "Entering an IP-Fax Destination", *Facsimile Reference* <Basic Features>

**4** Select a line or protocol from the **[Line:]** or **[Protocol:]** dropdown menu. **Note**

- The **[Line:]** dropdown menu is displayed when you selected **[Fax]** in Step ② while the **[Protocol:]** dropdown menu is displayed when you selected **[IP-Fax]** in Step ②. If you selected **[E-mail]** in Step ②, proceed to Step ⑤.

**5** Click **[Set as Destination]**.

The entered destination is added and displayed in the **[List of Destinations]** box.

 **Note**

- If you have added a wrong destination by mistake, click the destination by clicking it, and then click **[Delete from List]**.

**6** To specify more destinations, repeat Steps ② through ⑤.**5** Specify necessary options. **Reference**

p.114 "Specifying options".

p.116 "Confirming Transmission Results by E-mail".

**6** Click **[Send]**. **Note**

- When you click **[Send & Print]**, the fax is sent to the destination and your machine prints a copy of the document you send.

---

**Specifying options**

---

You can specify the options listed below.

For details, see LAN-Fax Driver's Help.

- Sending at a Specific Time
- Print Sender Stamp
- Attach Cover Sheet
- Two-Sided Printing
- Display Preview
- Save as File
- Document Server

**1** Click **[Send Options]**.

The **[Send Options]** window appears.

## 2 Specify the options you want to use.

---

To send a fax document at a specific time

---

- 1 Select the **[Sending at specific time]** check box, and then specify a transmission time.
- 2 Click **[Send]**.

---

To print a Sender Stamp

---

- 1 Select the **[Print Fax Header]** check box.
- 2 Click **[Send]**.

---

To attach a cover sheet

---

- 1 Select the **[Attach a Cover Sheet]** check box to attach a cover sheet to the document you are sending.

### Note

- Click **[Edit Cover Sheet]** to edit the cover sheet. See p.121 "Editing Fax Cover Sheets".
- Click **[Send]**.

---

To specify two-sided printing

---

- 1 Select the **[2 sided printing]** check box.
- 2 Click **[Print]**.

---

To display preview

---

Selecting the **[Preview]** check box allows you to check how the fax document will be output at the destination.

- 1 Select the **[Preview]** check box.
- 2 Click **[Print]** or **[Send & Print]**.

The **[Preview]** window appears.

- 3 Click **[Next]** or **[Previous]** to check the image.

### Note

- To close the **[Preview]** window, click **[Cancel]**.
- To print the preview image, click **[Print]**.

---

Saving as Files

---

You can save the fax document in TIFF format.

- 1 Select the **[Save as file]** check box.
- 2 Click **[Save to...]**.
- 3 Select a folder on the folder tree.
- 4 Select a method of file naming.

### Note

- To enter a file name manually, select the **[Specify file name when saving]** check box. To have the program name the file, select the **[Automatically create a new file]** check box.

- 5 Click **[OK]**.
- 6 Click **[Save]** or **[Send & Save]**.

### Note

- If you select **[Automatically create a new file]**, the image file is assigned a name and saved under the specified folder.
- The file name will be RicH-HMMSS.tif (HH: hours, MM: minutes, SS: seconds).

- 7 Enter a file name.

### Note

- You can also change the folder in this step.

- 8 Click **[Save]**.

The image file is saved in the specified folder.

---

To store the fax document on the Document Server

---

- 1 Select the **[Send to Document Server]** check box, and then enter a user name, file name, and password.

 **Note**

- If **[Hard Disk Unit]** is not selected in **[Accessories]** under **[LAN-Fax Driver properties]**, you cannot select for **[Document Server]**.

- 2 Click **[Send]**.

 **Checking transmission using LAN-Fax Driver**

From “SmartDeviceMonitor for Admin”, “SmartDeviceMonitor for Client”, or Web Image Monitor, you can check information on files sent using LAN-Fax Driver.

Also, you can save the content of the communication management report in a personal computer as a CSV file using **[Fax Communication Management Report Acquisition]** in “SmartDeviceMonitor for Admin”.

 **Reference**

See the relevant Help for details.

 **Note**

- When data is transmitted from the LAN-Fax Driver via the “SmartDeviceMonitor for Client” port, the “Data transfer completed” message appears on the computer’s display, so you can easily ascertain the communication progress. However, if the volume of communication data from the LAN-Fax to this machine increases, the message may appear during the operation, due to the differences in memory capacity between this machine and “SmartDeviceMonitor for Client”. For more accurate fax transmission results, use “Communication Result Report”. See p.81 “Communication Result Report (Memory Transmission)”.

---

**Confirming Transmission Results by E-mail**

---

After you are communicating the LAN-Fax mode, this function transmits the communication results with the computer by e-mail.

When you have done **[Send]** or **[Send Print]** using the LAN-Fax, and when the communication has been successful from the computer to this machine, it transmits an e-mail of the transmission result. See p.81 “Communication Result Report (Memory Transmission)”.

In addition, in case of communication error from the computer to this machine, or in case of printing, the LAN-Fax Result E-mail Report is transmitted.

 **Note**

- If there be any insufficient configuration in the e-mail menu on this machine, or if "Auto Specify Sender Name" is set to "Off", the LAN-Fax result notification e-mail will not be transmitted, and the LAN-Fax Result Report is printed out. See "Setting File Transfer", *Network Guide* for the e-mail settings, and see p.118 "LAN-Fax Result Report" for the LAN-Fax Result Report.

- 1** Click the **[E-mail Settings]** tab.
- 2** Select the **[Notify]** check box under **[E-mail TX results]**.
- 3** Enter the destination.

---

When entering the e-mail address directly

---

- 1** Click the **[Specify destinations]** radio button.
  - 2** Enter the e-mail address in the **[Specify destinations]** field.
- 

When entering the machine's programmed address

---

- 1** Click the **[Device Address]** radio button.
- 2** Enter the machine's programmed address in the **[Device Address]** field.

 **Note**

- This field is unavailable when the **[Specify destinations]** is selected, and you cannot enter in the text box.

- 4** Click **[Send]**.

## LAN-Fax Result Report

In case of being set at the LAN-Fax result e-mail report, if there be any insufficient configuration in the e-mail menu on this machine, or if "Auto Specify Sender Name" is set to "Off", the LAN-Fax result notification e-mail will not be transmitted, and the LAN-Fax Result Report is printed out. If the "LAN-Fax Result E-mail Report" of "Sender Settings" in "Transmission Mode" has not been set at "Yes", the LAN-Fax Result Report is printed out.

### Note

- Whether or not the LAN-Fax Result Report is printed out, can be configured at "User Parameters". See p.166 "User Parameters" (Switch 20, bit 0).
- When executing [**Send**] or [**Send Print**] with the LAN-Fax Driver, and when the E-mail TX Result Report has not been arrived, the Result Report is printed out. See p.81 "Communication Result Report (Memory Transmission)"

## Printing and Saving

You can print documents created using Windows applications.

You can also save documents in TIF format.

Open the application document you want to print or create a new document, and then perform the following procedure.

For details, see Help.

### Note

- You can select the time delay when problems such as paper running-out or paper jams are resolved. See p.166 "User Parameters" (switch 20, bit 2/3/4/5).

**1** On the [**File**] menu, click [**Print...**].

**2** Select [**LAN-Fax M6**] in [**Printer Name**], and then click [**OK**].

The [**LAN-Fax**] dialog box appears.

### Note

- The setting method may differ depending on the application you are using. In all cases, select [**LAN-Fax M6**] for the printer.

## Printing

**1** Click [**Print**] or [**Send & Print**].

### Note

- You can save the fax image in a file. See p.115 "Saving as Files".

## Editing Address Book

You can program and edit destinations in the address list using the Address Book.

For details, see Help.

**1** On the [**Start**] menu, point to [**Programs**], [**LAN-Fax Utilities**], and then click [**Address Book**].

The Address Book display appears.

### Note

- If LAN-Fax Driver has already started up, click [**Edit Address Book**].

**2** Click [**New/Browse...**], and then select the CSV file containing the address list to be edited.



### 3 Edit an existing destination or program a new one.

#### Note

- You can use files created in CSV format, as Address Book data. For this purpose, create CSV files that conform to a certain format. For more information, see Help.
- To program the contents of the Address Book of this machine to the destination list, select the **[Device Address]** check box, then enter the destination key's registration number in the **[Device Address]** field.

---

#### Programming new destinations

---

#### 1 Enter the destination and name.

##### Note

- You can enter the name, company name, department name, fax number, e-mail address, and IP-Fax address. The name and destination (Fax Number, E-mail Address or IP-Fax Address) cannot be omitted.
- For **[Line:]** under **[Fax number:]**, select the appropriate line type; G3, G3-2, G3-3, G3 Dir. Auto, G3 PABX Auto, or PABX.
- For **[Protocol:]** under **[IP-Fax address:]**, select **[H.323]** or **[SIP]**.

#### 2 Click **[Add]**.

The destination is added to the destination list.

---

#### Editing programmed destinations

---

#### 1 Select the destination you want to edit in the list.

The destination should appear in gray.

#### 2 Edit the data.

#### 3 Click **[Update]**.

---

#### Deleting programmed destinations

---

#### 1 Select the destination you want to edit in the list.

The destination should appear in gray.

#### 2 Click **[Delete]**.

#### 3 Click **[Yes]**.

#### 4 Click **[Close]**.

#### 5 If you made changes to a destination, a confirmation message appears. To save the changes, click **[Yes]**.

If you do not want to save the changes and want to quit editing, click **[No]**.

To return to the editing display, click **[Cancel]**.

##### Note

- The confirmation dialog box does not appear when you have not made any changes after starting Address Book.

### Using the machine's Address Book data in the destination list of the LAN-Fax

You can save information about fax destinations registered to this machine in a personal computer as a CSV file using "Address Information Management" in "SmartDeviceMonitor for Admin". Saved CSV files can be inserted into the destination table of the LAN-Fax Driver by selecting **[New/Reference]** in Destination Table Editing Tool. Save the file again for the LAN-Fax Driver.

#### Reference

For details, see "SmartDeviceMonitor for Admin" Help.

#### Note

- When destinations registered in groups by this machine are inserted into Destination Table Editing Tool, each person's destination is determined according to the following order of priority (check before inserting and changing the order of priority, if necessary): IP-Fax destination → Fax number → Mail address
- Depending on the machine type, you may not be able to use the machine when it is updating the Address Book using CSV files (retrieved using SmartDeviceMonitor for Admin) that contain user codes.

### Managing facsimile functions using SmartDeviceMonitor for Admin

You can check information about this machine's fax functions using a computer and save files on a computer using SmartDeviceMonitor for Admin.

You can use SmartDeviceMonitor for Admin to do the following:

- Check information about fax destinations registered to this machine using "Address Information Management".
- Save information about fax destinations registered to this machine in a personal computer as a CSV file using "Address Information Management". Saved CSV files can be inserted into the destination list of the LAN-Fax Driver using the Destination List Editing Tool.

#### Note

- For details about SmartDeviceMonitor for Admin and its installation, see *Printer Reference*.
- For details, see *Network Guide* and SmartDeviceMonitor for Admin Help.

## Editing Fax Cover Sheets

LAN-Fax Cover Sheet Editor allows you to edit the format for fax cover sheets. It is necessary to create a cover sheet file before attaching a cover sheet to fax messages using LAN-Fax Driver.

### Creating a cover sheet

Use the following procedure to create a fax cover sheet.

You can edit the items below using LAN-Fax Cover Sheet Editor.

- Company name as destination info.
- Department name as destination info.
- Person name as destination info.
- Title of address as destination info.
- Company name as sender info.
- Department name as sender info.
- Person name as sender info.
- Telephone number as sender info.
- Fax number as sender info.
- Date
- Message

#### Note

- Cover sheet data is stored in its own format (using “fcp” as its extension)

- 1** On the [Start] menu, point to [Programs], [LAN-Fax Utilities], and then click [LAN-Fax Cover Sheet Editor].

The dialog box of LAN-Fax Cover Sheet Editor appears.

- 2** Edit the cover sheet.

#### Note

- For details about operations, see Help.

- 3** Click [Save as...] on the [File] menu.

- 4** Select a folder, and then enter a file name.

- 5** Click [Save].

### Attaching a created cover sheet

Use the following procedure to attach a created cover sheet file to a fax message.

- 1** On the [File] menu, click [Print...].

- 2** Select “LAN-Fax M6” in “Printer Name”, and then click [OK].

The [LAN-Fax] dialog box appears.

- 3** Click [Edit Cover Sheet].

The [Edit Cover Sheet] dialog box appears.

- 4** Select a cover sheet file from the drop-down list or after clicking [Browse...] in [Select Cover Sheet].

#### Note

- The selection made in [Select Cover Sheet] is not canceled unless you select another file. If you want to change only destination information, skip this step and proceed to step **5**.

- 5** Select the type of information from [To:].

#### Note

- You can select [Use Address Book], [To Whom It May Concern], [Edit Names], or [None]. Selecting [Edit Names] allows you to enter company, department, and person names.

- 6** To print the date, select the [With a Date] check box.

**7** Enter the sender information.

 **Note**

- You can enter company, department, and person names, and telephone and fax numbers.
- To add a message, select the **[With a Message]** check box, and then enter a message.

**8** Click **[OK]**.

**9** Specify a destination.

**10** Click the **[Send Options]** tab and then select the **[Attach a Cover Sheet]** check box.

**11** Click **[Send]**.

---

## LAN-Fax Operation Messages

---

Message	Causes and Solutions
Cannot access the printer. Click [retry] to send the data again.	Check the network connection. Check that the power is turned on.
The number of entries in Destinations exceed the limits. Up to 500 entries can be entered.	The number of destinations specified exceeds the maximum possible. The maximum number of destinations that can be specified at one time is 500.
"LAN-Fax" has already been launched. Cannot launch it again.	The <b>[LAN-Fax]</b> dialog box is already open. Quit LAN-Fax once, and then start it up again.
Failed to allocate memory.	Available memory on the computer is insufficient. Quit applications currently not in use.

# Viewing Fax Information Using a Web Browser

You can view received fax messages and their lists or print these messages using a Web Image Monitor on a network computer.

## Note

- You need to select "Store" as the "Reception File Setting" in the Facsimile Features menu. See p.193 "Storing or Printing Received Documents".
- You can also check and manage the documents using DeskTop-Binder Lite. See p.139 "Managing Documents Saved in the Document Server from a Computer".

## Reference

"Using Web Image Monitor", *Network Guide*

## Viewing, Printing, and Deleting Received Fax Messages Using a Web Image Monitor

Use the following procedure to view and/or print received fax messages using a Web Image Monitor.

### Viewing received fax messages using a Web browser

- 1** Start a Web browser.
- 2** Enter the machine's IP address in the [Address] field.
- 3** Click [Fax Received File] in the left pane.

### With a user code (stored reception file) programmed

- 1** If you have programmed a user code, enter the code, and then press [OK].

A list of the received fax messages appears.

## Note

- If the programmed user code has been deleted using the Address Book Management function under System Settings, a message indicating incorrect user code entry appears. If this is the case, reprogram a user code. See p.195 "Setting a User for Viewing Received and Stored Documents".

- 4** Click the Property icon of the desired fax message.

## Note

- To view a list of the fax messages, select the thumbnail display, detail display, or icon display. Click [Thumbnails], [Details], or [Icons].

- 5** View the content of the fax message.

## Note

- To enlarge the preview image, click [Enlarge Image]. Enlargement cannot be performed without Acrobat Reader installed. For more information, see Help on the Web Image Monitor.

**6** To download the received fax message, click **[PDF]** or **[Multi-page TIFF]**.

Clicking **[PDF]** causes Acrobat Reader to be started and the message to be displayed.

Clicking **[Multi-page TIFF]** causes a downloading confirmation window to appear.

 **Note**

- The method for downloading differs depending on the selected format. For more information, see Help on the Web Image Monitor.

---

**Printing fax information using a Web browser**

---

**6****1** Start a Web browser.**2** Enter the machine's IP address in the **[Address]** field.**3** Click **[Fax Received File]** in the left pane.

The list of received fax messages appears.

**4** Click and select the check box beside the fax message to be printed. **Note**

- To view a list of the fax messages, select the thumbnail display, detail display, or icon display. Click **[Thumbnails]**, **[Details]**, or **[Icons]**.

**5** Click **[Print]**.**6** Click **[Start Print]**. **Note**

- To cancel printing, press **[Cancel]** before clicking **[Start Print]**.

- You can change the printing order of selected multiple messages. You can also have messages printed on both sides of paper. For more information, see Help on the Web Image Monitor.

**7** Click **[OK]**.

The display returns to that of step **4**.

---

**Deleting fax information using a Web browser**

---

**1** Start a Web browser.**2** Enter the machine's IP address in the **[Address]** field.**3** Click **[Fax Received File]** in the left pane.

The list of received fax messages appears.

**4** Click and check the check box beside the fax message to be deleted. **Note**

- To view a list of the fax messages, select the thumbnail display, detail display, or icon display. Click **[Thumbnails]**, **[Details]**, or **[Icons]**.

**5** Click **[Delete]**.**6** Click **[Delete File]**. **Note**

- To cancel deletion, press **[Cancel]** before clicking **[Delete File]**.
- After selecting multiple messages, you can also cancel deletion of some of the selected messages. For more information, see Help on the Web Image Monitor.

**7** Click **[OK]**.

The display returns to that of step **4**.

## Programming Destination Information from Web Browser

If the receiving machine is compliant with T.37 full mode Internet Fax, you can program the receiver's properties from Web Image Monitor. You can program the following properties:

- Compression type
- Paper size
- Character size

### Note

- For the detailed description, see Help for Web Image Monitor.
- When a receiver that is programmed as full mode in the Address Book returns a Reception Confirmation e-mail, the contents of the newly received e-mail overwrite the existing information.

### Reference

p.55 "T.37 Full Mode", *Facsimile Reference <Basic Features>*

- 1** Start the Web browser.
- 2** Enter the IP address of the machine you want to monitor after "http://" in the address field.  
The top screen is displayed.
- 3** Click [Login], and then enter the Administrator's name and password.
- 4** Click [Address Book] in the left pane.  
The Address Book is displayed.
- 5** Set the Internet Fax data format.

To edit machine properties already programmed

- 1** Click the radio button to the left of the machine you want to modify, and then click [Change].

The [Edit User] page appears.

- 2** Set the properties for Internet Fax data format other than the mode selection.

### Note

- If you change the mode to "Simple", you cannot set machine properties.

- 3** Click [OK] at the upper-right of the screen.

The Address Book is displayed.

### Note

- To cancel the setting, click [Cancel] in the upper-right of the screen.

To add new receiver

- 1** Click [Add].  
The [Add User] page appears.
- 2** Check that [User] is selected in the dropdown menu.
- 3** Enter the registration number, name, and e-mail address, then set the necessary properties.

### Note

- You can set the Internet Fax data format after entering the e-mail address.

- 4** Click [Full] under [Internet Fax data format:], and set the properties according to the receiver's properties.

 **Note**

- If you change the mode to “Simple”, you cannot set machine properties.

**5** Click **[OK]** in the upper-right of the screen.

The Address Book is displayed.

 **Note**

- To cancel the setting, click **[Cancel]** in the upper-right of the screen.

**6** Close the Web browser.



# Delivering Files Received by Fax

*ScanRouter EX Professional (sold separately) is also required as a delivery server. DeskTopBinder Lite or DeskTopBinder Professional (sold separately) software must be installed on your computer.*

Messages received by the machine can be viewed on or downloaded to a computer with the network delivery server, ScanRouter EX Professional. This is a useful function, enabling you to view and store messages on your computer without printing them.

Using the delivery server, you can eliminate the task of retrieving and delivering messages.

## ◆ Functions

Delivery server provides the following functions:

- Use the delivery server to associate incoming messages (Confidential ID, SUB Code, Own Name, and Own Fax Number) with receivers, so messages are delivered to the intended receivers.
- You can select the delivery method for incoming messages: "Save in the delivery server inbox", "Send as an e-mail attachment", or "Save in the designated PC folder". Incoming messages with no Confidential ID, ID Override Confidential Transmission, SUB Code, Own Name, or Own Fax Number are saved in the delivery server inbox. You can also set so that the received messages are stored in the specified delivery server inbox according to the used line for reception.

- You can check or download received messages stored in the delivery server inbox using DeskTopBinder Professional Lite or DeskTopBinder Professional.

## ● Limitation

- Confidential messages are also forwarded to the delivery server.

## ✎ Note

- To view or download messages stored in the delivery server inbox, you need to install the separately sold DeskTopBinder on your computer.
- To send received messages to your computer as e-mail attachments, you need to have a ScanRouter EX Professional-compatible e-mail program on your computer.
- To create a network using the delivery server, settings must be specified in the User Tools of the machine. Settings must also be specified on the delivery server. See "File Transfer", *General Settings Guide*.
- See ScanRouter EX Professional Help or instructions for more information on the delivery server (ScanRouter EX Professional).
- For information about DeskTopBinder, see DeskTopBinder's manual and Help.



# 7. Simplifying the Operation

## Programs

If you regularly send messages to a particular destination or transmit using the same functions, you can save repetitive keypad operations by registering this information in a Keystroke Program.

---

### Registering and Changing Keystroke Programs

---

Keystroke Programs can be recalled by just pressing a Quick Dial key. The following procedure can be used to program a new Keystroke Program or overwrite an old one.

You can register the following items in Keystroke Programs:

- Memory Transmission, Internet Fax Transmission, Immediate Transmission, destinations (up to 500 numbers), character size, original type, line selection (only when a destination is specified using number keys), Complete Stamp, time-specified transmission, confidential transmission, automatic thickness, manual thickness, scan size, different-size original, file attachment, specification of two-page spread original, delivery-limit-specified transmission, polling transmission, polling reception, relay request transmission, two-sided original transmission, text input, reception confirmation settings, BCC transmission settings, protocol selection, each optional setting's function.
- Program name (up to 20 characters)

#### **Limitation**

- You cannot register the following using program No.1:
  - Any destination
  - Store File
  - Polling Transmission
  - Sender Settings
  - Specifying a stored file
  - Enter Subject of E-mail Options

#### **Note**

- The maximum number of programs you can register is 100.
- Use the same procedure to register and change programs. In step **5**, select the program number you want to change.
- The method of registering or changing programs for the copy function is different from that of the fax function.

#### **1** Prepare for registering the program.

##### **Note**

- The procedure for programming differs depending on the items you want to register.
- Press the **[Clear Modes]** key to cancel programming.

---

Example of registering a program using Send Later with the fax number "0123456789"

- 1** Press **[0], [1], [2], [3], [4], [5], [6], [7], [8], [9]** using the number keys.

- 2 Perform the Send Later setting till the procedure of pressing [OK] to return to the standby mode.

**Reference**

p.3 "Sending at a Specific Time (Send Later)"

- 2 Make sure that the machine is in facsimile mode and the standby display is shown.

**Note**

- If the standby display is not shown, press the [Facsimile] key.

- 3 Press the [Program] key.

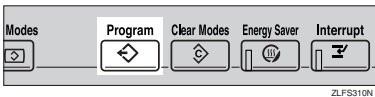

- 4 Make sure that [Register] is selected.

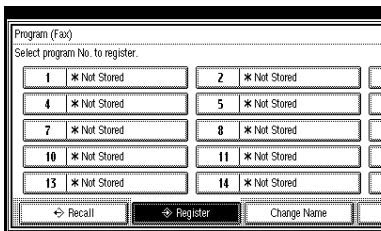

- 5 Select a program number in which "\*Not Stored" is shown.

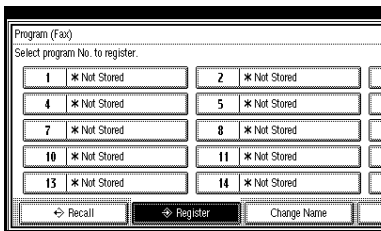

**Note**

- If you make a mistake, press [Cancel] and select a program number again.

- If you change a Keystroke Program, press [Register] after pressing the program number you want to change. If you make a mistake, press [Do not Register] and return to step 5.

- 6 Enter the program name, and then press [OK].

The standby display appears.

**Note**

- If you make a mistake, press [Backspace] or [Delete All], and then try again.
- You should register the program name.
- To cancel a programmed program, press [Cancel]. The display returns to that of step 5.

**Reference**

"Entering Text", *General Settings Guide*

**Registering a priority function using a program**

You can select whether or not the function registered in program No. 1 will be set after the power is turned on or the [Clear Modes] key is pressed.

After registering a function in program No. 1, select [Program No.1] for [Change Initial Mode] on the Facsimile Features menu. See p.144 "General Settings/Adjustment".

**Limitation**

- You cannot register the following using program No.1:
  - Any destination
  - Store File
  - Polling Transmission
  - Sender Settings
  - Specifying a stored file
  - Enter Subject of E-mail Options

## Changing a program name

- 1 Make sure that the machine is in facsimile mode and the standby display is shown.

**Note**

- If the standby display is not shown, press the **[Facsimile]** key.

- 2 Press the **[Program]** key.

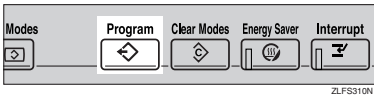

- 3 Press **[Change Name]**.

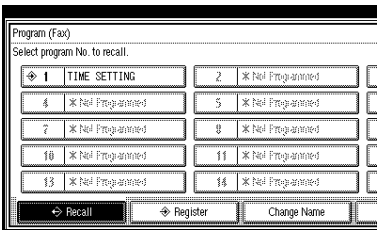

- 4 Select the program number of the name you want to change.

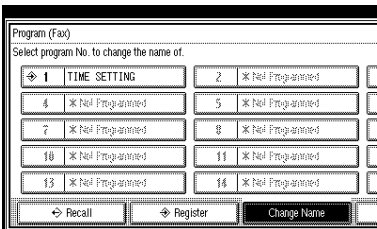

- 5 Enter a new program name, and then press **[OK]**.

**Note**

- Press **[Cancel]** to cancel the change, and proceed to step 6.

- 6 Press **[Exit]**.

The standby display appears.

## Deleting a Program

- 1 Make sure that the machine is in facsimile mode and the standby display is shown.

**Note**

- If the standby display is not shown, press the **[Facsimile]** key.

- 2 Press the **[Program]** key.

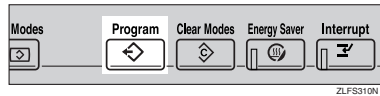

- 3 Press **[Delete]**.

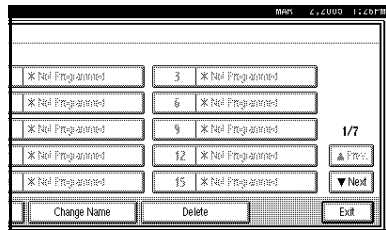

- 4 Select the program number you want to delete.

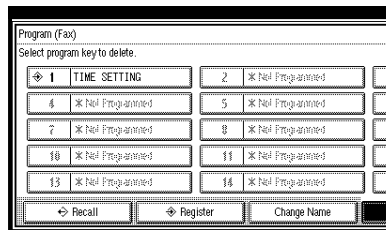

- 5 Press **[Yes]**.

**Note**

- Press **[No]** not to delete the program. The display returns to that of step 3.

- 6 Press **[Exit]**.

The standby display appears.

## Using a Program

**Note**

- Using the program causes the previous settings to be cleared.
- If you have no programmed destinations or scan settings as programs, select the program number, and then enter the fax number of the destination and select the scan settings you require.

**1** Make sure that the machine is in facsimile mode and the standby display is shown.

**Note**

- If the standby display is not shown, press the **[Facsimile]** key.

**2** Place the original.

**3** Press the **[Program]** key.

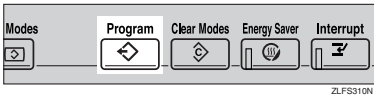

**4** Confirm that **[Recall]** is selected, and press the registered program No.

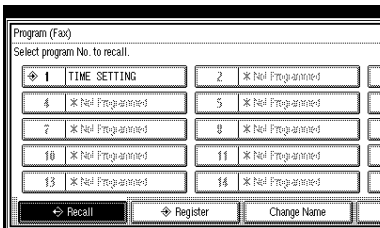

The standby display appears.

Then, the programmed fax number is shown. Transmission Mode is selected.

**5** Press the **[Start]** key.

The fax number and specified time are shown on the display, and the machine starts to scan the original.

Transmission starts at the specified time.

# Using the Document Server

The Document Server can store documents from various applications.

The documents that are stored using the facsimile function are available to transmit by facsimile.

Storing in the Document Server enables the following:

- Once stored, a document can be sent out as many times as you want, just by selecting it.
- Storing a document does not use facsimile memory.

You can send and print multiple stored documents as a single document, and also send them with scanned originals at the same time. Follow the instructions under **[Select Stored File]** in **[Sub TX Mode]** when sending or printing stored documents. See p.67 "Sending a Stored File".



## Reference

"What You Can Do with This Machine", *General Settings Guide*



## Important

- ❑ Data stored in the machine might be lost if some kind of failure occurs. The manufacturer shall not be responsible for any damage that might result from the loss of data.



## Note

- ❑ You can specify whether or not the machine automatically deletes documents from the Document Server after a certain number of days. The delete function is pre-configured with the software and automatically deletes any stored document that is more than three days (72 hours) old. You can change the setting with "Auto Delete File" under "System Settings". See "Administrator Tools — Auto Delete File", *General Settings Guide*.
- ❑ You can store approximately 9,000 pages (ITU-T No.4 chart) in the Document Server, using the copy, facsimile, printer, and scanner functions.
- ❑ The Document Server has a memory capacity of 2,000 documents maximum.
- ❑ You can store up to 1,000 pages per document.
- ❑ You cannot check received and stored documents through the Document Server. See p.34 "Printing Received and Stored Documents".
- ❑ Stored documents are not deleted even when there is a power failure, or the main power switch is turned off.

## Storing a Document

You can store and send a document at the same time. You can also just store a document.

### ❖ File names

Scanned documents are automatically assigned names like "FAX0001" or "FAX0002". See p.135 "Setting a file name".

### ❖ User Names

You can set this function if necessary to know who and what departments stored documents in the machine. See p.135 "Programming a user name".

### ❖ Password

You can set this function so as not to send to unspecified people. See p.135 "Setting a password".

### 📎 Note

- You can change file names and user names. See p.136 "Changing Information of Stored Documents".

**1** Make sure that the machine is in facsimile mode and the standby display is shown.

If the standby display is not shown, press the **[Facsimile]** key.

**2** Place the original, and then select the scan settings you require.

### 🔍 Reference

p.13 "Placing Originals", *Facsimile Reference <Basic Features>*

**3** Press **[Stored File]**.

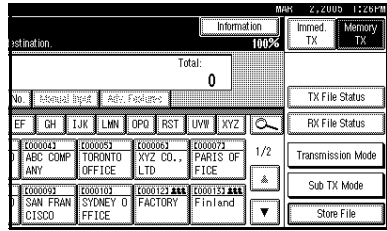

**4** Select **[Store & Transmit]** or **[Store only]**.

Select **[Store & Transmit]** to send documents after they are stored.

Select **[Store only]** to store documents.

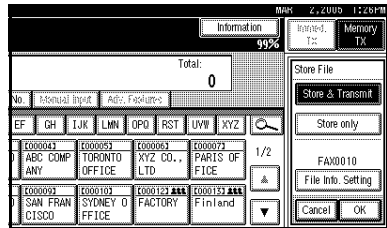

### 📎 Note

- When **[Store only]** is selected, "\*\*\*\*\*" is shown.

**5** Press **[File Info. Setting]**, and then set the user name, file name, and password as necessary.

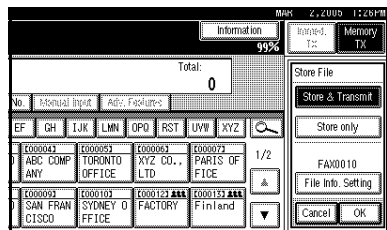



**Note**

- If you are not setting a user name, file name, or password, proceed to step 6.
- You cannot change multiple documents at once.

## Programming a user name

**Note**

- Set a user name from those programmed in the user code. User code is programmed in System Settings. See “Registering a New User Code”, *General Settings Guide*.

**1 Press [User Name].**

The screenshot shows the 'File Information' screen with the following data:

No.	Manual Input	Adv. Features
0000043	0000053	0000063 0000073
ABC COMP	TORONTO OFFICE	XYZ CO., LTD. PARTS OF FICE
ANY		
0000093	0000103	0000113 0000123
SAN FRAN CISCO	SYDNEY OFFICE	FACTORY Finland

The 'File Information' panel on the right shows: User Name: FAX0010, File Name: None, Password: None.

**2 Press the user name to be programmed, and then press [OK].**

The 'Change User Name' dialog box shows a grid of user names and titles:

Freq.	AB	CD	EF	GH	IJK	LMN
Donald	LEGAL DIV	NEWYORK BRANCH	PARTS			
Alex	Allen	ABC_NET	Dord			
Jones	Lucy	LONDON OFFICE	New York			
ABC COMPANY	TORONTO OFFICE	XYZ CO., LTD	PARTS			

The 'Switch Title' button is at the bottom.

**Note**

- Press the title key to switch between titles.

- To set a non-programmed user name, press [**Non-programmed Name**], and then enter the name. User names entered by pressing [**Non-programmed Name**] are not programmed into the user code.

**Reference**

“Entering Text”, *General Settings Guide*

**3 Press [OK].**

## Setting a file name

**1 Press [File Name].**

The screenshot shows the 'File Information' screen with the following data:

No.	Manual Input	Adv. Features
0000043	0000053	0000063 0000073
ABC COMP	TORONTO OFFICE	XYZ CO., LTD. PARTS OF FICE
ANY		
0000093	0000103	0000113 0000123
SAN FRAN CISCO	SYDNEY OFFICE	FACTORY Finland

The 'File Information' panel on the right shows: User Name: FAX0010, File Name: None, Password: None.

**2 Enter the file name, and then press [OK].****Reference**

“Entering Text”, *General Settings Guide*

**3 Press [OK].**

## Setting a password

**1 Press [Password].**

The screenshot shows the 'File Information' screen with the following data:

No.	Manual Input	Adv. Features
0000043	0000053	0000063 0000073
ABC COMP	TORONTO OFFICE	XYZ CO., LTD. PARTS OF FICE
ANY		
0000093	0000103	0000113 0000123
SAN FRAN CISCO	SYDNEY OFFICE	FACTORY Finland

The 'File Information' panel on the right shows: User Name: FAX0010, File Name: None, Password: None.

7

- Enter a password using the number keys, and then press [#].

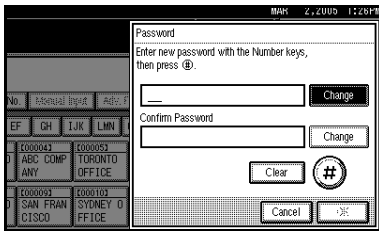

**Note**

- If you make a mistake, press [Clear] or the [Clear/Stop] key before pressing [OK], and then reenter your password.
- You can enter up to four to eight digits.

- Enter the password again, and then press [#].

- Press [OK].

**Note**

- Press [Change] to enter a different password.

- Press [OK].

- Press [OK].

- If you have selected [Store & Transmit], specify the receiver.

**Note**

- If you have selected [Store only], proceed to step 8.

- Press the [Start] key.

## Changing Information of Stored Documents

You can change the file name, user name, and password of stored documents.

To change a stored document, delete the document you no longer need, and then reprogram the new document. See p.138 "Deleting a Stored Document".

**Note**

- You can program one of the Quick Operation keys with operations for this function. Using the key allows you to omit steps 1. See p.144 "General Settings/Adjustment".

- Press [Sub TX Mode].

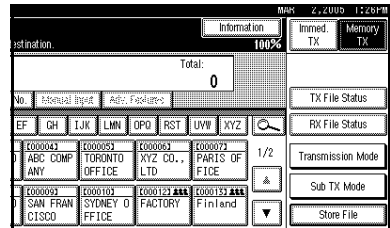

- Select [Select Stored File].

- Select [Manage / Delete File], and then press the document to be changed.

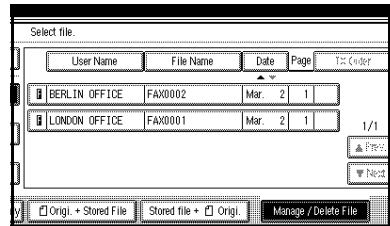

- 4** If you select a document for which a password is set, enter the password, and then press [OK].

When a selected file does not have a password, proceed to step **5**.

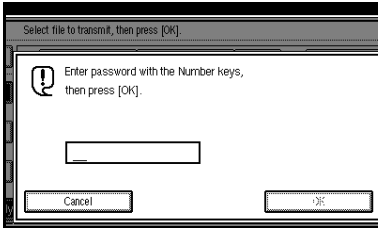

- 5** Change the desired information of the stored document.

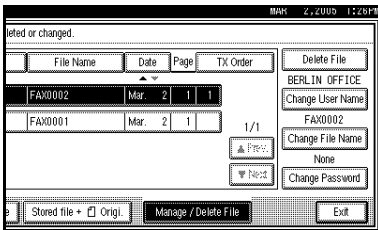

### Changing a user name

- 1** Press [Change User Name].
- 2** Press [Clear].

The user name is deleted.



- 3** Enter the new user name, and then press [OK].

#### Note

- Press the title keys to switch between titles.

- To set a non-programmed user name, press [Non-programmed Name], and then enter the name.
- User names entered by pressing [Non-programmed Name] are not programmed into the user code.

#### Reference

“Entering Text”, *General Settings Guide*

### Changing the file name

- 1** Press [Change File Name].
- 2** Press [Backspace] or [Delete All], and then re-enter the file name.

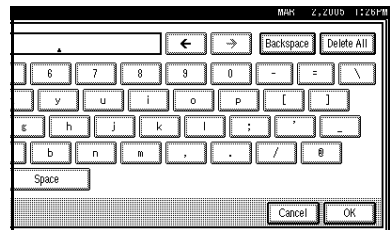

#### Reference

“Entering Text” *General Settings Guide*

- 3** Press [OK].

### Changing the password

- 1** Press [Change Password].
- 2** Press upper [Change].

- Enter a new password using the number keys, and then press [#].

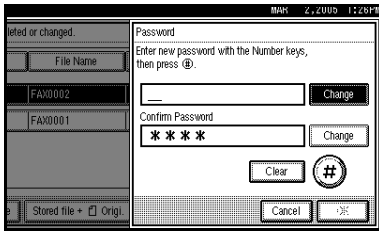

- Press lower [Change].
- Enter the password again, and then press [#].
- Press [OK].

- Press [Exit].

- Press [OK].

The standby display appears.

## Deleting a Stored Document

Use this function to delete stored documents.

### Note

- You can program one of the Quick Operation keys with operations for this function. Using the key allows you to omit steps 1. See p.144 "General Settings/Adjustment".

- Press [Sub TX Mode].

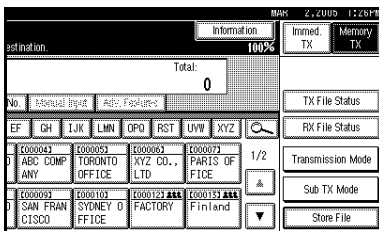

- Press [Select Stored File].

- Press [Manage / Delete File].

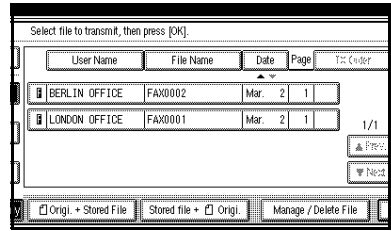

- Select the document you want to delete.

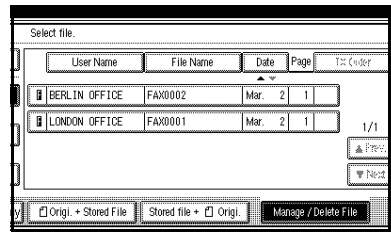

### Note

- You can also delete multiple documents at once.

With a programmed password

- Enter a password using the number keys, and then press [OK].

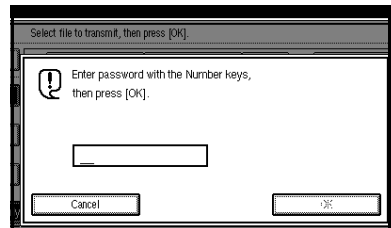

- Press [Delete File].

- Press [Delete].

### Note

- If you do not want to delete the document, press [Do not Delete].

- Press [Exit].

**8** Press [OK].

The standby display appears.

---

## Managing Documents Saved in the Document Server from a Computer

---



---

### Using DeskTopBinder

---

Fax documents saved in the Document Server can be viewed and controlled from a network computer with DeskTopBinder installed.

The following operations are available using the computer:

- Displaying documents (Easy Viewer)
- Displaying document properties (Properties)
- Deleting documents (Delete)
- Copying documents to a computer (Copy)
- Printing documents (Print from Document Server)
- Exporting documents as files (Export Document)
- Importing documents into a computer (Import Document)

For more information, see DeskTopBinder's manual and Help.

### Limitation

- If you use a link in Auto Document Link the versions earlier than DeskTopBinder Lite or Professional version 4.0.0.0., set the SNTP Server Address as "0.0.0.0" on Web Image Monitor. If the address is not set correctly, documents cannot be properly imported. For details about import settings, see Help for Web Image Monitor.

### Note

- When you send a document using Fax, if the registration number in the Address Book registered to the device is specified, you can send the document to a fax number only. Documents cannot be sent even if e-mail and IP-Fax addresses are already registered.

---

### Using a Web browser

---

Fax documents saved in the Document Server can be viewed using a Web Image Monitor on a network computer. These fax documents can also be downloaded to the computer's hard disk. See p.123 "Viewing Fax Information Using a Web Browser".



# 8. Facsimile Features

## Function List

The User Tools allow you to program your identification, store frequently used numbers and settings, and customize default settings to meet your needs.

The User Tools are grouped by functions so that you can quickly and easily find the desired User Tool.

### ◆ General Settings/Adjustment

Description	Reference
<p data-bbox="162 544 565 619">Default Transmission Mode and scan settings. When the power is turned on, settings specified here are selected:</p> <ul data-bbox="162 630 565 1235" style="list-style-type: none"><li data-bbox="162 630 565 662">• Memory / Immed. Transmission Switch</li><li data-bbox="162 670 565 702">• Text Size Priority</li><li data-bbox="162 710 565 742">• Original Type Priority</li><li data-bbox="162 750 565 782">• Auto Image Density</li><li data-bbox="162 790 565 821">• Adjust Scan Density</li><li data-bbox="162 829 565 861">• Select Title</li><li data-bbox="162 869 565 901">• Change Initial Mode</li><li data-bbox="162 909 565 941">• Adjust Sound Volume</li><li data-bbox="162 957 565 989">• Program Fax Information</li><li data-bbox="162 1021 565 1053">• Scan End Reset</li><li data-bbox="162 1061 565 1093">• TX Stamp Priority</li><li data-bbox="162 1101 565 1133">• Line Priority Setting</li><li data-bbox="162 1141 565 1173">• Program Economy Time</li><li data-bbox="162 1181 565 1212">• On Hook Mode Release Time</li><li data-bbox="162 1220 565 1244">• Quick Operation Key</li></ul>	<p data-bbox="576 544 984 571">p.144 "General Settings/Adjustment"</p> <p data-bbox="576 895 984 946">p.83 "Adjusting the Volume", <i>Facsimile Reference</i> &lt;Basic Features&gt;</p> <p data-bbox="576 959 984 1010">p.75 "Initial Settings and Adjustments", <i>Facsimile Reference</i> &lt;Basic Features&gt;</p>

◆ Reception Settings

Description	Reference
<p>Allows you to switch the following reception functions on or off:</p> <ul style="list-style-type: none"> <li>• Switch Reception Mode</li> <li>• Authorized RX</li> <li>• Forwarding</li> <li>• RX File Print Qty</li> <li>• 2 Sided Print</li> <li>• RX Reverse Printing</li> <li>• Paper Tray</li> <li>• Specify Tray for Lines</li> <li>• Checkered Mark</li> <li>• Center Mark</li> <li>• Print Reception Time</li> </ul>	<p>p.147 "Reception Settings"</p> <p>p.175 "Authorized RX (Authorized Reception)"</p> <p>p.175 "Forwarding"</p> <p>p.176 "Reception File Print Qty"</p> <p>p.97 "Two-Sided Printing"</p> <p>p.100 "Reverse Order Printing"</p> <p>p.177 "Paper Tray"</p> <p>p.105 "Specifying Tray for Lines"</p> <p>p.96 "Checkered Mark"</p> <p>p.96 "Center Mark"</p> <p>p.97 "Reception Time"</p>

◆ E-mail Settings

Description	Reference
<ul style="list-style-type: none"> <li>• Internet Fax Settings</li> <li>• Max. E-mail Size</li> <li>• SMTP RX File Delivery Settings</li> </ul>	<p>p.148 "E-mail Settings"</p>

◆ IP-Fax Settings

Description	Reference
<ul style="list-style-type: none"> <li>• Enable H.323</li> <li>• Enable SIP</li> <li>• H.323 Settings</li> <li>• SIP Settings</li> <li>• Program / Change / Delete Gateway</li> </ul>	<p>p.150 "IP-Fax Settings"</p>



## ◆ Administrator Tools

Description	Reference
<ul style="list-style-type: none"> <li>• Program / Change / Delete Standard Message</li> <li>• Store / Change / Delete Auto Document</li> <li>• Program / Change / Delete Scan Size</li> <li>• Print Journal</li> <li>• Transmission Page Count</li> <li>• Forwarding</li> <li>• Memory Lock RX</li> <li>• ECM</li> <li>• Parameter Setting</li> <li>• Program Special Sender</li> <li>• Box Setting</li> <li>• Transfer Report</li> <li>• Program Confidential ID</li> <li>• Program Polling ID</li> <li>• Program Memory Lock ID</li> <li>• Select Dial / Push Phone</li> <li>• Reception File Setting</li> <li>• Stored RX File User Setting</li> <li>• Menu Protection Settings</li> </ul>	p.155 "Administrator Setting"

## Displays

- Each menu appears in each tab.
- You can switch the display by pressing [**▲ Prev.**] or [**▼ Next**].
- The selected item is highlighted.
- When you have made all required settings, press [**OK**]. If [**OK**] is not pressed, the new settings might be canceled.
- Press [**Cancel**] to cancel the new settings. The previous display appears.

# Accessing User Tools (Facsimile Features)

Customize the facsimile settings according to the operations to be frequently performed.

**Note**

- The machine allows you to change the facsimile defaults in a mode that is not the facsimile mode. After changing the defaults, select facsimile mode again. This section describes the facsimile defaults that the machine allows you to customize.
- Customized facsimile defaults are kept until the defaults are changed again. The new settings are not cancelled by turning off the main power switch or the Operation switch or pressing the **[Clear Modes]** key.

**Reference**

For the items that can be changed using System Settings, see “User Tools (System Settings)”, *General Settings Guide*.

**1** Press the **[User Tools/Counter]** key.

The main menu display for default settings appears.

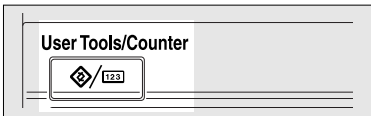

ZFLS110N

**2** Press **[Facsimile Features]**.

The menu display for facsimile default settings appears.

**3** Select the item that you want to change.

The corresponding setting display appears.

**Reference**

p.141 “Function List”

**4** Follow the displayed instructions to change the default, and then press **[OK]**.

**Note**

- If you make a mistake, press **[Cancel]**.

## Quitting Default Settings

**1** After changing the defaults, press **[Exit]** on the main menu display for default settings.

The standby display appears.

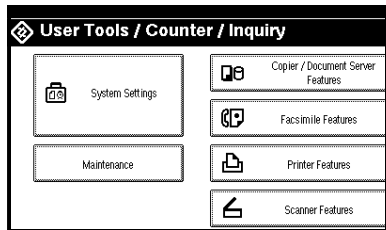

**Note**

- You can also press the **[User Tools/Counter]** key to quit the main menu display for default settings.

## General Settings/Adjustment

**Memory / Immed. Transmission Switch**  
Use this function to specify the Transmission Mode for document transmission.

- Memory Transmission
- Immediate Transmission

### ❖ Text Size Priority

Use this function to specify the character size of your originals for scanning.

- Standard
- Detail
- Super Fine (expansion memory required)

### ❖ Original Type Priority

Use this function to specify the type of originals for scanning.

- Text
- Text / Photo
- Photo

### ❖ Auto Image Density

Use this function to prioritize automatic Image Density for scanning your originals.

- On
- Off

### ❖ Adjust Scan Density

Use this function to specify the scan density of your originals.

### ❖ Select Title

Use this function for selecting the title to be shown on the destination list.

- Title 1
- Title 2
- Title 3

### ❖ Change Initial Mode

Use this function to select whether contents registered in program No.1 are to be used as the initial settings after the power is turned on or the **[Clear Modes]** key is pressed:

- Standard
- Program No.1

### Note

- You cannot select Program No.1 if program No.1 has not been programmed with priority functions.

### ❖ Adjust Sound Volume

Use this function to adjust the sound volume during On Hook Mode and Immediate Transmission.

See p.83 "Adjusting the Volume", *Facsimile Reference <Basic Features>*.

- Default ID TX
- At Transmission
- At Reception
- At Dialing
- At Printing

### ❖ Program Fax Information

See p.75 "Initial Settings and Adjustments", *Facsimile Reference <Basic Features>*.

- Fax Header
- Own Name
- Own Fax Number

### ❖ Scan End Reset

Use this function to return to the initial settings each time an original is scanned.

- On
- Off

### ❖ TX Stamp Priority

Use this function to press a TX stamp.

- On
- Off

◆ **Line Priority Setting**

Use this function to specify the line of usage.

 **Note**

- The display may differ depending on the line type you have.

◆ **Program Economy Time**

Use this function for specifying a time for transmission when call charges are low. See p.3 “Sending at a Specific Time (Send Later)”.

 **Limitation**

- You can program only one Economy Time.

 **Note**

- If you make a mistake, press **[Clear]** or the **[Clear/Stop]** key before pressing **[OK]**, and then try again.

◆ **On Hook Mode Release Time**

Use this function to specify a time to cancel On Hook mode after you transmit using On Hook dialing.

- 1 minute
- 3 minutes
- 5 minutes
- 10 minutes

◆ **Quick Operation Key**

Frequently used functions programmed as Quick Operation keys are shown on the menu immediately after the power is turned on. The Quick Operation keys can be programmed with the following functions:

- Journal
- TX Status Display (Transmission File Status)
- Print Confidential RX File (Print Confidential Reception)
- Print Memory Lock File

- Stored File
- Send Later
- Auto Document
- 2 Sided Original
- Closed Network
- Polling Transmission (Polling Transmission)
- Polling Reception (Polling Reception)
- Fax Header Print
- Label Insertion
- RX File Status (Reception File Status)
- Forwarding
- Transfer Request
- Switch RX Mode (Reception Mode Switch)
- Manual E-mail RX (when the Internet Fax is set to ON.)
- TX Status Report (Transmission Status Report)
- Sender Settings
- E-mail TX Results(E-mail Transmission Results)

Up to three functions can be programmed into a Quick Operation keys.

- 1 **Select Quick Operation Key you want to program.**
- 2 **Select the function you want to program in the Quick Operation Key .**

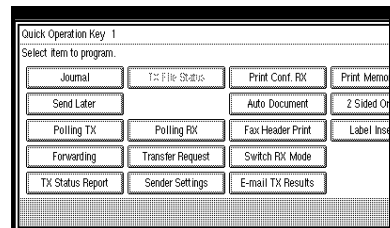

 **Note**

- Functions that appear dimmed have already been set.

---

## Reception Settings

---

❖ **Switch Reception Mode**

Specify the method for receiving fax messages.

- Manual Reception
- Auto Reception

❖ **Authorized RX (Authorized Reception)**

Specify whether or not unwanted fax messages are to be screened out.

- On
- Off

❖ **Forwarding**

Specify whether or not received fax messages are to be forwarded to a programmed receiver.

- On
- Off

❖ **RX File Print Qty (Reception File Print Quantity)**

Specify the number of copies to be printed for each fax message received.

- 1 to 10 set(s)

❖ **2 Sided Print**

Specify whether or not received fax messages are to be printed on both sides of paper.

- On
- Off

❖ **RX Reverse Printing (Reception Reverse Printing)**

Specify whether or not received fax messages are to be printed from the last page received.

- On
- Off

❖ **Paper Tray**

Use this function to print fax messages received from programmed senders and fax messages from other senders, using different paper trays. See p.174 "Paper Tray". Display of tray names may differ depending on the options installed.

- Tray 1
- Tray 2
- Tray 3 (option)
- Tray 4 (option)
- Auto Select
- LCT (option)

❖ **Specify Tray for Lines**

Specify a paper tray for each line (telephone, Internet Fax, IP-Fax).

- On
- Off

① Select **[On]** to select a paper tray.

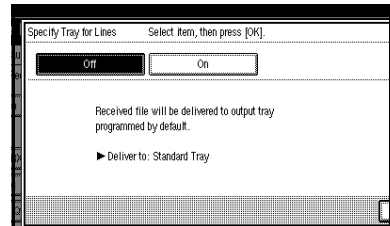

 **Note**

- If you select **[Off]**, the received fax is delivered to a default tray.

② Select the line type.

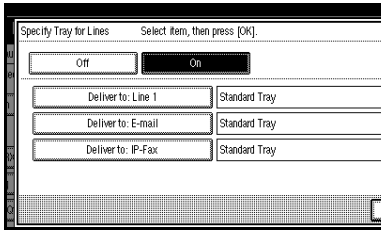

③ Select a tray to deliver the received paper onto, and then press [OK].

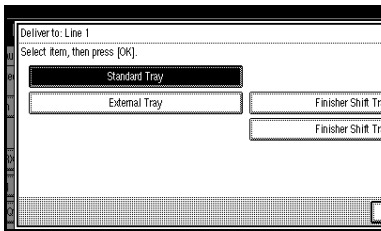

**Note**

- If you want to specify another line type, repeat from step ②.

❖ **Checked Mark**

Specify whether or not a checkered mark is to be printed on the first page of received fax messages.

- On
- Off

❖ **Center Mark**

Specify whether or not a center mark is to be printed halfway down the left side and at the top center of each page received.

- On
- Off

❖ **Print Reception Time**

Specify whether or not received date and time are to be printed at the bottom of received fax messages.

- On
- Off

**E-mail Settings**

❖ **Internet Fax Settings**

You can select to display  or not. When you want to send an Internet Fax, set ON to display the icon.

- On
- Off

❖ **Max. E-mail Size**

Make this setting when you want to limit the size of e-mail messages that are transmitted, if receivers limit e-mail size, or you cannot send large size e-mail for some reason. When this function is set to on, transmission of e-mail that exceeds the set size is aborted.

- On
- Off

**Note**

- When e-mail exceeds the maximum file size, an Error Report is output, and the e-mail is deleted.
- Even when e-mail does not exceed the size limit, it may be rejected if it does not meet the requirements of the server settings.

① Press **[On]**.

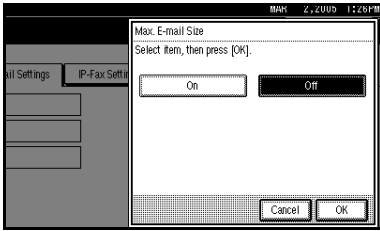

② Enter the maximum e-mail size using the number keys.

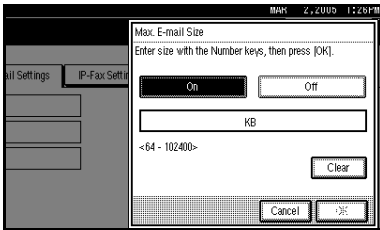

**Note**

- Maximum e-mail size can be between 64 and 102400 KB.
- If you make a mistake, press **[Cancel]** or the **[Clear/Stop]** key, and then enter again.

③ Press **[OK]**.

❖ **SMTP RX File Delivery Settings (SMTP Reception File Delivery Settings)**

This function is available on systems that allow routing of e-mail received via SMTP. See p.93 "Routing E-mail Received via SMTP".

- On
- Off

When an authorized e-mail address is set, e-mail received from addresses that do not match the authorized address is discarded, and an error message is returned to the SMTP server.

The authorized e-mail address is compared with the addresses of e-mail originators, as illustrated by the following examples.

When the authorized e-mail address is set to "@aaa.abcd.com":  
 abc@aaa.abcd.com - accepted  
 def@aaa.xyz.com - not accepted  
 abc@abcd.com - not accepted

**Note**

- No Error Report is output even when e-mail is discarded.

① Press **[On]**.

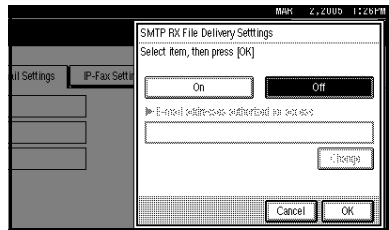

② Press **[Change]**, and then enter the sending e-mail address with transmission permission.

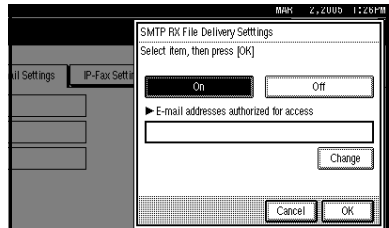

**Note**

- If you make a mistake, press **[Backspace]** or **[Delete All]**, and then enter again.

③ Press **[OK]** twice.

## IP-Fax Settings

Make settings to use IP-Fax.

Set H.323 for the gatekeeper, SIP for SIP server, and gateway for G3 fax if necessary. Check the settings of the network to which this machine is connected before making settings.

 **Note**

The following characters can be used for registration of the alias telephone number in H.323 Setting. Make sure you enter these characters correctly:

- Numbers
- Symbols (# and \*)

The following characters can be used for registration of the SIP User Name in SIP Setting. Make sure you enter these characters correctly:

- Alphanumerical lower and upper cases
- The 21 symbols in the table below.

;	?	:	&	=
+	\$	,	-	_
.	!	~	*	#
'	(	)	%	/
@				

Enter the correct IP addresses for the gatekeeper, SIP server and gateway, which you have been informed by the network Administrator, using numbers and a period (“.”).

◆ **Enable H.323**

Specify whether or not H.323 is used for IP-Fax transmission.

- On
- Off

◆ **Enable SIP**

Specify whether or not SIP is used for IP-Fax transmission.

- On
- Off

◆ **H.323 Settings**

Set the IP address and alias telephone number of the gatekeeper.

 **Note**

If you select “On” using the User Parameters, you can use the gatekeeper server. See p.166 “User Parameters”(switch 34, bit 0)

① Press **[H.323 Settings]**.

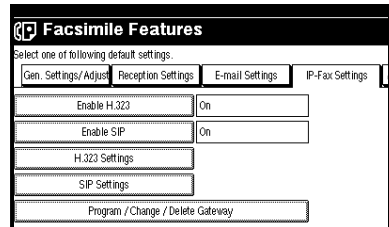

② Press **[Change]** for each property.

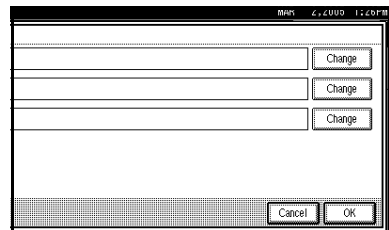



- ③ Enter the IP address and alias telephone number and press **[OK]**.

The screen returns to that of Step ②.

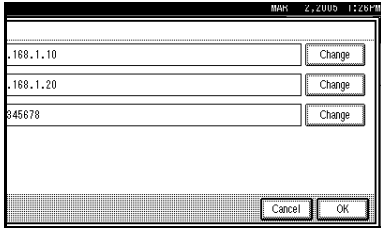

- ④ Press **[OK]**.

❖ **SIP Settings**

Set the SIP server IP address and SIP user name.

**Note**

- ❑ If you select “On” using the User Parameters, you can use the SIP server. See p.166 “User Parameters”(switch 34, bit 1)

- ① Press **[SIP Settings]**.

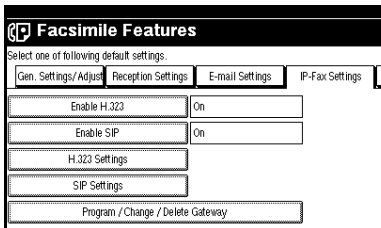

- ② Press **[Change]** for each property.

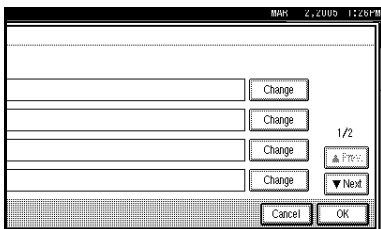

**Note**

- ❑ A proxy server relays call requests and responses.
  - ❑ A redirect server processes request destination inquiries.
  - ❑ A registrar server registers location information of user agents (which correspond to telephones or facsimiles on public telephone lines) on an IP network.
- ③ Enter the IP address and SIP user name, and then press **[OK]**. The screen returns to that of Step ②.

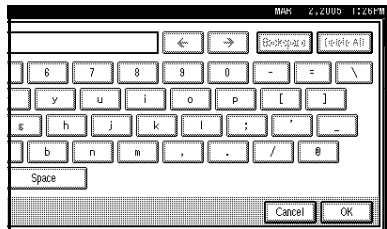

- ④ Press **[OK]**.

❖ **Program / Change / Delete Gateway**

Register, change, or delete the gateway used for transmission to IP-Fax.

- Registering or changing a gateway

- ① Press **[Program / Change / Delete Gateway]**.

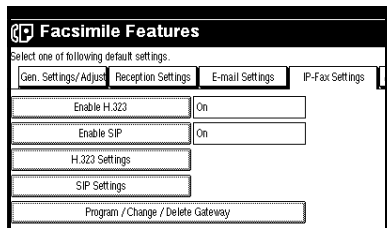

- ② Check **[Program / Change]** is selected.

③ Press a gateway to register.

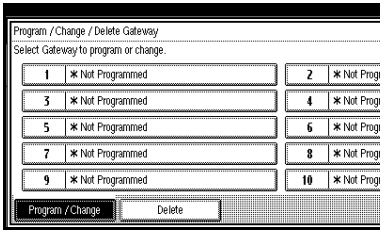

When registering a new gateway, press [**\*Not programmed.**].

④ Press [**Change**] for [**Prefix**].

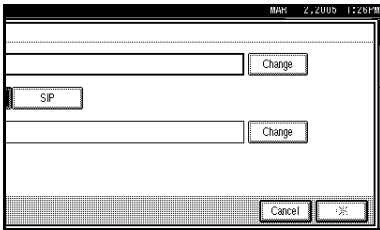

⑤ Enter the Prefix using the number keys, and then press [**OK**].

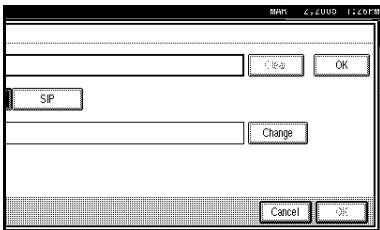

**Note**

❑ To change the existing Prefix, press [**Clear**], and then enter a new ID number.

❑ For documents sent using a gateway to G3 Fax, ID numbers can be used. If the first several digits of IP-Fax number and the gateway-specific ID number are identical, documents can be transmitted using the registered digits of the gateway. For example, if both 03 and 04 have been registered as gateway number while 0312345678 is also specified, documents can be transmitted via a gateway for which 03 is used as ID number.

❑ When you wish to use the gateways regardless of the IP-Fax destination numbers, register only the gateway addresses without registering the ID Numbers.

⑥ Select a protocol.

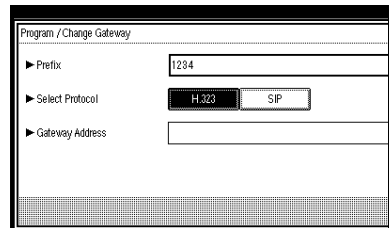

⑦ Press [**Change**] for Gateway Address.

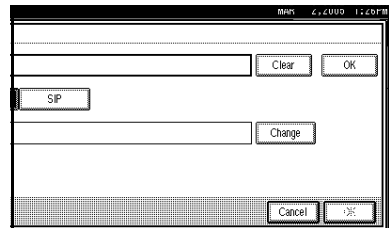

- ⑧ Enter the gateway address, and then press **[OK]**.  
The screen returns to that of Step ⑦.

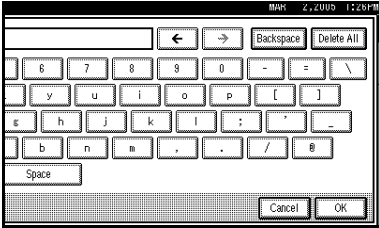

- ⑨ Press **[OK]**.
- Deleting a gateway

- ① Press **[Program / Change / Delete Gateway]**.

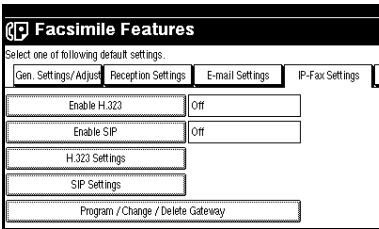

- ② Press **[Delete]**, and then select a gateway to delete.

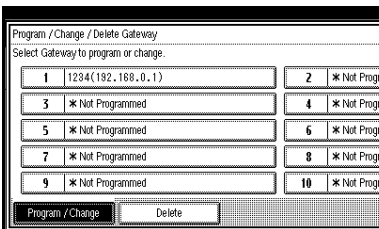

- ③ Press **[Delete]** on the confirmation message.

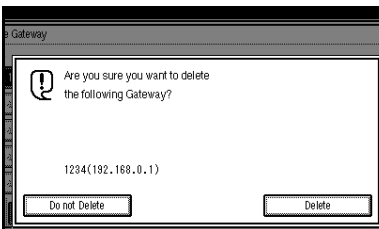

**Note**

- If you do not want to delete the gateway you have selected, press **[Do not Delete]**.
- The screen returns to that of Step ②.
- ④ Press **[Exit]**.

**Note**

- To delete another gateway, repeat steps ② and ③.



# 9. Administrator Setting

## Administrator Tools List

You can program, change, or delete standard messages and auto documents. You can also set the line type for the machine connection, program various IDs (including a Polling ID), fax destinations, and many other items. In addition, you can check the number of documents transmitted and received.

Function name	Description	Reference
Program / Change / Delete Standard Message	You can program, change, or delete standard messages printed at the top of the first page of each incoming message.	p.157 "Programming, Changing, and Deleting Standard Messages"
Store / Change / Delete Auto Document	You can program, change, or delete pages stored as auto documents.	p.158 "Storing, Changing, and Deleting an Auto Document"
Program / Change / Delete Scan Size	You can program, change, or cancel frequently used scan sizes.	p.160 "Programming, Changing and Deleting a Scan Size"
Print Journal	Prints a Journal.	p.162 "Printing Journal"
Transmission Page Count	Checks the transmission and reception, and totals on the display.	p.162 "Counters"
Forwarding	Transfers received messages to a programmed receiver (forwarding destination).	p.162 "Forwarding"
Memory Lock RX	Switches the Memory Lock to on or off. To use it, program an ID for printing a message received in Memory Lock mode.	p.165 "Memory Lock"
ECM	If part of the transmission fails due to a telephone line fault, this function resends the failed part automatically.	p.165 "ECM (Error Correction Mode)"
Parameter Setting	Allows you to change and print the function settings to meet your needs.	p.166 "User Parameters"
Program Special Sender	By programming particular receivers as Special Sender in advance, you can have Special Senders treated differently.	p.174 "Programming/Changing Special Senders"

Function name	Description	Reference
Box Setting	By using SUB and SEP Codes with these functions, you can send messages to another party's box, and retrieve messages stored in boxes.	p.180 "Box Settings"
Transfer Report	Before using Transfer Request, you need this Transfer Report setting.	p.190 "Transfer Report"
Program Confidential ID	Registers an ID required for Confidential communication.	p.191 "Programming a Confidential ID"
Program Polling ID	Registers an ID required for Polling communication.	p.192 "Programming a Polling ID"
Program Memory Lock ID	Registers an ID required for Memory Lock reception.	p.192 "Programming a Memory Lock ID"
Select Dial / Push Phone	Selects a line type when you connect the machine to a G3 analog line.   <b>Note</b> <input type="checkbox"/> This function is not available in some areas.	p.193 "Selecting Dial/ Push Phone"
Reception File Setting	Selects whether received documents are saved on the hard disk to be printed later or printed immediately without being saved.	p.193 "Storing or Printing Received Documents"
Stored RX File User Setting	Set the password to view received and stored documents using a Web Image Monitor or DeskTopBinder Lite.	p.195 "Setting a User for Viewing Received and Stored Documents"
Menu Protection Settings	Set protection so only the Administrator can change menu settings.	p.196 "Menu Protection Settings"

# Using Administrator Settings

## Programming, Changing, and Deleting Standard Messages

Use this function to program standard messages to be printed at the top of the first page of the original. It is useful for personalizing messages such as sending greetings.

### Note

- You can program three standard messages. You cannot change the "Confidential", "Urgent", "Please phone", or "Copy to corres ..." messages.
- Use the same procedure to program and change your messages.

**1** Press the **[User Tools/Counter]** key.

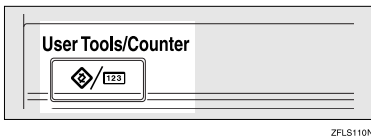

**2** Press **[Facsimile Features]**.

**3** Press **[Administrator Tools]**.

**4** Press **[Program / Change / Delete Standard Message]**.

## Programming or changing standard messages

**1** Check **[Program / Change]** is selected.

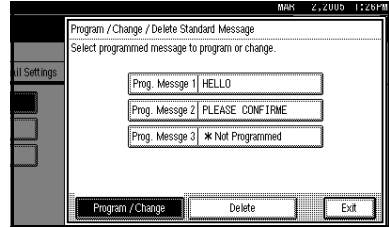

**2** Program or change the message.

Select the message you want to program or change.

**3** Enter a new message.

### Reference

"Entering Text", *General Settings Guide*

**4** Press **[OK]**.

### Note

- To program another message, repeat the procedure from step **1**.
- To cancel a registration, press **[Cancel]**.

## Deleting Standard Messages

- 1 Press **[Delete]**, and then select the message you want to delete.



- 2 Press **[Delete]**.

**Note**

- To delete another message, repeat from step 1.
- To cancel a deletion, press **[Do not Delete]**. The display returns to that of step 1.

- 5 Press **[Exit]**.

- 6 Press the **[User Tools/Counter]** key.  
The standby display appears.

## Storing, Changing, and Deleting an Auto Document

If you often have to send a particular page to people (for example, a map, a standard attachment, or a set of instructions), you can store that page in memory as an Auto Document. This saves rescanning the original every time you want to send it.

Use the following procedure to program a new Auto Document or overwrite an existing one.

You can store the following items in an Auto Document:

- Originals (6 documents maximum, only one page per file).

- Scan settings (resolution, original type, and image density)
- Irregular scan area
- Document name (16 characters maximum)

**Important**

- When about one hour passes after power of the machine is turned off, all fax messages stored in memory are lost. If any messages have been lost for this reason, a Power Failure Report is automatically printed when the operation switch is turned on. Use this report to identify lost messages.

- 1 Press the **[User Tools/Counter]** key.

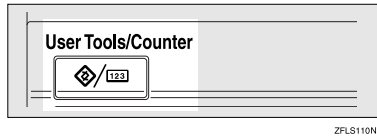

- 2 Press **[Facsimile Features]**.

- 3 Press **[Administrator Tools]**.

- 4 Press **[Store / Change / Delete Auto Document]**.

- 5 Select and follow the appropriate procedure depending on what you want to perform.

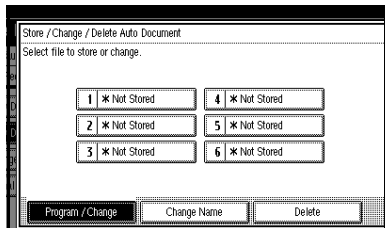

**Note**

- If there are stored files, the file names are shown.



---

## Storing a file

---

- ❶ Check **[Program / Change]** is selected.
- ❷ Select **["Not Stored"]**.
- ❸ Enter a file name, and then press **[OK]**.

 **Reference**

"Entering Text", *General Settings Guide*

---

## Changing a file

---

- ❶ Check **[Program / Change]** is selected.
- ❷ Select the file you want to change.

The "A file is already stored. If another file is stored one will be deleted. Is it OK?" message is shown.

- ❸ Press **[Store]**.

If you want to cancel storing, press **[Do not Store]**.

---

## Changing only a file name

---

- ❶ Press **[Change Name]**.
- ❷ Select the file whose name you want to change.
- ❸ Enter a file name, and then press **[OK]**.

 **Reference**

"Entering Text", *General Settings Guide*

Proceed to step ❸.

- ❹ Place the original, and then select any scan settings you require.

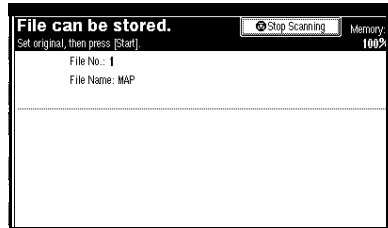

 **Note**

- You can also specify a scan size. See p.15 "Setting a Scan Area", *Facsimile Reference <Basic Features>*.

- ❺ Press the **[Start]** key.

The machine starts to scan and completes scanning.

 **Note**

- To cancel scanning, press **[Stop Scanning]**.

- ❻ Press **[Exit]**.

- ❼ Press the **[User Tools/Counter]** key. The standby display appears.

---

## Deleting an Auto Document

---

 **Note**

- You cannot delete an Auto Document waiting to be transmitted. Delete it after the transmission or cancel the transmission, and then delete the Auto Document.

- ❶ Press the **[User Tools/Counter]** key.

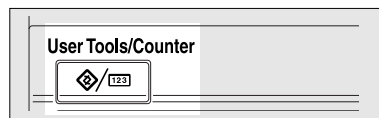

ZFLS110N

- ❷ Press **[Facsimile Features]**.

- 3** Press **[Administrator Tools]**.
- 4** Press **[Store / Change / Delete Auto Document]**.
- 5** Press **[Delete]**, and then select the file you want to delete.

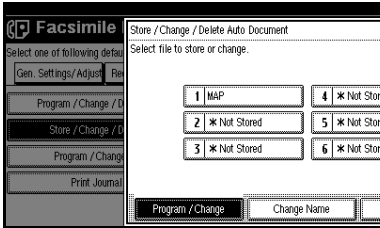

- 6** Press **[Delete]**.

**Note**

- To cancel deleting, press **[Do not Delete]**. The display returns to that of step **5**.

- 7** Press **[Exit]**.

- 8** Press the **[User Tools/Counter]** key.  
The standby display appears.

## Programming, Changing and Deleting a Scan Size

When you select a scan size to scan a non-standard size original, two custom sizes are available (Program Size 1 and Program Size 2). Use these functions to program a custom size in advance.

To change an existing scan size, just use the same procedure.

**Important**

- When programming or changing a scan size, we recommend you make a record of the new size.

**Note**

- You can program up to two sizes.
- You can specify a horizontal length from 128 to 1,200mm, or from 5.5 to 47 inches.

- 1** Press the **[User Tools/Counter]** key.

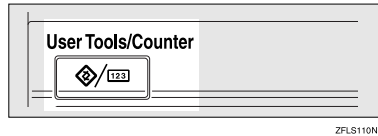

- 2** Press **[Facsimile Features]**.

- 3** Press **[Administrator Tools]**.

- 4** Press **[Program / Change / Delete Scan Size]**.

- 5** Select **[Program Size 1]** or **[Program Size 2]**.

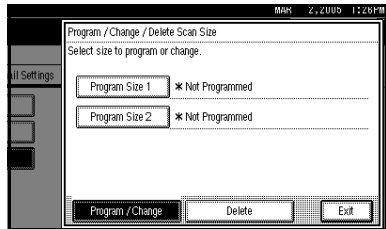

- 6** Enter a horizontal size using the number keys.

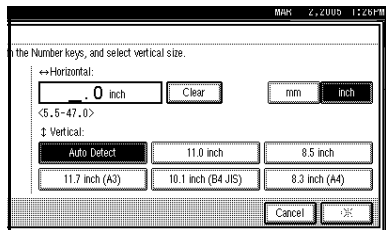

**Note**

- ❑ Each time you press [mm] or [inch], the units switch between “mm” and “inch”. If you enter a length and change the units by pressing [mm] or [inch], the length is converted automatically according to the unit (fractions are rounded off). For example, when you enter [2], [2], and [0] in millimeters and change to “inch”, the length “8.7 inch” is shown on the display. If you press [mm] or [inch] again, “221mm” is displayed.
- ❑ If you make a mistake, press [Clear] or the [Clear/Stop] key, and then try again.
- ❑ To cancel a scan size, press [Cancel].

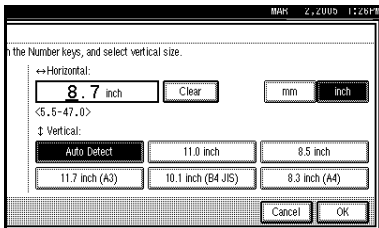
**7** Select a vertical size, and then press [OK].**Note**

- ❑ A displayed vertical size differs depending on the selected unit. When [mm] is selected, [Auto Detect], [210 mm (A4)], [257 mm(B4 JIS)], [297 mm (A3)], [216 mm (8 1/2)], and [279 mm (11)] are shown. When [inch] is selected, [Auto Detect], [8.3 inch (A4)], [10.1inch(B4 JIS)], [11.7 inch (A3)], [8.5 inch], and [11.0 inch] are shown.
- ❑ To cancel a scan size, press [Cancel].

**8** Press [Exit].

- 9** Press the [User Tools/Counter] key.  
The standby display appears.

**Deleting a scan size**

- 1** Press the [User Tools/Counter] key.

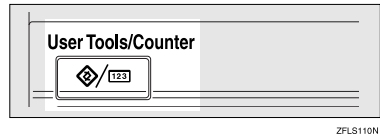

- 2** Press [Facsimile Features].
- 3** Press [Administrator Tools].
- 4** Press [Program / Change / Delete Scan Size].
- 5** Press [Delete], and then select [Program Size 1] or [Program Size 2].

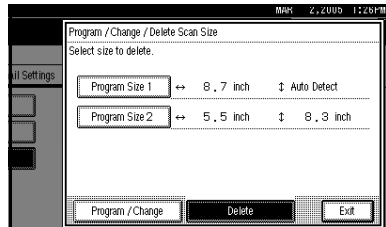

- 6** Press [Yes].

**Note**

- ❑ To cancel deleting, press [No].  
The display returns to that of step 6.

- 7** Press [Exit].

- 8** Press the [User Tools/Counter] key.  
The standby display appears.

## Printing Journal

The Journal allows you to check a maximum of the last 50 communications (receptions & transmissions) performed by the machine. You can print the Journal using the Information menu. See p.27 “Printing the Journal”.

## Counters

This function allows you to check the total number of pages transmitted and received on the display.

- Transmissions:  
Total number of transmitted pages
- Receptions:  
Total number of received pages

**1** Press the **[User Tools/Counter]** key.

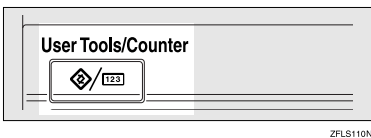

**2** Press **[Facsimile Features]**.

**3** Press **[Administrator Tools]**.

**4** Press **[Transmission Page Count]**.

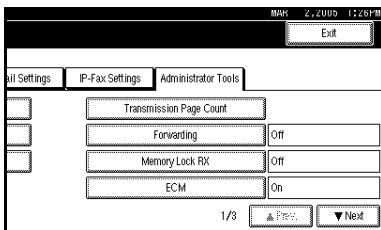

**5** After checking the display, press **[Exit]**.

**6** Press the **[User Tools/Counter]** key.

The standby display appears.

## Forwarding

This function allows you to have messages printed on the machine, and sent to a specified End Receiver.

This is useful if, for example, you are visiting another office and would like a copy of your messages to be sent to that office.

You can also specify a “folder” as the forwarding destination.

### Preparation

To use this function, set Forwarding under Reception Settings to On (enable). See p.147 “Reception Settings”.

### Limitation

- The Forwarding function does not forward messages received with Confidential Reception, Memory Lock, Polling Reception mode, or messages received by Transfer Request.
- You can select end receivers only from among destinations programmed in the Address Book. You cannot specify programmed transfer stations as end receivers.

### Note

- A fax number, e-mail address, IP-Fax destination, and folder can be set as the forwarding destination.
- Even when **[On]** is selected for “Forwarding” in “Reception Settings”, if **[Off]** is selected for the forwarding destination in this function, only printing is performed, not forwarding. See p.147 “Reception Settings”.

- ❑ When you wish to change the end receivers depending on the forwarding destinations, specify the end receivers by the forwarding destinations, at “Special Senders”. A document received from a forwarding destination who has not been specified as the end receiver will be forwarded to the forwarding destination that has been specified in this function. See p.171 “Special Senders to Treat Differently”
- ❑ You can specify whether or not to print forwarded messages. See p.166 “User Parameters” (switch 11, bit 6).
- ❑ Deleting a destination specified as a forward destination from the destination table causes the settings of the forward destination to be deleted, so they must be registered again. When a destination is changed, a message is transmitted to the new destination. If there is no destination of the specified type, you can set to have a certain destination quoted with priority. See p.166 “User Parameters” (switch 32, bit 0).
- ❑ You can program one of the Quick Operation keys with operations for this function. See p.144 “General Settings/Adjustment”.
- ❑ If you have specified a folder for forwarding, you can specify the file format used for forwarding. See p.166 “User Parameters” (switch 21, bit 3).

## Programming an End Receiver

- 1 Press the **[User Tools/Counter]** key.

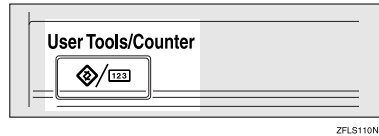

ZFLS110N

- 2 Press **[Facsimile Features]**.
- 3 Press **[Administrator Tools]**.
- 4 Press **[Forwarding]**.
- 5 Press **[On]**.

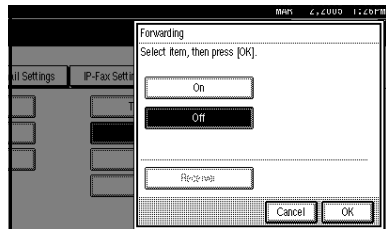

### ! Limitation

- ❑ One end receiver can be registered per a special sender. To register two or more end receivers, use Group Destination. However, a maximum of 500 parties can be specified in a group.

### 📎 Note

- ❑ If there is an End Receiver already programmed, a receiver name is shown. If you want to change the receiver, press **[Receiver]** and proceed to step 6.
- ❑ To cancel Forwarding, press **[Cancel]** and proceed to step 8.

**6** Specify an End Receiver using the destination list, and then press [OK].

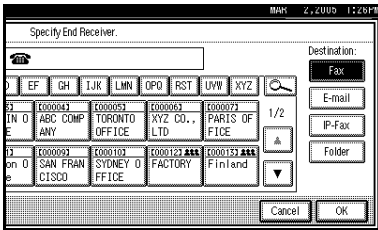

The receiver name is shown to the right of [Receiver].

**Note**

- Press the button on the right of the display to switch the destination between fax number, e-mail address, IP-Fax destination, and folder.
- Set a folder destination in System Initial Setting/Administrator Setting/Register/Change/Delete Address Book. "Registering Folders", *General Settings Guide*.
- If you have specified a folder for forwarding, you can specify the file format used for forwarding. See p.166 "User Parameters" (switch 21, bit 3).
- If you make a mistake, press [Clear] or the [Clear/Stop] key before pressing [OK], and then try again.

**7** Press [OK].

**8** Press the [User Tools/Counter] key. The standby display appears.

**Quitting the forwarding function**

**1** Press the [User Tools/Counter] key.

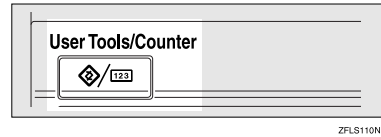

**2** Press [Facsimile Features].

**3** Press [Administrator Tools].

**4** Press [Forwarding].

**5** Press [Off], and then press [OK].

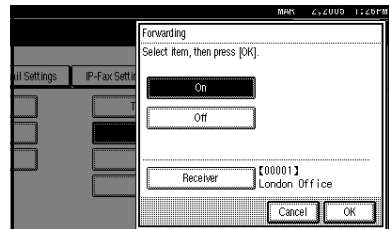

**6** Press the [User Tools/Counter] key. The standby display appears.

**Forwarding Mark**

You can print a Forwarding Mark on the receiver's messages that have been forwarded.

The receiver can distinguish between forwarded messages and usual receptions.

**Note**

- You can specify whether or not to print a Forwarding Mark in the User Parameters. See p.166 "User Parameters" (switch 02, bit 0).

- This function is not available when memory forwarding is performed to a folder destination.

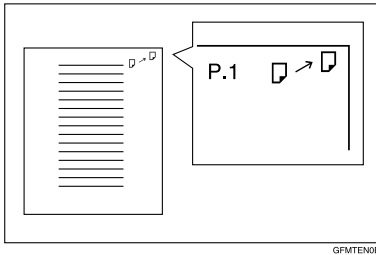

## Memory Lock

When you switch Memory Lock on, received messages are stored in memory and not printed automatically. When a message is received in the Memory Lock mode, the Confidential File (🔒) indicator blinks. To print this message, enter the Memory Lock ID. A user without the ID cannot print the message. This prevents unauthorized users from seeing the message.

### Preparation

To use Memory Lock, program the Memory Lock ID, and then switch Memory Lock on. See p.192 "Programming a Memory Lock ID".

### Limitation

- This function is not available with Internet Fax.

### Note

- To store incoming documents from Special Senders only in Memory Lock, program each sender with "Special Senders to Treat Differently". See p.171 "Special Senders to Treat Differently".

- 1 Press the **[User Tools/Counter]** key.

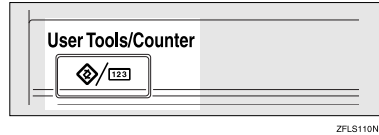

- 2 Press **[Facsimile Features]**.
- 3 Press **[Administrator Tools]**.
- 4 Press **[Memory Lock RX]**.
- 5 Select **[On]** or **[Off]**, and then press **[OK]**.

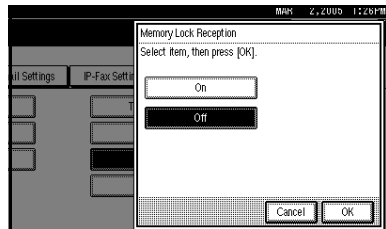

### Note

- To cancel this setting, press **[Cancel]**. The display returns to that of step 4.

- 6 Press the **[User Tools/Counter]** key. The standby display appears.

## ECM (Error Correction Mode)

If part of a transmission fails because of a line problem, the lost data is automatically resent. For this function to work, the other machine must have ECM. You can turn this function on or off through the following procedure.

### Limitation

- This function is not available with Internet Fax.

**Note**

- If you turn ECM off, you cannot use the following functions:
  - JBIG Transmission
  - Super G3 Communication

**1** Press the **[User Tools/Counter]** key.

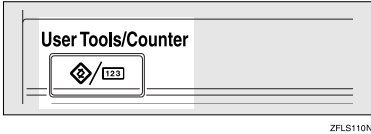

**2** Press **[Facsimile Features]**.

**3** Press **[Administrator Tools]**.

**4** Press **[ECM]**.

**5** Select **[On]** or **[Off]**, and then press **[OK]**.

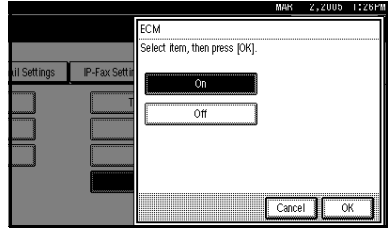

**Note**

- To cancel this setting, press **[Cancel]**. The display returns to that of step **4**.

**6** Press the **[User Tools/Counter]** key. The standby display appears.

## User Parameters

User Parameters allow you to customize various settings to suit your needs. To change function settings, set the User Parameter Switches.

❖ **Switches and Bits**

Each User Parameter has a set of switches, and each of the switches consist of eight bits, whose values are "0" or "1". The right most bit is bit 0 and the left most is bit 7. You can adjust the settings to match your needs by switching the value of bits between "0" and "1".

Switch 02	0	0	1	1	1	0	1	1
	↓	↓	↓	↓	↓	↓	↓	↓
	7	6	5	4	3	2	1	0



## ◆ User Parameter List

User Parameter Switches are outlined below.

Switch	Bit	Item	0	1
02	0	Forwarding Mark	Off	On
	3	TSI Print	Off	On
03	0	Automatic printing of the Communication Result Report	Off	On
	2	Automatic printing of the Memory Storage Report	Off	On
	3	Automatic printing of the Polling Reserve Report	Off	On
	4	Automatic printing of the Polling Result Report	Off	On
	5	Automatic printing of the Immediate TX Result Report	Off	On
	6	Automatic printing of the Polling Transmission Clear Report	Off	On
	7	Automatic printing of the Journal	Off	On
04	0	Automatic printing of the Confidential File Report	Off	On
	1	Automatic printing of Communication Failure Report and Transfer Result Report	Off	On
	4	Indicates the parties	Off	On
	5	Include sender's name on reports	Off	On
	7	Include a portion of the image on reports	Off	On

Switch	Bit	Item	0	1
05	0	Receive Service Call (SC) Condition (Substitute Reception during service call)	Possible (Substitute RX)	Not possible (Reception off)
	2, 1	Substitute the reception when the machine cannot print (because all paper trays have run out of paper, toner is empty, or all paper trays are out of order) 00: Enabled unconditionally (Free) 01: Enabled when Own Name/Own Fax Number is received 10: Enabled for Polling ID match 11: Disabled (Reception off)		
	5	Print sheet is limited to that which has highest priority.	Off	On
	7	Empty tray alert (Paper Empty Warning) even when one paper tray is empty	Off	On
06	6	First page scanned for book originals	From the left page	From the right page
07	2	Parallel Memory Transmission	Off	On
08	2	Authorized Reception Type	Receiving from only specified senders	Receiving all messages except those from specified senders
10	1	Combine two originals	Off	On
	3	Page reduction when printing	Off	On
	5	Reception file setting	Off	On
11	6	Local print when forwarding	Off	On
	7	Polling file after sending (Polling transmission standby time)	Delete (Use Once)	Standby (Save)
14	0	Print documents received with Auto Power-On Reception (Night Printing mode)	Immediate printing (On)	When turning on the operation switch (Off)
	1	Long Document Transmission (Well Log)	Off	On
	2	Batch Transmission	Off	On
	3	Reset when function changed	Off	On
	7	System Parameter List Transmission	Off	On

Switch	Bit	Item	0	1
17	2	Whether you need to press <b>[Add]</b> after entering a Quick Dial/Group Dial when broadcasting	Not necessary	Necessary
	7	Receive messages by pressing the <b>[Start]</b> key when originals are not set.	Off (The machine does not receive messages by pressing the <b>[Start]</b> key.)	On (The machine receives messages by pressing the <b>[Start]</b> key.)
18	0	Print date with Fax Header	Off	On
	1	Print transmitter origin with Fax Header	Off	On
	2	Print file number with Fax Header	Off	On
	3	Print page number with Fax Header	Off	On
19	0	Use paper delivery shift function (Offset Print)	Off	On
	1	Sort Journal by line type	Off	On
20	0	Automatic printing of the LAN-Fax Result Report.	Off	On
	5, 4, 3, 2	Reprinting time of stored documents in memory that could not be printed using LAN-Fax Driver 0000: 0 minute / 0001: 1 minute / 0010: 2 minutes / 0011: 3 minutes / 0100: 4 minutes / 0101: 5 minutes / 0110: 6 minutes / 0111: 7 minutes / 1000: 8 minutes / 1001: 9 minutes / 1010: 10 minutes / 1011: 11 minutes / 1100: 12 minutes / 1101: 13 minutes / 1110: 14 minutes / 1111: 15 minutes		
21	0	Print results of sending Reception Notice Request message	Off (print only when an error occurs)	On
	1	Respond to e-mail reception acknowledgment request	Off	On
	3	File format for forwarded folders	TIFF	PDF
	4	Transmit Journal by E-mail	Off	On
	6	Not display Network error	Display (Off)	Not display (On)
	7	Transmit Error Mail Notification	On	Off
24	1, 0	Store a message in memory that could not be transmitted 00: Off, 01: Store for 24 hours, 11: Store for 72 hours		
25	2	Fax or telephone in Auto Switch mode	Fax	Telephone
	4	RDS	Off	On

Switch	Bit	Item	0	1
32	0	Quotation Priority for a destination when there is no destination of the specified type.	Paper Output Priority <Priority Order> 1. IP-Fax destination 2. Fax number 3. E-mail address 4. Folder	Electronic Output Priority <Priority Order> 1. E-mail address 2. Folder 3. IP-Fax destination 4. Fax number
34	0	Use gatekeeper server with IP-Fax	Off	On
	1	Use SIP server with IP-Fax	Off	On

### Changing the User Parameters

#### Preparation

Access to some User Parameter Settings requires installation of optional equipment, or that other settings be made beforehand.

#### Important

- We recommend you print and keep a User Parameter list when you program or change a User Parameter. See p.171 "Printing the User Parameter List".
- Do not change any bit switches other than those shown on the previous pages.

**1** Press the **[User Tools/Counter]** key.

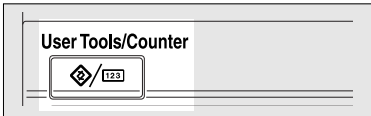

ZFLS110N

**2** Press **[Facsimile Features]**.

**3** Press **[Administrator Tools]**.

**4** Press **[Parameter Setting]**.

**5** Select the switch number you want to change.

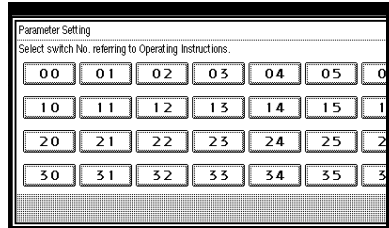

**6** Select the bit number you want to change.

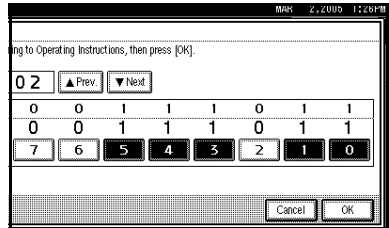

When the bit number is pressed, the current value switches between 1 and 0.

#### Note

- Repeat from step **6** to change another bit number for the same switch.

**7** Press **[OK]**.

**Note**

- To cancel these settings, press **[Cancel]**. The display returns to that of step **6**.

**8** Repeat steps **5** and **7** to change the switch settings.

**9** After all the settings are finished, press **[Exit]**.

**10** Press the **[User Tools/Counter]** key.  
The standby display appears.

### Printing the User Parameter List

Print this list to see the current User Parameter settings. However, only items of importance or often-used items are included in the list.

**1** Press the **[User Tools/Counter]** key.

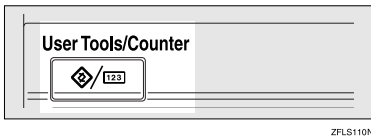

ZFLS110N

**2** Press **[Facsimile Features]**.

**3** Press **[Administrator Tools]**.

**4** Press **[Print List]** next to "Parameter Setting".

**Note**

- To cancel printing a list, press **[Cancel]**. The display returns to that of step **4**.

**5** Press the **[Start]** key.

**Note**

- To cancel printing a list after pressing the **[Start]** key, press **[Stop Printing]**. The display returns to that of step **4**.

**6** Press the **[User Tools/Counter]** key.

The standby display appears.

## Special Senders to Treat Differently

By programming particular receivers in advance, you can set the following function for each receiver:

- Authorized RX
- Forwarding
- Reception File Print Qty
- Print 2 Sided
- Memory Lock
- RX Reverse Printing
- Paper Tray

Use the Own Name or Own Fax Number to program your receivers. If the receiver has a machine of the same manufacturer, program an Own Name that has already been programmed as a receiver. If the machine is not of the same manufacturer, use Own Fax Number. You can apply the same settings to all programmed numbers. You can then customize the settings for individual numbers as necessary using the Special Sender Registration function.

The following items can be programmed.

- Special Senders (Up to 30. A maximum of 20 characters for each name when using G3.)
- Full/Partial agreement  
When you program own names and facsimile names for multiple destinations, you can program a common sequence of characters to identify destinations using Partial agreement.

◆ **Using Full matching**

Destination to be programmed (Own Name)	Number of programmed identifications
NEW YORK BRANCH HONG KONG BRANCH SYDNEY BRANCH	3

◆ **Using Partial matching**

Destination to be programmed (Own Name)	Number of programmed identifications
BRANCH	1

 **Note**

- You can program up to 30 wild cards.
- Spaces are ignored when identifications are compared.
- You can use wild cards for the following functions:
  - See p.174 “Programming/Changing Special Senders”.
  - See p.175 “Authorized RX (Authorized Reception)”.
  - See p.175 “Forwarding”.

 **Limitation**

- You cannot program senders as Special Senders if they do not have Own Name or Own Fax Number programmed.
- The machine cannot differentiate between Polling Reception and Free Polling documents from Special Senders.
- You cannot use the following functions with Internet Fax receptions.
  - Authorized RX
  - Reception File Print Qty

- Memory Lock
- RX Reverse Printing

 **Note**

- You can program up to 24 characters for the sender.
- You can check Own Name and Own Fax Number using the Journal. You can check programmed Special Senders using the specified sender list. See p.27 “Printing the Journal”. See p.180 “Printing the Special Sender List”.
- To use Forwarding, Print 2 Sided, or Paper Tray with Internet Fax reception, program the sender's e-mail address.
- If you select “Off” for the Special Sender function in “Initial Set Up”, the settings will be the same as the Reception Settings. See p.147 “Reception Settings”.

---

**Authorized Reception**

---

Use this function to limit incoming senders. The machine only receives faxes from programmed Special Senders, and therefore, it helps you screen out unwanted messages, such as junk mail, and saves wasting fax paper.

 **Note**

- To use this function, program the Special Senders function, and then select “On” in “Authorized RX” with “Reception Settings”. See p.147 “Reception Settings”. See p.166 “User Parameters” (switch 08, bit 2).
- Without programming Special Senders, the Authorized RX function will not work, even if you select “On”.

- You can select to receive only from programmed senders or receive only from senders other than those programmed in User Parameters. See p.166 "User Parameters" (switch 08, bit 2).
- If you select "Off" for "Authorized RX" in "Initial Set Up", the settings will be the same as the Reception Mode settings. See p.147 "Reception Settings".
- You can change Special Senders in the same way as you program them.

---

## Forwarding

---

Use this function to print received messages, and then transfer them to those receivers programmed beforehand.

Folder destination can be registered.

It is also possible to forward faxes sent only by senders programmed as Special Senders.

### Note

- To use this function, program your Special Senders, and then select "On" for "Forwarding" in "Reception Settings". See p.147 "Reception Settings".
- If you specify "On" in "Forwarding" and select [**Same as Basic Settings**], the fax message will be forwarded to the other ends programmed in "Specify End Receiver". See p.162 "Forwarding".
- If you do not program any Special Senders, the machine transfers all incoming documents to the other end specified in "Specify End Receiver".
- You can set the fax destination, Internet fax destination, IP-Fax destination or folder destination, as a forward destination.

- Set folder destinations using the Address Book Management function under System Settings. See "Registering Folders", *General Settings Guide*.
- If you have specified a folder for forwarding, you can specify the file format used for forwarding. See p.166 "User Parameters" (switch 21, bit 3).

---

## Reception File Print Quantity

---

Use this function to print the specified number of copies of documents received from programmed senders (Special Senders). If you do not program any Special Senders, the machine prints the specified number of copies for all received documents.

### Limitation

- You cannot use multi-copy printing with Polling Reception, Confidential Reception, or Memory Lock.

### Note

- You can specify up to 10 copies.

---

## Print 2 Sided

---

Use this function to print on both sides of paper.

### Limitation

- If you select the bypass tray for "Paper Tray", duplex printing is disabled.
- An external tray cannot be used as a destination for a two-sided-printed sheet.

## Memory Lock

Use this function to store incoming documents from programmed senders (Special Senders) in memory without printing them. People without the Memory Lock ID cannot print the documents, and therefore this function is useful for receiving confidential documents. If you do not program any senders, the machine receives fax message from all senders using Memory Lock reception.

### Preparation

You must register Memory Lock ID in advance. See p.192 “Programming a Memory Lock ID”.

### Reference

p.192 “Programming a Memory Lock ID”

### Limitation

- If you program the same sender in Memory Lock and Forwarding, Forwarding is disabled.

## Reception Reverse Printing

Use this function to print the pages in reverse order. See p.100 “Reverse Order Printing”.

## Paper Tray

Use this function to print documents received from programmed senders (Special Senders) and the documents from other senders on different types of paper.

For example, if blue paper is in Tray 1 and white paper is in Tray 2, the machine prints the documents from Special Senders on the blue paper and prints the documents from other senders on the white paper, making it easy for you to separate the two.

If you do not program any Special Senders, the machine outputs documents received from all senders using the default paper tray.

### Limitation

- For Polling Reception, you cannot select the paper tray.

### Note

- If the machine receives a message that has a different size from the paper in the specified tray, the machine prints it after splitting it or minimizing its size. See p.100 “Page Separation and Length Reduction”.
- Selection of the bypass tray enables you to specify the paper size in “Scan Area”.

## Programming/Changing Special Senders

- 1** Press the **[User Tools/Counter]** key.

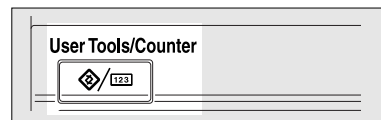

ZFLS110N

- 2** Press **[Facsimile Features]**.
- 3** Press **[Administrator Tools]**.
- 4** Press **[Program Special Sender]**.
- 5** Check **[Program / Change]** is selected.



## 6 Select the destination to program or change.

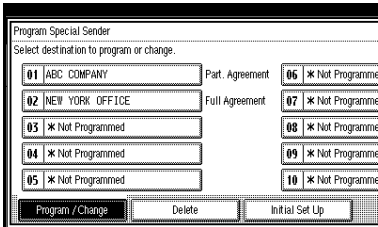

When programming a new Special Sender, press [**\* Not Programmed**].

## 7 Enter a destination name, and then press [OK].

Enter a destination name using Own Name or Own Fax Number.

### Reference

"Entering Text", *General Settings Guide*

## 8 Press [Full Agreement] or [Partial Agreement].

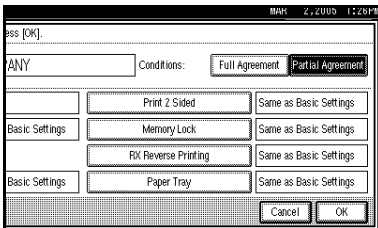

## 9 Select the item you want to program.

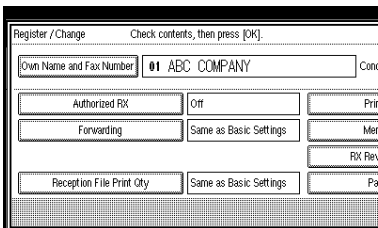

### Note

- You must select only the item you want to program.
- To cancel these settings, press [**Cancel**]. The display returns to that of step 5.

## Authorized RX (Authorized Reception)

- 1 Select [**Authorized RX**].
- 2 Press [**On**] or [**Off**], and then press [**OK**].

### Note

- After you perform step 1, set "Authorized RX" of "Reception Settings" to "On". See p.147 "Reception Settings".

## Forwarding

- 1 Select [**Forwarding**].
- 2 Select [**On**] or [**Off**].

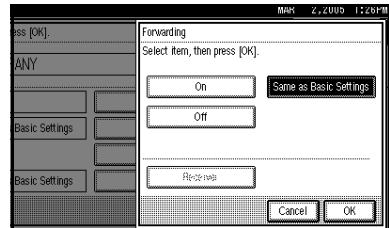

If you select [**Off**], proceed to step 4.

### Note

- Selecting [**Same as Basic Settings**] will result in the same setting made for "Forwarding" under "Administrator Tools". See p.162 "Forwarding".

- Press the destination key of a forward destination, and then press [OK].

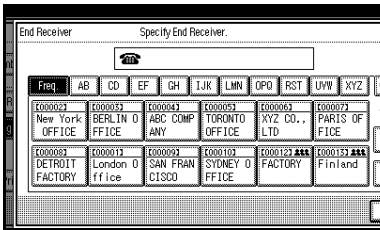

**Limitation**

- One forward destination can be registered for a destination. To register two or more forward destinations, use Group Destinations. However a maximum of 500 parties can be specified in a group.

**Note**

- Press the button on the right of the display to switch the destination between fax number, e-mail address, IP-Fax destination, and folder.
- Set folder destinations using the Address Book Management function under System Settings. See "Registering Folders", *General Settings Guide*.
- When a folder is specified as the forward destination, you can set a file format for forwarding. See p.166 "User Parameters" (switch 21, bit 3).

- Deleting a destination specified as a forward destination from the destination table causes the settings of the forward destination to be deleted, so they must be registered again. When a destination is changed, a message is transmitted to the new destination. If there is no destination of the specified type, you can set a certain destination to be priority quoted. See p.166 "User Parameters" (switch 32, bit 0).

- Press [OK].

- Press [OK].

**Note**

- After you perform step 1, set "Forwarding" of "Reception Settings" to "On". See p.147 "Reception Settings".

Reception File Print Qty

- Select [Reception File Print Qty].

- Press [Number of Sets].

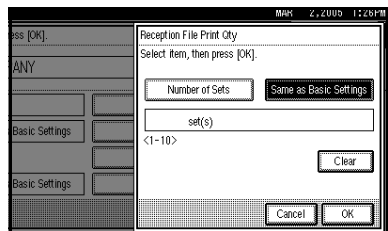

**Note**

- Selecting [Same as Basic Settings] will result in the same setting made for "RX File Print Qty" of "Reception Settings". See p.147 "Reception Settings".

- Enter the print quantity using the number keys, and then press [OK].

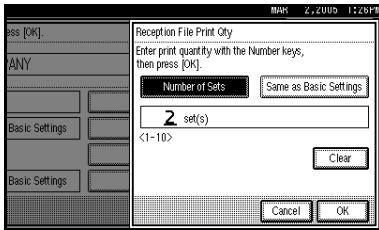

#### Note

- If you make a mistake, press [Clear] or the [Clear/Stop] key before pressing [OK], and then try again.

### Print 2 Sided

- Select [Print 2 Sided].
- Select [On] or [Off], and then press [OK].

#### Note

- Selecting [Same as Basic Settings] will result in the same setting made for "2 Sided Print" of "Reception Settings". See p.147 "Reception Settings".

### Memory Lock

- Select [Memory Lock].
- Select [On] or [Off], and then press [OK].

#### Note

- Selecting [Same as Basic Settings] will result in the same setting made for "Program Memory Lock ID" under "Administrator Tools". See p.165 "Memory Lock".

### RX Reverse Printing (Reception Reverse Printing)

- Select [RX Reverse Printing].
- Select [On] or [Off], and then press [OK].

#### Note

- Selecting [Same as Basic Settings] will result in the same setting made for "RX Reverse Printing" of "Reception Settings". See p.147 "Reception Settings".

### Paper Tray

- Select [Paper Tray].
- Select the tray you want to use, and then press [OK].

#### Note

- Selecting [Same as Basic Settings] will result in the same setting made for "Paper Tray" of "Reception Settings". See p.147 "Reception Settings".

- Press [OK].

A Special Sender has been programmed.

#### Note

- To program another sender, repeat the procedure from step 6.

- Press [Exit].

- Press the [User Tools/Counter] key.

The standby display appears.

## Programming Initial Set Up of a Special Sender

Use this function to program “Initial Set Up” of a Special Sender. You can also specify the Bypass Tray Paper Size.

**1** Press the **[User Tools/Counter]** key.

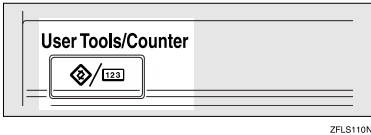

**2** Press **[Facsimile Features]**.

**3** Press **[Administrator Tools]**.

**4** Press **[Program Special Sender]**.

**5** Press **[Initial Set Up]**.

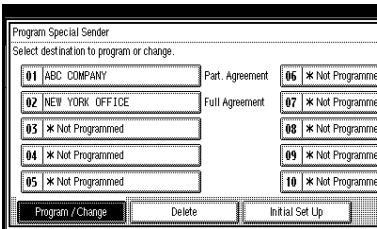

**6** Select the function you want to program.

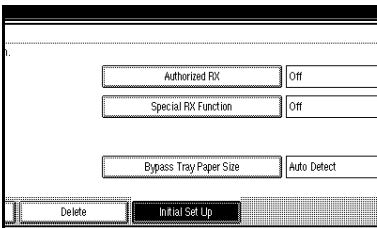

**Note**

- In this feature, “Authorized RX” has the same settings as “Reception Settings”. See p.147 “Reception Settings”.

## Programming Authorized RX and Special RX Function

**1** Select **[Authorized RX]** or **[Special RX Function]**.

**2** Select **[On]** or **[Off]**, and then press **[OK]**.

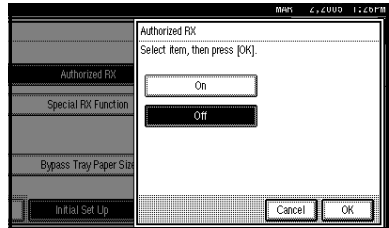

The illustration shows the “Authorized RX” display as an example.

## Programming Bypass Tray Paper Size

**1** Press **[Bypass Tray Paper Size]**.

You can select a size from **[Auto Detect]**, **[Standard Size]**, or **[Custom Size]**.

If you select **[Auto Detect]**, proceed to steps **2** and **7**.



If you select **[Standard Size]**, proceed to steps **2**, **3**, and **7**.

If you select **[Custom Size]**, proceed to steps **2**, and **4** to **7**.

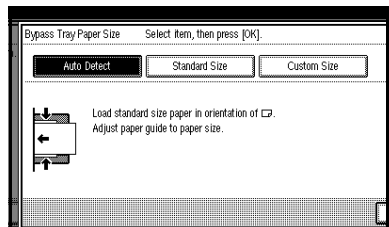
**2** Select the size you want to program.



**Note**

- ❑ If you select **[Auto Detect]**, the machine recognizes the paper size automatically.
  - The machine will detect the paper size for the bypass tray as the short edge of the paper is inserted into the machine. Even if you placed an A4 size sheet in the  orientation, the machine will detect it as A3 .
- ❑ If you select **[Standard Size]**, select a paper size displayed, and then proceed to step 7.
- ❑ If you select **[Custom Size]**, proceed to step 4.

- 3 Select the size you want to program from the sizes shown.
- 4 Make sure that **[Vertical]** is selected.
- 5 Enter the vertical size of the paper using the number keys, and then press **[#]**.

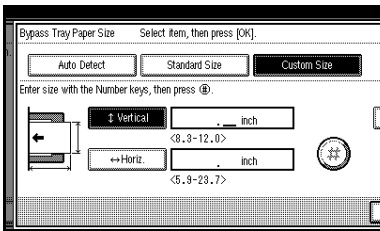
**Note**

- ❑ You can specify a vertical size from 210mm (8.3 inch) to 305mm (12.0 inch). You cannot enter a size smaller than 210mm or larger than 305mm.

- ❑ Each time you press **[mm]** or **[inch]**, the units switch between “mm” and “inch”. If you enter a length and change the units by pressing **[mm]** or **[inch]**, it is converted automatically (fractions are rounded off).

- 6 Enter the horizontal size of the paper using the number keys, and then press **[#]**.

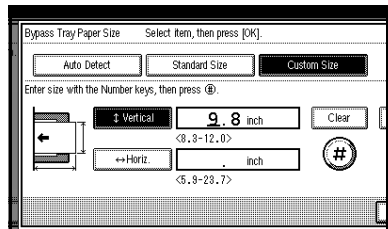
**Note**

- ❑ You can specify a horizontal size from 148mm (5.9 inch) to 600mm (23.7 inch). You cannot enter a size smaller than 148mm or larger than 600mm.
- ❑ Each time you press **[mm]** or **[inch]**, the units switch between “mm” and “inch”. If you enter a length and change the units by pressing **[mm]** or **[inch]**, it is converted automatically (fractions are rounded off).

- 7 Press **[OK]**.

- 7 Press **[Exit]**.

- 8 Press the **[User Tools/Counter]** key.

The standby display appears.

## Deleting a Special Sender

Use this function to program “Initial Set Up” of a Special Sender. The Bypass Tray Paper Size can also be specified.

**1** Press the **[User Tools/Counter]** key.

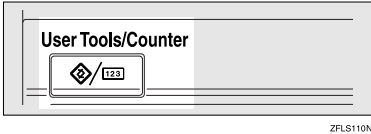

**2** Press **[Facsimile Features]**.

**3** Press **[Administrator Tools]**.

**4** Press **[Program Special Sender]**.

**5** Press **[Delete]**, and then select the Special Sender you want to delete.

**6** Press **[Delete]**.

**Note**

- To cancel deleting a special sender, press **[Do not Delete]**. The display returns to that of step **5**.

**7** Press **[Exit]**.

**8** Press the **[User Tools/Counter]** key.  
The standby display appears.

## Printing the Special Sender List

**1** Press the **[User Tools/Counter]** key.

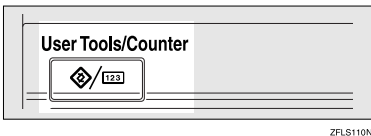

**2** Press **[Facsimile Features]**.

**3** Press **[Administrator Tools]**.

**4** Press **[Print List]** next to “Program Special Sender”.

**Note**

- To cancel printing, press **[Cancel]**. The display returns to that of step **4**.

**5** Press the **[Start]** key.

**Note**

- To cancel printing after pressing the **[Start]** key, press **[Stop Printing]**. The display returns to that of step **4**.

**6** Press the **[User Tools/Counter]** key.  
The standby display appears.

## Box Settings

The following functions are for delivery and transfer of messages:

- Personal Box
- Information Box
- Transfer Box

**Reference**

For details about how to set up these functions:

- p.181 “Programming/changing Personal Boxes”
- p.184 “Programming/changing Information Boxes”
- p.186 “Programming/changing Transfer Boxes”

For details about how to print out and delete messages stored in boxes:

- p.40 “Personal Boxes”
- p.42 “Information Boxes”

### 📌 Limitation

- You cannot set the same Box code on two different boxes.
- Transmission or programming may not be allowed if there is not enough free memory left. The amount of free memory left differs depending on the optional equipment installed.

### 📌 Note

- The combined total of items that can be stored using the Personal Box, Information Box, and Transfer Box functions is 150.

## Programming/changing Personal Boxes

This section describes how to program Personal Boxes.

You can store the following items:

- Box name (required)  
Up to 20 characters long
- SUB Code (required)  
Up to 20 characters long and can be composed of digits 0-9, "#", "\*", and spaces (the first character cannot be a space).
- Password (optional)  
Up to 20 characters long and can be composed of digits 0-9, "#", "\*", and spaces (the first character cannot be a space).

### 📌 Note

- When programming a password, a mark is displayed before the Box name.
- Receiver (optional)  
You can program one delivery destination for each Personal Box. Specify a delivery destination programmed in Quick Dial.

### 📌 Note

- You can specify a fax number, Internet Fax destination and IP-Fax destination as the transmission destination.
- The contents of the Personal Box will be saved until printing is completed.
- The Fax Header is not printed on delivered messages.
- If a message cannot be delivered, a Communication Failure Report is printed and the message is saved as a Confidential Reception document.
- You can edit boxes in the same way you program them. However, to change the SUB Code itself, you must delete the box, and then program a new SUB Code.
- If a destination in the destination table is deleted after being registered, delivery is not performed and the settings of the delivery destination are also deleted. Also, when a delivery destination is changed, a message is sent to the changed destination. If there is no destination of the specified type, you can set a certain destination to be priority quoted. See p.166 "User Parameters" (switch 32, bit 0).

### 🔍 Reference

p.40 "Personal Boxes"

- 1** Press the **[User Tools/Counter]** key.

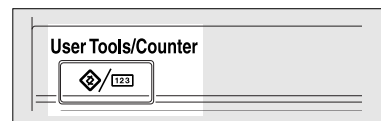

ZFLS110N

- 2** Press **[Facsimile Features]**.
- 3** Press **[Administrator Tools]**.
- 4** Press **[Box Setting]**.

**5** Check that [Program / Change] is selected.

**6** Select a box to program.

When programming a new box, press [\* Not Programed].

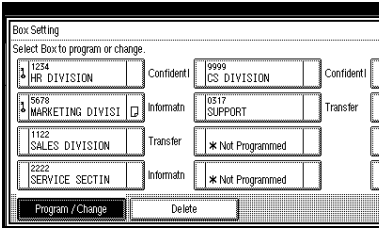

**Note**

- To change a box already programmed, press it and proceed to step 9.

**7** Press [Personal Box].

**8** Enter a box name, and then press [OK].

**Reference**

“Entering Text”, *General Settings Guide*

**9** Enter a SUB Code.

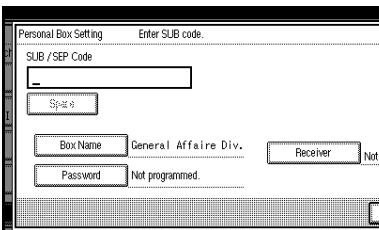

**Note**

- To change the SUB Code, press [Clear] or the [Clear/Stop] key, and then try again. To change a Box name, press [Box Name], and then repeat the procedure from step 8.

**10** Specify the settings you require.

If you do not want to program a password or receiver, proceed to step 11.

Programming a password

**1** Press [Password].

**2** Enter a password, and then press [OK].

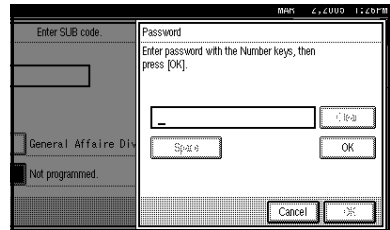

**Note**

- If you make a mistake, press [Clear] or the [Clear/Stop] key before pressing [OK], and then try again.

**3** Re-enter the password, and then press [OK].

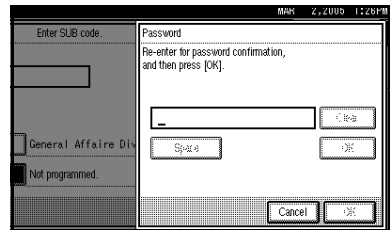

**Note**

- If you make a mistake, press [Clear] or the [Clear/Stop] key before pressing [OK], and then try again.
- To change the password after pressing [OK], press [Change] and repeat steps 2 and 3, or press [Cancel] and repeat the procedure from step 1.

**4** Press [OK].



## Programming an End Receiver

- 1 Press **[Receiver]**.
- 2 Select a destination using the Quick Dial Table, and then press **[OK]**.

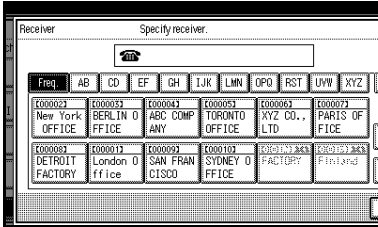

### Note

- Press the button shown on the right side of the screen to switch the destination among fax number, Internet Fax address and IP-Fax address.

- 11 Press **[OK]**.
- 12 Press **[Exit]**.
- 13 Press the **[User Tools/Counter]** key.  
The standby display appears.

## Deleting Personal Boxes

This section describes how to delete Personal Boxes.

### Limitation

- If messages have been programmed in the box, you cannot delete the box.

- 1 Press the **[User Tools/Counter]** key.

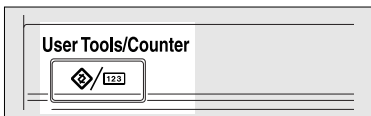

ZFLS110N

- 2 Press **[Facsimile Features]**.

- 3 Press **[Administrator Tools]**.
- 4 Press **[Box Setting]**.
- 5 Press **[Delete]**, and then select the box you want to delete.

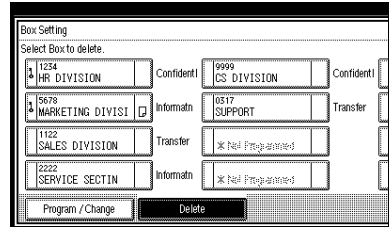

## With a programmed password

- 1 Enter a password using the number keys, and then press **[OK]**.

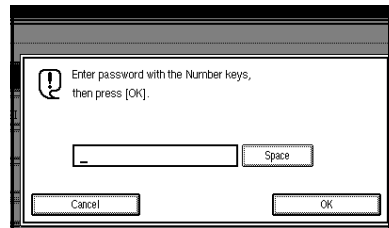

### Note

- If you make a mistake, press **[Clear]** or the **[Clear/Stop]** key.

- 6 Press **[Delete]**.

### Note

- To cancel deleting a box, press **[Do not Delete]**. The display returns to that of step 6.

- 7 Press **[Exit]**.

- 8 Press the **[User Tools/Counter]** key.  
The standby display appears.

## Programming/changing Information Boxes

This section describes how to set up an Information Box.

You can store the following items:

- Box name (required)  
Up to 20 characters long
- SEP Code (required)  
Up to 20 characters long and can be composed of digits 0-9, "#", "\*", and spaces (the first character cannot be a space).
- Password (optional)  
Up to 20 characters long and can be composed of digits 0-9, "#", "\*", and spaces (the first character cannot be a space).

When programming a password, a mark is displayed before the Box name.

### Note

- You can edit boxes in the same way you program them. However, to change the SEP Code itself, you must delete the box, and then program a new SEP Code.
- If a destination in the destination table is deleted after being registered, delivery is not performed and the settings of the delivery destination are also deleted. Also, when a delivery destination is changed, a message is sent to the changed destination. If there is no destination of the specified type, you can set a certain destination to be priority quoted. See p.166 "User Parameters" (switch 32, bit 0).

### Reference

p.42 "Information Boxes"

- 1** Press the **[User Tools/Counter]** key.

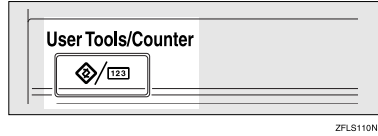

ZFLS110N

- 2** Press **[Facsimile Features]**.
- 3** Press **[Administrator Tools]**.
- 4** Press **[Box Setting]**.
- 5** Check that **[Program / Change]** is selected.
- 6** Select the box to program.

When programming a new box, press **[\* Not Programed]**.

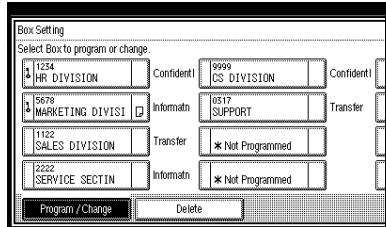

### Note

- To change a box already programmed, press it, and then proceed to step 9. If a password has been programmed, enter the password, press **[OK]**, and then proceed to step 9.

- 7** Press **[Information Box]**.
- 8** Enter a box name, and then press **[OK]**.

### Reference

"Entering Text", *General Settings Guide*

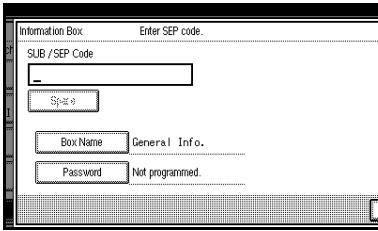
**9** Enter the SEP Code.**Note**

- ❑ To change the SEP Code, press **[Clear]** or the **[Clear/Stop]** key, and then try again. To change the box name, press **[Box Name]**, and then repeat the procedure from step 8.

**10** Press **[Password]**.**Note**

- ❑ If you do not want to program a password, proceed to step 14.

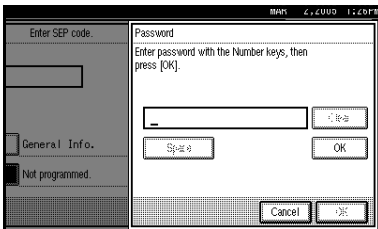
**11** Enter a password, and then press **[OK]**.**Note**

- ❑ If you make a mistake, press **[Clear]** or the **[Clear/Stop]** key before pressing **[OK]**, and then try again.

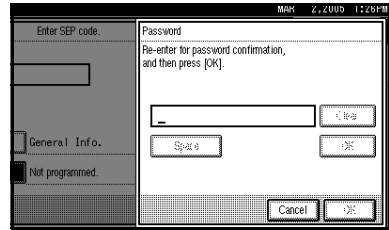
**12** Re-enter the password, and then press **[OK]**.**Note**

- ❑ If you make a mistake, press **[Clear]** or the **[Clear/Stop]** key before pressing **[OK]**, and then try again.
- ❑ To change the password after pressing **[OK]**, press **[Change]** and repeat steps 11 and 12, or press **[Cancel]** and repeat the procedure from step 10.

**13** Press **[OK]**.**14** Press **[OK]**.**15** Press **[Exit]**.**16** Press the **[User Tools/Counter]** key.  
The standby display appears.**Deleting Information Boxes**

This section describes how to delete Information Boxes.

**Limitation**

- ❑ If messages have been programmed in the box, you cannot delete the box.

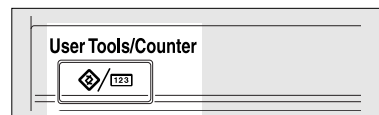
**1** Press the **[User Tools/Counter]** key.

ZFLS110N

- 2** Press [**Facsimile Features**].
- 3** Press [**Administrator Tools**].
- 4** Press [**Box Setting**].
- 5** Press [**Delete**], and then select the box you want to delete.

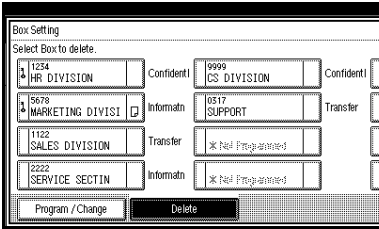

With a programmed password

- 1** Enter a password using the number keys, and then press [**OK**].

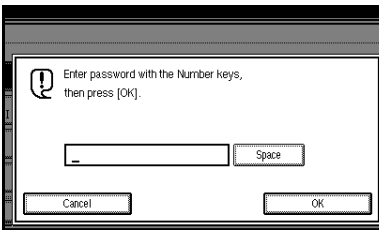

- Note**
  - If you make a mistake, press [**Clear**] or the [**Clear/Stop**] key.

- 6** Press [**Delete**].

- Note**
  - To cancel deleting a box, press [**Do not Delete**]. The display returns to that of step **5**.

- 7** Press [**Exit**].

- 8** Press the [**User Tools/Counter**] key. The standby display appears.

**Programming/changing Transfer Boxes**

This function turns your machine into a fax relay station. Documents sent with a SUB Code that matches the SUB Code programmed as a Transfer Box are received, and then relayed to a programmed receiver.

Since documents can be sent to multiple destinations in a single transfer request, you can economize on call charges when sending to remote destinations.

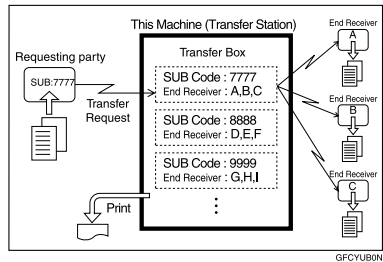

- Note**
  - Inform the Requesting Party of the SUB Code assigned to the Transfer Box. When they want to have a message transferred by your machine, ask them to send the message using SUB Code Transmission and specifying this SUB Code. If a password has also been programmed, inform them of this too, and ask them to enter it as the SID code.

You can store the following items:

- Box name (required)  
Up to 20 characters
- SUB Code (required)  
Up to 20 characters long and can be composed of digits 0-9, “#”, “\*”, and spaces (the first character cannot be a space).

- Password (optional)  
Up to 20 characters long and can be composed of digits 0-9, “#”, “\*”, and spaces (the first character cannot be a space).

#### Note

- When programming a password, a mark is displayed in front of the Box name.

- End Receiver (required)  
You can store five End Receivers (destinations to which messages will be forwarded) for each box. Specify End Receivers with Quick Dials or Groups assigned to Quick Dials that have been programmed beforehand.

#### Limitation

- After messages are transferred, Transfer Result Reports are not sent back to the sender.

#### Note

- You can specify the Internet fax destination and IP-Fax destination as a reception station.
- After messages are transferred, they are deleted.
- When this function is turned on, the machine prints out the received messages it transfers and a Transfer Result Report after the transfer has finished. If you want to turn this function off, please contact your service representative.
- When the programmed receiver is a Multi-step Transfer Group Dial, Multi-step Transfer takes place. For more information, contact your service representative.
- You can edit boxes in the same way you program them.

- If you delete a destination specified as a reception destination using the destination table, the settings of the reception destination are also deleted, so they must be registered again. When a destination is changed, a message is transmitted to the new destination. If there is no destination of the specified type, you can set a certain destination to be priority quoted. See p.166 “User Parameters” (switch 32, bit 0).

### 1 Press the [User Tools/Counter] key.

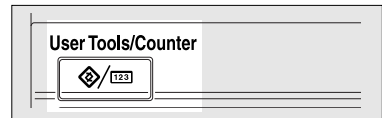

ZFLS110N

### 2 Press [Facsimile Features].

### 3 Press [Administrator Tools].

### 4 Press [Box Setting].

### 5 Check that Select [Program / Change] is selected.

### 6 Select the box to program.

When programming a new box, press [\* Not Programed].

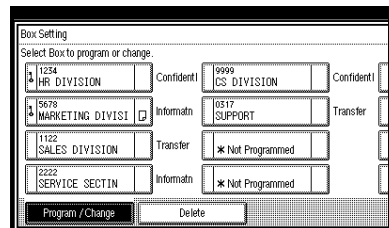

#### Note

- To change a box already programmed, press it, and then proceed to step 9.

### 7 Press [Transfer Box].

**8** Enter a Box name, and then press [OK].

**Reference**

“Entering Text”, *General Settings Guide*

**9** Enter a SUB Code.

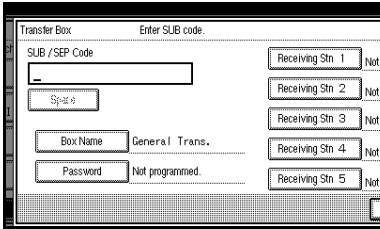

**Note**

- To change the SUB Code, press [Clear] or the [Clear/Stop] key, and then try again. To change Box name, press [Box Name], and then repeat from step 8.

**10** Specify the condition of registration.

Programming End Receivers

**1** Select an End Receiver.

**Note**

- You can store five End Receivers.

**2** Specify End Receivers with Quick Dials, and then press [OK].

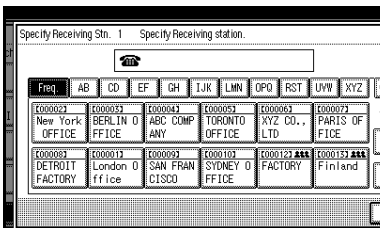

**Note**

- You can change the display to the fax destination, Internet fax destination, and IP-Fax destination using the button on the right side of the display.

- A reception station can also be registered as a group destination. In such a case, a maximum of 500 parties including End Receivers 1-5 can be specified in a group.

To register another End Receivers, repeat the procedure from step 1.

Programming a password

If you do not want to program a password, proceed to step 11.

- Press [Password].
- Enter a password, and then press [OK].

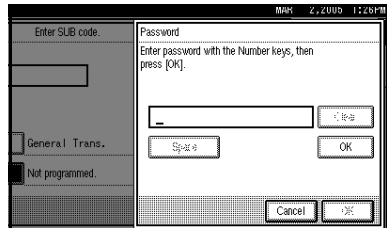

**Note**

- If you make a mistake, press [Clear] or the [Clear/Stop] key before pressing [OK], and then try again.

- 3** Re-enter the password, and then press **[OK]**.

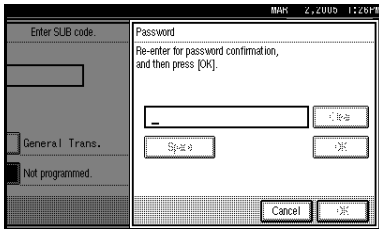

**Note**

- If you make a mistake, press **[Clear]** or the **[Clear/Stop]** key before pressing **[OK]**, and then try again.
- To change the password after pressing **[OK]**, press **[Change]** and repeat steps **2** and **3**, or press **[Cancel]** and repeat the procedure from step **1**.

- 4** Press **[OK]**.

- 11** Press **[OK]**.

- 12** Press **[Exit]**.

- 13** Press the **[User Tools/Counter]** key.  
The standby display appears.

### Deleting Transfer Boxes

- 1** Press the **[User Tools/Counter]** key.

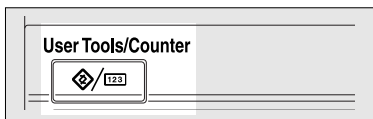

- 2** Press **[Facsimile Features]**.

- 3** Press **[Administrator Tools]**.

- 4** Press **[Box Setting]**.

- 5** Press **[Delete]**, and then select the box you want to delete.

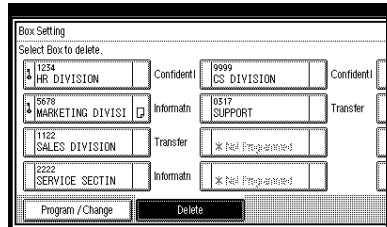

### With a programmed password

- 1** Enter a password using the number keys, and then press **[OK]**.

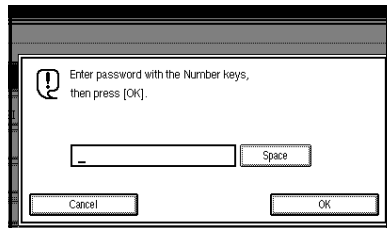

**Note**

- If you make a mistake, press **[Clear]** or the **[Clear/Stop]** key.

- 6** Press **[Delete]**.

**Note**

- To cancel deleting a special sender, press **[Do not Delete]**. The display returns to that of step **5**.

- 7** Press **[Exit]**.

- 8** Press the **[User Tools/Counter]** key.  
The standby display appears.

## Printing the Box List

Follow the procedure below to print a list showing the currently programmed Personal Boxes, Information Boxes, and Transfer Boxes.

- 1 Press the **[User Tools/Counter]** key.

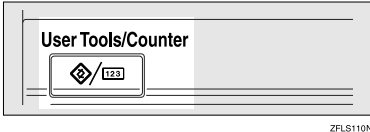

- 2 Press **[Facsimile Features]**.

- 3 Press **[Administrator Tools]**.

- 4 Press **[Print List]** next to "Box Setting".

- 5 Press the **[Start]** key.

After printing the list, you can then start from step 4.

### Note

- To cancel printing a list before pressing the **[Start]** key, press **[Cancel]** or the **[Clear/Stop]** key. The display returns to that of step 4.
- To cancel printing a list after pressing the **[Start]** key, press **[Stop Printing]**. The display returns to that of step 4.

- 6 Press the **[User Tools/Counter]** key. The standby display appears.

## Transfer Report

For the Requesting Party to be able to receive Transfer Result Reports from the Transfer Station, the Requesting Party must program the number of the telephone line in connection on their own machine. See p.52 "Transfer Request".

Be sure to insert a pause after the area code.

For example, if you are in the United States and your fax number is 212-1234567, program the following:

- 1212-1234567

You can program the fax number for the G3 line.

### Limitation

- You cannot program or edit a Transfer Report when using a line (during communication). Program or edit after communication.

### Note

- You cannot use Transfer Request if the telephone number of their machine is not programmed into that machine.
- Up to 16 digits are available for G3.

- 1 Press the **[User Tools/Counter]** key.

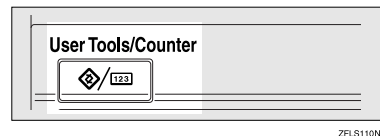

- 2 Press **[Facsimile Features]**.

- 3 Press **[Administrator Tools]**.

- 4 Press **[Transfer Report]**.



## 5 Specify the fax number.

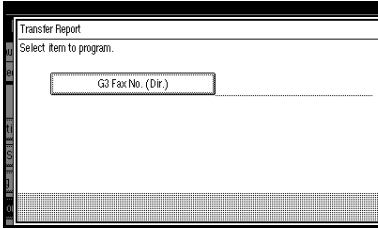

### Programming a G3 Fax Number

- 1 Press **[G3 Fax No. (Dir.)]**.
- 2 Enter your facsimile number using the number keys, and then press **[OK]**.

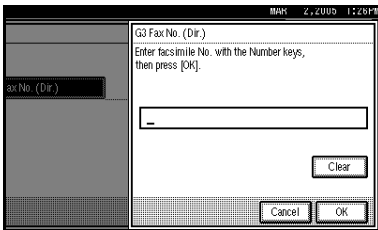

#### Note

- If you make a mistake, press **[Clear]** or the **[Clear/Stop]** key.

## 6 Press **[Exit]**.

## 7 Press the **[User Tools/Counter]** key.

The standby display appears.

## Programming a Confidential ID

Program a Confidential ID to print a Confidential Reception. See p.36 "Printing a Confidential Message".

#### Note

- If you do not program a Confidential ID, you cannot receive a Confidential Transmission.

## 1 Press the **[User Tools/Counter]** key.

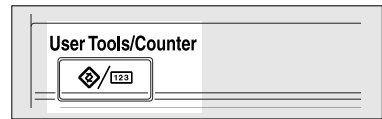

ZFLS110N

## 2 Press **[Facsimile Features]**.

## 3 Press **[Administrator Tools]**.

## 4 Press **[Program Confidential ID]**.

## 5 Enter an ID using the number keys, and then press **[OK]**.

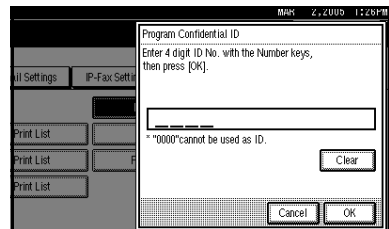

#### Note

- A Confidential ID can be any four-digit number, except 0000.
- If you make a mistake, press **[Clear]** or the **[Clear/Stop]** key before pressing **[OK]**, and then try again.

To cancel programming an ID, press **[Cancel]**. The display returns to that of step 4.

## 6 Press the **[User Tools/Counter]** key.

The standby display appears.

## Programming a Polling ID

Program a Polling ID to use the Transfer Request, Transfer Station, Default ID Polling Transmission, and Default ID Polling Reception functions. When you use ID Transmission, program the same ID as the one programmed on the sender's machine.

### Reference

- p.11 "Polling Transmission"
- p.14 "Polling Reception"
- p.52 "Transfer Request"
- p.75 "Selecting transmission options for a single transmission"

**1** Press the **[User Tools/Counter]** key.

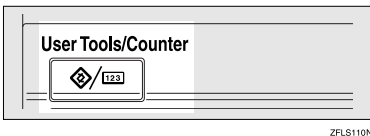

ZFLS110N

**2** Press **[Facsimile Features]**.

**3** Press **[Administrator Tools]**.

**4** Press **[Program Polling ID]**.

**5** Enter an ID using the number keys and **[A]** to **[F]**, and then press **[OK]**.

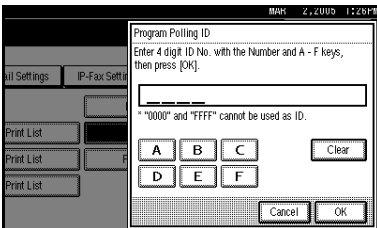

### Note

- Register a four-digit number using 0 through 9 and A through F (except for 0000 and FFFF).

- If you make a mistake, press **[Clear]** or the **[Clear/Stop]** key before pressing **[OK]**, and then try again.

- To cancel programming an ID, press **[Cancel]**. The display returns to that of step **4**.

**6** Press the **[User Tools/Counter]** key.

The standby display appears.

## Programming a Memory Lock ID

Program a Memory Lock ID to be entered before printing documents when the Memory Lock function is activated.

**1** Press the **[User Tools/Counter]** key.

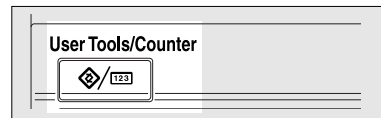

ZFLS110N

**2** Press **[Facsimile Features]**.

**3** Press **[Administrator Tools]**.

**4** Press **[Program Memory Lock ID]**.

**5** Enter an ID using the number keys, and then press **[OK]**.

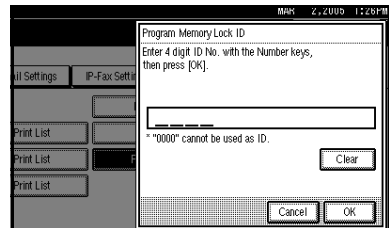

### Note

- A Memory Lock ID can be any four-digit number, except 0000.

- ❑ If you make a mistake, press **[Clear]** or the **[Clear/Stop]** key before pressing **[OK]**, and then try again.
- ❑ To cancel programming an ID, press **[Cancel]**. The display returns to that of step **4**.

- 6** Press the **[User Tools/Counter]** key.  
The standby display appears.

## Selecting Dial/Push Phone

Use this function to select a line type when the machine is connected to a G3 analog line.

Dial and Push lines are available for selection.

### Note

- ❑ When the optional G3 expansion unit is installed, "G3-2" appears.
- ❑ This function is not available in some areas.

- 1** Press the **[User Tools/Counter]** key.

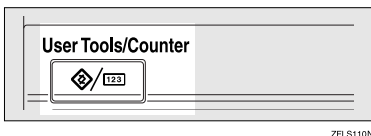

- 2** Press **[Facsimile Features]**.

- 3** Press **[Administrator Tools]**.

- 4** Press **[Select Dial / Push Phone]**.

- 5** Press **[Push Button Phone]** or **[Dial Phone (10PPS)]** to select the line, and then press **[OK]**.

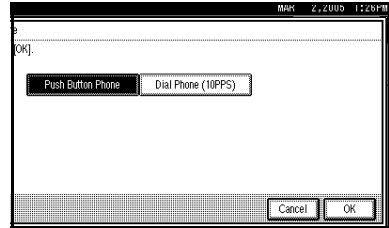

### Reference

p.202 "Selecting the Line Type"

- 6** Press the **[User Tools/Counter]** key.  
The standby display appears.

## Storing or Printing Received Documents

Specify whether received documents are to be saved on the hard disk or printed immediately without being saved. You can print stored documents repeatedly or download them as images to a computer using a Web Image Monitor or DeskTopBinder. If you select printing without saving, documents are printed each time they are received.

### Limitation

- ❑ If using System Settings you have set the machine to distribute received faxes to the delivery server, the documents cannot be saved on the hard disk.

### Note

- ❑ You can use "User Parameters" (switch 10, bit 5) to set whether or not to print stored received document. See p.166 "User Parameters".

- ❑ If the facsimile is set to store received documents, document reception can be notified to a specified e-mail address.
  - ❑ Documents saved on the hard disk are categorized as received and stored documents. For details about printing saved documents, see p.34 “Printing/Deleting Received and Stored Documents (Print/Delete Stored RX File)”.
  - ❑ You cannot switch the setting if received documents have been stored on the hard disk. To switch the setting, print documents stored on the hard disk if necessary, and then delete them.
  - ❑ Received confidential messages are stored in memory. Use the Print Confidential RX File function to print them.
  - ❑ With **[Store]** selected, more memory space will be used as the number of saved documents increase. After memory space becomes insufficient, no more documents are saved on the hard disk. If this happens, the machine will start printing and deleting saved documents with the oldest one.
  - ❑ You can store received documents up to a total of approximately 320 pages or 2,240 (when the optional expansion memory is installed) of A4 size Standard <ITU-T#4Chart>.
  - ❑ You cannot send received documents.
  - ❑ You cannot manage documents stored on the Document Server display.
- 1** Press the **[User Tools/Counter]** key.

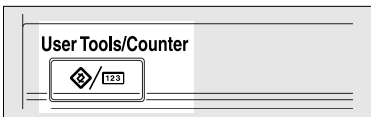

ZFLS110N

- 2** Press **[Facsimile Features]**.
- 3** Press **[Administrator Tools]**.
- 4** Press **[Reception File Setting]**.
- 5** Select **[Print]** or **[Store]**, and then press **[OK]**.

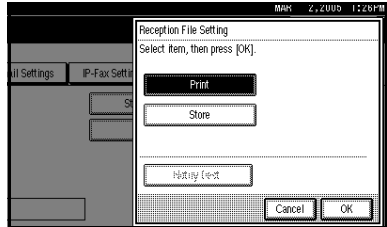

**Note**

- ❑ To cancel your selection, press **[Cancel]**. The display returns to that of step **4**.
- ❑ When **[Store]** is selected, you can select whether or not to send notice of reception to a specific e-mail address. To notify of reception, press **[Notify Dest.]** and select an e-mail address from the Internet Fax destinations programmed in the address book. Further, you can register a group destination. In such a case, a maximum of 500 parties can be specified in a group.

- 6** Press the **[User Tools/Counter]** key. The standby display appears.

---

**Reception Report e-mail**

---

When a received document is stored, this report is sent to the e-mail address set as the destination for notification.

## Setting a User for Viewing Received and Stored Documents

The administrator can be specified for managing documents stored on the machine after fax messages are received. To specify the administrator, enter the administrator user code for managing documents using Web Image Monitor or DeskTopBinder Lite/Professional.

### Preparation

You must register the administrator's User Code to the destination table in advance. See "Authentication Information", *General Settings Guide*

### Note

- This function is only available when received documents are saved on the hard disk. See p.193 "Storing or Printing Received Documents".
- If the programmed user code has been deleted using the Address Book Management function under System Settings, you cannot view received and saved documents using a Web Image Monitor. Select **[Off]** in step **5** or reprogram a user code.
- If the specified user is deleted from the address book, a message "deleted from address book" will appear. Specify the user again from the start.

### **1** Press the **[User Tools/Counter]** key.

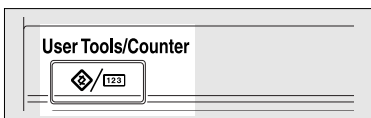

ZFLS110N

### **2** Press **[Facsimile Features]**.

### **3** Press **[Administrator Tools]**.

### **4** Press **[Stored RX File User Setting]**.

### **5** If you want to use a user code, press **[On]**.

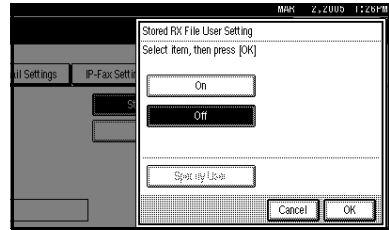

### Note

- If you do not want to use a user code, press **[Off]** and proceed to step **6**.
- To cancel the selection, press **[Cancel]**. The display returns to that of step **4**.

### **6** Press the destination key of the user you wish to specify, and then press **[OK]**.

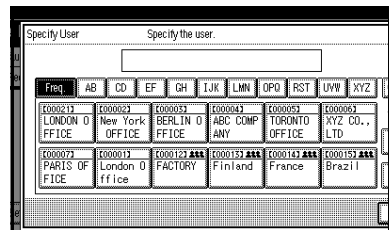

### **7** Check the selected user, and then press **[OK]**.

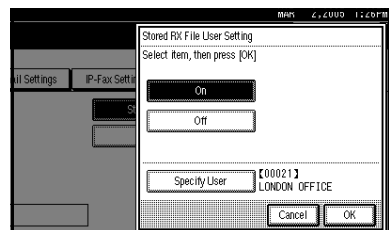

 **Note**

- When a programmed user is deleted from the destination list, a message “Deleted from Address Book” is displayed. Re-enter the user.

**8** Press [OK].

**9** Press the **[User Tools/Counter]** key.

The standby display appears.

---

## Menu Protection Settings

---

You can set up user access rights for functions that users other than administrators can set. For details description, ask the administrator.

# 10. Solving Operation Problems

## When an Error Report is Printed

An Error Report is printed if a message cannot be successfully sent or received.

Possible causes include a problem with your machine or noise on the telephone line. If an error occurs during transmission, resend the original. If an error occurs during reception, ask the sender to resend the message.

### **Note**

- If an error happens frequently, contact your service representative.
- The "Page" column gives the total number of pages. The "Page Not Sent" column gives the number of pages not sent or received successfully.
- You can display a destination with the User Parameters. See p.166 "User Parameters" (switch 04, bit 4).
- You can display a sender name with the User Parameters. See p.166 "User Parameters" (switch 04, bit 5).

# Turning Off the Main Power / When a Power Failure Occurs

**⚠ CAUTION:**

- *When you disconnect the power plug from the wall outlet, always pull the plug (not the cable).*

Even if the main power switch is turned off, the contents of the machine memory (for example, programmed numbers) will not be lost. However, if power is lost for about one hour because the main power switch is turned off, there is a power cut, or the power cable is removed, contents of the Fax memory will be lost. Lost items will include any fax messages stored in memory using Memory Transmission/Reception, Auto Document, Confidential Reception, Memory Lock, or Substitute Reception.

If a file has been deleted from memory, a Power Failure Report is automatically printed as soon as the power is restored. This report can be used to identify lost files. If a memory stored for Memory Transmission was lost, resend it. If a message received by Memory Reception or Substitute Reception was lost, ask the sender to resend it.

**⚡ Important**

- ❑ Do not turn off the main power switch while the power indicator is lit or blinking. If you do, the hard disk and memory may be damaged and failure could result.
- ❑ Turn off the main power switch before pulling out the plug. If you pull out the plug with the switch on, the hard disk and memory may be damaged and failure could result.

- ❑ Make sure that 100% is shown on the display before you unplug the machine. If a lower value is shown, some data is currently present in memory.
- ❑ Right after a power failure, the internal battery needs to be sufficiently recharged to guard against future data loss. Keep the machine plugged in and the main power switch on for about one week after the power loss.

**💡 RDS (Remote Diagnostic System)**

If your machine has a problem, a service representative can perform various settings over the telephone line from the service station.

If you want to use this function, change the User Parameter. See p.166 "User Parameters" (switch 25, bit 4).



---

# When an Error Occurs Using Internet Fax

---

---

## Error Mail Notification

---

The machine sends the Error Mail Notification to the sender when it is unable to successfully receive a particular e-mail message. A "cc" of this notification is also sent to the administrator's e-mail address when one is specified.

 **Note**

- You can select to send Error Mail Notification with User Parameters. See p.166 "User Parameters" (switch 21, bit 7).
- If Error Mail Notification cannot be sent, the Error Report (E-Mail) is printed by the machine.
- If an error occurs when an e-mail is received via SMTP, the SMTP server sends an error e-mail to the originator of the message.

---

## Error Report (E-Mail)

---

The Error Report (E-Mail) is printed by the machine when it is unable to send an Error Mail Notification.

---

## Server-Generated Error E-mail

---

The transmitting server sends this error e-mail to the originator of e-mail that cannot be transmitted successfully (due to reasons such as specifying an incorrect e-mail address).

 **Note**

- After a server-generated error e-mail is printed, the first page of the sent document is printed.



## Connecting the Machine to a Telephone Line and Telephone

### Connecting the Telephone Line

To connect the machine to a telephone line, use a snap-in modular type connector.

#### **Important**

☐ Make sure the connector is the correct type before you start.

#### ◆ Where to connect the machine

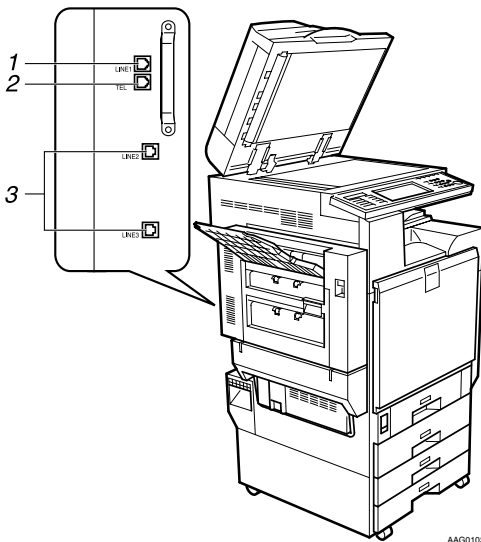

AAG010S

1. G3 interface unit connector
2. External telephone connector
3. Extra G3 interface unit connector

---

## Selecting the Line Type

---

Select the line type to which the machine is connected. There are two types: tone and pulse dial.

 **Note**

- This function is not available in some areas.

Select the line type using “Administrator Settings”. See p.193 “Selecting Dial/ Push Phone”.

---

## Connecting the Optional Handset or an External Telephone

---

You can connect the optional handset or an external telephone to the machine. You can use it for telephone calls.

 **Note**

- Some external telephones may not be connected or may suffer reduced functionality.

 **Limitation**

- When you use the optional handset or an external telephone with the **[On Hook Dial]** key for telephone calls, you can not talk with the other party without pressing the **[On Hook Dial]** key after taking off the receiver.

◆ **Specifying the handset line type**

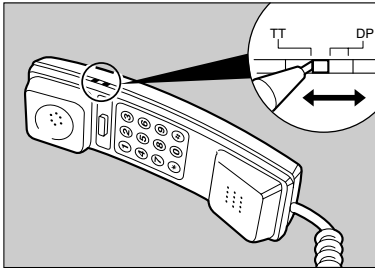

The switch on the handset should be in the appropriate position-TT (Tone Dialing) or DP (Pulse Dialing).

◆ **Adjusting the handset bell volume**

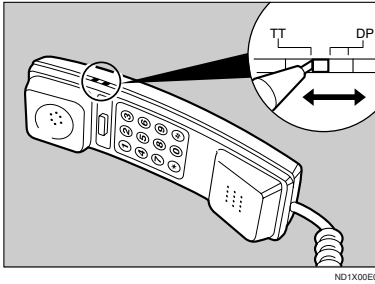

Adjust the handset ringer volume using the volume switch.

# Optional Equipment

---

## Expansion Memory (32MB: DIMM)

---

This allows you to send fax messages at high resolution (Super Fine). This also allows you to receive fax messages at high resolution (Fine or Super Fine). If you require this option, consult your service representative. See p.212 “Maximum Values”.

---

## Handset

---

You can make or receive calls by installing the optional handset and dialing manually.



**Reference**

p.58 “Manual Dial”

---

## Extra G3 Interface Unit

---

This option provides one extra G3 line connection.

A maximum of two G3 interface unit can be installed.

# Specifications

## ◆ Fax Transmission and Reception

Standard	G3
Resolution	G3: 8 × 3.85/mm-200 × 100dpi (Standard character), 8 × 7.7/mm-200 × 200dpi (Detail character), 8 × 15.4/mm (Fine character: optional expansion memory required), 16 × 15.4/mm-400 × 400dpi (Super Fine character: optional expansion memory required)
Transmission time	G3: 3 seconds at 28,800 bps, Standard resolution (JBIG transmission: 2 seconds)
Data compression method	MH, MR, MMR, JBIG
Maximum original size	Standard size: A3, 11" × 17"
Maximum scanning size	Standard size: 297 × 432mm/11" × 17" Irregular size: 297 × 1,200mm/11" × 47"
Print process	Printing on standard paper using a laser
Transmission speed	G3: 33,600/31,200/28,800/26,400/24,000/21,600/19,200/16,800/14,400/12,000/9,600/7,200/4,800/2,400bps (auto shift down system)

## ◆ Power Consumption

Standby mode	approx. 250 W
Low power mode	approx. 140 W
Sleep mode	19 W or less
Immediate Transmission	approx. 270 W
Memory Transmission	approx. 260 W
Memory Reception	approx. 260 W
Reception	approx. 760 W
Maximum power consumption	1,500 W or less

◆ Internet Fax Transmission and Reception

Network	LAN : Local Area Network Ethernet/10Base-T, 100Base-TX, IEEE1394 (IP over 1394), IEEE802.11b (wireless LAN)
Transmit function	E-mail
Scan line density	200 × 100dpi (Standard character), 200 × 200dpi (Detail character), 200 × 400dpi (Fine character: optional) *1, 400 × 400dpi (Super Fine character: optional) *1
Original size : Scanning width	A3 *1, B4 *1, A4
Communication Protocols	<ul style="list-style-type: none"> <li>• Transmission SMTP, TCP/IP</li> <li>• Reception POP3, SMTP, IMAP4, TCP/IP</li> </ul>
E-mail format	Single/Multi-part, MIME Conversion Attached file forms: TIFF-F (MH, MR *1, MMR *1 compression)
Authentication method	SMTP-AUTH, POP before SMTP, A-POP
Internet communication	Send and receive e-mail with a computer that has an e-mail address
E-mail send functions	Automatic conversion of sent documents to e-mail format and e-mail transmission. Memory transmission only.
E-mail receive functions	Automatic detection and printing of appended TIFF-F (MH) files and ASCII text. Memory reception only.

\*1 Full mode



## ◆ IP-Fax Transmission and Reception

Network	LAN: Local Area Network Ethernet/10base-T, 100base-TX, IEEE1394 (IP over 1394), IEEE802.11b (wireless LAN)
Scan line density	8 × 3.85mm-200 × 100dpi (Standard character), 8 × 7.7mm, 200 × 200dpi (Detail character), 8 × 15.4mm (Fine character: optional expansion memory required), 16 × 15.4mm, 400 × 400dpi (Super Fine character: optional expansion memory required)
Original size	Maximum A3 or 11" × 17" (DLT)
Maximum scanning size	Standard: A3, 297mm × 432mm, Irregular: 297mm × 1200mm
Transmission protocol	Recommended: T.38 Annex, TCP, UDP/IP communication
Compatible machines	IP-Fax compatible machines
IP-Fax transmission function	Specify IP address and send fax to an IP-Fax compatible fax through a network.  Also capable of sending fax from a G3 fax connected to telephone lines via a VoIP gateway.
IP-Fax reception function	Receive a fax sent from an IP-Fax compatible fax through a network.  Also capable of receiving fax from a G3 fax connected to telephone lines via a VoIP gateway.

## Compatible Machines

This machine is compatible to machines having the following specifications.









Communication protocols	<ul style="list-style-type: none"> <li>• Transmission SMTP</li> <li>• Reception POP3, SMTP, IMAP4</li> </ul>
E-mail format	<ul style="list-style-type: none"> <li>• Format MINE, Base64</li> <li>• Content-Type Image/tiff Multipart/mixed (text/plain, Image/tiff (attached file forms))</li> </ul>
Data format	<ul style="list-style-type: none"> <li>• Profile TIFF Profile S</li> <li>• Coding MH, MR <sup>*1</sup>, MMR <sup>*1</sup></li> <li>• Original size A3 <sup>*1</sup>, A4, B4 <sup>*1</sup>, 8<sup>1</sup>/<sub>2</sub>"×11" <sup>*1</sup>, 8<sup>1</sup>/<sub>2</sub>"×14" <sup>*1</sup></li> <li>• Resolution (dpi) 200×100/200×200, 204×98/204×196, 200×400 or 400×400</li> </ul>

<sup>\*1</sup> Available in full mode, depending on the other party's settings.

## Acceptable Types of Originals

Make sure your originals are completely dry before setting them in the machine. Wet ink or correcting fluid from originals will mark the exposure glass and affect the resulting image.

### Acceptable original sizes

Where original is set	Acceptable original size	Maximum number of sheets	Paper thickness
Exposure glass	Up to A3 (297 × 420mm), 11" × 17" (279 × 432mm)	1	---
ADF, one-sided document	Fax transmission: A5  to A3  (up to 1,200mm long) 8" × 5 <sup>1</sup> / <sub>2</sub> "  to 11" × 17" 	80 sheets (80 g/m <sup>2</sup> , 20 lb)	40-128 g/m <sup>2</sup> (11-34 lb)
ADF, two-sided document	Fax transmission: A5  to A3  (up to 432mm long) 8" × 5 <sup>1</sup> / <sub>2</sub> "  to 11" × 17" 	80 sheets (80 g/m <sup>2</sup> , 20 lb)	52-105 g/m <sup>2</sup> (14-28 lb)

### Paper size and scanned area

#### ◆ Exposure Glass

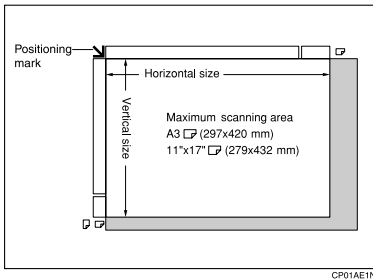

#### ◆ ADF

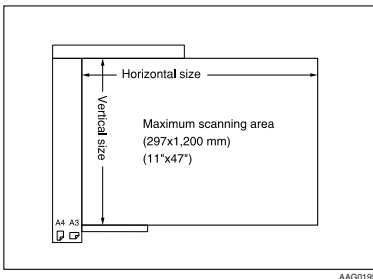

### 🔊 Limitation

- ❑ There may be a difference in the size of the image when it is printed at the destination.
- ❑ If you place an original larger than A3, 11"×17" on the exposure glass, only an A3, 11"×17" area is scanned.

### 📝 Note

- ❑ Even if an original is correctly placed on the exposure glass or in the ADF, a margin of 3mm (0.1") around each edge of the original may not be sent.
- ❑ If the receiver uses paper of a smaller width than the original, the image will be reduced to fit that paper. See p.74 "Auto Reduce".
- ❑ The machine detects paper sizes in the following ways:
  - When you place an original in the ADF, an original wider than about 264mm (10.4") is scanned as A3, 11" × 17" size.  
An original narrower than about 230mm (9.1") will be sent as 8<sup>1</sup>/<sub>2</sub>" × 11" or 8<sup>1</sup>/<sub>2</sub>" × 14" size, and an original narrower than about 264mm (10.4") is scanned as B4 JIS.
  - Originals up to 1,200mm (47.2") in length can be scanned.
  - Refer to the table below for sizes the machine can detect when you place an original on the exposure glass. Because the machine scans non-standard size documents in a standard size, part of the image may be truncated depending on the length of the document. For details about how to set non-standard size documents, see p.15 "Setting a Scan Area", *Facsimile Reference* <Basic Features>.

### ❖ Metric Version

		Length *1			
		-approx. 249mm	approx. 249mm- approx. 274mm	approx. 274mm- approx. 316mm	approx. 316mm-
Width	-approx. 243mm	×	B5 JIS📄	A4📄	F📄
	approx. 243mm- approx. 268mm	B5 JIS📄	B4 JIS📄	B4 JIS📄	B4 JIS📄
	approx. 268mm-	A4📄	A3📄	A3📄	A3📄

◆ **Inch Version**

		Length *1			
		-approx. 9.8"	approx. 9.8"-approx. 10.8"	approx. 10.8"-approx. 12.4"	approx. 12.4"-
Width	-approx. 9.6"	×	×	8 <sup>1</sup> / <sub>2</sub> "×11"☐	F☐
	approx. 9.6" - approx. 10.6"	11"×8 <sup>1</sup> / <sub>2</sub> "☐	11"×17"☐	11"×17"☐	11"×17"☐
	approx. 10.6"-	11"×8 <sup>1</sup> / <sub>2</sub> "☐	11"×17"☐	11"×17"☐	11"×17"☐

× - Unable to auto detect

\*1 Normally a length of about 420mm (16.5") can be scanned; however, it is only possible to specify a scanning size up to 432mm (17").

 **Maximum scan area**

The maximum scan area is shown below:

- Memory Transmission: 297 × 1,200mm/11" × 47" (W × L) from the ADF
- Immediate Transmission: 297 × 1,200mm/11" × 47" (W × L) from the ADF

 **Note**

- ☐ During Immediate Transmission, the length of the scanning range can become narrower than 1,200mm (47"), depending on the character size as well as the settings on the destination machine.
- 297 × 432mm/11" × 17" (W × L) (from the exposure glass)

---

## Original sizes difficult to detect









---

The machine has difficulty detecting the size of the following kinds of originals. (When this happens, the receiving machine may not select print paper of the correct size.)

- documents placed on the exposure glass of sizes other than those listed in the table below
- originals with index tabs, tags, or protruding parts
- transparent originals, such as OHP transparencies or translucent paper
- dark originals with dense text or drawings
- originals that contain areas of solid print
- originals that have solid print around their edges
- originals with glossy surfaces
- bound originals of more than 10mm (0.3") in thickness, such as books.

The following paper sizes are automatically detected in facsimile mode.





◆ **Metric Version**

Paper size where original is placed	A3 	8 1/2"×13" (F4)	B4 JIS 	A4  	B5 JIS  	A5  
Exposure glass	<input type="radio"/>	<input type="radio"/>	<input type="radio"/>	<input type="radio"/>	<input type="radio"/>	×
ADF	<input type="radio"/>	<input type="radio"/>	<input type="radio"/>	<input type="radio"/>	<input type="radio"/>	<input type="radio"/>

- Auto detect

× - Unable to auto detect

◆ **Inch Version**

Paper size where original is placed	11"×17" 	8 1/2"×14" 	8 1/2"×11"  	5 1/2"×8 1/2" 
Exposure glass	<input type="radio"/>	<input type="radio"/>	<input type="radio"/>	×
ADF	<input type="radio"/>	<input type="radio"/>	<input type="radio"/>	<input type="radio"/>

- Auto detect

× - Unable to auto detect

# Maximum Values

The following list contains the maximum value for each item.

## Note

- The maximum number of pages that can be stored or transmitted may decrease depending on the contents of documents.

Item	Standard	Expansion memory (Optional)
Memory (with optional)	4 MB	28 MB
The number of pages that you can store in memory (Using A4 size Standard <ITU-T #4Chart> )	Approx. 320	Approx. 2,240
Total number of all documents	400	400
The number of pages per file	1,000	1,000
The number of pages for all files	1,000	3,000
The number of destinations you can specify for one file	500	500
The number of destinations you can specify for all files	500	500
The number of Quick Dials you can program	2,000	2,000
The number of Group Dials you can program	100	100
The number of destinations you can program in a group	500	500
The number of digits for Dials	128	128
The number of Programs you can register	100	100
The number of Auto Documents you can program	6	6
The number of Standard Message Stamps you can program	3	3
The number of transmission records the machine can store	200	200
The number of stored documents you can specify at one time	1,000	1,000
The number of stored documents you can send at one time	30	30
The number of pages that you can store in the Document Server (Using ITU-T #4Chart)	Approx. 9,000	Approx. 9,000
The number of pages you can store in the Document Server for one document	1,000	1,000

<sup>\*1</sup> This indicates the number of transmission records that you can check using Smart-DeviceMonitor for Admin. From the machine you can check up to 400 communication records (transmission plus reception).

# INDEX

---

180-Degree Rotation Printing, 98  
2 Sided Printing, 97

## A

---

Address Book, 118  
Administrator Settings, 155  
Administrator Tools List, 155  
Authorized Reception, 172  
Auto Document, 65, 158  
    *Changing*, 158  
    *Deleting*, 159  
    *Sending*, 65  
    *Storing*, 158  
Auto Fax Reception Power-up, 95  
Automatic Redial, 78  
Auto Reduce, 74

## B

---

Basic Transmission, 112  
Batch Transmission, 78  
Book Fax, 61  
Box Setting, 156, 180

## C

---

Canceling  
    *Transmission*, 19  
Center Mark, 96  
Chain Dial, 47  
Checked Mark, 96  
Checking  
    *Transmission Result (TX File Status)*, 31  
Combine 2 originals, 83  
Combine Two originals, 99  
Communication Failure Report, 82  
Communication Information, 27  
Communication Result Report  
    (Memory Transmission), 81  
Confidential File Report, 37  
Confidential ID, 191  
Confidential Message, 36  
Confidential Transmission, 9  
Counters, 155, 162

## D

---

Default ID/Free Polling Reception, 14  
Default ID Transmission, 11, 12, 74  
Deleting  
    *Information Box Messages*, 45  
    *programmed destinations*, 119  
Destination  
    *Adding*, 21  
    *Checking*, 18  
    *Deleting*, 20  
Displaying the Memory Status, 33  
Document Server, 133  
    *Delete File*, 138  
    *Manage File*, 136  
    *Storing a Document*, 134  
Dual Access, 78

## E

---

ECM (Error Correction Mode), 155, 165  
Economy Transmission Time, 3  
E-mail transfer, 94  
E-mail TX Results, 80, 116  
End Receiver, 163  
Error Mail Notification, 199  
Error Report, 197  
Error Report (E-Mail), 199  
Expansion Memory, 204  
Extra G3 Interface Unit, 204

## F

---

Fax Header Print, 73  
Fax via Computer, 107  
File  
    *Printing*, 23  
    *Printing a List of Files*  
        *in Memory (Print TX File List)*, 25  
    *Resending*, 24  
Forwarding, 90, 155, 162, 173  
Free Polling Transmission, 11, 12  
Full/Partial agreement, 171

## G

---

General Settings/Adjustment, 144

## H

---

Handy Dialing Functions, 47

## I

---

- ID Override Polling Reception, 14
- ID Override Transmission, 11
- Image Rotation, 79, 99
- Immediate Reception, 83
- Immediate TX Result Report (Immediate Transmission), 82
- Information Boxes, 42, 185
  - Changing*, 184
  - Deleting*, 185
  - Printing*, 190
  - Programming*, 184
  - Storing Messages*, 42

## J

---

- JBIG, 79, 95
  - Reception*, 95
  - Transmission*, 79
- Journal, 27
- Journal by E-mail, 80
- Journal by E-mail, Transmitting, 80
- Just size printing, 103

## K

---

- Keystroke Program, 129

## L

---

- Label Insertion, 73
- LAN-Fax Operation Messages, 122
- LAN-Fax Properties, Setting, 110
- Line Type
  - Changing*, 59
  - Selecting*, 202

## M

---

- Manual Dial, 58
- Maximum Value, 212
- Memory Lock, 38, 165, 174
- Memory Lock ID, 192
- Memory Reception, 83
- Memory Status, 33
- Memory Storage Report, 81
- More Transmission Functions, 77
- Multi-copy, 83
- Multi-copy Reception, 98
- Multi-port, 59
- Multistep Transfer, 88

## O

---

- On Hook Dial, 56
- Optional Equipment, 204
- Originals, 208
- Output Tray, 105

## P

---

- Page Reduction, 101
- Page Separation and Length Reduction, 100
- Paper Tray, 147
- Parallel Memory Transmission, 77
- Parameter Setting, 155
- Personal Boxes, 40, 181, 183
  - Changing*, 181
  - Deleting*, 183
  - Printing*, 190
  - Programming*, 181
- Polling ID, 192
- Polling Reception, 14
- Polling Reserve Report, 16
- Polling Result Report, 16
- Polling Transmission, 11
- Polling Transmission Clear Report, 13
- Power Failure Report, 198
- Print 2 Sided, 173
- Print Completion Beep, 96
- Printed Report, 81
- Printing
  - Box List*, 190
  - Confidential Message*, 36
  - File Received with Memory Lock*, 38
  - Information Box Messages*, 44
  - Journal*, 27
  - Options*, 96
  - Personal Box Messages*, 41
  - Special Sender List*, 180
- Printing and Saving, 118
- Priority trays, 102
- Programs, 129
  - Changing*, 129
  - Deleting*, 131
  - Registering*, 129
- PWD Code, 51

## Q

---

- Quick Operation key, 146



## R

---

- RDS (Remote Diagnostic System), 198
- Receiving Station, 52, 87
- Reception, 83
  - Reception Features*, 83
  - Reception File Print Quantity*, 173
  - Reception Functions*, 87
  - Reception Reverse Printing*, 174
  - Reception Settings*, 147
  - Reception Time*, 97
- Reception Result (RX File Status), 32
- Redial, 47
- Reduced Image Transmission, 74
- Report, 81
  - Communication Failure Report*, 82
  - Communication Result Report (Memory Transmission)*, 81
  - Error Report*, 197
  - Immediate TX Result Report (Immediate Transmission)*, 82
  - Memory Storage Report*, 81
  - Power Failure Report*, 198
- Requesting Party, 52, 87
- Reverse Order Printing, 83, 100
- RX File Status, 32

## S

---

- Scan Size, 160
  - Changing*, 160
  - Deleting*, 160
  - Programming*, 160
- Scan size
  - Deleting*, 161
- Selecting
  - Dial/Push Phone*, 193
- Send Later, 3
- SEP Code, 50
- Server-Generated Error E-mail, 199
- SID Code, 50
- Simultaneous Broadcast, 79
- SMTP, 93
- SMTP reception, 92
- Special Senders, 171
- Special Senders to Treat Differently, 171
- Specifications, 205
- Stamp, 72
- Standard Messages, 157
  - Deleting*, 158
  - Programming*, 157
- Standard Message Stamp, 64
- SUB Code, 49, 91
- Substitute Reception, 85
- Switches and Bits, 166

## T

---

- Telephone Line, 201
- Transfer Boxes, 189
  - Changing*, 186
  - Deleting*, 189
  - Printing*, 190
  - Programming*, 186
- Transfer Report, 190
- Transfer Request, 52
- Transfer Result Report, 88
- Transfer Result Report (transfer request by e-mail), 89
- Transferring, 91
- Transfer Station, 52, 87
- Transmission Features, 47
- Transmission Mode, 3
- Transmission Options, 73
- Transmission Time
  - Changing*, 22
- Transmission with Image Rotation, 79
- Tray for Lines, 105
- Tray Shift, 105
- TSI Print, 101
- Two-Sided Printing, 97
- Two-Sided Transmission, 62
- TX File, 18
- TX File Status, 31

## U

---

- User Parameter List, 167
- User Parameters, 166

MEMO



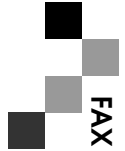

**FAX Option Type 3245 Operating Instructions Facsimile Reference <Advanced Features>**

Printed in Japan  
EN  B712-8511



## Free Manuals Download Website

<http://myh66.com>

<http://usermanuals.us>

<http://www.somanuals.com>

<http://www.4manuals.cc>

<http://www.manual-lib.com>

<http://www.404manual.com>

<http://www.luxmanual.com>

<http://aubethermostatmanual.com>

Golf course search by state

<http://golfingnear.com>

Email search by domain

<http://emailbydomain.com>

Auto manuals search

<http://auto.somanuals.com>

TV manuals search

<http://tv.somanuals.com>