

RED

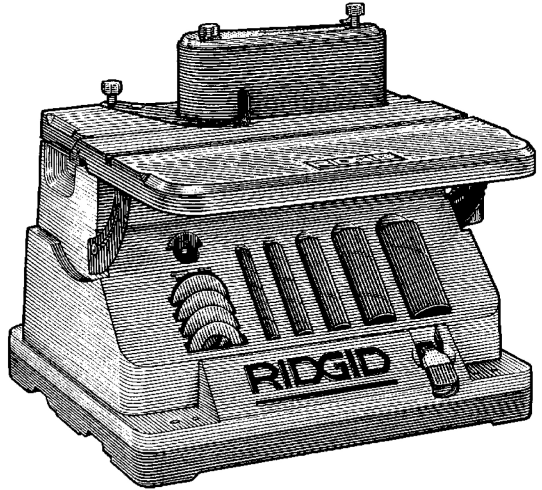

EB4424 OPERATORS MANUAL



OSCILLATING EDGE BELT/SPINDLE SANDER

Call Us 1st

For any questions about:

- **Operation**
- **Warranty** (See back cover)
- **Technical Assistance**
- **Repair Parts**

Please have your Model Number and Serial Number on hand when calling.

1-866-539-1710

RIDGID Parts.com

POWER TOOL PARTS
& ACCESSORIES



WARNING:

Read and follow all Safety Rules before first use of this product.

Table of Contents

Section	Page	Section	Page
Table of Contents	2	Supporting Oscillating Edge Belt/ Spindle Sander to Sawhorses	17
Safety Instructions For Oscillating Edge Belt/ Spindle Sander	3	Alignment	17
Safety Signal Words	3	Squaring Front Table	17
Before Using The Sander	3	Aligning Belt To Miter Gauge Slot	18
When Installing Or Moving The Sander	4	Removing/Installing the Sanding Belt	19
Before Each Use	5	Tensioning and Tracking	19
Plan Ahead To Protect Your Eyes, Hands, Face and Ears	5	Getting to Know Your Spindle Sander	20
When Sander is Running	7	On-Off Switch	21
Before Leaving The Sander	7	Safety Instructions for Oscillating Edge Belt/Spindle Sander	22
Precautions To Take When Sanding Metals	7	Before Using The Sander	22
Precautions To Take When Sanding Paint	7	When Installing Or Moving The Sander	22
Motor Specifications and Electrical Requirements	8	Before Each Use	22
General Electrical Connections	8	Plan Ahead To Protect Your Eyes, Hands, Face and Ears	23
Power Supply and Motor Specifications	8	When Sander is Running	24
110-120 Volt, 60 Hz. Tool Information	9	Before Leaving The Sander	25
Motor Safety Protection	10	Precautions To Take When Sanding Metals	25
Wire Sizes	10	Precautions To Take When Sanding Paint	25
Unpacking and Checking Contents ..	11	Basic Sanding Operation	26
List of Loose Parts	11	Sandpaper Selection	26
Loose Parts	11	Surface Sanding on the Sanding Belt	27
Assembly	12	End Sanding on the Sanding Belt	27
Mounting Rubber Feet To Base	12	Sanding Curved Edges	27
Parts Storage	12	Feed Direction	28
Removing the Sanding Belt Assembly	13	Dust Collection Capability	28
Installing the Sanding Belt Assembly	13	Transporting Sander	28
Installing Sanding Sleeves Larger than 1/2" Diameter	14	Maintenance	29
Installing Sanding Sleeves for the 1/2" Diameter Sanding Drum	15	Lubrication	29
Selection Of Spacer Ring Inserts And Upper Spindle Washers	15	RIDGID Recommends the Following Accessories	29
Bolting Oscillating Edge Belt/Spindle Sander To Workbench	16	Wiring Diagram	29
		Troubleshooting	30
		Repair Parts	32
		Notes	35

Safety Instructions For Oscillating Edge Belt/ Spindle Sander

Safety is a combination of common sense, staying alert and knowing how your oscillating edge belt/spindle sander works. Read this manual to understand this sander.

Safety Signal Words

DANGER: means if the safety information is not followed someone **will** be seriously injured or killed.

WARNING: means if the safety information is not followed someone **could** be seriously injured or killed.

CAUTION: means if the safety information is not followed someone **may** be injured.

Before Using The Sander

WARNING: Some dust created by power sanding, sawing, grinding, drilling, and other construction activities contains chemicals known (to the State of California) to cause cancer, birth defects or other reproductive harm. Some examples of these chemicals are:

- Lead from lead-based paints,
- Crystalline silica from bricks and cement and other masonry products, and
- Arsenic and chromium from chemically-treated lumber.

Your risk from these exposures varies, depending on how often you do this type of work. To reduce your exposure to these chemicals: work in a well ventilated area, and work with approved safety equipment, such as those dust masks that are specially designed to filter out microscopic particles.

WARNING: To reduce the risk of mistakes that could cause serious, permanent injury, do not plug the sander in until the following steps are completed.

- Review and understanding of all safety instructions and operating procedures in this manual.
 - Review of the maintenance methods for this sander. (See page 29)
- Assembly. (See pages 12-19)
 - Learn the use and function of the ON-OFF switch. (See page 21)

Safety Instructions for Oscillating Edge Belt/Spindle Sander (continued)

Read the following WARNING labels found on the sander:

▲WARNING	Do not sand on this side of belt.	▲ADVERTENCIA	No use este lado de la banda para lijar.	▲AVERTISSEMENT	Il ne faut pas poncer avec côté de la bande abrasive
-----------------	-----------------------------------	---------------------	--	-----------------------	--

▲WARNING	▲ADVERTENCIA	▲AVERTISSEMENT
The starting relay in this tool is a gravity sensitive type. Never turn the power on unless the tool is in upright position or the motor will be damaged.	El comenzando reemplazo es un tipo sensible de gravedad. Nunca arrancar el motor a menos que la herramienta este en la posición vertical o el motor se dañara.	Le fonctionnement du relais de démarrage de cet outil est influencé par la gravité. Mettez l'outil en marche seulement s'il est à l'endroit, sans quoi vous risquez d'endommager le moteur.

▲WARNING	▲ADVERTENCIA	▲AVERTISSEMENT
<ol style="list-style-type: none"> 1. Read Manual before using sander. 2. Wear safety goggles that meet ANSI Z87.1 or in Canada CSA Z94.3-99 standards. 3. Wear a dust mask. 4. Keep fingers away from sanding belt or abrasive sleeve when machine is on. 5. Always support workpiece with "backstop", "worktable" or both. 6. Avoid fire. Clean out all sawdust and disconnect from any vacuum before sanding metals. 7. Use the proper insert for each sleeve to minimize pinch points between sleeve and insert. 8. Do not expose to rain or use in damp locations. 	<ol style="list-style-type: none"> 1. Lea el manual antes de usar la lijadora. 2. Use gafas de seguridad que cumplan con las normas ANSI Z87.1 y CSA Z94.3-99. 3. Use una mascarilla antigolpe. 4. Cuando la lijadora está encendida, no acerque los dedos a la banda lijadora ni a la manga abrasiva. 5. Siempre use un tope (crasero, mesa de trabajo o ambos para apoyar la pieza de trabajo). Mantenga un máximo de 1/16 pulgadas (0.15 cm) de espacio entre el tope y la banda de la lijadora. 6. Evite incendios. Antes de lijar metales, limpie el sawdust por completo y, de estar la lijadora conectada a una aspiradora, desconéctela. 7. Con el fin de minimizar los puntos de presión entre la manga y la pieza de inserción, use la pieza de inserción adecuada para cada manga. 8. No exponer a la lluvia ni usar en lugares húmedos. 	<ol style="list-style-type: none"> 1. Lire le manuel avant d'utiliser la ponceuse. 2. Porter des lunettes de protection conformes à la norme CSA Z94.3-99. 3. Porter un masque anti-goutte. 4. Maintenir les doigts à l'écart de la bande de ponçage ou du manchon abrasif quand la machine est en marche. 5. Toujours maintenir en place la pièce avec des têtes, un plateau porte-pièce ou les deux. Maintenir un dégagement maximal de 1/16 po (1.56 mm) entre la bûche arrière et la courroie de ponçage. 6. Nettoyer toute la saure et débrancher tout système d'aspiration avant de poncer des métaux. Afin d'éviter les incendies. 7. Utiliser l'adaptateur approprié pour chaque manchon afin de minimiser les points de pincement entre le manchon et l'adaptateur. 8. Ne pas exposer pas l'outil à la pluie et ne l'utiliser pas dans un endroit humide.

Electrical: 120 volts 60 Hz AC only 5.0 Amps
Covered by U.S. Patent No.'s. 5,548,587 and 6,943,621



When Installing Or Moving The Sander

Avoid dangerous environment.

Use the sander in a dry, indoor place protected from rain. Keep work area well lighted.

To reduce the risk of burns or other fire damage, never use the sander near flammable liquids, vapors or gasses.

To reduce the risk of injury or death from electrical shock:

- Ground the sander. This sander has an approved 3-conductor cord and a 3-prong grounding type plug. Use only 3-wire, grounded outlets rated 120 volts, 15 amperes (amps). The green conductor in the cord is the grounding wire. To reduce the risk of electrocution, **Never** connect the green wire to a live terminal.
- Make sure your fingers do not touch the plug's metal prongs when plugging or unplugging the sander.
- Never use this or any power sander for wet sanding. Doing so could

cause electrocution, serious injury or worse.

To reduce the risk of injury from unexpected sander movement:

- Always unplug the sander before moving it.
- Put the sander on a firm level surface where there is plenty of room for handling and properly supporting the workpiece.
- Attach rubber feet.
- Support the sander so it does not rock.
- Bolt the sander to its work surface. Use the fasteners and method shown in "Assembly." (See page 16.)
- **Never stand on tool.** Serious injury could occur if the tool tips. Do not store anything above or near the tool where anyone might stand on the tool to reach it.

Before Each Use

Inspect your sander. Check for:

- alignment of moving parts,
 - binding of moving parts,
 - broken or damaged parts,
 - work parts that cause a gap larger than 1/16" between work support and sanding surface,
 - sanding belt narrower than 4 inches. Narrower belts uncover parts that could trap your fingers,
 - worn or damaged electric cords,
 - stable mounting, and
 - any other conditions that may affect the way the sander works.
- Remove adjusting keys and wrenches. Form a habit of checking for and removing keys and adjusting wrenches from table top before turning sander on.

If any part is missing, bent, or broken in any way, or any electrical parts don't work properly, turn the sander off and unplug the sander. **Replace** damaged, missing, or failed parts before using the sander again.

Disconnect the sander to reduce the risk of injury from accidental starting. Turn switch off, unplug sander and remove the switch key before changing the setup or sanding drum.

Maintain tools with care. Keep the sander clean for maximum and safest performance.

To reduce the risk of injury from jams, slips or thrown pieces:

- **Use only recommended accessories.**
- **Use the correct spacer ring insert.** The opening between the sanding sleeve and insert must be 5/32 of an inch or less. (See page 15)
- **All sanding drums, washers and knobs are tight.** No parts should have excessive play prior to operating unit.
- **Keep work area clean.** Cluttered work surfaces invite accidents. Floor must be clean and dry for stable footing.

Plan Ahead To Protect Your Eyes, Hands, Face and Ears

Dress for Safety

- Any power sander can throw foreign objects into the eyes. This can result in permanent eye damage. Always wear safety goggles, not glasses complying with ANSI Z87.1 (or in Canada CSA Z94.3-99) shown on package. Everyday eyeglasses have only impact resistant lenses. They are not safety glasses. Safety goggles are available at many local retail stores. Glasses or goggles not in compliance with ANSI or CSA could seriously hurt you when they break.



- Sanding operations are usually dusty. Wear a dust mask along with the safety goggles.
- Wear nonslip footwear.
- Tie back long hair.
- Roll long sleeves above the elbow.
- Noise levels vary widely. To reduce the risk of possible hearing damage, wear ear plugs or muffs when using sander for hours at a time.

Safety Instructions for Oscillating Edge Belt/ Spindle Sander (continued)

- Do not wear loose clothing, gloves, neckties or jewelry (rings, wrist watches). They can get caught and draw you into moving parts.

Know your sander. Read and understand the owner's manual and labels affixed to the tool. Learn its application and limitations as well as the specific potential hazards.

Plan your work. Think through how you will hold and maneuver the workpiece against the sanding drum or belt.

Use the right tool. Don't force tool or attachment to do a job it was not designed to do.

To reduce the risk of injury from accidental contact with moving parts:

- Do not layout, assemble, or setup work on the sander while any parts are moving.
- **Reduce the risk of accidental starting.** Make sure switch is "OFF" before plugging sander into a power outlet.

Inspect your workpiece. Make sure there are no nails or foreign objects in the part of the workpiece to be sanded.

Plan the way you will hold the workpiece from start to finish. Reduce the risk of awkward operations and hand positions where a sudden slip could cause finger or hand to move into a sanding surface.

Don't overreach. Maintain balance and footing.

Keep face and body to one side. Stay out of line of a possible throwback.

Plan your work to reduce the risk

of THROWBACKS - when the workpiece catches the sanding drum and is torn from your hands:

- Make sure there is no debris between the workpiece and its supports.
- When sanding irregularly shaped workpieces, plan your work support so it will not slip and be pulled from your hands.
- Use extra caution with large, very small or awkward workpieces.
- Never use this tool to finish pieces too small to hold by hand.
- Use extra supports (tables, saw horses, blocks, etc.) for any workpieces large enough to tip when not secured to the work surface.
- **Never** use another person as a substitute for a table extension, or as additional support for a workpiece that is longer or wider than the basic sander table, or to help feed, support or pull the workpiece.
- Sand only one workpiece at a time.
- Clear everything except the workpiece and related support devices off the table before turning the sander on.
- Always feed workpiece from right to left against the direction the sanding sleeve or belt is rotating.
- Do not use drums, sanding sleeves or sanding belts which show visual signs of wear such as grooves, tears or rips.

WARNING: Don't let familiarity (gained from frequent use of your sander) cause a careless mistake. A careless fraction of a second is enough to cause a severe injury.

When Sander is Running

Before starting your work, watch the sander while it runs. If it makes an unfamiliar noise or vibrates excessively, Stop Immediately. Turn the sander off. Unplug the sander. Do not restart until identifying and correcting the problem.

Never leave tool running unattended.

Before using the sander, make sure the sanding belt turns clockwise, when viewed from above.

Keep children away. Keep all visi-

tors a safe distance from the sander and workpiece.

Don't force tool. It will perform better and safer at its designed rate. Press workpiece against the sanding sleeve hard enough to begin sanding without bogging down or binding spindle or belt.

Before freeing any jammed material:

- Turn switch "OFF".
- Unplug the sander.
- Wait for all moving parts to stop.

Before Leaving The Sander

Turn switch off. Don't leave tool until the unit comes to a complete stop.

Make workshop child-proof.

Remove the yellow switch key. Store

it away from children and others not qualified to use the tool. Disconnect master switches. Lock the shop.

Precautions To Take When Sanding Metals

When sanding metals, sparks or hot fragments could cause a fire. To reduce the risk of this:

1. Disconnect any dust collecting hose from the sander.

2. Remove all traces of wood dust from inside the unit before sanding metals.
3. Remove all traces of metal dust from inside the unit before sanding wood again.

Precautions To Take When Sanding Paint

Sanding of lead based paint is not recommended. It is difficult to control the contaminated dust that could cause lead poisoning.

It is also difficult to identify whether or not a paint contains lead. Therefore, we recommend the following precautions when sanding all paints:

1. Protect your lungs. Wear a dust mask or respirator at all times. Wear only dust masks that are suitable for working in lead paint sanding environments. Ordinary painting masks do not offer this protection.

2. Do not allow children or pregnant women to enter the work area until paint sanding job is complete and work area is clean.
3. To prevent ingesting contaminated paint particles: Do not eat, drink, or smoke in a work area where paint is being sanded. After sanding paint, wash and clean up before eating, drinking or smoking. Do not leave food, drinks, or tobacco products in the work area where dust can settle on them.

Precautions To Take When Sanding Paint (continued)

4. Protect the environment when sanding paint. Use a dust collection system if possible. Seal the work area with plastic if necessary. Do not track paint dust outside the work area.
5. Thoroughly clean the work area upon completion of paint sanding

project. If project lasts for an extended period of time, clean work area often. Items such as sanding dust, vacuum filter bags, plastic drop cloths, etc. should be placed in a sealed container and disposed of properly. Clean all items exposed to sanding dust.

Motor Specifications and Electrical Requirements

General Electrical Connections

DANGER: To reduce the risk of electrocution:

1. Use only identical replacement parts when servicing. Servicing should be performed by a qualified service technician.
2. Do not use in rain or where floor is wet.

This tool is intended for indoor use only.

WARNING: Do not touch the terminals of plug when installing or removing the plug to or from the outlet.

If power cord is worn or cut, or damaged in any way, have it replaced immediately.

Power Supply and Motor Specifications

WARNING: To reduce the risk of electrical hazards, fire hazards or damage to the tool, use proper circuit protection. Your tool is wired at the factory for operation using the voltage shown. Connect tool to a power line with the appropriate voltage and a 15-amp branch circuit. To reduce the risk of shock or fire, if power cord is worn or cut, or damaged in any way, have it replaced immediately.

The A-C motor used on this tool is a relay start motor, having the following specifications: It is wired at the factory for operation on 110-120V AC, 60 Hz. operation.

Rated H.P.	3/8
Voltage	110-120
Amperes	5.0
Hertz (Cycles)	60
Phase	Single
RPM	1725
Rotation of Shaft	Clockwise

110-120 Volt, 60 Hz. Tool Information

NOTE: The plug supplied on your tool may not fit into the outlet you are planning to use. Your local electrical code may require slightly different power cord plug connections. If these differences exist refer to and make the proper adjustments per your local code before your tool is plugged in and turned on.

In the event of a malfunction or breakdown, grounding provides a path of least resistance for electric current to reduce the risk of electric shock. This tool is equipped with an electric cord having an equipment grounding conductor and a grounding plug, as shown. The plug must be plugged into a matching outlet that is properly installed and grounded in accordance with all local codes and ordinances.

Do not modify the plug provided. If it will not fit the outlet, have the proper outlet installed by a qualified electrician.

A temporary adapter may be used to connect this plug to a 2-pole outlet, as shown, if a properly grounded outlet is not available. This temporary adapter should be used only until a properly grounded outlet can be installed by a qualified electrician. The green colored rigid ear, lug and the like, extension from the adapter must be connected to a permanent ground such as a properly grounded outlet box.

Improper connection of the equipment grounding conductor could result in a risk of electric shock. The conductor with insulation having an outer surface that is green with or without yellow stripes is the equipment grounding conductor. If repair or replacement of the electric cord or plug is necessary, do not connect the equipment-grounding conductor to a live terminal.

If the grounding instructions are not completely understood, or if you are in doubt as to whether the tool is properly grounded, check with a qualified electrician or service personnel.

WARNING: If not properly grounded, this tool can cause an electrical shock, particularly when used in damp locations, in proximity to plumbing, or out of doors. If an electrical shock occurs there is the potential of a secondary hazard, such as your hands contacting the sanding belt/spindle.

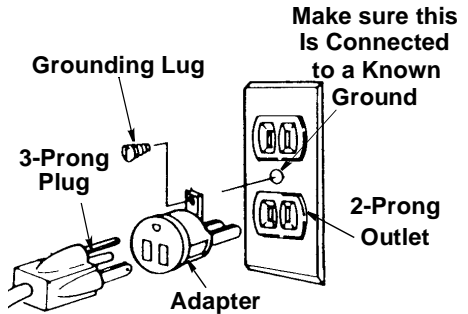
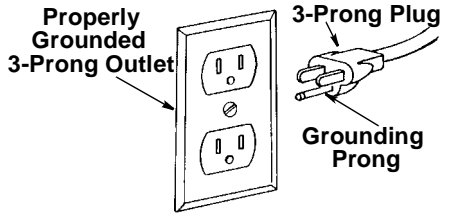

NOTE: The adapter illustrated is for use only if you have a properly grounded 2-prong outlet.

NOTE: In Canada the use of a temporary adapter is not permitted by the Canadian Electrical Code.

Motor Specifications and Electrical Requirements (continued)

Motor Safety Protection

IMPORTANT: To reduce the risk of motor damage, the motor should be blown out or vacuumed frequently to keep sawdust from interfering with normal motor ventilation.

1. Connect this tool to a power source with the appropriate voltage for your model and a 15-amp branch circuit with a 15-amp fuse or circuit breaker. Using the wrong size fuse can damage the motor.
2. If the motor won't start, turn off the power switch immediately and unplug the tool. Check the spindle to make sure it turns freely. If the spindle is free, try to start the motor again. If the motor still does not start, refer to the "Trouble-shooting" chart.
3. If the motor suddenly stalls while sanding, turn off the power switch, unplug the tool, and remove the workpiece from the belt/drum. The motor may now be restarted and the sanding finished.
4. Fuses may "blow" or circuit breakers may trip frequently if:
 - a. **Motor Is Overloaded**-Overloading can occur if you sand too rapidly or make too many start/stops in a short time.
 - b. Line voltages should not be more

than 10% above or below the name-plate voltage. For heavy loads, however, the voltage at motor terminals must equal the voltage specified for your model.

5. Most motor troubles may be traced to loose or incorrect connections, overload, low voltage (such as small size wire in the supply circuit) or to overly long supply circuit wire. Always check the connections, the load and supply circuit whenever motor doesn't work well. Check wire sizes and extension cord length with the Wire Size Chart.

Wire Sizes

NOTE: Make sure the proper extension cord is used and is in good condition.

The use of any extension cord will cause loss of power. To keep this to a minimum and to prevent overheating and motor burn-out, use the table shown to determine the minimum wire size (A.W.G.) extension cord.

Use only 3-wire extension cords with 3-prong grounding type plugs and 3-pole receptacles.

Extension Cord Length	Gauge (A.W.G.)
0-25 Ft.	16
26-50 Ft.	14

Unpacking and Checking Contents

1. Remove tool from carton by lifting unit.
2. Place the tool on a secure, stationary work surface and look the tool over carefully.

WARNING: For your own safety, never connect plug to power source outlet, or insert switch key until all assembly steps are complete and until you have read and understood the entire owners manual.

WARNING: To reduce the risk of injury, if any parts are missing, do not attempt to assemble the sander, plug in the power cord, or turn the switch on until the missing parts are obtained and installed correctly.

List of Loose Parts

NOTE: Before beginning assembly, check that all parts are included. If you are missing any part, do not assemble the sander. Call 1-866-539-1710 or E-mail us at info@ridgidwoodworking.com if any parts are damaged or missing. Sometimes small parts can get lost in packaging material. Do not throw away any packaging until sander is put together. Check packaging for missing parts before contacting RIDGID.

Item	Description	Qty.
A	Oscillating Edge Belt/ Spindle Sander.....	1
B	Spacer Ring Inserts	
	1/2" I.D.	1
	1" I.D.	1
	1-1/2" I.D.	1
	2" I.D.	1
C	Drums	
	3/4" x 4-1/2".....	1
	1" x 4-1/2".....	1
	1-1/2" x 4-1/2"	1
	2" x 4-1/2".....	1
D	Sandpaper Sleeves	
	1/2" x 4-1/2".....	1
	3/4" x 4-1/2".....	1
	1" x 4-1/2".....	1
	1-1/2" x 4-1/2"	1
	2" x 4-1/2".....	1
E	Sanding Belt (Installed)	
	4" x 24".....	1
F	Insert	1
G	Operators Manual	1
H	Bag of Loose Parts	
	Containing the following parts:	
	Rubber feet	4
	Washer, Flat 21/64 x 1-3/4 x 1/8	1
	Washer, Flat 21/64 x 7/8 x 3/64	1
	Washer, Flat 21/64 x 5/8 x 1/32	1
	Switch Key	1
	Hex "L" Wrench 3/32	1
	Hex "L" Wrench 5/32	1

Loose Parts

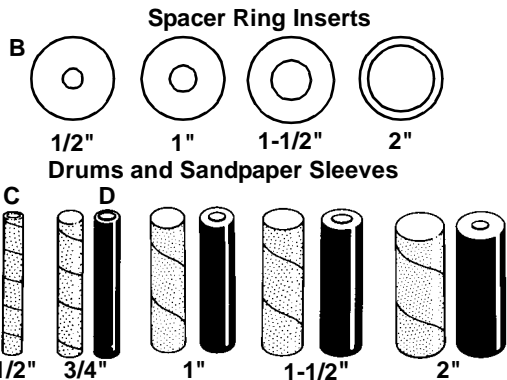
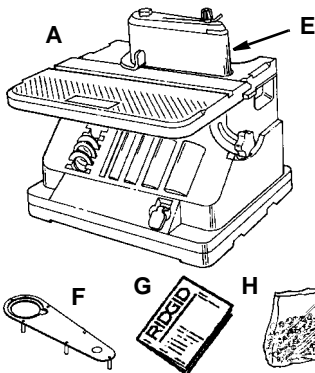

NOTE: The sander is shipped with the 4" x 24" sanding belt attached.

NOTE: Parts shown are not actual size.

Assembly

NOTE: The sander is preassembled except for the attachment of the rubber feet.

Mounting Rubber Feet To Base

Place the sander directly on the table surface.

1. From the parts bag locate the four rubber feet.
2. Place the sander on its side so the bottom of the base is facing toward the front.
3. Locate the four holes in each corner of the base and place one of the rubber feet in each of these holes.
4. Position sander in the upright position and apply pressure in the downward position to ensure the feet are inserted securely.

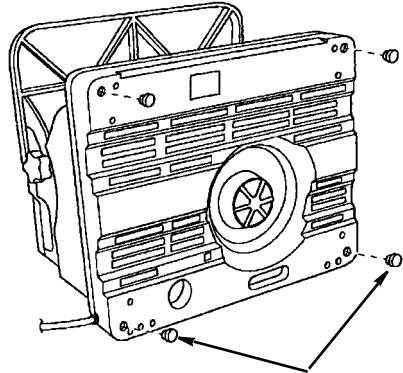

Rubber Feet

CAUTION: To reduce the risk of injury from tool movement, the supporting surface where sander is mounted should be examined carefully after mounting to insure no movement during use can result. If any tipping or walking is noticed, secure to workbench or supporting surface before operating sander.

Parts Storage

On board storage has been provided for all washers, spacers, drums, sleeves and hex "L" wrenches. All front loaded parts can be protected from incidental dislodging by lowering the table all the way down until it rests against the base and tightening the knob.

Storage for the sanding belt assembly and table insert is provided in the pocket on the rear of the base.

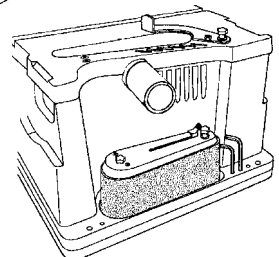
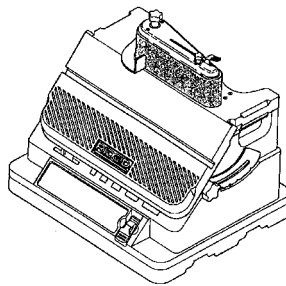

Removing the Sanding Belt Assembly

WARNING: To reduce the risk of injury from accidental start, make sure tool is unplugged before removing the sanding belt assembly.

1. Loosen the backstop knob and pivot the backstop out of the way. Tighten the backstop knob.
2. Remove the spindle knob and lift off the sanding belt assembly. **NOTE:** Knob turns clockwise to loosen.
3. Store assembly in pocket in rear of base.

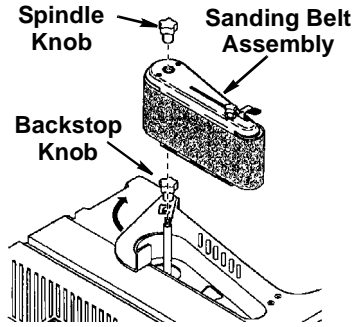

Installing the Sanding Belt Assembly

1. Remove the fan and clean sawdust from inside table recess.
2. Slide the fan onto the motor shaft (vanes face down) aligning slot with roll pin as shown. The fan is used in all sanding operations.
3. Slide bed assembly down motor shaft. Align drive drum splines with the slots in the fan. Place bed assembly into the wear plate opening as shown.
4. Tighten spindle knob. Do not over-tighten. **NOTE:** Knob turns counter-clockwise to tighten.
5. Install sanding belt (see "Removing/Installing the Sanding Belt", page 19).
6. Plug the power cord into the power source and install the key.

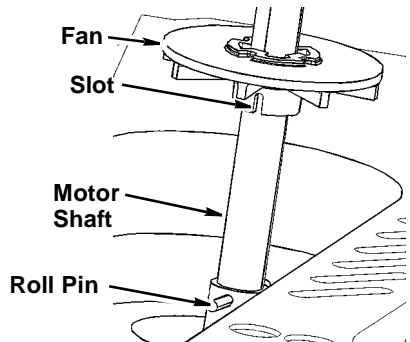
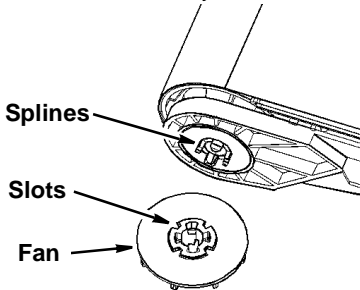
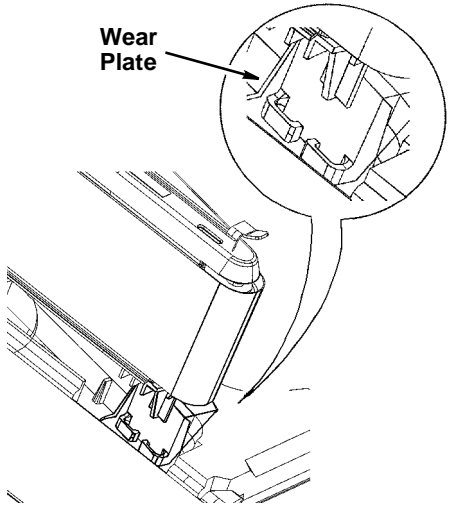

Assembly (continued)

Installing Sanding Sleeves Larger than 1/2" Diameter

WARNING: To reduce the risk of injury from accidental starting, always turn switch "OFF" and remove switch key before removing or replacing the spacer ring inserts, sleeves and drums.

1. Remove the fan and clean sawdust from inside table recess.
2. Slide the fan onto the motor shaft (vanes face down) aligning slot with roll pin. The fan is used with all drums and sleeves.
3. Install the table insert.
4. Use a straight edge as shown to make sure the table insert is flush with the table.

If necessary adjust the set screws in the table insert with the 3/32 hex "L" wrench provided.

5. Slide the sanding sleeve-rubber drum onto the spindle. **NOTE:** If the drum is difficult to slide over the spindle, apply talcum powder to the spindle.
6. Position spacer ring insert in the table recess. (See recommended spacer ring insert selection area from table on page 15). Use the smallest spacer ring insert that will fit over the drum.
7. Place desired sanding sleeve on correct drum. **NOTE:** If the sanding sleeve is difficult to slide over the drum, apply talcum powder to the outside surface of the rubber drum.
8. Install the correct upper spindle washer and tighten the knob. **Do not over-tighten.** **NOTE:** Knob turns counter-clockwise to tighten.
9. Plug power cord in the power source and install the yellow switch key.

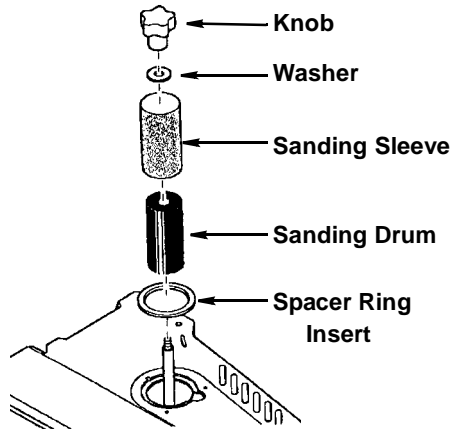
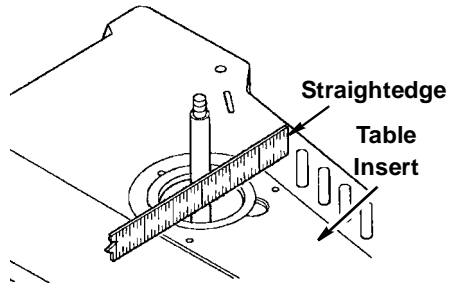

Installing Sanding Sleeves for the 1/2" Diameter Sanding Drum

WARNING: To reduce the risk of injury from accidental starting, always turn switch "OFF", unplug the sander and remove switch key before removing or replacing the spacer ring inserts, sleeves and drums.

1. Remove the fan and clean sawdust from inside table recess.
2. Slide the fan onto the motor shaft (vanes face down) aligning slot with roll pin. The fan is used with all sanding operations.
3. Install the table insert.
4. Use a straight edge as shown to make sure the table insert is flush with the table
If necessary adjust the set screws in the table insert with the 3/32 hex "L" wrench provided.
5. Position 15/16" inside diameter spacer

- ring insert in the table recess.
6. Locate 1/2" sanding sleeve and slide it on the spindle. **(Rubber drum is not used.)**
7. Install the upper spindle washer and tighten the knob. **Do not overtighten.** **NOTE:** Knob turns counterclockwise to tighten.
8. Plug the power cord in the power source and install the yellow switch key.

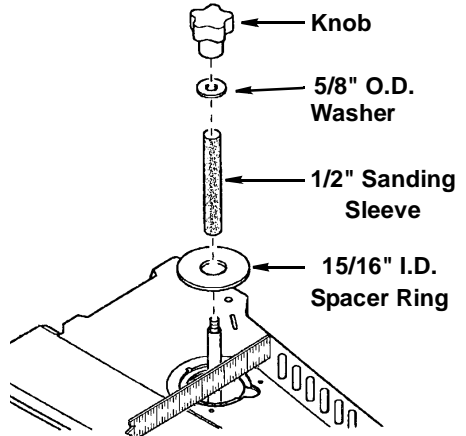

Selection Of Spacer Ring Inserts And Upper Spindle Washers

WARNING: Using the wrong spacer ring insert may permit small pieces of wood or finger tips to become wedged between the abrasive surface and the insert.

Sanding Sleeve Diameter	Spacer Ring Insert Opening Inside Diameter	Upper Spindle Washer Outside Diameter
1/2 Inch	15/16 Inch	5/8"
3/4 Inch		
1 Inch	1-3/16 Inch	7/8"
1-1/2 Inch	1-11/16 Inch	
2 Inch	2-3/16 Inch	1-3/4"

- Use the smallest spacer ring insert that will fit over the drum.
- Use the largest upper spindle washer that will not protrude past sanding sleeve.

Assembly (continued)

Bolting Oscillating Edge Belt/Spindle Sander To Workbench

If sander is to be used in a permanent location, it should be fastened securely to a firm supporting surface such as a workbench, with either bolts or drywall screws.

Fastening with bolts

1. Use 1/4" bolts, washers, and nuts (not included). The bolt length should be 1-1/2" plus the thickness of the workbench.
2. Locate and mark the holes where the sander is to be mounted.
3. Drill (4) 3/8" diameter holes through workbench.
4. Place sander on workbench, aligning holes in base with holes drilled in workbench.
5. Insert (4) 1/4" diameter bolts and washers and attach nuts securely.

Fastening with screws

Drive (4) 2-1/2" long screws through the holes in the base and through the workbench. Do not overtighten the screws.

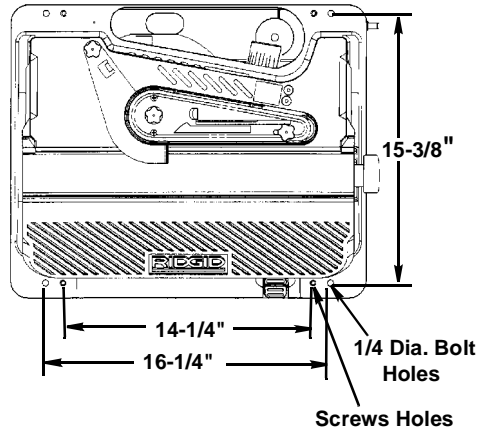

CAUTION: To reduce the risk of injury from tool movement, use either 1/4" diameter screws and nuts or 2-1/2" long screws.

Clamping Oscillating Edge Belt/Spindle Sander To Workbench

An alternative method of mounting is to fasten the sander to a mounting board. The board should be sufficient size to avoid tipping while in use. Any good grade of plywood or chipboard with a 3/4" thickness is recommended. (Thinner chipboard can break.)

NOTE: For proper stability, holes must be countersunk so screw heads are flush with the surface of supporting board.

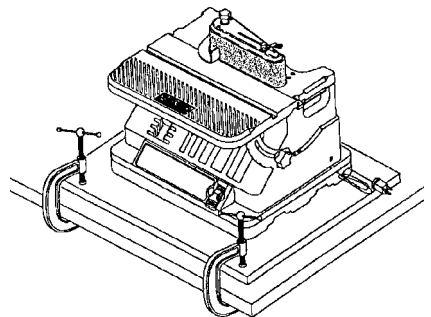

Supporting Oscillating Edge Belt/ Spindle Sander to Sawhorses

The sander has provisions for being supported by sawhorses. The sawhorse can be built with the crosspiece either vertical or horizontal. Make sure the sawhorses are secure.

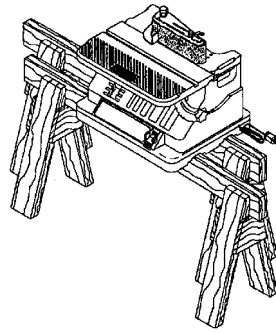

Alignment

Squaring Front Table

WARNING: To reduce the risk of injury from accidental start, make sure tool is unplugged before aligning.

Tools Needed

1. Use a combination square to check the angle of the front table with the sanding belt. (**NOTE:** Combination square is not supplied.)
2. If the front table is not 90° to the sanding belt:
 - a. Use the hex wrench provided and "back out" both #10 set screws located on each side of the table.
 - b. Loosen the front table lock knob and adjust the front table 90° to the sanding belt.
 - c. Tighten the front table lock knob.
 - d. Adjust both set screws to contact the front table.
3. Adjust detent if necessary
 - a. Loosen the two pan head screws that secure the detent.
 - b. Adjust detent so that it engages the notches in the bracket table lock.
 - c. Tighten the two pan head screws.



Combination Square

Combination Square Must be True

Draw Light Line on Board Along This Edge

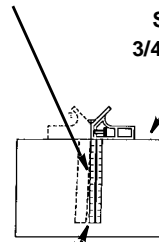

Straight Edge of Board 3/4" Thick, This Edge Must Be Perfectly Straight

Should be no Gap or Overlap when Square is Flipped Over in Dotted Position

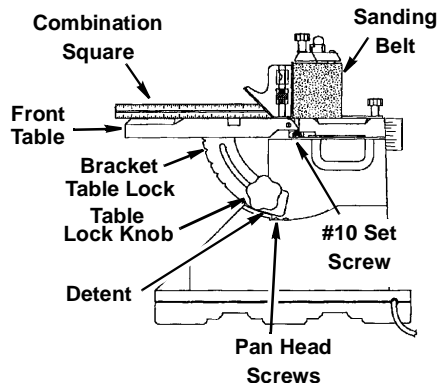

Alignment (continued)

Aligning Belt To Miter Gauge Slot

The sanding belt is installed at the factory; however, check and make sure the belt is parallel to the miter gauge groove:

1. Use a combination square to check the distance from the miter gauge groove to the belt assembly as shown.
2. If adjustment is required, use a 5/32 inch hex "L" wrench provided with unit to loosen the two flat head socket recess screws on the table.
3. Adjust the bed assembly as needed to make it parallel or same distance to the miter gauge slot.
4. Tighten two screws.

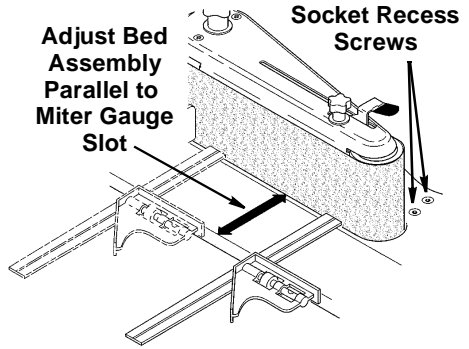

Removing/Installing the Sanding Belt

Tensioning and Tracking

WARNING: To reduce the risk of injury from accidental start, make sure tool is unplugged before removing or installing sanding belt.

Some sanding belts have a “directional arrow” on the inside or smooth side. If there is an arrow, the belt must run in the direction of the arrow so the splice will not come apart. If there is no arrow the belt may be put on either direction.

1. Slide the tension lever to the left to release the belt tension.
2. Remove the sanding belt.
3. Place the replacement sanding belt over the drums as shown. Make sure the belt is centered on both drums.
4. Slide the tension lever to the right to apply belt tension.
5. Plug in the power cord. Insert the yellow switch key and turn the unit “ON” and immediately “OFF”, noting if the belt tends to slide off the drums. If it did not tend to slide off, it is tracking properly.
6. If the sanding belt runs down towards the table, turn the tracking knob clockwise 1/4 turn.
7. If the sanding belt, runs up away from the table, turn the tracking knob counterclockwise 1/4 turn.
8. Turn switch “ON” and immediately “OFF” again, noting belt movement. Readjust tracking knob if necessary.

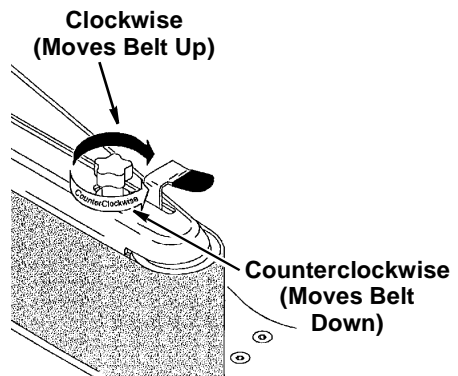
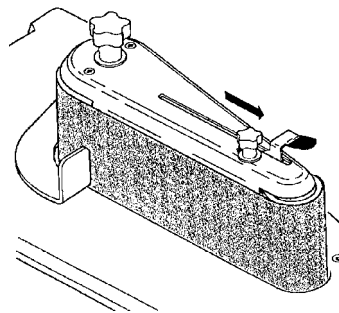
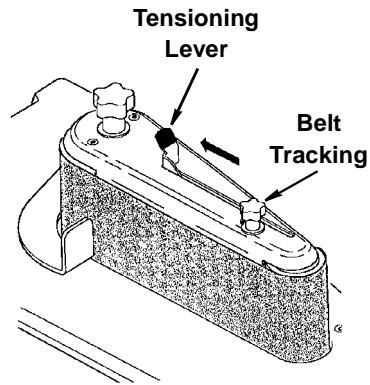

Getting to Know Your Spindle Sander

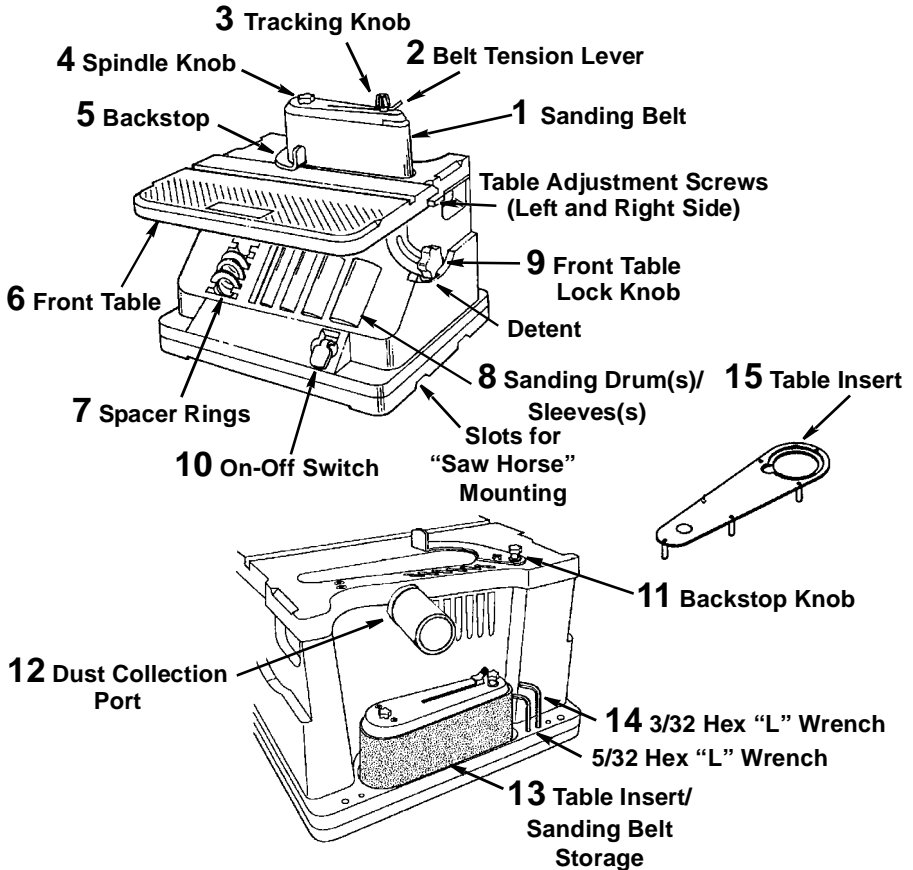

WARNING: To reduce the risk of injury from accidental start, turn switch "OFF" and remove plug from power source outlet before making any adjustments.

1. **Sanding Belt.** Removes material from wood. Oscillates (3/4") up and down to sand faster and prevents burning of the workpiece.
2. **Belt Tension Lever.** Slide lever left to release the sanding belt tension; slide right to apply belt tension.
3. **Tracking Knob.** Turning knob counterclockwise causes sanding belt to move towards the table; turning knob clockwise causes sanding belt to move away from the table.
4. **Spindle Knob.** Loosen knob to remove sanding belt assembly (or sanding drum) and change to spindle sanding (or belt sanding). NOTE: Knob has left hand threads. Turn knob clockwise to loosen and counterclockwise to tighten.
5. **Backstop.** Supports the workpiece on the sanding belt.
6. **Front Table.** Supports the workpiece. Can also be tilted for bevel sanding.
7. **Spacer Ring.** Fits around drum to help support workpiece.
8. **Sanding Sleeve/Drum.** Removes material from wood. Oscillates up and down to sand faster and prevents burning the workpiece.
9. **Table Lock Knob.** Loosening knob allows the front table to be tilted for bevel sanding.

10. On-Off Switch

- 11. **Backstop Knob.** Loosening knob allows backstop to be pivoted.
- 12. **Dust Collection Port.** 2-1/2" opening for wet/dry vac hook-up.
- 13. **Table Insert/Sanding Belt Storage.** Holds table insert or sanding belt when not being used.
- 14. **Hex "L" Wrench.** Use 3/32" wrench to adjust front table and table insert. Use 5/32" wrench to adjust belt to miter gauge slot.
- 15. **Table Insert.** Helps to support work-piece when drum sanding.

On-Off Switch

The On-Off switch has a locking feature. **This Feature Is Intended To Help Prevent Unauthorized And Possible Hazardous Use By Children And Others.**

1. To turn sander "ON" insert key into switch.
- NOTE:** Key is made of yellow plastic, located in loose parts bag.
2. Insert finger under switch lever and **Pull** end of switch out.
3. To turn sander "OFF". **Push** lever in.

WARNING: Never leave the sander unattended until it has come to a complete stop.

4. To lock switch in "OFF" position, hold switch "IN" with one hand. **Remove** key with other hand.

WARNING: For your own safety, always lock the switch "OFF" when sander is not in use. Remove key and keep it in a safe place. Also, in the event of a power failure (all of your lights go out) turn switch off, remove the key and store it remote from sander.

CAUTION: Before turning switch on, make sure the belt or drum and sleeve are properly installed.

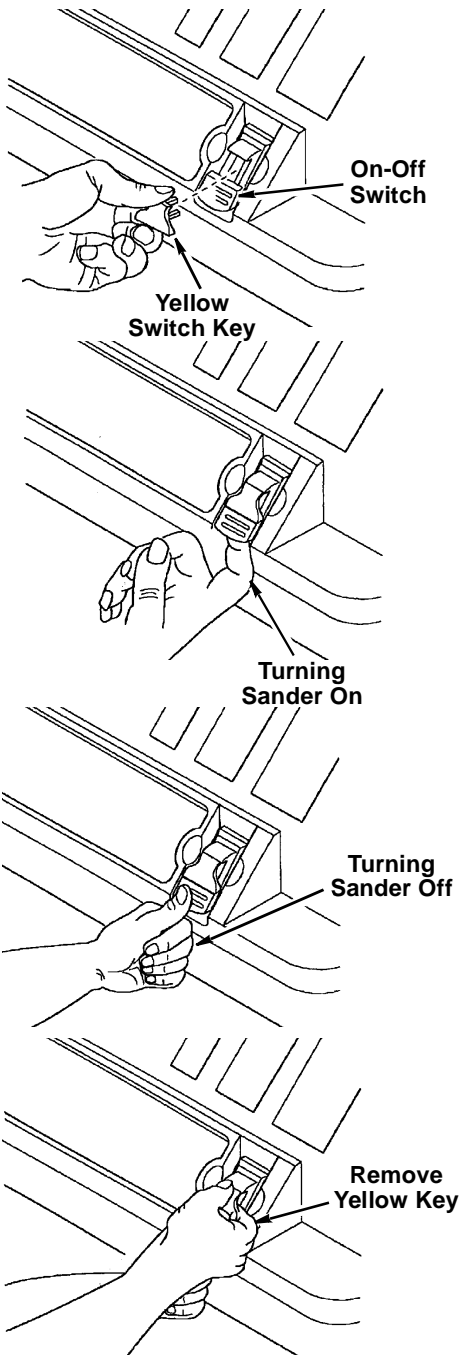

Safety Instructions for Oscillating Edge Belt/Spindle Sander

Before Using The Sander

WARNING: To reduce the risk of mistakes that could cause serious, permanent injury, do not plug the sander in until the following steps are completed.

- Assembly. (See pages 12-19)

- Learn the use and function of the ON-OFF switch. (See page 21)
- Review and understanding of all safety instructions and operating procedures in this manual.
- Review of the maintenance methods for this sander. (See page 29)

When Installing Or Moving The Sander

Avoid dangerous environment.

Use the sander in a dry, indoor place protected from rain. Keep work area well lighted.

To reduce the risk of burns or other fire damage, never use the sander near flammable liquids, vapors or gasses.

To reduce the risk of injury or death from electrical shock:

- Ground the sander. This sander has an approved 3-conductor cord and a 3-prong grounding type plug. Use only 3-wire, grounded outlets rated 120 volts, 15 amperes (amps). The green conductor in the cord is the grounding wire. To reduce the risk of electrocution, **Never** connect the green wire to a live terminal.
- Make sure your fingers do not touch the plug's metal prongs when plugging or unplugging the sander.
- Never use this or any power sander

for wet sanding. Doing so could cause electrocution, serious injury or worse.

To reduce the risk of injury from unexpected sander movement:

- Always unplug the sander before moving it.
- Put the sander on a firm level surface where there is plenty of room for handling and properly supporting the workpiece.
- Attach rubber feet.
- Support the sander so it does not rock.
- Bolt the sander to its work surface. Use the fasteners and method shown in "Assembly." (page 16)
- **Never stand on tool.** Serious injury could occur if the tool tips. Do not store anything above or near the tool where anyone might stand on the tool to reach them.

Before Each Use

Inspect your sander. Check for:

- alignment of moving parts,
- binding of moving parts,
- broken or damaged parts,
- work parts that cause a gap larger than 1/16" between work support and sanding surface,
- sanding belt narrower than 4 inches. Narrower belts uncover parts that

- could trap your fingers,
- worn or damaged electric cords,
- stable mounting, and
- any other conditions that may affect the way the sander works.
- Remove adjusting keys and wrenches. Form a habit of checking for and removing keys and adjusting wrenches from table top before turning sander on.

If any part is missing, bent, or broken in any way, or any electrical parts don't work properly, turn the sander off and unplug the sander. **Replace** damaged, missing, or failed parts before using the sander again.

Disconnect the sander to reduce the risk of injury from accidental starting. Turn switch off, unplug sander and remove the switch key before changing the setup or sanding drum.

Maintain tools with care. Keep the sander clean for maximum and safest performance.

To reduce the risk of injury from jams, slips or thrown pieces:

- **Use only recommended accessories.**
- **Use the correct spacer ring insert.** The opening between the sanding sleeve and insert must be 5/32 of an inch or less. (See page 15)
- **All sanding drums, washers and knobs are tight.** No parts should have excessive play prior to operating unit.
- **Keep work area clean.** Cluttered work surfaces invite accidents. Floor must be clean and dry for stable footing.

Plan Ahead To Protect Your Eyes, Hands, Face and Ears

Dress for Safety

- Any power sander can throw foreign objects into the eyes. This can result in permanent eye damage. Always wear safety goggles, not glasses complying with ANSI Z87.1 (or in Canada CSA Z94.3-99) shown on package. Everyday eyeglasses have only impact resistant lenses. They are not safety glasses. Safety goggles are available at many local retail stores. Glasses or goggles not in compliance with ANSI or CSA could seriously hurt you when they break.
- For dusty operations, wear a dust mask along with safety goggles.
- Wear nonslip footwear.
- Tie back long hair.
- Roll long sleeves above the elbow.
- Noise levels vary widely. To reduce the risk of possible hearing damage, wear ear plugs or muffs when using sander for hours at a time.
- Sanding operations are usually dusty. Wear a dust mask along with the safety goggles.

- Do not wear loose clothing, gloves, neckties or jewelry (rings, wrist watches). They can get caught and draw you into moving parts.

Know your sander. Read and understand the owner's manual and labels affixed to the tool. Learn its application and limitations as well as the specific potential hazards.

Plan your work. Think through how you will hold and maneuver the work-piece against the sanding drum or belt.

Use the right tool. Don't force tool or attachment to do a job it was not designed to do.

To reduce the risk of injury from accidental contact with moving parts:

- Do not layout, assemble, or setup work on the sander while any parts are moving.
- **Reduce the risk of accidental starting.** Make sure switch is "OFF" before plugging sander into a power outlet.

Safety Instructions for Oscillating Edge Belt/ Spindle Sander (continued)

Inspect your workpiece make sure there are no nails or foreign objects in the part of the workpiece to be sanded.

Plan the way you will hold the workpiece from start to finish.

Reduce the risk of awkward operations and hand positions where a sudden slip could cause finger or hand to move into a sanding surface.

Don't overreach. Maintain balance and footing.

Keep face and body to one side.

Stay out of line with a possible throw-back.

Plan your work to reduce the risk of **THROWBACKS** - when the workpiece catches the sanding drum and is torn from your hands:

- Make sure there's no debris between the workpiece and its supports.
- When sanding irregularly shaped workpieces, plan your work support so it will not slip and be pulled from your hands.
- Use extra caution with large, very small or awkward workpieces.
- Never use this tool to finish pieces

too small to hold by hand.

- Use extra supports (tables, saw horses, blocks, etc.) for any workpieces large enough to tip when not secured to the work surface.
- **Never** use another person as a substitute for a table extension, or as additional support for a workpiece that is longer or wider than the basic sander table, or to help feed, support or pull the workpiece.
- Sand only one workpiece at a time.
- Clear everything except the workpiece and related support devices off the table before turning the sander on.
- Always feed workpiece from left to right against the direction the drum sleeve is rotating.
- Do not use drums, sanding sleeves or belts which show visual signs of wear such as grooves, tears or rips.

WARNING: Don't let familiarity (gained from frequent use of your sander) cause a careless mistake. A careless fraction of a second is enough to cause a severe injury.

When Sander is Running

Before starting your work, watch the sander while it runs. If it makes an unfamiliar noise or vibrates excessively, Stop Immediately. Turn the sander off. Unplug the sander. Do not restart until identifying and correcting the problem.

Never leave tool running unattended.

Before using the sander, make sure the sanding belt turns clockwise,

when viewed from above.

Keep children away. Keep all visitors a safe distance from the sander and workpiece.

Don't force tool. It will perform better and safer at its designed rate. Press workpiece against the sanding sleeve or belt hard enough to begin sanding without bogging down or binding spindle.

Before freeing any jammed material:

- Turn switch "OFF".
- Unplug the sander.
- Wait for all moving parts to stop.

Before Leaving The Sander

Turn switch off. Don't leave tool until the unit comes to a complete stop.

Make workshop child-proof.

Remove the yellow switch key. Store it away from children and others not qualified to use the tool. Disconnect master switches. Lock the shop.

Precautions To Take When Sanding Metals ---

When sanding metals, sparks or hot fragments could cause a fire. To reduce the risk of this:

1. Disconnect any dust collecting hose from the sander.

2. Remove all traces of wood dust from inside the unit before sanding metals.
3. Remove all traces of metal dust from inside the unit before sanding wood again.

Precautions To Take When Sanding Paint ---

Sanding of lead based paint is not recommended. It is difficult to control the contaminated dust that could cause lead poisoning.

It is also difficult to identify whether or not a paint contains lead. Therefore, we recommend the following precautions when sanding **all** paints:

1. Protect your lungs. Wear a dust mask or respirator at all times. Wear only dust masks that are suitable for working in lead paint sanding environments. Ordinary painting masks do not offer this protection.
2. Do not allow children or pregnant women to enter the work area until paint sanding job is complete and work area is clean.
3. To prevent ingesting contaminated paint particles: Do not eat, drink, or

smoke in a work area where paint is being sanded. After sanding paint, wash and clean up before eating, drinking or smoking. Do not leave food, drinks, or tobacco products in the work area where dust can settle on them.

4. Protect the environment when sanding paint. Use a dust collection system if possible. Seal the work area with plastic if necessary. Do not track paint dust outside the work area.
5. Thoroughly clean the work area upon completion of paint sanding project. If project lasts for an extended period of time, clean work area often. Items such as sanding dust, vacuum filter bags, plastic drop cloths, etc. should be placed in a sealed container and disposed of properly. Clean all items exposed to sanding dust.

Basic Sanding Operation

Sandpaper Selection

Selecting the correct size diameter, correct size grit, and correct type sandpaper is an extremely important step in achieving a high quality sanded finish. Aluminum oxide, silicon carbide, and other synthetic abrasives are best for power sanding. Natural abrasives, such as flint and garnet, are too soft for economical use in power sanding.

In general, coarse grit will remove the most material and finer grit will produce the best finish in all sanding operations. The condition of the surface to be sanded will determine which grit will do the job. If the surface is rough, start with a coarse grit and sand until the surface is uniform. Medium grit may then be used to remove scratches left by the coarser grit and finer grit used for finishing of the surface. Always continue sanding with each grit until surface is uniform.

NOTE: Do Not use sander without sandpaper. Doing so will damage the rubber drum.

Select and install the desired sanding sleeve for your particular application. Sanding sleeves from 1/2" to 2" can be used with this sander. Choose one that is close in size to the workpiece you are sanding. Also install the appropriate spacer ring insert (page 15).

WARNING: Failure to use the correct size spacer ring insert with its matching sanding sleeve could result in fingers being pinched or the workpiece being pulled down between the spacer ring insert and sanding sleeve.

NOTE: The correct size sanding belt is 4" x 24". These belts are available in coarse, medium and fine grits.

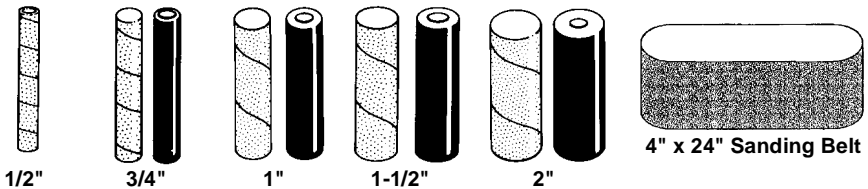

Surface Sanding on the Sanding Belt

WARNING: To reduce the risk of injury from slips, jams or thrown pieces, adjust the backstop to clear the sanding surface by no more than 1/16 of an inch. When checking clearance between the sanding belt and backstop, press the sanding belt flat against the metal bed beneath it.

Hold the workpiece firmly with both hands, keeping fingers away from the sanding belt. Keep the end butted against the backstop and move the work evenly across the sanding belt. Use caution when sanding very thin pieces. For sanding long pieces the backstop can be rotated out of the way. Apply only enough pressure to allow the sanding belt to remove material.

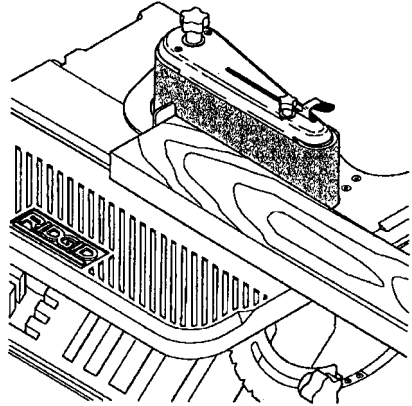

End Sanding on the Sanding Belt

Move the work evenly across the sanding belt. For accuracy, use a miter gauge accessory (not included).

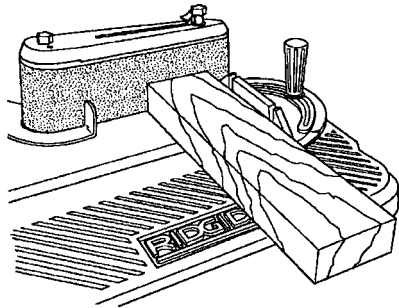

Sanding Curved Edges

Inside curves are best sanded with the sander assembled in the spindle mode. However, inside curves larger than 1-1/2" may be sanded on the drive drum when in the belt sander mode.

Although it is possible to lightly sand on the idler drum end of the belt sanding assembly, it is not recommended. The idler drum is an integral part of the belt tracking mechanism. It is spring loaded to maintain proper tension. Use of the idler drum to sand curves may cause belt to track improperly.

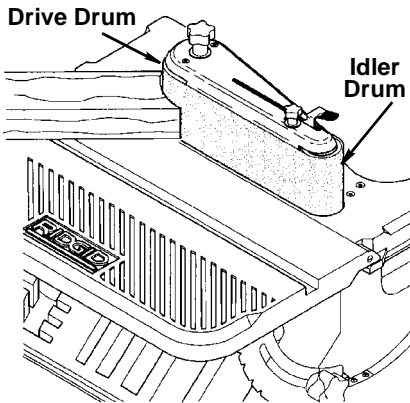

Basic Sanding Operation (continued)

Feed Direction

WARNING: To prevent thrown workpiece, feed workpiece against sanding sleeve from left to right as shown.

The sanding sleeve rotates clockwise. Feed the workpiece against the sanding sleeve from left to right as shown. When fed from left to right, the rotation of the sanding sleeve sands against the workpiece. If fed in the opposite direction, the rotation forces of the spinning sanding sleeve will tend to throw or bounce the workpiece away from the sanding sleeve. This could cause loss of control of workpiece or injury.

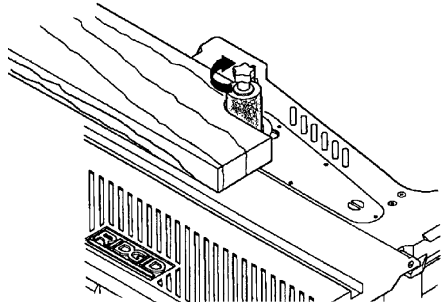

Dust Collection Capability

A standard 2-1/2" dust exhaust port has been provided to make dustless sanding possible. It is on the rear of your sander as shown. The pickup adapter end of a vacuum hose fits inside the dust exhaust port with a wedge fit.

Even with a dust collection system, it is necessary to periodically clean sanding dust from the recess in the table. Sawdust buildup in the table recess may prevent the belt or spindle from making a complete oscillation, which may cause premature wear.

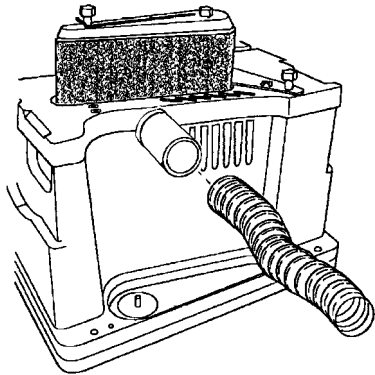

Transporting Sander

When using your sander in a portable application, it is acceptable to lift and carry sander by the table top by the carry handles. Be careful when transporting to reduce the risk of dislodging accessories, spacer ring inserts, wrench, and upper spindle washers from their respective storage areas.

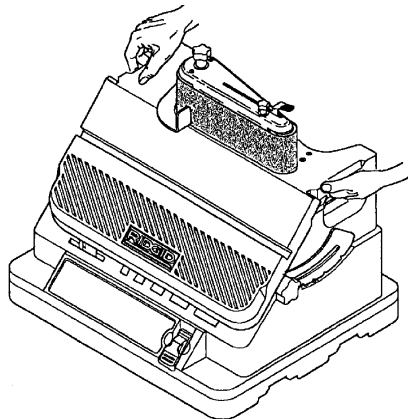

Maintenance

WARNING: For your own safety, turn switch "OFF" and remove plug from power source outlet before adjusting or maintaining your sander.

WARNING: To reduce the risk of electrocution or fire, any repairs to electrical systems should be done only by qualified service technicians. Unit must be reassembled exactly to factory specifications.

If power cord is worn or cut, or damaged in anyway, have it replaced immediately. Frequently blow out or vacuum out any dust that may accumulate inside the motor.

Lubrication

All bearings in tool are self-lubricating. They require no further lubrication.

RIDGID Recommends the Following Accessories

WARNING: Use only accessories recommended for this sander. Using other accessories may be dangerous.

Item	SKU No.
Miter Gauge.....	AC1021
Switch Key.....	AC1000
Universal Legset.....	AC9910
Replacement Sanding Sleeves, 2 pk.....	See Chart Below

Size	Grit	SKU No.	Size	Grit	SKU No.
1/2"	Fine	AC7001	1-1/2"	Fine	AC7010
	Medium	AC7002		Medium	AC7011
	Coarse	AC7003		Coarse	AC7012
3/4"	Fine	AC7004	2"	Fine	AC7013
	Medium	AC7005		Medium	AC7014
	Coarse	AC7006		Coarse	AC7015
1"	Fine	AC7007			
	Medium	AC7008			
	Coarse	AC7009			

Do not use any accessory unless you have received and read complete instructions for its use.

NOTE: 4" x 24" Replacement sanding belts are available at your local Home Depot Store.

Wiring Diagram

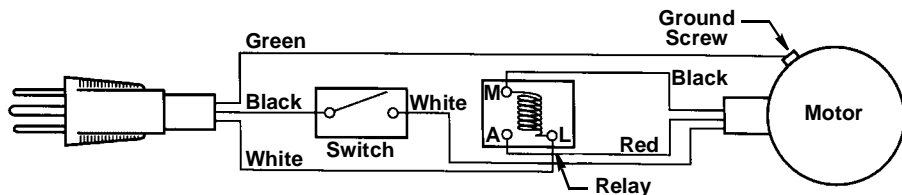

Troubleshooting

WARNING: For your own safety, turn switch "OFF", and remove plug from power source outlet before troubleshooting your sander.

TROUBLE	PROBABLE CAUSE	REMEDY
Excessive noise NOTE: The sander will make some noise when it is operating normally	1. Motor gearbox not operating correctly.	1. Consult Authorized Service Center, any attempt to repair this motor or gearbox may create a hazard unless repair is done by a qualified service technician.
Motor fails to develop full power, starts slowly, or fails to come up to full speed. NOTE: Low voltage	1. Circuit overloaded with lights, appliances and other motor. 2. General overloading of power company facilities. 3. Motor relay not operating.	1. Do not use sander on heavily loaded circuits 2. Request a voltage check by qualified electrician 3. Have relay replaced. Consult Authorized Service Center. Any attempt to repair this relay may create a hazard unless repair is done by a qualified service technician.
Motor overheats	1. Motor overloaded.	1. Reduce pressure on work-piece.
Motor stalls (resulting in blown fuses or circuit breakers)	1. Motor relay not operating. 2. Voltage too low. Circuit overloaded or general overloading of power company facilities. 3. Incorrect fuses or circuit breakers in power line.	1. Have relay replaced. Consult Authorized Service Center. Any attempt to repair this relay may create a hazard unless repair is done by a qualified service technician. 2. Request voltage check by qualified electrician 3. Install correct fuse or circuit breaker.

TROUBLE	PROBABLE CAUSE	REMEDY
Frequent opening of fuse or circuits breaker	<ol style="list-style-type: none"> 1. Motor overloaded. 2. Incorrect fuses or circuit breaker in power line. 3. Relay not operating. 	<ol style="list-style-type: none"> 1. Feed work slower 2. Install correct fuse or circuit breakers. 3. Have relay replaced. Consult Authorized Service Center. Any attempt to repair this relay may create a hazard unless repair is done by a qualified service technician.
Motor will not run	<ol style="list-style-type: none"> 1. Damaged On-Off Switch/Cord. 2. Burned out motor, no power to motor or low voltage. 	<ol style="list-style-type: none"> 1. Replace damaged parts before using sander. 2. Consult Authorized Service Center. Any attempt to repair this motor may create a hazard unless repair is done by a qualified service technician.
Sanding drum or belt slips or slows down easily	<ol style="list-style-type: none"> 1. Applying too much pressure to workpiece. 2. Spindle knob too loose. 	<ol style="list-style-type: none"> 1. Reduce pressure on workpiece. 2. Tighten spindle knob.
Wood burns while sanding	<ol style="list-style-type: none"> 1. Sanding drum is glazed with sap. 	<ol style="list-style-type: none"> 1. Replace sandpaper.
Sandpaper doesn't remove material	<ol style="list-style-type: none"> 1. Sandpaper is compacted with sawdust. 	<ol style="list-style-type: none"> 1. Replace sandpaper.
Spindle doesn't go through full 3/4" travel	<ol style="list-style-type: none"> 1. Sawdust is compacted under lower drum washer. 2. Fan not installed. 3. Damaged gearbox. 	<ol style="list-style-type: none"> 1. Vacuum sawdust from area of lower drum washer. 2. Ensure that fan is installed with vanes face down. 3. Consult Authorized Service Center. Any attempt to repair this gearbox may create a hazard unless repair is done by a qualified service technician.

Repair Parts

Parts List For RIDGID Oscillating Edge Belt/Spindle Sander Model EB44241

RIDGID parts are available on-line at www.ridgidparts.com

Figure 1

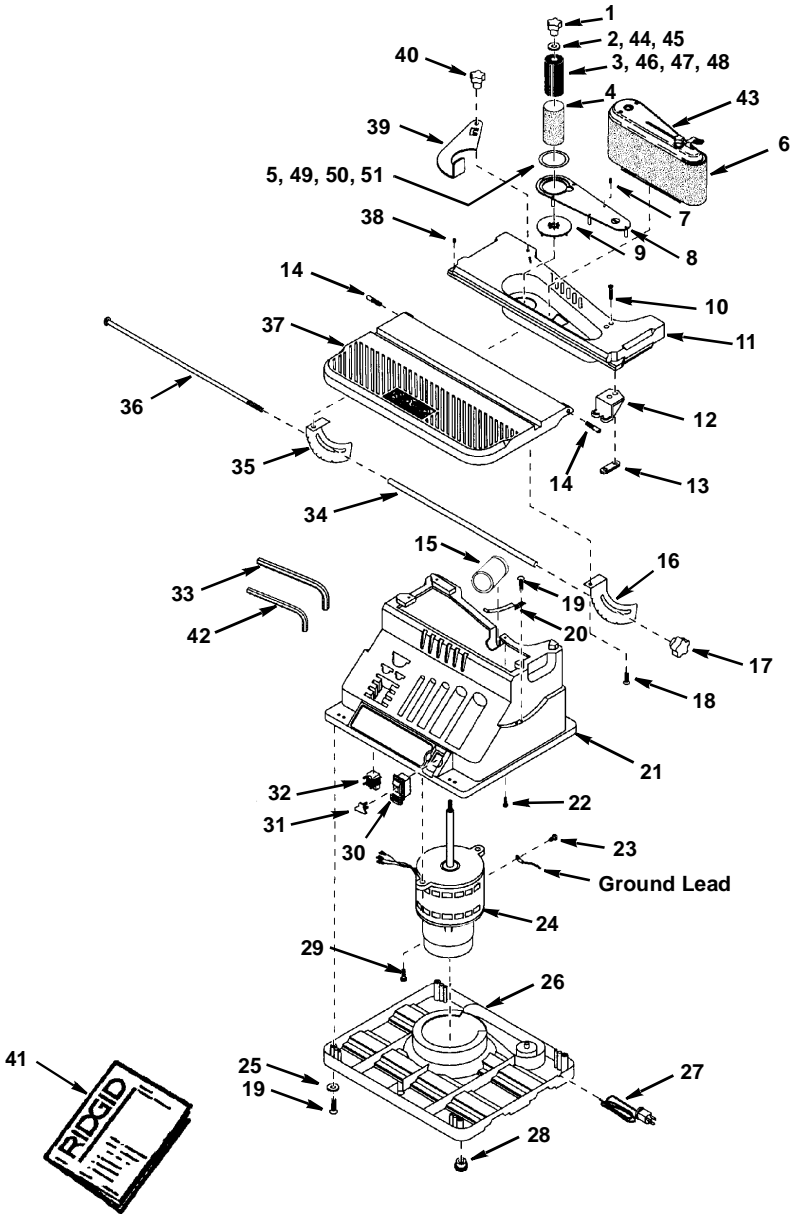

Repair Parts

Parts List For RIDGID Oscillating Edge Belt/Spindle Sander Model EB44241

RIDGID parts are available on-line at www.ridgidparts.com

Figure 1

Always order by Part Number—Not by Key Number

Key No.	Part No.	Description	Key No.	Part No.	Description
1	826358-1	Knob, Spindle	26	826801	Enclosure
2	805553-2	Washer 21/64 x 5/8 x 1/32	27	825854	Cord w/Plug
3	822304	Drum, Sanding 3/4"	28	819012	Foot
4	See pg. 29	†Drum, Sandpaper	29	9416630	Screw, Hex Hd Ty "T" 5/16-18 x 1
5	825808	Plate, Throat 2"	30	829785	Switch, Locking
6	See pg. 29	†Belt, Sanding 4" x 24"	31	AC1000	†Key, Switch
7	810993-2	Screw, Set Half Dog 10/32 x 1/2	32	817399-11	Relay
8	825841	Adapter, Throat Plate	33	37837	Wrench, Hex "L" 5/32
9	830291	Fan	34	825549	Spacer, Table Lock
10	805297-9	Screw, Flat Hd 1/4-20 x 5/8	35	825537-1	Bracket, Table Lock Left
11	825523	Table, Rear	36	825543	Bolt, Table Lock
12	825548	Plate, Wear	37	825524	Table, Front
13	825844	Nut, Special Twin 1/4-20	38	803309-2	Screw, Soc Set Lock 10-32 x 3/8
14	825842	Screw, Shoulder 1/4-20	39	825525	Plate, Stop
15	830246	Chute, Sawdust	40	825539-1	Knob 1/4-20
16	825537	Bracket, Table Lock	41	SP6496	Owners Manual
17	825852	Knob, 1/4-20 x 3/4	42	37836	Wrench, Hex "L" 3/32
18	159572-138	Screw, Wash/Hd Ty "T" 10-32 x 3/8	43	—	Belt Sanding Assembly (See Fig. 2)
19	808380-7	Screw, Pan Hd 10-14 x 1/2	44	805553-30	* Washer 5/8 x 1-3/4 x 1/8
20	825840	Spring, Detent	45	805553-24	Washer 21/64 x 7/8 x 3/64
21	830456	Base	46	822304-1	Drum, Sanding 1"
22	159572-186	Screw, Hex Hd Ty "T" 1/4-20 x 1	47	822304-2	Drum, Sanding 1-1/2"
23	824604	Screw, Hex Wash/Hd Ty "T" 8-32 x 3/8	48	822304-3	Drum, Sanding 2"
24	830290	• Motor/Drive Asm	49	825808-1	Plate, Throat 1-1/2"
25	805549-22	Washer 13/64 x 3/8 x .031	50	825808-2	Plate, Throat 1"
			51	825808-3	Plate, Throat 1/2"

* Standard Hardware Item - May be purchased locally

† These parts are available where you purchased your sander.

- Any attempt to repair this motor may create a hazard unless repair is done by a qualified service technician. Repair service is available at your nearest Authorized Service Center.

Repair Parts

Parts List For RIDGID Oscillating Edge Belt/ Spindle Sander Model EB44241

RIDGID parts are available on-line at www.ridgidparts.com
Figure 2

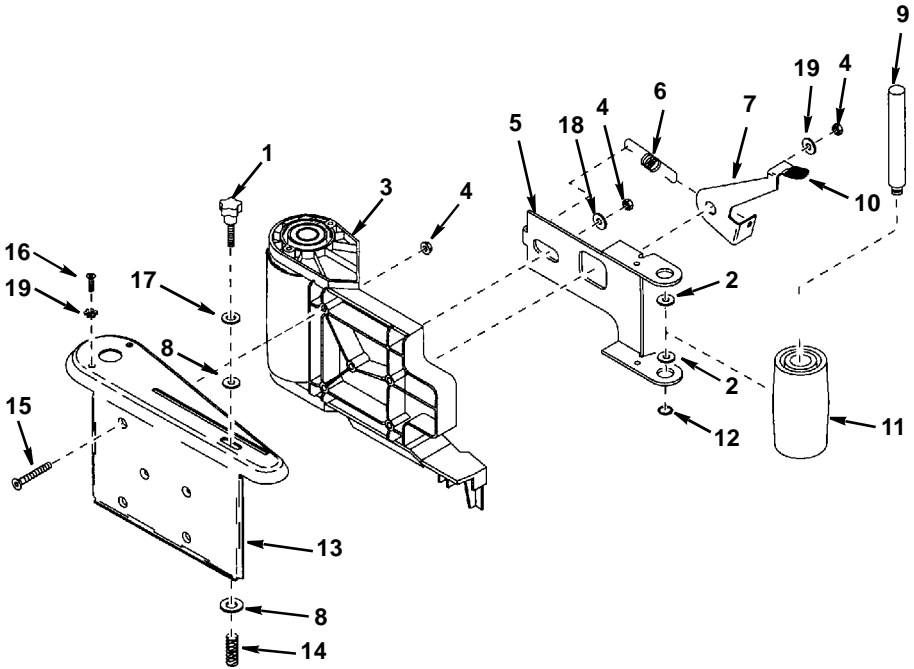

Always order by Part Number—Not by Key Number

Key No.	Part No.	Description	Key No.	Part No.	Description
1	825539	Knob 10-32 x 1-1/4	12	817453	Ring, Retaining 5160-50
2	830306	Washer 12 mm 1.0.	13	826802	Platen
3	830453	Drum/Drive Asm.	14	30521	Spring, Swivel
4	37482	Nut, Lock	15	821166-1	Screw, Flat Hd Hex 10/32 x 1-1/2
5	830305	Guide	16	809169-9	Screw, Pan Cr Ty T 8-32 x 3/4
6	825531	Spring, Extension	17	820175	Washer, Rubber
7	825529	Lever	18	9416712	* Washer 3/16 x 5/8 x 1/16
8	805549-4	* Washer 13/64 x 1/2 x 3/64	19	114603	* Lockwasher, Ext. #10
9	830304	Shaft, Idle			
10	826163-2	Cap, Grip			
11	830454	Drum, Idle Asm			

* Standard Hardware Item - May be purchased locally

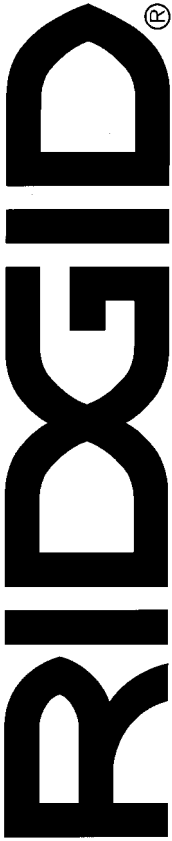

RIDGID® HAND HELD AND STATIONARY POWER TOOL LIMITED THREE YEAR WARRANTY AND 90 DAY SATISFACTION GUARANTEE POLICY

This product is manufactured under license from Ridgid, Inc. by One World Technologies, Inc.. All warranty communications should be directed to One World Technologies, Inc. at (toll free) 1-866-539-1710.

90-Day Satisfaction Guarantee Policy

During the first 90 days after the date of purchase, if you are dissatisfied with the performance of this Ridgid® tool for any reason, you may return the tool to the dealer from which it was purchased for a full refund or exchange. To receive a replacement tool you must present proof of purchase and return all original equipment packaged with the original product. The replacement tool will be covered by the limited warranty for the balance of the three year warranty period.

What is covered under the Limited Three Year Warranty

This warranty covers all defects in workmanship or materials in this RIDGID® tool for the three year period from the date of purchase. This warranty is specific to this tool. Warranties for other RIDGID® products may vary.

How to obtain service

To obtain service for this RIDGID® tool you must return it, freight prepaid, to an authorized RIDGID® service center for hand held and stationary power tools. You may obtain the location of the authorized service center nearest you by calling (toll free) 1-866-539-1710 or by logging on to the RIDGID® website at www.ridgidwoodworking.com. When requesting warranty service, you must present the proof of purchase documentation, which includes a date of purchase. The authorized service center will repair any faulty workmanship, and either repair or replace any defective part, at your option at no charge to you.

What is not covered

This warranty applies only to the original purchaser at retail and may not be transferred. This warranty only covers defects arising under normal usage and does not cover any malfunction, failure or defect resulting from misuse, abuse, neglect, alteration, modification or repair by other than authorized RIDGID® service center for hand held and stationary power tools. One World Technologies, Inc. makes no warranties, representations or promises as to the quality or performance of its power tools other than those specifically stated in this warranty.

Additional Limitations

To the extent permitted by applicable law, all implied warranties, including warranties of MERCHANTABILITY or FITNESS FOR A PARTICULAR PURPOSE, are disclaimed. Any implied warranties, including warranties of merchantability or fitness for a particular purpose, that cannot be disclaimed under state law are limited to three years from the date of purchase. One World Technologies, Inc. is not responsible for direct, indirect, incidental or consequential damages. Some states do not allow limitations on how long an implied warranty lasts and/or do not allow the exclusion or limitation of incidental or consequential damages, so the above limitations may not apply to you. This warranty gives you specific legal rights, and you may also have other rights which vary from state to state.

Catalog No. EB4424

Model No. EB44241 Serial No. _____

The model and serial numbers may be found on the back side of the base. You should record both model and serial number in a safe place for future use.

QUESTIONS OR COMMENTS?

CALL 1-866-539-1710

www.ridgidwoodworking.com

Please have your Model Number and Serial Number on hand when calling.

Free Manuals Download Website

<http://myh66.com>

<http://usermanuals.us>

<http://www.somanuals.com>

<http://www.4manuals.cc>

<http://www.manual-lib.com>

<http://www.404manual.com>

<http://www.luxmanual.com>

<http://aubethermostatmanual.com>

Golf course search by state

<http://golfingnear.com>

Email search by domain

<http://emailbydomain.com>

Auto manuals search

<http://auto.somanuals.com>

TV manuals search

<http://tv.somanuals.com>