



# AD8HR

AD CONVERTER WITH REMOTE PREAMP

## Owner's Manual

Thank you for choosing the Yamaha AD8HR AD converter with remote microphone preamp.

The AD8HR is an eight-channel AD converter equipped with remote microphone preamps that feature 96kHz, 24-bit linear AD conversion, 128-times oversampling, and a dynamic range of 110dB. Its input section features balanced XLR connectors, high-quality mic preamps, +48V phantom power, and support for both mic and line-level inputs. The output section supports the AES/EBU format and features a high sampling frequency of 88.2/96kHz. You can easily adjust the gain for each channel (in 1dB steps) and set up the high pass filter from the front panel. These settings are stored in the unit's backup memory, and are retained even after the power is turned off. In addition, a special protocol enables you to remotely control the unit from a connected computer or other device.

Please read this manual thoroughly before using the unit to take the greatest advantage of the AD8HR's extensive features for the longest period of time. After you read this manual, please keep it in a safe place.



# PRECAUTIONS

## PLEASE READ CAREFULLY BEFORE PROCEEDING

\* Please keep this manual in a safe place for future reference.



### WARNING

Always follow the basic precautions listed below to avoid the possibility of serious injury or even death from electrical shock, short-circuiting, damages, fire or other hazards. These precautions include, but are not limited to, the following:

#### Power supply/Power cord

- Only use the voltage specified as correct for the device. The required voltage is printed on the name plate of the device.
- Use only the supplied power cord.
- Do not place the power cord near heat sources such as heaters or radiators, and do not excessively bend or otherwise damage the cord, place heavy objects on it, or place it in a position where anyone could walk on, trip over, or roll anything over it.

#### Do not open

- Do not open the device or attempt to disassemble the internal parts or modify them in any way. The device contains no user-serviceable parts. If it should appear to be malfunctioning, discontinue use immediately and have it inspected by qualified Yamaha service personnel.

#### Water warning

- Do not expose the device to rain, use it near water or in damp or wet conditions, or place containers on it containing liquids which might spill into any openings.
- Never insert or remove an electric plug with wet hands.

#### If you notice any abnormality

- If the power cord or plug becomes frayed or damaged, or if there is a sudden loss of sound during use of the device, or if any unusual smells or smoke should appear to be caused by it, immediately turn off the power switch, disconnect the electric plug from the outlet, and have the device inspected by qualified Yamaha service personnel.
- If this device should be dropped or damaged, immediately turn off the power switch, disconnect the electric plug from the outlet, and have the device inspected by qualified Yamaha service personnel.



### CAUTION

Always follow the basic precautions listed below to avoid the possibility of physical injury to you or others, or damage to the device or other property. These precautions include, but are not limited to, the following:

#### Power supply/Power cord

- Remove the electric plug from the outlet when the device is not to be used for extended periods of time, or during electrical storms.
- When removing the electric plug from the device or an outlet, always hold the plug itself and not the cord. Pulling by the cord can damage it.

#### Location

- Before moving the device, remove all connected cables.
- Do not expose the device to excessive dust or vibrations, or extreme cold or heat (such as in direct sunlight, near a heater, or in a car during the day) to prevent the possibility of panel disfiguration or damage to the internal components.
- Do not place the device in an unstable position where it might accidentally fall over.
- Do not use the device in the vicinity of a TV, radio, stereo equipment, mobile phone, or other electric devices. Otherwise, the device, TV, or radio may generate noise.

#### Connections

- Before connecting the device to other devices, turn off the power for all devices. Before turning the power on or off for all devices, set all volume levels to minimum.

- Be sure to connect to a properly grounded power source. A ground screw terminal is provided on the rear panel for safely grounding the device and preventing electrical shock.

#### Handling caution

- Do not insert your fingers or hand in any gaps or openings on the device.
- Avoid inserting or dropping foreign objects (paper, plastic, metal, etc.) into any gaps or openings on the device. If this happens, turn off the power immediately and unplug the power cord from the AC outlet. Then have the device inspected by qualified Yamaha service personnel.
- Do not rest your weight on the device or place heavy objects on it, and avoid use excessive force on the buttons, switches or connectors.

#### Backup battery

- This device has a built-in backup battery. When you unplug the power cord from the AC outlet, the internal data is retained. However, if the backup battery fully discharges, this data will be lost. When the backup battery is running low, the GAIN display indicates "E1." In this case, immediately have qualified Yamaha service personnel replace the backup battery.

XLR-type connectors are wired as follows (IEC60268 standard): pin 1: ground, pin 2: hot (+), and pin 3: cold (-).

Yamaha cannot be held responsible for damage caused by improper use or modifications to the device, or data that is lost or destroyed.

Always turn the power off when the device is not in use.

The performance of components with moving contacts, such as switches, volume controls, and connectors, deteriorates over time. Consult qualified Yamaha service personnel about replacing defective components.

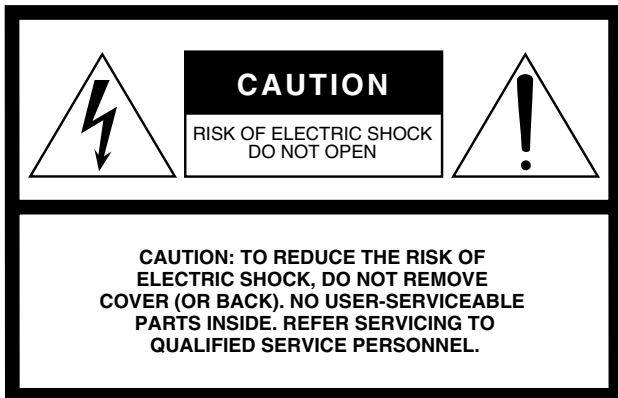

## Explanation of Graphical Symbols

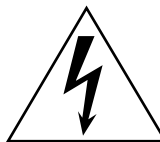

The lightning flash with arrowhead symbol within an equilateral triangle is intended to alert the user to the presence of uninsulated “dangerous voltage” within the product’s enclosure that may be of sufficient magnitude to constitute a risk of electric shock to persons.



The exclamation point within an equilateral triangle is intended to alert the user to the presence of important operating and maintenance (servicing) instructions in the literature accompanying the product.

The above warning is located on the top of the unit.

## IMPORTANT SAFETY INSTRUCTIONS

- 1 Read these instructions.
- 2 Keep these instructions.
- 3 Heed all warnings.
- 4 Follow all instructions.
- 5 Do not use this apparatus near water.
- 6 Clean only with dry cloth.
- 7 Do not block any ventilation openings. Install in accordance with the manufacturer’s instructions.
- 8 Do not install near any heat sources such as radiators, heat registers, stoves, or other apparatus (including amplifiers) that produce heat.
- 9 Do not defeat the safety purpose of the polarized or grounding-type plug. A polarized plug has two blades with one wider than the other. A grounding type plug has two blades and a third grounding prong. The wide blade or the third prong are provided for your safety. If the provided plug does not fit into your outlet, consult an electrician for replacement of the obsolete outlet.

### WARNING

TO REDUCE THE RISK OF FIRE OR ELECTRIC SHOCK, DO NOT EXPOSE THIS APPARATUS TO RAIN OR MOISTURE.

- 10 Protect the power cord from being walked on or pinched particularly at plugs, convenience receptacles, and the point where they exit from the apparatus.
- 11 Only use attachments/accessories specified by the manufacturer.
- 12 Use only with the cart, stand, tripod, bracket, or table specified by the manufacturer, or sold with the apparatus. When a cart is used, use caution when moving the cart/apparatus combination to avoid injury from tip-over.
- 13 Unplug this apparatus during lightning storms or when unused for long periods of time.
- 14 Refer all servicing to qualified service personnel. Servicing is required when the apparatus has been damaged in any way, such as power-supply cord or plug is damaged, liquid has been spilled or objects have fallen into the apparatus, the apparatus has been exposed to rain or moisture, does not operate normally, or has been dropped.



## FCC INFORMATION (U.S.A.)

### 1. IMPORTANT NOTICE: DO NOT MODIFY THIS UNIT!

This product, when installed as indicated in the instructions contained in this manual, meets FCC requirements. Modifications not expressly approved by Yamaha may void your authority, granted by the FCC, to use the product.

2. **IMPORTANT:** When connecting this product to accessories and/or another product use only high quality shielded cables. Cable/s supplied with this product **MUST** be used. Follow all installation instructions. Failure to follow instructions could void your FCC authorization to use this product in the USA.

3. **NOTE:** This product has been tested and found to comply with the requirements listed in FCC Regulations, Part 15 for Class “B” digital devices. Compliance with these requirements provides a reasonable level of assurance that your use of this product in a residential environment will not result in harmful interference with other electronic devices. This equipment generates/uses radio frequencies and, if not installed and used according to the instructions found in the users manual, may cause interference harmful to the operation of other electronic devices. Compliance with FCC regulations does

not guarantee that interference will not occur in all installations. If this product is found to be the source of interference, which can be determined by turning the unit “OFF” and “ON”, please try to eliminate the problem by using one of the following measures:

Relocate either this product or the device that is being affected by the interference.

Utilize power outlets that are on different branch (circuit breaker or fuse) circuits or install AC line filter/s.

In the case of radio or TV interference, relocate/reorient the antenna. If the antenna lead-in is 300 ohm ribbon lead, change the lead-in to co-axial type cable.

If these corrective measures do not produce satisfactory results, please contact the local retailer authorized to distribute this type of product. If you can not locate the appropriate retailer, please contact Yamaha Corporation of America, Electronic Service Division, 6600 Orangethorpe Ave, Buena Park, CA90620

The above statements apply **ONLY** to those products distributed by Yamaha Corporation of America or its subsidiaries.

\* This applies only to products distributed by YAMAHA CORPORATION OF AMERICA.

(class B)

## IMPORTANT NOTICE FOR THE UNITED KINGDOM

### Connecting the Plug and Cord

**WARNING:** THIS APPARATUS MUST BE EARTHED  
IMPORTANT. The wires in this mains lead are coloured in accordance with the following code:

GREEN-AND-YELLOW : EARTH  
BLUE : NEUTRAL  
BROWN : LIVE

As the colours of the wires in the mains lead of this apparatus may not correspond with the coloured markings identifying the terminals in your plug proceed as follows:

The wire which is coloured GREEN-and-YELLOW must be connected to the terminal in the plug which is marked by the letter E or by the safety earth symbol ⊕ or colored GREEN or GREEN-and-YELLOW.

The wire which is coloured BLUE must be connected to the terminal which is marked with the letter N or coloured BLACK.

The wire which is coloured BROWN must be connected to the terminal which is marked with the letter L or coloured RED.

• This applies only to products distributed by Yamaha-Kemble Music (U.K.) Ltd. (3 wires)

## ADVARSEL!

Lithiumbatteri—Eksplønsionsfare ved fejlagtig håndtering. Udskiftning må kun ske med batteri af samme fabrikat og type. Levér det brugte batteri tilbage til leverandoren.

## VARNING

Eksplønsionsfara vid felaktigt batteribyte. Använd samma batterityp eller en ekvivalent typ som rekommenderas av apparattillverkaren. Kassera använt batteri enligt fabrikantens instruktion.

## VAROITUS

Paristo voi räjähtää, jos se on virheellisesti asennettu. Vaihda paristo ainoastaan laitevalmistajan suosittelemaan tyyppiin. Hävitä käytetty paristo valmistajan ohjeiden mukaisesti.

(lithium caution)

## NEDERLAND / THE NETHERLANDS

- Dit apparaat bevat een lithium batterij voor geheugen back-up.
- This apparatus contains a lithium battery for memory back-up.
- Raadpleeg uw leverancier over de verwijdering van de batterij op het moment dat u het apparaat aan het einde van de levensduur afdankt of de volgende Yamaha Service Afdeling:  
Yamaha Music Nederland Service Afdeling  
Kanaalweg 18-G, 3526 KL UTRECHT  
Tel. 030-2828425
- For the removal of the battery at the moment of the disposal at the end of the service life please consult your retailer or Yamaha Service Center as follows:  
Yamaha Music Nederland Service Center  
Address : Kanaalweg 18-G, 3526 KL UTRECHT  
Tel : 030-2828425
- Gooi de batterij niet weg, maar lever hem in als KCA.
- Do not throw away the battery. Instead, hand it in as small chemical waste.

(lithium disposal)

## Table of Contents

|   |          |   |           |
|---|----------|---|-----------|
| <b>Part Names and Functions .....</b>       | <b>5</b> | <b>Connection Examples.....</b>           | <b>10</b> |
| Front Panel .....                           | 5        | AES/EBU Connections .....                 | 10        |
| Rear Panel .....                            | 6        | AD8HR Daisy Chain Connection .....        | 10        |
| <b>Basic Operations .....</b>               | <b>7</b> | <b>Wordclocks .....</b>                   | <b>11</b> |
| Selecting the Wordclock.....                | 7        | AES/EBU Connections.....                  | 11        |
| Setting the Phantom Power .....             | 7        | WORD CLOCK jack connection .....          | 11        |
| Adjusting the Gain .....                    | 7        | <b>Appendix .....</b>                     | <b>12</b> |
| Adjusting the Gain Trim (Gain Correction) . | 7        | General Specifications.....               | 12        |
| Setting the High Pass Filter.....           | 8        | I/O Characteristics .....                 | 12        |
| Copying the Channel Settings.....           | 8        | Electrical Characteristics.....           | 13        |
| Selecting the AES/EBU Format.....           | 8        | Error Messages .....                      | 14        |
| Adjusting the LED Brightness .....          | 9        | DIGITAL OUT A/B Pin Assignment Table .... | 14        |
| Panel Operation Lock.....                   | 9        | HA REMOTE Pin Assignment Table.....       | 15        |
| Initializing the Memory .....               | 9        | Dimensions .....                          | 15        |
| Remote Control .....                        | 9        |   |           |

\* All illustrations in this manual are intended to explain procedures. Therefore, some illustrations may appear different than your unit.

\* All names of companies and products that appear in this manual are trademarks or registered trademarks of the respective owners.

Yamaha Proaudio website:  
<http://www.yamahaproaudio.com/>

# Part Names and Functions

## Front Panel

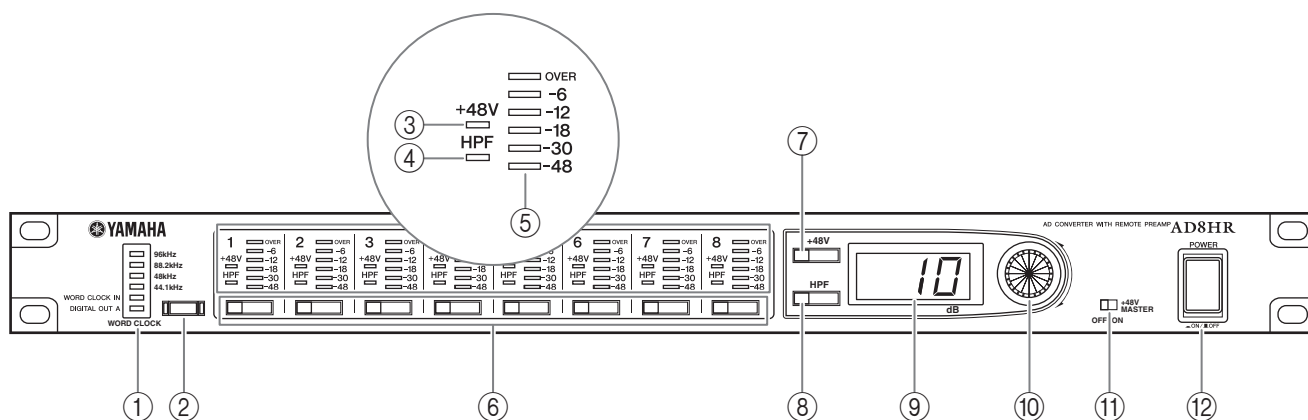

### ① WORD CLOCK indicators

These indicators indicate the currently selected wordclock source. If the unit is not locking to the selected wordclock source, the corresponding wordclock source indicator flashes.

### ② [WORD CLOCK] button

This button enables you to select the wordclock source from 44.1kHz, 48kHz, 88.2kHz, 96kHz, WORD CLOCK IN, and DIGITAL OUT A (See page 7.)

### ③ +48V indicators

These indicators indicate the on/off status of the +48 phantom power of the corresponding channels.

### ④ HPF indicators

These indicators indicate the on/off status of the high pass filter of the corresponding channels.

### ⑤ Level meters

These meters indicate the corresponding channel output level in six steps.

### ⑥ Channel Select buttons

These buttons enable you to select channels to edit.

### ⑦ [+48V] button

This button turns the +48 phantom power of the selected channels on or off (See page 7.) The button indicator lights up when the +48V phantom power of the selected channels is turned on.

### ⑧ [HPF] button

This button turns the high pass filter of the selected channels on or off (See page 8.) The button indicator lights up when the high pass filter of the selected channels is turned on.

### ⑨ Gain display

This 3-digit, 7-segment display indicates the gain of the currently selected channel.

### ⑩ Gain control

This control sets the gain of the selected channel.

### ⑪ [+48V MASTER] switch

This switch turns the +48V phantom master power on or off.

### ⑫ [POWER] switch

This switch turns the power to the AD8HR on or off. The gain and high pass filter settings are stored even after you turn off the power to the unit.

#### NOTE:

To avoid loud noise from the speakers, turn on the power first to the connected devices that are closest to the sound source.

Example: Sound source → AD8HR → Mixer → Power amplifier

To turn off the power to the system, reverse the order described above.

## Rear Panel

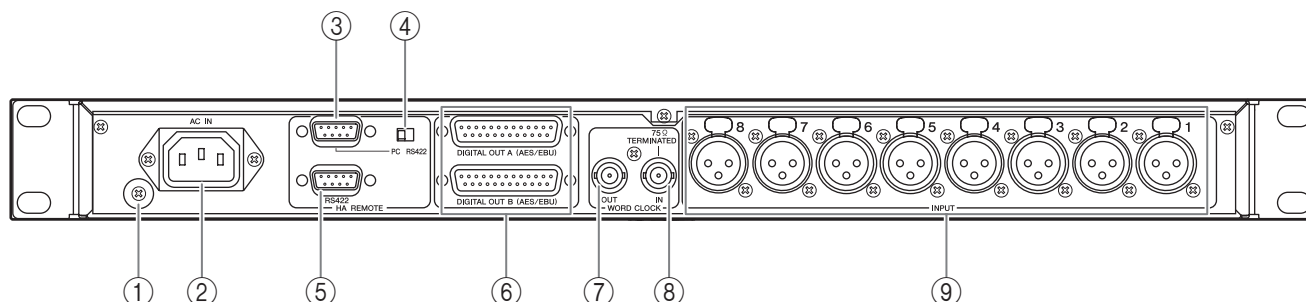

### ① **Grounding screw**

For safety, use this screw to ground the AD8HR. The included power cable has a three-pin plug. If the AC outlet is grounded, the AD8HR will be grounded correctly via the power cable. If the AC outlet does not provide a suitable ground, this screw must be connected to a suitable ground point. Grounding is also an effective method for eliminating hum, interference, and other noise.

### ② **[AC IN] connector**

Connect the included power cable here. First, connect the power cable to the AD8HR, then insert the power cable plug into the AC outlet.



*Be sure to use the included power cable. Use of other cables may result in malfunction, heat generation, or fire.*

### ③ **[HA REMOTE] connector 1**

This D-sub 9-pin connector is used to connect a computer or Yamaha PM5D Digital Console or DM2000 to control the AD8HR remotely. In a multiple AD8HR system, connect an AD8HR to [HA REMOTE] connector 1 on an additional AD8HR.

#### **NOTE:**

*Please visit the following Yamaha website for the latest information about the devices that can control the AD8HR remotely.*

*<http://www.yamahaproaudio.com/>*

### ④ **[PC RS422] switch**

If you connect a computer to [HA REMOTE] connector 1, set this switch to PC. If you connect a Yamaha PM5D or DM2000, or an additional AD8HR in a multiple AD8HR system, to [HA REMOTE] connector 1, set this switch to RS422.

### ⑤ **[HA REMOTE] connector 2**

In a multiple AD8HR system, connect one AD8HR to this D-sub 9-pin connector on another AD8HR.

### ⑥ **[DIGITAL OUT A/B] connector**

These D-sub 25-pin connectors output AES/EBU format digital audio. In Double Speed mode, each connector outputs digital audio data routed from Channels 1–8. In Double Channel mode, the [DIGITAL OUT A] connector outputs digital audio data routed from Channels 1–4, and the [DIGITAL OUT B] connector outputs digital audio data routed from Channels 5–8.

### ⑦ **[WORD CLOCK OUT] connector**

This BNC connector outputs a wordclock signal.

### ⑧ **[WORD CLOCK IN] connector**

This BNC connector inputs a wordclock signal. This connector is terminated at 75Ω.

### ⑨ **INPUT 1–8 connectors**

These balanced XLR-3-31-type connectors are used to input analog signals to the corresponding channels.

# Basic Operations

## Selecting the Wordclock

You can select from the following wordclock source options: internal clock (44.1kHz, 48kHz, 88.2kHz, and 96kHz), WORD CLOCK IN, or DIGITAL OUT A.

- 1 Press the [WORD CLOCK] button repeatedly to select the wordclock source.**  
The indicator of the selected wordclock flashes rapidly.
- 2 While the indicator is flashing rapidly, press the [WORD CLOCK] button again.**  
The AD8HR switches to the selected wordclock source and the flashing wordclock indicator stays lit. The indicator of the previously-selected wordclock source turns off.  
If you do not press the [WORD CLOCK] button again before the indicator stops flashing (it will flash for five seconds), the new selection is cancelled and the previous wordclock is selected.  
If the AD8HR is not locking to the selected wordclock source, the corresponding wordclock source indicator flashes.

### NOTE:

The only word clock source available via the AES/EBU connection is the IN signal of DIGITAL OUT A channels 1/2.

## Setting the Phantom Power

Follow the steps below to turn the +48V phantom power for each channel on or off.

### NOTE:

You can also turn the phantom power for all channels on or off simultaneously (not individual channels) using the [+48V MASTER] switch. When the [+48V MASTER] switch is turned off, the phantom power is not supplied to channels even if the [+48V] button is turned on for the channels.

- 1 Press the Channel Select buttons to select the channels.**  
The selected channels' Channel Select button indicators light up. The channel +48V indicator lights up when the +48V phantom power for the selected channels is turned on.
- 2 Press the [+48V] button.**  
If phantom power for the selected channels was off before the operation, the [+48V] button indicator starts flashing rapidly. If phantom power for the selected channels was on before the operation, the [+48V] button indicator and the phantom power for the selected channels turns off.

- 3 While the indicator is flashing rapidly, press the [+48V] button again.**  
The phantom power for the selected channels turns on, and the corresponding channel [+48V] indicators and the [+48V] button indicator light up.  
If you do not press the [+48V] button again before the indicator stops flashing (it will flash for five seconds), the setting is cancelled.

## Adjusting the Gain

Follow the steps below to adjust the channel gain in 1dB steps.

- 1 Press the Channel Select button to select a channel.**  
The selected channel's Channel Select button indicator lights up and the Gain display indicates the gain value.
- 2 Rotate the Gain control to adjust the gain**  
You can adjust the gain in the range of 10dB through -62dB in 1dB steps.

### NOTE:

While adjusting the gain, you may notice that the sound is briefly interrupted. This is not a malfunction. The internal setting is switched in steps of 6 dB, and the sound is momentarily muted so that the noise will not be created during the switching operation.

## Adjusting the Gain Trim (Gain Correction)

Follow the steps below to correct the channel gain in 0.1dB steps. The output level of each channel has been calibrated in the factory. Typically, you will not have to correct the setting.

### NOTE:

In the factory, the level has been set to the optimum value and the initial level varies with each channel. This setting is reset to the factory value when you initialize the backup memory.

- 1 Press and hold down the desired Channel Select button for more than two seconds.**  
The Channel Select button indicator flashes and the Gain display indicates the gain trim value.
- 2 Rotate the Gain control to adjust the gain trim value.**  
You can adjust the gain trim value in the range of -1.5dB through +1.5dB in 0.1dB steps.
- 3 Press the same Channel Select button again.**  
The Channel Select button indicator lights up and the Gain display indicates the gain value.



## Setting the High Pass Filter

Each channel features a high pass filter (12dB/octave) that you can turn on or off. You can set individual cut-off frequencies for each channel's high pass filter.

- 1 Press the Channel Select button to select a channel.**  
The selected channels' Channel Select button indicators light up. The channel HPF indicator lights up when the high pass filter for the selected channels is turned on.
- 2 Press the [HPF] button to turn the channel high pass filter on or off.**
- 3 To change the cut-off frequency, press and hold down the [HPF] button for more than two seconds.**  
The [HPF] button indicator flashes rapidly and the Gain display indicates the cut-off frequency.
- 4 Rotate the Gain control to set the cut-off frequency.**  
You can set the cut-off frequency in the range of 20Hz through 600Hz (in 60 steps).
- 5 Press the [HPF] button again.**  
The [HPF] button indicator returns to the previous (on or off) status and the Gain display indicates the gain value.

## Copying the Channel Settings

Follow the steps below to copy channel settings to another channel. You can copy the following settings: channel gain, high pass filter on/off, cut-off frequency, and phantom power on/off. The gain trim value will not be copied.

- 1 Press and hold down the Channel Select button of the copy source channel, and press the Channel Select button of the copy destination channel.**  
The channel settings will be copied. To copy the same channel settings to a different channel, continue holding down the Channel Select button of the copy source channel, and press the Channel Select button of the target channel.

## Selecting the AES/EBU Format

You can select Double Speed mode (AE1) or Double Channel mode (AE2) for the AES/EBU format.

### ■ Double Speed Mode

In Double Speed mode, digital audio data is transmitted at the current higher sampling rate (i.e., 88.2kHz or 96kHz). Select this mode if the devices that support the higher sampling rates receive data.

The [DIGITAL OUT A] and [DIGITAL OUT B] connectors each output digital audio data routed from Channels 1–8.

### ■ Double Channel Mode

In Double Channel mode, digital audio data is transmitted as mono signals at a sampling rate that is exactly half (44.1/48kHz) the current higher sampling rate. The data is handled by two channels. This is useful when you wish to transfer data from the AD8HR running at a higher sampling rate to legacy 44.1/48kHz digital devices.

The [DIGITAL OUT A] connector outputs digital audio data routed from Channels 1–4, and the [DIGITAL OUT B] connector outputs digital audio data routed from Channels 5–8. However, if the AD8HR is running at a sampling rate of 44.1/48kHz, each connector outputs digital audio data routed from Channels 1–8.

If the wordclock master is DIGITAL OUT A, the AD8HR will run at a clock rate that is twice (88.2/96kHz) the incoming clock (44.1/48kHz).

- 1 Turn off the power to the AD8HR.**
- 2 Press and hold down the [WORD CLOCK] button and the Channel Select button of Channel 1 or 2, then turn on the [POWER] switch.**  
Pressing the Channel Select button of Channel 1 will select Double Speed mode (AE1). Pressing the Channel Select button of Channel 2 will select Double Channel mode (AE2). At the same time, the Gain display will indicate the selected mode (AE1 or AE2) for one second.



## Adjusting the LED Brightness

Follow the steps below to adjust the brightness of the front panel LED and Gain display.

- 1 While pressing and holding down the Channel Select button of Channel 8, rotate the Gain control to adjust the brightness.

You can adjust the brightness in seven steps.

## Panel Operation Lock

You can lock the buttons and controls on the front panel to avoid any trouble due to unauthorized or unintentional operation. Note that you cannot lock the operation from the remote control.

- 1 Press the [WORD CLOCK] button, [+48V] button, and [HPF] button simultaneously.

This will turn the Panel Operation Lock function on or off. If the Panel Operation Lock function is turned on, the Gain display flashes when you operate the front panel, but you cannot change the settings.

## Initializing the Memory

Follow the steps below to initialize the backup memory to reset to the factory value.

- 1 Turn off the power to the AD8HR.
- 2 While pressing and holding down the Channel Select button of Channel 4 and the [+48V] button, turn on the [POWER] switch.

The backup memory will be initialized.

The backup memory stores the following settings.

| Channel settings   | Global settings   |
|--|---|
| <ul style="list-style-type: none"> <li>• Phantom power on/off</li> <li>• Gain</li> <li>• Gain trim</li> <li>• High pass filter on/off</li> <li>• High pass filter cut-off frequency</li> </ul> | <ul style="list-style-type: none"> <li>• Wordclock</li> <li>• AES/EBU format</li> <li>• LED brightness</li> <li>• Panel Operation Lock setting</li> </ul> |

## Remote Control

A special protocol enables you to control the AD8HR from a computer or Yamaha PM5D or DM2000 that is connected to [HA REMOTE] connector 1. You can also remotely control up to 255 AD8HRs that are connected to one another.

When each AD8HR receives control signals, the Gain display indicates the ID number of the corresponding unit. This is useful when you wish to identify each of multiple AD8HRs that are connected in a system. When you operate the panel on the unit, its ID number on the Gain display disappears. The ID number of the AD8HRs is determined based on the connection order in the daisy chain.

You can also create a daisy chain connection that mixes AD8HRs and Yamaha AD824 AD converters. However, in such a system, any AD8HR that is connected after any AD824 unit (when seen from the host device; e.g., computer) will be recognized as an AD824, and you will be unable to control the following functionality on these AD8HR units. For this reason, we recommend that you connect all AD8HR units closer to the host than any AD824 unit.

- High pass filter on/off and cutoff frequency cannot be controlled
- Gain adjustment will be in 6 dB steps
- [+48V MASTER] switch on/off status cannot be monitored

If a computer is connected to [HA REMOTE] connector 1, set the [PC RS422] switch to PC. If you connect a Yamaha PM5D or DM2000, or another AD8HR in a multiple AD8HR system, to [HA REMOTE] connector 1, set this switch to RS422.

### NOTE:

- If you are remotely controlling the AD8HR from a device that supports only the AD824, the device will recognize all AD8HRs as AD824s.
- When remotely controlling the AD8HR from a Yamaha DM2000/DM1000, all AD8HR units may be recognized as AD824 units and some functionality may be limited unless the DM2000/DM1000 firmware is V2.0 or later. For the latest information, refer to the following website.  
<http://www.yamahaproaudio.com/>
- If you are connecting the [HA REMOTE] connectors on two AD8HRs to each other, be careful to avoid loop connection.

# Connection Examples

## AES/EBU Connections

Use a D-sub 25-pin AES/EBU cable to connect a digital audio device that supports the AES/EBU format. To connect a Yamaha PM5D or DM2000 to the AD8HR, first you must install an optional I/O card (MY8-AE, MY8-AE96S, MY8-AE96, or MY16-AE) in the PM5D or DM2000.

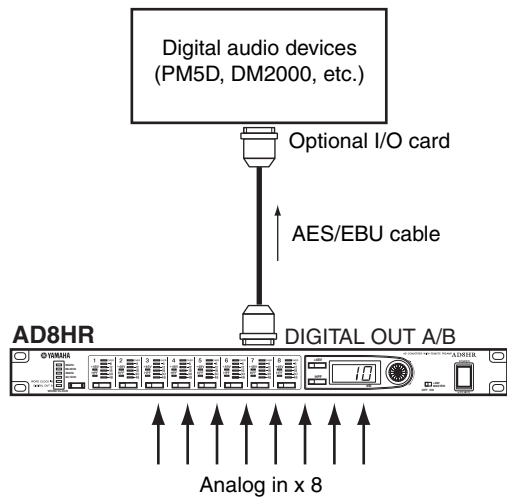

## AD8HR Daisy Chain Connection

You can connect multiple AD8HRs to a Yamaha PM5D or DM2000. Connect [HA REMOTE] connector 1 of the first AD8HR to the COM connector of the DM2000, and connect [HA REMOTE] connector 2 to [HA REMOTE] connector 1 of the second AD8HR. Set the [PC RS422] switches on both AD8HRs to RS422. Specify the DM2000 as the wordclock master, and set the wordclock source on the AD8HR to DIGITAL OUT A.

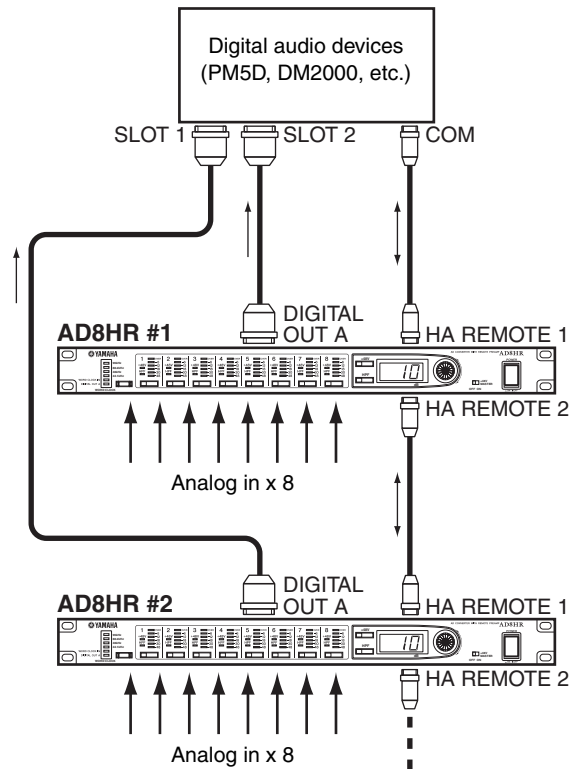

# Wordclocks

For proper AD conversion and digital audio data transmission and reception, the D8HRs and external digital audio devices must lock to an identical wordclock. The AD8HR is capable of transmitting a wordclock signal of 44.1kHz, 48kHz, 88.2kHz, and 96kHz, you can use the AD8HR as the wordclock master and the external devices as wordclock slaves. The AD8HR can also lock to the wordclock signal received at the [DIGITAL OUT A] connector or [WORD CLOCK IN] connector.

## AES/EBU Connections

Use an AES/EBU cable to transmit digital audio data and receive a wordclock signal on the AD8HR.

**NOTE:** \_\_\_\_\_  
*In Double Channel mode, the AD8HR will run at a clock rate that is twice (88.2/96kHz) the clock (44.1/48kHz) received at the [DIGITAL OUT A] connector. In Double Speed mode, the AD8HR will run at a clock rate that is the same as the wordclock (88.2/96kHz) received at the [DIGITAL OUT A] connector.*

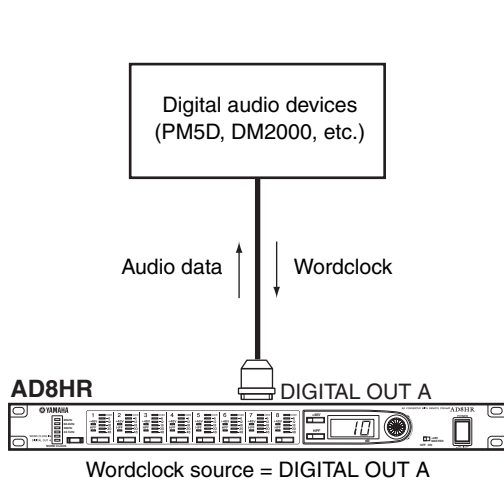

## WORD CLOCK jack connection

The AD8HR can receive wordclock signals at the [WORD CLOCK IN] connector. The [WORD CLOCK IN] connector and [WORD CLOCK OUT] connector can also be connected in series to allow multiple AD8HR units to receive a wordclock signal.

The AD8HR's [WORD CLOCK IN] connector is terminated at 75 ohms. Do not use a "T" connector to make connections.

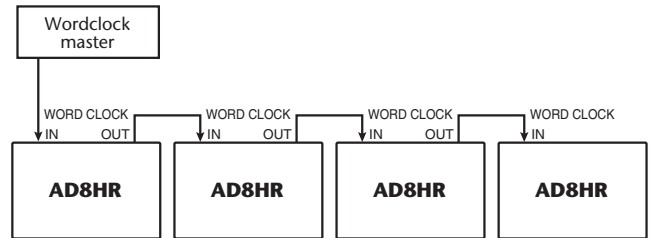

# Appendix

## General Specifications

### ■ Analog Input

INPUT 1–8  
 XLR-3-31 Balanced  
 AD converter 24-bit linear  
 128-times Oversampling

### ■ Digital Output

DIGITAL OUT A, B  
 D-Sub 25-pin Balanced

### ■ Connectors

WORD CLOCK IN (75Ω Auto Terminated): BNC  
 WORD CLOCK OUT: BNC  
 HA REMOTE (PC-RS422): D-Sub 9-pin with PC-RS422 switch  
 HA REMOTE (RS422): D-Sub 9-pin

### ■ Controls

+48V Master Switch  
 GAIN/DATA encoder

### ■ Keys

[WORD CLOCK]  
 [SELECT1]–[SELECT8]  
 [+48V]  
 [HPF]

### ■ LEDs

WORD CLOCK [44.1kHz]/[48kHz]/[88.2kHz]/[96kHz]  
 /[WORD CLOCK IN]/[DIGITAL OUT A]  
 LEVEL METER 1–8 8x6 Segment  
 SELECT 1–8  
 +48V 1–8, Selected Channel  
 HPF 1–8, Selected Channel  
 GAIN/DATA Display 7seg x3

### ■ Functions

HPF Frequency 20Hz–600Hz  
 INPUT GAIN TRIM –1.5 dB to 1.5 dB (0.1 dB step)  
 AES/EBU Higher Sampling Rate Data Output Format  
 Double Speed / Double Channel  
 Panel Lock  
 Panel Brightness 7 steps

### ■ Miscellaneous

Power Requirements U.S./Canada: 120 V 35 W, 60 Hz  
 Others: 230 V 35 W, 50 Hz  
 Dimensions (HxDxW) 45 x 383.5 x 480 mm  
 Net Weight 5 kg  
 Operation free-air temperature range  
 5 to 40 °C  
 Storage temperature –20 to 60 °C  
 Accessories AC Cable  
 Rubber Feet x 4  
 Owner's Manual

## I/O Characteristics

### Analog Input Specifications

| Input Terminals | GAIN   | Actual Load Impedance | For Use With Nominal           | Input level      |                   | Connector                     |
|-----------------|--------|-----------------------|--------------------------------|------------------|-------------------|-------------------------------|
|                 |        |                       |                                | Nominal          | Max. before clip  |                               |
| INPUT 1–8       | –62 dB | 3k Ω                  | 50~600 Ω Mics &<br>600 Ω Lines | –62 dBu (615 μV) | –42 dBu (6.15 mV) | XLR-3-31 type<br>(Balanced)*1 |
|                 | +10 dB |                       |                                | +10 dBu (2.45 V) | +30 dBu (24.5 V)  |                               |

\*1. XLR-3-31 type connectors are balanced. (1=GND, 2=HOT, 3=COLD)

\*2. In these specifications, when dBu represents a specific voltage, 0dBu is referenced to 0.775 Vrms.

\*3. AD converters are 24-bit linear, 128-times oversampling.

### Digital I/O Specifications

| Input/Output Terminals                          | Format  | Level     | Connector in Console |
|---|---------|-----------|----------------------|
| Input 1/2 (word clock only)*1<br>Output 1–8 x 2 | AES/EBU | RS422     | D-SUB 25p Female     |
| HA REMOTE x 2                                   | —       | RS422     | D-SUB 9p Male        |
| WORD CLOCK IN                                   | —       | TTL / 75Ω | BNC                  |
| WORD CLOCK OUT                                  | —       | TTL / 75Ω | BNC                  |

\*1. Input 1/2 on DIGITAL OUT A can be selected for word clock master.

\*2. Fs= 44.1, 48, 88.2 and 96 kHz is supported.

\*3. Double Channel mode is supported (Fs= 88.2, 96 kHz).

\*4. When locked to the word clock received via WORD CLOCK IN, the word clock will be output from WORD CLOCK OUT.

## Electrical Characteristics

Measured at DIGITAL OUT. Output impedance of signal generator: 150Ω.

### ■ Frequency Response

$f_s=44.1\text{kHz}$  or  $48\text{kHz}$  @20Hz–20kHz, with reference to  $-1\text{dBfs}$  @1kHz

| Input     | Output          | Conditions            | MIN  | TYP | MAX | UNITS |
|-----------|-----------------|-----------------------|------|-----|-----|-------|
| INPUT 1–8 | DIGITAL OUT 1–8 | GAIN: $-62\text{ dB}$ | -3   |     | 1   | dB    |
| INPUT 1–8 | DIGITAL OUT 1–8 | GAIN: $+10\text{ dB}$ | -1.5 |     | 1   | dB    |

$f_s=88.2\text{kHz}$  or  $96\text{kHz}$  @20Hz–40kHz, with reference to  $-1\text{dBfs}$  @1kHz

| Input     | Output          | Conditions            | MIN  | TYP | MAX | UNITS |
|-----------|-----------------|-----------------------|------|-----|-----|-------|
| INPUT 1–8 | DIGITAL OUT 1–8 | GAIN: $-62\text{ dB}$ | -3   |     | 1   | dB    |
| INPUT 1–8 | DIGITAL OUT 1–8 | GAIN: $+10\text{ dB}$ | -1.5 |     | 1   | dB    |

### ■ Gain Error @1kHz

| Input     | Output          | Conditions                             | MIN | TYP | MAX | UNITS |
|-----------|-----------------|--|-----|-----|-----|-------|
| INPUT 1–8 | DIGITAL OUT 1–8 | GAIN: $-62\text{dB}$ to $+10\text{dB}$ | -1  |     | 1   | dB    |

### ■ Total Harmonic Distortion

$f_s=44.1\text{kHz}$  or  $48\text{kHz}$

| Input     | Output          | Conditions  | MIN | TYP | MAX  | UNITS |
|-----------|-----------------|---|-----|-----|------|-------|
| INPUT 1–8 | DIGITAL OUT 1–8 | $-1\text{ dBfs}$ output @1kHz GAIN: $-62\text{ dB}$ |     |     | 0.05 | %     |
| INPUT 1–8 | DIGITAL OUT 1–8 | $-1\text{ dBfs}$ output @1kHz GAIN: $+10\text{ dB}$ |     |     | 0.01 | %     |

$f_s=88.2\text{kHz}$  or  $96\text{kHz}$

| Input     | Output          | Conditions  | MIN | TYP | MAX  | UNITS |
|-----------|-----------------|---|-----|-----|------|-------|
| INPUT 1–8 | DIGITAL OUT 1–8 | $-1\text{ dBfs}$ output @1kHz GAIN: $-62\text{ dB}$ |     |     | 0.05 | %     |
| INPUT 1–8 | DIGITAL OUT 1–8 | $-1\text{ dBfs}$ output @1kHz GAIN: $+10\text{ dB}$ |     |     | 0.01 | %     |

### ■ Hum & Noise

$f_s=44.1\text{kHz}$ ,  $48\text{kHz}$ ,  $88.2\text{kHz}$  or  $96\text{kHz}$

| Input     | Output          | Conditions                                | MIN | TYP  | MAX | UNITS |
|-----------|-----------------|---|-----|------|-----|-------|
| INPUT 1–8 | DIGITAL OUT 1–8 | $R_s=150\ \Omega$ , GAIN: $-62\text{ dB}$ |     | -80  |     | dBfs  |
| INPUT 1–8 | DIGITAL OUT 1–8 | $R_s=150\ \Omega$ , GAIN: $+10\text{ dB}$ |     | -110 |     | dBfs  |

\* Hum & Noise are measured with an A-weighting filter.

### ■ EIN Measured with DA824 EIN=Equivalent Input Noise

| Input     | Output          | Conditions                                | MIN | TYP | MAX  | UNITS |
|-----------|-----------------|---|-----|-----|------|-------|
| INPUT 1–8 | DIGITAL OUT 1–8 | $R_s=150\ \Omega$ , GAIN: $-62\text{ dB}$ |     |     | -128 | dB    |

\* EIN is measured with a 6 dB/octave filter @12.7 kHz; equivalent to a 20 kHz filter with infinite dB/octave attenuation.

### ■ Dynamic Range

| Input     | Output          | Conditions            | MIN | TYP | MAX | UNITS |
|-----------|-----------------|-----------------------|-----|-----|-----|-------|
| INPUT 1–8 | DIGITAL OUT 1–8 | GAIN: $+10\text{ dB}$ |     | 110 |     | dB    |

\* Dynamic Range is measured with an A-weighting filter.

### ■ Crosstalk @1kHz

| From/To | To/From           | Conditions                           | MIN | TYP | MAX | UNITS |
|---------|-------------------|--------------------------------------|-----|-----|-----|-------|
| CH N    | CH (N-1) or (N+1) | adjacent inputs GAIN: $+10\text{dB}$ |     |     | -80 | dB    |

### ■ Phantom Voltage

| Output    | Conditions          | MIN | TYP | MAX | UNITS |
|-----------|---------------------|-----|-----|-----|-------|
| INPUT 1–8 | hot & cold: No load | 46  | 48  | 50  | V     |

## ■ LED Level Meter

| Input     | Output          | Conditions        | MIN | TYP | MAX | UNITS |
|-----------|-----------------|-------------------|-----|-----|-----|-------|
| INPUT 1–8 | DIGITAL OUT 1–8 | OVER red LED: ON  |     | 0   |     | dBFs  |
|           |                 | –6 amber LED: ON  |     | –6  |     | dBFs  |
|           |                 | –12 amber LED: ON |     | –12 |     | dBFs  |
|           |                 | –18 amber LED: ON |     | –18 |     | dBFs  |
|           |                 | –30 green LED: ON |     | –30 |     | dBFs  |
|           |                 | –48 green LED: ON |     | –48 |     | dBFs  |

| Parameter                      |   | Conditions                    | MIN   | TYP  | MAX    | UNITS |
|--------------------------------|---|-------------------------------|-------|------|--------|-------|
| Sampling Frequency             | Frequency Range                           | Normal Rate                   | 39.69 |      | 50.88  | kHz   |
|                                |   | Double Rate                   | 79.38 |      | 101.76 | kHz   |
|                                | Jitter of PLL                             | DIGITAL IN fs=44.1kHz         |       |      | 10     | ns    |
|                                |   | DIGITAL IN fs=48 kHz          |       |      | 10     | ns    |
|                                |   | DIGITAL IN fs=39.69–50.88 kHz |       |      | 20     | ns    |
|                                |   | DIGITAL IN fs=88.2 kHz        |       |      | 10     | ns    |
|                                |   | DIGITAL IN fs=96 kHz          |       |      | 10     | ns    |
| DIGITAL IN fs=79.38–101.76 kHz |   |                               | 20    | ns   |        |       |
| Internal Clock                 | Frequency                                 | word clock : int 44.1 kHz     |       | 44.1 |        | kHz   |
|                                |   | word clock : int 48 kHz       |       | 48   |        | kHz   |
|                                |   | word clock : int 88.2 kHz     |       | 88.2 |        | kHz   |
|                                |   | word clock : int 96 kHz       |       | 96   |        | kHz   |
|                                | Accuracy                                  | word clock : int 44.1 kHz     |       |      | 50     | ppm   |
|                                |   | word clock : int 48 kHz       |       |      | 50     | ppm   |
|                                |   | word clock : int 88.2 kHz     |       |      | 50     | ppm   |
|                                |   | word clock : int 96 kHz       |       |      | 50     | ppm   |
|                                | Jitter                                    | word clock : int 44.1 kHz     |       |      | 5      | ns    |
|                                |   | word clock : int 48 kHz       |       |      | 5      | ns    |
|                                |   | word clock : int 88.2 kHz     |       |      | 5      | ns    |
|                                |   | word clock : int 96 kHz       |       |      | 5      | ns    |
| Signal Delay                   | analog input to digital output @fs=48 kHz |                               |       | 0.9  |        | ms    |
|                                | @fs=96 kHz                                |                               |       | 0.45 |        | ms    |

## Error Messages

The AD8HR automatically diagnoses itself at the time of power up. If it detects a system abnormality, one of the following error messages appears. If an abnormality is detected, consult your Yamaha dealer.

- E1:** The backup battery voltage is low. If the voltage is lowered further, the stored data will be erased. Ask your dealer to replace the battery.
- E2:** The backup memory is corrupted.
- E3:** The backup battery voltage is very low and the backup memory is corrupted.

## DIGITAL OUT A/B Pin Assignment Table

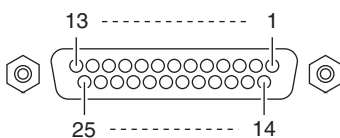

| Signal   | Data In Ch <sup>*1</sup> |     | Data Out Ch |     |     |                            | Open                       | GND |
|----------|--------------------------|-----|-------------|-----|-----|----------------------------|----------------------------|-----|
|          | 1–2                      | 1–2 | 3–4         | 5–6 | 7–8 |                            |                            |     |
| Pin Hot  | 1                        | 5   | 6           | 7   | 8   | 2, 3, 4, 9, 11, 15, 16, 17 | 10, 12, 13, 22, 23, 24, 25 |     |
| Pin Cold | 14                       | 18  | 19          | 20  | 21  |                            |                            |     |

\*1. Data In Ch can be received only on DIGITAL OUT A.

## HA REMOTE Pin Assignment Table

| Pin | Signal Name           | Pin | Signal Name           |
|-----|-----------------------|-----|-----------------------|
| 1   | N.C.                  | 6   | RX+/DSR <sup>*1</sup> |
| 2   | RX-/RXD <sup>*1</sup> | 7   | RTS                   |
| 3   | TX-/TXD <sup>*1</sup> | 8   | CTS                   |
| 4   | TX+/DTR <sup>*1</sup> | 9   | N.C.                  |
| 5   | GND                   |     |                       |

\*1. RS422/PC

## Dimensions

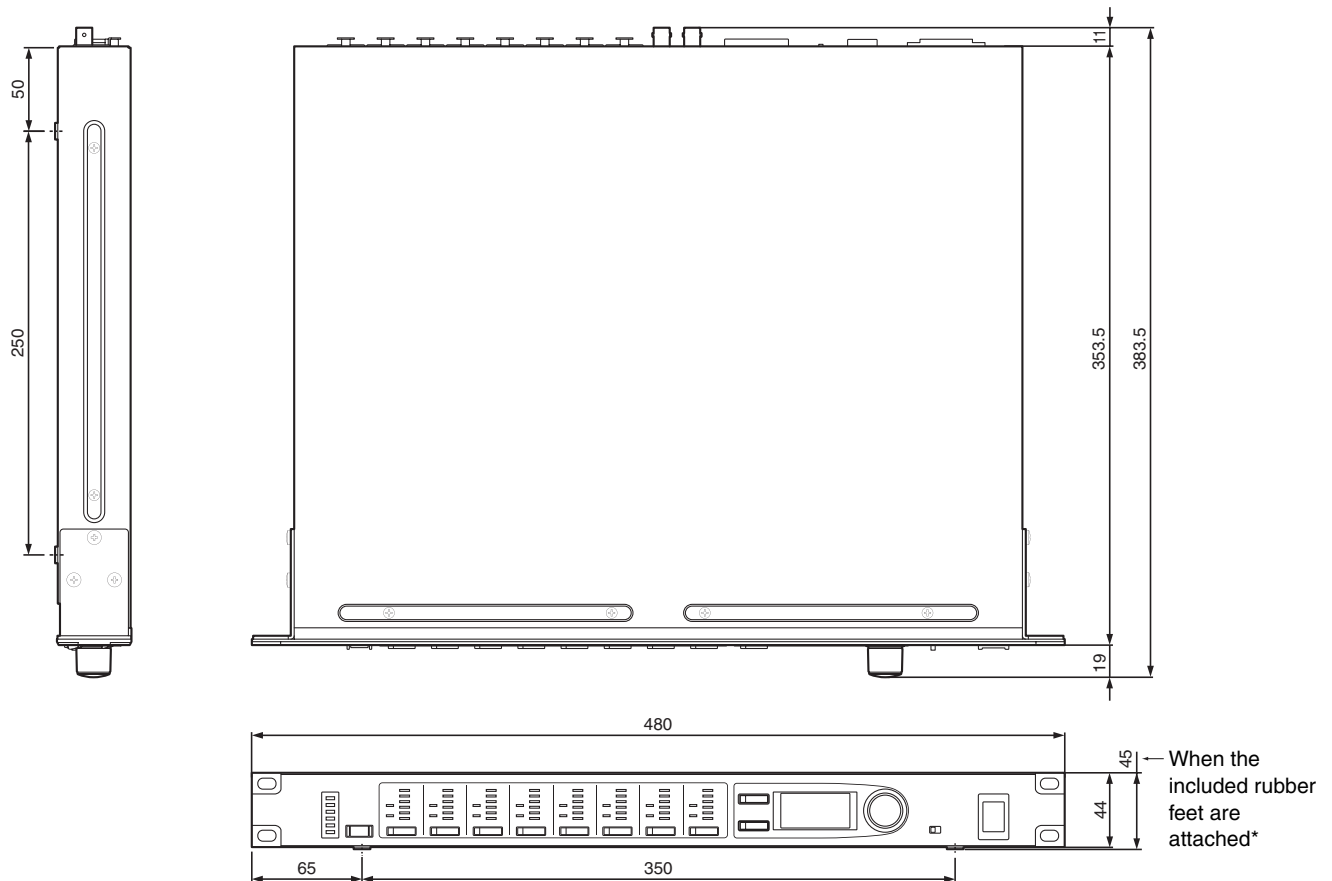

Unit mm

\* If you do not intend to rack mount the AD8HR, attach the included rubber feet to the bottom surface of the unit.

Attach the rubber feet in the positions marked by small circles on the bottom.

Specifications and descriptions in this owner's manual are for information purposes only. Yamaha Corp. reserves the right to change or modify products or specifications at any time without prior notice. Since specifications, equipment or options may not be the same in every locale, please check with your Yamaha dealer.

European models

Purchaser/User Information specified in EN55103-1 and EN55103-2.

Inrush Current: 35 A

Conforms to Environments: E1, E2, E3 and E4



For details of products, please contact your nearest Yamaha representative or the authorized distributor listed below.

Pour plus de détails sur les produits, veuillez-vous adresser à Yamaha ou au distributeur le plus proche de vous figurant dans la liste suivante.

Die Einzelheiten zu Produkten sind bei Ihrer unten aufgeführten Niederlassung und bei Yamaha Vertragshändlern in den jeweiligen Bestimmungsländern erhältlich.

Para detalles sobre productos, contacte su tienda Yamaha más cercana o el distribuidor autorizado que se lista debajo.

## NORTH AMERICA

### CANADA

**Yamaha Canada Music Ltd.**  
135 Milner Avenue, Scarborough, Ontario,  
M1S 3R1, Canada  
Tel: 416-298-1311

### U.S.A.

**Yamaha Corporation of America**  
6600 Orangethorpe Ave., Buena Park, Calif. 90620,  
U.S.A.  
Tel: 714-522-9011

## CENTRAL & SOUTH AMERICA

### MEXICO

**Yamaha de México S.A. de C.V.**  
Calz. Javier Rojo Gómez #1149,  
Col. Guadalupe del Moral  
C.P. 09300, México, D.F., México  
Tel: 55-5804-0600

### BRAZIL

**Yamaha Musical do Brasil Ltda.**  
Av. Rebouças 2636-Pinheiros CEP: 05402-400  
Sao Paulo-SP. Brasil  
Tel: 011-3085-1377

### ARGENTINA

**Yamaha Music Latin America, S.A.**  
**Sucursal de Argentina**  
Viamonte 1145 Piso2-B 1053,  
Buenos Aires, Argentina  
Tel: 1-4371-7021

### PANAMA AND OTHER LATIN AMERICAN COUNTRIES/ CARIBBEAN COUNTRIES

**Yamaha Music Latin America, S.A.**  
Torre Banco General, Piso 7, Urbanización Marbella,  
Calle 47 y Aquilino de la Guardia,  
Ciudad de Panamá, Panamá  
Tel: +507-269-5311

## EUROPE

### THE UNITED KINGDOM

**Yamaha-Kemble Music (U.K.) Ltd.**  
Sherbourne Drive, Tilbrook, Milton Keynes,  
MK7 8BL, England  
Tel: 01908-366700

### GERMANY

**Yamaha Music Central Europe GmbH**  
Siemensstraße 22-34, 25462 Rellingen, Germany  
Tel: 04101-3030

### SWITZERLAND/LIECHTENSTEIN

**Yamaha Music Central Europe GmbH,**  
**Branch Switzerland**  
Seefeldstrasse 94, 8008 Zürich, Switzerland  
Tel: 01-383 3990

### AUSTRIA

**Yamaha Music Central Europe GmbH,**  
**Branch Austria**  
Schleiergasse 20, A-1100 Wien, Austria  
Tel: 01-60203900

### CZECH REPUBLIC/SLOVAKIA/ HUNGARY/SLOVENIA

**Yamaha Music Central Europe GmbH,**  
**Branch Austria, CEE Department**  
Schleiergasse 20, A-1100 Wien, Austria  
Tel: 01-602039025

### POLAND

**Yamaha Music Central Europe GmbH**  
**Sp.z o.o. Oddzial w Polsce**  
ul. 17 Stycznia 56, PL-02-146 Warszawa, Poland  
Tel: 022-868-07-57

### THE NETHERLANDS/ BELGIUM/LUXEMBOURG

**Yamaha Music Central Europe GmbH,**  
**Branch Benelux**  
Clarissenhof 5-b, 4133 AB Vianen, The Netherlands  
Tel: 0347-358 040

### FRANCE

**Yamaha Musique France**  
BP 70-77312 Marne-la-Vallée Cedex 2, France  
Tel: 01-64-61-4000

### ITALY

**Yamaha Musica Italia S.P.A.**  
**Combo Division**  
Viale Italia 88, 20020 Lainate (Milano), Italy  
Tel: 02-935-771

### SPAIN/PORTUGAL

**Yamaha-Hazen Música, S.A.**  
Ctra. de la Coruna km. 17, 200, 28230  
Las Rozas (Madrid), Spain  
Tel: 91-639-8888

### SWEDEN

**Yamaha Scandinavia AB**  
J. A. Wettergrens Gata 1  
Box 30053  
S-400 43 Göteborg, Sweden  
Tel: 031 89 34 00

### DENMARK

**YS Copenhagen Liaison Office**  
Generatorvej 6A  
DK-2730 Herlev, Denmark  
Tel: 44 92 49 00

### NORWAY

**Norsk filial av Yamaha Scandinavia AB**  
Grini Næringspark 1  
N-1345 Østerås, Norway  
Tel: 67 16 77 70

### OTHER EUROPEAN COUNTRIES

**Yamaha Music Central Europe GmbH**  
Siemensstraße 22-34, 25462 Rellingen, Germany  
Tel: +49-4101-3030

## AFRICA

**Yamaha Corporation,**  
**Asia-Pacific Music Marketing Group**  
Nakazawa-cho 10-1, Hamamatsu, Japan 430-8650  
Tel: +81-53-460-2313

## MIDDLE EAST

### TURKEY/CYPRUS

**Yamaha Music Central Europe GmbH**  
Siemensstraße 22-34, 25462 Rellingen, Germany  
Tel: 04101-3030

### OTHER COUNTRIES

**Yamaha Music Gulf FZE**  
LB21-128 Jebel Ali Freezone  
P.O.Box 17328, Dubai, U.A.E.  
Tel: +971-4-881-5868

## ASIA

### THE PEOPLE'S REPUBLIC OF CHINA

**Yamaha Music & Electronics (China) Co.,Ltd.**  
25/F., United Plaza, 1468 Nanjing Road (West),  
Jingan, Shanghai, China  
Tel: 021-6247-2211

### INDONESIA

**PT. Yamaha Music Indonesia (Distributor)**  
**PT. Nusantara**  
Gedung Yamaha Music Center, Jalan Jend. Gatot  
Subroto Kav. 4, Jakarta 12930, Indonesia  
Tel: 21-520-2577

### KOREA

**Yamaha Music Korea Ltd.**  
Tong-Yang Securities Bldg. 16F 23-8 Yoido-dong,  
Youngdungpo-ku, Seoul, Korea  
Tel: 02-3770-0660

### MALAYSIA

**Yamaha Music Malaysia, Sdn., Bhd.**  
Lot 8, Jalan Perbandaran, 47301 Kelana Jaya,  
Petaling Jaya, Selangor, Malaysia  
Tel: 3-78030900

### SINGAPORE

**Yamaha Music Asia Pte., Ltd.**  
#03-11 A-Z Building  
140 Paya Lebar Road, Singapore 409015  
Tel: 747-4374

### TAIWAN

**Yamaha KHS Music Co., Ltd.**  
3F, #6, Sec.2, Nan Jing E. Rd. Taipei.  
Taiwan 104, R.O.C.  
Tel: 02-2511-8688

### THAILAND

**Siam Music Yamaha Co., Ltd.**  
891/1 Siam Motors Building, 15-16 floor  
Rama 1 road, Wangmai, Pathumwan  
Bangkok 10330, Thailand  
Tel: 02-215-2626

### OTHER ASIAN COUNTRIES

**Yamaha Corporation,**  
**Asia-Pacific Music Marketing Group**  
Nakazawa-cho 10-1, Hamamatsu, Japan 430-8650  
Tel: +81-53-460-2317

## OCEANIA

### AUSTRALIA

**Yamaha Music Australia Pty. Ltd.**  
Level 1, 99 Queensbridge Street, Southbank,  
Victoria 3006, Australia  
Tel: 3-9693-5111

### COUNTRIES AND TRUST TERRITORIES IN PACIFIC OCEAN

**Yamaha Corporation,**  
**Asia-Pacific Music Marketing Group**  
Nakazawa-cho 10-1, Hamamatsu, Japan 430-8650  
Tel: +81-53-460-2313

**HEAD OFFICE** Yamaha Corporation, Pro Audio & Digital Musical Instrument Division  
Nakazawa-cho 10-1, Hamamatsu, Japan 430-8650  
Tel: +81-53-460-2441

PA13

Yamaha Manual Library  
<http://www.yamaha.co.jp/manual/>

This document is printed on recycled chlorine free (ECF) paper with soy ink.

U.R.G., Pro Audio & Digital Musical Instrument Division, Yamaha Corporation  
© 2004 Yamaha Corporation  
WC24060 6081PAPx.x-0xCO  
Printed in Japan

## Free Manuals Download Website

<http://myh66.com>

<http://usermanuals.us>

<http://www.somanuals.com>

<http://www.4manuals.cc>

<http://www.manual-lib.com>

<http://www.404manual.com>

<http://www.luxmanual.com>

<http://aubethermostatmanual.com>

Golf course search by state

<http://golfingnear.com>

Email search by domain

<http://emailbydomain.com>

Auto manuals search

<http://auto.somanuals.com>

TV manuals search

<http://tv.somanuals.com>