

**PEDOMETER WITH PANIC ALARM**  
**MODEL : PE319**  
**INSTRUCTION MANUAL**

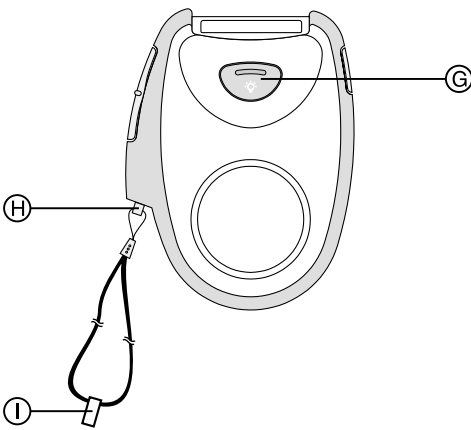

**FIG. A**

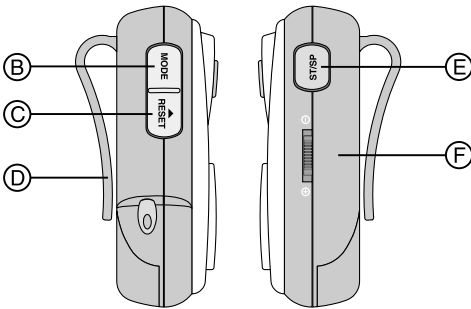
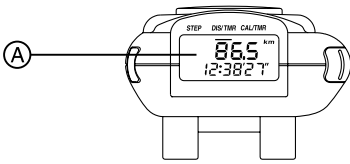
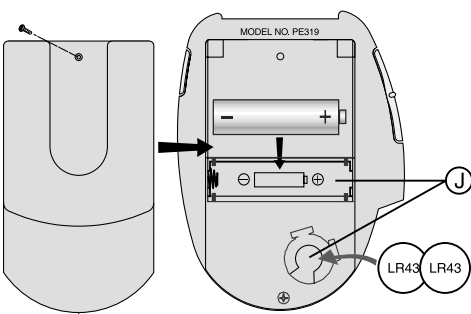

**FIG. B**

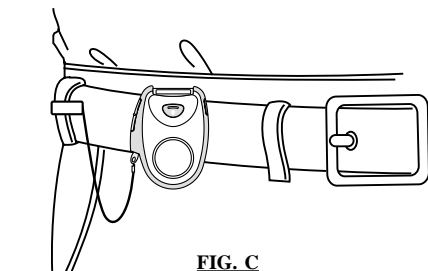

**FIG. C**

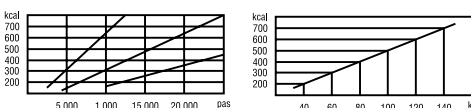

**FIG. D**

**INTRODUCTION**

Congratulations on your purchasing the Pedometer, a handy, multifunctional device that complements your active life by letting you count the steps taken in a walk or run, distance covered, calories burnt and time elapsed. What is more, the pedometer is equipped with a built-in 120-decibel panic alarm, which helps you summon attention loud and quick in time of need.

**BUILT-IN FEATURES**

1. Step counter
2. 12/24-hour format real-time clock
3. Total distance counter
4. Total calorie counter
5. Stride distance adjustment
6. Count-up timer
7. Panic alarm
8. EL backlight
9. Low-battery indicator
10. Motion sensitivity adjustment

**CONTROL BUTTONS AND PHYSICAL FEATURES [FIG. A]**

- A. LCD**  
Two-line display for easy dissemination of data
- B. [MODE] button**  
Changes display modes
- C. [RESET/▲] button**  
Resets a value to zero in normal mode or increases a value in setting mode
- D. BELT CLIP**  
For attaching to a belt or clothing
- E. [ST/SP] (START/STOP) button**  
Starts or stops the count-up timer
- F. SENSITIVITY SWITCH**  
Adjusts the sensitivity of the unit to motion
- G. BACKLIGHT [☀] button**  
Turns on the backlight
- H. PANIC ALARM PIN**  
Activates the panic alarm when detached from the unit
- I. FASTENING CLIP AND CHORD**  
For further securing the unit to clothing and acts as a pull chord for the panic alarm
- J. BATTERY COMPARTMENT**  
Accommodates 2 x LR43 size & 1 x 12V alkaline batteries

**BATTERY INSTALLATION**

Two types of battery are required. Pedometer function is powered by 2 pcs LR43 battery. Panic alarm is powered by one 12V alkaline battery.

1. Open the battery compartment door.
2. Insert two LR43 size + one 12V alkaline batteries. [FIG. B]
3. Replace the compartment door.

The low-battery indicator will light up when LR43 batteries are drying up. Replace batteries accordingly.



**Note:** If not disposed of properly, batteries can be harmful. Protect the environment by taking exhausted batteries to authorized disposal stations.

**HOW TO ATTACH THE PEDOMETER**

Use the belt clip and fastening clip to secure the pedometer horizontally to your belt, slacks or training attire. [FIG. C]

**Note:** That improper positioning of the pedometer may result in incorrect measurements.

**DISPLAY MODES**

The pedometer has three display modes: step, distance/timer, and calories/timer. To select a display mode, press [MODE]. An indicator will light up for the active mode in display.

**HOW TO USE THE BACKLIGHT**

The backlight facilitates display reading in dim lights. To use it, press the backlight button to light up the display for five seconds.

**HOW TO SET THE REAL-TIME CLOCK**

1. Press [MODE] for step display.
2. Hold [MODE] for two seconds. The 12-hour value will blink.
3. Use [▲] to select between 12-hour and 24-hour clock format.
4. Press [MODE]. The hour digits will blink.
5. Use [▲] to enter the desired value. Hold down the button for fast advancement.
6. Press [MODE]. The minute digits will blink.
7. Use [▲] to enter the desired value.
8. Press [MODE]. The second digits will blink.

9. Use [▲] to reset the digits to zeros or wait for the desired value to appear.
10. Press [MODE] to confirm and exit.

**STRIDE DISTANCE AND BODY WEIGHT**

The stride distance is used to measure the total distance covered in a run or walk. Depending on the person, you can set the stride distance between 30 to 150cm (11 to 60 inches for imperial version). To check your own stride distance, walk 10 steps and divide by 10 the total distance covered. [FIG. C]

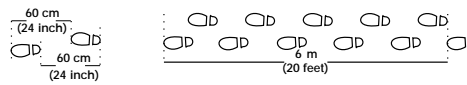

The body weight is used to calculate the calories burnt. You can set it between 30 to 150kg (60 to 340 pounds for imperial version).

**To enter the stride distance and body weight,**

1. Press [MODE] for distance/timer or calories/timer display.
2. Hold [MODE] for two seconds. The weight and stride distance will be displayed with the stride distance blinking.
3. Use [▲] to enter the desired value for stride.
4. Press [MODE]. The weight value will blink.
5. Use [▲] to enter the desired value.
6. Press [MODE] to confirm and exit.

**Note:** the pedometer will automatically return to the distance/timer display if no setting is made for seven seconds.

**STEPS, DISTANCE AND CALORIES**

To check the total number of steps taken, distance covered or calories burnt, press [MODE] for their respective displays.

To check the values over a certain distance or time,

1. Press [MODE] for step display.
2. Press [RESET] to clear the value. Note the total distance and calories will be cleared alongside with the total steps.
3. Press [MODE] for distance/timer or calories/timer display.
4. Press [RESET] to clear the timer.
5. Press [ST/SP] to start the timer when ready. The timer will count up to 99 hours, 59 minutes and 59 seconds before restarting from zeros again.
6. Go! The pedometer will start registering the data if any motion is detected afterwards.
7. Press [ST/SP] to stop the timer when done.

**Note on motion sensitivity:** To make the unit more or less sensitive to motion, reposition the motion sensitivity slide switch. To determine the proper amount of motion sensitivity for an individual walking pattern, experiment with different settings.

**FITNESS TIPS**

To keep fit, it generally takes a person weighing 60kg to walk 10,000 steps to burn approximately 300 calories. The following diagram will give you some basic reference to the calorie consumption for people of various weights. [FIG. D]

**HOW TO USE THE PANIC ALARM**

The alarm will be activated when the panic alarm pin is detached from its socket. Pull the chord and detach the pin when the situation arises.

To stop the alarm, simply reconnect the pin to its socket.

**Note :** One new 12V battery can last for approx. 15 minutes if the panic alarm activate. It is suggested to test the alarm function every time before you use the pedometer.

**SPECIFICATIONS**

Operating Modes	: STEP, DIST/TIMER, CAL/TIMER
Real time clock	: 12/24 hour option with hour : minute : second display
Step counter	: 0 to 99,999 steps
Distance traveled	: 0 to 999.99km (or 0 to 999.99 miles for imperial version)
Calorie consumption	: 0 to 99999 kcal.
Count up timer	: 99 hours, 59 minutes, 59 seconds
Stride distance	: 30 to 150 cm (or 11 to 60 inches for imperial version)
Weight range	: 30 to 150 kg (or 60 to 340 lbs. for imperial version)
Panic alarm	: around 110-115 dB measured at 5 cm distance
Power source	: 2 x LR43 1.5V battery + 1 x 12V alkaline
Operation temperature	: -10°C to 40°C
Storage temperature	: -20°C to 60°C
Product size	: 52 x 70 x 23 mm (W x H x T)
Weight	: 54g (battery included)

**MAINTENANCE**

1. Do not immerse the unit in water. If the unit comes in contact with water, dry it immediately with a soft lint-free cloth.
2. Do not clean the unit with abrasive or corrosive materials. Abrasive cleaning agents may scratch the plastic parts and corrode the electronic circuit.
3. Do not subject the unit to excessive: force, shock, dust, temperature, or humidity. Such treatment may result in malfunction, a shorter electronic life span, damaged batteries, or distorted parts.
4. Do not tamper with the unit's internal components. Doing so will terminate the unit's warranty and may cause damage. The unit contains no user-serviceable parts.
5. Only use new batteries as specified in this instruction manual. Do not mix new and old batteries as the old batteries may leak.

**Read this instruction manual thoroughly before operating the unit.**

**CAUTION**

- The content of this manual is subject to change without further notice.
- Due to printing limitation, the displays shown in this manual may differ from the actual display.
- The manufacturer and its suppliers held no responsibility to you or any other person for any damage expenses, lost profits, or any other claim arise by using this product.
- The contents of this manual may not be reproduced without the permission of the manufacturer.

**WARRANTY**

Oregon Scientific products are warranted to free of defects in manufacturing for 90 days after purchase. This warranty does not cover a product subjected to abuse, misuse or accidental damage.

If you have any questions about this product, please call Oregon Scientific at (800) 853-8883 or e-mail us at [helpme@oscientific.com](mailto:helpme@oscientific.com). Defective returns should be directed to the place of retail purchase.

## Free Manuals Download Website

<http://myh66.com>

<http://usermanuals.us>

<http://www.somanuals.com>

<http://www.4manuals.cc>

<http://www.manual-lib.com>

<http://www.404manual.com>

<http://www.luxmanual.com>

<http://aubethermostatmanual.com>

Golf course search by state

<http://golfingnear.com>

Email search by domain

<http://emailbydomain.com>

Auto manuals search

<http://auto.somanuals.com>

TV manuals search

<http://tv.somanuals.com>