

Nikon

MICROSCOPE MODEL L-Ke

INSTRUCTIONS

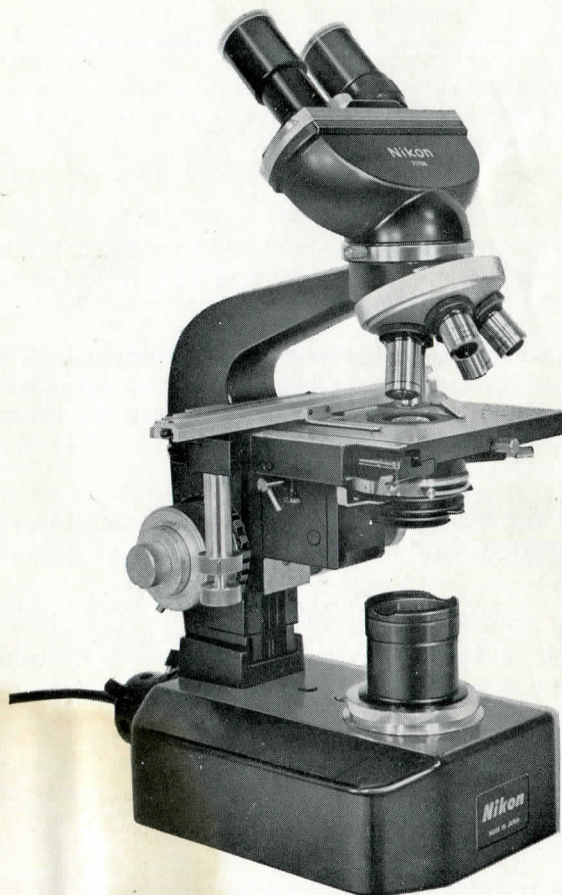

Copy offered by courtesy of Dr. Steven Horii, USA

Download from www.Ser Manuals.com All Manuals Search And Download.

NIPPON KOGAKU K.K.

Caution in Handling and Maintenance

- Avoid touching lens surfaces with the fingers or with any rough material. For dusting, use a feather or a soft lens brush and then a washed-out soft cotton cloth only to wipe off finger marks or grease, wet the cloth with xylor, but never with alcohol or ether. The microscope body surfaces should be dusted in the same way and may slightly be oiled.
- Tightness of the coarse focusing knobs should be adjusted, in this type (L-Ke) of microscope, by means of the adjusting ring, not by twisting the knobs.
- Dismantling of the internal optical parts and the microscope body should not be attempted, because it may interfere with the performance of the instrument. It can be accomplished only by an expert or the original manufacturer.
- Do not apply any grease of not specified type to the sliding surfaces of the coarse focusing adjustment and of the floating stage. If necessary, ask for your dealer or the manufacturer.
- The microscope is to be used at a dust-free place. Avoid any forcible manipulation of the moving parts. At all times the instrument is to be handled carefully e.g. for carrying the microscope, hold its base with one hand and its arm with the other.
- When not in use, it should be covered with the vinyl cover or kept in the wooden cabinet which is available on order. Store it at a dry place. It is recommended to keep the objectives and eyepieces in a desiccator.

CONTENTS

NOMENCLATURE	3
VARIOUS COMBINATIONS	5
1. Interchangeable Eyepiece Tubes	6
"U" Trinocular	6
"T" Trinocular	6
"B" Binocular	6
"I" Inclined Monocular	6
2. Interchangeable Stages	6
"R" Rectangular Mechanical	6
"G" Graduated, Circular Rotatable	6
"C" Circular Floating	6
"P" Square Plain	6
OBJECTIVES, EYEPIECES, CONDENSERS	7
1. Objectives	7
2. Eyepieces	7
3. Combinations of Objectives and Eyepieces	8
4. Condensers	9
ATTACHING THE LENSES	10
1. Mounting the Objectives	10
2. Mounting the Eyepieces	11
3. Mounting the Condenser	11
ILLUMINATION	12
1. Condenser Iris Diaphragm and Images	12
2. Light Source	13
3. Condenser Focusing Knob	13
4. Brightness Adjustment	14
5. Preparation and Adjustment	14
6. Observation	15
7. Photomicrography	15
8. Other Light Sources	15
9. Filter Case	15
FOCUSING	16
1. Focusing Adjustment	16
2. Eyepiece Adjustment	16
3. Coarse Focusing	17
4. Preset Device	17
5. Fine Focusing	18
6. Oil Immersion	18
7. Long Working Range of the Stage	19
8. Exchanging the Stage	19
MOVING THE SPECIMEN ON THE STAGE	19
1. Rectangular Mechanical Stage "R"	19
2. Circular Floating Stage "C"	20
EXCHANGING THE OBJECTIVE NOSEPIECE	21
PHOTOMICROGRAPHY	22

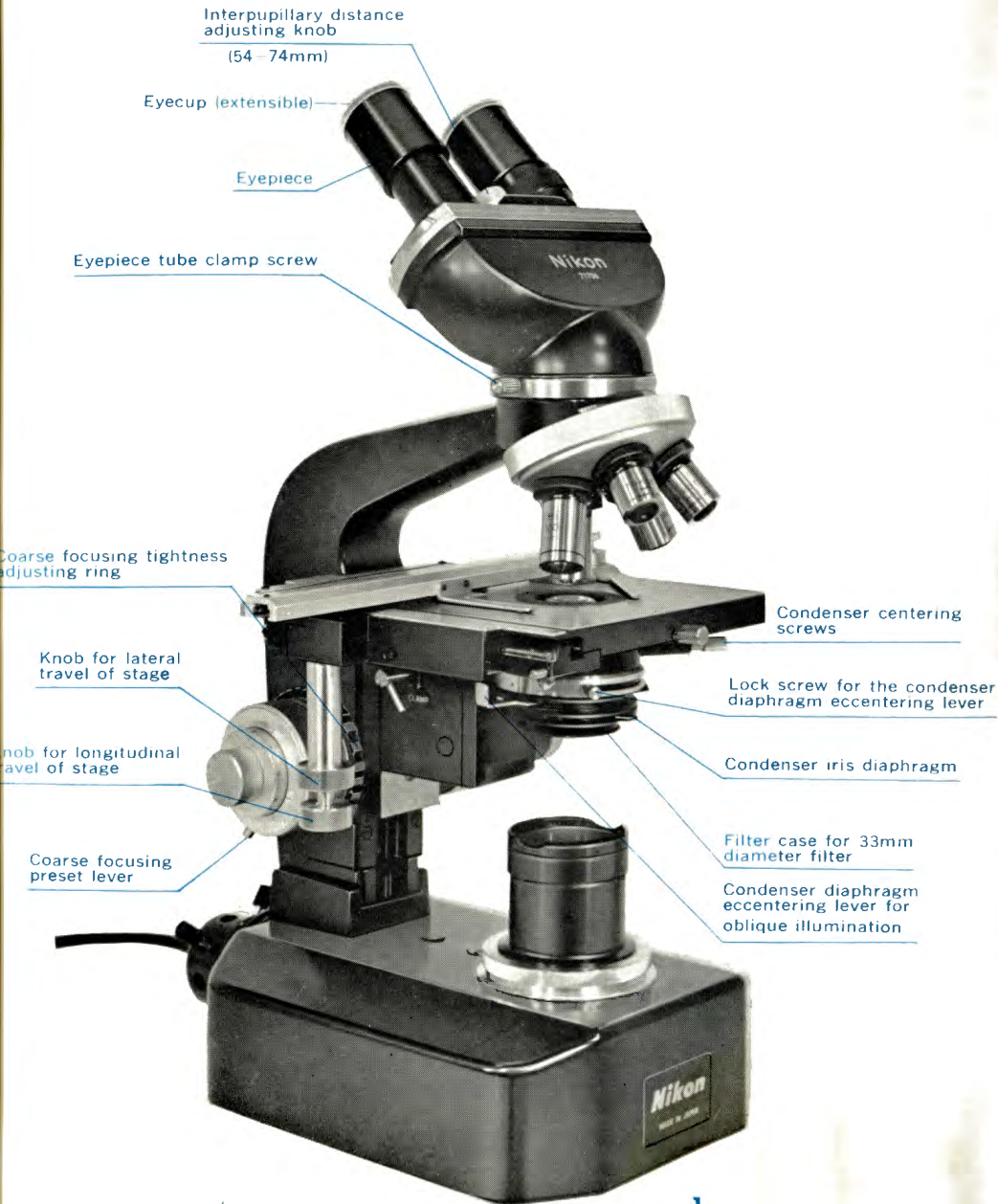

NOMENCLATURE (MODEL LBR-Ke)

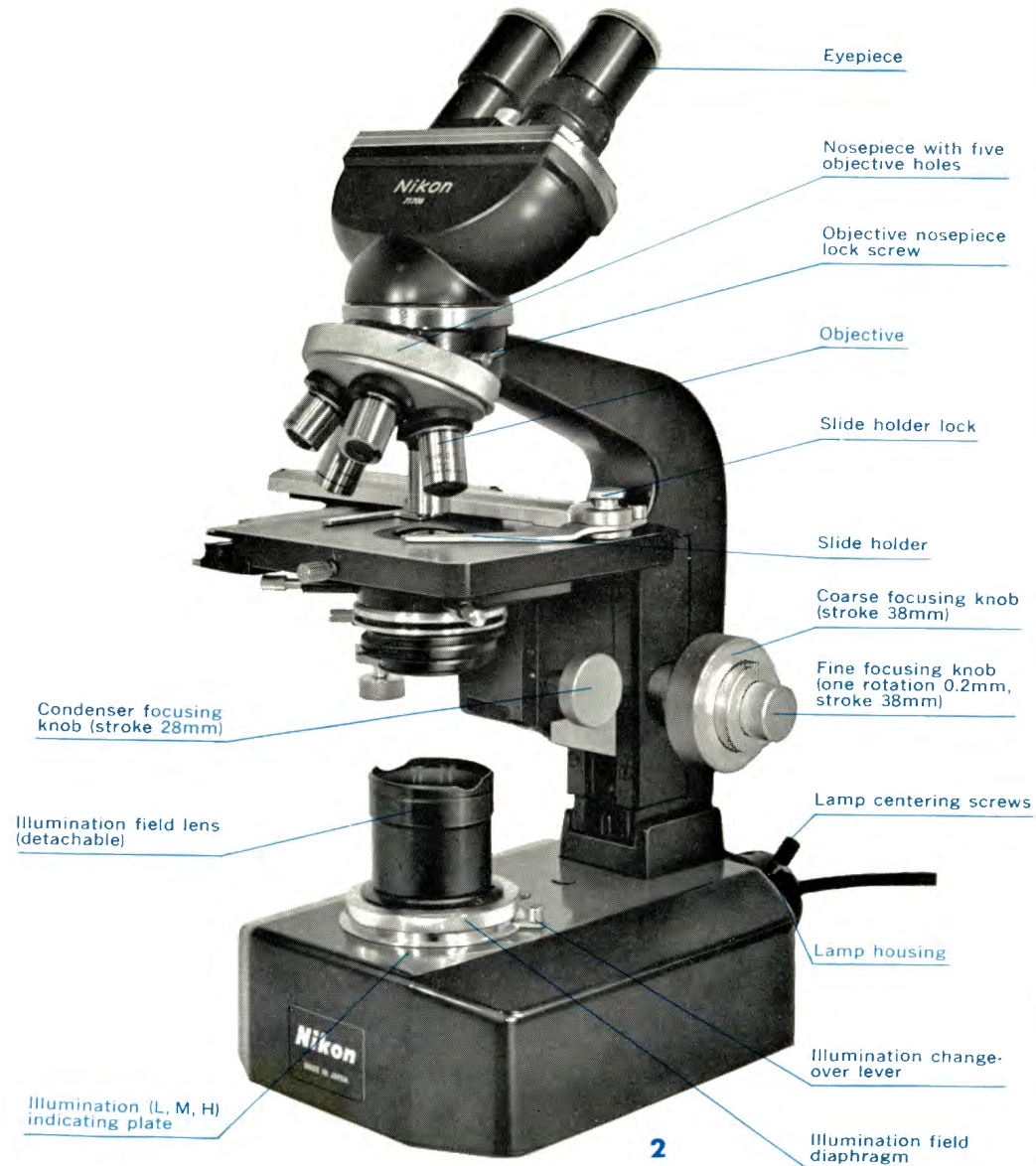

VARIOUS COMBINATIONS

The Nikon Microscope Model L-Ke is available in various combinations with objectives, eyepieces, condensers, eyepiece tubes, and stages. For example, Model LBR-Ke consists of Model L microscope stand with Koehler illuminator built-in base, Binocular eyepiece tube and Rectangular mechanical stage.

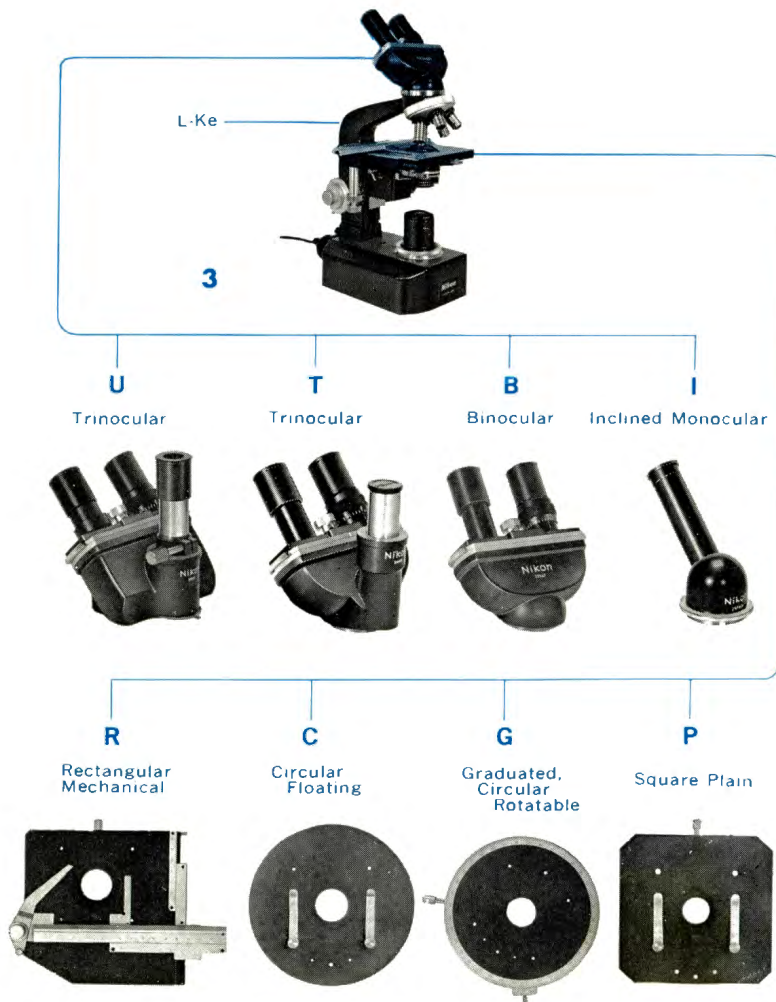

1. Interchangeable Eyepiece Tubes

U=Trinocular

Magnification factor 1X. Has provision for diopter compensation and interpupillary distance adjustment from 54mm to 74mm. Observation binoculars inclined 45°, photo-tube upright, 360° rotatable. With built-in sliding prism system, light transmission can be switched over three ways to permit photomicrography through vertical tube while viewing through binocular tube; 100% light directed to observation binoculars by switching over light path; or whole light transmission directed to vertical photo tube for photomicrography, micro-projection or closed-circuit T.V. pickup.

T=Trinocular

Magnification factor 1X. Has fixed beam-split ratio, 50% to observation binocular tubes and 50% to vertical photomicrographic tube. Inclined 45° and rotatable 360°. Has provision for diopter compensation. Interpupillary distance adjustment from 54mm to 74mm.

B=Binocular

Magnification factor 1X. Inclined 45° and rotatable 360°. Has provision for diopter compensation. Interpupillary distance adjustment from 54mm to 74mm.

I=Inclined Monocular

Interchangeable with other type eyepiece tubes. Inclined 45° and rotatable 360°

2. Interchangeable Stages

R=Rectangular Mechanical

Stage surface 130mm×140mm. Has low-positioned coaxial X and Y motion controls which provide exceptionally fine, smooth crosstravel within range of 50mm×75mm. Scales graduated to 0.1mm on vernier.

G=Graduated, Circular Rotatable

Stage surface 140mm in diameter. 360° rotatable. Goniometer divided into 1° increments and reads to 6' with vernier. Centerable stage provided with clamping screw. Supplied with stage clips.

C=Circular Floating

Stage surface 140mm in diameter. Provided with stage clips. Accepts attachable mechanical stage available on order. Moves smoothly in any direction within circle diameter of 18mm in straight and/or rotating motion. Can be clamped in any desired position.

P=Square Plain

Stage surface 130mm×130mm. Provided with stage clips. Accepts attachable mechanical stage available on order.

OBJECTIVES, EYEPIECES, CONDENSERS

1. Objectives

a. OBJECTIVES for medical and biological use

Type	Individual Magnification	Numerical Aperture	Focal Length	Working Distance	Remarks	
Achromatic Dry	4X	0.10	28.3mm	9.50mm	Spring-loaded No cover glass type	
	10X	0.25	14.8mm	7.10mm		
	20X	0.40	7.5mm	5.70mm		
	40X	0.65	4.3mm	0.54mm		
	S40X	0.65	4.3mm	0.54mm		
	NC40X	0.65	4.3mm	0.52mm		
	100X	1.25	1.8mm	0.16mm		
	S100X	1.25	1.8mm	0.16mm		
	100X	1.25	1.8mm	0.16mm		
	Oil-immersion					Spring-loaded With iris diaphragm for dark-field
Plan Achromatic Dry	Plan 1.2X	0.03	35.8mm	29.7mm	Spring-loaded Spring-loaded, no cover glass type Spring-loaded	
	2X	0.05	42.3mm	35.6mm		
	3X	0.08	37.7mm	28.6mm		
	4X	0.10	29.5mm	18.2mm		
	10X	0.25	15.6mm	7.0mm		
	40X	0.65	4.0mm	0.24mm		
	NC40X	0.65	4.1mm	0.32mm		
	100X	1.30	1.6mm	0.12mm		
	Oil-immersion					
	Plan Apochromatic					
Oil-immersion	100X	1.30	1.6mm	0.12mm	Spring-loaded	
Apochromatic Dry	40X	0.80	4.3mm	0.19mm	Spring-loaded	
Oil-immersion	100X	1.40	1.6mm	0.10mm	Spring-loaded	
Long-Working Distance Type Achromatic Dry	LWD40X	0.60	4.0mm	2.0mm	For tissue culture observation	
Phase-Contrast Achromatic Dry	DLL10X	0.30	15.9mm	6.4mm	Dark Contrast	
	B-M10X	0.30	15.9mm	6.4mm	Bright Contrast	
	DLL20X	0.40	8.2mm	4.5mm	Dark Contrast	
	B-M20X	0.40	8.2mm	4.5mm	Bright Contrast	
	DLL40X	0.65	4.4mm	0.54mm	Dark Contrast, Spring-loaded	
	D-M40X	0.65	4.4mm	0.54mm	Dark Contrast //	
	B-M40X	0.65	4.4mm	0.54mm	Bright Contrast //	
	DLL100X	1.25	1.8mm	0.16mm	Dark Contrast //	
	D-M100X	1.25	1.8mm	0.16mm	Dark Contrast //	
	B-M100X	1.25	1.8mm	0.16mm	Bright Contrast //	
Oil-immersion				Dark Contrast //		
Long-Working Distance Achromatic Dry	D-M40X	0.60	4.0mm	2.0mm	(For tissue culture work)	

b. OBJECTIVES for metallurgical use

Metallurgy Achromatic Dry	M5X	0.10	25.0mm	15mm	
	M10X	0.25	14.8mm	7.1mm	
	M20X	0.40	7.5mm	5.7mm	
	M40X	0.65	4.3mm	0.52mm	
	M100X	1.25	1.8mm	0.16mm	
	Plan Achromatic Dry	Plan M10X	0.25	15.6mm	
Plan M40X	0.65	4.1mm	0.32mm		
Plan M100X	1.30	1.6mm	0.12mm		

2. Eyepieces

Type	Individual Magnification	Focal Length	Field Number	Remarks
High eyepoint, compensating	HK5X	50mm	21.0	With adjustable eyepiece collar
High eyepoint, compensating, wide-field	HKW10X	25mm	18.0	With adjustable eyepiece collar
High eyepoint, compensating, wide-field	HKW15X	16.7mm	14.0	With adjustable eyepiece collar
Compensating, wide-field	WF10X	25mm	18.0	High-power purpose
Compensating	K20X	12.5mm	8.0	General purpose
Huygenian	H5X	50mm	21.0	General purpose
	H10X	25mm	12.0	General purpose
	H15X	17mm	8.0	General purpose
Diopter adjustable, high eyepoint, compensating, wide-field	DHKW10X	25mm	18.0	Supplied together with "U" eyepiece tube With 5X, 10X, 15X picture frames plus cross-lines for framing and focusing

3. Combinations of Objectives and Eyepieces

Total magnifying power obtained by the combination is the product of individual objective power multiplied by individual eyepiece power. A selection of the combination will be decided so as to get the highest resolution of the image (resolving power), the largest extent of object area (real field) which can be observed without moving the stage or slide, or the greatest thickness of object (depth of focus) which can be distinctly seen without raising or lowering the microscope stage, depending upon the purpose of using the microscope. Shown below are the results compiled from the different combinations of objectives and eyepieces:

Objective	Eyepiece	Total Magnifying Power	Working Distance (mm)	Resolution or Minimum Resolved Distance		Real Field of View (mm)	Depth of Focus (μ)	
				in object (μ)	in image (mm)			
4X	5X	20x	9.5	2.7-5.5	0.05-0.11	5.25	100	
	10X				0.11-0.22			4.5
	15X				0.16-0.32			3.5
10x	5X	50x	7.1	1.1-2.2	0.05-0.11	2.1	16	
	10X				0.11-0.22			1.8
	15X				0.17-0.33			1.4
20x	5X	100x	5.7	0.69-1.38	0.07-0.14	1.05	6	
	10X				0.14-0.28			0.9
	15X				0.21-0.42			0.7
40x	5X	200x	0.54	0.42-0.84	0.08-0.17	0.52	1.8	
	10X				0.17-0.34			0.45
	15X				0.25-0.50			0.35
100x	5X	500x	0.16	0.22-0.44	0.11-0.22	0.21	0.6	
	10X				0.22-0.44			0.18
	15X				0.33-0.66			0.14

- The working distance is the clearance between the upper surface of the cover glass and the lowest edge of the objective critically focused. Note that, as shown in the above table, the working distance becomes very small for high power objectives.
- The resolution of minimum resolved distance (the limit of resolving power) is the minimum distance between object points discernible as separate under the microscope illuminated by the light of wave length $550m\mu$. The shorter the light wave length, the higher the resolving power, that is, the small resolving distance results. In the table, the smaller values indicate the resolution obtained by oblique and the larger values by central illumination. (see "Illumination" on page 11)
- The minimum resolved distance in the image is the value in the object multiplied by the total magnification of the microscope. If the resolving power of the microscope is important, choose the eyepiece by the use of which the image resolution comes within that of the naked eye $0.15-0.3mm$ (when the object is seen from the distance 25mm); generally accepted criterion on the upper limit of the total magnification of a

microscope set up is about 500—1000X of the numerical aperture of the objective to be used. Note that in photomicrography it is useless to raise the magnification beyond the resolving power of the emulsion (usually about 0.05mm). However, since the resolution of the emulsion is higher than that of the naked eye, photographs are usually taken at a lower magnification and thereafter they are enlarged.

- **Real field of view (in mm)** represents the extent of the object that comes under observation. In higher magnification it becomes extremely small. Consequently, it is advisable to take aim at the object point to be examined first under lower magnification and then revolve the nosepiece to higher magnification.
- **When focus is on the center of the field,** its circumference will usually be blurred, because a curvature of the image plane is unavoidable in the microscope, except when using a plan type objectives. In order to get sharp corner image, it is necessary to adjust the fine focusing knob and switch the focus from the center onto the corners.
- **Depth of focus** represents the thickness or height of the object in μ sharply seen when observation is made through the microscope. In photomicrography the depth of focus becomes smaller than the figure shown in the previous table. Therefore, careful attention must be made in focusing when taking microscope pictures.
By closing the condenser diaphragm, the depth of field can be made greater than the value shown in the table.

4. Condensers

Type	Numerical Aperture	Remarks
Abbe	1.30 Two lenses	For central illumination (without oblique illumination slider)
Abbe	1.30 Two lenses	For central and oblique illumination (with oblique illumination slider)
Aplanatic	1.40 Three lenses	For high-class microscopy
Achromatic	1.25 Five lenses	For high-class microscopy
Achromatic (long focal-length type)	0.7 Four lenses	Long focal-length type. Working distance 12mm. With turret-mounted annular diaphragms for phase-contrast and phase-interference microscopy.
Universal Dark-Field Condenser	1.20-1.40 for dark-field	Supplied in centerable mount. With outer diameter 36.8 mm. Objectives to be used 10X up to 100X. Ideally suited for fluorescence work. 100X objective used should have built-in adjustable iris diaphragm. Thickness of slide glass to be used, must be less than 1.2mm.
Low-Power Condenser	Single lens	For low-power macro-objectives, e. g., 1.2X, 2X, & 3X Plan Achromatic

These condensers are not only capable of concentrating light-beam for better illumination of the image field, but also gives a great influence on the resolution of microscope image, image contrast and depth of focus. In precise observation and photomicrography, the use of an achromatic or aplanatic condenser with the maximum numerical aperture 1.25 provided with an oblique illumination device and a filter case is specially recommended.

ATTACHING THE LENSES

Before attaching the objective and the eyepiece to the microscope, first clean their outer lens surfaces. Even a slightly stained finger mark may often interfere with the image contrast.

1. Mounting the Objectives

Take special care in handling the objectives.

Before attaching the objectives on the nosepiece revolver, lower the microscope stage sufficiently. Securing each objective with the fingers

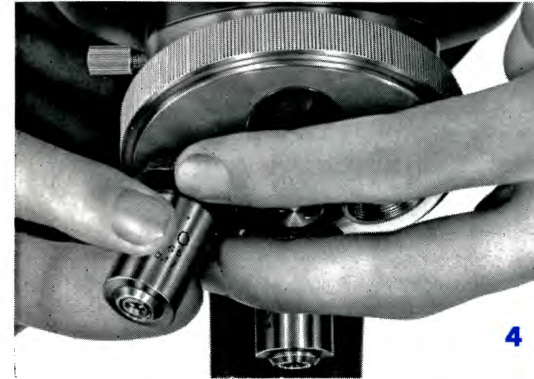

of one hand, screw into each nosepiece hole with those of the other hand (Fig. 4).

It is recommended to mount the objectives on the nosepiece orderly from low to high powers so that the magnification of each objective augments as the revolver is rotated clockwise or counter-clockwise.

Microscope Model L-Ke has on its upper surface of the nosepiece revolver five blank spots (Fig. 5) on each of which the objective magnification can be inked so that, by

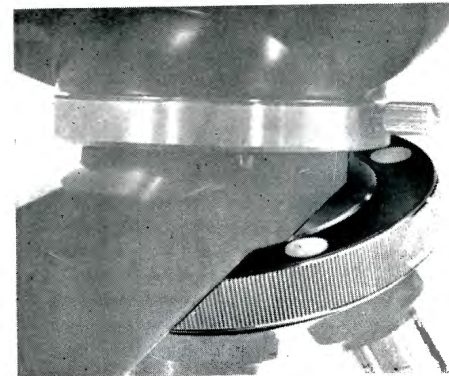

looking these indications from above, the objective located below can be identified without having to turn away your eyes from the eyepiece.

When rotating the revolver, hold its outer milled rim with your thumb and first finger, but do not push the objective barrels, otherwise alignment of the objectives may be troubled.

2. Mounting the Eyepieces

For mounting, simply drop the eyepiece into the eyepiece tube. It is recommended to leave an eyepiece in place even when it is not in use, in order to prevent the entrance of dust into the eyepiece tube. Or put on the eyepiece cap in place of the eyepiece removed. The inclined eyepiece body tube, trinocular, binocular or monocular, can be rotated after loosening the clamp screw (Fig. 6) for convenience in viewing from any desired direction without moving the



microscope stand. By further releasing the clamp screw the body tube can be removed and replaced with another type eyepiece body tube.

3. Mounting the Condenser

To mount the condenser, unlock the lock screw, and insert the condenser beneath the condenser holder as far as it will go. Then, tighten the lock screw. In this case locate the diaphragm eccentricing lever and its screw at a proper place so as to facilitate their manipulation with one hand (Fig. 7). The correct distance to retain immersion oil between the lower surface of the slide and the top of condenser is secured when the condenser is raised to the upper limit by turning the condenser focusing knob.

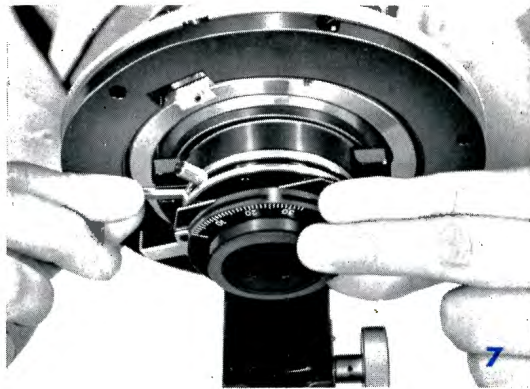

microscope stand. By further releasing the clamp screw the body tube can be removed and replaced with another type eyepiece body tube.

ILLUMINATION

Resolution and contrast of image are greatly affected by the method of illumination.

1. Condenser Iris Diaphragm and Images

Stop down the condenser iris diaphragm and slide it in the radial direction from center to edge. The farther the iris diaphragm is off-centered, the higher becomes the contrast and resolution, which distinguish details of object by increased and unsymmetrical shadow at the boundary of object (Fig. 8, a, b).

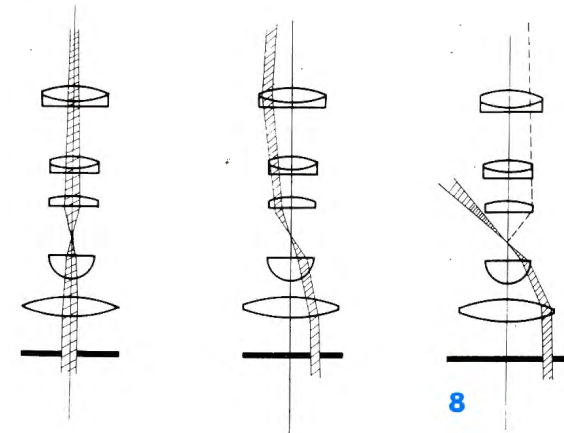

(a) Central illumination (b) Oblique illumination (c) Dark field illumination

When the iris diaphragm is positioned so as to let the light bundle enter into the object at an angle of incidence the same as the aperture angle of the objective the resolution reaches maximum and twice as much as the resolution by central illumination.

If the diaphragm is further eccentricated to such an extent as not to introduce the light bundle directly into the objective, dark field illumination will be obtained. If the iris diaphragm is widely opened, images by various angle illuminations are integrated. An illumination angle not favorable for the object may be included.

In the central illumination the maximum resolution is obtained when the opening of the iris diaphragm just corresponds to the aperture angle of the objective. In this case excessive outer rays to be used as dark field illumination are cut off and flare is minimized. If the opening is made smaller, the contrast is enhanced, though the resolution is lowered. But if the iris diaphragm is large enough to cover 60-70% of the objective aperture, the decrease of resolution will not be remarkable.

If the diaphragm is stopped down to minimum for admitting only very

small light bundles, the effects by diffraction, reflection, refraction, etc., may be exaggerated so that fringes may be seen at the image edges which may likely induce misinterpretation of the image, but it may be effective for special occasions (e.g. definition of general structure of non stained specimens). (Fig. 8, c).

2. Light Source

As already cited, the iris diaphragm plays an important role in the illumination on microscopy. As a principle the diaphragm should be so adjusted that the numerical aperture of the condenser is equal to that of the objective being used, in order to obtain the maximum resolution. In



practice, however, to keep out stray light which would reduce image contrast, closing the aperture of the condenser down to 60-70% of that of the objective lens will bring about a good result in most cases. The coincidence of condenser diaphragm aperture with the opening (exit pupil) of the objective can be ascertained by looking through the microscope tube after removing the eyepiece and closing the diaphragm slowly. An experienced user, however, may dispense with such a procedure, and will obtain the same result by adjusting the diaphragm opening until satisfactory distinctness of the image is obtained.

If a high resolution and, at the same time, a high contrast are desirable, oblique illumination will be effective. This is suited especially for lowdyed specimens, transparent phase-contrast specimens, etc. However, in this illumination, a remarkable polarity in contrast and resolution may appear; it is necessary for observation to change the direction of illumination, by turning the iris diaphragm.

The condenser aperture is off-centered in any direction by rotating and at the same time by radially sliding the diaphragm. This manipulation can be done only by using one hand, the thumb and the first finger for off-centering and the middle finger for opening or closing the diaphragm. (See Fig. 9).

3. Condenser Focusing Knob

The condenser focusing is made by turning the condenser focusing knob. This manipulation is necessary only in case of Koehler illumination or dark

field observation. The condenser is usually to stay at the upper limit and need not to be lowered, except when a stray image of an outside object superimposes the specimen image too sharply in such a case as in direct sun light illumination or as some uneven brightness interferes with the observation.

4. Brightness Adjustment

For this purpose adjust the voltage of current supply by regulating the transformer of the illuminator or by using a proper neutral density filter. Adjustment by means of the condenser diaphragm is not at all possible.

5. Preparation and Adjustment

(1) Lamp and Socket

As shown in Fig. 10, lining up the red dot on the socket retaining ring to that on the lamp housing, fit the socket to the housing by bayonet fashion.

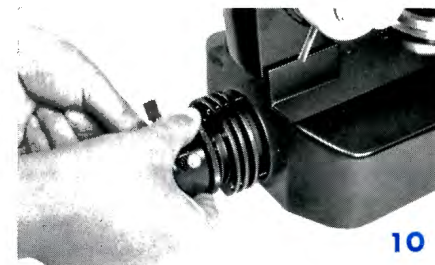

(2) Centering and Focusing of the Lamp

Bring the illumination change-over lever in the position "M". Stop down the condenser diaphragm beneath the microscope stage. Move the lamp back and forth to bring the image of the filament into sharp focus on the bottom surface of the diaphragm. For this purpose, it is convenient to utilize the reflection on the accessory reflecting mirror, as shown in Fig. 11. Then, turn right or left only the socket ring to fasten the lamp socket in position.



Bring the illumination change-over lever to the position "H". Manipulating the lamp centering screws, make centering of the image on the condenser diaphragm.

(3) Centering of the Illumination Field Diaphragm

Stop down the opening of the illumination field diaphragm to about 2mm in diameter.

Viewing through the microscope, focus the objective 40X to the image of specimen.

Moving up and down the condenser, make a sharp focused image of the illumination field diaphragm on the specimen.

Manipulate two centering screws until the image of the illumination field diaphragm comes to the center.

You need not mind about a slight deviation from this centering caused

by switching over to other objectives because this will not produce any objectionable result.

6. Observation

For usual case of observation with objectives from 4X to 100X (oil-immersion), it suffices to leave the change-over lever at the position L. When an exact illumination or extreme brightness is required, as is the case with photomicrography, it is necessary to make adjustment for each magnification by switching over the lever.

7. Photomicrography

Make exact adjustment, depending upon the magnification of the objective being used, by switching the change-over lever as below:

Objective magnification	4X	10-20X	40-100X
Position of the change-over lever	L	M	H

When using an objective 3X or lower, set the change-over lever to H and replace the condenser with the one specifically designed for lower magnification.

The illumination for the Model L-Ke will not change its color temperature by the change-over above mentioned.

8. Other Light Sources

When using any other light source outside of the microscope, replace the illumination field lens with the accessory reflecting mirror, as shown in Fig. 12.



9. Filter Case

A filter of the diameter 45mm can be mounted on the illumination field

lens. A filter of the diameter 33mm can be placed in the condenser or in the filter case of the microscope. This filter case to be attached onto the microscope base is available on order.

FOCUSING

1. Focusing Adjustment

The microscope model L-Ke is provided with coaxial, coarse and fine focusing knobs, both of which are located near the microscope base (Fig. 13). Forward rotation of either of the focusing knobs by the operator raises the microscope stage and vice versa (Fig. 13, 14).

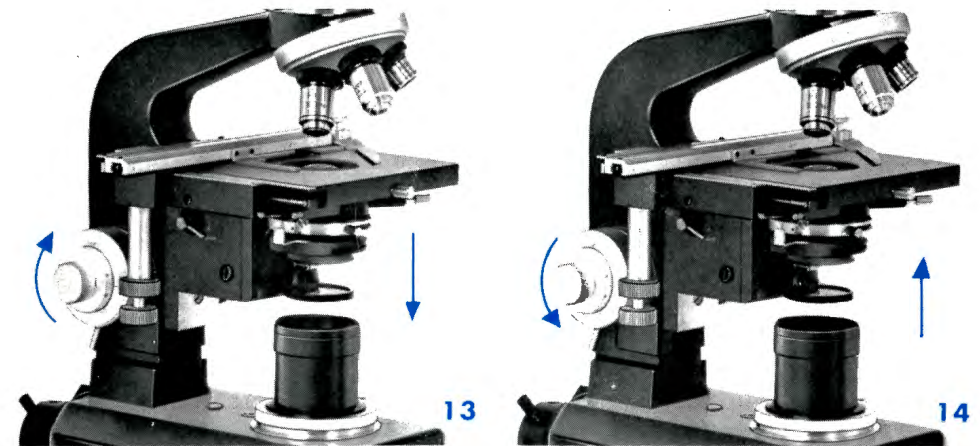

2. Eyepiece Adjustment

When using a binocular or trinocular eyepiece tube for observation the adjustment of the user's eye-sight (diopter) discrepancy between the right and left eyes is necessary which is made by rotating the adjusting ring on the lefthand eyepiece.

After focusing with your right eye by raising or lowering the microscope stage, turn the adjusting ring left or right to obtain the sharp image with your left eye, too. Then, regulate the interpupillary distance of the binocular or trinocular tube by sliding the eyepieces left or right by means of the knob (Fig. 15), until the viewfields of both eyepieces merge together. It will be advantageous to memorize the attained diopter and interpupillary distance readings for future use.

The red dot engraved on the interpupillary distance scale indicates the position where the mechanical tube length becomes exactly 160mm. The HK (high eyepoint type) eyepieces have an eyecup on top, the rotation of

which will give proper eye-to-lens distance. For those wear eyeglasses, eyecup should be screwed in.



3. Coarse Focusing

The coarse adjustment may be eased or tightened by means of the adjusting ring:

If the revolution of the coarse focusing knob is too loose, turn the adjusting ring counterclockwise. Too much tightness may be adjusted by the clockwise turning.

Never twist the focusing knobs for this adjustment as in the traditional microscope whose focusing knobs, coarse and fine, are located separate (not coaxial). Focusing may be performed as follows: First, raise the microscope stage until the distance between the specimen and the objective becomes less longer than the working distance of the objective to be used (see table on p. 8), then looking through the eyepiece, lower the stage until the specimen to be examined is plainly visible.

4X, 10X, 20X, 40X and 100X objectives are parfocal, and are approximately in focus when revolved into position one after another, the use of the fine focusing knob only being required for critical focusing.

4. Preset Device

The right-hand focusing knob has a preset lever on its drum (Fig. 16). When the lever is fastened by turning clockwise (as indicated by the arrow engraved besides) until it stops, the coarse focusing knobs cannot be turned in the direction to drive the stage closer to the objective. This presetting is

utilized for quick refocusing after the stage has been lowered and outfocused for changing the specimen or applying immersion oil. The preset device, when fastened, prevents at the same time the danger of damaging the objective front and slide glass.

5. Fine Focusing

Manipulation of the fine focusing knob is necessary:

- To obtain the sharpest image.
- To transfer the focus from center to a corner of the viewfield.
- To focus upon the different layers of a thick specimen.
- To correct a slight blurring which may take place when shifting the slide.
- To measure the thickness of object under examination.

The microscope is so designed that one revolution of the fine focusing knob raises or lowers the microscope stage 0.2mm. This permits direct reading on the right-hand knob scale up to 0.002mm (2 μ). The whole range of fine movement is 38mm; the same as of coarse focusing.

6. Oil Immersion

When using 100X objective, the application of immersion oil in the minute space (0.1mm) between the objective top and the cover glass is necessary to attain the specified numerical aperture. For critical work the immersion oil is to be filled between the top lens of the condenser and the slide as well as between the objective and the cover glass. Oil immersion observation is performed as follows: First, using 10X or 40X objective (dry system), bring the specimen in focus and in the center of the viewfield. Set the preset lever by turning clockwise. Lower the microscope stage and revolve the nosepiece revolver to 100X objective. After applying a drop of immersion oil onto the cover glass, raise the stage up to the preset limit. Then, focus up by looking through the eyepiece and raising carefully the stage by manipulating the fine focusing knob. The oil immersion 100X objective is designed to attain its critical focusing by about 1/3 forward rotation of the fine focusing knob, that is, bringing the stage about 0.08mm closer to the objective from the parfocal position. Air bubbles in the immersion oil, which may sometimes intervene the microscope image and are visible when looking into the microscope tube without the eyepiece, can be removed by repeating slight movement of the nosepiece revolver, by adding a certain quantity of immersion oil or by means of a needle.

Remaining stiffened oil may often impair the image. Therefore, im-

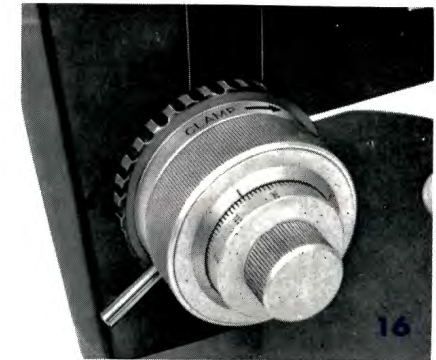

mediately after finishing the work, clean off the remaining oil from the lens using a soft cotton cloth wetted with xylor. Never use alcohol or immerse the top of the objective in xylor.

Be careful not to use immersion oil that has been thickened by age. The refractive index of the immersion oil should be 1.515.

7. Long Working Range of the Stage

The microscope L-Ke is designed to permit large-range lowering of its stage (71mm) for convenience in observing a thick specimen such as for metallurgy or culture. Unlock the lock screw beneath the stage (Fig. 17), and the stage can be lowered 33mm and by manipulation of the coarse focusing knob farther 38mm.

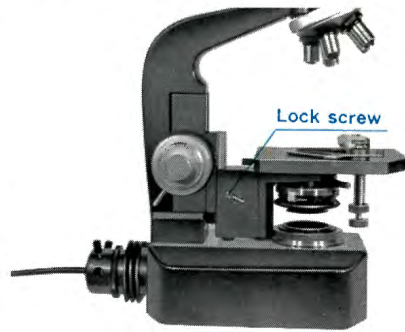

17

The stage lowered to such a great extent may be useful in macrophotography or when a special stage is used.

8. Exchanging the Stage

Lower the stage by means of the coarse focusing knob and then unlock the stage lock screw. The stage, then, can be removed.

MOVING THE SPECIMEN ON THE STAGE

1. Rectangular Mechanical Stage "R"

This stage enables fine crosswise travelling of the slide in the range of 50×75 mm, allowing reading of the movement down to 0.1 mm by the use of the vernier provided.

For securing the slide on the stage in position, open the clip.

Each travelling is performed by rotation of two coaxial knobs located one above the other on the vertical rod protruded below on the left side from the front, the upper knob being

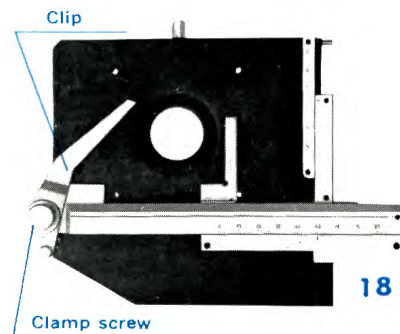

18



19

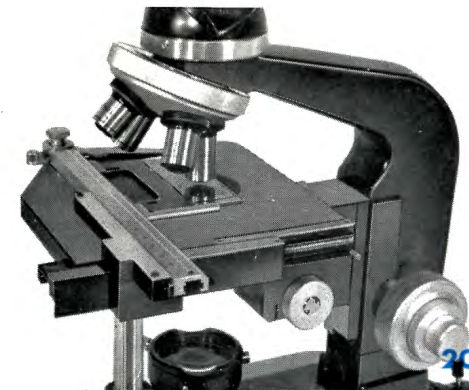

20

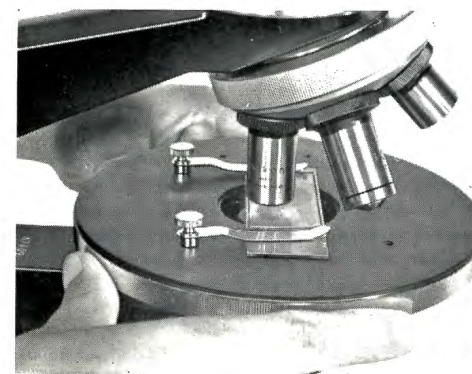

21

for longitudinal and the lower one for lateral travel of the slide on the stage.

In fluorescence microscopy or in using oil immersion objectives, where the clearance between the condenser and the slide also should be oil-immersed, stiffened oil may cause unsmooth travel of the slide. In this case, removing of the circular opening plate at the center of the stage or fastening of the clamp screw will be helpful to a positive travel of the slide (Fig. 18).

By unlocking the lock knob on the edge of the stage the stage can be rotated horizontally for convenience in the observation from the opposite side of the microscope (Fig. 19), where the eyepiece tube is to be rotated 180° . This rotation of the stage may often be of use in photomicrography, when the picture format is changed from vertical to horizontal or vice versa. It is recommended to use the slide adapter on the stage (Fig. 20) for a sufficient longitudinal travel of the slide in such reversed position.

2. Circular Floating Stage "C"

The circular floating stage (Fig. 21) glides and rotates smoothly and precisely in any desired direction simply by pushing the rim of the stage by the fingers, within a circle of 18mm in diameter.

To fasten the floating stage in position, pressing the stage

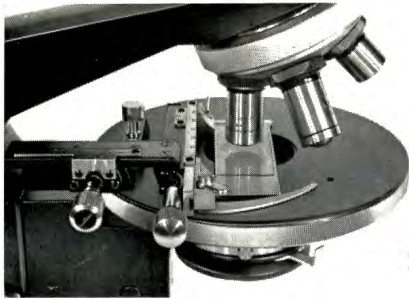

22

downward, turn the rim of the stage counterclockwise.

Fastening of the floating stage is necessary, when using an attachable mechanical stage (Fig. 22), which will be available on order.

The circular rotating stage type G is also available, which permits measurement of the rotating angle of specimen with its circular scale. (Fig. 23).

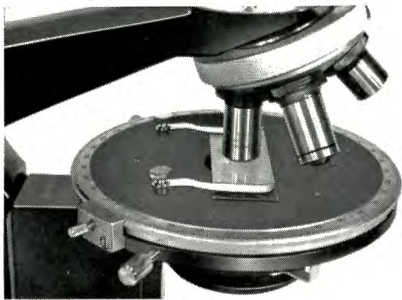

23

EXCHANGING THE OBJECTIVE NOSEPIECE

It may become necessary to exchange the objective nosepiece in such a case when a series of phase-contrast or metallurgical objectives are mounted as a unit on the other objective nosepiece.

First, unlock the revolver lock screw, and draw out the nosepiece in the direction of the arrow (Fig. 24). In place, insert the other nosepiece gently until it stops, making the guiding surfaces of the dove-tail fit parallel to each other.

Fasten the revolver in position by means of the lock screw (Fig. 25).

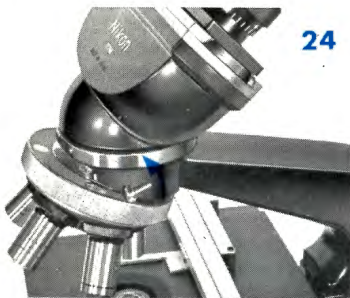

24



25

PHOTOMICROGRAPHY

The Microscope Model L-Ke, incorporating the Koehler illumination device with light source built in the microscope base, enables convenient and perfect microphotograph only by additionally mounting a camera connected to the microscope eyepiece with any photomicrographic adapter.

Therefore, when taking photographs of the microscopic image on 35mm film, it is recommended to use the Nikon Microflex Model EFM (with built-in exposure meter) or AFM (with built-in exposure meter permitting automatic exposure setting) and the Nikon F or Nikkormat camera or Nikon Dark Box for using with the above attachments. For details of photomicrographic methods, refer to the "Instructions of Using Nikon Microflex EFM" or "AFM" and any general works on photomicrography.

1. Stage vibration



NIPPON KOGAKU K.K.

Tokyo, Japan

Free Manuals Download Website

<http://myh66.com>

<http://usermanuals.us>

<http://www.somanuals.com>

<http://www.4manuals.cc>

<http://www.manual-lib.com>

<http://www.404manual.com>

<http://www.luxmanual.com>

<http://aubethermostatmanual.com>

Golf course search by state

<http://golfingnear.com>

Email search by domain

<http://emailbydomain.com>

Auto manuals search

<http://auto.somanuals.com>

TV manuals search

<http://tv.somanuals.com>