

Instruction Manual

Meade 70AZ-ADS

70mm (2.8") Altazimuth Refracting Telescope



MEADE[®]

6001 Oak Canyon, Irvine, California 92618
(800) 626-3233 ■ www.meade.com

© 2005



WARNING:

NEVER USE A MEADE TELESCOPE TO LOOK AT THE SUN! LOOKING AT OR NEAR THE SUN WILL CAUSE INSTANT AND IRREVERSIBLE DAMAGE TO YOUR EYE. EYE DAMAGE IS OFTEN PAINLESS, SO THERE IS NO WARNING TO THE OBSERVER THAT DAMAGE HAS OCCURRED UNTIL IT IS TOO LATE. DO NOT POINT THE TELESCOPE OR ITS VIEWFINDER AT OR NEAR THE SUN. DO NOT LOOK THROUGH THE TELESCOPE OR ITS VIEWFINDER AS IT IS MOVING. CHILDREN SHOULD ALWAYS HAVE ADULT SUPERVISION WHILE OBSERVING.



MEADE LIMITED WARRANTY

Every Meade telescope, spotting scope, and telescope accessory is warranted by Meade Instruments Corporation ("Meade") to be free of defects in materials and workmanship for a period of ONE YEAR from the date of original purchase in the U.S.A. Meade will repair or replace a product, or part thereof, found by Meade to be defective, provided the defective part is returned to Meade, freight-prepaid, with proof of purchase. This warranty applies to the original purchaser only and is non-transferable. Meade products purchased outside North America are not included in this warranty, but are covered under separate warranties issued by Meade international distributors.

RGA Number Required: Prior to the return of any product or part, a Return Goods Authorization (RGA) number **must** be obtained from Meade by writing, or by calling (800) 626-3233. Each returned part or product must include a written statement detailing the nature of the claimed defect, as well as the owner's name, address, and phone number.

This warranty is not valid in cases where the product has been abused or mishandled, where unauthorized repairs have been attempted or performed, or where depreciation of the product is due to normal wear-and-tear. Meade specifically disclaims special, indirect, or consequential damages or lost profit which may result from a breach of this warranty. Any implied warranties which cannot be disclaimed are hereby limited to a term of one year from the date of original retail purchase.

This warranty gives you specific rights. You may have other rights which vary from state to state.

Meade reserves the right to change product specifications or to discontinue products without notice.

This warranty supersedes all previous Meade product warranties.



TABLE OF CONTENTS

Introduction5
Standard Equipment5
Unpacking and Assembly5
8 x 21 Viewfinder Alignment6
Using the Telescope6
Some Observing Tips8
Specifications9
What Do the Specifications Mean?9
Use the Specifications to Calculate the Magnification of your Eyepiece10
Taking Care of Your Telescope10
Optional Accessories10

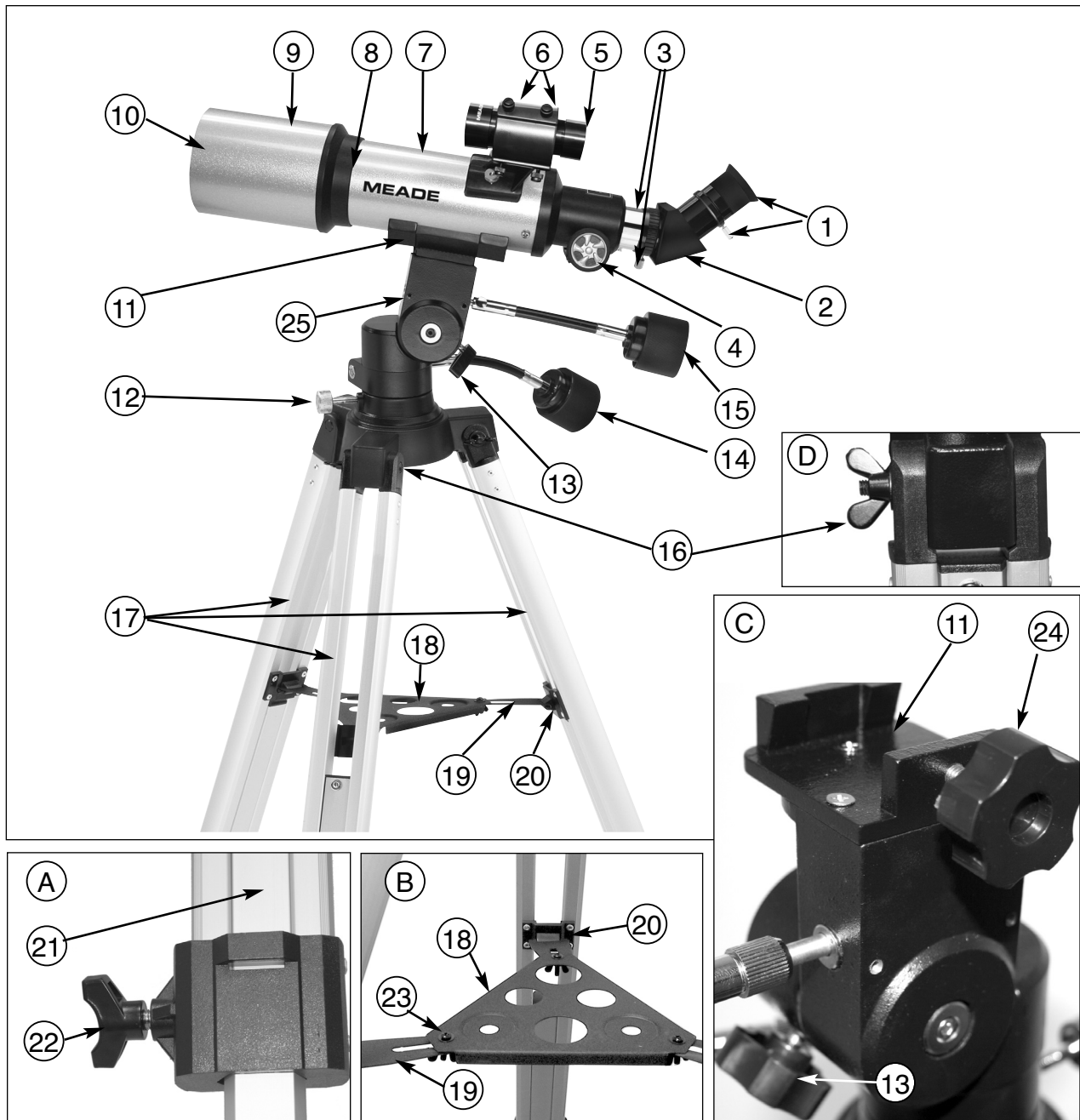

Figure 1: Meade 70AZ-ADR Altazimuth Refracting Telescope

Inset A: Tripod Leg; Inset B: Accessory Tray C: Saddle Plate Slot; D: Tripod Wingnut

- | | |
|---|--|
| 1. Eyepiece/thumbscrew | 14. Horizontal slow motion fine adjustment control cable |
| 2. 45° erect image diagonal mirror | 15. Vertical slow motion fine adjustment control cable |
| 3. Focuser drawtube and thumbscrews | 16. Wing nut and bolts (leg attachment point) |
| 4. Focusing knob | 17. Tripod legs |
| 5. Viewfinder and bracket | 18. Accessory tray |
| 6. Viewfinder collimation screws | 19. Leg brace |
| 7. Optical tube | 20. Leg brace supports |
| 8. Objective lens cell | 21. Adjustable sliding center leg extension |
| 9. Dew shield/lens shade | 22. Tripod leg lock knob (see inset A) |
| 10. Front lens cap (not visible in photo) | 23. Tray bolt and wingnut (brace-tray attachment point) |
| 11. Altazimuth mount/saddle plate slot | 24. Mounting locks knob |
| 12. Horizontal lock knob | 25. Alt/az mount |
| 13. Vertical lock knob | |

INTRODUCTION

Before you begin, we urge you to take a few minutes to completely read this manual so that you can get the best use of the equipment. This manual details the set-up, operation, specifications and optional accessories of the Meade 70AZ-ADS altazimuth refracting telescope. Designed for both astronomical and terrestrial observing, the Meade 70AZ-ADS will be your companion in exploring a universe of celestial and earthly objects.

PARTS

- Complete optical tube assembly (objective lens diameter = 70mm; focal length = 350mm)
- Full-length, fully adjustable, aluminum tripod with soft carry case and accessory tray.
- SP26mm, SP9.7mm eyepieces (1.25" O.D. "Outside Diameter")
- 45° Erect Image Diagonal mirror (1.25" O.D.), 2X barlow
- 8 x 21 viewfinder
- Altazimuth mount
- Hardware package with bolts, wingnuts, nuts, etc. necessary for assembly
- Astronomy software (separate instructions supplied in software package)

ASSEMBLY

You will need a Phillips-head screwdriver to assemble the tripod.

1. Remove and identify the telescope's components, using the listing above.
2. Attach the 3 aluminum tripod legs (**17, Fig. 1**) to the base of the altazimuth mount (**25, Fig. 1**) with the 3 leg brace supports (**20, Fig. 1**) facing inward. Line up the holes of the tripod legs with the holes on the mount base attachment (**16, Fig. 1**) and thread the three included bolts through the holes. Thread the wing nuts over the bolts and hand-tighten to a firm feel. Stand the telescope upright and spread the tripod legs evenly apart so that the accessory tray can be positioned for attachment to the leg braces.
3. To attach the leg braces to the tripod, line up the holes in the leg braces (**19, Fig. 1**) with the holes in the leg brace supports (**20, Fig. 1**) and slide the the included 1/2" screws through the holes. Thread the included nuts over the end of the bolts and hand-tighten to a firm feel. See **Inset D**.
4. To attach the accessory tray (**18, Fig. 1**) to the leg braces (**19, Fig. 1**), place the round accessory tray over the over one of the leg braces. Slide a mounting screw through the hole in one of the corners of the tray (**23, Fig. 1**), down through the slot in the leg brace. Thread a wingnut onto the bolt and tighten to a firm feel. Repeat this procedure until all three corners of the tray are mounted to the three leg braces. See **Inset B**.
5. Extend the sliding center portion of the adjustable height tripod leg (**21, Fig. 1**) to the desired length for all 3 legs. Lock the tripod legs by tightening the leg lock thumbscrew (**22, Fig. 1**) to a firm feel. See **Inset A**.
6. Position the mounting plate into the saddle plate slot (**11, Fig. 1**). Tighten the mounting lock knob (**24, Fig. 1**) to a firm feel.
7. Attach the bracket containing the viewfinder (**5, Fig. 1**) to the telescope using the 2 supplied thumbscrews. The thumbscrews thread over the 2 bolts located on the main tube.
8. Insert the diagonal mirror (**2, Fig. 1**) into the focuser drawtube (**3, Fig. 1**) and the SP 26mm eyepiece (**1, Fig. 1**) into the diagonal mirror. Tighten the respective thumbscrews to a firm feel.
9. The telescope is now completely assembled. To move the telescope and point it from one object to another, first slightly loosen the vertical lock (**13, Fig. 1**), then loosen the horizontal lock (**12, Fig. 1**). Loosening these locks allows the telescope to be moved freely (vertically or horizontally) in any direction so that the telescope can be positioned to center a terrestrial or celestial object in the telescopic field. Once an object is found, the vertical lock knob (**13, Fig. 1**) can be tightened and the vertical slow-motion fine-adjustment control knob (**15, Fig. 1**) can then be used to make very smooth and accurate tracking in the vertical axis.

8 x 21 VIEWFINDER ALIGNMENT

It is recommended that you perform steps 1 through 5 of this procedure during the daytime and step 6 at night.

1. Loosen the horizontal and vertical locks of your telescope, so that the telescope can move freely.
2. If you have not already done so, place a low-power (SP 26mm) eyepiece in the eyepiece holder or diagonal prism of your telescope. Point the telescope at an easy-to-sight land object (*e.g.*, the top of a telephone pole or sign). Turn the focuser knob to focus sharply the image in the eyepiece. Precisely center the object in the eyepiece.
3. Re-tighten the horizontal and vertical locks so that the telescope does not move during the rest of the procedure.
4. Looking through the viewfinder. Turn the viewfinder's two alignment screws (**6, Fig. 1**) until the viewfinder's crosshair point precisely at the same object centered in the eyepiece. The viewfinder is now aligned to the main telescope.
6. Check this alignment on a celestial object, such as the Moon or a bright star, and make any necessary refinements.

USING THE TELESCOPE

Observe during the daytime: Try out your telescope during the daytime at first. It is easier to learn how it operates and how to observe when it is light.

Pick out an easy object to observe: A distant mountain, a large tree, a lighthouse or skyscraper make excellent targets. Point the optical tube so it lines up with your object.

Unlock the lock knobs: To move the telescope, you will need to unlock the horizontal (**12, Fig. 1**) and vertical (**13, Fig. 1**) lock knobs (just rotate to unlock or lock; when locking, only tighten to a "firm feel," do not overtighten).

Use the viewfinder: If you have not done so, align the viewfinder (**5, Fig. 1**) with the telescope's eyepiece (**1, Fig. 1**) as described earlier.

Look through the viewfinder until you can see the object. It will be easier to locate an object using the viewfinder rather than locating with the eyepiece. Line up the object with the viewfinder's crosshairs.

Look through the eyepiece: Once you have the object lined up in the viewfinder, look through the optical tube's eyepiece. If you have aligned your viewfinder, you will see the object in your eyepiece.

Focus: Look through the eyepiece and practice focusing on the object you have chosen.

Observe the Moon: When you feel comfortable with the viewfinder, the eyepieces, the locks and the adjustment controls, you will be ready to try out the telescope at night. The Moon is the best object to observe the first time you go out at night. Pick a night when the Moon is a crescent. No shadows are seen during a full Moon, making it appear flat and uninteresting.

Look for different features on the Moon. The most obvious features are craters. In fact you can see craters within craters. Some craters have bright lines about them. These are called rays and are the result of material thrown out of the crater when it was struck by a colliding object. The dark areas on the Moon are called maria and are composed of lava from the period when the Moon still had volcanic activity. You can also see mountain ranges and fault lines on the Moon.

Use a neutral density filter (often called a "moon filter") when observing the Moon. Neutral density filters are available from Meade as an optional accessory and enhance contrast to improve your observation of lunar features.

Spend several nights observing the Moon. Some nights, the Moon is so bright that it makes other objects in the sky difficult to see. These are nights that are excellent for lunar observation.

Observe the Solar System: After observing the Moon, you are ready to step up to the next level of observation, the planets. There are four planets that you can easily observe in your telescope: Venus, Mars, Jupiter and Saturn.

Nine planets (maybe more!) travel in a fairly circular pattern around our Sun. Any system of planets orbiting one or more stars is called a solar system. Our Sun, by the way, is a single, yellow dwarf star. It is average as far as stars go and is a middle aged star.

Beyond the planets are clouds of comets, icy planetoids and other debris left over from the birth of our sun. Recently astronomers have found large objects in this area and they may increase the number of planets in our solar system.

The four planets closest to the Sun are rocky and are called the inner planets. Mercury, Venus, Earth and Mars comprise the inner planets. Venus and Mars can be easily seen in your telescope.

Venus is seen before dawn or after sunset, because it is close to the Sun. You can observe Venus going through crescent phases. But you cannot see any surface detail on Venus because it has a very thick atmosphere of gas.

When Mars is close to the Earth, you can see some details on Mars, and sometimes even Mars' polar caps. But quite often, Mars is further away and just appears as a red dot with some dark lines crisscrossing it.

Jupiter, Saturn, Uranus, Neptune and Pluto comprise the outer planets. These planets, except for Pluto, are made mostly of gases and are sometimes called gas giants. If they had grown much bigger, they may have become stars. Pluto is made mostly of ice.

Jupiter is quite interesting to observe. You can see bands across the face of Jupiter. The more time you spend observing these bands, the more detail you will be able to see.

One of the most fascinating sights of Jupiter are its moons. The four largest moons are called the Galilean moons, after the astronomer Galileo, who observed them for the first time. If you've never watched the Galilean moons in your telescope before, you're missing a real treat! Each night, the moons appear in different positions around the Jovian sky. This is sometimes called the Galilean dance. On any given night, you might be able to see the shadow of a moon on the face of Jupiter, see one moon eclipse another or even see a moon emerge from behind Jupiter's giant disk. Drawing the positions of the moons each night is an excellent exercise for novice astronomers.

Any small telescope can see the four Galilean moons of Jupiter, plus a few others, but how many moons does Jupiter actually have? No one knows for sure! Nor are we sure how many Saturn has either. At last count, Jupiter had over 60 moons, and held a small lead over Saturn. Most of these moons are very small and can only be seen with very large telescopes.

Probably the most memorable sight you will see in your telescope is Saturn. Although you may not see many features on the surface of Saturn, its ring structure will steal your breath away. You will probably be able to see a black opening in the rings, known as the Cassini band.

Saturn is not the only planet that has rings, but it is the only set of rings that can be seen with a small telescope. Jupiter's rings cannot be seen from Earth at all—the Voyager spacecraft discovered the ring after it passed Jupiter and looked back at it. It turns out, only with the sunlight shining through them, can the rings be seen. Uranus and Neptune also have faint rings.

Optional color filters help bring out detail and contrast of the planets. Meade offers a line of inexpensive color filters.

Beyond the Solar System: Once you have observed our own system of planets, it's time to really travel far from home and look at stars and other objects.

You can observe thousands of stars with your telescope. At first, you may think stars are just pinpoints of light and aren't very interesting. But look again. There is much information that is revealed in stars.

The first thing you will notice is that not all stars are the same colors. See if you can find blue, orange, yellow, white and red stars. The color of stars sometimes can tell you about the age of a star and the temperature that they burn at.

Other stars to look for are multiple stars. Very often, you can find double (or binary) stars, stars that are very close together. These stars orbit each other. What do you notice about these stars? Are they different colors? Does one seem brighter than the other?

Almost all the stars you can see in the sky are part of our galaxy. A galaxy is a large grouping of stars, containing millions or even billions of stars. Some galaxies form a spiral (like our galaxy, the Milky Way) and other galaxies look more like a large football and are called elliptical galaxies. There are many galaxies that are irregularly shaped and are thought to have been pulled apart because they passed too close to—or even through—a larger galaxy.

You may be able to see the Andromeda galaxy and several others in your telescope. They will appear as small, fuzzy clouds. Only very large telescopes will reveal spiral or elliptical details.

You will also be able to see some nebulas with your scope. Nebula means cloud. Most nebulas are clouds of gas. The two easiest to see in the Northern Hemisphere are the Orion nebula during the winter and the Trifid nebula during the summer. These are large clouds of gas in which new stars are being born. Some nebulas are the remains of stars exploding. These explosions are called supernovas.

When you become an advanced observer you can look for other types of objects such as asteroids, planetary nebula and globular clusters. And if you're lucky, every so often a bright comet appears in the sky, presenting an unforgettable sight.

The more you learn about objects in the sky, the more you will learn to appreciate the sights you see in your telescope. Start a notebook and write down the observations you make each night. Note the time and the date.

Use a compass to make a circle, or trace around the lid of a jar. Draw what you see in your eyepiece inside the circle. The best exercise for drawing is to observe the moons of Jupiter every night or so. Try to make Jupiter and the moons approximately the same size as they look in your eyepiece. You will see that the moons are in a different position every night. As you get better at drawing, try more challenging sights, like a crater system on the moon or even a nebula.

Go to your library or check out the internet for more information about astronomy. Learn about the basics: Light years, orbits, star colors, how stars and planets are formed, red shift, the big bang, what are the different kinds of nebula, what are comets, asteroids and meteors and what is a black hole. The more you learn about astronomy, the more fun, and the more rewarding your telescope will become.

SOME OBSERVING TIPS

Eyepieces: Always begin your observations using the 26mm low-power eyepiece. The 26mm eyepiece delivers a bright, wide field of view and is the best to use for most viewing conditions. Use the high-power 9.7mm eyepiece to view details when observing the Moon and planets. If the image become fuzzy, switch back down to a lower power. Changing eyepieces changes the power or magnification of your telescope.

Barlow lens: You can also change magnification by using a Barlow. Remove the eyepiece from the diagonal mirror and slide in the Barlow. And then place the eyepiece into the Barlow. Tighten the thumbscrews to secure the Barlow lens and the eyepiece in place. The Barlow lens included with your telescope doubles the power of your telescope.

Meade offers a complete line of eyepieces for your telescope. Most astronomers have four or five low-power and high power eyepieces to view different objects and to cope with different viewing conditions.

Objects move in the eyepiece: If you are observing an astronomical object (the Moon, a planet, star, etc.) you will notice that the object will begin to move slowly through the telescopic field of view. This movement is caused by the rotation of the Earth and makes an object move through the telescope's field of view. To keep astronomical objects centered in the field, simply move the telescope on one or both of its axes—vertically and/or horizontally as needed—try using the telescopes coarse and fine adjustment controls. At higher powers, astronomical objects will seem to move through the field of view of the eyepiece more rapidly.

Place the object to be viewed at the edge of the field and, without touching the telescope, watch it drift through the field to the other side before repositioning the telescope so that the object to be viewed is again placed at the edge of the field, ready to be further observed.

Vibrations: Avoid touching the eyepiece while observing through the telescope. Vibrations resulting from such contact will cause the image to move. Avoid observing sites where vibrations cause image movement (for example, near railroad tracks). Viewing from the upper floors of a building may also

cause image movement.

Let your eyes “dark-adapt”: Allow five or ten minutes for your eyes to become “dark adapted” before observing. Use a red-filtered flashlight to protect your night vision when reading star maps, or inspecting the telescope. Do not use a regular flash-light or turn on other lights when observing with a group of other astronomers. You can make your own red filtered flashlight by taping red cellophane over a flashlight lens.

Viewing through windows: Avoid setting up the telescope inside a room and observing through an opened or closed window pane. Images may appear blurred or distorted due to temperature differences between inside and outside air. Also, it is a good idea to allow your telescope to reach the ambient (surrounding) outside temperature before starting an observing session.

When to observe: Planets and other objects viewed low on the horizon often lack sharpness—the same object, when observed higher in the sky, will appear sharper and have greater contrast. Try reducing power (change your eyepiece) if your image is fuzzy or shimmers. Keep in mind that a bright, clear, but smaller image is more interesting than a larger, dimmer, fuzzy one. Using too high a power eyepiece is one of the most common mistakes made by new astronomers.

Dress Warm: Even on summer nights, the air can feel cool or cold as the night wears on. It is important to dress warm or to have a sweater, jacket, gloves, etc., nearby.

Know your observing site: If possible, know the location where you will be observing. Pay attention to holes in the ground and other obstacles. Is it a location where wild animals, such as skunks, snakes, etc., may appear? Are there viewing obstructions such as tall trees, street lights, headlights and so forth? The best locations are dark locations, the darker the better. Deep space objects are easiest to see under dark skies. But it is still possible to observe even in a city.

Surf the Web and visit your local library: The internet contains a huge amount of astronomical information, both for children and adults. Check out astronomy books from your library. Look for star charts—these are available on a monthly basis in *Astronomy* and *Sky and Telescope* magazines.

SPECIFICATIONS

Optical tube focal length 350mm

Objective lens diameter . . 70mm (2.8")

Focal ratio f/5

Mounting type Altazimuth

Viewfinder Size 8 x 21

Barlow 2X

What do the specifications mean?

Optical tube focal length is simply a measurement of the length of the optical tube. In other words, this is the distance light travels in the telescope before being brought to focus in you eyepiece. Your tube is 350mm long.

Objective lens diameter is how big the lens is on your scope. Telescopes are always described by how large their objective lens is. Your telescope is 70mm or 2.8 inches. Other telescopes are 90mm, 8 inches, 16 inches, or even 3 feet in diameter. The Hubble Telescope’s objective lens has a diameter of 2.4 meters (that’s 7.8 feet across!).

The focal ratio helps determine how fast the photographic speed of a telescope is. The lower the focal ratio number, the faster the exposure. f/5 is faster than f/10. The faster the ratio, the faster exposure time is needed when a camera is hooked up to the telescope. Your telescope has a faster focal ratio at f/5. Sometimes, astronomers use focal reducers to make slow exposure telescopes have faster focal ratios.

Altaz mounting simply means your telescope moves up and down (altitude or “alt”), and side to side, (azimuth or “az”). Other mounting configurations are available for other telescopes, such as equatorial mounting.

USE THE SPECIFICATIONS TO CALCULATE THE MAGNIFICATION OF YOUR EYEPIECE

The power of a telescope is how much it magnifies objects. Your 26mm eyepiece magnifies an object 13 times. Your 9mm eyepiece magnifies objects 36 times. But if you obtain other eyepieces, you can calculate how much magnification they have with your telescope. Just divide the focal length of the telescope by the focal length of the eyepiece.

$$\text{FOCAL LENGTH OF THE TELESCOPE} \div \text{FOCAL LENGTH OF THE EYEPIECE} = \text{MAGNIFICATION}$$

Look at the specifications. You will see that the focal length of your scope is 350mm. Let's say that you have obtained a 13mm eyepiece. You can tell that what the focal length of your eyepiece is as it is always printed on the side of an eyepiece. Divide: $350 \div 13$, which equals 26.9. Round this off to the nearest whole number and your new eyepiece magnifies objects 27 times.

If you use your Barlow lens with one of your eyepieces, it doubles the magnification of your eyepiece. Other types of Barlows can triple or further increase the power of an eyepiece. To find out how much your magnification is when you use a Barlow, multiply your eyepiece's magnification by two.

$$\text{EYEPIECE'S MAGNIFICATION} \times 2 = \text{MAGNIFICATION WITH A 2X BARLOW LENS}$$

Your 26mm low-power eyepiece magnifies an object 13 times. Multiply 13 by 2 and you get 26 times magnification with your Barlow.

It's worth repeating: Keep in mind that a bright, clear, but smaller image is more interesting than a larger, dimmer, fuzzy one. Using too high a power eyepiece is one of the most common mistakes made by new astronomers. So don't think that higher magnification is necessarily better—quite often the best view is with lower magnification value!

TAKING CARE OF YOUR TELESCOPE

Your telescope is a precision optical instrument designed for a lifetime of rewarding viewing. It will rarely, if ever, require factory servicing or maintenance. Follow these guidelines to keep your telescope in the best condition:

- Avoid cleaning the telescope's lenses. A little dust on the front surface of the telescope's correcting lens will not cause loss of image quality.
- When absolutely necessary, dust on the front lens should be removed with very gentle strokes of a camel hair brush or blown off with an ear syringe (available at most pharmacies).
- Fingerprints and organic materials on the front lens may be removed with a solution of 3 parts distilled water to 1 part isopropyl alcohol. You may also add 1 drop of biodegradable dishwashing soap per pint of solution. Use soft, white facial tissues and make short, gentle strokes. Change tissues often.

CAUTION: Do not use scented or lotioned tissues or damage could result to the optics. DO NOT use a commercial photographic lens cleaner.

OPTIONAL ACCESSORIES

Additional Eyepieces (1.25" barrel diameter): For higher or lower magnifications with the telescopes that accommodate 1.25" eyepieces, Meade 4-element Series 4000 Super Plössl eyepieces yield wide fields of view with excellent edge-of-field corrections and are available in a range of focal lengths including 6.4, 9.7, 12.4, 15, 20, 26, 32, and 40mm.

Contact your Meade Dealer or see the Meade catalog for more information. Visit us on the web at: meade.com.



MEADE®

6001 Oak Canyon, Irvine, California 92618
(800) 626-3233 ■ www.meade.com

Free Manuals Download Website

<http://myh66.com>

<http://usermanuals.us>

<http://www.somanuals.com>

<http://www.4manuals.cc>

<http://www.manual-lib.com>

<http://www.404manual.com>

<http://www.luxmanual.com>

<http://aubethermostatmanual.com>

Golf course search by state

<http://golfingnear.com>

Email search by domain

<http://emailbydomain.com>

Auto manuals search

<http://auto.somanuals.com>

TV manuals search

<http://tv.somanuals.com>