



MultiView **250A** **Receiver** Quick Reference & Setup Guide



Magenta Research

934 Federal Road, Brookfield, CT 06804 USA
(203) 740-0592 FAX (203) 740-0596
www.magenta-research.com

Magenta Research

934 Federal Road, Brookfield, CT 06804 USA
(203) 740-0592 FAX (203) 740-0596
www.magenta-research.com

**FEDERAL COMMUNICATIONS COMMISSION
AND
INDUSTRY CANADA
RADIO FREQUENCY INTERFERENCE STATEMENTS**

This equipment generates, uses, and can radiate radio-frequency energy, and if not installed and used properly, that is, in strict accordance with the manufacturer's instructions, may cause interference to radio communication. It has been tested and found to comply with the limits for a Class A computing device in accordance with the specifications in Subpart B of Part 15 of FCC rules, which are designed to provide reasonable protection against such interference when the equipment is operated in a commercial environment. Operation of this equipment in a residential area is likely to cause interference, in which case the user at his own expense will be required to take whatever measures may be necessary to correct the interference.

Changes or modifications not expressly approved by the party responsible for compliance could void the user's authority to operate the equipment.

This digital apparatus does not exceed the Class A limits for radio noise emission from digital apparatus set out in the Radio Interference Regulation of Industry Canada.

EUROPEAN UNION DECLARATION OF CONFORMITY

The manufacturer declares that this product meets the requirements of EU Directive 89/336/EEC.



Contents

| Chapter | Page |
|--|------|
| 1. Specifications..... | 3 |
| 2. Introduction | 4 |
| 2.1 Overview..... | 4 |
| 2.2 Equipment You May Also Need..... | 4 |
| 2.3 Compatible Cabling | 4 |
| 3. Setup and Installation..... | 5 |
| 3.1 Cabling Considerations..... | 5 |
| 3.2 Making the Connections..... | 5 |
| 3.2.1 Connections and Setup in General | 5 |
| 3.2.2 Connections on the Single-Port VGA/Audio..... | 6 |
| 3.2.3 Connections on the T4 VGA/Audio Transmitter..... | 7 |
| 3.2.4 A Typical Single-Port Transmitter–Receiver Application | 7 |
| 3.2.5 A Typical Quad T4 Transmitter–Receiver Application..... | 8 |
| 3.3 Configuration Settings..... | 9 |
| 3.4 Video Adjustment..... | 9 |
| 4. Troubleshooting..... | 10 |
| 4.1 Common Problems | 10 |
| Appendix A. Cabling Pinouts..... | 11 |

1. Specifications

Cable Required: Category 5, 5e, 6 shielded or unshielded twisted pair

Compliance: CE; FCC Class A, IC Class/class A

Video Support: to UXGA (1600x1200 @ 70Hz), RGBHV, RGB, Composite, S-Video, Component Video modes

Maximum Resolution and

Refresh Rate: At 250 ft. (76 m) or less, 1600 x 1200 at 70 Hz

Required Source

Impedance: Video OUT: 75 ohms;
Audio OUT (if any): 600 ohms maximum

Required Destination

Impedance: Video IN: 75 ohms;
Audio IN (if any): 600 ohms minimum

Audio

Characteristics: Channels: Right/Left summed;
Line Level 600 Ohm Unbalanced

Connectors: (1) 3.5-mm, (1) RJ-45, (1) HD15 F

Temperature

Tolerance: Operating: 32 to 104°F (0 to 40°C);
Storage: -4 to +140°F (-20 to +60°C)

Humidity

Tolerance: Up to 80% noncondensing

Enclosure: Steel

Power: +5 VDC @ 260 mA max
Consumption: 1.3 watts maximum

Size: 0.88 "H x 3.12"W x 3.75"D (2.2 x 7.9 x 9.5 cm)

Weight: 0.56 lb. (0.26 kg)

2. Introduction

2.1 Overview

Magenta's MultiView™ CAT5 Video System MultiView series extends VGA and audio signals over ordinary Category 5 cable.

This manual covers the Magenta MultiView™ 250A CAT5 Video System Series Receiver with Audio.

For information on the respective transmitter unit, please refer to the appropriate manual included with the transmitter.

WARNING

This equipment is not intended for, nor does it support, distribution through an Ethernet network. Do not connect these devices to any sort of networking or telecommunications equipment!

2.2 Equipment You May Also Need

- 1/8" (3.5mm) Audio cable with RCA jacks.
- Video cable with HD15 connectors.
- CAT5 cable.

2.3 Compatible Cabling

CAT5 cabling for the MultiView™ Series must be pinned to the T568B wiring specification (see appendix A). We also highly recommend that all CAT5 cables be pre-terminated and tested. Cables terminated on-site or in an existing infrastructure should be tested before use to ensure compliance with the T568B specification. Using incorrectly terminated CAT5 cables can damage the Magenta MultiView™ Series.

3. Setup and Installation

3.1 Cabling Considerations

- We recommend mounting and connecting all cabling to the MultiView™ Series components before applying power.
- Make sure that the CAT5 cable you intend to use has been tested to comply with the T568B wiring specification (See **Appendix A**).

3.2 Making the Connections

3.2.1 CONNECTIONS AND SETUP IN GENERAL

This section contains figures showing connections with the specific MultiView™ Series models. In general, however, the connection and setup procedure at both transmitter and receiver ends is as follows:

At the transmitter end (refer to the transmitter user guide) :

1. Connect the source video to the MultiView™ Series transmitter video input port, which is an HD15 connector labeled SOURCE IN.
2. If desired, attach a local monitor via the local monitor port to LOCAL OUT.
3. Make your audio connections via the 1/8" (3.5mm) audio connector or phoenix connector (transmitter model dependent).
4. Connect the CAT5 cable to the transmitter.
5. Apply power on the transmitter. The LED should light and, if there's a local monitor attached, a video image should appear on the monitor's screen.

At the receiver end:

1. Connect the VIDEO OUTPUT HD15 connector to the display unit and attach any audio cabling.
2. Connect a 1/8" (3.5mm) audio cable to the AUDIO OUTPUT connection.
3. Connect the CAT5 cable to the UTP INPUT connection.
4. Apply power. The LED should light and video should appear on the display (make sure display is powered ON).
5. To adjust video levels see **Section 3.4**.

3.2.2 CONNECTIONS ON THE SINGLE-PORT VGA/AUDIO TRANSMITTER

The single-port units with audio support video and audio signals over CAT5 cable. The audio signal is line-level audio, and powered speakers are required. Figure 3-1 shows the MultiView™ Series UTx transmitter with Audio Transmitter connections, and Figure 3-2 shows the MultiView™ MV250A receiver connections.

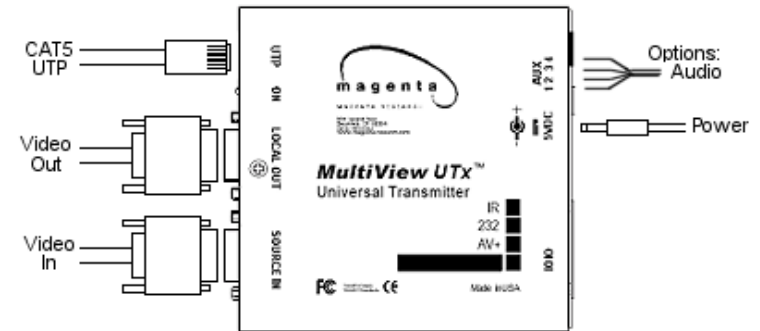

Figure 3-1. Transmitter connections on the UTx Universal Transmitter.

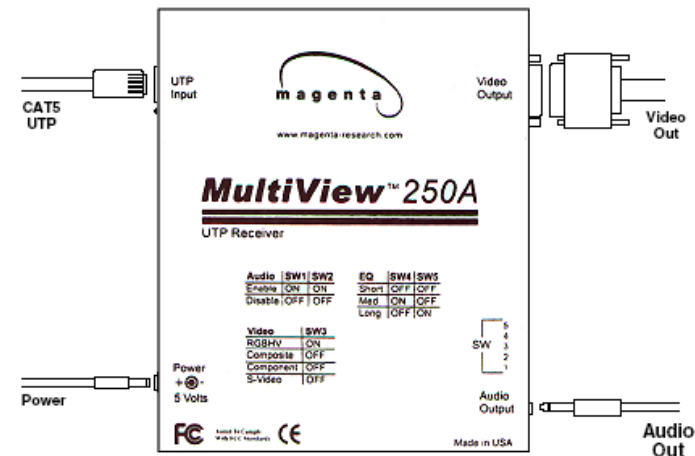

Figure 3-2. Receiver connections on the MultiView 250A.

3.2.3 CONNECTIONS ON THE VGA/AUDIO MULTIVIEW T4 TRANSMITTERS

The MultiView T4 four-port transmitter is used when the same signal is distributed to multiple display devices. You set it up and cable it the same as you would with the single-port transmitter.

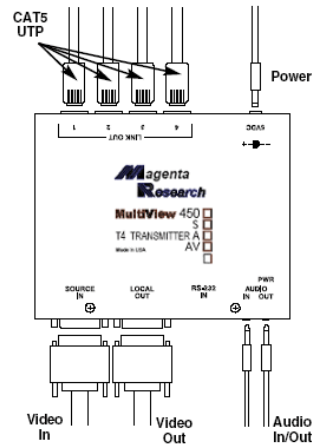

Figure 3-3. T4 Transmitter connections with audio

3.2.4 A TYPICAL SINGLE-PORT TRANSMITTER-RECEIVER APPLICATION

Figure 3-4 shows a typical application in which the single-unit transmitter is connected over CAT5 to a receiver.

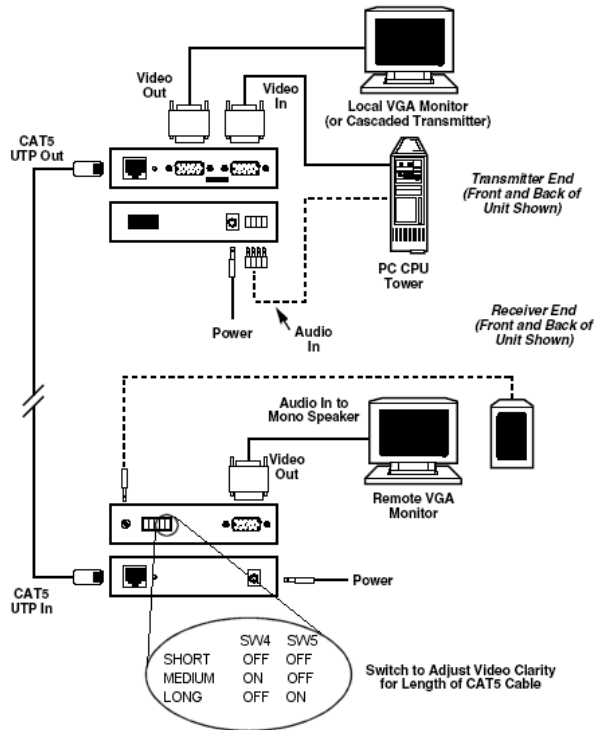

Figure 3-4. Transmitter to Receiver connections.

3.2.5 A TYPICAL MULTIVIEW T4 TRANSMITTER-RECEIVER APPLICATION

Figure 3-5 shows an application in which a MultiView™ Series T4 Transmitter is linked to four MultiView™ Series Receivers.

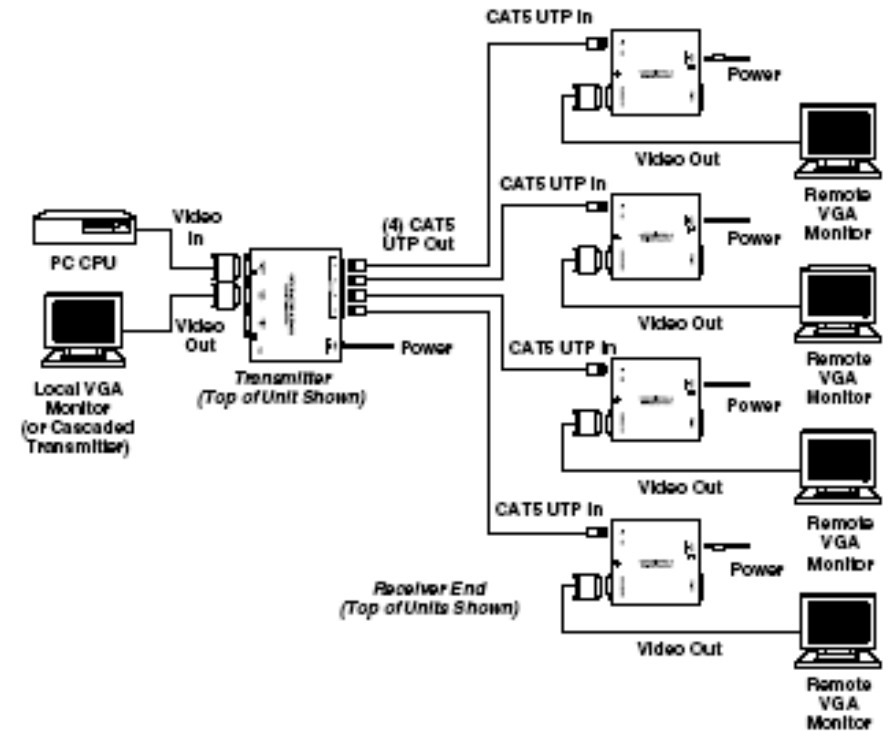

Figure 3-5. MultiView T4 Transmitter to Receiver connections.

3.3 Configuration Settings

The MultiView™ 250A receiver is configurable for various video and audio modes. Note that a compatible transmitter unit must be used at the source end. Reference the appropriate transmitter user guide or call for technical assistance.

A dipswitch on the receiver unit is used to set the video and audio configuration mode. Table 3-1 below shows the configuration settings for SW1 (ON = down, OFF = up):

NOTE:

There are no user serviceable parts inside the MultiView 250A receiver. All adjustments are performed externally.

| SW1 Configuration Settings | | | | |
|----------------------------|---------------------------|-----------|-----|-----|
| | SW1 position | 1 | 2 | 3 |
| Signal | Setting | | | |
| | | L/R Audio | On | ON |
| | | Off | OFF | OFF |
| Video | RGBHV | | | ON |
| | Composite | | | OFF |
| | S-Video | | | OFF |
| | Component | | | OFF |
| AV Mode | Composite + Stereo Audio* | OFF | OFF | OFF |

*AV mode carries all signals on the 15HD Video Output connector. See Appendix A for pinouts

Table 3-1. MultiView 250A Receiver Configuration Settings.

3.4 Video Adjustment

The only adjustments required on the MultiView 250A receiver are the SW1 positions 4 and 5 which must be set to compensate for cable length. Using the table below as a guide, turn SW1 positions ON or OFF for best picture clarity (ON = down, OFF = up):

| Cable distance EQ settings | | |
|----------------------------|-----|-----|
| SW1 position | 4 | 5 |
| Short (0-75 ft) | OFF | OFF |
| Medium (75-150 ft) | ON | OFF |
| Long (150-250 Ft) | OFF | ON |

Table 3-2. Cable Length EQ Settings.

4. Troubleshooting

4.1 Common Problems

In most cases, nearly every issue with the MultiView™ Series can be resolved by checking the CAT5 termination and making sure that it's pinned to the 568B wiring specification. However, there may be other problems that cause the system to not perform as it's designed. Below are solutions to the most common installation errors.

Problem: No video signal at the transmitter local port or at the receiver.

- Solution:**
- Check that both units are powered.
 - **Ensure Cable Length Compensation Switches are set correctly (See Section 3-4).**
 - Make sure the CAT5 cable is terminated correctly per the 568B wiring specification.
 - Is the display device powered on and functioning?

Problem: Poor video quality.

- Solution:**
- Have all receiver adjustments been finished (see section 3.4).
 - Check all cable connections.
 - **Ensure Cable Length Compensation Switches are set correctly (See Section 3-4).**
 - The video signal's refresh rate may be set too high for the display. Reset to a lower refresh rate in your monitor-configuration menu.

Problem: Poor audio quality.

- Solution:**
- Powered speakers are required. Make sure speaker power is ON.
 - Check input source levels from the source device. Make sure the audio source is not overdriven or underdriven.

Problem: "Green shift" or "green washout" on multimedia signals.

- Solution:**
- The standard video model is designed to function with DC coupled signals in which the black level is referenced to 0 volts. Nearly all VGA cards function this way. Some media servers and inexpensive VGA DA's, however, provide AC coupled signals and can cause a green color shift in the video. This is a result of the sync clamping on the red and blue channels of the video/serial model. For five-component (RGB/H&V) AC coupled video, the MultiView™ Series UTx Universal transmitter has been designed with full DC restoration capability. This problem is easily solved via a simple switch setting in the UTx Transmitter. Please refer to the UTx Transmitter user manual.

Appendix A. Cabling Pinouts

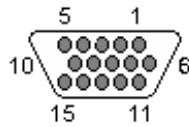

Table A-1. HD15 video connector.

| Pin | RGBHV (VGA) | RGBS | RGsB | Com- posite | SVHS (Y/C) | YUV | Composite Video & Stereo Audio |
|-----|-------------|--------|--------|----------------|------------|-----|--------------------------------|
| 1 | Red + | Red + | Red + | | C+ | V+ | Audio Left |
| 2 | Green+ | Green+ | Green+ | C+ | Y+ | Y+ | C+ |
| 3 | Blue+ | Blue+ | Blue+ | | | U+ | Audio Left |
| 4 | — | — | — | | | | |
| 5 | Gnd | Gnd | Gnd | | | | |
| 6 | Red- | Red- | Red- | | C- | V- | Shield |
| 7 | Green- | Green- | Green- | C- | Y- | Y- | C- |
| 8 | Blue- | Blue- | Blue- | | | U- | Shield |
| 9 | — | — | — | | | | |
| 10 | Gnd | Gnd | — | | | | |
| 11 | Gnd | Gnd | — | | | | |
| 12 | — | — | — | | | | |
| 13 | H Sync | C Sync | — | | | | |
| 14 | V Sync | — | — | | | | |
| 15 | Gnd | Gnd | — | | | | |

Appendix A. Cabling Pinouts

Table A-2. T568B CAT5 pinout

T568B CAT5 Specification

| Pin | Color | Pair |
|-----|--------------|------|
| 1 | Orange/White | 2 |
| 2 | Orange | 2 |
| 3 | Green/White | 3 |
| 4 | Blue | 1 |
| 5 | Blue/White | 1 |
| 6 | Green | 3 |
| 7 | Brown/White | 4 |
| 8 | Brown | 4 |

Cabling must be the same on both ends
Use for Cat5/5e/6

Table A-3. 1/8" (3.5 mm) Audio Connection

| Pin | Channel 1 | Channel 2 |
|--------|-----------|-----------|
| Tip | + | |
| Ring | | + |
| Sleeve | - | - |

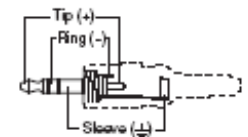

Note: The stereo audio input at the transmitter is summed and output as mono audio on both channels at the receiver.

Free Manuals Download Website

<http://myh66.com>

<http://usermanuals.us>

<http://www.somanuals.com>

<http://www.4manuals.cc>

<http://www.manual-lib.com>

<http://www.404manual.com>

<http://www.luxmanual.com>

<http://aubethermostatmanual.com>

Golf course search by state

<http://golfingnear.com>

Email search by domain

<http://emailbydomain.com>

Auto manuals search

<http://auto.somanuals.com>

TV manuals search

<http://tv.somanuals.com>