

CS 360 XCITE

Cinema Sound Xcite



Owner's manual

Thank you for choosing JBL. For over 60 years, JBL has been involved in every aspect of music and film recording and reproduction, from live performances to monitoring the recordings you play in your home, car or office.

We're confident that the JBL system you have chosen will provide every note of enjoyment that you expected – and that when you think about purchasing additional audio equipment for your home, car or office, you will once again choose JBL.

JBL Consumer Products

Important Safety Instructions

1. Read these instructions.
2. Keep these instructions.
3. Heed all warnings.
4. Follow all instructions.
5. Do not use this apparatus near water.
6. Clean only with a dry cloth.
7. Do not block any ventilation openings. Install in accordance with the manufacturer's instructions.
8. Do not install near any heat sources such as radiators, heat registers, stoves or other apparatus (including amplifiers) that produce heat.
9. Do not defeat the safety purpose of the polarized or grounding-type plug. A polarized plug has two blades with one wider than the other. A grounding-type plug has two blades and a third grounding prong. The wide blade or the third prong is provided for your safety. If the provided plug does not fit into your outlet, consult an electrician for replacement of the obsolete outlet.
10. Protect the power cord from being walked on or pinched, particularly at plugs, convenience receptacles and the point where they exit from the apparatus.
11. Only use attachments/accessories specified by the manufacturer.
12. Use only with the cart, stand, tripod, bracket or table specified by the manufacturer or sold with the apparatus. When a cart is used, use caution when moving the cart/apparatus combination to avoid injury from tip-over. 
13. Unplug this apparatus during lightning storms or when unused for long periods of time.
14. Refer all servicing to qualified service personnel. Servicing is required when the apparatus has been damaged in any way, such as power-supply cord or plug is damaged, liquid has been spilled or objects have fallen into the apparatus, the apparatus has been exposed to rain or moisture, does not operate normally, or has been dropped.
15. Do not expose this apparatus to dripping or splashing and ensure that no objects filled with liquids, such as vases, are placed on the apparatus.
16. To completely disconnect this apparatus from the AC Mains, disconnect the power supply cord plug from the AC receptacle.
17. The mains plug of the power supply cord shall remain readily operable.
18. Do not expose batteries to excessive heat such as sunshine, fire or the like.

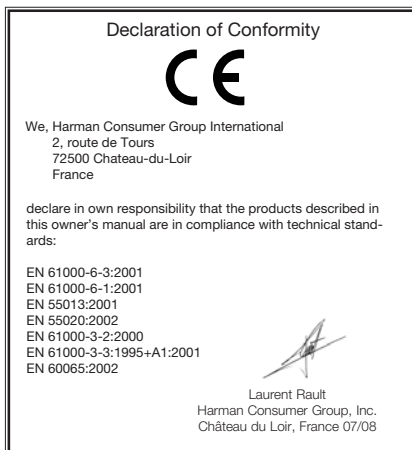

Important Note

Function of Automatic On/Off and Automatic Input Selector

The Xcite offers two unique user-convenience features: Automatic Turn On/Turn Off and Automatic Input Selector.

The Automatic Turn-On feature will turn the Xcite on as soon as a source connected to its inputs is switched on.

These functions work with any Input, Digital or Analog.

The Automatic Turn-On feature will turn the Xcite ON and select the proper Input as soon as a Source connected to its Digital Inputs is switched ON, or Source connected to Analog Inputs starts playing.

The Automatic Turn-Off shuts the unit down five minutes after a currently selected Digital Source is powered down, or the device connected to its currently selected Analog Input stops playing.

If a signal is present at any other Input when a currently selected Digital device is turned Off, or when a currently selected Analog device stops playing for more than 15 seconds, the Xcite system does NOT switch over to this other Input, but turns OFF after five minutes.

If any new signal is applied, which was not active at the time when the signal of the currently selected Input is removed, Xcite will switch to the Input where the new signal is detected.

The Automatic Turn-On can be disabled in the SETUP menu.

The Automatic Source Selector can be disabled in the SETUP menu.

The Automatic Turn-Off cannot be disabled.

These functions are working regardless of how the current Source is selected, automatically or manually.

Included

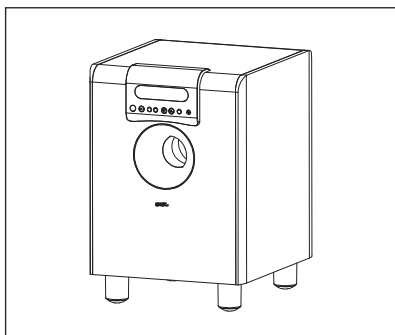

“Smart” powered subwoofer/controller.

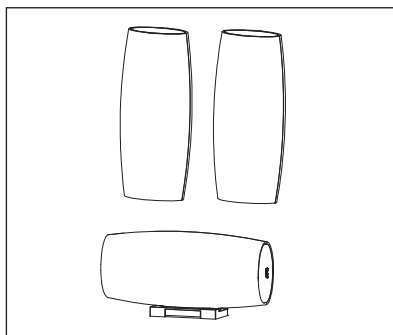

2 satellites and a center channel loudspeaker with Remote Control Sensor.

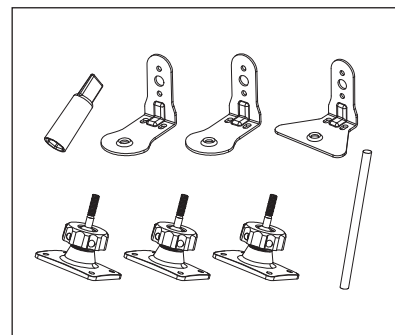

Two fixed wall brackets for satellites, one for center. Three adjustable wall brackets with tightening bar. Speaker terminal wrench.

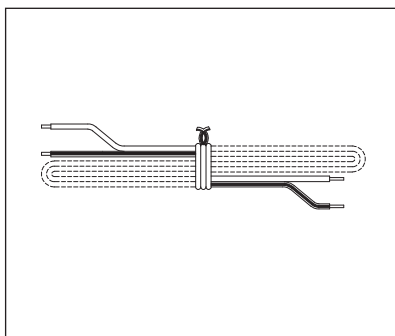

JBL speaker cables.

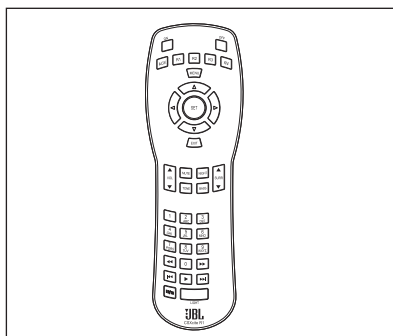

Remote control with batteries.

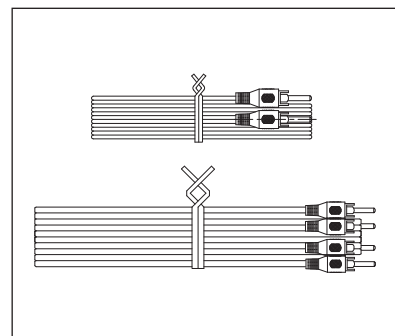

Digital coax input cable and analog RCA input cable.

Features

- Complete, self-powered DTS, Dolby* Digital surround processor with two satellite speakers, a center channel loudspeaker, subwoofer, remote control, and all amplification built-in.
(Just Add TV and source unit!)
- Dolby Digital, DTS, Dolby Pro Logic II*, including Phantom and 3-Stereo, and Stereo listening modes.
- SRS TruSurround HD™ 2.1 and 3.1 with independently selectable SRS TruBass®.
- Automatic Turn-On and Turn-Off.
- Turn-On can be disabled.
- Automatic Source Switching for the all inputs.
- Two digital (one optical and one coaxial) inputs and two analog inputs.
- 2-Way video-shielded satellites with titanium-laminate tweeters and common voicing for all three channels, and a 6.5", long-throw, floor-firing subwoofer.
- Late Night compression for nighttime listening without unexpected and objectionably loud passages.
- All amplification and controls are mounted in the subwoofer, eliminating the need for a separate control unit.
- Remote controllable via outboard remote eye attached to the center channel so that the subwoofer may be hidden away. The remote eye may be detached from the center channel and placed independently.
- Adjustable and fixed wall-mount brackets.
- Full-function remote control.
- All necessary cables included.
- Center foot for horizontal placement of the center channel.

Speaker Placement

Before deciding where to best place your speakers, survey your room and study Figures 1 and 2.

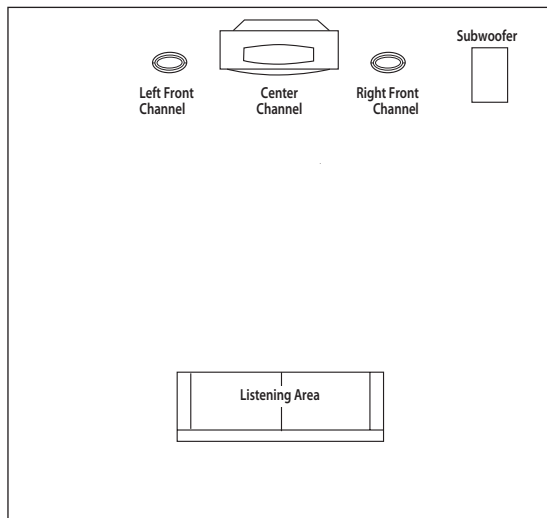

Figure 1. In this overhead view of a typical installation, satellite speakers are used to reproduce sound for the front. The center channel reproduces sound and dialogue. The powered subwoofer provides bass for effects and music.

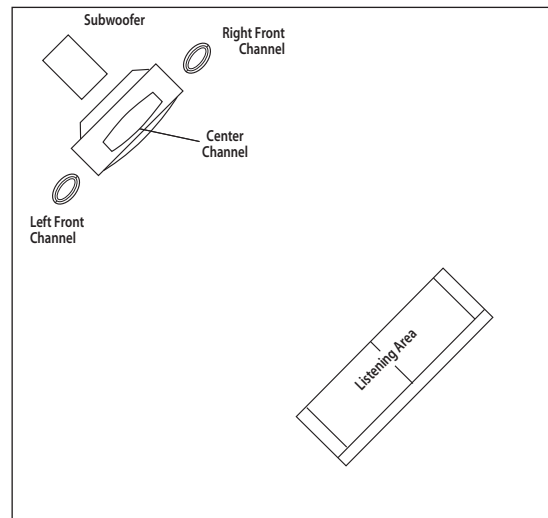

Figure 2. This figure shows an alternative layout, which may be more suitable for some rooms.

Left and Right Front Channels

For left and right front channels, place one satellite to the left and another to the right of the television, as shown in Figure 1.

Since the speakers are magnetically shielded, you can place them very close to the TV without worrying about the magnetic field distorting the picture.

Center Channel

For the center channel, place the speaker directly on top of, or below, your television. Use a shelf or one of the included wall brackets if the television does not provide a stable platform.

Subwoofer

Since the installation of a subwoofer can be somewhat more complicated than installing full-range speakers, it is essential that you read this section very carefully prior to connecting the subwoofer to your system. Should you have questions relating to installation, it is advisable to call either your dealer or JBL's Customer Service Department for advice.

The performance of the subwoofer is directly related to its placement in the listening room and how the subwoofer is aligned with the satellite speakers. Setting the volume

of the subwoofer in relation to the left and right speakers is also of critical importance because it's essential that the subwoofer integrate smoothly with the entire system. Setting the subwoofer's volume level too high will result in an overpowering, boomy bass. Setting the volume level too low will negate the benefits of the subwoofer.

Here are several additional facts on installation that may prove useful. It is generally believed that low frequencies (below 125Hz) are nondirectional and, therefore, placement of a subwoofer within any listening room is not critical. While in theory it is true that the larger wavelengths of extremely low frequencies are basically nondirectional, the fact is that, when installing a subwoofer within the limited confines of a room, reflections, standing waves and absorptions generated within the room will strongly influence the performance of any subwoofer system. As a result, specific location of the subwoofer becomes important, and we strongly recommend that you experiment with placement before choosing a final location. Placement will depend upon your room (for example, whether or not your room permits placement of the subwoofer near either satellite) and the amount and quality of bass required.

Wall-Mounting the Satellites and Center Channel

The CS360 satellites and center channel are designed to be mounted on the wall. There is a fixed-mount wall bracket and an adjustable wall bracket provided for each satellite and the center channel. Each speaker bracket will require up to four 38 mm (1-1/2") #10 wood screws; each screw should be fastened to a wall stud. If a wall stud is unavailable, install an anchor appropriate for a 38 mm (1-1/2") #10 screw.

NOTE: The customer is responsible for the correct selection and use of mounting hardware (available through hardware stores) that will ensure the proper and safe wall-mounting of the speakers.

Fixed-Mount Wall Bracket

Step 1. Mark the positions on the wall where you would like to place the mounting screws.

Step 2. Attach the bracket to the wall using two screws (not included).

Step 3. Remove the rubber ring on the bottom of the satellite and hold the satellite or center channel speaker in the right position on the bracket.

Step 4. Attach the short Phillips screw into insert on bottom of speaker and tighten.

Step 5. Attach speaker wire as shown on page 7.



NOTE: The fixed-mount wall bracket for the center speaker is the one with the wide support plate. The center speaker has to be mounted horizontally when using the fixed-mount bracket. See image on page 4. In order to attach this bracket, first detach the stand and remote sensor that are fixed to the center speaker from the factory. Simply loosen and remove the large Phillips screw at the bottom of the stand. The remote sensor and the stand come off as two separate items, and you may now position the remote sensor freely, if you decide to use it. The bracket should be attached to the wall first, then the cables should be connected to the speaker, and finally you can attach the speaker to the bracket with the large Phillips screw from beneath.

Adjustable Wall Bracket

Step 1. Remove cap over threaded insert on rear of speaker.

Step 2. Mark the positions on the wall where you would like to place the mounting screws.

Step 3. Place bracket against the wall and fasten four 38 mm (1-1/2") #10 wood screws through the bracket's screw holes into the wall. If a wall stud is not available, use an appropriate anchor.

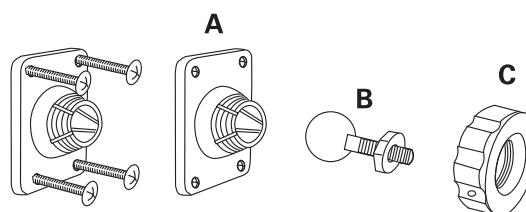

Step 4. Unscrew round collar (C) from bracket (A).

Step 5. Screw the ball and shaft assembly (B) to the short Phillips screw insert on the back of the satellite or the center channel (do not use the bottom insert on either speaker). Back out 1/2 of a turn and tighten the nut against the speaker. If the ball and shaft assembly is not backed out before tightening the nut, performing Step 8 below may dislodge the threaded insert in the speaker housing and permanently damage the speaker.

Step 6. Attach speaker wire as shown on page 7.

Step 7. Drop round collar (C) over ball and shaft assembly (B) that is mounted to the speaker with the finished side of the collar facing the rear of the speaker.

Step 8. Carefully push the ball straight into the socket mounted on the wall, angle the speaker as desired and tighten the collar using the enclosed metal bar.

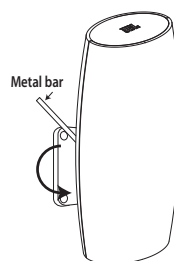

Figure 3. Bracket on wall

Before mounting the center speaker on an adjustable wall bracket, remove the base and remote sensor assembly as described under "Fixed-Mount Wall Bracket" above.

Center and Satellite Speaker Connections

Turn Off All Power

After placing the speakers, you are ready to connect your system. First, turn off all audio-system power.

Use the speaker wire included (or similar) to make your connections. The side of the wire with a ridge or other coding is usually considered positive polarity (i.e., +).

Satellites

Observe polarities when making speaker connections, as shown in Figure 4. Connect each + terminal on the back of the subwoofer to the respective + (red) terminal on each speaker. Connect the – (black) terminals in the same way.

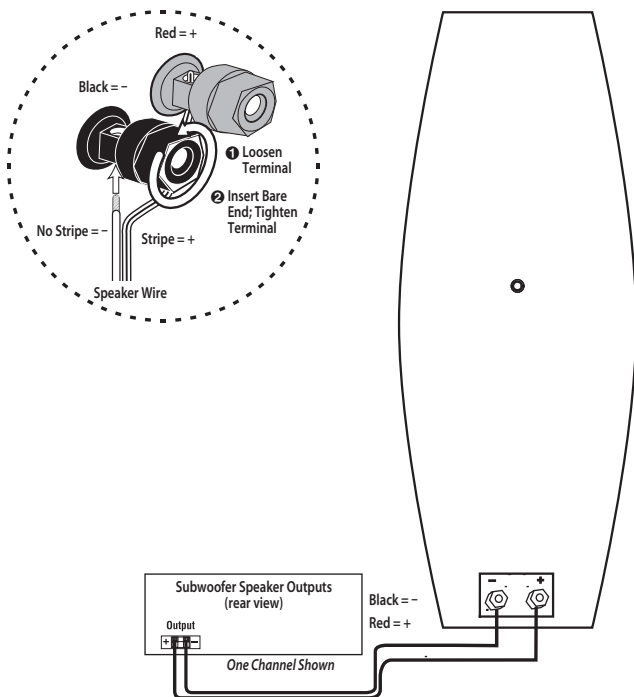

Figure 4. Wiring diagram shows polarity connections for one channel of a home theater system.

Center Channel

Observe polarities when making speaker connections, as shown in Figure 5. Connect the center channel + terminal on the back of the subwoofer to the + (red) terminal on the center speaker. Connect the – (black) terminals in the same way.

Important!

Do not reverse polarities (i.e., + to –, or – to +) when making connections. Doing so will cause poor imaging and diminished bass response. Be certain that positive and negative wire strands are completely isolated to avoid short circuits that may damage your equipment.

NOTE: A small socket wrench is provided to help in properly tightening the terminals. Hand-tighten only and do not overtighten.

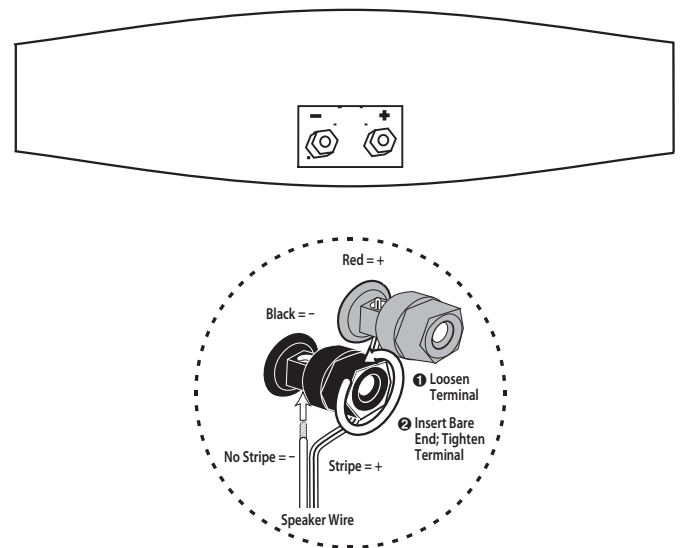
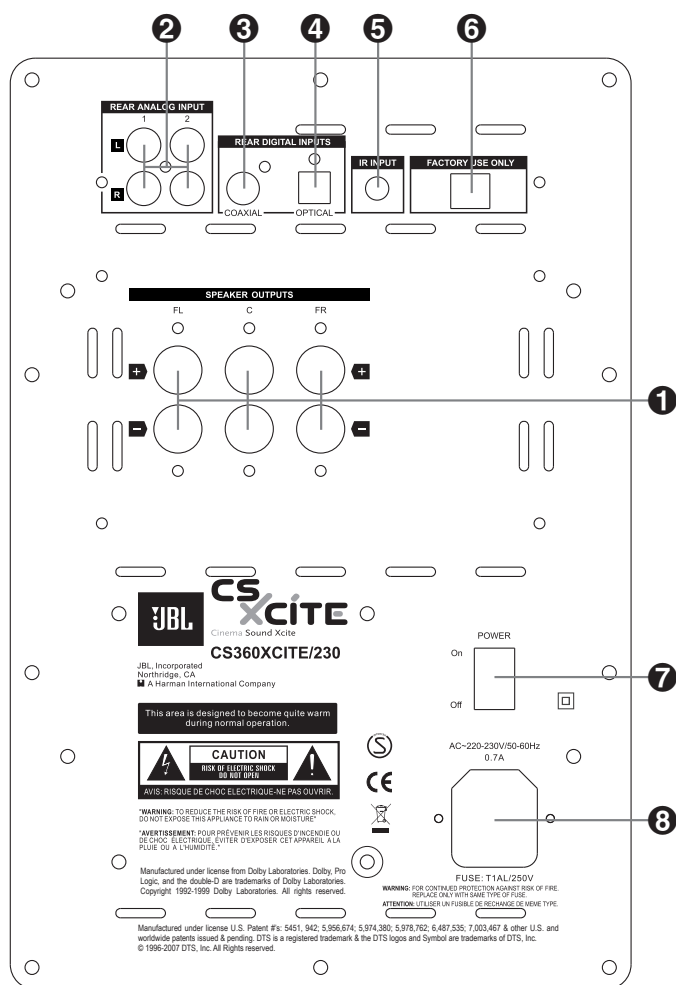

Figure 5. The satellites and center channel speaker feature terminals that can be connected in several different ways – e.g., spade terminals and direct wiring (as shown here).

Speaker, Source, and Remote-Sensor Connectors (rear panel of subwoofer)



1 Speaker Outputs

Connect the three speakers here with the speaker wire in the box, or other suitable wire. There is a Plus (+) and a Minus (-) wire to each speaker. FL is Front Left speaker, C is Center, FR is Front Right.

2 Analog Inputs

1 and 2

Connect analog audio outputs from a TV, a DVD or CD player or any other (line level, not record players) source with analog left and right RCA phono plug outputs to the two RCA phono sockets on one of these inputs. An analog RCA cable is included with the system.

3 Coaxial Digital Input

Connect the coaxial digital output of a DVD or CD player to this socket. A digital RCA cable is included with the system.

4 Optical (TOS Link) Digital Input

Connect the optical digital output of any digital source (MP3 player, portable CD player, stationary DVD or CD player) to this TOS Link socket. A TOS Link cable must be purchased separately.

5 Infrared Input

If you prefer to place the subwoofer somewhere discreet, the infrared sensor on its front panel may not be able to receive commands from your remote control. In this case, use the extra infrared receiver placed underneath the center speaker instead. The separate sensor has a 3,5mm stereo mini-jack, which plugs into this socket. Both sensors are active simultaneously.

6 Data connection for factory use only

7 Power On/Off Switch

When in OFF position, this switch disconnects the system completely from AC power. This means that there is no stand-by power consumption, and the system cannot be switched on with the remote control. It is recommended to set this switch to OFF when not using the system for a prolonged period of time. Switch to ON to permit normal operation.

8 AC Power Cord Socket and Fuse

Insert the proper end of the power cord here, the other end into a wall socket. If the internal fuse should blow, pry open the small drawer beneath the AC plug with a screwdriver to slide out the fuse.

Remote and Front-Panel Controls and Indicators

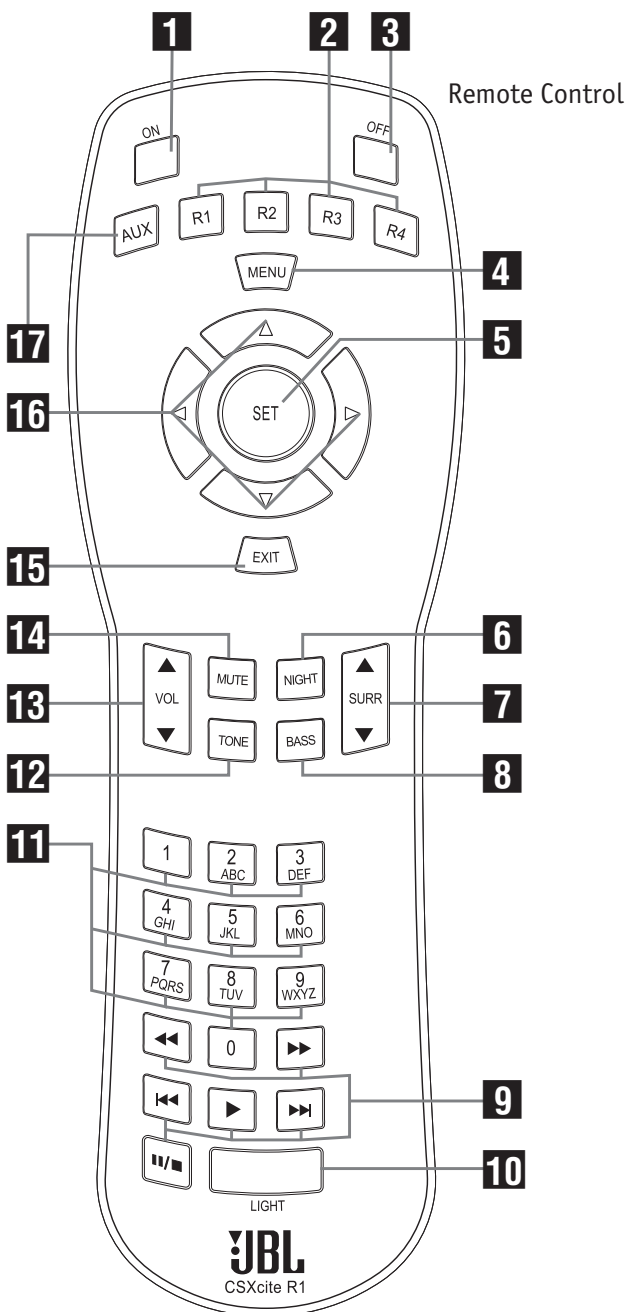
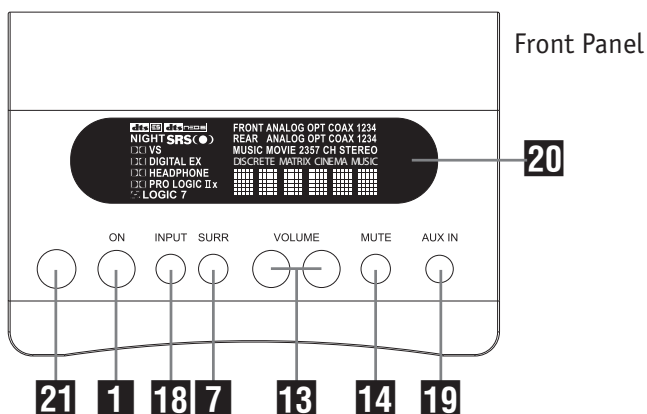

1 Power ON (Remote and Front Panel)

On the Remote Control, the ON Button turns the unit ON, while Button **3** turns the unit to STANDBY. On the Subwoofer Front Panel, the ON Button is a combined ON/OFF Button that toggles between ON and STANDBY. The display briefly shows PWR ON or PWROFF while this is happening. Please note that the Xcite features Automatic Turn-On/Off, and the power switch is not normally used unless it is necessary to override this automatic feature. Please read the details regarding Automatic Turn-On/Off on page 3 of this manual.

When the Xcite is plugged into a working electrical outlet and its master switch on the back panel is set to On, the Standby light in the ON Button on the front panel will illuminate. The display window will light as soon as the Xcite is turned on either automatically or via the pressing of the ON Button on the Remote Control or Front Panel.

2 Direct Input Selector Buttons (Remote Only)

Access each of the four Inputs on the rear panel with the Buttons R1 to R4. Under normal day-to-day use, the Automatic Source Selection System either uses the last Input that you listened to, or switches to the appropriate Source when you power it up. Only when this system does not work, or if you wish to alternate between two or three signal sources, do these buttons come in handy.

3 OFF Button (Remote Only)

Switches the system off.

4 Menu Button (Remote Only)

See page 11 for an explanation of the Menu/Setup procedures.

5 Set Button (Remote Only)

Use this Button to confirm your selection in the Menu/Setup procedures.

6 Night (Remote Only)

This feature is available for Dolby Digital only. It compresses the inherently dynamic digital sound so that the quiet and loud passages are not quite as different in sound levels as they ordinarily are. This feature allows the user to watch movies and listen to dialogue at toned-down levels so as not to disturb others by the loud sound effects that may be present. The word NIGHT lights up in the display when this feature is active.

7 Surround Mode (Remote and Front Panel)

Press the SURR Button on the Front Panel repeatedly to scroll through the various Surround and Stereo options. The SURR UP/DOWN Button on the Remote Control lets you scroll either up or down through the same modes.

8 Bass (Remote Only)

Press this Button to select Bass Enhancement in certain Surround Modes. If no options are available for a certain Surround Mode, the Display shows N/A (Not Applicable).

9 Transport Control Buttons (Remote Only).

Use these six buttons to control Start, Stop, Pause, Search and Skip on compatible DVD players.

10 Light Button (Remote Only)

Press this Button to activate the background light in the Remote Buttons for easy operation in a dark room. The light stays on for some seconds, then switches off.

11 Alphanumeric Buttons (Remote Only)

Can be used to enter digits when naming Inputs.

12 Tone (Remote Only)

Press the Tone Button to activate and switch between Bass and Treble. When the word BASS or TREBLE appears in the Information Display, press the UP or DOWN Buttons **16** to increase or decrease the Bass or Treble level. The amount of adjustment is shown in the Display with digits from +15 to -15. If you press no button, the system returns to normal operation. Pressing the EXIT Button **15** also returns the system to normal operation.

13 Volume (Remote and Front Panel)

Press (∧) on the remote control or the front panel to raise the system's volume. Press (∨) on the remote control or the front panel to lower the system's volume. The volume setting is indicated with digits from 0 to 99 in the Information Display.

14 Mute Button (Remote and Front Panel)

Press this Button to completely silence the system. The word MUTE blinks in the display. Press the Mute Button again to end the function.

Note: The mute function can also be turned off by pressing either of the volume buttons on the front panel or the remote control.

15 Exit Button (Remote Only)

Press the Exit Button to stop a process and leave menus or functions.

16 Navigation Buttons (Remote Only)

Use these four Buttons to navigate through the menus.

17 AUX Button (Remote Only)

Press the AUX Button to listen to a music player connected to the Front Panel AUX IN 3,5mm stereo jack **19**.

18 Input (Front Panel Only)

This control is available on the front panel. It allows manual selection when the user repeatedly presses and releases the button for any of the Xcite's five inputs. The Xcite features an Automatic Input Selection feature that automatically switches the Xcite to the source connected to one of its two digital inputs as soon as that device is powered on. Please read the section on page 3 to thoroughly familiarize yourself with the conveniences and conditions of using the Automatic Input Selection feature.

19 AUX IN (Front Panel Only)

This 3,5mm stereo jack permits easy connection of such units as an MP3 Player, portable CD Player or the sound output from a video camera. Select AUX with Button **17** on the Remote Control, or by scrolling through the Inputs until you get to AUX with Button **18** (INPUT) on the Front Panel.

20 Information Display (Front Panel Only)

This Display window shows all information regarding operation and status for the system. When entering a command, the information first scrolls across the lower part of the Display, making even longer texts legible. After the scrolling text, a fixed text that may be abbreviated appears. Also, the Display shows a number of standard informative words or logos according to your selections.

21 Infrared Sensor Window (On Front Panel and Center Speaker)

This Sensor receives all commands from the Remote Control and should not be covered. In case you prefer to place the Subwoofer in a hidden position, the Remote Sensor Extension may be used instead. Please refer to separate explanation of this sensor.

SETUP PROCEDURE (via Remote Control Only):

The CS360 System enters SETUP when you press and hold the MENU Button on the Remote Control for 3 seconds.

The Front Display now shows the word TEST blinking. Press the [<] or [>] Navigation Button **16** on the Remote to scroll through the options. If scrolling with the Right Navigation Button, the Display shows these (blinking) words in the following order:

TEST – LEVELS – UNITS – DISTNC – LIPSNC – DISPLY – ON VOL – NAME – AU ON – AU SRC – RESET? – And TEST again.

Select any of these functions for adjustment by pressing the SET Button **5** on the Remote. See below for explanation of each adjustment.

If you want to leave the SETUP Mode at any time, press the EXIT Button **15** on the Remote once or twice.

NOTE: If the unit is left in SETUP mode or its sub-menus for 60 seconds without any user commands, the unit leaves SETUP menu and returns to regular operation.

NOTE: In SETUP, when a selection has sub-selections (such as LEVELS having a sub-selection of Front Left, Center, Front Right,), this selection blinks to prompt you to press SET to enter the next menu layer. If a menu item offers no further options (such as Front Left Speaker in the LEVELS menu), the indication does not blink.

DESCRIPTION OF EACH SETUP FUNCTION

To enter the SETUP menu, first press the MENU Button for two seconds. When the Display shows the word TEST blinking, either acknowledge with the SET Button to enter the TEST tone menu, or move forwards or back between the Setup options with the RIGHT ARROW or LEFT ARROW Buttons. The following explanations follow the Setup Functions as you see them if using the RIGHT ARROW to circulate through the menus.

TEST:

After pressing the SET Button, a pink noise test signal circulates between the three speakers and the subwoofer, (sound from the subwoofer only if SUBWFR is ON). While the test signal is heard from each speaker, the Display shows which one you are listening to, as well as the level. (FL for Front Left, C for Center, FR for Front Right, S for Subwoofer). Adjust the output level by pressing the Up or Down Navigation Buttons. Initial level for all speakers is shown as "0", and may be increased to +10 or decreased to -10, except the subwoofer, which may be increased to +20. The noise is heard from each speaker for 5 seconds, and if no action or adjustment is done, it goes to the next speaker. You can circulate between the speakers quickly by pressing the RIGHT ARROW Button. The system stays in TEST mode until you press EXIT or SET. SET or first press of EXIT will take you to the next SETUP item (LEVELS). A second press of EXIT button will cause the system to leave the SETUP menu.

LEVELS:

Here you can adjust the level of each speaker while listening to normal music or any other program material of your choice. (No test tone or pink noise is heard). Press SET when LEVELS blinks on the Display. The Display shows "FL 0" for Front Left Channel, standard level. Increase or decrease the Level with the Up and Down Navigation Buttons, and move through the four speakers with the Left and Right Navigation Buttons, adjusting each one according to taste. When you are done, press SET or EXIT to jump to the next SETUP item.

UNITS:

Units lets you select either meters or feet for setting speaker distances. This selection is relevant only if you want to adjust Distance (next point).

DISTNC:

Adjusts perceived speaker Distance from user by adding delay. Select each speaker in turn with the Left and Right Navigation Buttons and adjust the distance from 0.0 meters to 9.0 meters to reflect the actual distance between yourself and each speaker. Press SET or EXIT to jump to the next item.

LIPSNC:

Lip Sync delays audio so that it is in sync with video that may be delayed due to processing. When the Display shows LIPSNC blinking, press SET. The Display now shows the standard value of 50 ms (milliseconds). You may adjust the Delay in 5 ms increments from 0 ms to 100 ms by pressing the Up and Down Navigation Buttons. Adjust until audio from the speakers follows the lip movements on the TV screen. Press SET or EXIT to save the setting and move to next adjustment.

DISPLY:

The Display option lets you choose between either Timeout YES or NO with the Left and Right Navigation Buttons. If you select T/O NO, the Display shows information at all times. If you select T/O YES, the Display goes dark three seconds after your last action.

Please note that when you have selected Time Out YES, most of the commands from the Remote Control must be sent twice, first time to activate the Display, second time to perform the command. However, if Power Off, Volume Up, Volume Down or Mute is pressed when the Display is dark, it lights up, but the command is also executed. If you select Timeout NO, only one press on any Button is necessary, as there is no need to wake up the Display first.

Press SET or EXIT to save the setting and move to next adjustment.

ON VOL:

On Vol lets you decide the start-up Volume of the system. Press SET when ON VOL blinks. Now you can choose between OV OFF or OV plus a number with the Right and Left Navigation Buttons. OV OFF means that the system is silent when you switch it on, and you must increase the Volume from zero to desired volume every time it has been switched off. OV60 means that the system always starts up at the volume represented by the number 60. This number can be changed from 0 and up, in increments of one. If you select OVxx, you can increase and decrease the startup volume (and the number) with the Up and Down Navigation Buttons, and you can hear the actual volume while you are changing it. Just choose a comfortable startup volume, followed by a press on SET or EXIT to save the setting and move to the next adjustment. If you do nothing for three seconds, the system reverts to the Setup Menu by itself.

NAME:

Permits you to add a name to any Input, up to six characters long.

When NAME blinks in the Display, press SET. The name of the first input is shown in the dot-matrix display line, with the entire name blinking above in the fixed-character section. You may now jump from input to input with the Left and Right Navigation Buttons until you see the one you want to name. (If you are listening to a signal source, it remains active while you rename any or all inputs). Now press SET again. The first character blinks. Now use the Up and Down Navigation Buttons to run through the letters of the alphabet, the digits 0-9 and various symbols. Search forwards or backwards. When you have run through all characters, the list begins again from the start. You can also select digits directly with the 0-9 alphanumeric buttons. Confirm your selection and jump to the next one (which now blinks) with the Right Navigation Button. Repeat the procedure until the name is entered, then press SET to skip to the next input. When you are done naming inputs, press EXIT once to skip to the next Setup item, or twice to leave Setup.

AU ON:

Activates or deactivates the AUTO TURN ON feature. This feature is explained at the start of this manual, but briefly it automatically switches the system ON when it senses a signal. The default setting is YES. With AU ON blinking, press SET on the Remote. You can select YES (not blinking) or NO (not blinking) with the Left and Right Navigation Buttons. Confirm your selection by pressing SET again, or press EXIT to skip to the next Setup item.

AU SRC:

Activates or deactivates the AUTO SOURCE SELECTION feature, which senses what Input you are currently using. The default setting is YES. If you would prefer to do the Input selection manually, choose NO. With AU SRC blinking press SET on the Remote. You can select YES (not blinking) or NO (not blinking) with the Left and Right Navigation Buttons. Confirm your selection by pressing SET again, or press EXIT to skip to the next Setup item.

RESET?

If you press SET, when RESET? is shown blinking, the Display asks you to confirm with the word **SURE?** blinking. If you press EXIT now, nothing is reset, and the unit leaves the SETUP menu. If user press SET once again, all SETUP settings go back to factory default settings. RESET also sets BASS and TREBLE settings back to 0:

Surround Modes

Phantom

This mode creates surround sound from stereo recordings. The center channel is not used and the surround channels have a 20-ms delay.

3-Stereo Mode

Use this mode to play back Pro Logic-encoded films when you do not want the surround channels to play.

Stereo

This mode plays a recording in traditional two-channel stereo.

DOLBY DIGITAL			SURROUND MODE	STREAM TYPE
[1.0][1.1] [3.0][3.1] [2/1.0][2/1.1] [3/1.0][3/1.1] [2/2.0] [2/2.1]	[3/2.0] [3/2.1]	[2.0][2.1]		
48K	48K	48K		
		X	DOLBY 3 STEREO	3CH ST
		X	DOLBY 2 STEREO	2CH ST
X	X		DOLBY DIGITAL	DOLBY
	X	X	DOLBY VIRTUAL 2CH WIDE	VSWIDE
	X	X	DOLBY VIRTUAL 2CH REF	VS REF
	X		DOLBY VIRTUAL 3CH WIDE	VSWIDE
	X		DOLBY VIRTUAL 3CH REF	VS REF
		X	DOLBY PL2 MUSIC VIRTUAL 3CH WIDE	VSWIDE
		X	DOLBY PL2 MUSIC VIRTUAL 3CH REF	VS REF
		X	DOLBY PL2 MOVIE VIRTUAL 3CH WIDE	VSWIDE
		X	DOLBY PL2 MOVIE VIRTUAL 3CH REF	VS REF
X	X	X	DOLBY SRS TRUSURROUND	SRS TS

DTS			SURROUND MODE	STREAM TYPE
[1.0][1.1] [3.0][3.1] [2/1.0][2/1.1] [3/1.0][3/1.1] [2/2.0] [2/2.1]	[3/2.0] [3/2.1]	[2.0][2.1]		
48K	48K	48K		
		X	DTS 3 STEREO	3CH ST
		X	DTS 2 STEREO	2CH ST
X	X		DTS	DTS
	X	X	DTS VIRTUAL 2CH WIDE	VSWIDE
	X	X	DTS VIRTUAL 2CH REF	VS REF
	X		DTS VIRTUAL 3CH WIDE	VSWIDE
	X		DTS VIRTUAL 3CH REF	VS REF
		X	NEO6 MUSIC VIRTUAL 3CH WIDE	VSWIDE
		X	NEO6 MUSIC VIRTUAL 3CH REF	VS REF
		X	NEO6 CINEMA VIRTUAL 3CH WIDE	VSWIDE
		X	NEO6 CINEMA VIRTUAL 3CH REF	VS REF
X	X	X	DTS SRS TRUSURROUND	SRS TS

PCM				SURROUND MODE	STREAM TYPE
DIGITAL			ANALOG		
192K	96K	48K			
X	X	X	X	PCM 3 STEREO	3CH ST
X	X	X	X	PCM 2 STEREO	2CH ST
		X	X	PL2 MUSIC VIRTUAL 3CH WIDE	VSWIDE
		X	X	PL2 MUSIC VIRTUAL 3CH REF	VS REF
		X	X	PL2 MOVIE VIRTUAL 3CH WIDE	VSWIDE
		X	X	PL2 MOVIE VIRTUAL 3CH REF	VS REF
	X	X	X	NEO6 MUSIC	Neo:6
	X	X	X	NEO6 CINEMA	Neo:6
		X	X	PCM VIRTUAL 2CH WIDE	VSWIDE
		X	X	PCM VIRTUAL 2CH REF	VS REF
	X	X	X	PCM SRS TRUSURROUND	SRS TS

Troubleshooting

If there is no sound from any of the speakers:

- Make sure the subwoofer is plugged into an active AC wall outlet.
- Make sure the Master Power Switch, located on the rear of the subwoofer, is in the On/Standby position.
- Make sure there is a source – for example, a DVD Player, CD Player, VCR or television – hooked up to one of the four input jacks.
- Make sure that the program material is playing.
- Recheck the hookup connections, referring to the Speaker Connections section.

If there is no sound from the center speaker:

- Make sure that the processor is in the 3-Stereo mode. If it is in Phantom or Stereo mode, the center speaker will not play.
- Increase the level of the center channel, using the level-adjustment instructions earlier in this manual.
- Check the connections between the subwoofer and the center speaker.

If you have low bass output:

- Experiment with placement of the subwoofer. Remember, place the subwoofer in a corner to get maximum bass output from the system.
- Increase the subwoofer level, using the level-adjustment instructions found earlier in this manual.
- Increase the level of bass, using the remote control.

The internal software version may be checked by pressing the ON Button on the remote when the unit is already switched ON. The software version number appears as a small "v", followed by a sequence of digits.



Optional Floor Stands are available from your JBL Dealer (Order code: CSSTANDS).

Specifications

CSXcite System 3.1

Power Output

Satellites and Center:	30 Watts x 3 @ 1% THD
Transducers Satellites and Center:	High-Frequency driver: 13mm (1/2") Titanium-laminate dome, magnetically shielded. Midrange driver: Dual 89mm (3-1/2"), magnetically shielded
Subwoofer:	70 Watts x 1 @ 1% THD
Transducer Subwoofer:	Low-Frequency driver: 162,5mm (6-1/2")
Signal-to-Noise Ratio:	80 dBA
Input Impedance (analog inputs):	20k Ohms
Input Sensitivity (analog inputs):	400mV
Auto Turn-On Sensitivity (analog inputs):	3mV
Frequency Response (-6 dB):	35Hz – 20kHz





Dimensions (H x W x D)

Satellites (each):	289 x 131 x 86 mm (11-3/8" x 5-5/8" x 3-3/8")
Center:	133 x 289 x 86mm (5-1/4" x 11-3/8" x 3-3/8")
Subwoofer (including feet and connectors):	394 x 273 x 337 mm (15-1/2" x 10-3/4" x 13-1/4")

Weight

Satellites (each):	1,45 kg (3.2 lbs)
Center:	1,45 kg (3.2 lbs)
Subwoofer:	11,8 kg (26 lbs)

OWNER'S GUIDE		JBL	PRO SOUND COMES HOME
PRODUCT LINE: VIRTUAL SURROUND AND STEREO SPEAKERS		JBL Consumer Products 250 Crossways Park Drive, Woodbury, NY 11797 Europe: 2, Route de Tours, 72500 Château du Loir, France www.jbl.com	
MODEL: CS 360 Xcite system		© 2008 Harman International Industries, Incorporated	
DESIGN GOAL: Bring the thrill of live performance and movie sound to the home environment by calling on JBL's professional engineering leadership.		JBL is a registered trademark of Harman International Industries, Incorporated.	
SATELLITE TYPE: Titanium-laminate-dome tweeter, sealed enclosure		Part No. 406-000-05913-E 	
SUBWOOFER TYPE: Bass-reflex enclosure			
PORT DESIGN: FreeFlow™ flared			
PROFESSIONAL REFERENCE: Cinema Loudspeaker Series			

	CAUTION RISK OF ELECTRIC SHOCK DO NOT OPEN	
CAUTION: TO REDUCE THE RISK OF ELECTRIC SHOCK, DO NOT REMOVE COVER (OR BACK). NO USER-SERVICEABLE PARTS INSIDE. REFER SERVICING TO QUALIFIED SERVICE PERSONNEL.		
	The lightning flash with arrowhead symbol, within an equilateral triangle, is intended to alert the user to the presence of uninsulated 'dangerous voltage' within the product's enclosure that may be of sufficient magnitude to constitute a risk of electric shock to persons.	
WARNING: TO REDUCE THE RISK OF FIRE OR ELECTRIC SHOCK, DO NOT EXPOSE THIS APPLIANCE TO RAIN OR MOISTURE.		
The exclamation point within an equilateral triangle is intended to alert the user to the presence of important operating and maintenance (servicing) instructions in the literature accompanying the appliance.		



All features and specifications are subject to change without notice.

All features and specifications are subject to change without notice.

JBL is a trademark of Harman International Industries, Incorporated, registered in the United States and/or other countries.
Pro Sound Comes Home is a trademark of Harman International Industries, Incorporated.

Manufactured under license under U.S. Patent #'s: 5,451,942; 5,956,674; 5,974,380; 5,978,762; 6,487,535; 7,003,467 & other U.S. and worldwide patents issued & pending.
DTS, DTS Digital Surround and Neo:6 are registered trademarks and the DTS logos and Symbol are trademarks of DTS, Inc. © 1996-2008 DTS, Inc. All Rights Reserved

Manufactured under license from Dolby Laboratories.
"Dolby", "Pro Logic", and the double-D symbol are trademarks of Dolby Laboratories.

 and  are trademarks of SRS Labs, Inc.

JBL

PRO SOUND COMES HOME™

Harman Consumer Group, Inc., 250 Crossways Park Drive, Woodbury, NY 11797, USA
8500 Balboa Boulevard, Northridge, CA 91329, USA
2, route de Tours, 72500 Château du Loir, France
516.255.4JBL (4525) (USA only) www.jbl.com
© 2008 Harman International Industries, Incorporated. All rights reserved.
Part No. 406-000-05913-E

H A Harman International Company

Free Manuals Download Website

<http://myh66.com>

<http://usermanuals.us>

<http://www.somanuals.com>

<http://www.4manuals.cc>

<http://www.manual-lib.com>

<http://www.404manual.com>

<http://www.luxmanual.com>

<http://aubethermostatmanual.com>

Golf course search by state

<http://golfingnear.com>

Email search by domain

<http://emailbydomain.com>

Auto manuals search

<http://auto.somanuals.com>

TV manuals search

<http://tv.somanuals.com>