

653.1cs, 1.1cs

INSTRUCTIONS

 Infinity

KAPPASERIES

Thank you for purchasing an Infinity Kappa Series 3-Way Component System. We've organized this manual to make your installation as simple and trouble-free as possible. Please read it thoroughly before proceeding. Remember to keep your sales receipt with this manual in a safe place so both are available for future reference.



IMPORTANT: Installation of automotive stereo components can require extensive experience with a variety of mechanical and electrical procedures. Although these instructions explain how to install a Kappa Series 3-Way Component System in a general sense, they do not show the exact installation methods for your particular vehicle. If you do not feel you have the experience, do not attempt the installation yourself, but instead ask your Authorized Infinity Car Audio Dealer about professional installation options.

WARNING: Playing loud music in an automotive environment can permanently damage your hearing, as well as hinder your ability to hear traffic. The maximum volume levels achievable with Infinity speakers, combined with high power amplification, may exceed safe levels for extended listening. We recommend using low volume levels when driving. Infinity accepts no liability for hearing loss, bodily injury or property damage as a result of use or misuse of this product.

SPEAKER PLACEMENT

Kappa speakers are designed to be easily installed in stock speaker locations. While mounting your speakers in the original factory locations will, in most cases, provide excellent sonic results, the best sounding installations are a result of adherence to a few basic rules:

- For the most spacious stereo image, place the left and right speakers as far apart as possible.
- For enhanced center image, place the left and right speakers so they are equidistant from the listening position. If possible, try to place them as far forward as possible.
- For best treble response aim the tweeters toward the listening position, and be sure there are no obstructions between the tweeters and the listener.

INSTALLATION WARNINGS AND TIPS

- Always wear protective eyewear when using any tools.
- Turn off all audio systems and other electrical devices before you start. Disconnect the (-) negative lead from your vehicle's battery.
- Keep components in their package until final installation. When moving a speaker, always rest it with the cone or dome facing up. Never use force to install any speaker.
- Check clearances on both sides of a planned mounting surface before drilling any holes or installing any screws. Remember that the screws can extend behind the surface.
- At the installation sites, locate and make a note of all fuel lines, hydraulic brake lines, vacuum lines and electrical wiring. Use extreme caution when cutting or drilling in and around these areas.

CAUTION: In some cars, fuel tanks may be located directly beneath the rear deck. Check for adequate speaker basket clearance before considering this location!

- Before drilling or cutting holes, use a utility knife to remove unwanted fabric or vinyl, to keep material from snagging in a drill bit or saw.
- For door installations, check the clearance with the windows throughout the range of the window's travel, and verify that a mounted speaker will not interfere with the window crank or power window mechanism.
- If mounting components elsewhere, check for clearance around rear deck torsion bars, glove box or other structural elements.
- Do not mount components where they will get wet.

WIRE CODES

Single Stereo Amplifier

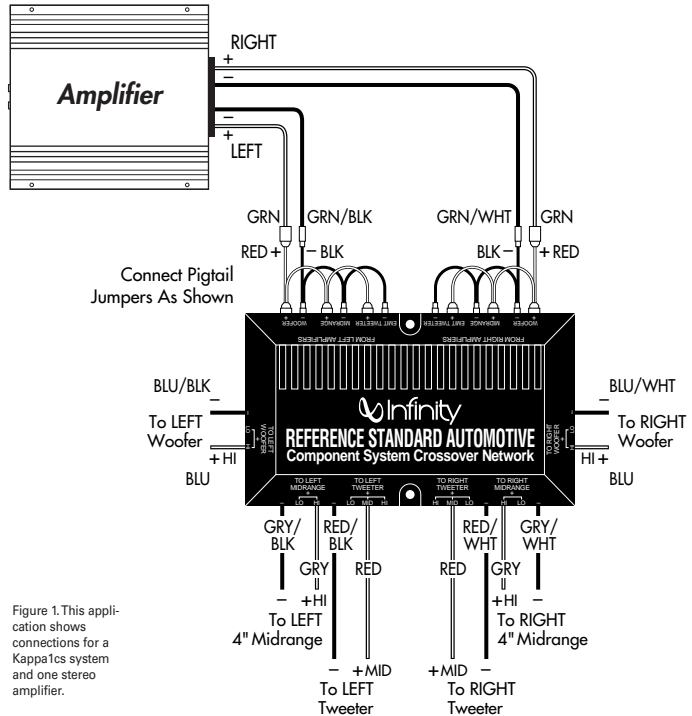

Figure 1. This application shows connections for a Kappa1cs system and one stereo amplifier.

MIDRANGE INSTALLATION

TWEETER INSTALLATION

Bi-Amp

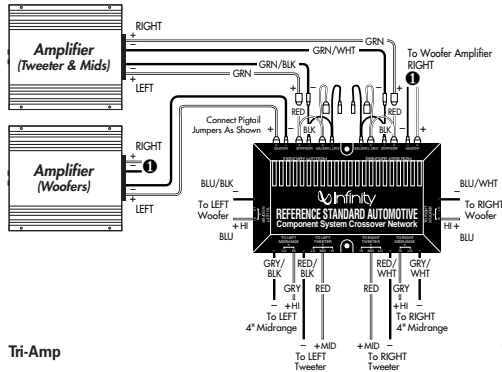

Figure 2. This application shows connections for a Kappa1cs system and two stereo amplifiers.

Tri-Amp

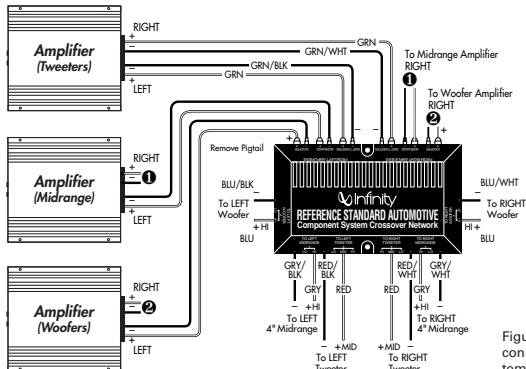

Figure 3. This application shows connections for a Kappa1cs system and three stereo amplifiers.

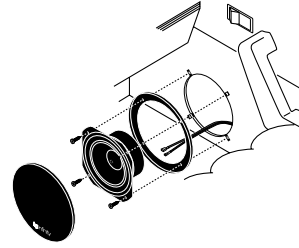

Figure 5. Installing a Kappa 1.1cs/653.1cs midrange driver in a door panel.

WOOFER INSTALLATION

Figure 4. Installing a Kappa 1.1cs/653.1cs woofer above a deck or (with the enclosed spacer) below a deck.

NOTE: Use the mounting clips as nuts to secure the below-deck installation.

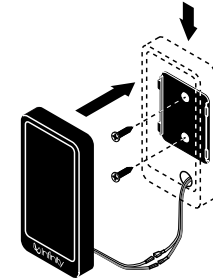
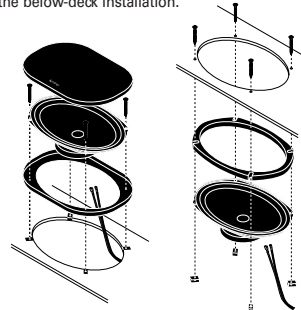

Figure 6. After installing the surface-mount plate, slide the Kappa 1.1cs EMIT-N™ tweeter down on the plate to lock in place.

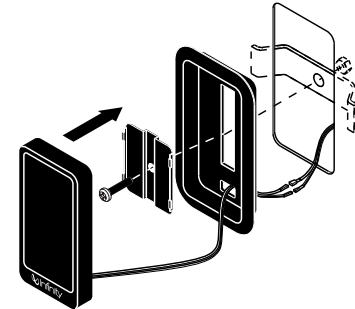

Figure 7. After sliding down the flush-mount clip onto the back of the Kappa 1.1cs EMIT-N tweeter, use the supplied hardware to fasten the cup to the panel.

ADJUSTING THE SOUND

After you have connected all the speakers to the crossover according to the connection diagram, you may adjust the overall sound of the system to suit your taste.

The output of the woofers may be decreased by moving the woofer + connection at the crossover to the low position.

The output of the midrange may be decreased by moving the midrange + connection at the crossover to the low position.

The output of the tweeter may be increased by moving the tweeter + connection at the crossover to the high position or decreased by moving it to the low position.

A NOTE ON POWER HANDLING

The speakers used in Kappa Series 3-Way Component Systems are designed to produce reasonable volume levels with little amplifier power. However, the addition of an amplifier to drive your speakers and a subwoofer will enhance the dynamic range of your system, and help overcome the ambient noise in a moving vehicle. Kappa speakers are designed to handle the power of a dedicated amplifier driven at or below its rated power. If an amplifier is driven far above its rated power, the output signal will "clip," and the additional power present in a clipped signal can damage any speaker. Distorted or "fuzzy" sound from your speakers is an indication that the amplifier has exceeded its rated power, and you should reduce the volume level.

GENERAL CARE

The loudspeaker grilles may be cleaned with a slightly damp cloth. Do not use any cleaners or solvents on the grilles or the speaker cones.

SPECIFICATIONS

653.1cs

Type: 6-1/2" 3-Way System
Speaker Impedance: 4 ohms
Power Handling: 120 watts per channel
Frequency Response (±3dB): 50Hz ~ 45kHz
Sensitivity: 89Hz @ 2.83 V, 1 watt
Crossover Frequencies: Woofer
Hi terminal: 210Hz
Lo terminal: 130Hz
Midrange: 400Hz
Tweeter: 12.5kHz

Mounting Depth,
Drop-in Woofer: 2-1/2" (675 mm)
Cut-out
Diameter Woofer: 5-11/16" (149 mm)
Mounting Depth,
Drop-in Midrange: 1-13/16" (46 mm)
Cut-out
Diameter Midrange: 3-3/4" (96 mm)
Mounting
Depth Tweeter: 1" (25.4 mm)
Cut-out
Diameter Tweeter: 3-3/8" x 1-3/4"
(84.6 mm x 44.7 mm)

1.1cs

Type: 6" x 9" 3-Way System
Speaker Impedance: 4 ohms
Power Handling: 200 watts per channel
Frequency Response (±3dB): 36Hz ~ 45kHz
Sensitivity: 89Hz @ 2.83 V, 1 watt
Crossover Frequencies: Woofer
Hi terminal: 210Hz
Lo terminal: 130Hz
Midrange: 400Hz
Tweeter: 12.5kHz

Mounting Depth
Drop-in Woofer: 2-9/16" (65 mm)
Cut-out
Diameter Woofer: 5-11/16" x 8-3/4"
(149 mm x 223 mm)
Mounting Depth,
Drop-in Midrange: 1-13/16" (46 mm)
Cut-out
Diameter Midrange: 3-3/4" (96 mm)
Mounting
Depth Tweeter: 1" (25.4 mm)
Cut-out
Diameter Tweeter: 3-3/8" x 1-3/4"
(84.6 mm x 44.7 mm)

DECLARATION OF CONFORMITY



We, Infinity Systems AS
Kongevejen 194B
DK-3460 Birkerød
DENMARK

declare in own responsibility, that the products described in this owner's manual are in compliance with technical standards:
EN 50 081-1/1992
EN 50 082-1/0.1995

Steen Michaelsen
Infinity Systems AS
Birkerød, DENMARK 2/88



Infinity Systems, Inc. • 250 Crossways Park Drive,
Woodbury, NY 11797 USA • (516) 496-3400 • FAX (516) 682-3583

Free Manuals Download Website

<http://myh66.com>

<http://usermanuals.us>

<http://www.somanuals.com>

<http://www.4manuals.cc>

<http://www.manual-lib.com>

<http://www.404manual.com>

<http://www.luxmanual.com>

<http://aubethermostatmanual.com>

Golf course search by state

<http://golfingnear.com>

Email search by domain

<http://emailbydomain.com>

Auto manuals search

<http://auto.somanuals.com>

TV manuals search

<http://tv.somanuals.com>