

CASCADE™

SERIES



INFINITY CASCADE™ SPEAKER SYSTEMS

Owner's Guide

Model Five

Model Seven

Model Nine

Model Three V

Model Three C



INFINITY CASCADE™ SERIES

The Infinity Cascade Series of loudspeakers continues Infinity's long-standing commitment to accurate sound reproduction. Our patent-pending Maximum Radiating Surface™ (MRS™) technology, patented Ceramic Metal Matrix Diaphragm (CMMD®) drivers, precision dividing networks and rigid, well-braced enclosures, along with our newly developed, patent-pending Constant Acoustic Impedance™ (CAI™) waveguide, combine to deliver uncompromised performance in any stereo or multichannel home theater system. In addition, Cascade Series speakers are magnetically shielded for safe placement adjacent to a television.

UNPACKING THE SPEAKERS

If you suspect damage from transit, report it immediately to your dealer. Keep the shipping carton and packing materials for future use.

WHAT'S INCLUDED

Model Nine

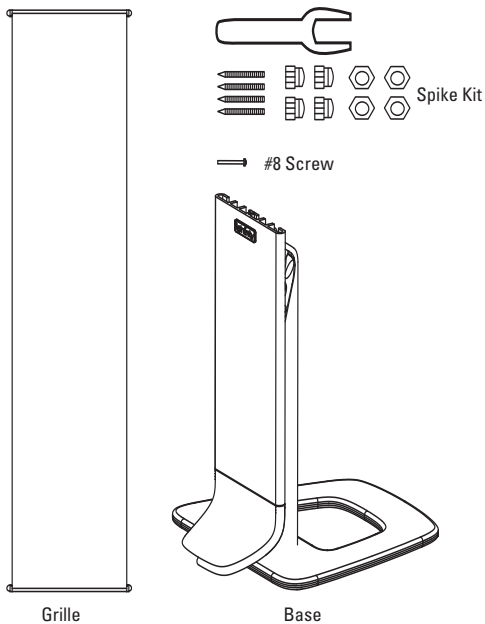

Model Five

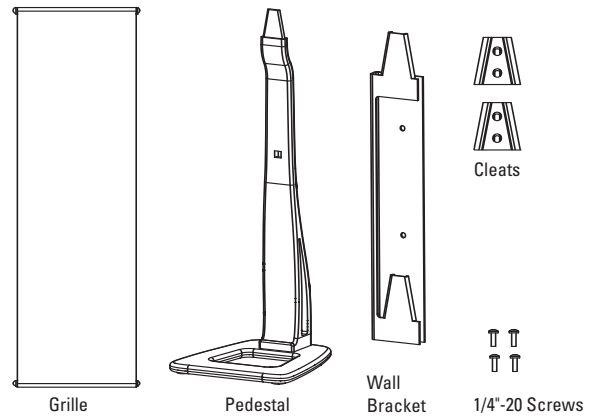

Model Three V

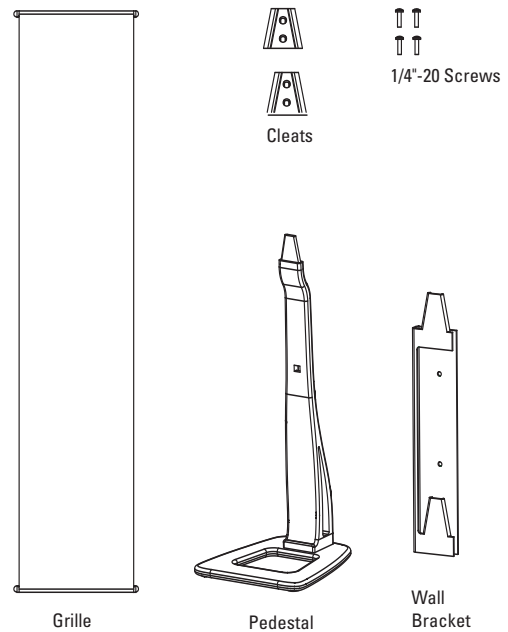

Model Seven

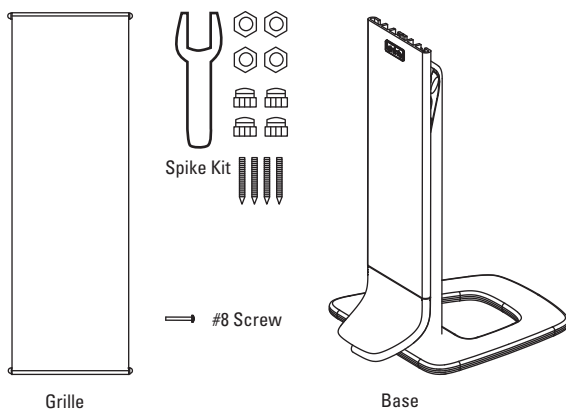

Model Three C

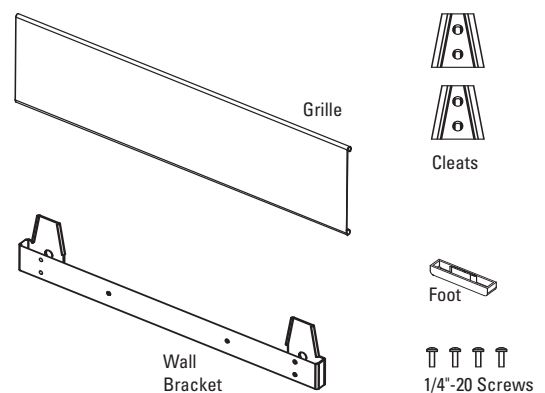

PLACEMENT

Stereo

Before deciding where to place your Cascade speakers, survey your room and think about placement, keeping the following points in mind and using Figure 1 as a guide:

- For best results, place the speakers 6' – 8' (1.5m – 2.5m) apart.
- Position each speaker so that the tweeter is approximately at ear level.
- Generally, bass output will increase as the speaker is moved closer to a wall or corner.
- Refer to "Home Theater" if you also plan to use the speakers for home theater reproduction.

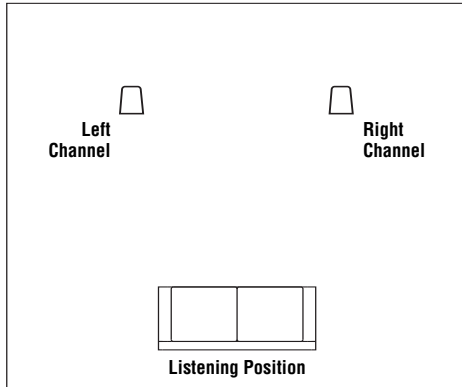

Figure 1. Experiment with speaker placement to obtain the best bass level and stereo imaging in your room.

Home Theater

For front-channel use, place one speaker on the left and another on the right, along either side of the television monitor. Since the speakers are magnetically shielded, you can place them near the TV without worrying about the magnetic field distorting the TV picture.

For surround-channel use, place speakers on bookshelves or stands alongside the listening position. Final placement depends on room acoustics, availability of space and your listening preference (Figures 2 and 3).

In 6- or 7-channel configurations, place the rear channel(s) behind the listening position, as shown in Figures 2 and 3.

NOTE: An Infinity powered subwoofer will add impact and realism to both music and film soundtracks. Contact your Infinity dealer for recommendations on subwoofer models for your application.

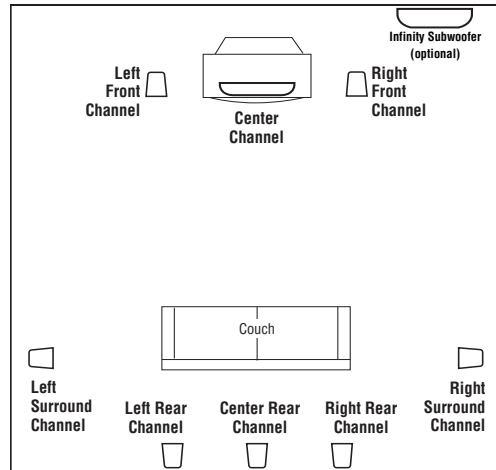

Figure 2. This overhead view shows a typical home theater plan. Left/right rear channels are for a 7-channel system. Center rear channel is for a 6-channel system.

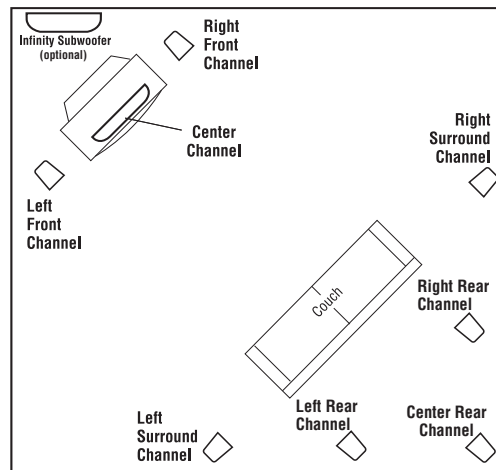

Figure 3. This figure shows an alternate layout, which may be more suitable for some rooms. Left/right rear channels are for a 7-channel system. Center rear channel is for a 6-channel system.

ASSEMBLY

It is strongly recommended that two people assemble the speakers to minimize the possibility of damage or injury.

Installing Spiked Feet (Model Nine and Model Seven)

1. Open spike kit and locate the following items: feet (with spike/round ends), four locking nuts, four nylon domes and one wrench.
2. Lay each stand on its side and locate the four threaded holes on the bottom of the base.
3. For carpets, screw the round end of a foot into each hole and fully hand-tighten a nut onto each one. For hard-surface floors, screw the spike end into each hole instead and leave the rounded end exposed.
4. Carefully flip each base upright to sit on its feet.
5. If needed, adjust the feet so each speaker is level and then tighten each nut with the enclosed wrench. To protect hard surfaces (e.g., wood floors), slip a nylon dome onto each round end.

Note: Spiked feet must be fully threaded into holes provided in the base to ensure stability.

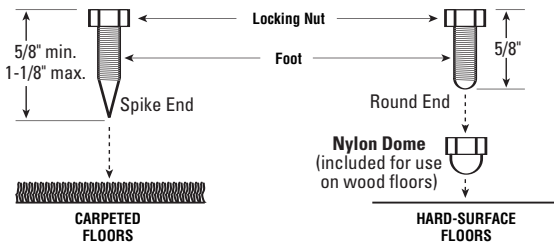

This cross section shows how to install the spikes onto the bottom of a Cascade Model Nine and Model Seven.

Model Nine and Model Seven

1. Remove floor stand from carton.
2. Slide loud-speaker onto stand, making sure the aligning posts are lined up with the receiver terminal cup.
3. Insert #8 pan-head screw into rear of speaker to secure to stand.

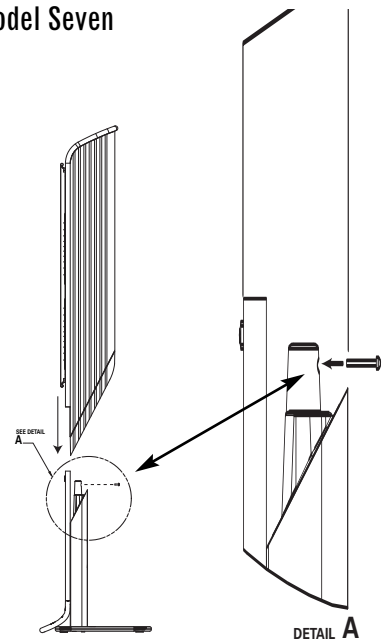

Model Three V

1. Remove base from carton.
2. Securely fasten one cleat to the middle set of holes on the rear of the speaker using two included 1/4"-20 panhead screws.
3. Slide speaker with cleat over the base.

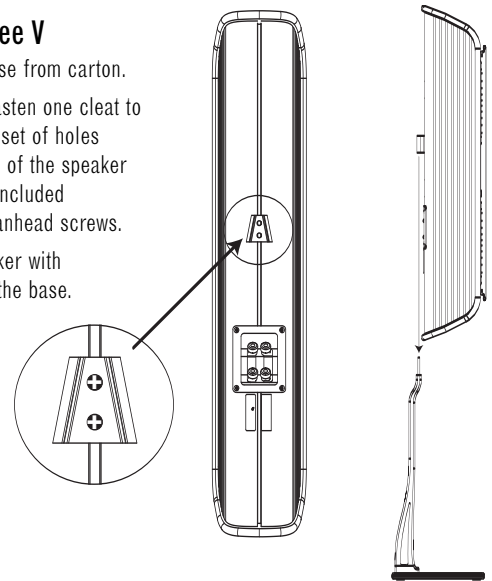

Model Five

1. Remove base from carton.
2. Securely fasten one cleat to the set of holes above the terminal using two included 1/4"-20 panhead screws.
3. Slide speaker with cleat over the base.

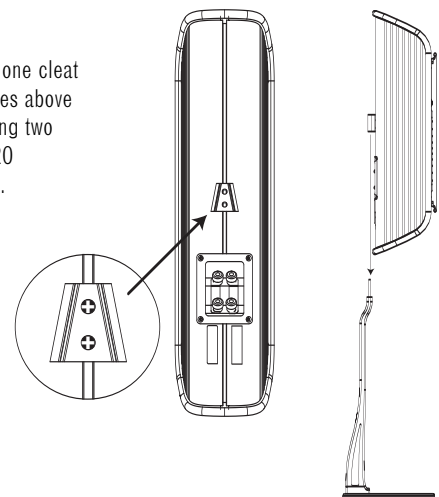

WALL-MOUNTING

NOTE: The customer is responsible for the correct selection and use of mounting hardware (available through hardware stores) that will ensure the proper and safe wall-mounting of the speakers.

Model Three V, Model Three C, Model Five

1. Attach wall bracket to wall at desired location.

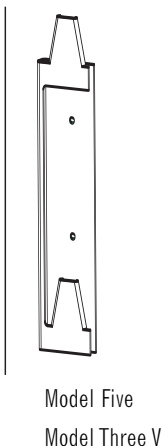
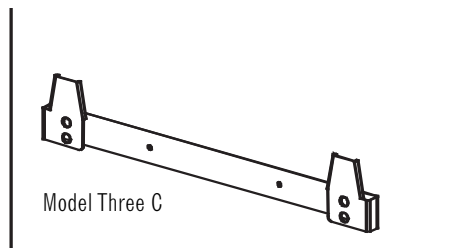

2. Securely fasten the two cleats to the rear of the speaker, using the outermost holes, using two included 1/4"-20 panhead screws per cleat.

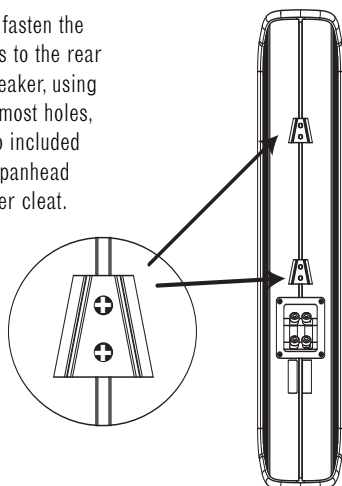

3. Carefully slide the cleats on the rear of the speakers over the tabs of the wall bracket.

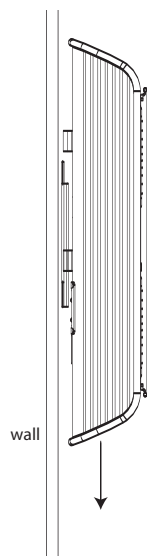

Attaching the Grilles

The Cascade loudspeakers use a unique frameless grille. Each end of the grille cloth contains a magnet. Simply curl the magnet assembly behind the grille cloth, place one end of the grille just above the tweeter and then gently pull the grille taut, attaching the other end of the grille just below the woofer.

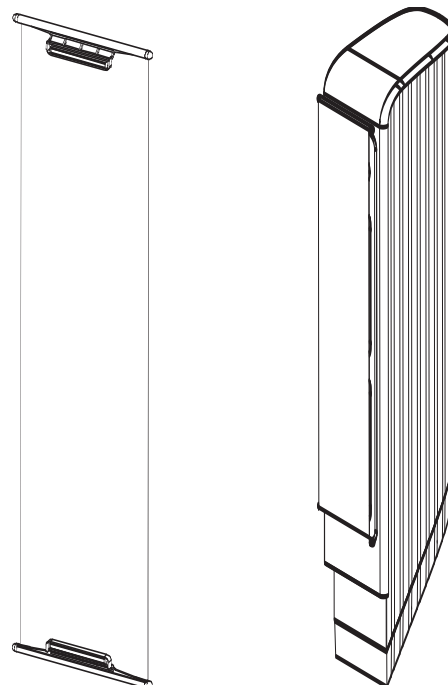

WIRING THE SYSTEM

IMPORTANT: Make sure all equipment is turned off before making any connections.

For speaker connections, use a high-quality speaker wire with polarity coding. The side of the wire with a ridge or other coding is usually considered positive polarity (i.e., +).

NOTE: If desired, consult your local Infinity dealer about speaker wire and connection options.

To ensure proper polarity, connect each + terminal on the back of the amplifier or receiver to the respective + (red) terminal on each speaker, as shown in Figure 4. Connect the - (black) terminals in a similar way. See the owner's guides that were included with your amplifier or receiver and television to confirm connection procedures.

IMPORTANT: Do not reverse polarities (i.e., + to - or - to +) when making connections. Doing so will cause poor imaging and diminished bass response.

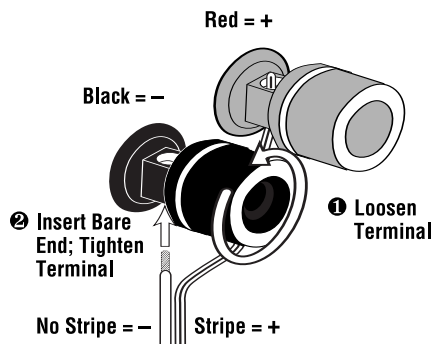

Figure 4. This figure shows how to connect bare wires to the terminals.

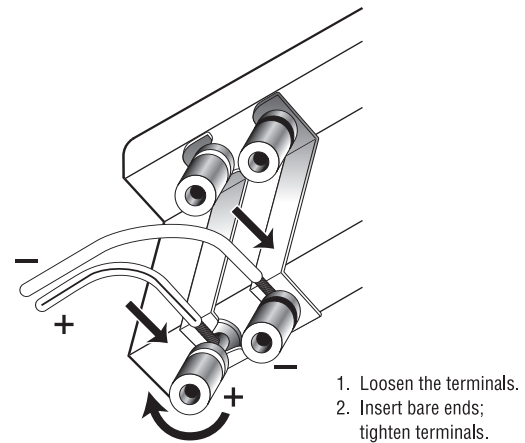

Figure 5. This example shows how to connect bare wires to the terminals. Banana plugs may also be inserted directly into the rear of the connector.

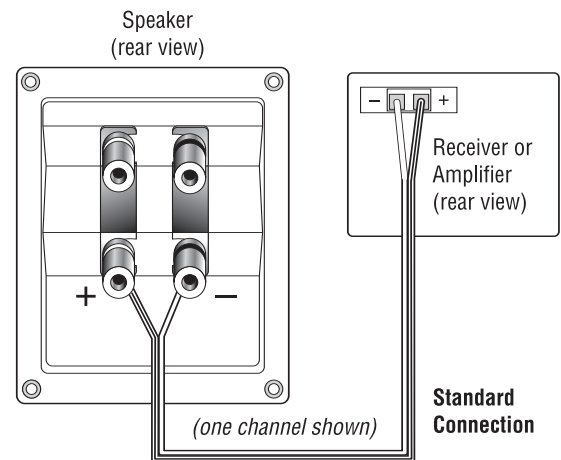

Figure 6. Wiring diagram shows polarity connections for one channel of a stereo or home theater system.

BI-WIRING

The outer connection panel and internal dividing network of the Cascade loudspeakers are designed so that separate sets of speaker cables can be attached to the low-frequency transducer and midrange/high-frequency transducer portions of this dividing network. This is called bi-wiring. Bi-wiring can provide several sonic advantages and considerably more flexibility in power amplifier selection.

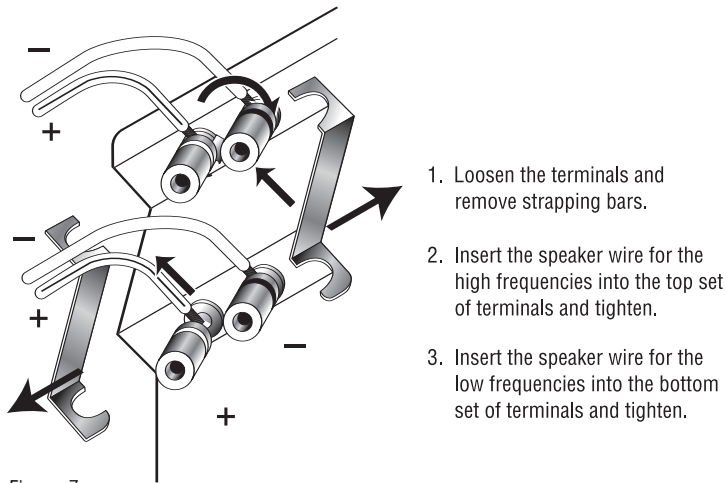

Figure 7.

1. Loosen the terminals and remove strapping bars.
2. Insert the speaker wire for the high frequencies into the top set of terminals and tighten.
3. Insert the speaker wire for the low frequencies into the bottom set of terminals and tighten.

Single-Stereo Amplifier

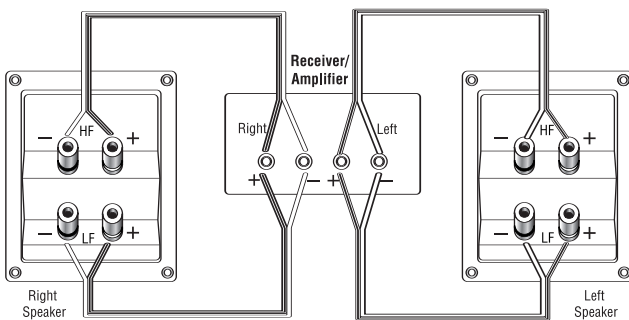

Figure 8.

Dual-Stereo Amplifier

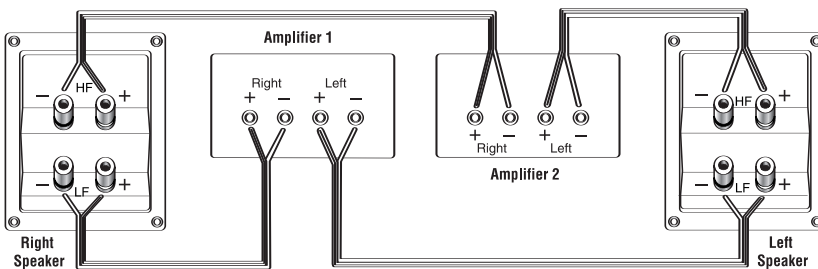

Figure 9.

FINAL ADJUSTMENTS

Check the speakers for playback, first by setting the system volume control to a minimum level, and then by turning on the power of your audio system. Play a favorite music or video segment and increase the system volume control to a comfortable level.

NOTE: You should hear balanced audio reproduction across the entire frequency spectrum. If not, check all wiring connections or consult the authorized Infinity dealer from whom you purchased the system.

The amount of bass you hear and the stereo-image quality will be affected by a number of different factors, including the room's size and shape, the construction materials used to build the room, the listener's position relative to the speakers, and the position of the speakers in the room.

Listen to a variety of music selections and note the bass level. If there is too much bass, move the speakers away from nearby walls. Conversely, if you place the speakers closer to the walls, there will be more bass output.

Nearby reflecting surfaces can adversely affect stereo-imaging quality. If this happens, try angling the speakers slightly inward toward the listening position until the optimum effect is achieved.

CARE OF YOUR SPEAKER SYSTEM

Each Cascade Series enclosure has a finish that does not require any routine maintenance. When needed, use a soft cloth to remove any fingerprints or dust from the enclosure.

NOTE: Do not use any cleaning products or polishes on the cabinet or grille.

If a problem occurs, make sure that all connections are properly made and clean. If a problem exists in one loudspeaker, reverse the connection wires to the left and right system. If the problem remains in the same speaker, then the fault is with the loudspeaker. If the problem appears in the opposite speaker, the cause is in another component or cable. In the event that your subwoofer ever needs service, contact your local Infinity dealer or distributor, or go to www.infinitysystems.com to locate a service center near you.

IMPORTANT: Please attach your sales receipt to this manual and store it in a safe place. In the event that your Infinity speaker requires warranty service, you will need to provide your sales receipt.

SPECIFICATIONS

	Model Nine	Model Seven	Model Five
Frequency Response:	80Hz – 20kHz (±3dB) 40kHz (–6dB)	100Hz – 20kHz (±3dB) 40kHz (–6dB)	100Hz – 20kHz (±3dB) 40kHz (–6dB)
Recommended Amplifier Power Range:	10 – 150 Watts	10 – 100 Watts	10 – 150 Watts
Sensitivity: (2.83V @ 1 meter)	87dB	85dB	85dB
Nominal Impedance:	8 Ohms	8 Ohms	8 Ohms
Crossover Frequency:	1,500Hz; 24dB/octave	1,800Hz; 24dB/octave	1,800Hz; 12dB/octave
Mid-Bass Driver(s):	Dual 7-3/4" x 3-3/8" (197mm x 85mm) CMMD®, magnetically shielded	7-3/4" x 3-3/8" (197mm x 85mm) CMMD®, magnetically shielded	7-3/4" x 3-3/8" (197mm x 85mm) CMMD®, magnetically shielded
High-Frequency Driver:	1" (25mm) CMMD, magnetically shielded	1" (25mm) CMMD, magnetically shielded	1" (25mm) CMMD, magnetically shielded
Dimensions (H x W x D): (with grille)	47" x 10-1/2" x 11-1/2" (1194mm x 267mm x 292mm)	47" x 10-1/2" x 11-1/2" (1194mm x 267mm x 292mm)	22-1/2" x 5-1/2" x 5-1/2" (572mm x 140mm x 140mm) Wall-mounted 30-1/4" x 7-3/4" x 8-1/2" (768mm x 197mm x 216mm) On included base
Weight:	28.2 lb (12.8kg)	24.7 lb (11.2kg)	13.5 lb (6.1kg) Wall-mounted 20.5 lb (9.3kg) On included base
	Model Three V	Model Three C	
Frequency Response:	80Hz – 20kHz (±3dB) 40kHz (–6dB)	80Hz – 20kHz (±3dB) 40kHz (–6dB)	
Recommended Amplifier Power Range:	NA	10 – 150 Watts	
Sensitivity: (2.83V @ 1 meter)	87dB	87dB	
Nominal Impedance:	8 Ohms	8 Ohms	
Crossover Frequency:	1,500Hz; 24dB/octave	1,500kHz; 24dB/octave	
Mid-Bass Driver(s):	Dual 7-3/4" x 3-3/8" (197mm x 85mm) CMMD®, magnetically shielded	Dual 7-3/4" x 3-3/8" (197mm x 85mm) CMMD®, magnetically shielded	
High-Frequency Driver:	1" (25mm) CMMD, magnetically shielded	1" (25mm) CMMD, magnetically shielded	
Dimensions (H x W x D): (with grille)	30" x 5-1/2" x 5-1/2" (762mm x 140mm 140mm) Wall-mounted 36-5/8" x 7-3/4" x 8-1/2" (930mm x 197mm x 216mm) On included base	5-1/2" x 30-3/4" x 6" (140mm x 781mm x 152mm)	
Weight:	18 lb (8.2kg) Wall-mounted 26 lb (11.8kg) On included base	18 lb (8.2kg)	

Infinity continually strives to update and improve existing products, as well as create new ones. The specifications and construction details in this and related Infinity publications are therefore subject to change without notice.



TECHNOLOGY • PERFORMANCE • DESIGN

© 2005 Harman International Industries, Incorporated. All rights reserved.

Infinity Systems, 250 Crossways Park Drive, Woodbury, NY 11797 USA 516.674.4INF (4463) (USA only) www.infinitysystems.com

Infinity, Harman International and CMMD (patent nos. 6,327,372 and 6,404,897) are trademarks of Harman International Industries, Incorporated, registered in the United States and/or other countries.

Cascade, Maximum Radiating Surface and Constant Acoustic Impedance (patent pending) are trademarks of Harman International Industries, Incorporated.

Part No. 819001082001 8/05

H A Harman International® Company



Free Manuals Download Website

<http://myh66.com>

<http://usermanuals.us>

<http://www.somanuals.com>

<http://www.4manuals.cc>

<http://www.manual-lib.com>

<http://www.404manual.com>

<http://www.luxmanual.com>

<http://aubethermostatmanual.com>

Golf course search by state

<http://golfingnear.com>

Email search by domain

<http://emailbydomain.com>

Auto manuals search

<http://auto.somanuals.com>

TV manuals search

<http://tv.somanuals.com>