

Visit www.carrier.com

Installation and Start-Up Instructions

NOTE: Read the entire instruction manual before beginning the installation.

This symbol → indicates a change since last issue.

SAFETY CONSIDERATIONS

Improper installation, adjustment, alteration, service, maintenance, or use can cause explosion, fire, electrical shock, or other conditions which may cause personal injury or property damage. Consult a qualified installer, service agency, or your distributor or branch for information or assistance. The qualified installer or agency must use factory-authorized kits or accessories when modifying this product. Refer to the individual instructions packaged with the kits or accessories when installing.

Follow all safety codes. Wear safety glasses and work gloves. Use quenching cloth for brazing operations. Have fire extinguisher available. Read these instructions thoroughly and follow all warning or cautions attached to the unit. Consult local building codes and National Electrical Code (NEC) for special requirements.

Recognize safety information. This is the safety-alert symbol ⚠. When you see this symbol on the unit and in instructions or manuals, be alert to the potential for personal injury.

Understand these signal words: DANGER, WARNING, and CAUTION. These words are used with the safety-alert symbol. DANGER identifies the most serious hazards which **will** result in severe personal injury or death. WARNING signifies hazards which **could** result in personal injury or death. CAUTION is used to identify unsafe practices which **would** result in minor personal injury or product and property damage.

⚠ WARNING

Before installing, modifying, or servicing system, main electrical disconnect switch must be in the OFF position. There may be more than 1 disconnect switch. Lock out and tag switch with a suitable warning label. Electrical shock can cause personal injury or death.

INSTALLATION RECOMMENDATIONS

NOTE: In some cases, noise in the living area has been traced to gas pulsations from improper installation of equipment.

1. Locate the unit away from windows.
2. Ensure that vapor and liquid line diameters are appropriate to the capacity of the unit. (See Table 1.)
3. Run refrigerant tubes as directly as possible by avoiding unnecessary turns and bends.
4. Leave some slack between the structure and the unit to absorb vibration.

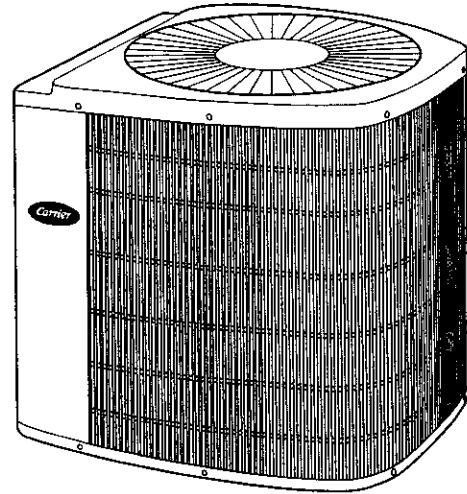

A98519



Fig. 1—Model 38TKB

5. When passing refrigerant tubes through the wall, seal the opening with RTV or other pliable silicon-based caulk. (See Fig. 3.)
6. Avoid direct lineset contact with water pipes, ductwork, floor joists, wall studs, floors, and walls.
7. Do not suspend refrigerant tubing from joists and studs with a rigid wire or strap which comes in direct contact with the tubing. (See Fig. 3.)
8. Ensure that tubing insulation is pliable and completely surrounds the vapor line.
9. When necessary, use hanger straps which are 1 in. wide and conform to the shape of the tubing insulation. (See Fig. 3.)
10. Isolate the hanger straps from the insulation by using metal sleeves bent to conform to the shape of the insulation.

When outdoor unit is connected to factory-approved indoor unit, outdoor unit contains system refrigerant charge for operation with factory-approved indoor unit of the same size when connected by 15 ft of field-supplied tubing. For proper unit operation, check refrigerant charge using charging information located on control box cover.

IMPORTANT: Maximum liquid-line size is 3/8-in. O.D. for all residential applications including long line.

IMPORTANT: Always install a liquid-line filter drier. Refer to Product Data Digest for appropriate part number. Obtain filter driers from your local distributor or branch.

Manufacturer reserves the right to discontinue, or change at any time, specifications or designs without notice and without incurring obligations.

Table 1—Refrigerant Connections and Recommended Liquid and Vapor Tube Diameters (In.)

UNIT SIZE	LIQUID		VAPOR		VAPOR (LONG LINE)	
	Connection Diameter	Tube Diameter	Connection Diameter	Tube Diameter	Connection Diameter	Tube Diameter
018, 024	3/8	3/8	5/8	5/8	5/8	3/4
030, 036	3/8	3/8	3/4	3/4	3/4	7/8
042, 048	3/8	3/8	7/8	7/8	7/8	1-1/8
060	3/8	3/8	7/8	1-1/8	7/8	1-1/8

Notes: 1. Tube diameters are for lengths up to 50 ft. For tube sets over 50 ft. consult Residential Long-Line Application Guideline.
2. Do not apply capillary tube indoor coils to these units.

INSTALLATION

Step 1—Check Equipment and Job Site

UNPACK UNIT — Move to final location. Remove carton taking care not to damage unit.

INSPECT EQUIPMENT — File claim with shipping company prior to installation if shipment is damaged or incomplete. Locate unit rating plate on unit service panel. (See Fig. 2.) It contains information needed to properly install unit. Check rating plate to be sure unit matches job specifications.

Step 2—Install on a Solid, Level Mounting Pad

If conditions or local codes require the unit be attached to a pad, tie down bolts should be used and fastened through knockouts

provided in unit base pan. Refer to unit mounting pattern shown in Fig. 2 to determine base pan size and knockout hole location.

On rooftop applications, mount on level platform or frame. Place unit above a load-bearing wall and isolate unit and tubing set from structure. Arrange supporting members to adequately support unit and minimize transmission of vibration to building. Consult local codes governing rooftop applications.

Roof mounted units exposed to winds above 5 mph may require wind baffles. Consult Low-Ambient Guideline for wind baffle construction.

NOTE: Unit must be level to within $\pm 2^\circ$ per compressor manufacturer specifications.

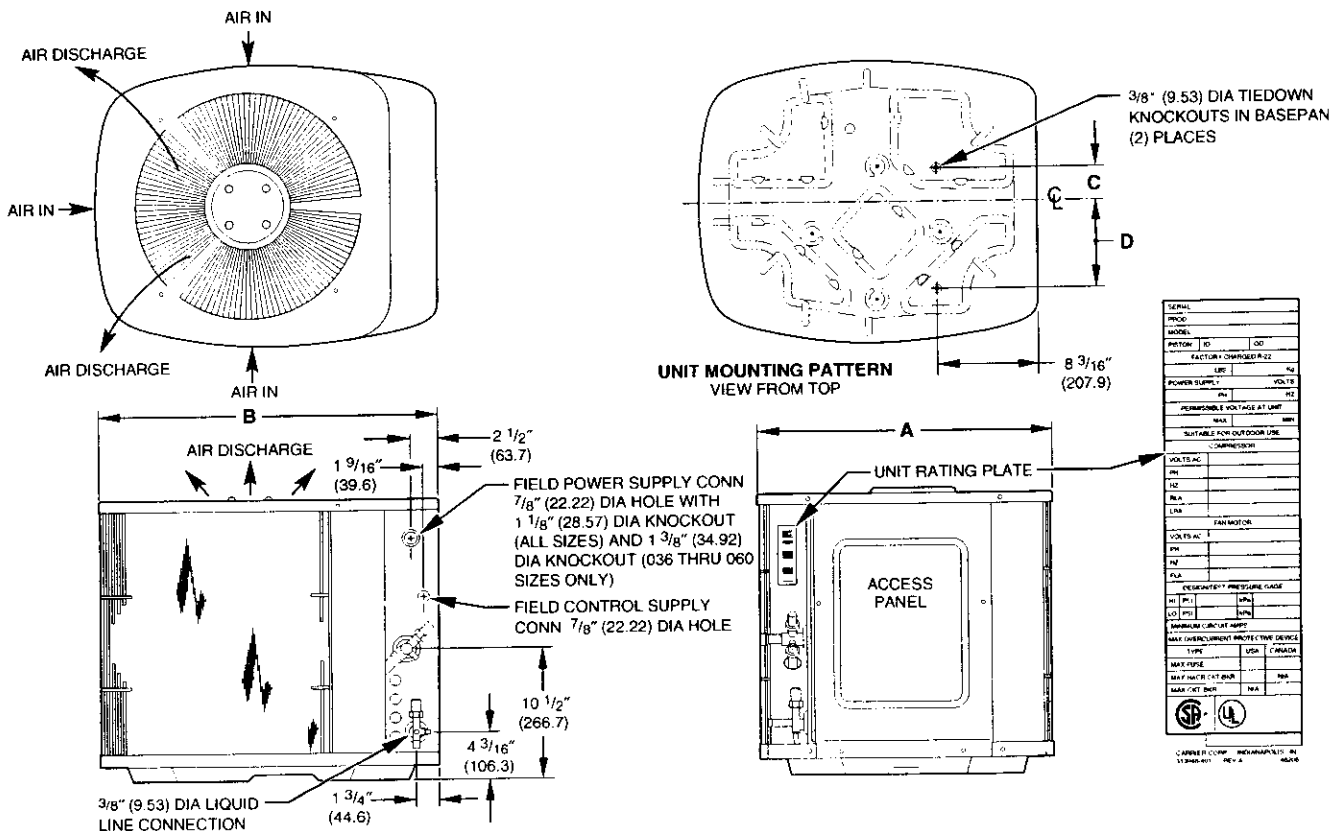

- NOTES:
1. ALLOW 30" (762) CLEARANCE TO SERVICE END OF UNIT, 48" (1219) ABOVE UNIT, 6" (152) ON ONE SIDE, 12" (306) ON REMAINING SIDE, AND 24" (610) BETWEEN UNITS FOR PROPER AIRFLOW.
 2. MINIMUM OUTDOOR OPERATING AMBIENT IN COOLING MODE IS 55°F (12.8°C), (UNLESS LOW AMBIENT CONTROL IS USED) MAX 125°F (51.7°C).
 3. MAXIMUM OUTDOOR OPERATING AMBIENT IN HEATING MODE IS 66°F (18.9°C).
 4. DIMENSIONS IN PARENTHESIS ARE IN MILLIMETERS.
 5. SERIES DESIGNATION IS THE 13TH POSITION OF THE UNIT MODEL NUMBER.

A91055

MODEL 38TKB	A	B	C	D
	In.	In.	In.	In.
018, 024, 030, 036	22-1/2	27-1/2	2-13/16	6-15/16
042, 048, 060	30	34-15/16	4	9-3/4

Fig. 2—Unit Reference Drawing

NOTE: Avoid contact between tubing and structure

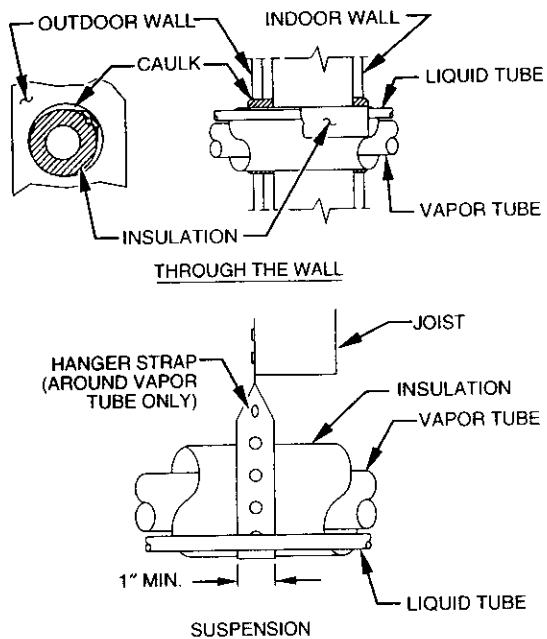

Fig. 3—Piping Installation

A94028

Step 3—Clearance Requirements

When installing, allow sufficient space for airflow, wiring, refrigerant piping, and service. Allow 30 in. clearance to service end of unit and 48 in. above unit. For proper airflow, a 6 in. clearance on 1 side of unit and 12 in. on all remaining sides must be maintained. Maintain a distance of 24 in. between units. Position so water, snow, or ice from roof or eaves cannot fall directly on unit.

On rooftop applications, locate unit at least 6 in. above roof surface.

Step 4—Operating Ambients

The minimum outdoor operating ambient in cooling mode is 55°F, and the maximum outdoor operating ambient in cooling mode is 125°F.

Step 5—Replace Indoor AccuRater® Piston, if Required

Check indoor coil piston to see if it matches the required piston shown on unit rating plate. If it does not match, replace indoor coil piston with piston shipped with this unit. The piston shipped with outdoor unit is correct for any approved indoor coil combination.

⚠ CAUTION

Remove indoor coil piston if unit is to be installed on system with a thermostatic expansion valve (TXV) metering device.

Step 6—Make Tubing Connections

⚠ WARNING

Relieve pressure and recover all refrigerant before system repair or final unit disposal to avoid personal injury or death. Use all service ports and open all flow-control devices, including solenoid valves.

⚠ CAUTION

→ If ANY refrigerant tubing is buried, provide a 6 in. vertical rise at service valve. Refrigerant tubing lengths up to 36 in. may be buried without further special consideration. For lengths above 36 in., consult your local distributor.

⚠ CAUTION

To prevent damage to unit or service valves observe the following:

- Use a brazing shield.
- Wrap service valves with wet cloth or use a heat sink material.

Outdoor units may be connected to indoor section using accessory tubing package or field-supplied refrigerant tubing of correct size and condition. For tubing requirements beyond 50 ft, substantial capacity and performance losses can occur. Following the recommendations in the Residential Split System Long-Line Application Guideline will reduce these losses. Refer to Table 1 for field tubing equivalent line length. Refer to Table 2 for accessory requirements.

→ For buried-line applications greater than 36 in., consult your local distributor.

If refrigerant tubes or indoor coil are exposed to atmosphere, they must be evacuated to 500 microns to eliminate contamination and moisture in the system.

OUTDOOR UNIT CONNECTED TO FACTORY-APPROVED INDOOR UNIT — Outdoor unit contains correct system refrigerant charge for operation with indoor unit of same size when connected by 15 ft of field-supplied or factory-accessory tubing. Check refrigerant charge for maximum efficiency.

REFRIGERANT TUBING — Connect tubing to fittings on outdoor unit vapor and liquid service valves. (See Table 1.) Use refrigerant grade tubing.

SWEAT CONNECTION — Service valves are closed from factory and ready for brazing. After wrapping the service valve with a wet cloth, the tubing set can be brazed to the service valve using either silver bearing or non-silver bearing brazing material. Consult local code requirements. Refrigerant tubing and indoor coil are now ready for leak testing. This check should include all field and factory joints.

⚠ CAUTION

To avoid valve damage while brazing, service valves must be wrapped in a heat-sinking material such as a wet cloth.

Step 7—Make Electrical Connections

Be sure field wiring complies with local and national fire, safety, and electrical codes, and voltage to system is within limits shown on unit rating plate. Contact local power company for correction of improper voltage. See unit rating plate for recommended circuit protection device.

NOTE: Operation of unit on improper line voltage constitutes abuse and could affect unit reliability. See unit rating plate. Do not install unit in system where voltage or phase imbalance may fluctuate above or below permissible limits.

NOTE: Use copper wire only between disconnect switch and unit.

Table 2—Accessory Usage

ACCESSORY	REQUIRED FOR LOW-AMBIENT APPLICATIONS (BELOW 55°F)	REQUIRED FOR LONG-LINE APPLICATIONS* (OVER 50 FT)	REQUIRED FOR SEA COAST APPLICATIONS (WITHIN 2 MILES)
Crankcase Heater	Yes	Yes	No
Evaporator Freeze Thermostat	Yes	No	No
Winter Start Control	Yes†	No	No
Accumulator	No	No	No
Compressor Start Assist Capacitor and Relay	Yes	Yes	No
Low-Ambient Controller, MotorMaster® Control, or Low-Ambient Pressure Switch	Yes	No	No
Wind Baffle	See Low-Ambient Instructions	No	No
Coastal Filter	No	No	Yes
Support Feet	Recommended	No	Recommended
Liquid-Line Solenoid Valve or Hard Shutoff TXV	No	See Long-Line Application Guideline	No
Ball Bearing Fan Motor	Yes‡	No	No

* For tubing line sets between 50 and 175 ft, refer to Residential Split System Long-Line Application Guideline.

† Only when low-pressure switch is used.

‡ Required for Low-Ambient Controller (full modulation feature) and MotorMaster Control only.

⚠ WARNING

To avoid personal injury or death, do not supply power to unit with compressor terminal box cover removed.

NOTE: Install branch circuit of adequate size per NEC to handle unit starting current. Locate disconnect within sight from and readily accessible from unit per Section 440-14 of NEC.

⚠ WARNING

The unit cabinet must have an uninterrupted or unbroken ground to minimize personal injury if an electrical fault should occur. The ground may consist of electrical wire or metal conduit when installed in accordance with existing electrical codes. Failure to follow this warning can result in an electrical shock, fire, or death.

ROUTE GROUND AND POWER WIRES — Remove access panel and control box cover to gain access to unit wiring. Extend wires from disconnect through power wiring hole provided and into unit control box.

DISCONNECT
PER N. E. C. AND/OR
LOCAL CODES

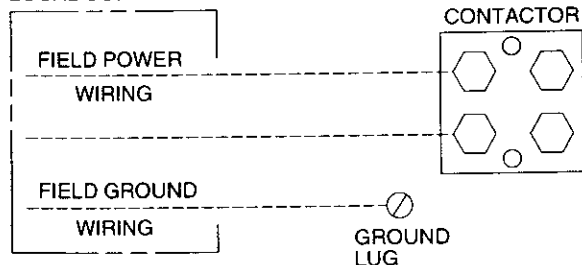

A91056

Fig. 4—Line Power Connections

CONNECT GROUND AND POWER WIRES — Connect ground wire to ground connection in control box for safety. Connect power wiring to contactor as shown in Fig. 4.

CONNECT CONTROL WIRING — Route 24-v control wires through control wiring grommet and connect leads to control wiring. (See Fig. 5.)

Use No. 18 AWG color-coded, insulated (35° C minimum) wire. If thermostat is located more than 100 ft from unit as measured along the control voltage wires, use No. 16 AWG color-coded wires to avoid excessive voltage drop.

All wiring must be NEC Class 1 and must be separated from incoming power leads.

Use furnace transformer, fan-coil transformer, or accessory transformer for control power, 24-v/40va minimum.

NOTE: Use of available 24-v accessories may exceed the minimum 40-va power requirement. Determine total transformer loading and increase the transformer capacity or split the load with an accessory transformer as required.

Step 8—Compressor Crankcase Heater

When equipped with a crankcase heater, furnish power to heater a minimum of 24 hrs before starting unit. To furnish power to heater only, set thermostat to OFF position and close electrical disconnect to outdoor unit.

A crankcase heater is required if the refrigerant tubing is longer than 50 ft. Refer to Residential Split System Long-Line Application Guideline.

Step 9—Install Electrical Accessories, If Any

Refer to the individual instructions packaged with the kit or accessory when installing.

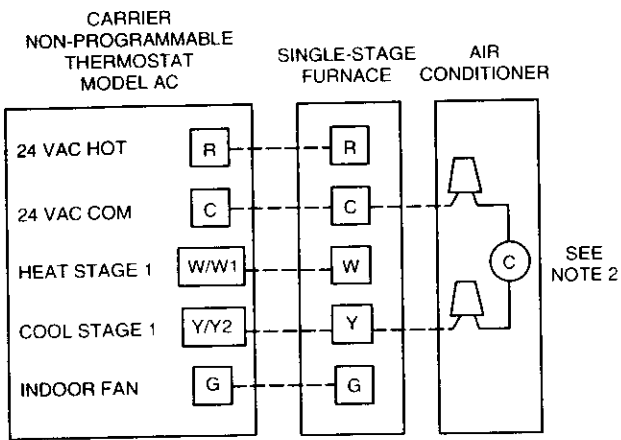

A97467

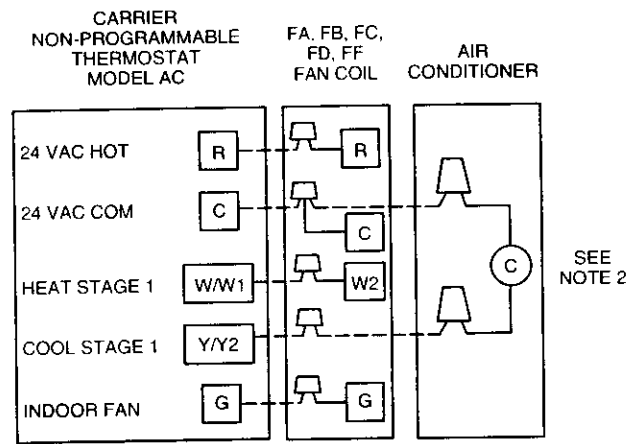

A9468

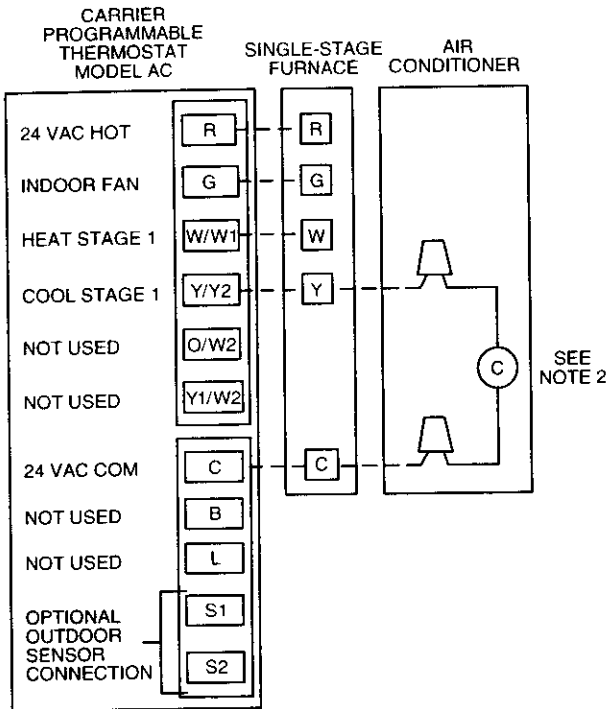

A97469

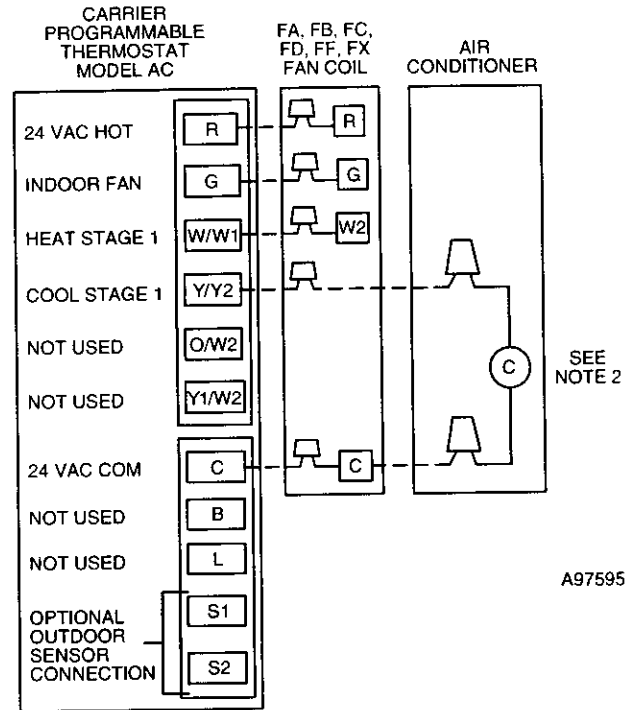

A97595

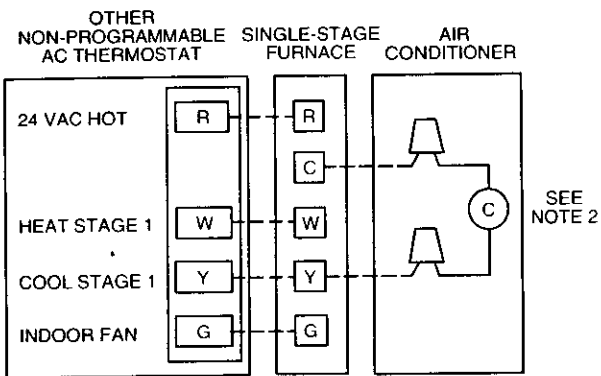

A97367

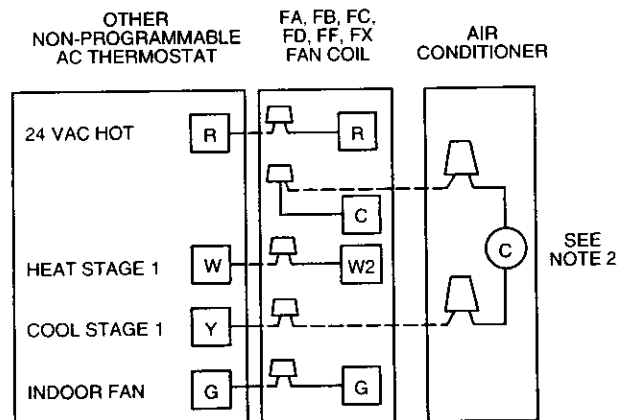

A97593

Fig. 5—24-v Control Circuit Connections

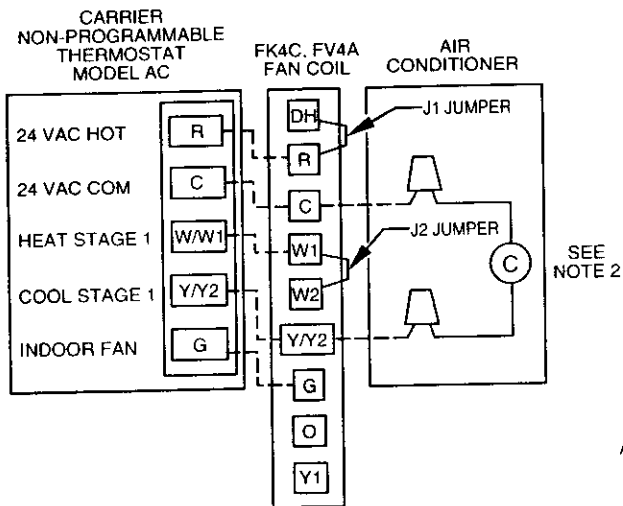

A97596

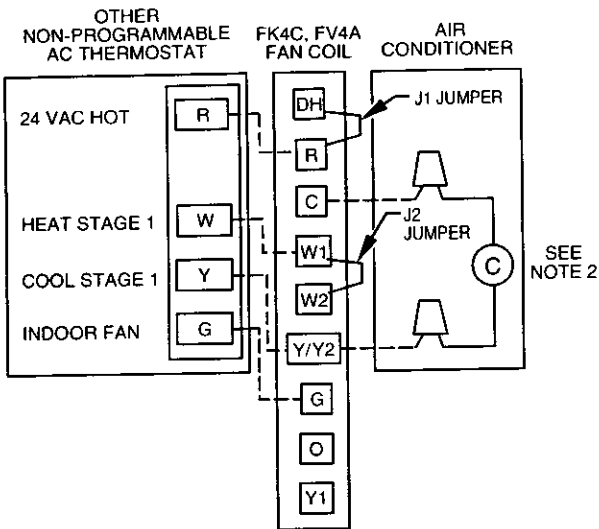

A97592

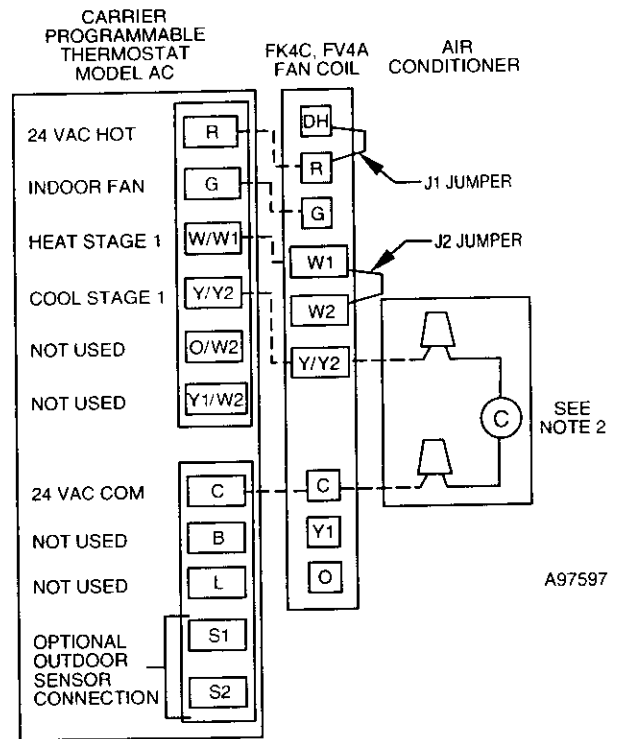

A97597

NOTES:

1. CARRIER THERMOSTAT WIRING DIAGRAMS ARE ONLY ACCURATE FOR MODEL NUMBERS BEGINNING WITH TSTAT
2. WIRING MUST CONFORM TO NEC OR LOCAL CODES.
3. SOME UNITS ARE EQUIPPED WITH PRESSURE SWITCH(ES), TEMPERATURE SWITCH, OR 5-MINUTE COMPRESSOR CYCLE PROTECTION. CONNECT 24-V FIELD WIRING TO FACTORY-PROVIDED STRIPPED LEADS.
4. A LIQUID-LINE SOLENOID VALVE IS REQUIRED ON SOME UNITS.
5. THERMOSTATS ARE FACTORY CONFIGURED WITH 5-MINUTE COMPRESSOR CYCLE PROTECTION AND 4 CYCLES PER HOUR LIMIT. SEE THERMOSTAT INSTALLATION INSTRUCTIONS FOR DETAILS.
6. TO STAGE ELECTRIC RESISTANCE HEAT, CONSULT OUTDOOR THERMOSTAT INSTALLATION INSTRUCTIONS.

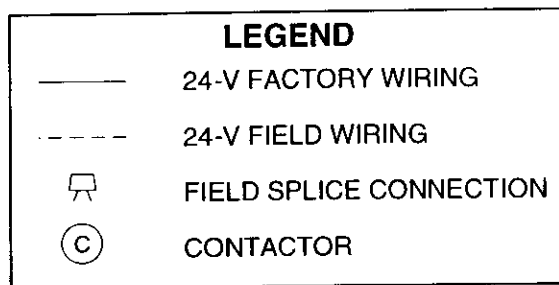

A97368

Fig. 5—Typical 24-v Circuit Connections (Continued)

Step 10—Start-Up and Check Charge

⚠ CAUTION

To prevent compressor damage or personal injury, observe the following:

- Do not overcharge system with refrigerant.
 - Do not operate unit in a vacuum or at negative pressure.
 - Do not disable low-pressure switch
- In scroll compressor applications:
- Dome temperatures may be hot.
 - In 3 phase application, incorrect phasing will cause reverse rotation, resulting in elevated noise levels, equalized pressures and reduced current draw. Correct by reversing power connection L1 and L2 on contactor.

⚠ CAUTION

To prevent personal injury wear safety glasses, protective clothing, and gloves when handling refrigerant and observe the following:

- Back seating service valves are not equipped with Schrader valves. Fully back seat (counter clockwise) valve stem before removing gage port cap.
- Front seating service valves are equipped with Schrader valves.

⚠ CAUTION

Do not vent refrigerant to atmosphere. Recover during system repair or final unit disposal.

Follow these steps to start up the system:

1. Fully back seat (open) liquid and vapor tube service valves.
2. Unit is shipped with valve stem(s) front seated (closed) and caps installed. Replace stem caps after system is opened to refrigerant flow. Replace caps finger-tight and tighten with wrench an additional 1/12 turn.
3. Close electrical disconnects to energize system.
4. Set room thermostat at desired temperature. Be sure set point is below indoor ambient temperature.
5. Set room thermostat at COOL and fan control at ON or AUTO mode, as desired. Operate unit for 15 minutes. Check system refrigerant charge.

SEQUENCE OF OPERATION — Turn on power to indoor and outdoor units. Transformer is energized.

On a call for cooling, the thermostat makes circuits R-Y and R-G. Circuit R-Y energizes contactor, starting outdoor fan motor and compressor circuit. R-G energizes the indoor unit blower relay, starting the indoor blower motor on high speed.

When the thermostat is satisfied, its contacts open, de-energizing contactor and blower relay. Compressor and motors stop.

If indoor unit is equipped with a time-delay relay circuit, the indoor blower will run an additional 90 seconds to increase system efficiency.

Step 11—Check Charge

UNIT CHARGE — Factory charge is shown on unit rating plate. Adjust charge by following procedure shown on charging tables located on unit.

NOTE: If superheat or subcooling charging conditions are not favorable, charge must be weighed in accordance with unit rating plate ± 0.6 oz/ft of 3/8-in. liquid line above or below 15 ft respectively.

EXAMPLE:

25 ft - 15 ft = 10 ft X 0.6 oz/ft = 6 oz of additional charge

COOLING ONLY PROCEDURE — The following procedure is valid when indoor airflow is within $\pm 21\%$ of its rated CFM.

1. Operate unit a minimum of 10 minutes before checking charge.
2. Measure suction pressure by attaching an accurate gage to suction valve service port.
3. Measure suction temperature by attaching an accurate thermistor type or electronic thermometer to suction line at service valve.
4. Measure outdoor air dry-bulb temperature with thermometer.
5. Measure indoor air (entering indoor coil) wet-bulb temperature with a sling psychrometer.
6. Refer to Table 3. Find outdoor temperature and evaporator entering air wet-bulb temperature. At this intersection, note superheat.
7. Refer to Table 4. Find superheat temperature located in item 6 and suction pressure. At this intersection, note suction line temperature.
8. If unit has a higher suction line temperature than charted temperature, add refrigerant until charted temperature is reached.
9. If unit has a lower suction line temperature than charted temperature, reclaim refrigerant until charted temperature is reached.
10. If outdoor air temperature or pressure at suction valve changes, charge to new suction line temperature indicated on chart.

Step 12—Final Checks

IMPORTANT: Before leaving job, be sure to do the following:

1. Securely fasten all panels and covers.
2. Tighten service valve stem caps to 1/12-turn past finger tight.
3. Leave User's Manual with owner. Explain system operation and periodic maintenance requirements outlined in manual.
4. Fill out Dealer Installation Checklist and place in customer file.

CARE AND MAINTENANCE

For continuing high performance and to minimize possible equipment failure, periodic maintenance **must** be performed on this equipment.

Frequency of maintenance may vary depending on geographic areas, such as coastal applications, which may require more frequent maintenance.

Table 3—Superheat Charging

OUTDOOR TEMP (°F)	EVAPORATOR ENTERING AIR TEMPERATURE (°F WB)													
	50	52	54	56	58	60	62	64	66	68	70	72	74	76
55	9	12	14	17	20	23	26	29	32	35	37	40	42	45
60	7	10	12	15	18	21	24	27	30	33	35	38	40	43
65	—	6	10	13	16	19	21	24	27	30	33	36	38	41
70	—	—	7	10	13	16	19	21	24	27	30	33	36	39
75	—	—	—	6	9	12	15	18	21	24	28	31	34	37
80	—	—	—	—	5	8	12	15	18	21	25	28	31	35
85	—	—	—	—	—	—	8	11	15	19	22	26	30	33
90	—	—	—	—	—	—	5	9	13	16	20	24	27	31
95	—	—	—	—	—	—	—	6	10	14	18	22	25	29
100	—	—	—	—	—	—	—	—	8	12	15	20	23	27
105	—	—	—	—	—	—	—	—	5	9	13	17	22	26
110	—	—	—	—	—	—	—	—	—	6	11	15	20	25
115	—	—	—	—	—	—	—	—	—	—	8	14	18	23

—Where a dash appears, do not attempt to charge system under these conditions or refrigerant slugging may occur. Charge must be weighed in. NOTE: Superheat °F is at low-side service port.

Table 4—Required Suction-Line Temperature

SUPERHEAT TEMP (°F)	SUCTION PRESSURE AT SERVICE PORT (PSIG)									
	61.5	64.2	67.1	70.0	73.0	76.0	79.2	82.4	85.7	
0	35	37	39	41	43	45	47	49	51	
2	37	39	41	43	45	47	49	51	53	
4	39	41	43	45	47	49	51	53	55	
6	41	43	45	47	49	51	53	55	57	
8	43	45	47	49	51	53	55	57	59	
10	45	47	49	51	53	55	57	59	61	
12	47	49	51	53	55	57	59	61	63	
14	49	51	53	55	57	59	61	63	65	
16	51	53	55	57	59	61	63	65	67	
18	53	55	57	59	61	63	65	67	69	
20	55	57	59	61	63	65	67	69	71	
22	57	59	61	63	65	67	69	71	73	
24	59	61	63	65	67	69	71	73	75	
26	61	63	65	67	69	71	73	75	77	
28	63	65	67	69	71	73	75	77	79	
30	65	67	69	71	73	75	77	79	81	
32	67	69	71	73	75	77	79	81	83	
34	69	71	73	75	77	79	81	83	85	
36	71	73	75	77	79	81	83	85	87	
38	73	75	77	79	81	83	85	87	89	
40	75	77	79	81	83	85	87	89	91	

Free Manuals Download Website

<http://myh66.com>

<http://usermanuals.us>

<http://www.somanuals.com>

<http://www.4manuals.cc>

<http://www.manual-lib.com>

<http://www.404manual.com>

<http://www.luxmanual.com>

<http://aubethermostatmanual.com>

Golf course search by state

<http://golfingnear.com>

Email search by domain

<http://emailbydomain.com>

Auto manuals search

<http://auto.somanuals.com>

TV manuals search

<http://tv.somanuals.com>